



MICROWAVE OVEN

SERVICE MANUAL

MODEL : MB-4022W/MH-6022W

CAUTION

BEFORE SERVICING THE UNIT, READ THE
SAFETY PRECAUTIONS IN THIS MANUAL.

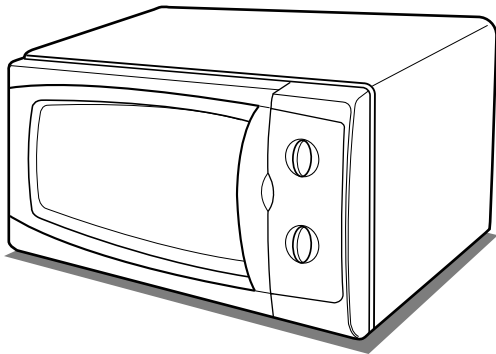

SAFETY PRECAUTIONS

This device is to be serviced only by properly qualified service personnel.

Consult the service manual for proper service procedures to assure continued safety operation and for precautions to be taken to avoid possible exposure to excessive microwave energy.

PRECAUTIONS TO BE OBSERVED BEFORE AND DURING SERVICING TO AVOID POSSIBLE EXPOSURE TO EXCESSIVE MICROWAVE ENERGY

- A) Do not operate or allow the oven to be operated with the door open.
- B) Make the following safety checks on all ovens to be serviced before activating the magnetron or other microwave source, and make repairs as necessary; (1) interlock operation, (2) proper door closing, (3) seal and sealing surfaces (arcing, wear, and other damage), (4) damage to or loosening of hinges and latches, (5) evidence of dropping or abuse.
- C) Before turning on microwave power for any service test or inspection within the microwave generating compartments, check the magnetron, wave guide or transmission line, and cavity for proper alignment, integrity, and connections.
- D) Any defective or misadjusted components in the interlock, monitor, door seal, and microwave generation and transmission systems shall be repaired, replaced, or adjusted by procedures described in this manual before the oven is released to the owner.
- E) A microwave leakage check to verify compliance with the Federal Performance Standard should be performed on each oven prior to release to the owner.

CAUTION MICROWAVE RADIATION

DO NOT BECOME EXPOSED TO RADIATION FROM THE MICROWAVE GENERATOR OR OTHER PARTS CONDUCTING MICROWAVE ENERGY.

CONTENTS

(Page)

SAFETY PRECAUTIONS	Inside front cover
SPECIFICATIONS	1-1
CAUTIONS	2-1
INSTALLATIONS	3-1
OPERATING INSTRUCTIONS	4-1
FEATURES.....	4-1
CONTROL PANEL.....	4-1
OPERATING SEQUENCE.....	4-2
SCHEMATIC DIAGRAM	4-3
CIRCUIT DESCRIPTION	4-4
SERVICE INFORMATION	5-1
TOOLS AND MEASURING INSTRUMENTS	5-1
MICROWAVE LEAKAGE TEST	5-1
MEASUREMENT OF MICROWAVE POWER OUTPUT	5-3
DISASSEMBLY AND ADJUSTMENT.....	5-3
INTERLOCK CONTINUITY TEST.....	5-7
COMPONENT TEST PROCEDURE	5-8
TROUBLE SHOOTING	5-12
EXPLODED VIEW	6-1
REPLACEMENT PARTS LIST	7-1

SPECIFICATIONS

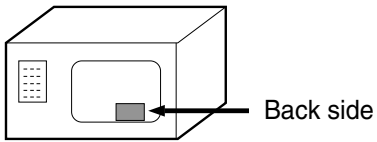
ITEM	DESCRIPTION
MODEL	MB-4022W, MH-6022W
Power Requirement	230 Volts AC 50 Hz Single phase, 3 wire grounded Microwave 1,200W Grill 1,100W Combi 2,250W
Power Output	800 Watts full microwave power (IEC 60705)
Microwave Frequency	2,450 MHz
Magnetron	2M214 - 39F, 2M218J, 2M254J
Timer	60 Min.
Outside Dimensions	485 (W) x 280 (H) x 350 (D) mm
Cavity Dimensions	312 (W) x 198 (H) x 316 (D) mm
Net Weight	13.5 kg (approx.)
Shipping weight	15.0 kg (approx.)
Control Complement	Microwave Power for Variable Cooking Power level Max 600W 360W ☼☼ Defrost 90W Grill Combi - 1, 2, 3
Name Plate Location	
Accessories	Owner's manual Glass tray Rotating ring Grill rack
This microwave oven is designed for household use only. It is not recommended for commercial purposes.	

CAUTIONS

Unlike other appliances, the microwave oven is high-voltage and high-current equipment. Though it is free from danger in ordinary use, extreme care should be taken during repair.

- DO NOT operate on a 2-wire extension cord during repair and use.
- NEVER TOUCH any oven components or wiring during operation.
- BEFORE TOUCHING any parts of the oven, always remove the power plug from the outlet.
- For about 30 seconds after the oven stops, an electric charge remains in the high voltage capacitor. When replacing or checking, you must discharge the high voltage capacitor by shorting across the two terminals with an insulated screwdriver.

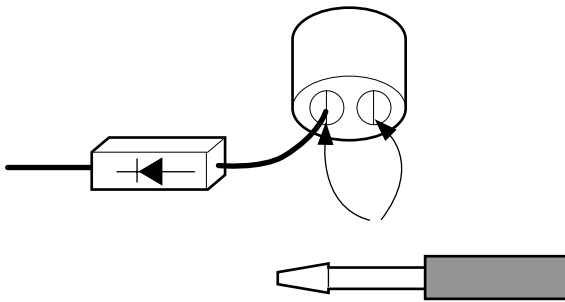

- Remove your watches whenever working close to or replacing the Magnetron.
- NEVER operate the oven with no load.
- NEVER injure the door seal and front plate of the oven cavity.
- NEVER put iron tools on the magnetron.
- NEVER put anything into the latch hole and the interlock switches area.

MICROWAVE RADIATION

Personnel should not be exposed to the microwave energy which may radiate from the magnetron or other microwave generating device if it is improperly used or connection. All input and output microwave connections, waveguide, flange and gasket must be secure never operate the device without a microwave energy absorbing load attached. Never look into an open waveguide or antenna while the device is energized.

- Proper operation of the microwave oven requires that the magnetron be assembled to the waveguide and cavity. Never operate the magnetron unless it is properly installed.
- **Be sure that the magnetron gasket is properly installed around the dome of the tube whenever installing the magnetron.**

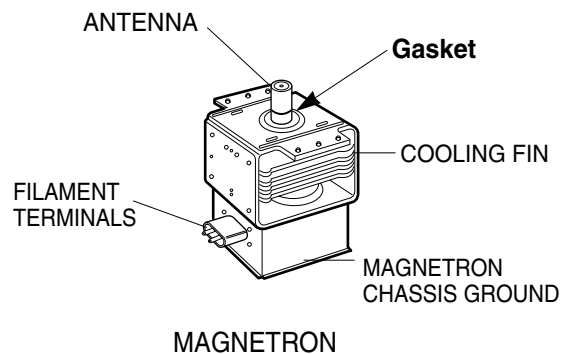

THE OVEN IS TO BE SERVICED ONLY BY PROPERLY QUALIFIED SERVICE PERSONNEL.

INSTALLATIONS

BEFORE YOU BEGIN, READ THE FOLLOWING INSTRUCTIONS COMPLETELY AND CAREFULLY.

INSTALLING

1. Empty the microwave oven and clean inside it with a soft, damp cloth. Check for damage such as misaligned door, damage around the door or dents inside the cavity or on the exterior.
2. Put the oven on a counter, table, or shelf that is strong enough to hold the oven and the food and utensils you put in it. (The control panel side of the oven is the heavy side. Use care when handling.)
3. Do not block the vent and the air intake openings. Blocking vent or air intake openings can cause damage to the oven and poor cooking results. Make sure the microwave oven legs are in place to ensure proper air flow.
4. The oven should not be installed in any area where heat and steam are generated, because they may damage the electronic or mechanical parts of the unit. Do not install the oven next to a conventional surface unit or above a conventional wall oven.
5. Use microwave oven in an ambient temperature less than 104°F(40°C).
6. Place the microwave oven on a sturdy and flat surface at least 10 cm(4 inches) from the wall.
7. Place the microwave oven as far away as possible from TV, RADIO, COMPUTER, etc., to prevent interference.
8. Do not touch the front glass during or after cooking of the Grill and Combination mode. This glass is very hot during heater operating.
9. Do not operate the oven at microwave and combination mode with Grill rack placed in the cavity when the oven is empty.

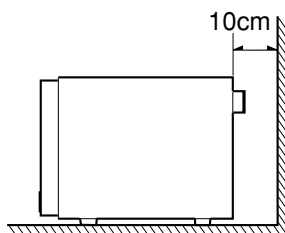

EARTHING INSTRUCTIONS

This microwave oven is designed to be used in a fully earthed condition. It is imperative, therefore, to make sure it is properly earthed before servicing

WARNING- THIS APPLIANCE MUST BE EARTHED

IMPORTANT

The wires in this mains lead are colored in accordance with the following code:

Green-and-yellow:	Earth
Blue:	Neutral
Brown:	Live

As the colors of the wires in the mains lead of this appliance may not correspond with the colored markings identifying the terminals in your plug, proceed as follows.

The wire which is colored **green-and-yellow** must be connected to the terminal in the plug which is marked with the letter **E** or by the **earth symbol** (\perp) or colored **green** or **green-and-yellow**.

The wire which is colored **blue** must be connected to the terminal in the plug which is marked with the letter **N** or colored **black**.

The wire which is colored **brown** must be connected to the terminal in the plug which is marked with the letter **L** or colored **red**.

OPERATING INSTRUCTIONS

FEATURES

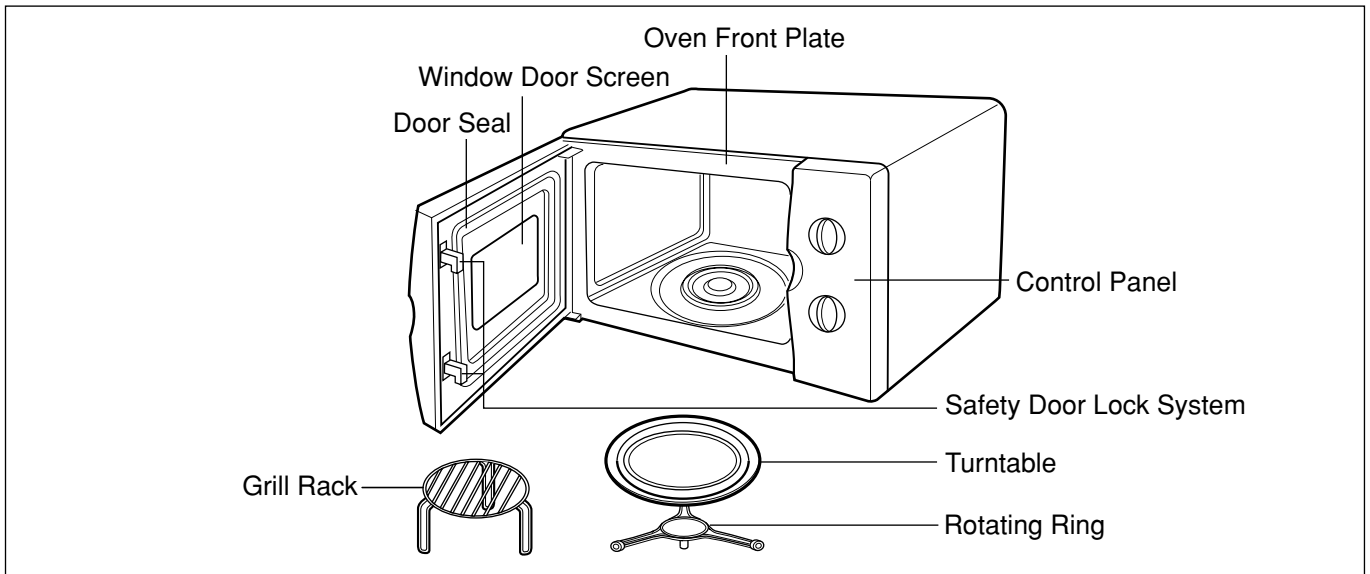

CONTROL PANEL

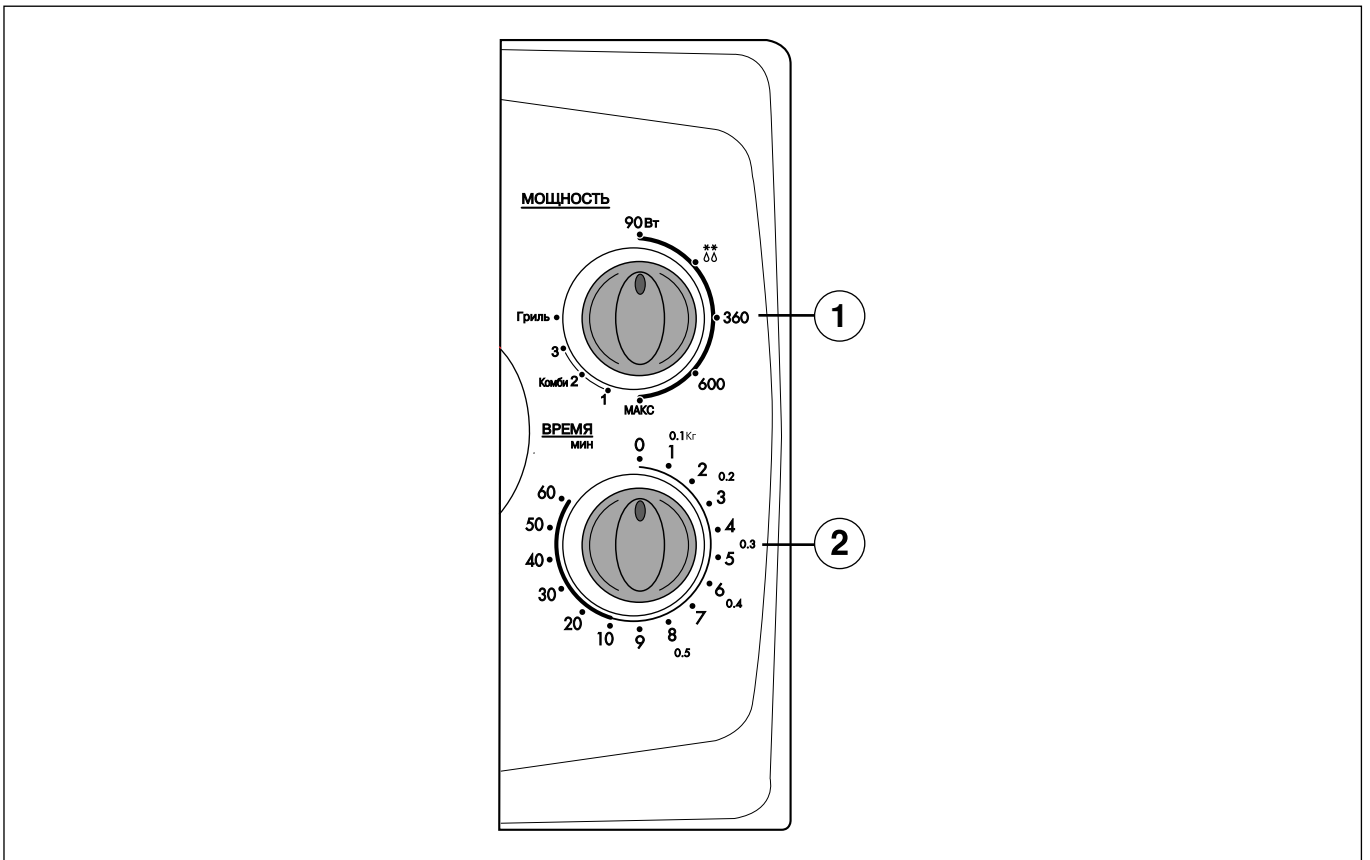

1. POWER CONTROL KNOB: Used in selected the desired power level for cooking.
2. TIMER KNOB: Used to set the cooking time.

OPERATING SEQUENCE

MICROWAVE COOKING

1. Open the oven door, place the food on the turntable in the oven, and close the oven door.
2. Set the function selector to the microwave.

POSITIONS
MAX
600W
360W
 DEFROST
90W

3. Set the microwave power selector to the desired power level. There are five power levels from WARM to HIGH. The power selector can be set to any one of these positions.

NOTE:

- Each number represents minutes. To ensure accurate timing, it is advisable to turn the timer knob slightly passed the desired cooking time and then back to the proposed setting.
- Press the door opener to check the cooking condition during oven operation. Opening the door during oven operation automatically turns off the oven and stops the timer. If cooking is to continue, close the door. Cooking will be resumed until the full cooking time has elapsed.

GRILL COOKING

1. Open the oven door, place the food on the rack in the oven, and close the oven door.
2. Set the  function.
3. Set the timer to the desired cooking time. The turntable begins to rotate, cooking starts, and the lamp is turned on. At the end of the cooking time you will hear a ring sound and the lamp is turned off.

COMBI COOKING

1. Open the oven door, place the food on the rack in the oven, and close the oven door.
2. Set the  (1, 2, 3) function.
3. Set the timer to the desired cooking time. The turntable begins to rotate, cooking starts, and the lamp is turned on. At the end of the cooking time you will hear a ring sound and the lamp is turned off.

- Refer to the note under MICROWAVE COOKING if you want to check the cooking condition.
- Don't touch the front screen of the door during grill & combi operation, because the temperature of the glass may rise to up to 100°C. Prevent children from touching the front screen!
- When the grill & combi is operated for the first time after purchasing the oven, slight smoke and smell may occur. These will soon disappear.

SCHEMATIC DIAGRAM

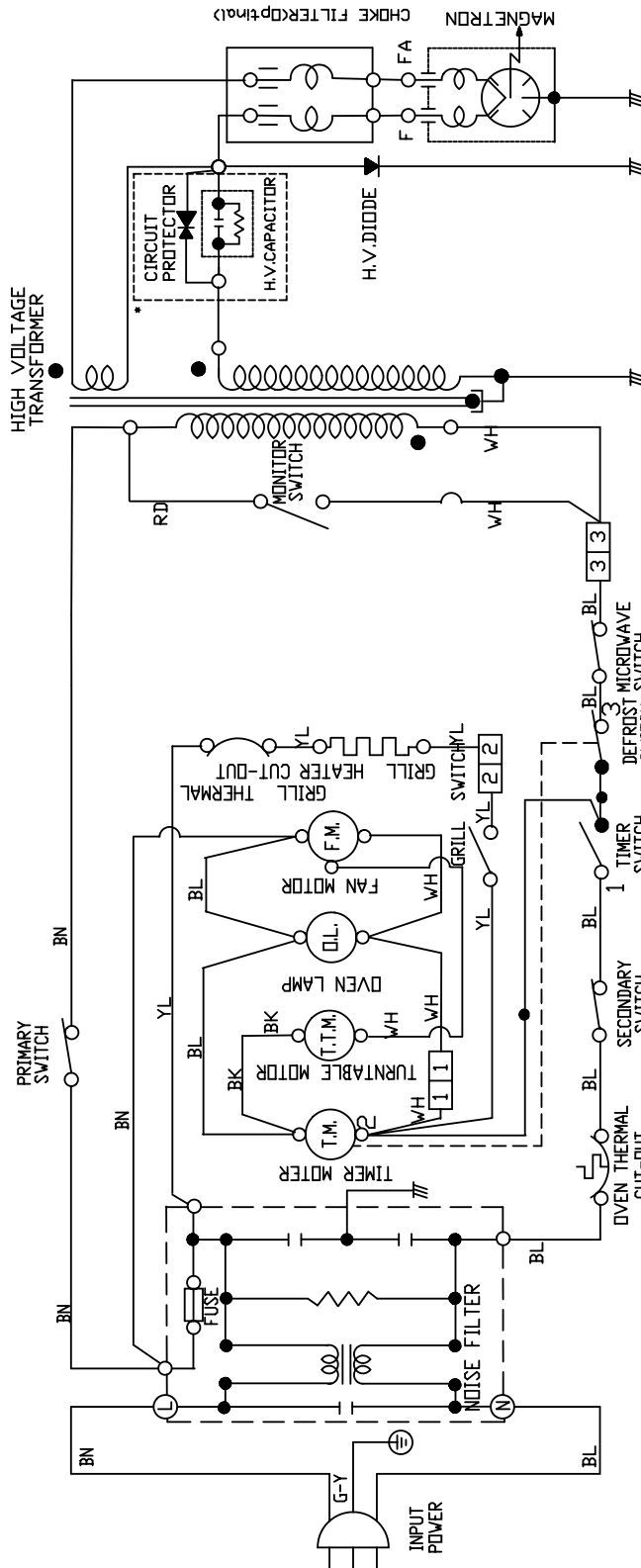

* NOTE 1. DOOR IS CLOSED.
 2. COOK OFF.
 3. CIRCUIT BE SUBJECT TO CHANGE WITHOUT NOTICE.

ACHTUNG Hochspannungskondensator vor allen Servicearbeiten gegen Masse entladen.!!
 AVANT INTERVENTION TECHNIQUE, DECONNECTER ET DECHARGER LA CAPACITE DE HAUT VOLTAGE.
 BEFORE SERVICING Discharge the high voltage Capacitor by shorting the negative high voltage Terminal of it to chassis ground.

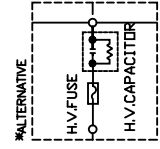

SYMBOL	COLOR	SYMBOL	COLOR
G-Y	GREEN-YELLOW	WH	WHITE
BN	BROWN	BL	BLUE
RD	RED	YL	YELLOW
BK	BLACK		

CIRCUIT DESCRIPTION

- As the door is closed, the contact of MONITOR SWITCH opens. This switch creates the short circuit to blow fuse during operation under abnormal condition. (ie, should the contacts of primary and secondary switch fail to open the circuit)
- The latches are secured by latch board. The oven light turns on while the oven is in operation.

WHEN MICROWAVE POWER LEVEL AND COOKING TIME SET

- The contacts of the timer switch changes to ON position when the timer knob is rotated. (While power control knob is set at "Full Power")
- The contacts of primary and secondary switch close the circuit.
- Input Volts AC. is applied to the high voltage transformer through power control switch as shown by the solid line.

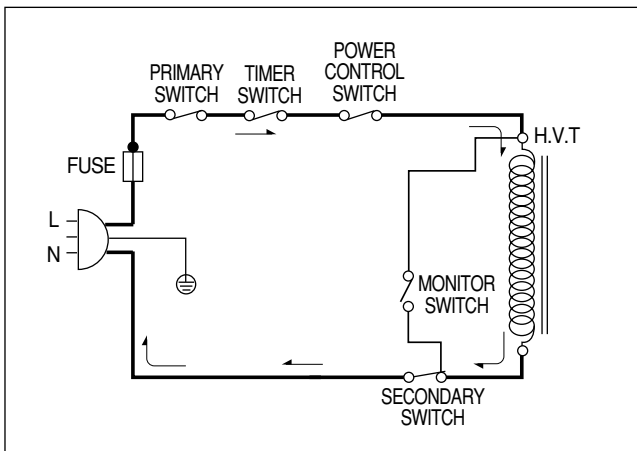

- Turntable rotates.
- The fan motor rotates and cools the magnetron by blowing the air (coming from the intake holes on the baseplate) over the magnetron.
- The air is also directed into the oven to exhaust the vapor in the oven through the upper plate.
- Timer starts rotating.
- 3.2 volts AC is generated from the filament winding of the high voltage transformer. This 3.2 volts is applied to the magnetron to heat the magnetron filament through two noise preventing choke coils. A high voltage of approximately 2100 volts AC is generated in the secondary of the high voltage transformer which is increased by the action of the diode and charging of the high voltage capacitor. The negative DC voltage is then applied to the filament of the magnetron.

WHEN THE DOOR IS OPENED DURING COOKING

- Both primary switch and secondary switch open to cut off the primary winding voltage to the high voltage transformer to stop microwave oscillation.
- Timer, turntable and fan motor stop.
- As the door is opened, if the contact of primary switch fail to open, the fuse opens due to the large current surge caused by the monitor switch activation which in turn stops magnetron, oscillation.

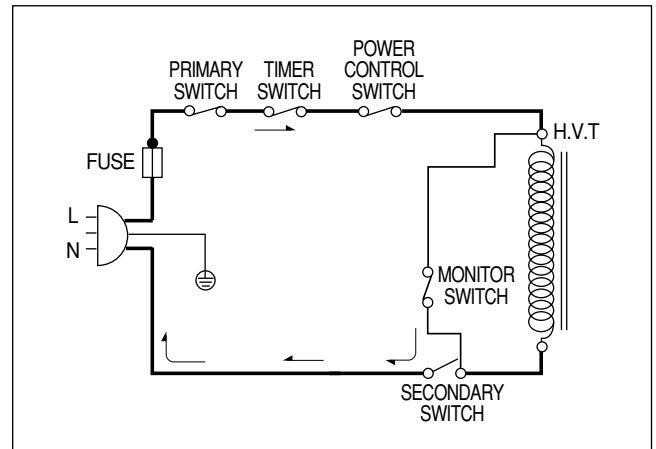

WHEN THE GRILL COOKING FUNCTION SELECTED

- The contacts of the timer switch change to ON position.
- The contacts of the grill select switch close the circuit.
- Input volts AC is applied to the grill heater through thermostat-grill as shown by the solid line.
- The fan motor and turntable rotates.

