

Haier SERVICE MANUAL

Refrigerator

MODEL: HTR5720ENMG



WARNING

This service information is designed for experienced repair technicians only and is not designed for use by the general public. It does not contain warnings and cautions to advise non-technical individuals of potential dangers in attempting to service a product. Product powered by electricity should be serviced or repaired only by experienced professional technicians. Any attempt to service or repair the product or products dealt with in this service information by anyone else could result in serious injury or death.

©2019(HAIER ELECTRICAL APPLIANCES COR. LTD)

All right reserved. Unauthorized copying and distribution is a violation of law.

Haier Group

Contents

Chapter 1 General Information	2
1-1. General Guidelines	2
1-2. Insurance test	2
Chapter 2 Product Feature	3
2-1. Specifications	3
2-2. External views	4
2-3 Space requirement	5
2-4. Main features	6
2-5. Explanation of The Models	7
Chapter 3 Disassembly and Installation	8
3-1 Disassembly of the assembly	8
3-2 Door reversibility	10
Chapter 4 System flow principle	13
4-1 Refrigerating cycle plan	13
4-2 Refrigerating cycle perspective	13
Chapter 5 Circuit diagram.....	14
5-1. Brief principle diagram	14
5-2. Main control Chart	15
5-3 PCB pins no break off	19
Chapter 6 Main Function Operating principle	19
6-1 Defrost system	19
6-2 REF Lamp	20
Chapter 7 Control and display system	20
7-1 Control and display panel	20
7-2 Function introduction (See User Manual)	21
Chapter 8 Quick check and Self-test model	26
8-1 Fault Codes and Query Method	26
8-2 Fault content description	26
8-3 Sensor layout plan	27
8-4 Test mode	28
8-5 Demo mode	28
Chapter 9 Electrical Parts specifications	29
Chapter 10 Trouble shooting	30
10-1. Typical faults and solutions	30
10-2. Answers to frequently asked questions	34

Chapter 1 General Information

1-1. General Guidelines

When servicing, observe the original lead dress. If a short circuit is found, replace all parts which have been overheated or damaged by the short circuit. After servicing, see to it that all the protective devices such as insulation barriers, insulation papers shields are properly installed. After servicing, make the following leakage current checks to prevent the customer from being exposed to shock hazards.

- 1) Leakage Current Cold Check
- 2) Leakage Current Hot Check
- 3) Prevention of Electro Static Discharge (ESD) to Electrostatic Sensitive

1-2. Insurance test

1. Check if there is any leak of current.
2. Cut out the power supply before the repair to avoid an electrical shock hazard.
3. In the case of a live-line test, insulating gloves should be worn to avoid potential electrical shock.
4. Confirm the rated current, voltage and capacity before testing with any kinds of instruments.
5. Watch if the upper door is open when you check something at a lower position.
6. Take out every part in the cabinet before moving the machine, especially things like panels (e.g. glass shelf).
7. Please wear intact cotton gloves when repair any parts of the evaporator, so that scratches by the sharp fins can be avoided.
8. If there is a breakdown with the refrigeration system, please surrender the machine to the service center, else the leaked refrigerant may pollute the atmosphere.
9. The refrigerator use AC of 220V with a frequency of 50Hz.
10. A big fluctuation of voltage (exceed the range 187~242V) may cause a start failure of the refrigerator, a burn-out of the control panel and compressor, or an abnormal sound from the compressor in operation. In this condition an automatic voltage regulator over 60W should be added.
11. Take care not to damage the supply line. Don't yank at the line; pull the plug out gently from the receptacle. Don't press the line under the cabinet or step on it. Take care not to roll on or damage the supply line when moves the machine from the wall.
12. In the case of leakage of inflammable gases like carbon monoxide, open the door and windows. Don't pull out or insert the plugs of the appliance.
13. Don't touch the refrigeration surface of the freezing compartment when the refrigerator is in operation, especially when your hand is wet, else you may be glued to the surface.
14. Pull out the plug of power supply during clearance or power outage. Wait at least five minutes to resume the power supply in order to prevent damage to the compressor caused by continuous restart.

Chapter 2 Product Feature

2-1. Specifications

Picture		
Model		HTR5720ENMG
Basic features		
Energy efficiency class	/	E
Climate class	/	SN.N.ST.T
Freezer compartment star rating	/	****
Total capacity	L	483
capacity refrigerator compartment	L	283
capacity freezer compartment (total)	L	140
Chill compartment	L	60
Freezing capacity / 24 hours	kg/24h	10
Energy consumption / year	kWh/year	301
Energy consumption (EN153) per 24 h	kWh/24h	0.825
Max noise level	dB(A)	37
Max storage time by power failure Freezer	h	12
Kind of coolant and weight (R134a/R600a)	/	R600a (62g)
Approvals (VDE / TÜV / IMQ / NF / ÖVE / DEMKO etc.)		TÜV
Certifications (CE / ISO 9001/2 / LGA)		CE
Key features		
Cooling system: (K = Compressor / A = Absorbtion)	/	K
Number of compressor(s)	n°	1
Defrosting Fridge / Freezer (M=manual A=automatic)	/	A/A
Control system (E = Electronic / M = Mechanical)	/	E
NO FROST (Fridge/Freezer)	/	Y
Ventilated (Fridge only)	/	Y
Antibacteria system		N
Basics datas		
Unit dimensions with-out handle (H/W/D)	mm	2006/700/676
Depth with open door	mm	1323
Net weight	kg	109
Voltage / frequency		220-240 V~/ 50Hz
Input power / mains fuse (intensity)	W /A	120/16

2-2. External views

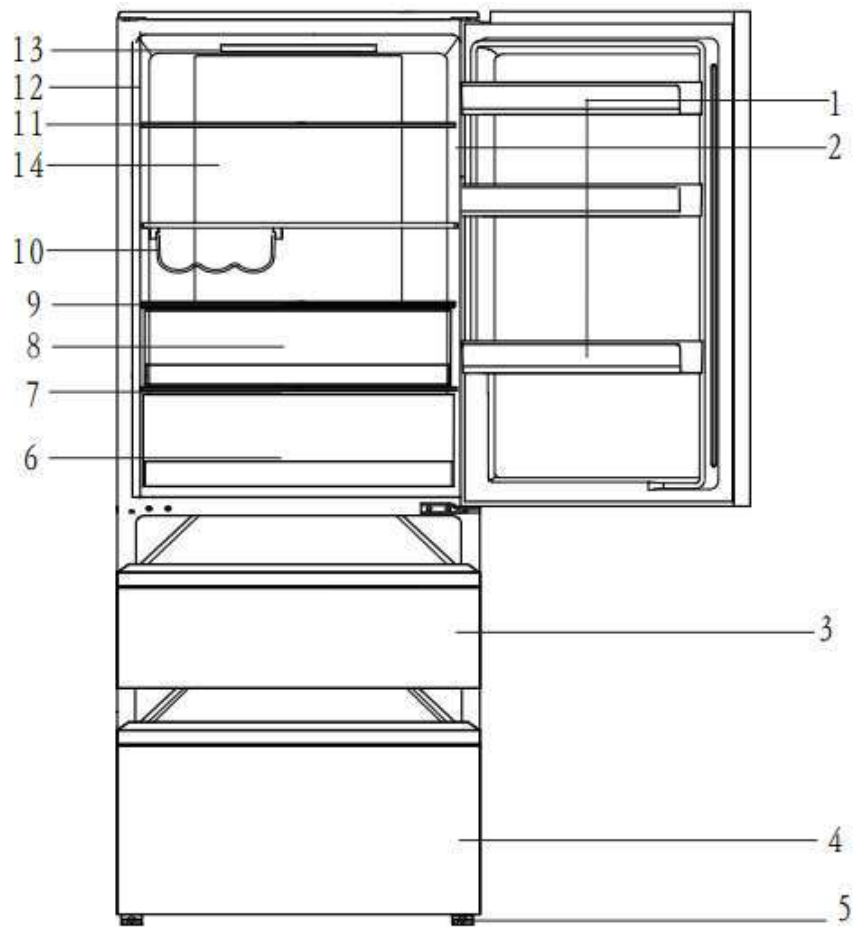

- | | |
|---------------------------------------|-------------------------------|
| 1 Door rack | 9 Humidity drawer glass cover |
| 2 OK-temperature indicator (optional) | 10 Bottle rack |
| 3 Upper freezer storage drawer | 11 Glass shelf |
| 4 Lower freezer storage drawer | 12 Rating plate |
| 5 Adjustable feet | 13 LED lamp |
| 6 MyZone drawer | 14 REF air duck |
| 7 My Zone drawer glass cover | |
| 8 Humidity box | |

2-3 Space requirement

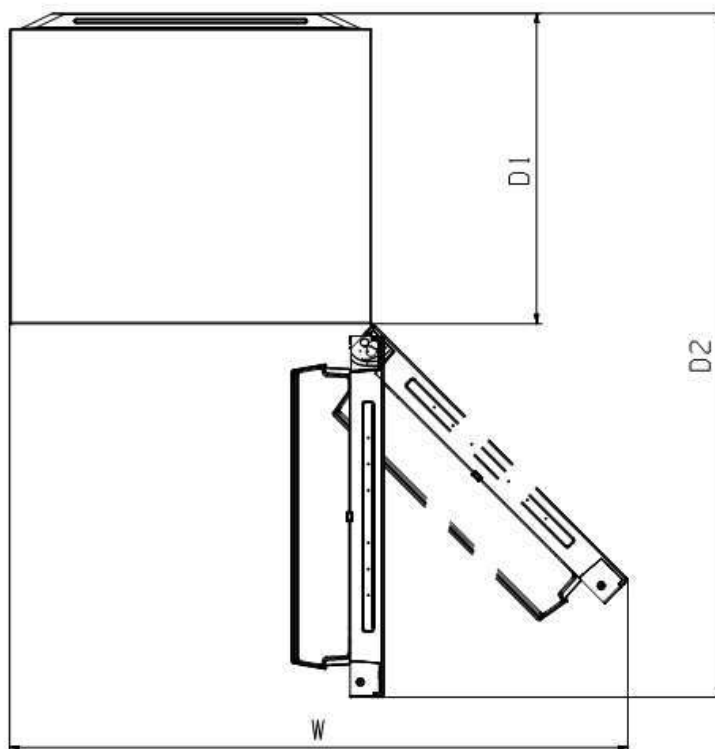

Model	Appliance width in mm		Appliance dept in mm	
	W		D1	D2
HTR5720ENMG	1198.5		600	1140

2-4. Main features

1. Fully closed freezing system and drawer storage can avoid food tainting, keep cold and are energy-saving. As warm air can't easily enter into the storage area when opening the door.
2. Cool wind but no frost: adopting fully air cooled refrigeration system, deep cooling and quick freezing.
3. Holiday function: when you are out for holiday, refrigerator will run at the low energy consumption to make sure there's no odor in the refrigerating chamber and guarantee soft freezing and the normal storage of frozen food.
4. LED display: adopting dynamic LED to display the operational situation of refrigerator.
5. LED light guide plate illumination: adopting the technique of light guide plate illumination, the light is soft, even, bright and no illumination dead angle.
6. Adjusting shelf height: The shelf can be relocated to accommodate food size or height.
7. Double-layer drawer freezer door: the freezer compartment is equipped with the straight-opening fully with drawable double-layer drawer door with which it is easier to access food.

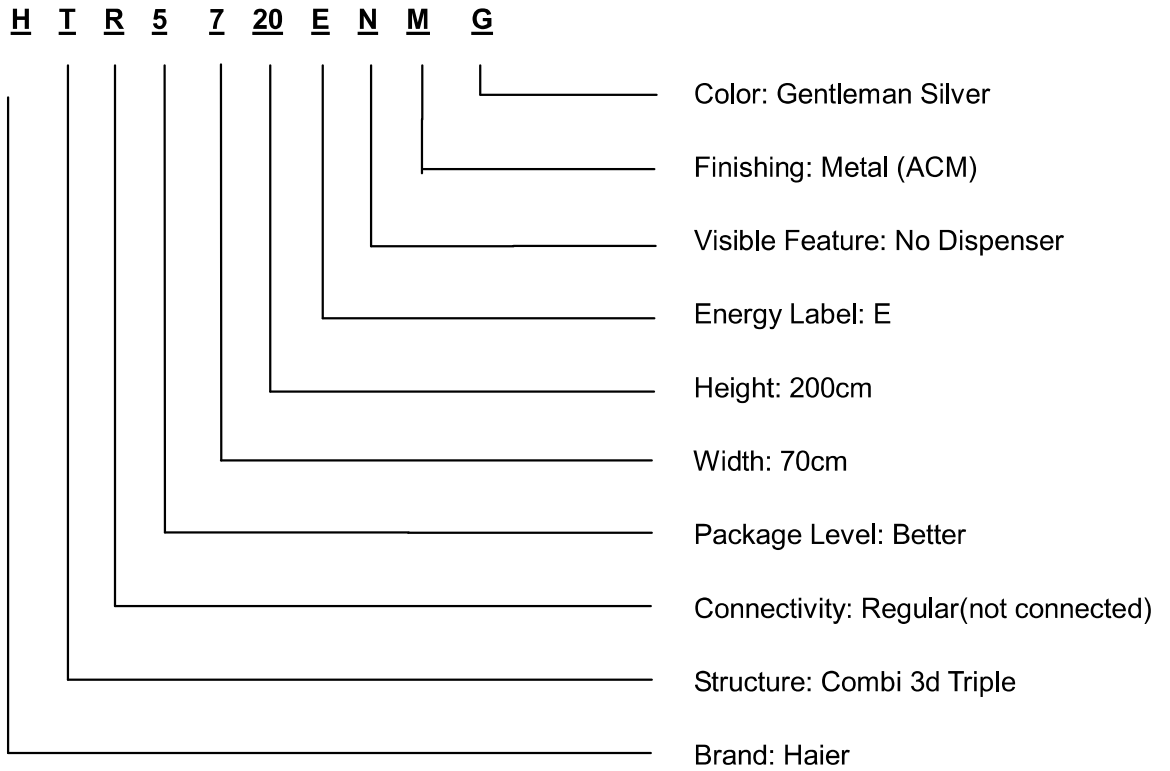

2-5. Explanation of The Models





Chapter 3 Disassembly and Installation



3-1 Disassembly of the assembly

3-1-1 Disassembly of refrigerator duct



	<p>1. Use screwdriver to unscrew two screws on the refrigerator air duct.</p>
	<p>2. Pull the refrigerator air duct out gently, and disconnect the terminal connecting to refrigerator air duct so as to take refrigerator air duct off.</p>

3-1-2 Uninstallation of fan for freezing air duct



	<p>1. Remove the drawer and door from the refrigerator.</p>
	<p>2. Unscrew the screw using cross screwdriver.</p>

	<p>3. Level open the back lid for air duct using slotted screwdriver.</p>
	<p>4. Unplug the wires winding on the clip.</p>

3-1-3 Uninstallation of defrosting heater

	<p>1. Unplug the wires for defrosting heater, slightly separate the two holders from the heater (circled in the picture on the left), move out the defrosting heater from the right holder.</p>
	<p>2. Move out the defrosting heater from the left holder.</p>

3-1-4 Uninstallation of displayer from door

	<p>1. Suck and dismount the display panel with sucker.</p>
	<p>2. Take the terminal off carefully.</p>

3-2 Door reversibility

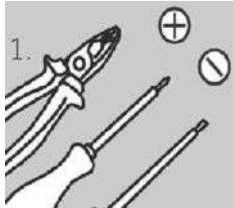
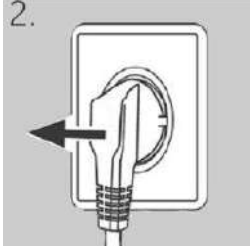
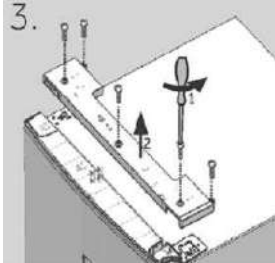
	<p>1. Provide necessary tool.</p>
	<p>2. Unplug the appliance.</p>
	<p>3. Remove the screws which fix the front panel(1) and remove the panel (2). Remove the small cover of the front panel from left to right side.</p>

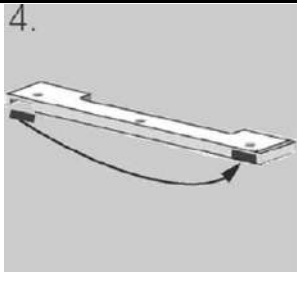
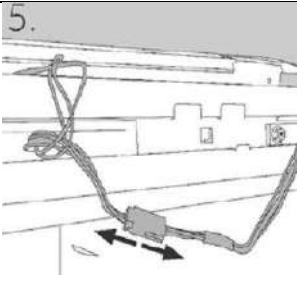
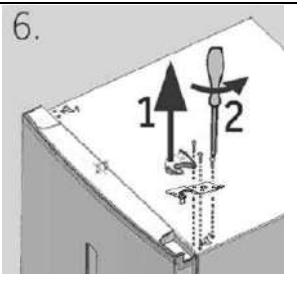
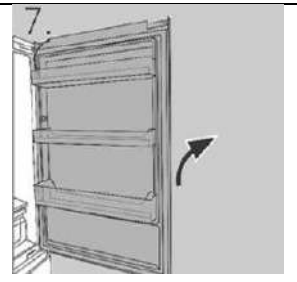
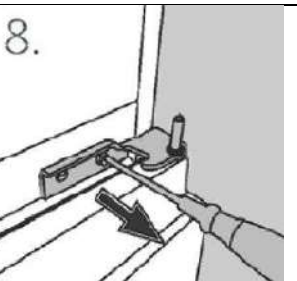
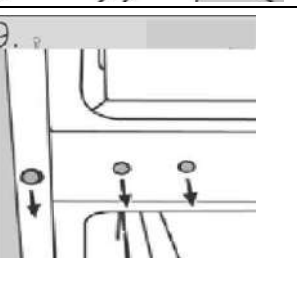
 <p>4.</p>	<p>4. Unplug the connection cable.</p>
 <p>5.</p>	<p>5. Remove the upper hinge cover (1) and unscrew the upper hinge (three screws) on right side (2).</p>
 <p>6.</p>	<p>6. Lift the loose refrigerator door carefully off the lower hinge.</p>
 <p>7.</p>	<p>7. Turn the door upside down. unscrew the cover (1) and the door stop (2) with fixing part (3).</p>
 <p>8.</p>	<p>8. Remove the lower hinge of the upper door.</p>
 <p>9.</p>	<p>9. Change the positions of the blanking plugs and the screw on the side.</p>

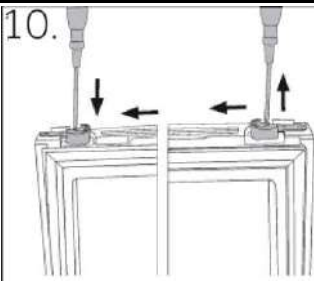
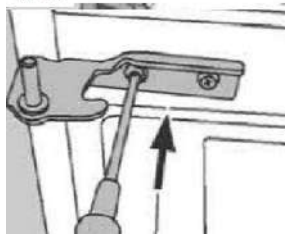
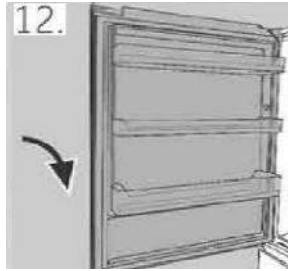
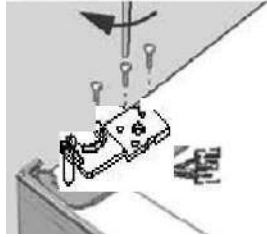
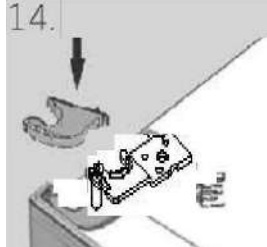
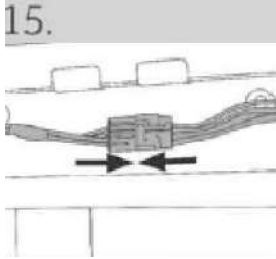
<p>10.</p> 	<p>10. Change the door stop from the current position to opposite side.</p>
<p>11.</p> 	<p>11. Take out the new lower hinge of upper door from the accessory bag and screw it to the left side of the appliance.</p>
<p>12.</p> 	<p>12. Lift the upper door carefully on to the lower hinge so that the pivot fits into the hinge barrel.</p>
<p>13.</p> 	<p>13. Take out the upper hinge from the accessory bag. Put the connection cable through the upper hinge and fix the upper hinge with the three screws on left side of appliance.</p>
<p>14.</p> 	<p>14. Put the hinge cover over (delivered in the accessory bag) the hinge.</p>
<p>15.</p> 	<p>15. Plug in the connection cable and fit it into the opening.</p>

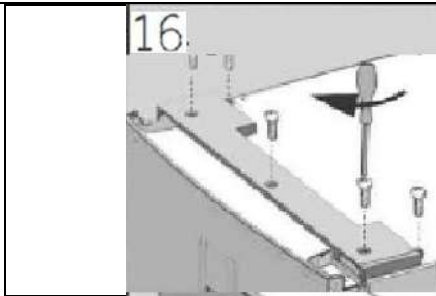

16. Replace front panel and fix it with the five screws. After the change of the door check that the door seals are located properly on the housing and all screws are tightened well.

Chapter 4 System flow principle

4-1 Refrigerating cycle plan

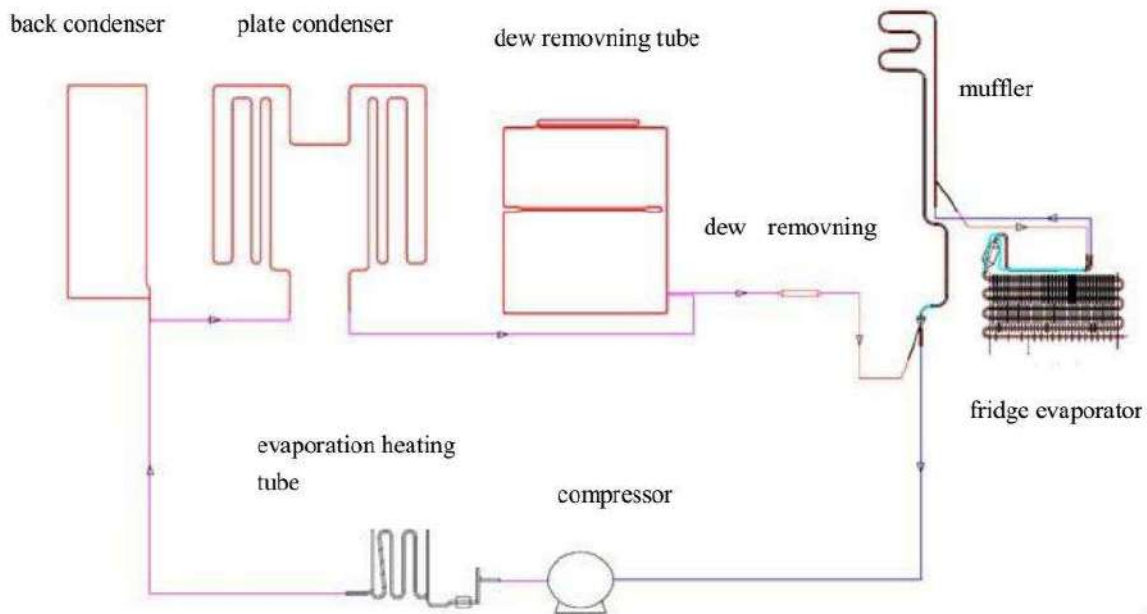

4-2 Refrigerating cycle perspective

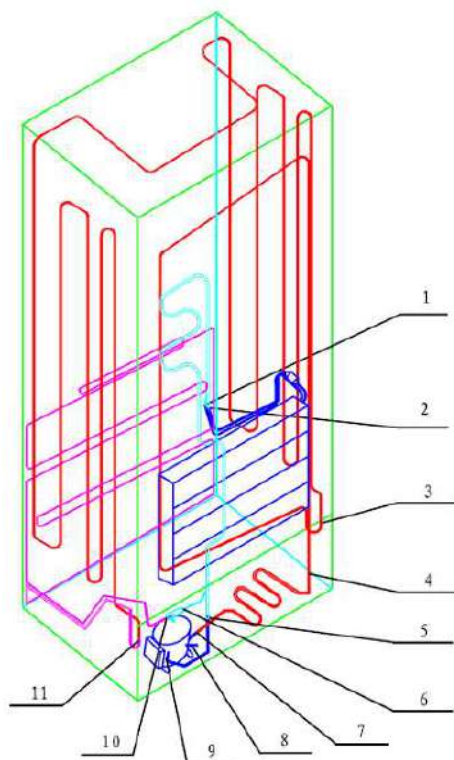

1. capillary and fridge evaporator
2. fridge evaporator and muffler
3. back condenser and plate condenser
4. evaporation heating tube and back condenser
5. muffler and connector tube
6. capillary and dry filter
7. evaporation heating tube and compressor
8. liquid injection tube and compressor
9. connector tube and compressor
10. dew removing tube and drier filter
11. dew removing tube and plate condenser

Chapter 5 Circuit diagram

5-1. Brief principle diagram

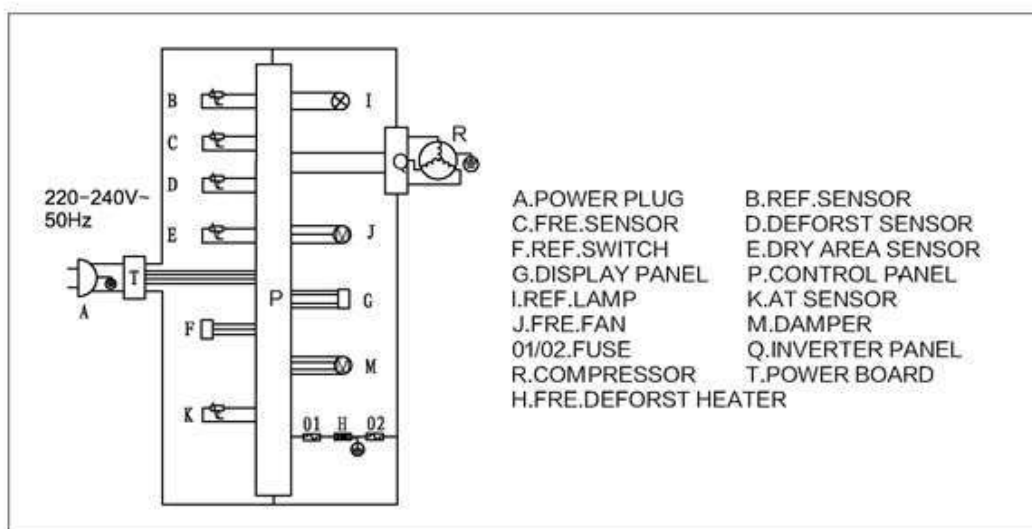

5-2. Main control Chart

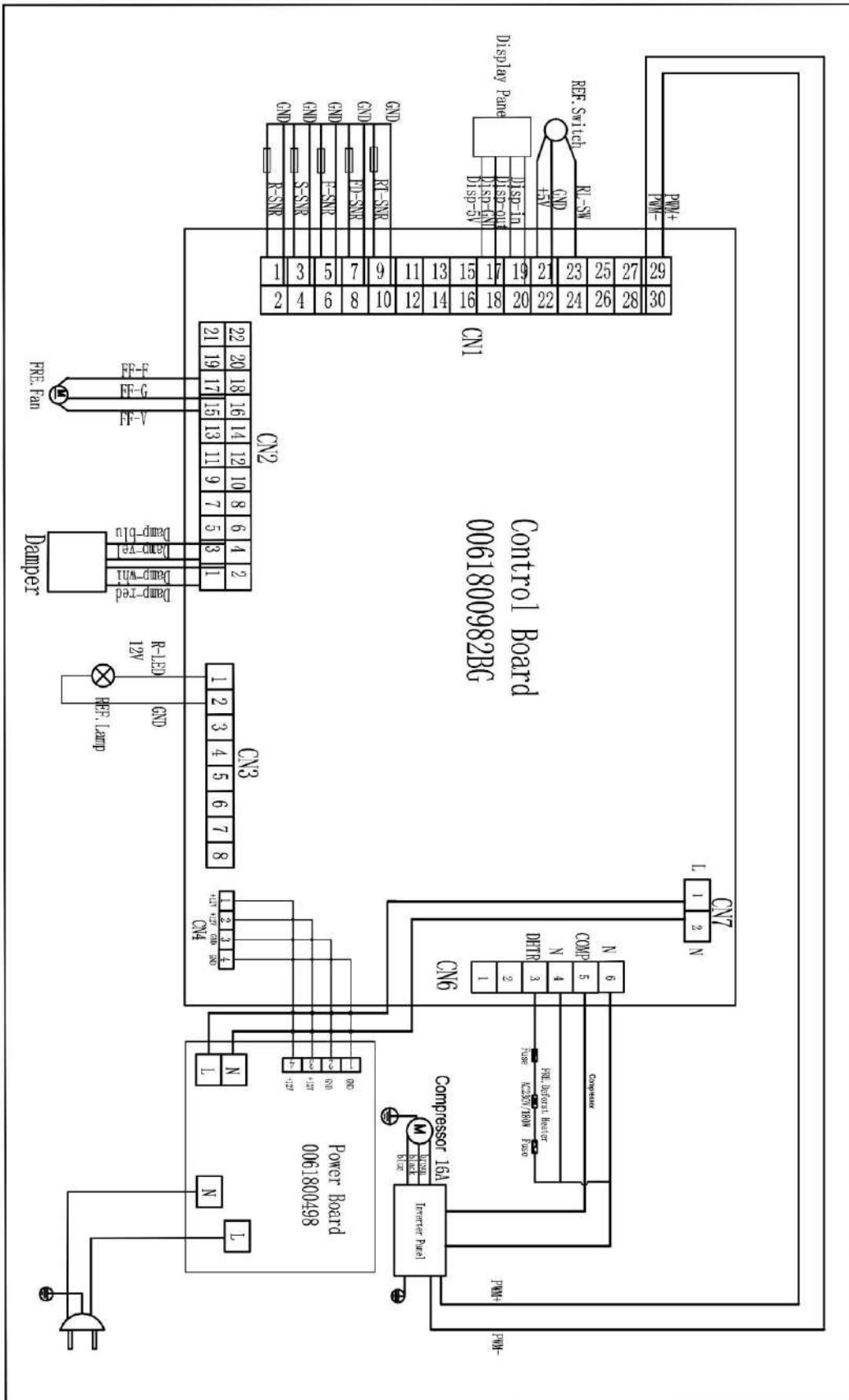

SERVICE MANUAL

Connectors location on PCB

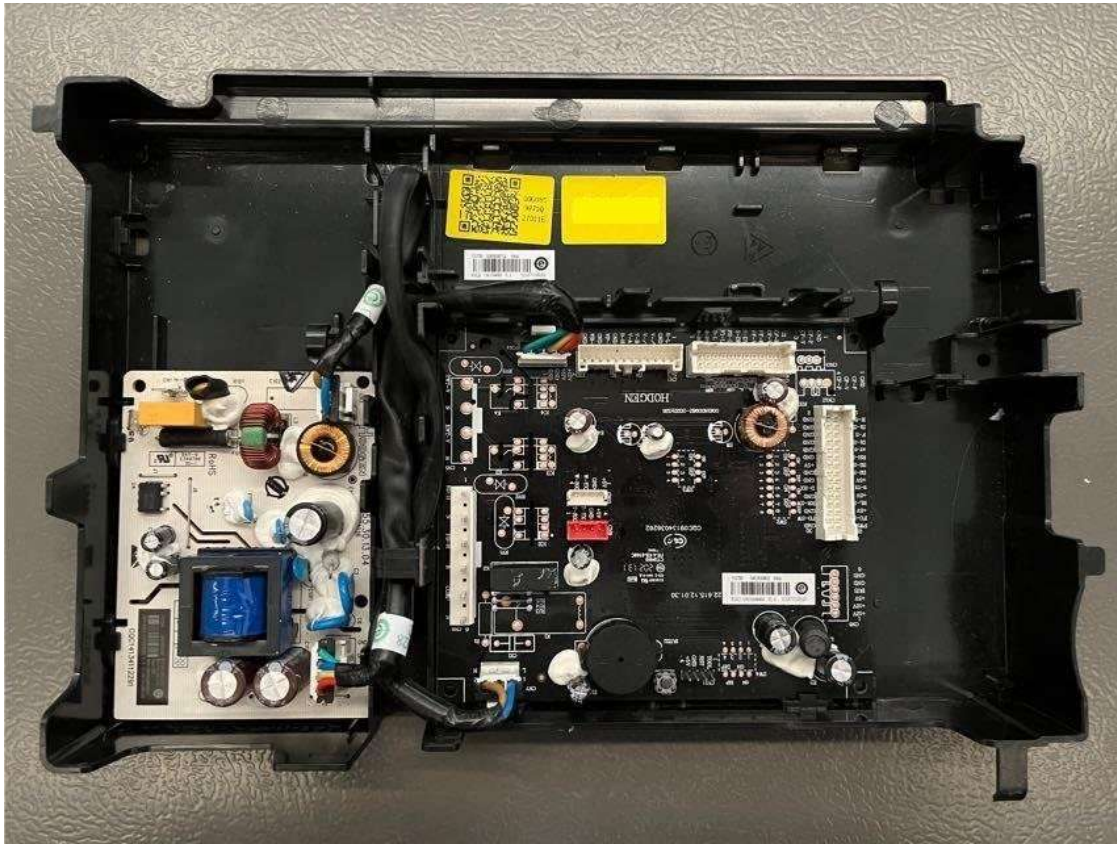

Control Board

CN7 L/N AC 230V

Press the button, the product can enter T mode, for it is danger, so it is safety to enter from display panel, it is main for the factory test

CN 6

CN 4 DC 12V

CN 3

CN 2

CN 1

16

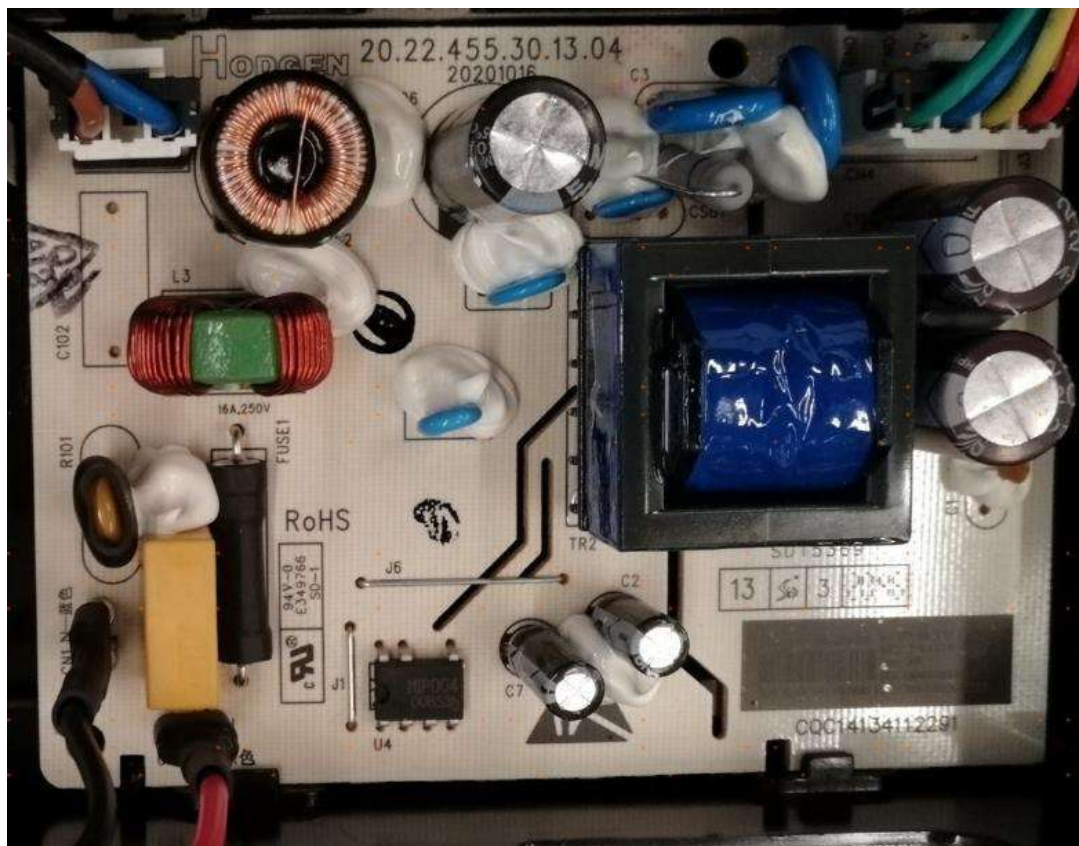

A close-up photograph of the control board, showing various connectors and components. Red dashed lines and arrows point from text boxes to specific locations on the board. The board is populated with numerous components, including capacitors, resistors, and integrated circuits. A large black circular component, likely a buzzer, is prominent in the center. The board is labeled with various identifiers such as 'COC09134036262' and 'HODGEN'. The board is connected to several cables, including a power supply cable and a data cable.

Power Board



Control Board(0061800982BG)

Connector name	Wire connecting (color)	Parts connecting	Position of parts	Normal working parameter
CN1	1 Black 2 Black 3 Gray 4 Gray 5 Brown 6 Brown 7 Blue 8 Blue 9 Green 10 White 11-16 NC 17 Red 18 Black 19 Blue 20 Purple 21 Orange	1-2 R Sensor 3-4 S Sensor 5-6 F Sensor 7-8 FD Sensor 9-10 RT Sensor 11-16 NC 17-20 Disp 21-23 RL-sw 24-28 NC 29-30 PWM+/PWM-	R/S/F/FD/RT Sensor Display Panel Ref.Door switch Compressor Signal	1-2: resistance 3-4: resistance 5-6: resistance 7-8: resistance 9-10: resistance 17-20: 5V(Display Panel)

	22 Black 23 Purple 24-28 NC 29 Red 30 Black			21-23: 5V (R door open/ closed) 29-30: Compressor Signal
CN2	1 Red 2 White 3 Yellow 4 Blue 5-14 NC 15 Red 16 Black 17 Yellow 18-22 NC	1-4 Damp 5-14 NC 15-16 FFAN 	Damp Unit assembly of air duct of Freezer	1-4 12V (Damp) 15-16 12V (F-FAN)
CN3	1 Red 2 Black 3-8 NC	1-2 LC LED 3-8 NC 	Refrigerator LED assembly of air duct of fridge	1-2 12V (LED)
CN4	1 Green 2 Blue 3 Yellow 4 Red	1-2 GND 3-4 DC 12V	Power DC 12V	1-2 GND 3-4 DC 12V
CN6	1-4 NC 5 Black 6 NC 7 Blue 8 NC 9 Red 10 NC 11 Brown	5.7 FD Heater 9.11 Compressor	Power AC 230V FD-Heater Compressor	5 AC 230V 7 GND 9 AC 230V 11 GND
CN7	1 Blue 2 Brown	1-2 Power AC 230V	Power AC 230V	1 L AC 230V 2 N

5-3 PCB pins no break off

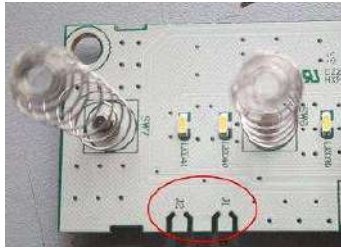

Chapter 6 Main Function Operating principle

6-1 Defrost system

6-1-1 defrost control :

According to the times of opening and closing the door and the time of the compressor cumulative working, the refrigerator has different frost timing .



6-1-2. the easily broken part in the defrost system :

- 1) Defrost fuse, it is on the middle of the evaporator, outer is plastic bushing, normally, it is conducting. If it is open, it is broken.
- 2) The connection between the defrost fuse or defrost heater and cabinet, if the connection terminal falls off or decline, poor contact will happen.
- 3) Defrost sensor, which locates at the top

6-2 REF Lamp



when the doors are opened, the REF lamp is on, when the doors are closed, the REF lamp is off.

Chapter 7 Control and display system

7-1 Control and display panel

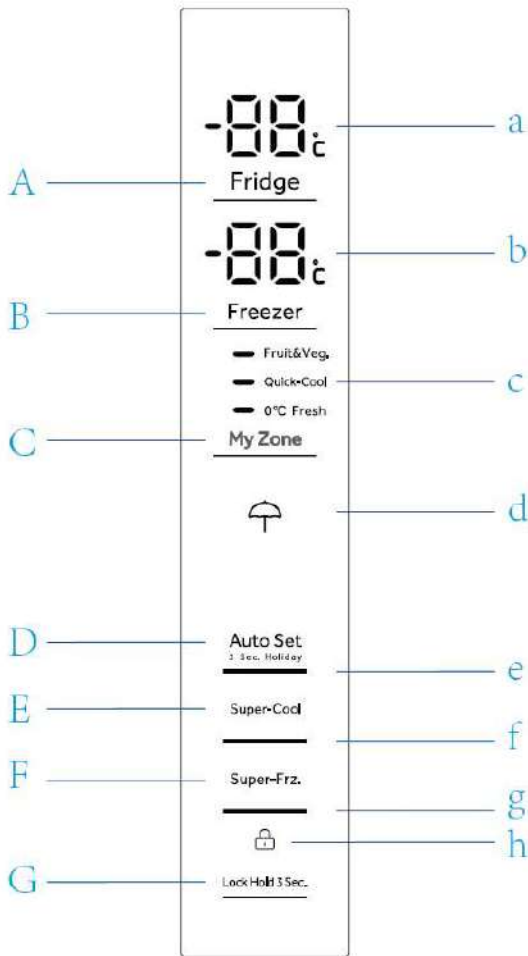

BUTTONS:

- A Fridge Temp selector
- B Freezer Temp selector
- C My Zone selector
- D Fuzzy function/Holiday function selects
- E Super Cool function selector
- F Super Frz. function selector
- G Setting/Panel lock selector

Indicators:

- a Fridge compartment
- b Freezer compartment
- c My Zone compartment
- d Holiday function compartment
- e Fuzzy function compartment
- f Super Cool function compartment
- g Super Frz. function compartment
- h Lock Hold function compartment

7-2 Function introduction (See User Manual)

(1) Initial powering on

When the refrigerator is connected to the power supply for the first time, the display panel lights. The refrigerator is 5 degrees Celsius and the freezer is -18 degrees Celsius by default. In the refrigerator, and the variable greenhouse display panel shows "Fruit&Veg. "..

(2) Auto Lock: The Display will be automatically deactivated and locked when no key is operated within 30s

after the Refrigerating Chamber Door and Freezing Chamber Door are closed.

Manual Lock: When the Display is unlocked, press and hold the Child Lock Key for 3s to lock the Display .

This locking operation is successful completed when the buzzer alarms and the illumination for Child Lock Indicator is activated. When no key is operated within 30s, the display is off (when the door is opened, the Child Lock Indicator extinguishes after 30 seconds).



Unlock: The Display will be illuminated in a locked mode when a Door is opened or a Key on Display is pressed. In this case, press and hold the Child Lock Key for 3s to unlock the Display. This unlocking operation is successful completed when the buzzer alarms and the illumination for Child Lock Indicator is deactivated.



(3) Adjust refrigerator compartment temperature (1~9°C)

- 1) When the Display is unlocked, press the Refrigerating Chamber Temperature Adjusting Key, represented by an alarm from the Buzzer, the Temperature Setting Mode can be activated.
- 2) Thereafter, each press on the Refrigerating Chamber Temperature Adjusting Key will decrease the temperature by 1 °C, accompanied by an alarm from the Buzzer. The refrigerating chamber is at 1 to 9 degrees Celsius and in such a loop;
- 3) After the temperature is set, the system will automatically confirm and save the set temperature if no button operation is done within 5 seconds.



(4) Adjust freezer compartment temperature (-14~-24°C)

1. When the Display unlocked, the Temperature Setting Mode can be activated, represented by an alarm from the Buzzer and the flicker of Freezing Chamber Temperature Indicator, by pressing the Freezing Chamber Temperature Adjusting Key.
2. Thereafter, each press on the Freezing Chamber Temperature Adjusting Key will decrease the temperature by 1°C, accompanied by an alarm from the Buzzer. The freezer chamber is at -14 to -24 degrees Celsius and in such a loop;



Precaution: After the temperature is set, if you do not press the button within 5 seconds, represented by an alarm from the Buzzer, and the current temperature value will be automatically confirmed and saved by the

system. After setting the temperature of Display, if there is no button operation within 25 seconds, it will display the actual temperature, the Display will extinguish after 5 seconds.

(5) Adjust My Zone Function

1) When the display screen is in unlocked status, press [My Zone Function Adjustment Button] once, the buzzer will beep once and the My Zone function icon indicates "Fruit & Veg.", "Quick Cool" and "0°C Fresh Keeping" are illuminated in order and corresponding function is activated;



(6) Auto Set Function

When the environment changes obviously, the Auto Set function can ensure the automatic normal operation of the refrigerator and freezer. The refrigerator can automatically adjust the temperature in the refrigerator and freezer according to the environmental temperature change.

- 1) When the display screen is in unlocked status, press [Auto Set Button], the buzzer will beep once and the [Auto Set Function Indicator Icon] will be illuminated, and the Auto Set function of the refrigerator will be activated.
- 2) When the [Auto Set Function Indicator Icon] is illuminated, press [Auto Set Button], the buzzer will beep once, the [Auto Set Function Indicator Icon] will extinguish, and the Auto Set function of the refrigerator will be inactivated.



Note: In the **Auto Set** status, it is not allowed to adjust the refrigerator and freezer temperatures. While pressing the [Refrigerator Temperature Adjustment Button] or [Freezer Temperature Adjustment Button] for temperature adjustment, the [Auto Set Button] will blink with alarm sound in order to remind that this operation is not allowed.

In the **Auto Set** status, while setting the Super-Frz. or holiday function, the [Auto Set Function Indicator Icon] will extinguish, and the **Auto Set** function will be inactivated automatically.

(6) Holiday Function

- 1) When the display screen is in unlocked status, press [Super-Cool Function Button] and last 3 seconds, the buzzer will beep once and the [Holiday Function Indicator Icon] will be illuminated, and the holiday function will be activated.
- 2) When the [Holiday Function Indicator Icon] is illuminated, press [Super-Cool Function Button] and last 3 seconds the buzzer will beep once and the [Holiday Function Indicator Icon] will extinguish, and the holiday function will be inactivated.

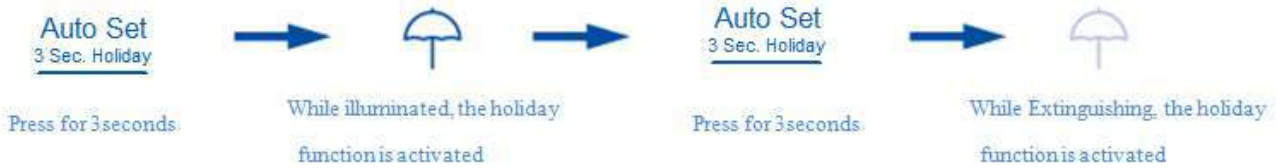

Note: In the holiday status, it is not allowed to adjust the Refrigerator Temperature. While pressing the [Refrigerator Temperature Adjustment Button] for temperature adjustment, the [Holiday Button] will blink with alarm sound in order to remind that this operation is not allowed. In the holiday status, while setting the Auto Set function, the [Holiday Function Icon] will extinguish, and the holiday function will be inactivated automatically.

(7) Super-Cool function

1. When the Display is unlocked, press [Super-Cool Button], the buzzer will beep once and the Super-Cool Function Indicator illuminates and the Super-Cool function starts. In this state, the refrigerator works as set. After entering the Super-Cool function for at least 3 hours, the function will automatically withdrawn.

2. When the Super-Cool Function Indicator illuminates, press [Super-Cool Button], the buzzer will beep once and the Super-Cool Function Indicator extinguishes so that the Super-Cool function ends.



Pr
caution: In the state of Super-Cool, the refrigerating temperature cannot be adjusted. If you press the Refrigerating Temperature Adjusting Button, the Super-Cool Function Indicator will flicker to prompt the operation cannot be carried out. In the state of Super-Cool, if the intelligent function is set, the Super-Cool Function Indicator distinguishes, and the Super-Cool, function will automatically withdrawn.

(8) Super-Frz. function

Super-Frz. function is designed to preserve the nutrition of frozen food which can freeze the food deeply in the shortest time.

- 1) When the display screen is in unlocked status, press [Super-Frz. Button], the buzzer will beep once and the [Super-Frz. Function Button] will be illuminated, and the Super-Frz. function will be activated. In this condition, the freezer will operate based on the setting and automatically exit the Super-Frz. function after 50 hours of operation in Super-Frz. function.
- 2) When the [Super-Frz. Function Icon] is illuminated, press [Super-Frz. Function Icon], the buzzer will beep once and the [Super-Frz. Function Icon] will extinguish, and the Super-Frz. function will be inactivated.



Note: In the Super-Frz. status, it is not allowed to adjust the freezer temperature. While pressing the [Freezer

Temperature Adjustment Button] for temperature adjustment, the [Super-Frz. Function Icon] will blink with alarm sound in order to remind that this operation is not allowed. In the Super-Frz. status, while setting the smart function, the [Super-Frz. Function Icon] will extinguish, and the Super-Frz. function will be inactivated automatically.

(9) Door open alarm:

If the refrigerator compartment door is open for 1min, the refrigerator will sound the alarm to warn the user and the alarm will not stop until the door is closed.

(10) Restoration Memory after Power-Off

The instant working state when the power is cut off will be memorized and the refrigerator will continue to work according to the settings made before power off when the power is recovered.

Chapter 8 Quick check and Self-test model

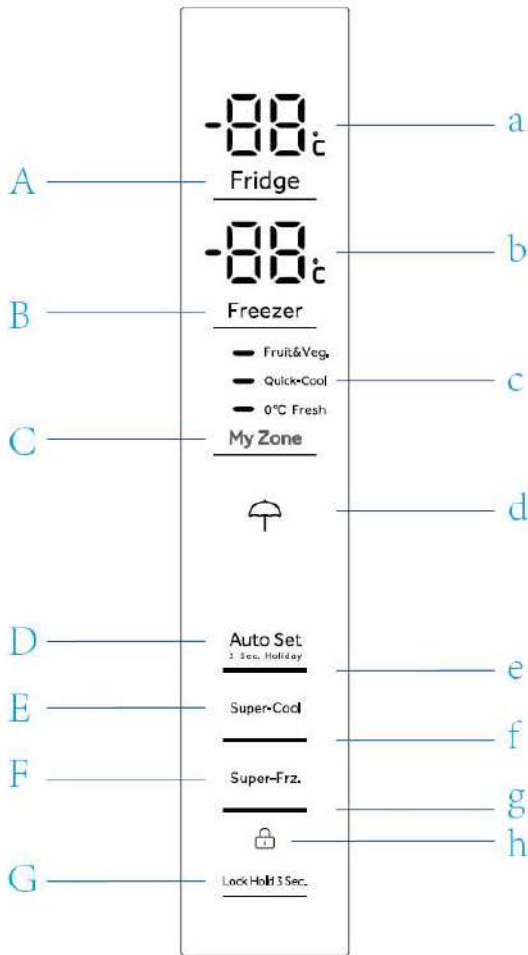

BUTTONS:

- A Fridge Temp selector
- B Freezer Temp selector
- C My Zone selector
- D Fuzzy function/Holiday function selects
- E Super Cool function selector
- F Super Frz. function selector
- G Setting/Panel lock selector

Indicators:

- a Fridge compartment
- b Freezer compartment
- c My Zone compartment
- d Holiday function compartment
- e Fuzzy function compartment
- f Super Cool function compartment
- g Super Frz. function compartment
- h Lock Hold function compartment

8-1 Fault Codes and Query Method

How to enter: in lock mode, press “Fridge” button and click three times “My zone” to show fault codes. Press lock button to check the next fault code.

How to quit: The same steps as enter, or it will automatically quit after 1 minutes without operation.

8-2 Fault content description

HTR5720ENMG (0061800982BG)

NO	program	code	description	remark
1	normal	--/--	HTR5720ENMG	button action normal
2	Ambient temp. sensor malfunction	F2	Ambient temp. sensor short circuit or open circuit	Check the connection with all sensors
3	Refrigerator sensor malfunction	F3	Refrigerator sensor short circuit or open circuit	

4	Dry area sensor malfunction	F5	Dry area sensor short circuit or open circuit	
5	freezer sensor malfunction	F4	Freezer sensor short circuit or open circuit	
6	Freezer defrost sensor malfunction	F6	Freezer defrost sensor short circuit or open circuit	
7	Communication malfunction	E0	2 min communication failure	
8	Freezer fan malfunction	E1	See freezer fan lock judgement (not applicable to AC fan)	Cable/Driver IC/TR malfunction
9	Freezer defrost malfunction	Ed	After defrost heater works 75 minutes, defrost sensor fails to reach desired temp.	
10	Refrigerator switch	P3	Switch fault	

8-3 Sensor layout plan

		
Sensor for refrigerator space	Sensor for Chill Chamber	Sensor for freezer space
		
Defrost sensor of freezer	Ambient temperature sensor	
Name	Label	Location
Sensor for refrigerator space	R SNR	Middle left of refrigerator air duct
Sensor for Chill Chamber	S SNR	Lower Left of refrigerator air duct, rack's location
Sensor for freezer space	F SNR	Upper left of freezer air duct
Defrost sensor of freezer	F/D SNR	On the evaporator of freezer
Ambient temperature sensor	RT- SNR	Refrigerator left hinged box

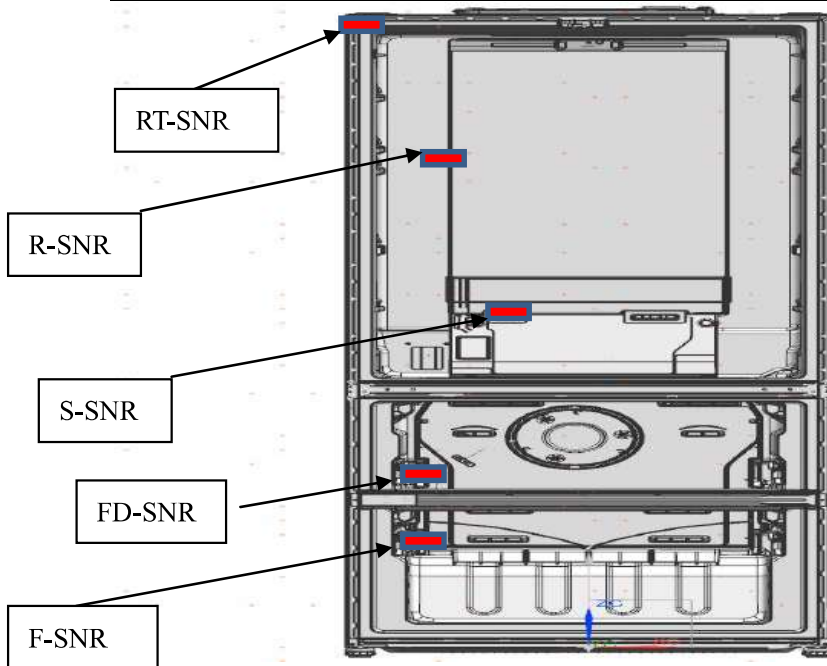

8-4 Test mode

How to enter and quit: In unlocked mode, press “Fridge” button and click five times “Super-Frz.” to show Test mode. Press lock button to toggle through the test modes T1 -> T2 -> T3 -> quit.

- Compressor ON, Freezer Fan ON, Dampers Open, Heaters OFF, o
- Fridge & Freezer are lit. Temperature display shows T1.

- T1 status will continue until you continue to press the lock key to manually exit or exit after 100 hours.

T2 mode: FREEZER COMPARTMENT FORCED DEFROST

- Freezer Compartment Defrost Heater ON, Compressor OFF, Fans OFF, Dampers closed.
- Fridge & Freezer are lit. Temperature display shows T2
- If Defrost Sensor $\geq 7^{\circ}\text{C}$, Defrost heater on for 10 seconds.
- If Defrost Sensor $< 7^{\circ}\text{C}$, Defrost heater on and turns off when Defrost Sensor reaches 7°C (Heater on for 75 minutes max.)
- With faulty Freezer Defrost Sensor, Freezer Defrost Heater on for 30 minutes max.
- To manually exit, continue pressing lock key.





8-5 Demo mode

How to enter: In unlocked mode, press “Freezer” button and click five times “Super-Frz.” to show Demo mode.

How to quit: The same steps as enter, or it will automatically quit after 1 minutes without operation.

Demo mode, Only display board and Refrigerator lamp can normal control, other load all shield.

Chapter 9 Electrical Parts specifications

No.	Spare parts	Model	The main parameters	Picture
1	Compressor	VTH1113Y	Power : 38.5~126.5W Energy Efficiency Ratio: 1.58~1.78 Refrigerating Capacity: 61.1~214.3W Operating Current: 0.31~0.98A Starting Current: 2.1A R: 0.418k Ω ~ 1.374 k Ω	
2	Frz. Fan	GW12E12MS1MB-5 2Z32	Volt: 12V Power: 2 \pm 0.3W Resistance: Connector(yellow and red) R: 72 Ω	
3	Frz. Defrost heater	0064001962	Volt: 230V Power: 1.80W R: 0.294k Ω	
4	Damper	0064001405	Volt: 12V Power: 0.5W R: 288 Ω	

Chapter 10 Trouble shooting

10-1. Typical faults and solutions

1) Refrigeration not functioning

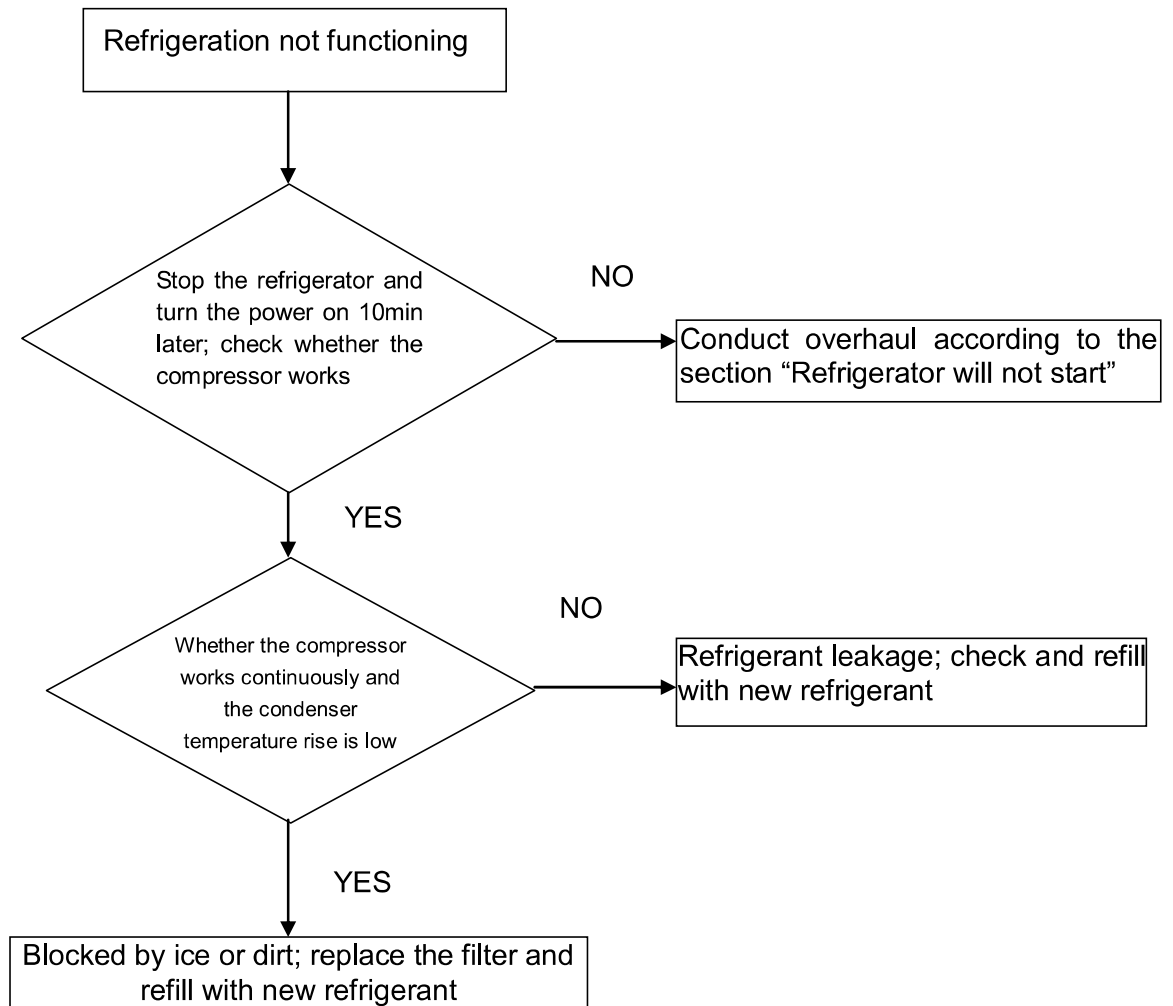

Notes:

A. The refrigerant for refilling shall be consistent with the original.

B. Isobutane and refrigerant shall be handled in strict accordance with the requirements of operation procedures.

2) Refrigerator will not stop

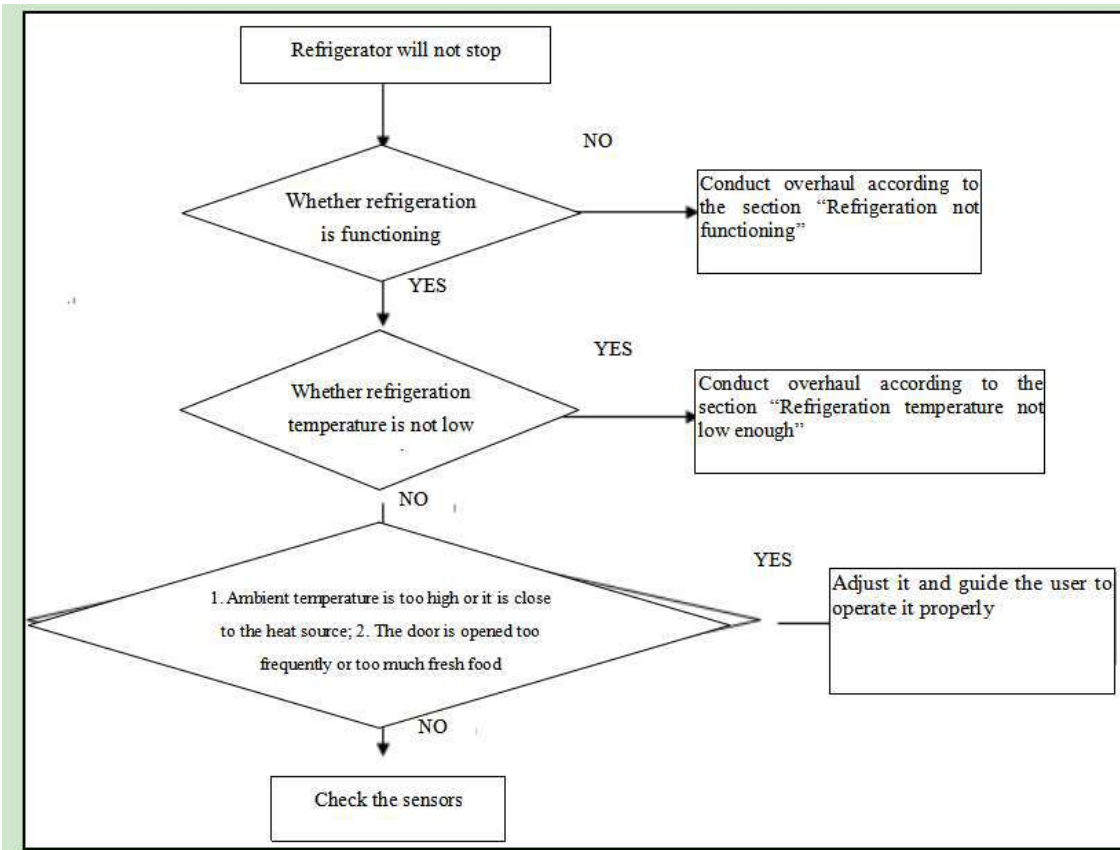

3) Refrigeration temperature not low enough

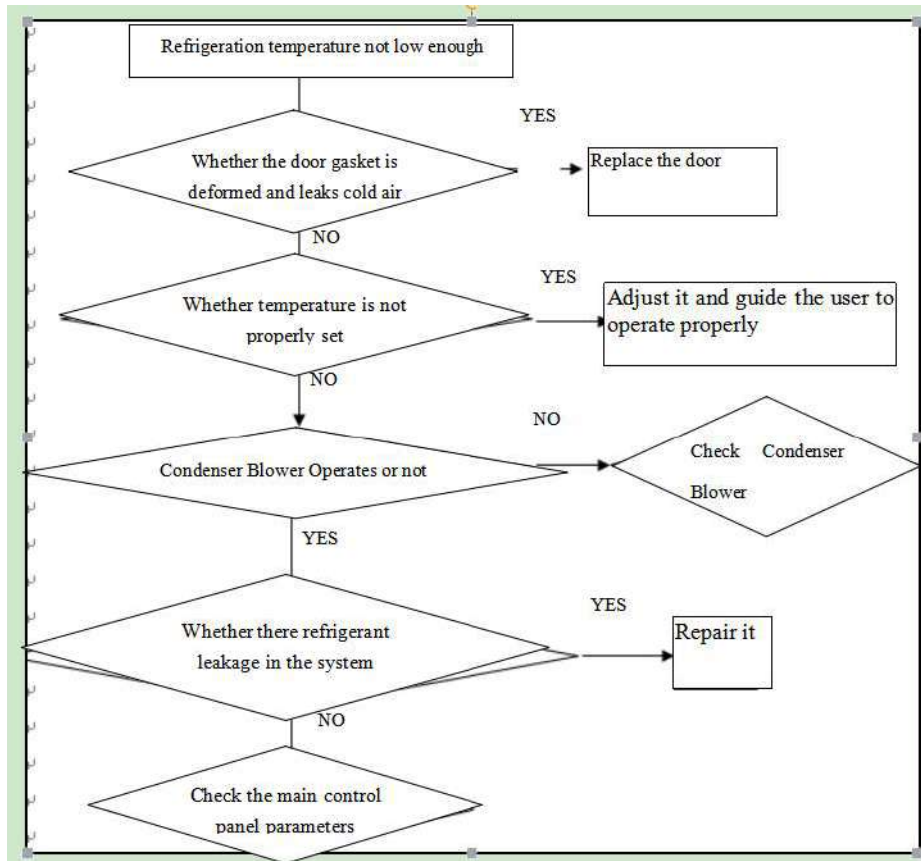

4) Refrigerator will not start

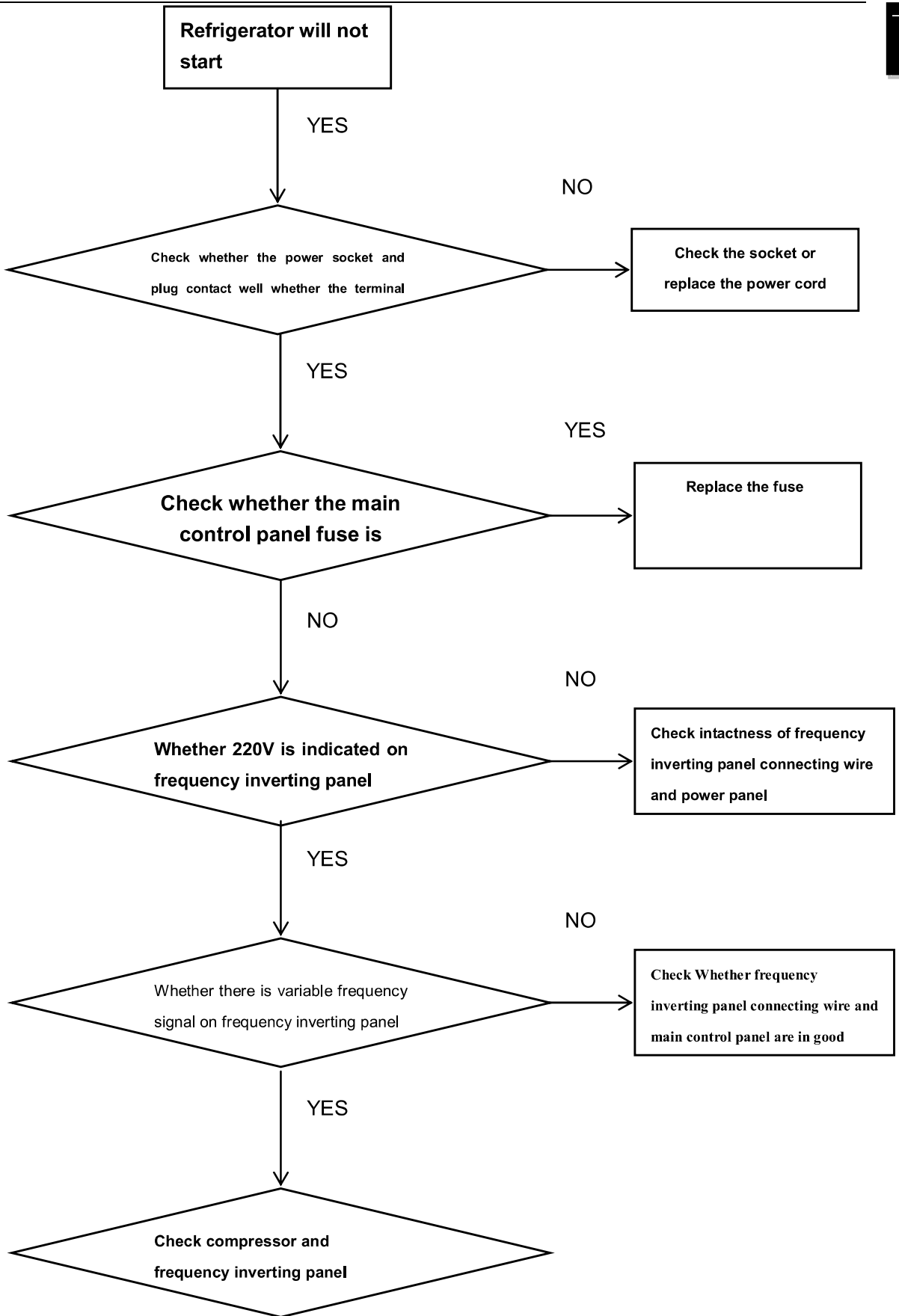

5) Defrost not functioning

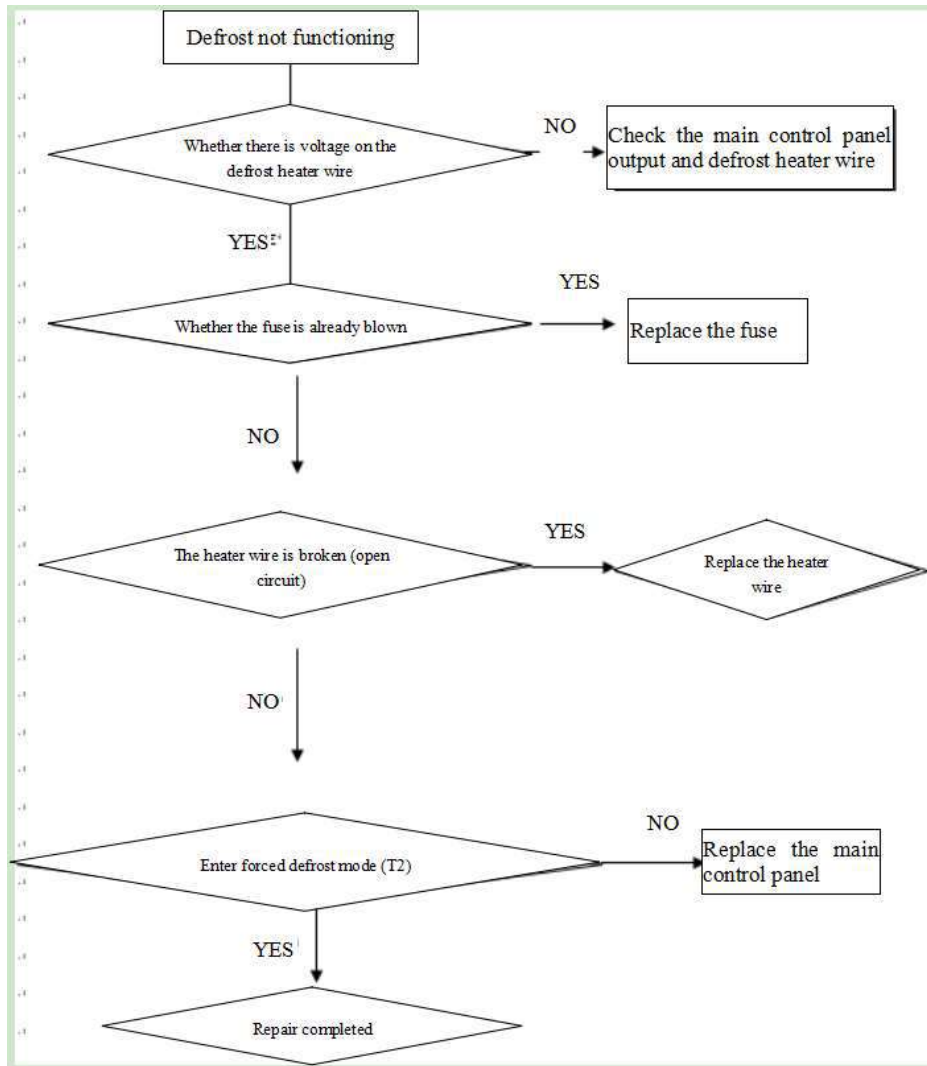

6) Fan breakdown

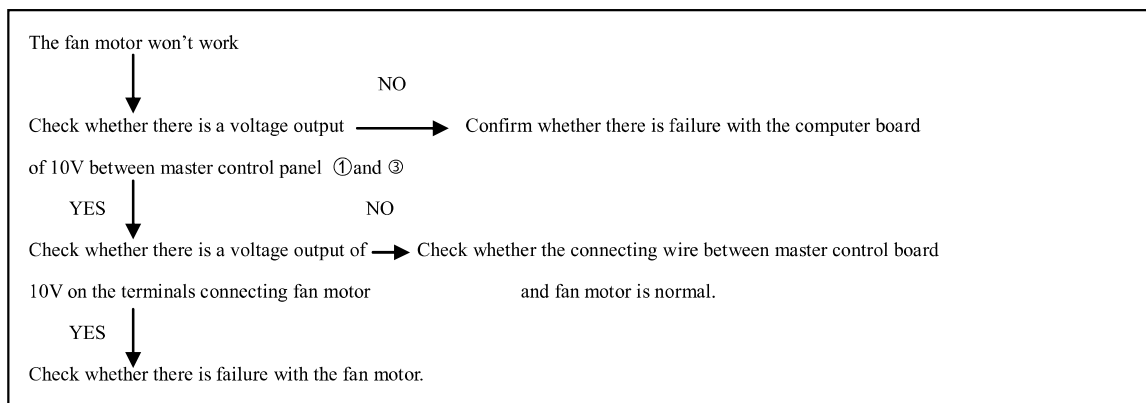

Note: please check whether refrigerator door closed or not . If not, the fan won't work.

10-2. Answers to frequently asked questions

① The refrigerator does not work

- Check whether the power is connected (the plug, socket, fuse, etc.).
- Whether the supply voltage is too low.

② The refrigerator produces noise

- Since the refrigerant flows in the pipeline, it will produce noise and it is normal.
- In the case of initial use, the refrigerator is not stable and will drone loudly. It is normal.
- The evaporator and pipeline will produce snaps due to thermal expansion and contraction when the refrigerator is working. It is normal.
- The relays and other elements will act and produce clicks when the refrigerator starts and stops working. It is normal.

③ The internal temperature is not low enough

- Whether the temperature is set too high.
- The door not tightly closed or opened frequently or for excessively long period of time.
- The refrigerator is placed where it is exposed to direct sunlight or too close to such heat sources as furnace and heating.
- Poor ventilation: Check whether the plates at both sides of the refrigerator or the steel plate on the back is blocked or these places are dirty.

④ Loud noise

- Check whether the ground is level and the refrigerator is stably positioned.
- The refrigerator has produce noise because certain part is in contact with other objects or the wall.
- Check whether power of the refrigerator is off.

⑤ Operation of refrigerator keys fails

- Check whether power of the refrigerator is off.
- Check for improper key operation. Please operate properly according to the section "Function introduction".

⑥ The temperature value indicated changes automatically

- The refrigerator compartment temperature indicated changes: it is normal in the operating process of the refrigerator.
- The temperature indicated changes under the SMART mode: when the ambient temperature changes, the refrigerator will automatically adjust the temperature. It is normal.

⑦ The refrigerator body temperature is high

- Since the refrigerator dissipate heat through the plates on both sides, such parts will have high temperature and it is normal.
- In the case of initial use, the refrigerator body temperature may be high due to long working hours. It is normal.

⑧ The compressor runs for too long period

- In the case of initial use, it will run for a long time and it is normal.
- A large amount of food is put in the refrigerator one time for cooling.
- The weather is hot or door frequently opened.
- The door is not closed tightly.
- The temperature is set too low. See "Manual adjustment of temperature".

⑨ **The refrigerator body temperature is high and the lamp does not shine**

- Check whether the lamp is damaged.
- Check whether the power is on.

Sincere forever

Haier Group

Haier Industrial Park, No.1, Haier Road

266101, Qingdao, China

<http://www.haier.com>

Please login the Haier technical support website for more product information.

<http://community.haierdealer.com/km>