

CDP-395/M31

SERVICE MANUAL

AEP Model

CDP-395/M31

E Model

Australian Model

CDP-M31



Photo: CDP-395

Model Name Using Similar Mechanism	CDP-291/391
CD Mechanism Name	CDM14-5BD1
Base Unit Name	BU-5BD1

SPECIFICATIONS

Compact disc player

Frequency response	2 Hz - 20 kHz \pm 0.5 dB
Signal to noise ratio	More than 100 dB
Dynamic range	More than 97 dB
Harmonic distortion	Less than 0.004%
Channel separation	More than 95 dB

Outputs

LINE OUT (FIXED) (phono jacks)	Output level 2 V (at 50 kilohms) Load impedance over 10 kilohms
LINE OUT (VARIABLE) (phono jacks)	Output level max. 2 V (at 50 kilohms) Load impedance over 50 kilohms
PHONES (for CDP-395)	Output level max. 10 mW
HEADPHONES (for CDP-M31) (stereo phone jack)	Load impedance 32 ohms

General

	CDP-395	CDP-M31
Power requirements	AEP Model (CDP-395/CDP-M31) 220 - 230 V AC, 50/60 Hz Australian Model (CDP-M31) 240 V AC, 50 Hz E Model (CDP-M31) 110, 120, 220 or 240 V AC, adjustable, 50/60 Hz	
Power consumption	12 W	12 W
Dimensions (approx., including projections)	430 x 100 x 280 mm (w/h/d) (17 x 4 x 11 ¹ / ₈ inches)	355 x 95 x 305 mm (w/h/d) (14 x 3 ³ / ₄ x 12 ¹ / ₈ inches)
Weight (approx.)	3.5 kg (7 lbs 12 oz)	3.2 kg (7 lbs 1 oz)

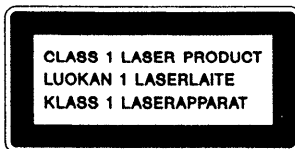

This Compact Disc player is classified as a CLASS 1 LASER product. The CLASS 1 LASER PRODUCT label is located on the rear exterior.

- Continued on next page -

COMPACT DISC PLAYER
SONY®



Supplied accessories

Audio cord	1
	(2 phono plugs – 2 phono plugs)
Remote commander	1
R6(size AA) batteries	2
AC plug adaptor (for some areas)	1

Remote commander RM-D391



Remote control system	Infrared control
Power requirements	3 V DC with two R6 (size AA) batteries
Dimensions	Approx. 40×20×175 mm (w/h/d) (1 ³ / ₄ ×1 ³ / ₁₆ ×7 inches)
Weight	Approx. 95 g (4 oz) Including batteries

Design and specifications subject to change without notice.

TABLE OF CONTENTS

<u>Section</u>	<u>Title</u>	<u>Page</u>
	Specifications	1
	Model Identification	3
1.	SERVICING NOTES	3
2.	GENERAL	
	Location of Controls	4
3.	DISASSEMBLY OF BASE UNIT	5
4.	ELECTRICAL BLOCK CHECKING	
	S Curve Check	6
	RF Level Check	6
	E-F Balance Check	6
	RF PLL Free-run Frequency Check	7
	Focus/Tracking Gain	7
5.	DIAGRAMS	
5-1.	IC Pin Function and IC Block Diagrams	8
5-2.	Block Diagram	12
5-3.	Printed Wiring Boards	16
5-4.	Schematic Diagram	21
6.	EXPLODED VIEWS	25
7.	ELECTRICAL PARTS LIST	29

SAFETY-RELATED COMPONENT WARNING!!

COMPONENTS IDENTIFIED BY MARK  OR DOTTED LINE WITH MARK  ON THE SCHEMATIC DIAGRAMS AND IN THE PARTS LIST ARE CRITICAL TO SAFE OPERATION. REPLACE THESE COMPONENTS WITH SONY PARTS WHOSE PART NUMBERS APPEAR AS SHOWN IN THIS MANUAL OR IN SUPPLEMENTS PUBLISHED BY SONY.

SECTION 1 SERVICING NOTES

MODEL IDENTIFICATION

— Specification Label —

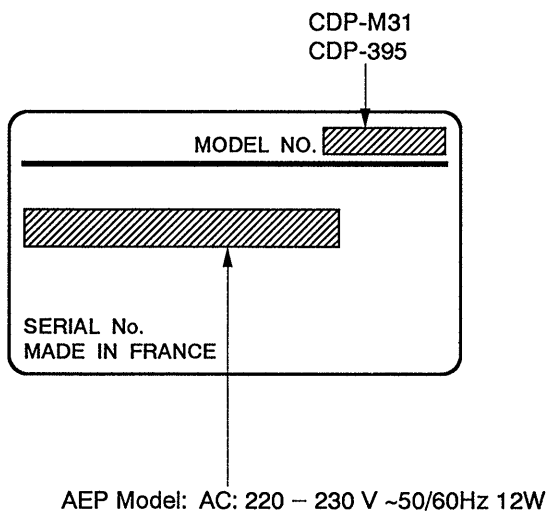
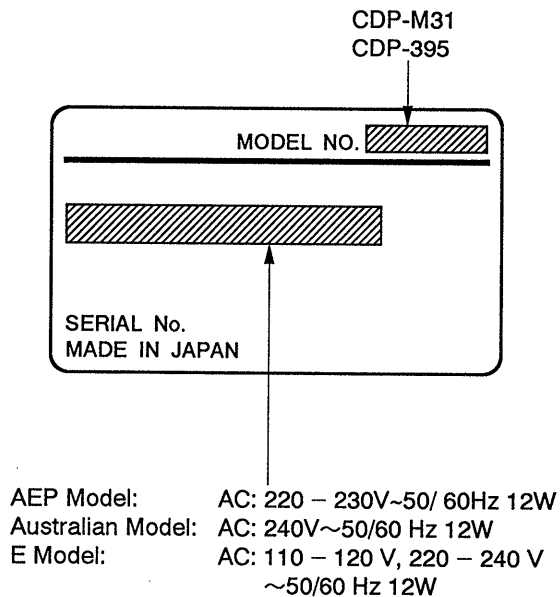

NOTES ON HANDLING THE OPTICAL PICK-UP BLOCK OR BASE UNIT

The laser diode in the optical pick-up block may suffer electrostatic breakdown because of the potential difference generated by the charged electrostatic load, etc. on clothing and the human body.

During repair, pay attention to electrostatic breakdown and also use the procedure in the printed matter which is included in the repair parts.

The flexible board is easily damaged and should be handled with care.

NOTES ON LASER DIODE EMISSION CHECK

The laser beam on this model is concentrated so as to be focused on the disc reflective surface by the objective lens in the optical pick-up block. Therefore, when checking the laser diode emission, observe more than 25 cm away from the objective lens.

Laser component in this product is capable of emitting radiation exceeding the limit for Class 1.

Note

This appliance conforms with EEC Directive 87/308/EEC regarding interference suppression.

SECTION 2 GENERAL

Location of Controls

• FRONT PANEL

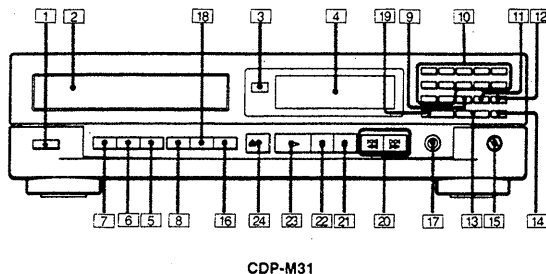
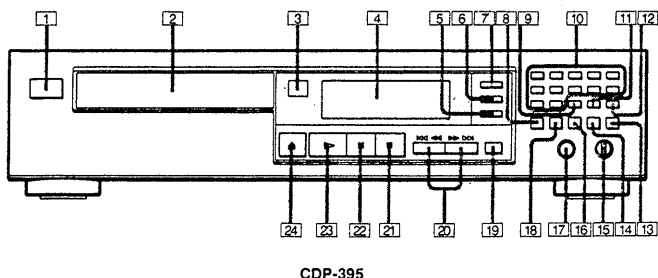

- 1 POWER switch
- 2 Disc tray
- 3 Remote sensor
- 4 Display window
- 5 PROGRAM button
- 6 SHUFFLE button
- 7 CONTINUE button
- 8 TIME button
- 9 CHECK (program check) button
- 10 Numeric buttons
- 11 CLEAR (program clear) button
- 12 > 12 (over 12) button
- 13 MUSIC SCAN button
- 14 PEAK SEARCH button (for CDP-395)
P.SEARCH button (for CDP-M31)
- 15 LINE OUT/PHONE LEVEL control
- 16 FADER button
- 17 PHONES jack (for CDP-395)
HEADPHONES jack (for CDP-M31)
- 18 REPEAT button
- 19 EDIT/TIME FADE button
- 20 ◀◀◀/▶▶▶ (AMS*/RMS**/manual search) buttons
- 21 ■ (stop) button
- 22 || (pause) button
- 23 ▶ (play) button
- 24 ▲ (open/close) button

* AMS is the abbreviation of Automatic Music Sensor.
** RMS is the abbreviation of Random Music Sensor.

• REMOTE COMMANDER

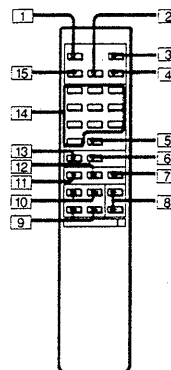

- 1 M.SCAN (music scan) button
- 2 SHUFFLE button
- 3 FADER button
- 4 PROGRAM button
- 5 > 10 (over 10) button
- 6 REPEAT button
- 7 ■ (stop) button
- 8 LINE OUT LEVEL +/- buttons
- 9 ◀◀▶▶ (manual search) buttons
- 10 ◀◀◀▶▶ AMS buttons
- 11 ▶ (play) button
- 12 || (pause) button
- 13 TIME button
- 14 Numeric buttons
- 15 CONTINUE button

SECTION 3 DISASSEMBLY OF BASE UNIT

Note :

Follow the disassembly procedure in the numerical order given.

- ① Turn the cam to the direction of arrow (Counter clock wise) by minus screw driver.
- ② Take off the disc table.
- ③ Remove the yoke bracket.
- ④ Remove the MD (BU-5BD1) to the direction of arrow.

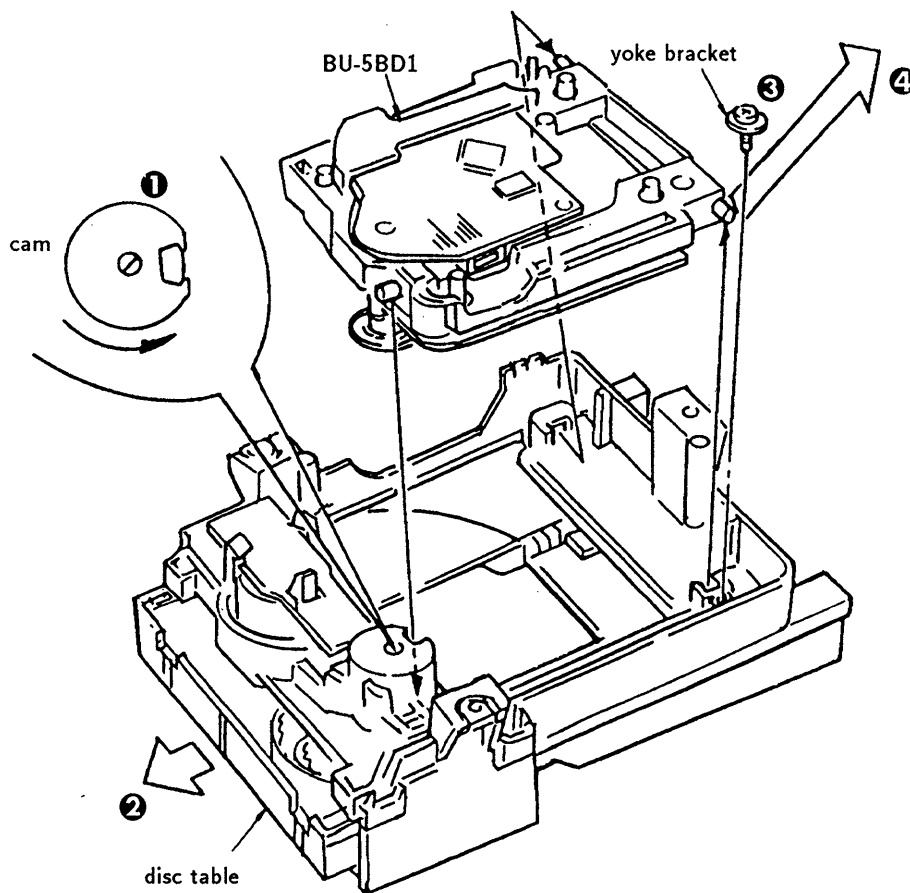

SECTION 4 ELECTRICAL BLOCK CHECKING

Note :

1. CD Block basically constructed to operate without adjustment. Therefore, check each item in order given.
2. Use YEDS-18 disc (3-702-101-01) unless otherwise indicated.
3. Use the oscilloscope with more than $10M\Omega$ impedance.
4. Clean an object lens by an applicator with neutral detergent when the signal level is low than specified value with the following checks.

S Curve Check

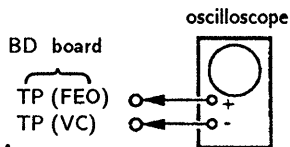

Procedure :

1. Connect oscilloscope to test point TP (FEO) on BD board.
2. Connect between test point TP (FES) and TP (VC) by lead wire.
3. Turned Power switch on and actuate the focus serch. (actuate the focus serch when disc table is moving in and out.)
4. Check the oscilloscope waveform (S curve) is symmetrical between A and B. And confirm peak to peak level within $3 \pm 1V_{p-p}$.

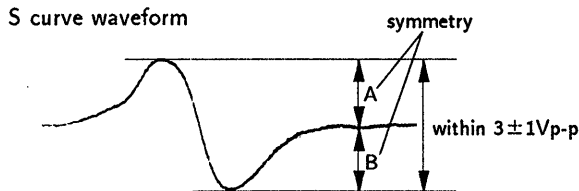

5. After check, remove the lead wire connected in step 2.

Note : • Try to measure several times to make sure that the ratio of A : B or B : A is more than 10 : 7.

• Take sweep time as long as possible and light up the brightness to obtain best waveform.

RF Level Check

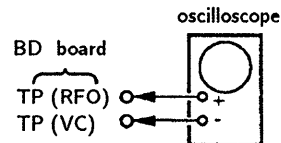

Procedure :

1. Connect oscilloscope to test point TP (RFO) on BD board.
2. Turn Power switch on.
3. Put disc (YEDS-18) in and playback.
4. Confirm that oscilloscope waveform is clear and check RF signal level is correct or not.

Note :

Clear RF signal waveform means that the shape “◇” can be clearly distinguished at the center of the waveform.

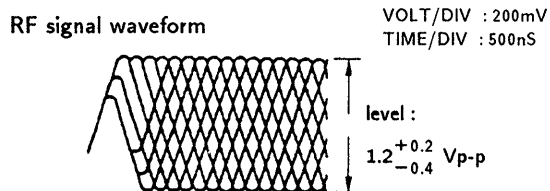

E-F Balance Check

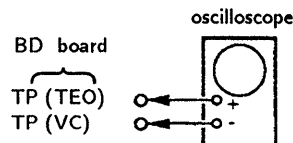

Procedure :

1. Connect test point TP (ADJ) to ground and TP (TES) to TP (VC) with lead wire.
2. Connect oscilloscope to test point TP (TEO) on BD board.
3. Turn Power switch on.
4. Put disc (YEDS-18) in and playback.
5. Confirm that the oscilloscope waveform is symmetrical on the top and bottom in relation to 0V, and check this level.

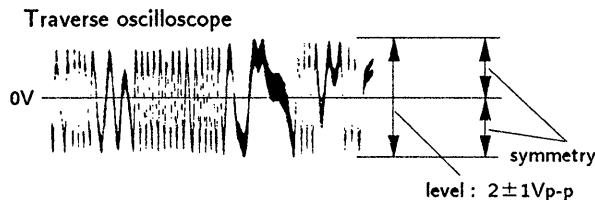

6. Remove the lead wire connected in step 1.

RF PLL Free-run Frequency Check

Procedure :

1. Connect frequency counter to test point (PLCK) with lead wire.

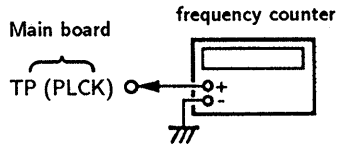

2. Turn Power switch on.
3. Confirm that reading on frequency counter is
4. 3218MHz.

Focus/Tracking Gain

This gain has a margin, so even if it is slightly off. There is no problem.

Therefore, do not perform, this adjustment.

Please note that it should be fixed to mechanical center position when you moved and do not know original position.

Adjustment Location ;

[MAIN BOARD] – Component Side –

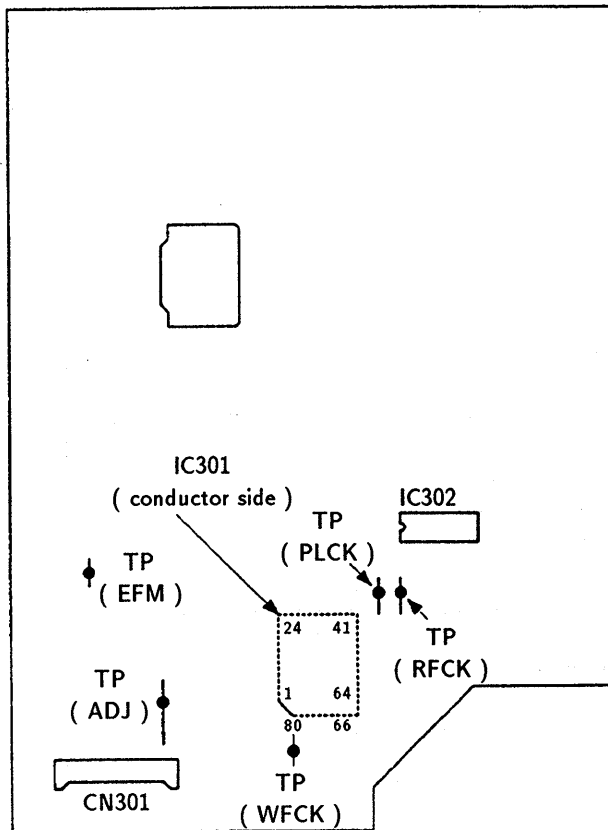

**Adjustment Locations :
[BD board]**

— conductor side —

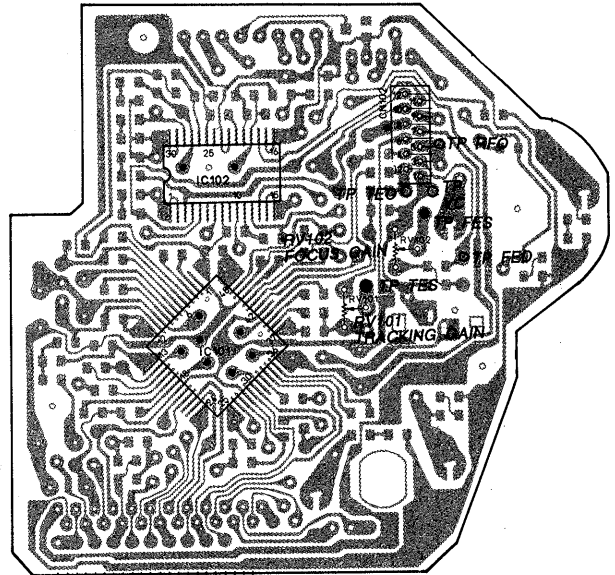

SECTION 5

DIAGRAMS

5-1. IC PIN FUNCTION AND IC BLOCK DIAGRAMS

● IC101 (CXA1372Q) PIN FUNCTION

Pin No.	Pin Name	I/O	Description
1	VC	—	GND when two (\pm) dual power supplies are in use, or the center voltage (2.5V) when a single power supply is in use.
2	FGD	I	Time constants for gain switching in normal mode/down mode and for focus gain are connected between the FGD and FS3 pins.
3	FS3	I	
4	FLB	I	The capacitor for low frequency boost in the focus servo loop is connected.
5	FEO	O	Focus drive output.
6	FE—	I	Inverted input to focus amplifier.
7	SRCH	I	Time constants to generate the focus search waveform are connected.
8	TGU	I	Time constants for gain switching in normal mode/up mode and for tracking gain are connected between TGU pin and TG2 pin.
9	TG2	I	
10	AVCC	—	Analog power supply (5V when \pm dual power supplies are in use, 5V when a single power supply is in use.)
11	TAO	O	Tracking drive output.
12	TA—	I	Inverted input to tracking amplifier.
13	SL+	I	Non-inverted input to sled amplifier.
14	SLO	O	Sled drive output.
15	SL—	I	Non-inverted input to sled amplifier.
16	ESET	I	The 610k Ω phase compensator resistor is connected to this pin.
17	ISET	I	The current setting resistor is connected to this pin.
18	SSTOP	I	The limit switch is connected to this pin.
19	AVEE	—	Analog power supply (–5V when \pm dual power supplies are in use, or GND when a single power supply is in use.)
20	DIRC	I	Direct control pin.
21	LOCK	I	Sled run-away prevention circuit operates when this signal is "L".
22	CLK	I	Serial data transfer clock input that is supplied from CPU (or DSP).
23	XLT	I	Latch input from CPU (or DSP).
24	DATA	I	Serial data input from CPU (or DSP).
25	XRST	I	System reset. "L" to reset.
26	C.OUT	O	Output to tracking counter.
27	SENS	O	SENS output.
28	DGND	—	Digital ground (GND). (GND when \pm dual power supplies are in use. GND when a single power supply is in use.)
29	MIRR	O	Mirror output.
30	DFCT	O	Defect output. "H" when defective.
31	ASY	I	Auto-assymetry control input.
32	EFM	O	EFM comparator output.
33	FOK	O	Focus OK.
34	CC2	I	Defect-bottom-hold input (input by capacitive coupling).
35	CC1	O	Defect-bottom-hold output.
36	DVCC	—	Digital power supply. (+5V when \pm dual power supplies in use. +5V when a single power supply is in use.)
37	CB	I	The defect-bottom-hold capacitor is connected to this pin.
38	CP	I	The mirror hold capacitor is connected to this pin.
39	RF1	I	RF signal input (input by capacitive coupling).
40	RF0	I	RF signal input (input by DC coupling).
41	DVEE	—	Digital power supply (–5V when \pm dual power supplies are in use. GND when a single power supply is in use.)
42	TZC	I	Tracking zero-cross comparator input.
43	TE	I	Tracking error input.
44	TDFCT	I	The defect prevention hold capacitor is connected to this pin.
45	ATSC	I	Anti-shock input.
46	FZC	I	Focus zero-cross comparator input.
47	FE	I	Focus error input.
48	FDFCT	I	The defect prevention hold capacitor is connected to this pin.

● IC401 (CXP50112-097Q) PIN FUNCTION

Pin No.	Pin Name	I/O	Description
1 - 4	—	—	Not used (open).
5 - 20	S1 -S16	O	Segment output to FL tube.
21 - 28	1G - 8G	O	Common output to FL tube.
29	SCOR	I	Subcode sync signal S0 + S1 detection input from IC301 (CXD2500AQ).
30	—	—	Not used (open).
31	+5V	—	+5V
32	RST	I	Reset input.
33	+5V	—	+5V
34	VDD	—	Power voltage terminal (+5V).
35 - 40	KEY0 - KEY5	I	Key A/D input.
41	—	—	Not used (Ground).
42	TIMER SW	I	Auto play select input (Auto play "L").
43	—	—	Not used (Ground).
44	CLK	O	Serial data transfer clock output to IC301 (CXD2500AQ).
45	DATA	O	Serial data output to IC301 (CXD2500AQ).
46	—	—	Not used (Ground).
47	FOK	I	Focus OK signal input from IC101 (CXA1372Q).
48	GFS	I	Frame sync signal clock status input from IC301 (CXD2500AQ).
49	SUBQ	I	Subcode (Q data) serial input from IC301 (CXD2500AQ).
50	SQCLK	O	Subcode (Q data) readout clock output to IC301 (CXD2500AQ).
51	XLT	O	Serial data latch output.
52	PRGL	O	Attenuate data latch clock output to IC302 (CXD2554P).
53	LDON	O	Laser diode ON/OFF select output of optical pick-up.
54	AMUT	O	Muting output for IC301 (CXD2500AQ) and Q344 (2SC3399). Muting on by "H", Muting off by "L".
55 - 58	B0 - B3	—	Not used (Ground)
59	DEFECT SW	O	Defect circuit ON/OFF select output to IC101 (CXA1372Q).
60	—	—	Not used (open).
61	SENSE	I	SENS signal input from IC301 (CXD2500AQ).
62	RMC	I	Remote control signal input.
63	INSW	I	Input for loading out switch.
64	OUTSW	I	Output for loading in switch.
65	ADJ	I	Test mode input. GFS check will not activate by "L".
66	AFADJ	I	Test mode input. All test operation will be activate by "L" mode when power on.
67	LODIN	O	Output for turn the loading motor to loading.
68	LODOUT	O	Output for turn the loading motor to unloading.
69	LED	O	Output for motor volume LED lighting.
70	—	—	Not used (open).
71	Vss	—	Ground.
72	XTAL	O	Clock output.
73	+5V	—	+5V
74	EXTAL	I	Clock input. (4MHz)
75	+5V	—	+5V
76	-30V	I	Power voltage -30V for built in FL tube controller.
77	—	O	Not used (open).
78	—	O	Not used (open).
79	VDL DOWN	O	Output for motor volume down.
80	VOL UP	O	Output for motor volume up.

• IC Block Diagrams

IC101 CXA1372Q

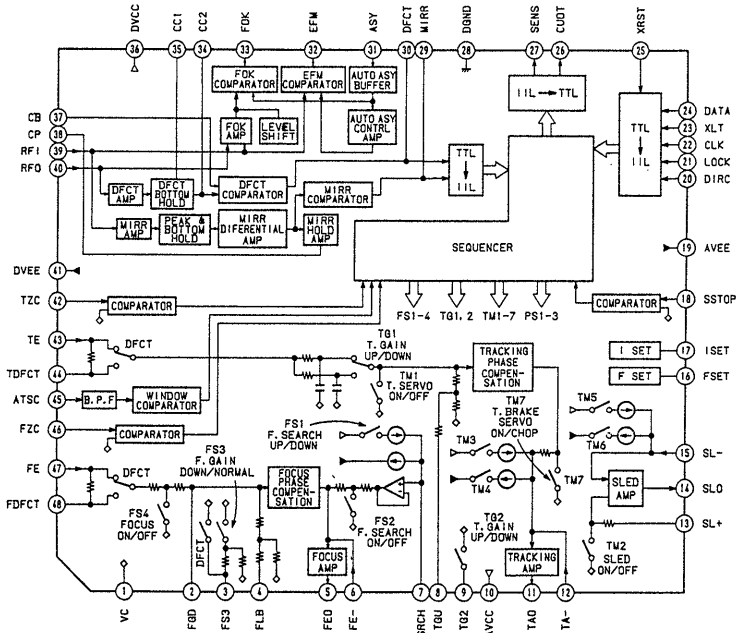

IC202 M5290P-16

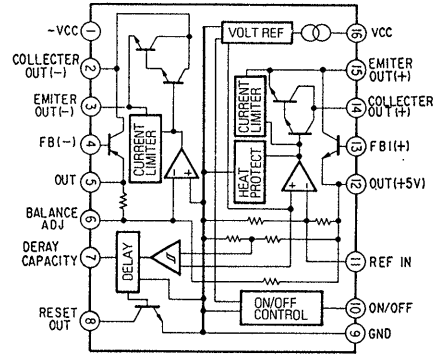

IC103 M54641L

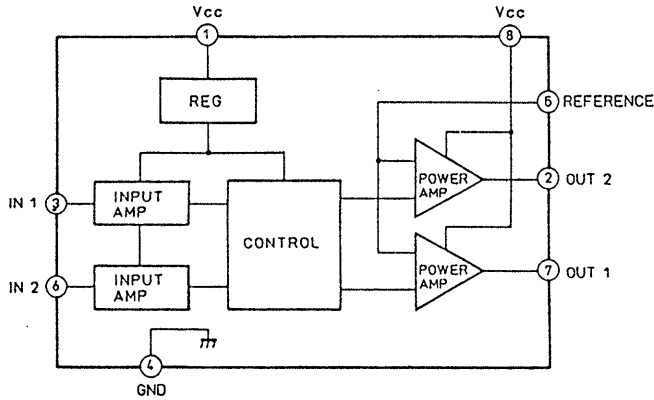

IC301 CXD2500AQ

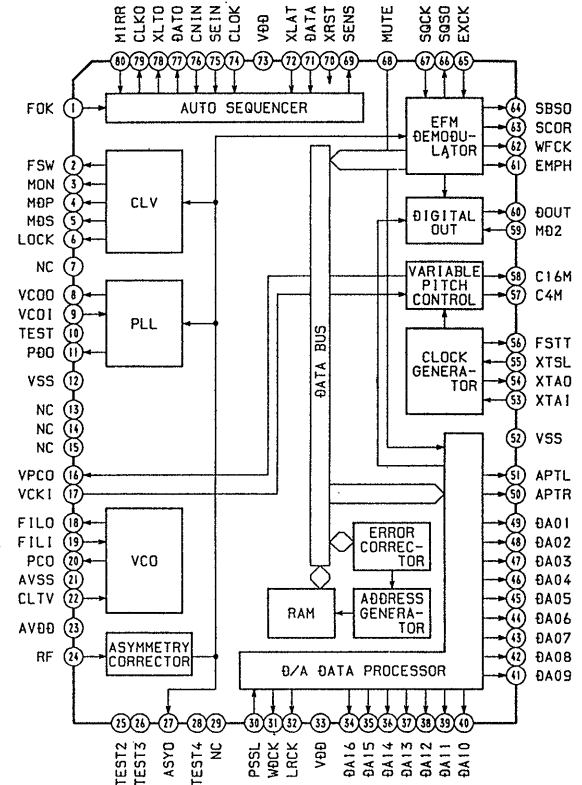

IC201 M5293L

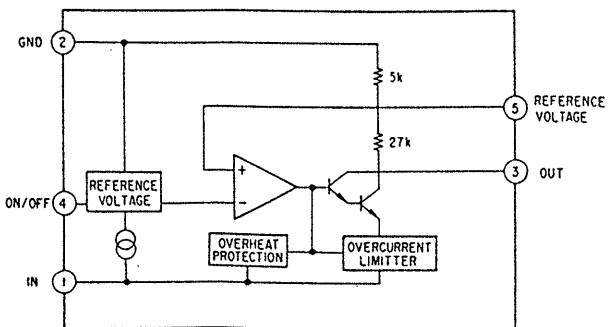

IC302 CXD1244S

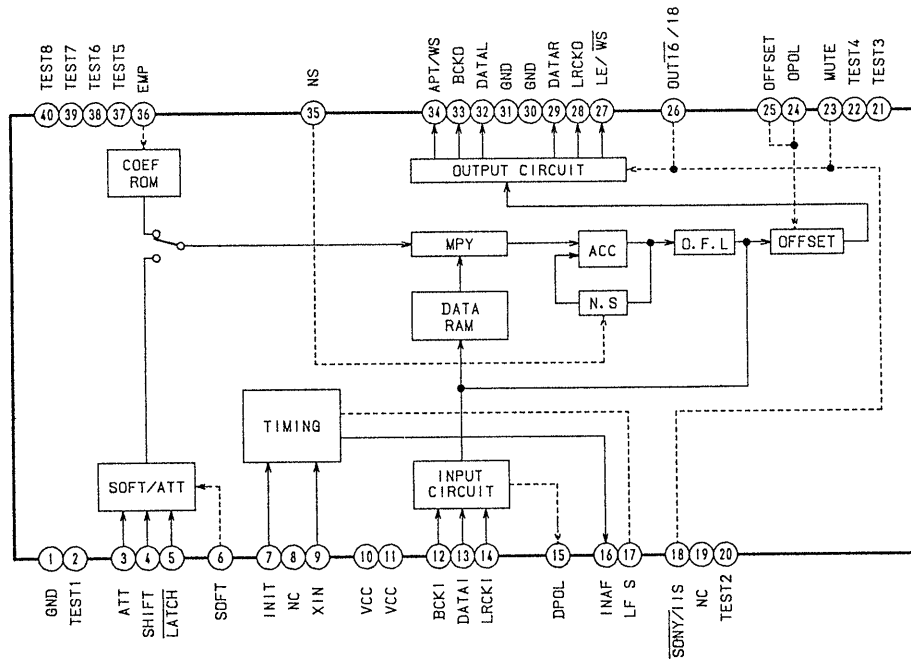

IC305 CXD2552Q

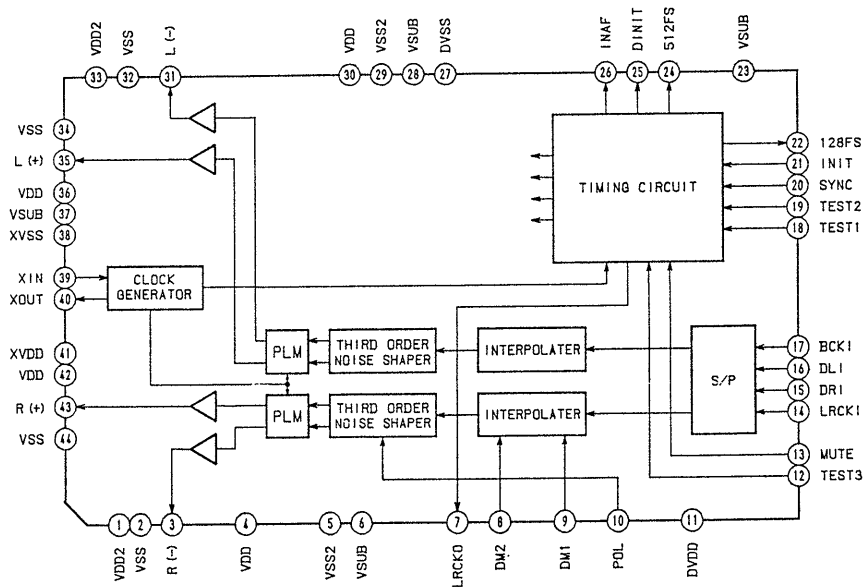

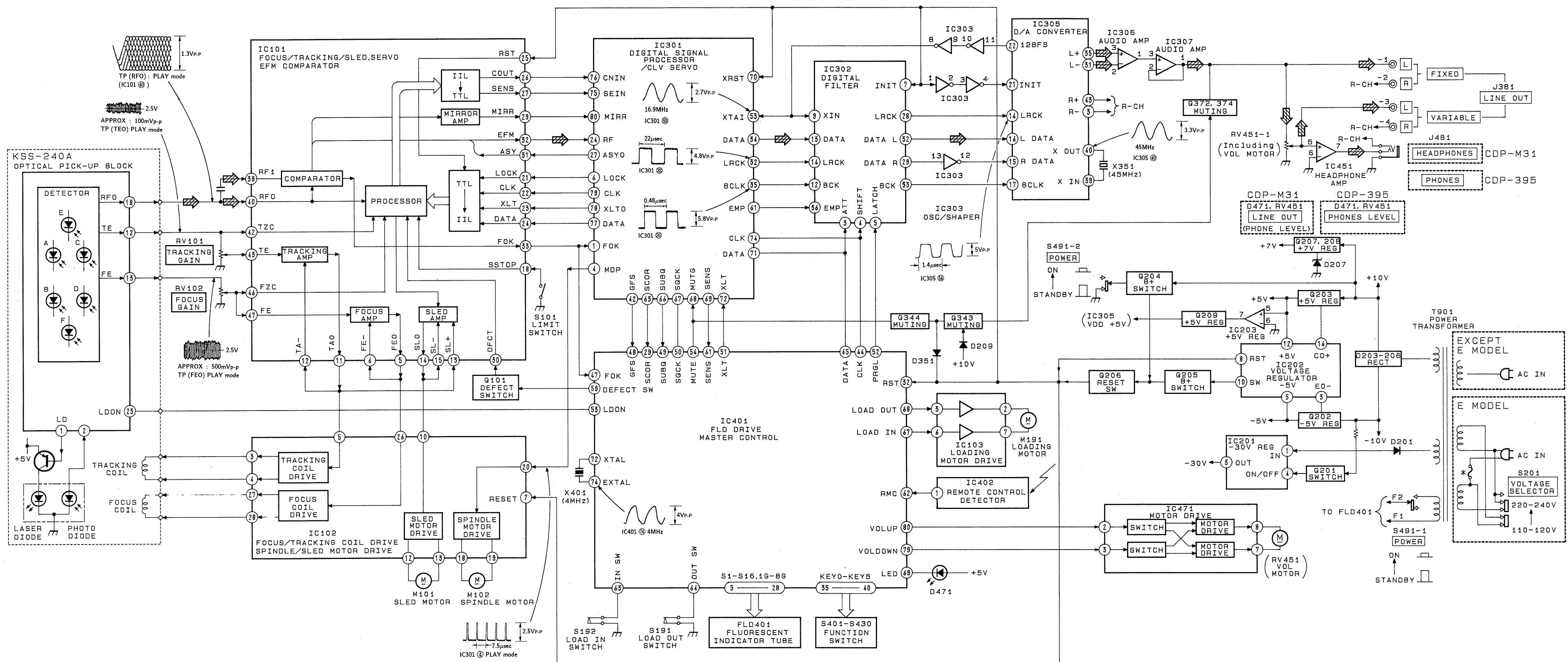

• Semiconductor Lead Layouts

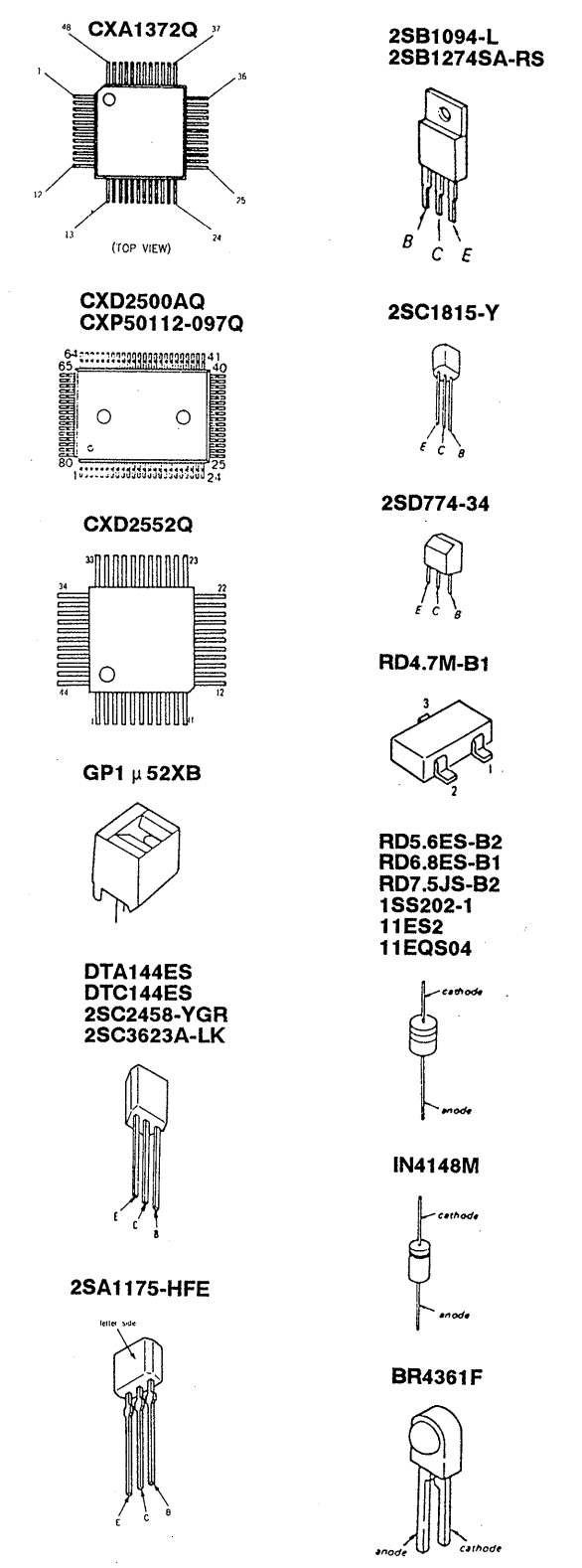

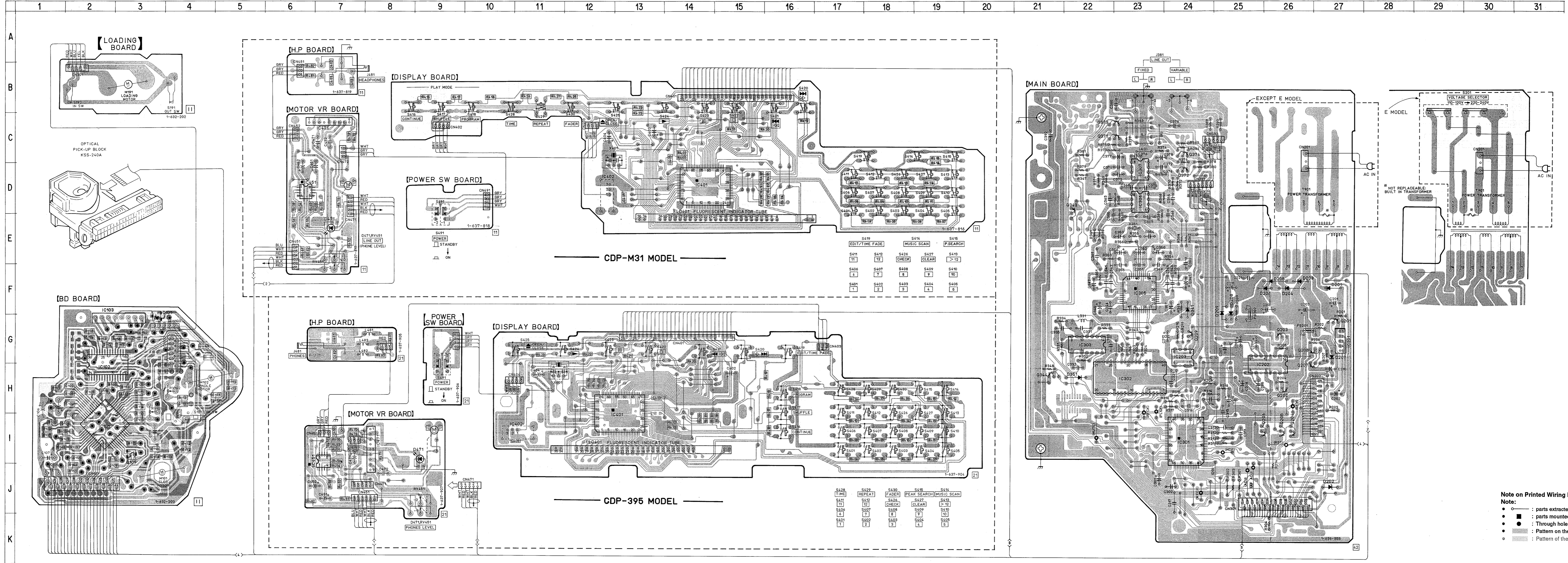

CDP-M31 MODEL

CDP-395 MODEL

MAIN BOARD

S419		S414		S415	
EDIT	TIME FADE	MUSIC	SCAN	P	SEARCH
S411	S412	S426	S427	S419	
1	2	CHECK	CLEAR	> 12	
S406	S407	S408	S409	S410	
6	7	8	9	10	
S401	S402	S403	S404	S405	
1	2	3	4	5	

S428		S422		S430		S415		S414	
TIME	REPEAT	FADER	PEAK SEARCH	MUSIC	SCAN				
S411	S412	S426	S427	S419					
1	2	CHECK	CLEAR	> 12					
S406	S407	S408	S409	S410					
6	7	8	9	10					
S401	S402	S403	S404	S405					
1	2	3	4	5					

Note on Printed Wiring Board:
Note:
 ○ — parts extracted from the component side.
 ● — parts mounted on the conductor side.
 ● — Through hole.
 ■ — Pattern on the side which is seen.
 ○ — Pattern of the rear side.

1 2 3 4 5 6 7 8 9 10 11 12 13 14 15 16 17 18 19 20 21 22 23 24 25 26 27 28

WAVEFORMS

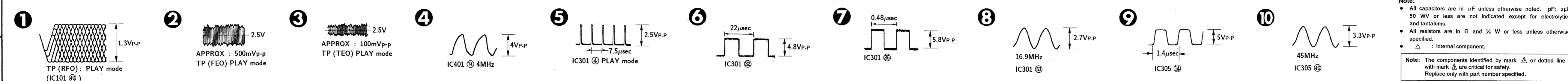

Note on Schematic Diagram:
Note:
 • All capacitors are in µF unless otherwise noted. pF: pF
 • All resistors are in Ω and ¼ W or less unless otherwise specified.
 • Δ: internal component.
Note: The components identified by mark Δ or dotted line with mark Δ are critical for safety. Replace only with part number specified.
 ○: B + Line.
 ⊖: B - Line.
 ⊕: adjustment for repair.
 ○: Voltages and waveforms are dc with respect to ground under no-signal (detuned) conditions.
 no mark: STOP
 ○: Voltages are taken with a VOM (10 MΩ/V). Voltage variations may be noted due to normal production tolerances.
 ○: Waveforms are taken with an oscilloscope. Voltage variations may be noted due to normal production tolerances.
 ○: Circled numbers refer to waveforms.
 ⊕: signal path.
 ⊕: CD

• Semiconductor Location

Ref. No.	Location
D101	G-3
D201	F-27
D202	J-27
D203	F-26
D204	F-26
D205	F-26
D206	F-26
D207	G-27
D208	F-26
D209	F-26
D341	F-24
D351	H-21
D471	E-7 (M31)
D471	I-9 (395)
IC101	I-2
IC102	H-2
IC103	G-3
IC201	G-27
IC202	H-26
IC203	G-24
IC301	I-24
IC302	H-23
IC303	H-22
IC305	F-23
IC306	D-23
IC307	D-23
IC401	D-14 (M31)
IC401	I-13 (395)
IC402	D-12 (M31)
IC402	I-10 (395)
IC451	D-6 (M31)
IC451	I-7 (395)
IC471	C-7 (M31)
IC471	I-8 (395)
O101	I-3
O201	G-27
O202	H-26
O203	G-26
O204	I-26
O205	I-26
O206	I-25
O207	H-26
O208	G-26
O209	G-24
O343	D-22
O344	I-21
O371	C-22
O372	D-24
O373	C-22
Q374	O-24

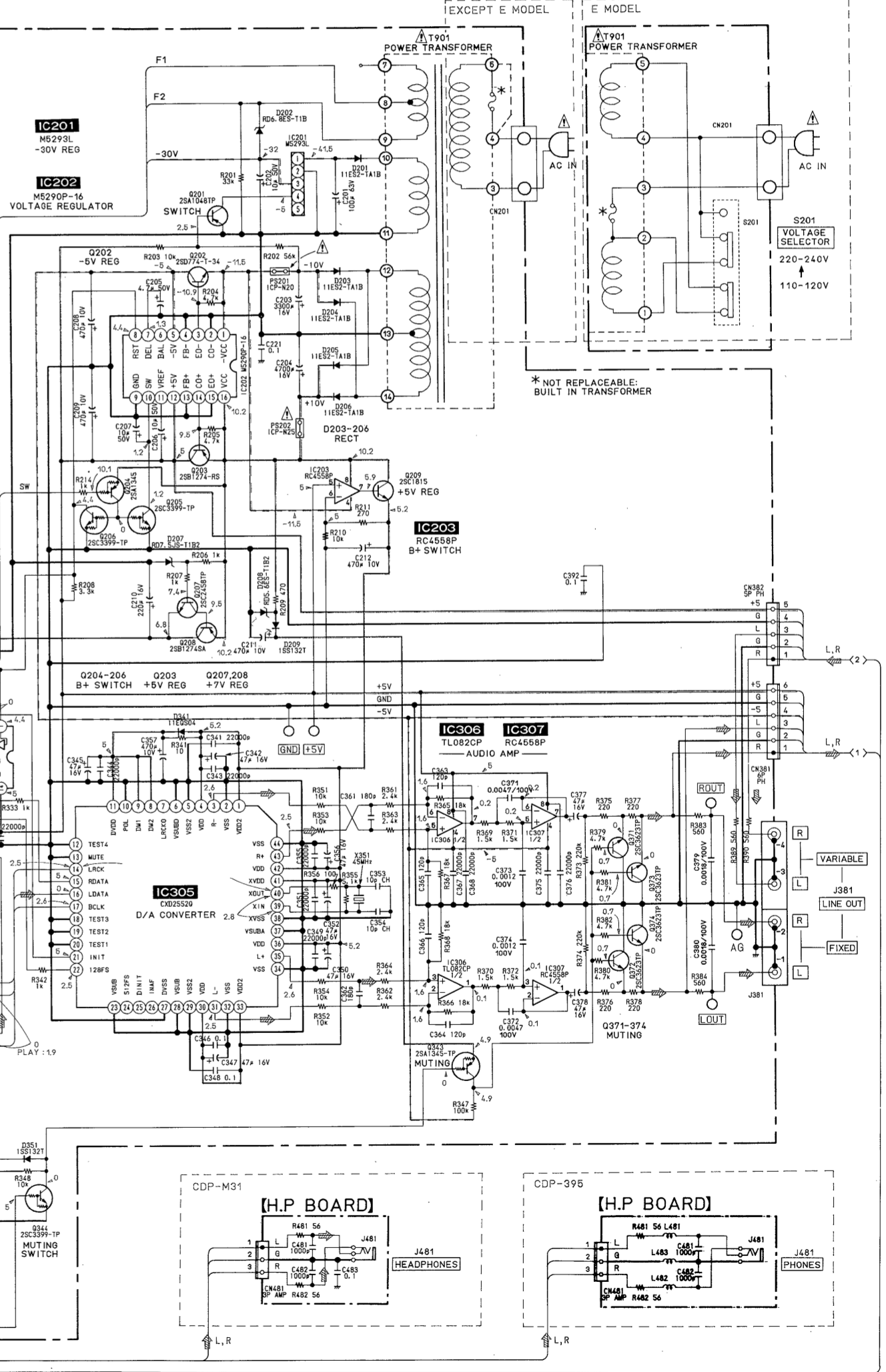
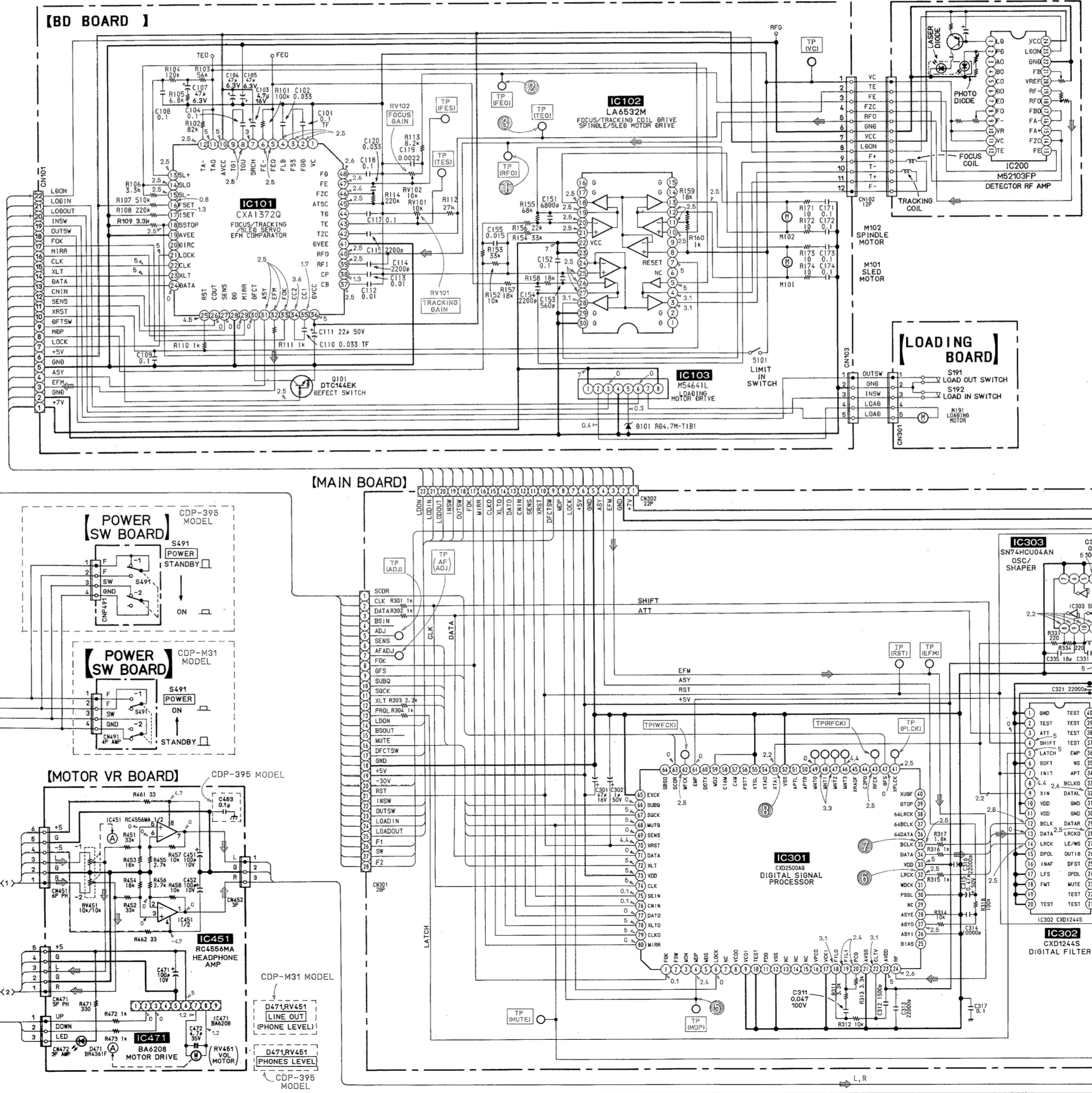
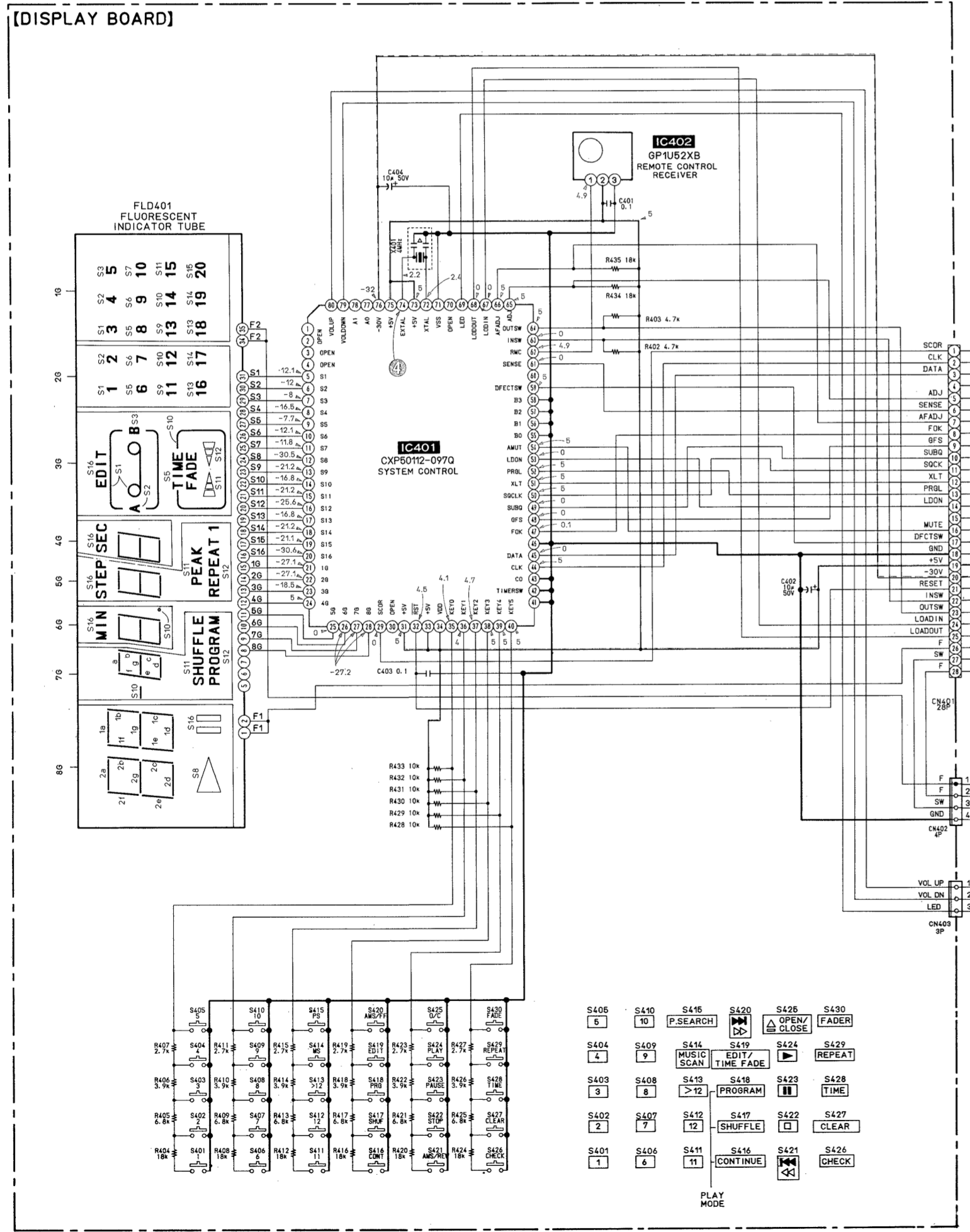

SECTION 6 EXPLODED VIEWS

NOTE:

- -XX and -X mean standardized parts, so they may have some differences from the original one.
- Color Indication of Appearance Parts
Example:
KNOB, BALANCE (WHITE) . . . (RED)

↑ ↑
Parts Color Cabinet's Color

- Items marked "*" are not stocked since they are seldom required for routine service. Some delay should be anticipated when ordering these items.
- The mechanical parts with no reference number in the exploded views are not supplied.
- Hardware (# mark) list is given in the last of this parts list.

The components identified by mark or dotted line with mark are critical for safety. Replace only with part number specified.

(1) CABINET SECTION (CDP-M31)

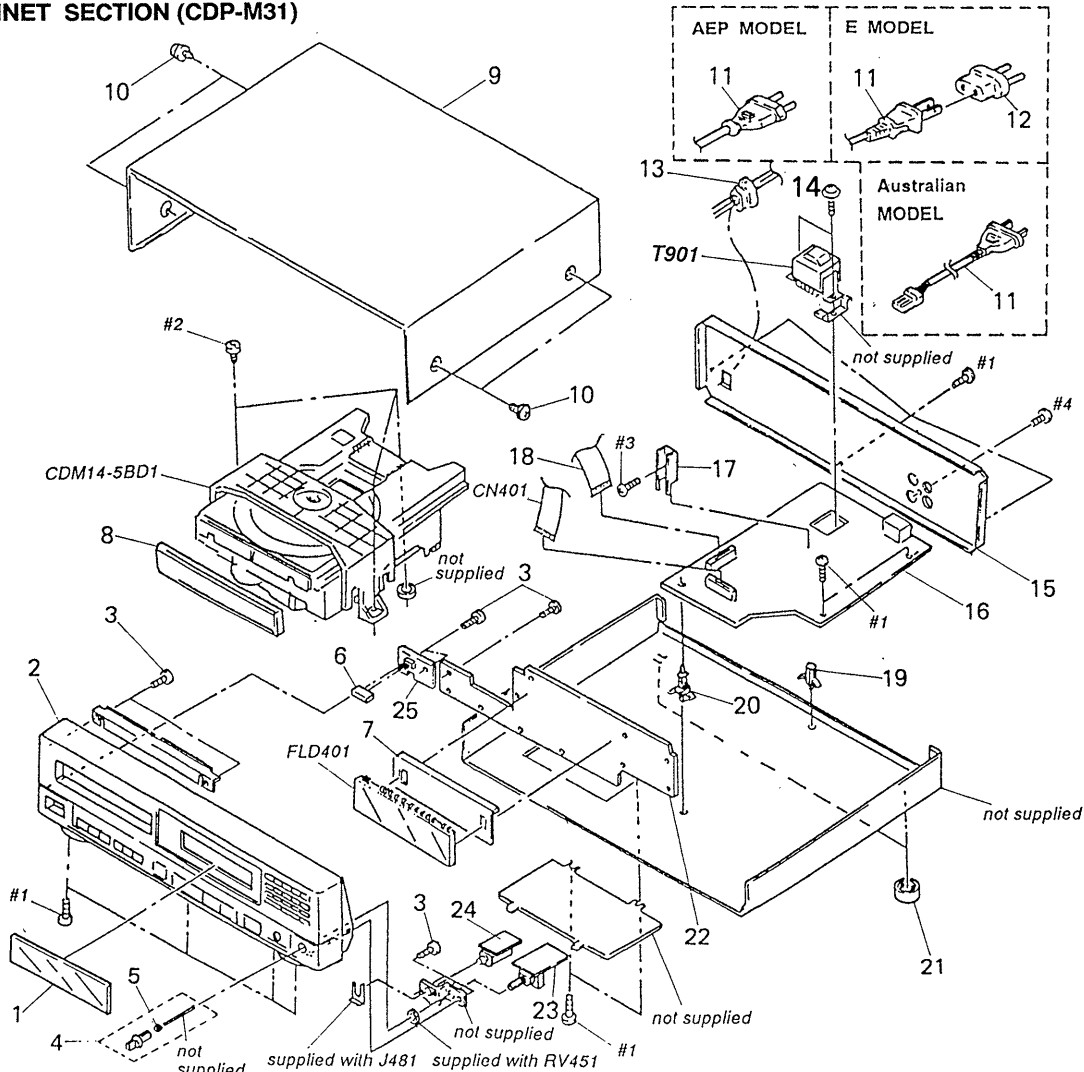

Ref. No.	Part No.	Description	Remark	Ref. No.	Part No.	Description	Remark
1	4-942-977-01	PLATE, INDICATION		16	* A-4617-688-A	MAIN BOARD, COMPLETE (MADE IN FRANCE M31)	
1	4-942-983-01	PLATE, INDICATION (TYPE-B) (M31:E, Australian)		16	* A-4617-701-A	MAIN BOARD, COMPLETE (MADE IN JAPAN M31:AEP, Australian)	
2	X-4941-317-1	PANEL ASSY, FRONT (M31:AEP)		16	* A-4617-703-A	MAIN BOARD, COMPLETE (MADE IN JAPAN M31:E)	
2	X-4941-323-1	PANEL ASSY, FRONT (M31:E, Australian)		17	4-902-345-01	HEAT SINK	
3	4-928-635-01	SCREW, +BV (2.6X8) TAPPING		18	1-575-160-11	WIRE, FLAT TYPE (22 CORE)	
4	A-4604-727-A	KNOB (HP) ASSY		19	* 3-349-025-41	HOLDER, PC BOARD	
5	4-922-979-01	INDICATOR		20	* 4-924-098-31	HOLDER, PC BOARD	
6	4-927-341-01	BUTTON (POWER) (M31)		21	4-933-601-01	FOOT	
7	* 4-923-103-01	HOLDER, FL TUBE (M31)		22	* A-4617-686-A	DISPLAY BOARD, COMPLETE (MADE IN FRANCE M31)	
8	4-942-979-01	PANEL, LOADING (M31:AEP)		22	* A-4617-774-A	DISPLAY BOARD, COMPLETE (MADE IN JAPAN M31:AEP)	
8	4-942-979-41	PANEL, LOADING (M31:E, Australian)		23	* 1-637-817-11	MOTOR VR BOARD (MADE IN JAPAN M31)	
9	4-919-376-31	CASE		23	* 1-637-817-21	MOTOR VR BOARD (MADE IN FRANCE M31)	
10	3-704-366-01	SCREW (CASE) (M3X8)		24	* 1-637-819-11	HP BOARD (MADE IN JAPAN M31)	
11	1-574-127-31	CORD, POWER (MADE IN FRANCE:AEP)		24	* 1-637-819-21	HP BOARD (MADE IN FRANCE M31)	
11	1-574-358-31	CORD, POWER (WITH CONNECTOR) (Australian)		25	* 1-637-818-11	POWER SW BOARD (MADE IN JAPAN M31)	
11	1-575-651-21	CORD, POWER (MADE IN JAPAN:AEP)		25	* 1-637-818-21	POWER SW BOARD (MADE IN FRANCE M31)	
11	1-575-653-21	CORD, POWER (E)		CN401	1-535-883-11	JUMPER, FILM (WITH TERMINAL)	
12	1-569-007-11	ADAPTOR, CONVERSION 2P (M31:E)		FLD401	1-519-611-11	INDICATOR TUBE, FLUORESCENT	
13	* 3-703-244-00	BUSHING (2104), CORD		T901	1-449-922-11	TRANSFORMER, POWER (MADE IN JAPAN M31:AEP, Australian)	
14	4-886-821-11	SCREW, S TIGHT, +PTTWH 3X6		T901	1-449-923-11	TRANSFORMER, POWER (M31:E)	
15	4-941-552-21	PANEL (ALSACE), BACK (MADE IN FRANCE M31)		T901	1-449-925-11	TRANSFORMER, POWER (MADE IN FRANCE M31:AEP)	
15	* 4-942-980-01	PANEL, BACK (MADE IN JAPAN M31:AEP)					
15	* 4-942-980-11	PANEL, BACK (MADE IN JAPAN M31:Australian)					
15	* 4-942-980-21	PANEL, BACK (MADE IN JAPAN M31:E)					

(2) CABINET SECTION (CDP-395)

Note: The components identified by mark \triangle or dotted line with mark \triangle are critical for safety. Replace only with part number specified.

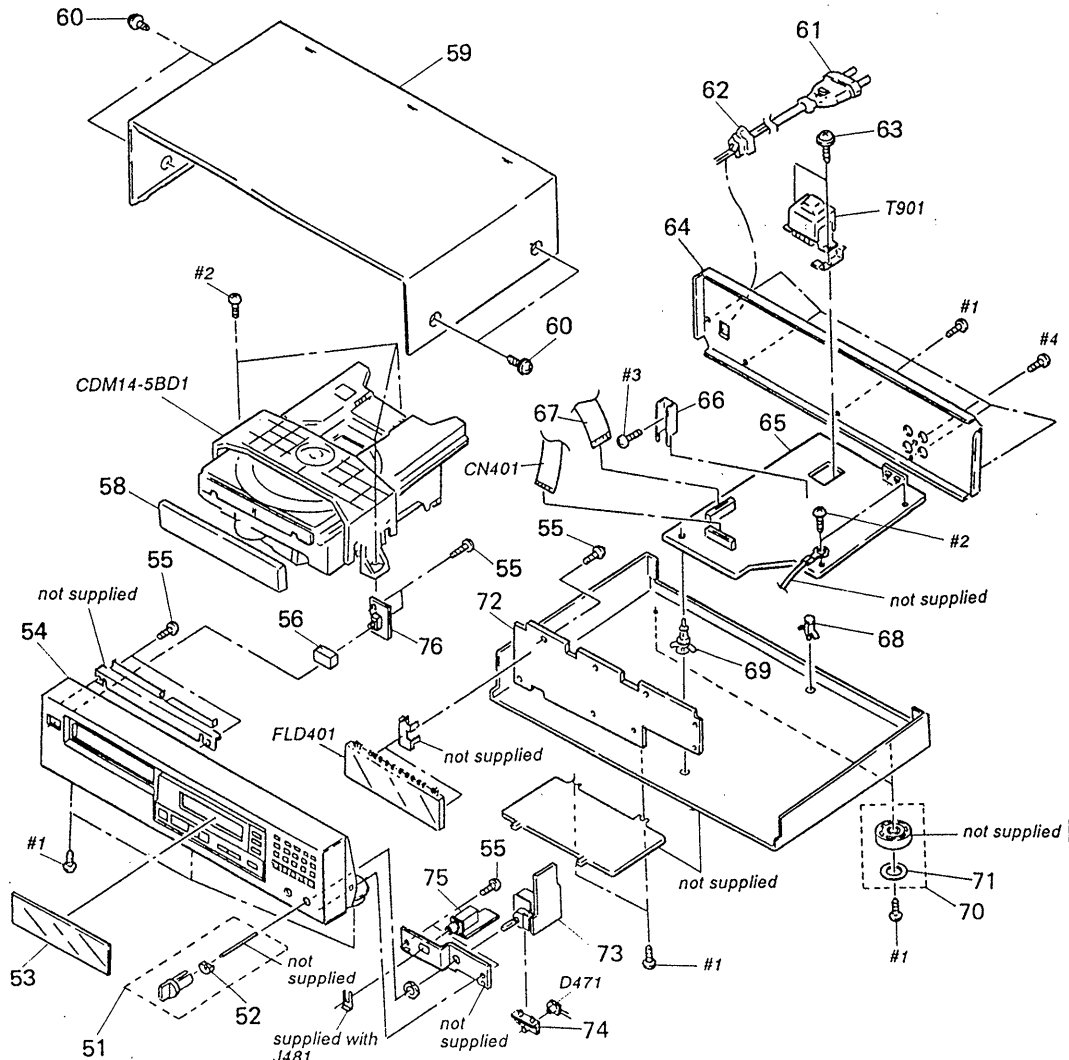

Ref. No.	Part No.	Description	Remark
51	A-4604-727-A	KNOB (HP) ASSY	
52	4-922-979-01	INDICATOR	
53	4-942-767-01	PLATE, INDICATION (395)	
54	X-4941-256-1	PANEL ASSY, FRONT (MADE IN JAPAN 395:AEP)	
54	X-4941-257-1	PANEL ASSY, FRONT (MADE IN FRANCE 395:AEP)	
55	4-928-635-01	SCREW, +BV (2.6X8) TAPPING	
56	4-922-921-02	BUTTON (POWER) (395)	
58	4-942-763-01	PANEL, LOADING (MADE IN JAPAN 395:AEP)	
58	4-942-763-11	PANEL, LOADING (MADE IN FRANCE 395)	
59	4-929-035-31	CASE (MADE IN JAPAN 395)	
59	4-929-035-41	CASE (MADE IN FRANCE 395)	
60	3-704-366-01	SCREW (CASE) (M3X8)	
61	1-574-127-31	CORD, POWER (MADE IN FRANCE 395:AEP)	
61	1-575-651-21	CORD, POWER (MADE IN JAPAN 395:AEP)	
62	* 3-703-244-00	BUSHING (2104), CORD	
63	4-886-821-11	SCREW, S TIGHT, +PTTWH 3X6	
64	4-942-768-21	PANEL, BACK (MADE IN JAPAN 395:AEP)	
64	4-942-768-51	PANEL (ALSACE), BACK (MADE IN FRANCE 395:AEP)	
65	* A-4617-688-A	MAIN BOARD, COMPLETE (MADE IN FRANCE 395:AEP)	
65	* A-4617-701-A	MAIN BOARD, COMPLETE (MADE IN JAPAN 395)	

Ref. No.	Part No.	Description	Remark
66	4-902-345-01	HEAT SINK	
67	1-575-160-11	WIRE, FLAT TYPE (22 CORE)	
68	* 3-349-025-41	HOLDER, PC BOARD	
69	* 4-924-098-31	HOLDER, PC BOARD	
70	X-3304-938-2	FOOT, ASSY (395)	
71	4-923-836-11	CUSHION (395)	
72	* A-4617-700-A	DISPLAY BOARD, COMPLETE (MADE IN JAPAN 395:AEP)	
72	* A-4617-709-A	DISPLAY BOARD, COMPLETE (MADE IN FRANCE 395:AEP)	
73	* 1-637-907-11	MOTOR VR BOARD (MADE IN JAPAN 395:AEP)	
73	1-637-907-21	MOTOR VR BOARD (MADE IN FRANCE 395:AEP)	
74	* 4-922-980-01	HOLDER LED (395)	
75	* 1-637-905-11	HP BOARD (MADE IN JAPAN 395:AEP)	
75	* 1-637-905-21	HP BOARD (MADE IN FRANCE 395:AEP)	
76	* 1-637-906-11	POWER SW BOARD (MADE IN JAPAN 395:AEP)	
76	* 1-637-906-21	POWER SW BOARD (MADE IN FRANCE 395:AEP)	
CN401	1-535-883-11	JUMPER, FILM (WITH TERMINAL)	
T901	1-449-922-11	TRANSFORMER, POWER (MADE IN JAPAN 395:AEP)	
T901	1-449-925-11	TRANSFORMER, POWER (MADE IN FRANCE 395:AEP)	

(3) MD SECTION (CDM14-5BD1)

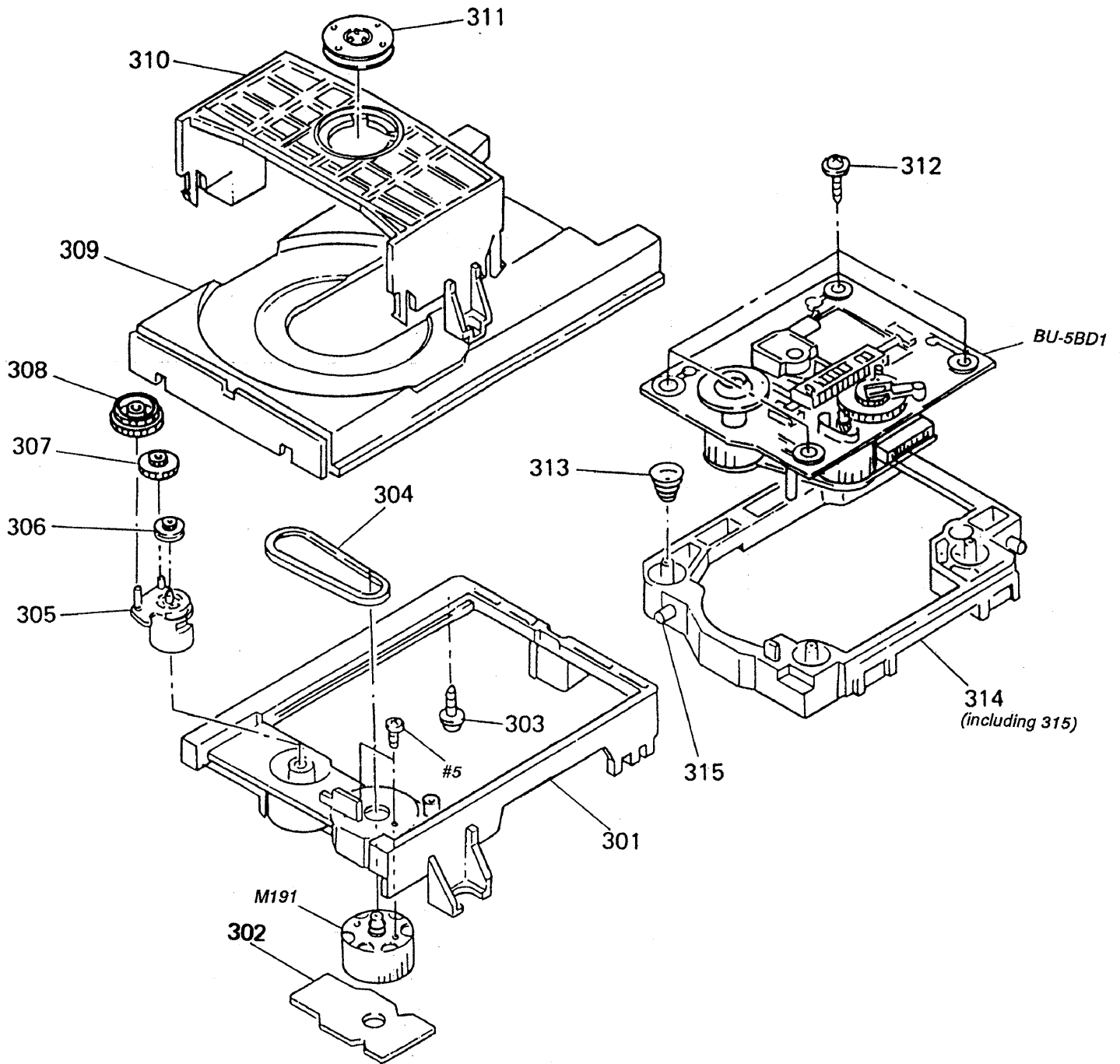

Ref. No.	Part No.	Description	Remark
301	4-933-111-01	CHASSIS (MD)	
302	* 1-632-202-11	LOADING BOARD (MADE IN JAPAN)	
302	* 1-632-202-21	LOADING BOARD (MADE IN FRANDE)	
303	* 4-917-583-21	BRACKET, YOKE	
304	4-927-649-01	BELT	
305	4-933-109-01	CAM	
306	4-927-651-01	PULLEY (S)	
307	4-927-628-01	GEAR (C)	

Ref. No.	Part No.	Description	Remark
308	4-933-107-01	GEAR (PL)	
309	4-933-112-01	TABLE, DISK	
310	4-933-110-01	HOLDER (MG)	
311	* 1-452-538-11	MAGNET	
312	4-933-134-01	SCREW +PTPWH M2. 6X6	
313	4-917-541-01	SPRING (B)	
314	4-933-129-01	HOLDER (BU)	315
315	4-933-108-01	SHAFT (CAM)	
M191	A-4604-363-A	MOTOR (L) ASSY (LOADING)	

(4) PICK-UP BLOCK (BU-5BD1)

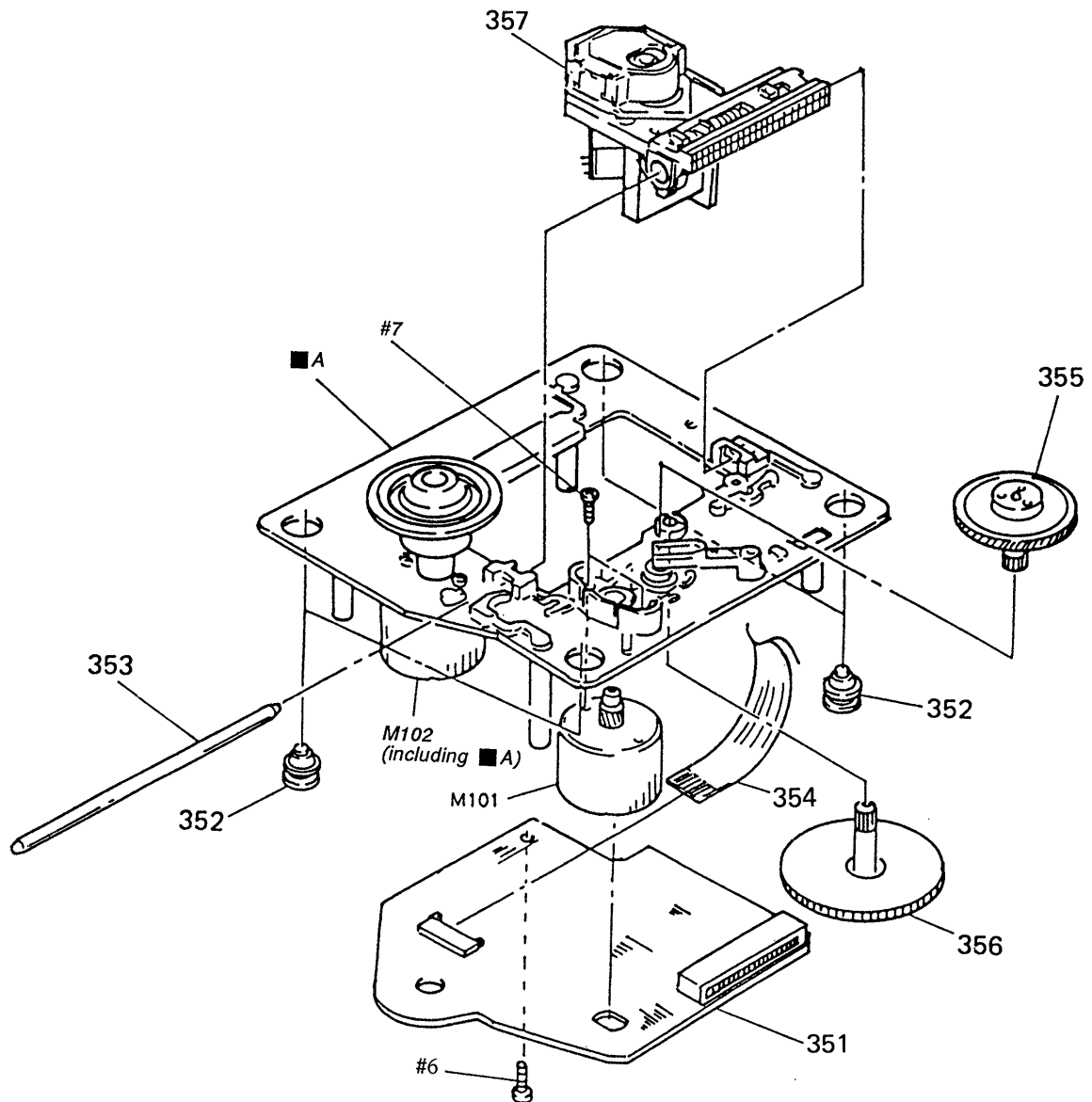

Ref. No.	Part No.	Description	Remark
351	A-4617-161-A	BD BOARD, COMPLETE	
352	4-933-126-01	INSULATOR (A)	
353	4-917-565-01	SHAFT, SLED	
354	1-575-001-11	WIRE, FLAT TYPE (12 CORE)	
355	4-917-567-01	GEAR (M)	
356	4-917-564-01	GEAR (P), FLATNESS	
357	△ 8-848-144-11	DEVICE, OPTICAL KSS-240A	
M101	X-4917-504-1	MOTOR, ASSY (SLED)	
M102	X-4917-523-3	MOTOR, ASSY (SPINDLE)	

Note: The components identified by mark △ or dotted line with mark △ are critical for safety. Replace only with part number specified.

SECTION 7
ELECTRICAL PARTS LIST

BD

NOTE:

- Due to standardization, replacements in the parts list may be different from the parts specified in the diagrams or the components used on the set.
- -XX and -X mean standardized parts, so they may have some differences from the original one.
- RESISTORS
All resistors are in ohms.
METAL: Metal-film resistor
METAL OXIDE: Metal Oxide-film resistor
F: nonflammable.

- Items marked "*" are not stocked since they are seldom required for routine service. Some delay should be anticipated when ordering these items.
- SEMICONDUCTORS
In each case, u: μ , for example:
uA...: μ A..., uPA...: μ PA...,
uPB...: μ PB..., uPC...: μ PC...,
uPD...: μ PD...
- CAPACITORS
uF: μ F
- COILS
uH: μ H

The components identified by mark Δ or dotted line with mark Δ are critical for safety. Replace only with part number specified.

When including parts by reference number, please include the board name.

Ref. No.	Part No.	Description	Remark	Ref. No.	Part No.	Description	Remark
	A-4617-161-A	BD BOARD, COMPLETE *****				< CONNECTOR >	
		< CAPACITOR >					
C101	1-163-038-00	CERAMIC CHIP	0.1uF 25V	CN101	1-568-796-11	SOCKET, CONNECTOR 22P	
C102	1-163-989-11	CERAMIC CHIP	0.033uF 10% 25V	CN102	1-568-795-11	SOCKET, CONNECTOR 12P	
C103	1-126-163-11	ELECT	4.7uF 20% 50V	CN103	* 1-564-721-11	PIN, CONNECTOR (SMALL TYPE) 5P	
C104	1-163-038-00	CERAMIC CHIP	0.1uF 25V			< DIODE >	
C105	1-126-154-11	ELECT	47uF 20% 6.3V	D101	8-719-105-72	DIODE RD4.7M-B1	
						< IC >	
C106	1-126-154-11	ELECT	47uF 20% 6.3V	IC101	8-752-050-82	IC SC CXA1372Q	
C107	1-126-154-11	ELECT	47uF 20% 6.3V	IC102	8-759-822-36	IC LA6532M	
C108	1-163-038-00	CERAMIC CHIP	0.1uF 25V	IC103	8-759-633-65	IC M54641L	
C109	1-163-038-00	CERAMIC CHIP	0.1uF 25V			< JUMPER >	
C110	1-163-989-11	CERAMIC CHIP	0.033uF 10% 25V	J101	1-216-295-00	METAL CHIP 0 5% 1/10W	
C111	1-131-367-00	TANTALUM	22uF 10% 20V	J102	1-216-295-00	METAL CHIP 0 5% 1/10W	
C112	1-164-232-11	CERAMIC CHIP	0.01uF 50V			< TRANSISTOR >	
C113	1-164-232-11	CERAMIC CHIP	0.01uF 50V	Q101	8-729-901-01	TRANSISTOR DTC144EK	
C114	1-164-161-11	CERAMIC CHIP	0.0022uF 10% 100V			< RESISTOR >	
C115	1-164-161-11	CERAMIC CHIP	0.0022uF 10% 100V	R101	1-216-097-00	METAL CHIP 100K 5% 1/10W	
C117	1-163-038-00	CERAMIC CHIP	0.1uF 25V	R102	1-216-095-00	METAL CHIP 82K 5% 1/10W	
C118	1-163-038-00	CERAMIC CHIP	0.1uF 25V	R103	1-216-091-00	METAL CHIP 56K 5% 1/10W	
C119	1-164-161-11	CERAMIC CHIP	0.0022uF 10% 100V	R104	1-216-099-00	METAL CHIP 120K 5% 1/10W	
C120	1-163-989-11	CERAMIC CHIP	0.033uF 10% 25V	R105	1-216-069-00	METAL CHIP 6.8K 5% 1/10W	
C151	1-163-019-00	CERAMIC CHIP	0.0068uF 10% 50V	R106	1-216-061-00	METAL CHIP 3.3K 5% 1/10W	
C152	1-163-038-00	CERAMIC CHIP	0.1uF 25V	R107	1-216-114-00	METAL GLAZE 510K 5% 1/10W	
C153	1-163-006-11	CERAMIC CHIP	560PF 10% 50V	R108	1-216-105-00	METAL CHIP 220K 5% 1/10W	
C154	1-164-161-11	CERAMIC CHIP	0.0022uF 10% 100V	R109	1-216-061-00	METAL CHIP 3.3K 5% 1/10W	
C155	1-163-023-00	CERAMIC CHIP	0.015uF 5% 50V	R110	1-216-049-00	METAL CHIP 1K 5% 1/10W	
C171	1-163-038-00	CERAMIC CHIP	0.1uF 25V				
C172	1-163-038-00	CERAMIC CHIP	0.1uF 25V				
C173	1-163-038-00	CERAMIC CHIP	0.1uF 25V				
C174	1-163-038-00	CERAMIC CHIP	0.1uF 25V				

BD **DISPLAY**

Ref. No.	Part No.	Description	Remark
R111	1-216-049-00	METAL CHIP 1K	5% 1/10W
R112	1-216-083-00	METAL CHIP 27K	5% 1/10W
R113	1-216-071-00	METAL CHIP 8.2K	5% 1/10W
R114	1-216-105-00	METAL CHIP 220K	5% 1/10W
R152	1-216-073-00	METAL CHIP 10K	5% 1/10W
R153	1-216-085-00	METAL CHIP 33K	5% 1/10W
R154	1-216-085-00	METAL CHIP 33K	5% 1/10W
R155	1-216-093-00	METAL CHIP 68K	5% 1/10W
R156	1-216-081-00	METAL CHIP 22K	5% 1/10W
R157	1-216-079-00	METAL CHIP 18K	5% 1/10W
R158	1-216-079-00	METAL CHIP 18K	5% 1/10W
R159	1-216-079-00	METAL CHIP 18K	5% 1/10W
R160	1-216-049-00	METAL CHIP 1K	5% 1/10W
R171	1-216-001-00	METAL CHIP 10	5% 1/10W
R172	1-216-001-00	METAL CHIP 10	5% 1/10W
R173	1-216-001-00	METAL CHIP 10	5% 1/10W
R174	1-216-001-00	METAL CHIP 10	5% 1/10W
< VARIABLE RESISTOR >			
RV101	1-238-016-11	RES. ADJ. CARBON 10K (TRACKING GAIN)	
RV102	1-238-016-11	RES. ADJ. CARBON 10K (FOCUS GAIN)	
< SWITCH >			
S101	1-572-085-11	SWITCH, LEAF (LIMIT IN)	

* A-4617-686-A DISPLAY BOARD, COMPLETE (MADE IN FRANCE M31)			
* A-4617-700-A DISPLAY BOARD, COMPLETE (MADE IN JAPAN 395)			
* A-4617-709-A DISPLAY BOARD, COMPLETE (MADE IN FRANCE 395)			
* A-4617-774-A DISPLAY BOARD, COMPLETE (MADE IN JAPAN M31)			

* 4-923-103-01 HOLDER, FL TUBE			
< CAPACITOR >			
C401	1-163-038-00	CERAMIC CHIP 0.1uF	25V
C402	1-124-261-00	ELECT 10uF	20% 50V
C403	1-163-038-00	CERAMIC CHIP 0.1uF	25V
C404	1-124-261-00	ELECT 10uF	20% 50V
< CONNECTOR >			
CN401	1-535-883-11	JUMPER, FILM (WITH TERMINAL) (M31)	
< FLUORESCENT INDICATOR >			
FLD401	1-519-611-11	INDICATOR TUBE, FLUORESCENT	

Ref. No.	Part No.	Description	Remark
< IC >			
IC401	8-752-817-41	IC CXP50112-097Q	
IC402	8-749-920-83	IC GP1U52XB	
< RESISTOR >			
R402	1-216-065-00	METAL CHIP 4.7K	5% 1/10W
R403	1-216-065-00	METAL CHIP 4.7K	5% 1/10W
R404	1-216-079-00	METAL CHIP 18K	5% 1/10W
R405	1-216-069-00	METAL CHIP 6.8K	5% 1/10W
R406	1-216-063-00	METAL CHIP 3.9K	5% 1/10W
R407	1-216-059-00	METAL CHIP 2.7K	5% 1/10W
R408	1-216-079-00	METAL CHIP 18K	5% 1/10W
R409	1-216-069-00	METAL CHIP 6.8K	5% 1/10W
R410	1-216-063-00	METAL CHIP 3.9K	5% 1/10W
R411	1-216-059-00	METAL CHIP 2.7K	5% 1/10W
R412	1-216-079-00	METAL CHIP 18K	5% 1/10W
R413	1-216-069-00	METAL CHIP 6.8K	5% 1/10W
R414	1-216-063-00	METAL CHIP 3.9K	5% 1/10W
R415	1-216-059-00	METAL CHIP 2.7K	5% 1/10W
R416	1-216-079-00	METAL CHIP 18K	5% 1/10W
R417	1-216-069-00	METAL CHIP 6.8K	5% 1/10W
R418	1-216-063-00	METAL CHIP 3.9K	5% 1/10W
R419	1-216-059-00	METAL CHIP 2.7K	5% 1/10W
R420	1-216-079-00	METAL CHIP 18K	5% 1/10W
R421	1-216-069-00	METAL CHIP 6.8K	5% 1/10W
R422	1-216-063-00	METAL CHIP 3.9K	5% 1/10W
R423	1-216-059-00	METAL CHIP 2.7K	5% 1/10W
R424	1-216-079-00	METAL CHIP 18K	5% 1/10W
R425	1-216-069-00	METAL CHIP 6.8K	5% 1/10W
R426	1-216-063-00	METAL CHIP 3.9K	5% 1/10W
R427	1-216-059-00	METAL CHIP 2.7K	5% 1/10W
R428	1-216-073-00	METAL CHIP 10K	5% 1/10W
R429	1-216-073-00	METAL CHIP 10K	5% 1/10W
R430	1-216-073-00	METAL CHIP 10K	5% 1/10W
R431	1-216-073-00	METAL CHIP 10K	5% 1/10W
R432	1-216-073-00	METAL CHIP 10K	5% 1/10W
R433	1-216-073-00	METAL CHIP 10K	5% 1/10W
R434	1-216-079-00	METAL CHIP 18K	5% 1/10W
R435	1-216-079-00	METAL CHIP 18K	5% 1/10W
< SWITCH > (MADE IN JAPAN)			
S401	1-554-303-52	SWITCH, KEY BOARD (1)	
S402	1-554-303-52	SWITCH, KEY BOARD (2)	
S403	1-554-303-52	SWITCH, KEY BOARD (3)	
S404	1-554-303-52	SWITCH, KEY BOARD (4)	
S405	1-554-303-52	SWITCH, KEY BOARD (5)	

DISPLAY **HP** **LOADING**

Ref. No.	Part No.	Description	Remark
S406	1-554-303-52	SWITCH, KEY BOARD (6)	
S407	1-554-303-52	SWITCH, KEY BOARD (7)	
S408	1-554-303-52	SWITCH, KEY BOARD (8)	
S409	1-554-303-52	SWITCH, KEY BOARD (9)	
S410	1-554-303-52	SWITCH, KEY BOARD (10)	
S411	1-554-303-52	SWITCH, KEY BOARD (11)	
S412	1-554-303-52	SWITCH, KEY BOARD (12)	
S413	1-554-303-52	SWITCH, KEY BOARD (>12)	
S414	1-554-303-52	SWITCH, KEY BOARD (MUSIC SCAN)	
S415	1-554-303-52	SWITCH, KEY BOARD (P. SEARCH)	
S416	1-554-303-52	SWITCH, KEY BOARD (CONTINUE)	
S417	1-554-303-52	SWITCH, KEY BOARD (SHUFFLE)	
S418	1-554-303-52	SWITCH, KEY BOARD (PROGRAM)	
S419	1-554-303-52	SWITCH, KEY BOARD (EDIT/TIME FADE)	
S420	1-554-303-52	SWITCH, KEY BOARD (▶▶ ▷▷)	
S421	1-554-303-52	SWITCH, KEY BOARD (◀◀ ◀◀)	
S422	1-554-303-52	SWITCH, KEY BOARD (□)	
S423	1-554-303-52	SWITCH, KEY BOARD (▣)	
S424	1-554-303-52	SWITCH, KEY BOARD (▶)	
S425	1-554-303-52	SWITCH, KEY BOARD (△OPEN/CLOSE)	
S426	1-554-303-52	SWITCH, KEY BOARD (CHECK)	
S427	1-554-303-52	SWITCH, KEY BOARD (CLEAR)	
S428	1-554-303-52	SWITCH, KEY BOARD (TIME)	
S429	1-554-303-52	SWITCH, KEY BOARD (REPEAT)	
S430	1-554-303-52	SWITCH, KEY BOARD (FADER)	
< SWITCH > (MADE IN FRANCE)			
S401	1-554-303-81	SWITCH, KEY BOARD (1)	
S402	1-554-303-81	SWITCH, KEY BOARD (2)	
S403	1-554-303-81	SWITCH, KEY BOARD (3)	
S404	1-554-303-81	SWITCH, KEY BOARD (4)	
S405	1-554-303-81	SWITCH, KEY BOARD (5)	
S406	1-554-303-81	SWITCH, KEY BOARD (6)	
S407	1-554-303-81	SWITCH, KEY BOARD (7)	
S408	1-554-303-81	SWITCH, KEY BOARD (8)	
S409	1-554-303-81	SWITCH, KEY BOARD (9)	
S410	1-554-303-81	SWITCH, KEY BOARD (10)	
S411	1-554-303-81	SWITCH, KEY BOARD (11)	
S412	1-554-303-81	SWITCH, KEY BOARD (12)	
S413	1-554-303-81	SWITCH, KEY BOARD (>12)	
S414	1-554-303-81	SWITCH, KEY BOARD (MUSIC SCAN)	
S415	1-554-303-81	SWITCH, KEY BOARD (P. SEARCH)	
S416	1-554-303-81	SWITCH, KEY BOARD (CONTINUE)	
S417	1-554-303-81	SWITCH, KEY BOARD (SHUFFLE)	
S418	1-554-303-81	SWITCH, KEY BOARD (PROGRAM)	
S419	1-554-303-81	SWITCH, KEY BOARD (EDIT/TIME FADE)	
S420	1-554-303-81	SWITCH, KEY BOARD (▶▶ ▷▷)	

Ref. No.	Part No.	Description	Remark
S421	1-554-303-81	SWITCH, KEY BOARD (◀◀ ◀◀)	
S422	1-554-303-81	SWITCH, KEY BOARD (□)	
S423	1-554-303-81	SWITCH, KEY BOARD (▣)	
S424	1-554-303-81	SWITCH, KEY BOARD (▶)	
S425	1-554-303-81	SWITCH, KEY BOARD (△OPEN/CLOSE)	
S426	1-554-303-81	SWITCH, KEY BOARD (CHECK)	
S427	1-554-303-81	SWITCH, KEY BOARD (CLEAR)	
S428	1-554-303-81	SWITCH, KEY BOARD (TIME)	
S429	1-554-303-81	SWITCH, KEY BOARD (REPEAT)	
S430	1-554-303-81	SWITCH, KEY BOARD (FADER)	
< CERAMIC >			
X401	1-577-358-21	VIBRATOR, CERAMIC (4MHZ)	

* 1-637-819-11 HP BOARD (MADE IN JAPAN M31)			
* 1-637-819-21 HP BOARD (MADE IN FRANCE M31)			
* 1-637-905-11 HP BOARD (MADE IN JAPAN 395:AEP)			
* 1-637-905-21 HP BOARD (MADE IN FRANCE 395:AEP)			

< CAPACITOR >			
C481	1-163-009-11	CERAMIC CHIP 0.001uF 10% 50V	
C482	1-163-009-11	CERAMIC CHIP 0.001uF 10% 50V	
C483	1-163-038-00	CERAMIC CHIP 0.1uF 25V (M31)	
< CONNECTOR >			
CN481	* 1-568-952-11	PIN, CONNECTOR 3P	
< JACK >			
J481	1-568-519-41	JACK, LARGE TYPE (HEADPHONES M31/ PHONES 395)	
< COIL >			
L481	1-424-090-21	COIL, LINE FILTER (395)	
L482	1-424-090-21	COIL, LINE FILTER (395)	
L483	1-424-090-21	COIL, LINE FILTER (395)	
< RESISTOR >			
R481	1-216-019-00	METAL CHIP 56 5% 1/10W	
R482	1-216-019-00	METAL CHIP 56 5% 1/10W	

* 1-632-202-11 LOADING BOARD (MADE IN JAPAN)			
* 1-632-202-21 LOADING BOARD (MADE IN FRANCE)			

LOADING	MAIN
---------	------

Ref.No.	Part No.	Description	Remark	Ref.No.	Part No.	Description	Remark
		< CONNECTOR >					
CN301	* 1-564-707-11	PIN, CONNECTOR (SMALL TYPE) 5P		C343	1-161-494-00	CERAMIC 0.022uF	25V
		< SWITCH >		C344	1-161-494-00	CERAMIC 0.022uF	25V
S191	1-572-086-11	SWITCH, LEAF (LOAD OUT)		C345	1-124-477-11	ELECT 47uF	20% 25V
S192	1-572-086-11	SWITCH, LEAF (LOAD IN)		C346	1-164-159-11	CERAMIC 0.1uF	50V
		*****		C347	1-124-477-11	ELECT 47uF	20% 25V
		* A-4617-688-A MAIN BOARD, COMPLETE		C348	1-164-159-11	CERAMIC 0.1uF	50V
		(MADE IN FRANCE M31/395)		C349	1-161-494-00	CERAMIC 0.022uF	25V
		* A-4617-701-A MAIN BOARD, COMPLETE		C350	1-124-477-11	ELECT 47uF	20% 25V
		(MADE IN JAPAN M31:AEP, Australian/395:AEP)		C351	1-161-494-00	CERAMIC 0.022uF	25V
		* A-4617-703-A MAIN BOARD, COMPLETE		C352	1-124-477-11	ELECT 47uF	20% 25V
		(MADE IN JAPAN M31:E)		C353	1-162-199-31	CERAMIC 10PF	5% 50V
		*****		C354	1-162-199-31	CERAMIC 10PF	5% 50V
		4-902-345-01 HEAT SINK		C355	1-161-494-00	CERAMIC 0.022uF	25V
		7-682-547-09 SCREW +B 3X6		C356	1-124-477-11	ELECT 47uF	20% 25V
		< CAPACITOR >		C357	1-124-472-11	ELECT 470uF	20% 10V
C201	1-124-572-11	ELECT 100uF	20% 63V	C361	1-162-285-31	CERAMIC 180PF	10% 50V
C202	1-124-907-11	ELECT 10uF	20% 50V	C362	1-162-285-31	CERAMIC 180PF	10% 50V
C203	1-124-887-00	ELECT 3300uF	20% 16V	C363	1-162-283-31	CERAMIC 120PF	10% 50V
C204	1-124-898-11	ELECT 4700uF	20% 16V	C364	1-162-283-31	CERAMIC 120PF	10% 50V
C205	1-124-927-11	ELECT 4.7uF	20% 100V	C365	1-162-283-31	CERAMIC 120PF	10% 50V
C206	1-124-907-11	ELECT 10uF	20% 50V	C366	1-162-283-31	CERAMIC 120PF	10% 50V
C207	1-124-907-11	ELECT 10uF	20% 50V	C367	1-161-494-00	CERAMIC 0.022uF	25V
C208	1-124-472-11	ELECT 470uF	20% 10V	C368	1-161-494-00	CERAMIC 0.022uF	25V
C209	1-124-472-11	ELECT 470uF	20% 10V	C371	1-106-359-00	MYLAR 4700PF	5% 200V
C210	1-124-120-11	ELECT 220uF	20% 25V	C372	1-106-359-00	MYLAR 4700PF	5% 200V
C211	1-124-472-11	ELECT 470uF	20% 10V	C373	1-106-345-00	MYLAR 0.0012uF	5% 100V
C212	1-124-472-11	ELECT 470uF	20% 10V	C374	1-106-345-00	MYLAR 0.0012uF	5% 100V
C221	1-164-159-11	CERAMIC 0.1uF	50V	C375	1-161-494-00	CERAMIC 0.022uF	25V
C301	1-124-477-11	ELECT 47uF	20% 25V	C376	1-161-494-00	CERAMIC 0.022uF	25V
C302	1-124-903-11	ELECT 1uF	20% 50V	C377	1-124-477-11	ELECT 47uF	20% 25V
C311	1-106-383-00	MYLAR 0.047uF	5% 200V	C378	1-124-477-11	ELECT 47uF	20% 25V
C312	1-161-374-11	CERAMIC 0.0015uF	20% 50V	C379	1-106-349-00	MYLAR 0.0018uF	5% 100V
C313	1-161-494-00	CERAMIC 0.022uF	25V	C380	1-106-349-00	MYLAR 0.0018uF	5% 100V
C314	1-162-306-11	CERAMIC 0.01uF	20% 16V	C392	1-164-159-11	CERAMIC 0.1uF	50V
C315	1-124-902-00	ELECT 0.47uF	20% 50V			< CONNECTOR >	
C316	1-161-494-00	CERAMIC 0.022uF	25V	CN201	* 1-580-230-11	PIN, CONNECTOR (PC BOARD) 3P	
C317	1-164-159-11	CERAMIC 0.1uF	50V	CN301	* 1-568-843-11	SOCKET, CONNECTOR 28P	
C321	1-161-494-00	CERAMIC 0.022uF	25V	CN302	* 1-568-822-11	SOCKET, CONNECTOR 22P	
C331	1-162-208-31	CERAMIC 24PF	5% 50V	CN381	* 1-564-708-11	PIN, CONNECTOR (SMALL TYPE) 6P	
C332	1-106-220-00	MYLAR 0.1uF	5% 100V	CN382	* 1-564-707-11	PIN, CONNECTOR (SMALL TYPE) 5P	
C333	1-161-494-00	CERAMIC 0.022uF	25V			< DIODE >	
C335	1-162-205-31	CERAMIC 18PF	5% 50V	D201	8-719-200-82	DIODE 11ES2	
C341	1-161-494-00	CERAMIC 0.022uF	25V	D202	8-719-109-96	DIODE RD6.8ES-B1	
C342	1-124-477-11	ELECT 47uF	20% 25V	D203	8-719-200-82	DIODE 11ES2	
				D204	8-719-200-82	DIODE 11ES2	
				D205	8-719-200-82	DIODE 11ES2	

MAIN

Ref. No.	Part No.	Description	Remark	Ref. No.	Part No.	Description	Remark
D206	8-719-200-82	DIODE 11ES2				< RESISTOR >	
D207	8-719-114-49	DIODE RD7. 5JS-B2		R201	1-249-435-11	CARBON 33K 5% 1/4W	
D208	8-719-109-89	DIODE RD5. 6ES-B2		R202	1-249-438-11	CARBON 56K 5% 1/4W	
D209	8-719-107-94	DIODE 1SS202-1 (MADE IN FRANCE)		R203	1-249-429-11	CARBON 10K 5% 1/4W	
D209	8-719-987-63	DIODE 1N4148M (MADE IN JAPAN)		R204	1-249-425-11	CARBON 4. 7K 5% 1/4W	
D341	8-719-210-21	DIODE 11EQS04		R205	1-249-425-11	CARBON 4. 7K 5% 1/4W	
D351	8-719-107-94	DIODE 1SS202-1 (MADE IN FRANCE)		R206	1-249-417-11	CARBON 1K 5% 1/4W	
D351	8-719-987-63	DIODE 1N4148M (MADE IN JAPAN)		R207	1-249-417-11	CARBON 1K 5% 1/4W	
		< IC >		R208	1-249-423-11	CARBON 3. 3K 5% 1/4W	
IC201	8-759-633-42	IC M5293L		R209	1-249-413-11	CARBON 470 5% 1/4W	
IC202	8-759-630-21	IC M5290P-16		R210	1-249-429-11	CARBON 10K 5% 1/4W	
IC203	8-759-945-58	IC RC4558P		R211	1-249-410-11	CARBON 270 5% 1/4W	
IC301	8-752-337-26	IC CXD2500AQ		R214	1-249-417-11	CARBON 1K 5% 1/4W	
IC302	8-752-328-61	IC CXD1244S		R301	1-249-417-11	CARBON 1K 5% 1/4W	
IC303	8-759-917-18	IC SN74HCU04AN		R302	1-249-417-11	CARBON 1K 5% 1/4W	
IC305	8-752-334-87	IC CXD2552Q		R303	1-249-421-11	CARBON 2. 2K 5% 1/4W	
IC306	8-759-990-82	IC TL082CP		R304	1-249-417-11	CARBON 1K 5% 1/4W	
IC307	8-759-945-58	IC RC4558P		R311	1-249-423-11	CARBON 3. 3K 5% 1/4W	
		< JACK >		R312	1-249-429-11	CARBON 10K 5% 1/4W	
J381	* 1-569-443-11	JACK, PIN 4P (LINE OUT)		R313	1-249-423-11	CARBON 3. 3K 5% 1/4W	
		< COIL >		R314	1-249-429-11	CARBON 10K 5% 1/4W	
L331	1-408-403-00	INDUCTOR 3. 3uH		R315	1-249-417-11	CARBON 1K 5% 1/4W	
		< LINK >		R316	1-249-417-11	CARBON 1K 5% 1/4W	
PS201 Δ	1-532-685-00	LINK, IC (ICP-N20)		R317	1-249-420-11	CARBON 1. 8K 5% 1/4W	
PS202 Δ	1-532-637-00	LINK, IC 1.0A (ICP-N25)		R318	1-249-441-11	CARBON 100K 5% 1/4W	
		< TRANSISTOR >		R321	1-249-417-11	CARBON 1K 5% 1/4W	
Q201	8-729-119-76	TRANSISTOR 2SA1175-HFE		R322	1-249-417-11	CARBON 1K 5% 1/4W	
Q202	8-729-140-96	TRANSISTOR 2SD774-34		R323	1-249-417-11	CARBON 1K 5% 1/4W	
Q203	8-729-111-67	TRANSISTOR 2SB1094-L		R324	1-249-418-11	CARBON 1. 2K 5% 1/4W	
Q204	8-729-900-65	TRANSISTOR DTA144ES		R331	1-249-409-11	CARBON 220 5% 1/4W	
Q205	8-729-900-89	TRANSISTOR DTC144ES		R332	1-247-887-00	CARBON 220K 5% 1/4W	
Q206	8-729-900-89	TRANSISTOR DTC144ES		R333	1-249-417-11	CARBON 1K 5% 1/4W	
Q207	8-729-230-45	TRANSISTOR 2SC2458-YGR		R334	1-249-409-11	CARBON 220 5% 1/4W	
Q208	8-729-821-73	TRANSISTOR 2SB1274SA-RS		R341	1-249-393-11	CARBON 10 5% 1/4W	
Q209	8-729-281-52	TRANSISTOR 2SC1815-Y		R342	1-249-417-11	CARBON 1K 5% 1/4W	
Q343	8-729-900-65	TRANSISTOR DTA144ES		R347	1-249-441-11	CARBON 100K 5% 1/4W	
Q344	8-729-900-89	TRANSISTOR DTC144ES		R348	1-249-429-11	CARBON 10K 5% 1/4W	
Q371	8-729-141-30	TRANSISTOR 2SC3623A-LK		R351	1-249-429-11	CARBON 10K 5% 1/4W	
Q372	8-729-141-30	TRANSISTOR 2SC3623A-LK		R352	1-249-429-11	CARBON 10K 5% 1/4W	
Q373	8-729-141-30	TRANSISTOR 2SC3623A-LK		R353	1-249-429-11	CARBON 10K 5% 1/4W	
Q374	8-729-141-30	TRANSISTOR 2SC3623A-LK		R354	1-249-429-11	CARBON 10K 5% 1/4W	
				R355	1-247-848-11	CARBON 5. 1K 5% 1/4W	
				R356	1-249-405-11	CARBON 100 5% 1/4W	
				R361	1-247-840-00	CARBON 2. 4K 5% 1/4W	
				R362	1-247-840-00	CARBON 2. 4K 5% 1/4W	
				R363	1-247-840-00	CARBON 2. 4K 5% 1/4W	

Note: The components identified by mark Δ or dotted line with mark Δ are critical for safety. Replace only with part number specified.

MAIN MOTOR VR POWER SW

Ref. No.	Part No.	Description	Remark		
R364	1-247-840-00	CARBON	2.4K	5%	1/4W
R365	1-249-432-11	CARBON	18K	5%	1/4W
R366	1-249-432-11	CARBON	18K	5%	1/4W
R367	1-249-432-11	CARBON	18K	5%	1/4W
R368	1-249-432-11	CARBON	18K	5%	1/4W
R369	1-249-419-11	CARBON	1.5K	5%	1/4W
R370	1-249-419-11	CARBON	1.5K	5%	1/4W
R371	1-249-419-11	CARBON	1.5K	5%	1/4W
R372	1-249-419-11	CARBON	1.5K	5%	1/4W
R373	1-247-887-00	CARBON	220K	5%	1/4W
R374	1-247-887-00	CARBON	220K	5%	1/4W
R375	1-249-409-11	CARBON	220	5%	1/4W
R376	1-249-409-11	CARBON	220	5%	1/4W
R377	1-249-409-11	CARBON	220	5%	1/4W
R378	1-249-409-11	CARBON	220	5%	1/4W
R379	1-249-425-11	CARBON	4.7K	5%	1/4W
R380	1-249-425-11	CARBON	4.7K	5%	1/4W
R381	1-249-425-11	CARBON	4.7K	5%	1/4W
R382	1-249-425-11	CARBON	4.7K	5%	1/4W
R383	1-249-414-11	CARBON	560	5%	1/4W
R384	1-249-414-11	CARBON	560	5%	1/4W
R389	1-249-414-11	CARBON	560	5%	1/4W
R390	1-249-414-11	CARBON	560	5%	1/4W
< SWITCH >					
S201	△ 1-571-722-11	SWITCH, VOLTAGE SELECTION (VOLTAGE SELECTOR) (M31:E)			
< CRYSTAL >					
X351	1-579-161-11	VIBRATOR, CRYSTAL (45MHz)			

* 1-637-817-11 MOTOR VR BOARD (MADE IN JAPAN M31)					
* 1-637-817-21 MOTOR VR BOARD (MADE IN FRANCE M31)					
* 1-637-907-11 MOTOR VR BOARD (MADE IN JAPAN 395)					
* 1-637-907-21 MOTOR VR BOARD (MADE IN FRANCE 395)					

* 4-922-980-01 HOLDER (LED)					
< CAPACITOR >					
C451	1-124-443-00	ELECT	100uF	20%	10V
C452	1-124-443-00	ELECT	100uF	20%	10V
C453	1-163-038-00	CERAMIC	0.1uF		25V (395)
C471	1-124-443-00	ELECT	100uF	20%	10V
C472	1-124-277-11	ELECT	4.7uF	20%	35V

Ref. No.	Part No.	Description	Remark		
< CONNECTOR >					
CN451	* 1-564-708-11	PIN, CONNECTOR (SMALL TYPE) 6P			
CN471	* 1-564-707-11	PIN, CONNECTOR (SMALL TYPE) 5P			
CN472	* 1-568-941-11	PIN, CONNECTOR 3P			
< DIODE >					
D471	8-719-970-49	DIODE BR4361F (LINE OUT M31/LEVEL 395)			
< IC >					
IC451	8-759-981-86	IC RC4556MA			
IC471	8-759-962-08	IC BA6208			
< RESISTOR >					
R451	1-216-085-00	METAL CHIP	33K	5%	1/10W
R452	1-216-085-00	METAL CHIP	33K	5%	1/10W
R453	1-216-079-00	METAL CHIP	18K	5%	1/10W
R454	1-216-079-00	METAL CHIP	18K	5%	1/10W
R455	1-216-059-00	METAL CHIP	2.7K	5%	1/10W
R456	1-216-059-00	METAL CHIP	2.7K	5%	1/10W
R457	1-216-073-00	METAL CHIP	10K	5%	1/10W
R458	1-216-073-00	METAL CHIP	10K	5%	1/10W
R461	1-216-013-00	METAL CHIP	33	5%	1/10W
R462	1-216-013-00	METAL CHIP	33	5%	1/10W
R471	1-216-037-00	METAL CHIP	330	5%	1/10W
R472	1-216-049-00	METAL CHIP	1K	5%	1/10W
R473	1-216-049-00	METAL CHIP	1K	5%	1/10W
< VARIABLE RESISTOR >					
RV451	1-238-750-11	RES. VAR. CARBON 10K/10K (PHONE LEVEL) (395)			
RV451	1-238-974-11	RES. VAR. CARBON 10K/10K (LINE OUT) (M31)			

* 1-637-818-11 POWER SW BOARD (MADE IN JAPAN M31)					
* 1-637-818-21 POWER SW BOARD (MADE IN FRANCE M31)					
* 1-637-906-11 POWER SW BOARD (MADE IN JAPAN 395)					
* 1-637-906-21 POWER SW BOARD (MADE IN FRANCE 395)					

< CONNECTOR >					
CN491	* 1-568-953-11	PIN, CONNECTOR 4P			
< SWITCH >					
S491	1-554-118-00	SWITCH, PUSH (1 KEY) (POWER)			

Note: The components identified by mark △ or dotted line with mark △ are critical for safety. Replace only with part number specified.

POWER SW

Ref. No.	Part No.	Description	Remark	Ref. No.	Part No.	Description	Remark
		MISCELLANEOUS *****				HARDWARE LIST *****	
11	△	1-574-127-31	CORD, POWER (MADE IN FRANCE:AEP)	# 1	7-682-548-09	SCREW +BVTT 3X8 (S)	
11	△	1-574-358-31	CORD, POWER (WITH CONNECTOR) (Australian)	# 2	7-682-547-04	SCREW +BVTT 3X6 (S)	
11	△	1-575-651-21	CORD, POWER (MADE IN JAPAN:AEP)	# 3	7-682-547-09	SCREW +B 3X6	
11	△	1-575-653-21	CORD, POWER (E)	# 4	7-685-646-79	SCREW +BVTP 3X8 TYPE2 N-S	
12	△	1-569-007-11	ADAPTOR, CONVERSION 2P (M31:E)	# 5	7-621-775-10	SCREW +B 2.6X4	
18		1-575-160-11	WIRE, FLAT TYPE (22 CORE)	# 6	7-685-134-19	SCREW +BTP 2.6X8 TYPE2 N-S	
61	△	1-574-127-31	CORD, POWER (MADE IN FRANCE 395:AEP)	# 7	7-621-255-15	SCREW +P 2X3	
61	△	1-575-651-21	CORD, POWER (MADE IN JAPAN 395:AEP)				
67		1-575-160-11	WIRE, FLAT TYPE (22 CORE)				
311	*	1-452-538-11	MAGNET				
354		1-575-001-11	WIRE, FLAT TYPE (12 CORE)				
357	△	8-848-144-11	DEVICE, OPTICAL KSS-240A				
CN401		1-535-883-11	JUMPER, FILM (WITH TERMINAL)				
CN401		1-535-883-11	JUMPER, FILM (WITH TERMINAL)				
D471		8-719-970-49	DIODE BR4361F (PHONE LEVEL 395)				
FLD401		1-519-611-11	INDICATOR TUBE, FLUORESCENT				
M101		X-4917-504-1	MOTOR, ASSY (SLED)				
M102		X-4917-523-3	MOTOR, ASSY (SPINDLE)				
M191	Y A	A-4604-363-A	MOTOR (L) ASSY (LOADING)				
T901	△	1-449-922-11	TRANSFORMER, POWER (MADE IN JAPAN M31:AEP, Australian)				
T901	△	1-449-923-11	TRANSFORMER, POWER (M31:E)				
T901	△	1-449-925-11	TRANSFORMER, POWER(MADE IN FRANCE M31:AEP)				
T901	△	1-449-922-11	TRANSFORMER, POWER (MADE IN JAPAN 395:AEP)				
T901	△	1-449-925-11	TRANSFORMER, POWER (MADE IN FRANCE 395:AEP)				

ACCESSORY & PACKING MATERIAL *****							
		1-465-598-11	COMMANDER, REMOTE (RM-D391) (MADE IN JAPAN)				
		1-465-598-21	COMMANDER, REMOTE (RM-D391) (MADE IN FRANCE)				
		1-558-271-11	CORD, CONNECTION				
		2-181-754-01	COVER (MLY), BATTERY				
		3-752-735-11	MANUAL, INSTRUCTION (MADE IN JAPAN) (English, FRENCH, SPANISH, PORTUGUESE)				
		3-752-735-41	MANUAL, INSTRUCTION (MADE IN JAPAN: AEP) (GERMAN, DUTCH, SWEDISH, ITALIAN)				
		3-752-735-51	MANUAL, INSTRUCTION (MADE IN FRANCE) (English, FRENCH, SPANISH, PORTUGUESE)				
		3-752-735-61	MANUAL, INSTRUCTION (MADE IN FRANCE) (GERMAN, DUTCH, SWEDISH, ITALIAN)				
	*	4-922-998-03	CUSHION (MADE IN JAPAN M31)				
	*	4-925-389-01	CUSHION (MADE IN JAPAN 395)				
	*	4-927-355-02	CUSHION (MADE IN FRANCE M31:AEP)				
	*	4-929-506-02	CUSHION (MADE IN FRANCE 395)				
	*	4-941-548-01	LABEL, CLASS 1				
	*	4-939-718-31	INDIVIDUAL CARTON (MADE IN JAPAN 395)				
	*	4-942-897-01	INDIVIDUAL CARTON (MADE IN FRANCE 395)				
	*	4-942-898-01	INDIVIDUAL CARTON (MADE IN FRANCE M31)				
	*	4-944-042-31	INDIVIDUAL CARTON (MADE IN JAPAN M31)				

Note: The components identified by mark △ or dotted line with mark △ are critical for safety. Replace only with part number specified.