

SAMSUNG BN44-00121J

7-3 IP Board Part (SMPS Part)

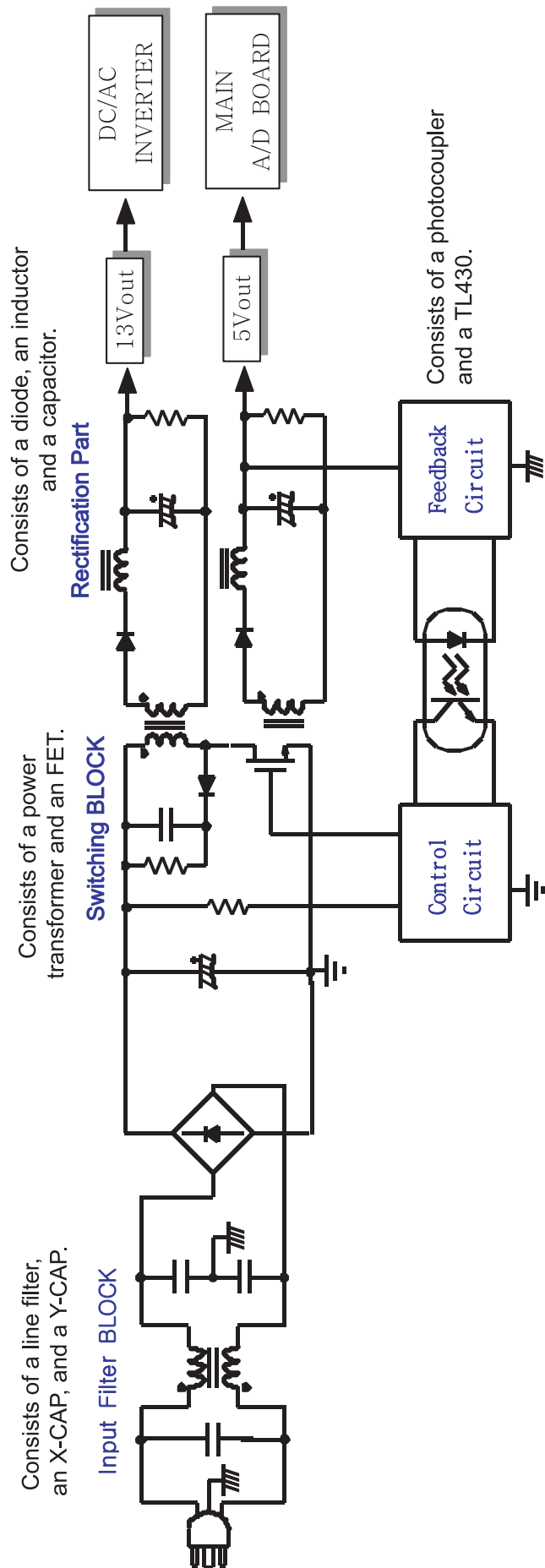

7-4 IP Board Part (Inverter Part)

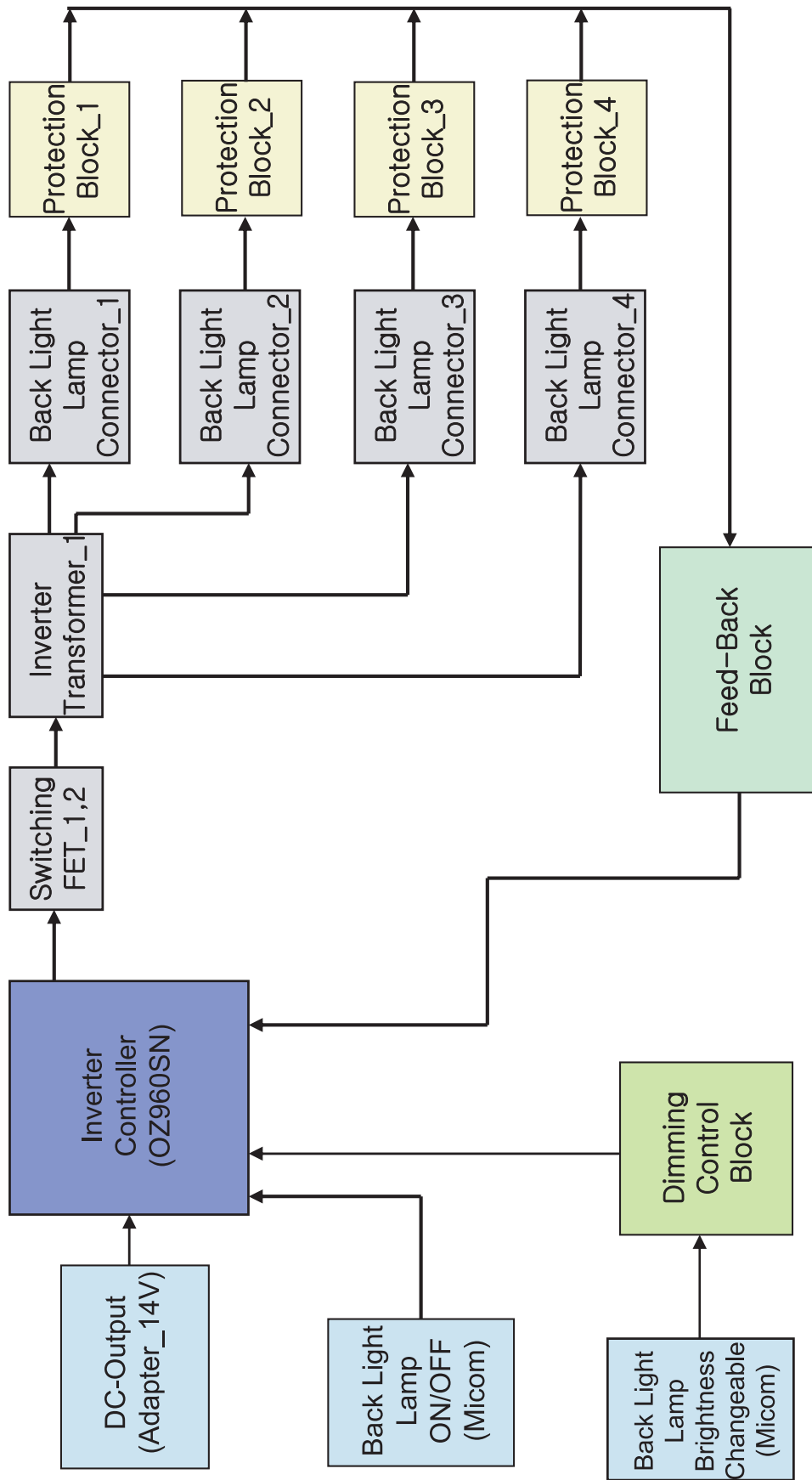

13-1-5 IP BOARD(inverter) PROTECTION Parts

PROTECTION Parts

- PROTECTION Parts are divided two parts. When lamp voltage rose as absurd and lamp feedback electric current would not be sensed. So all of the two halt IP-Board's function that prevent action the enemy more than IP-Board's continous abnormality action.
- When Trans output voltage rose as absurd, become OVP and halts IP-board's function because the divided voltage is inputted by IC(U201) 2 PIN.
- When lamp current is sensed, become OLP and halts IC because the IC(U201) 2 PIN is became under 2.5V

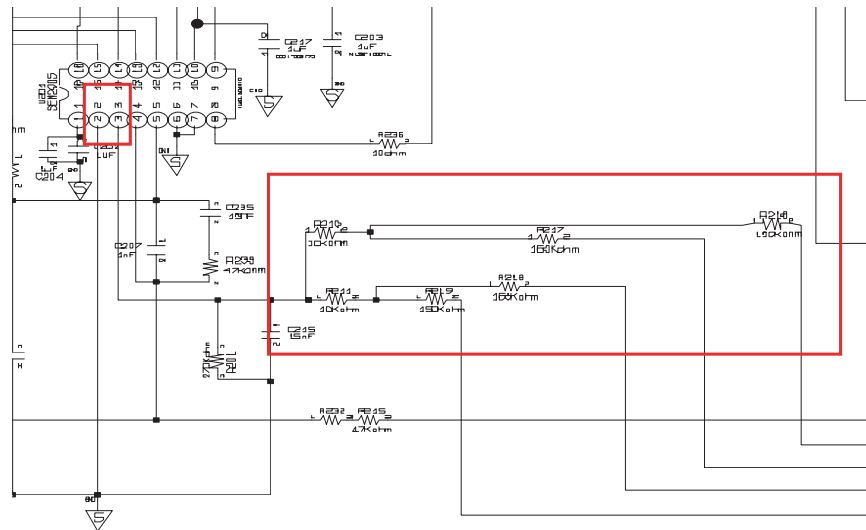
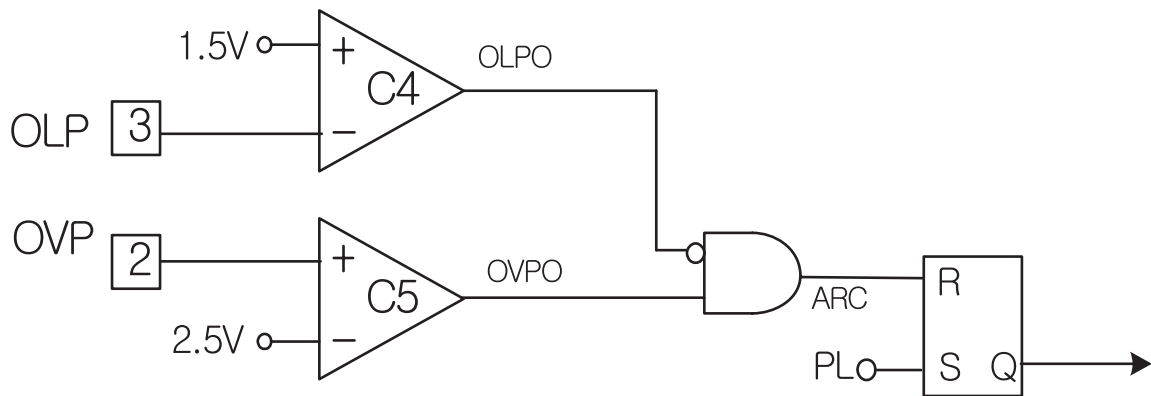

13-2 Trouble Shooting

13-2-1 IP BOARD(Power)

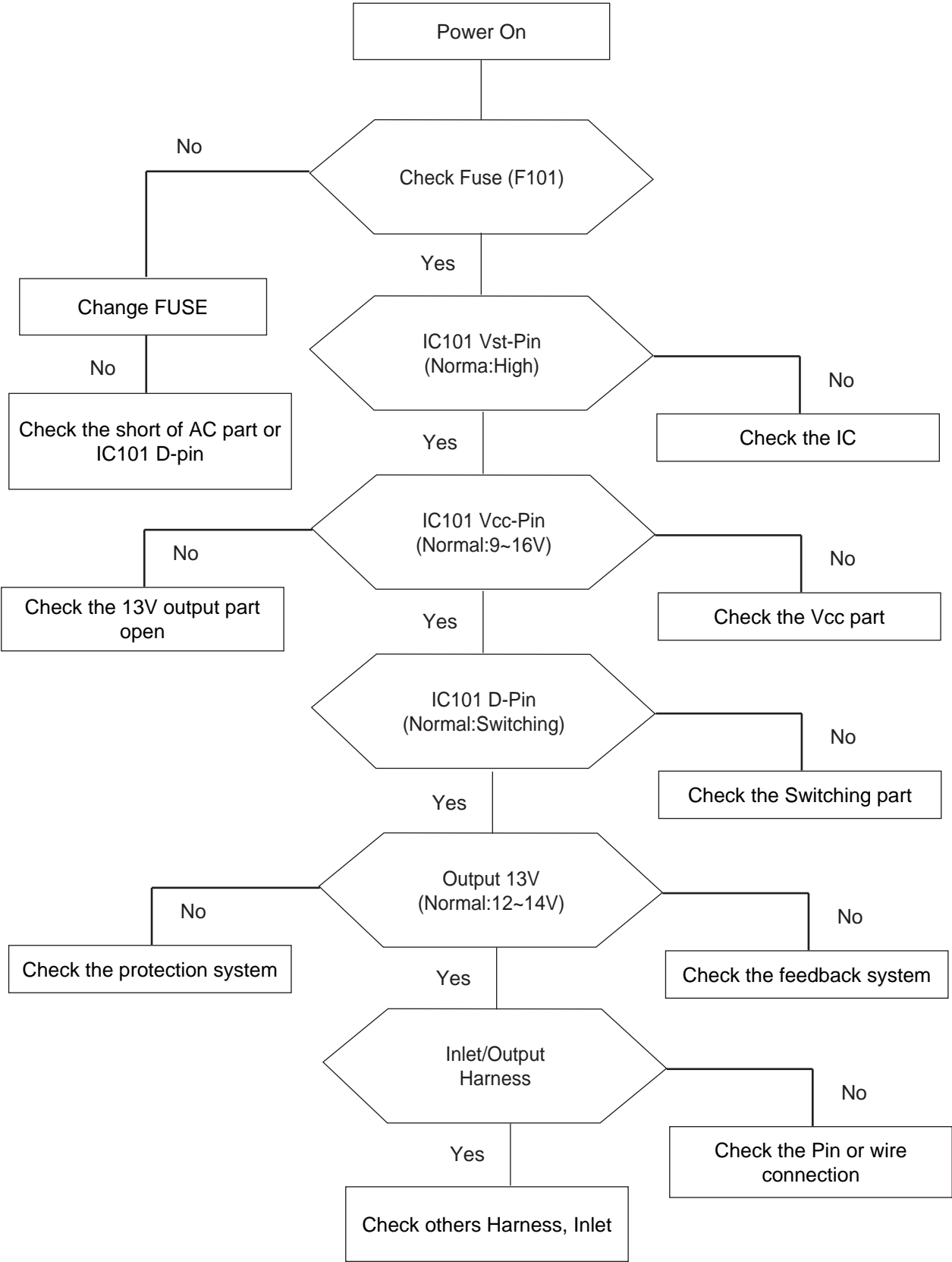

13-2-1 IP BOARD(Inverter)

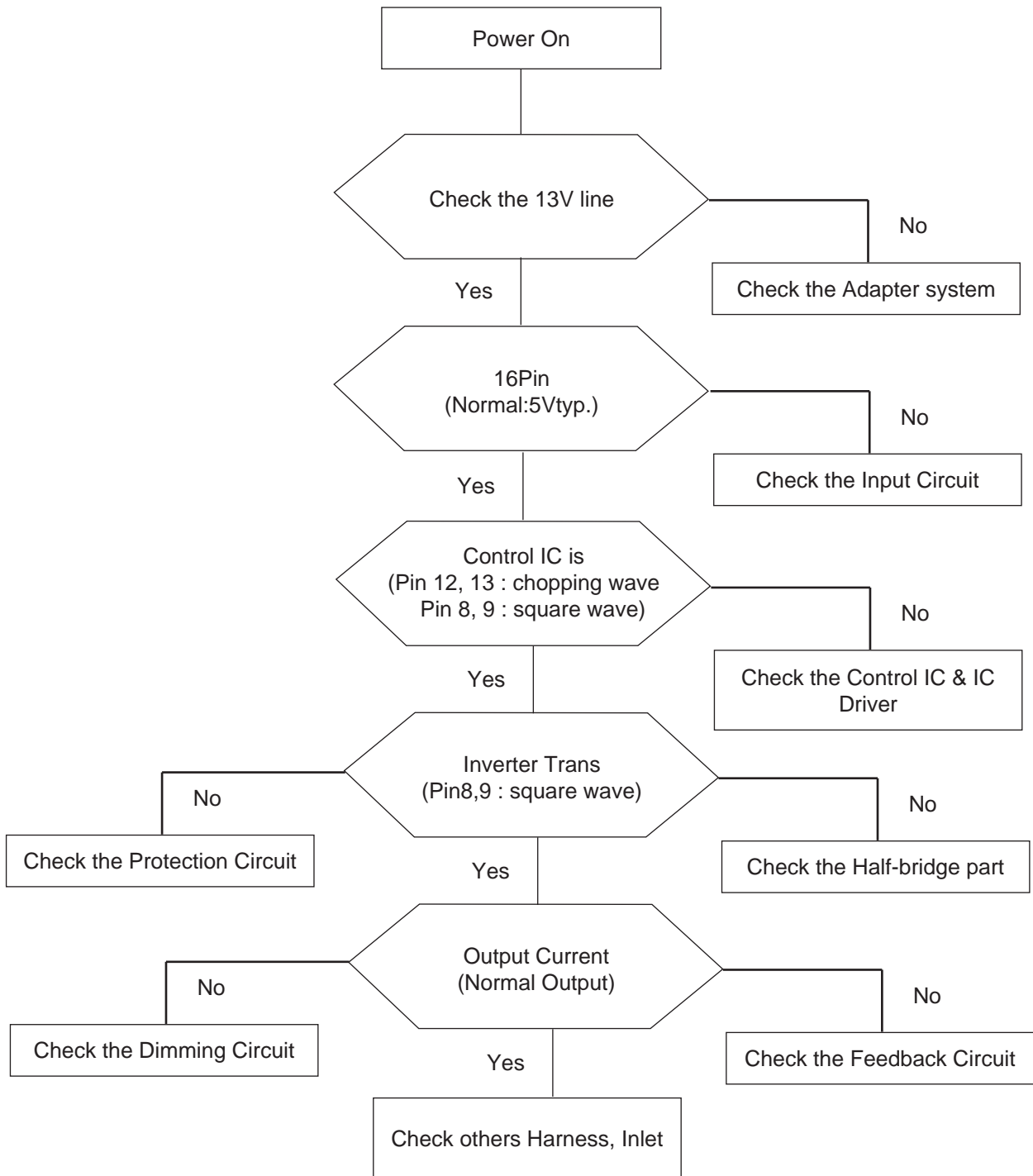

13-3 IP BOARD(Power) Schematic Diagrams

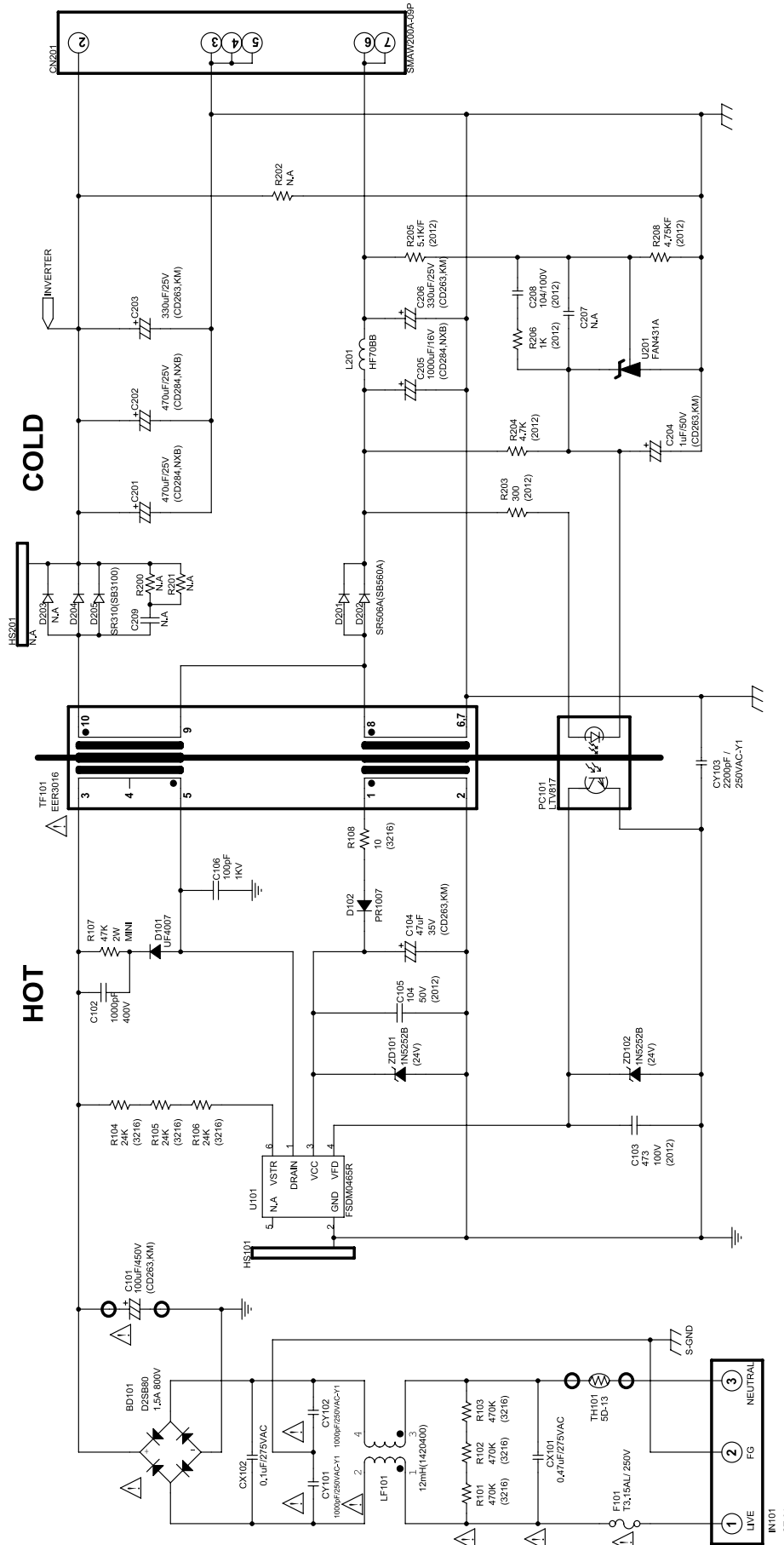

13-4 IP BOARD(Inverter) Schematic Diagrams

