

10.5 A 715G6960 PSU
10-5-1 AC input

A01

AC input

A01

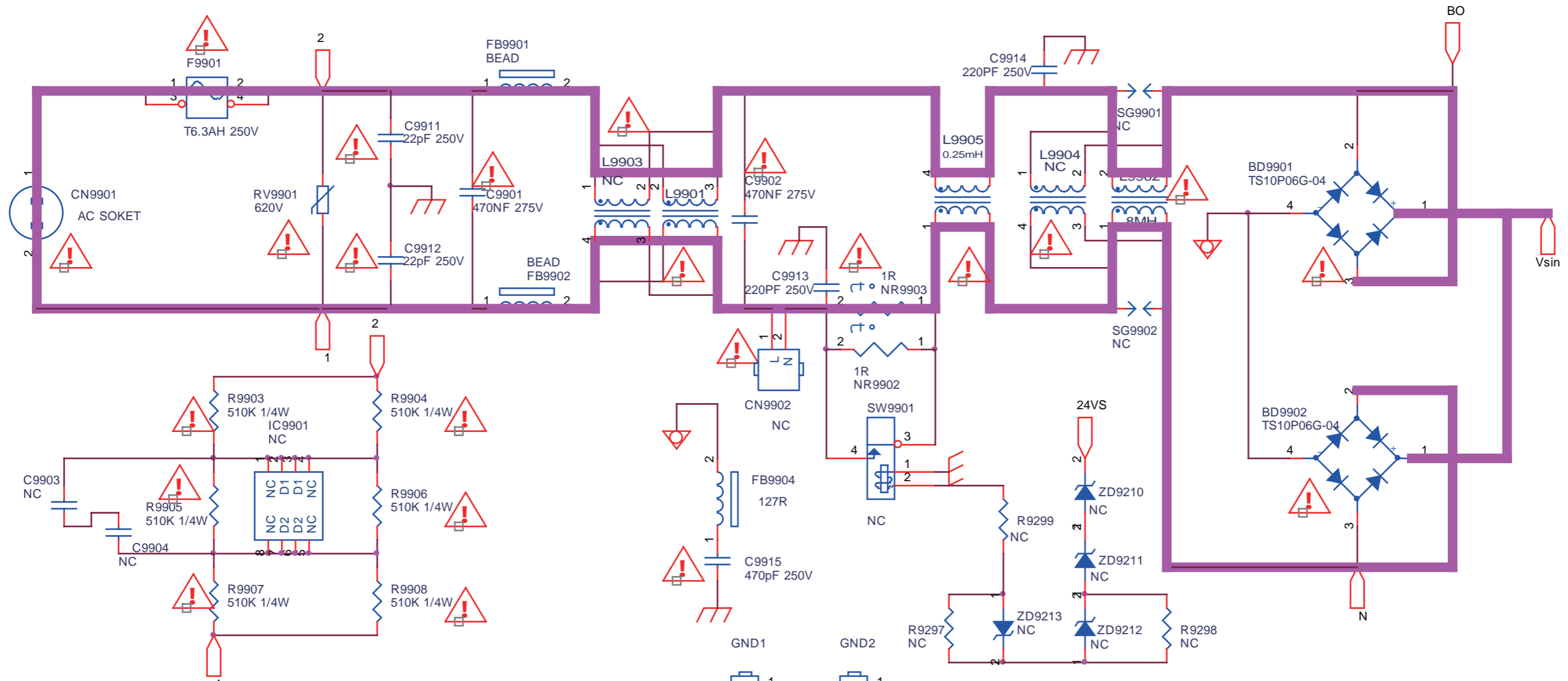

		1	2
Discharge resistor	R9903	1M	510K
	R9904	1M	510K
	R9905	NC	510K
	R9906	NC	510K
	R9907	1M	510K
	R9908	1M	510K
	IC9901	CAP004	NC
	C9901	47PF	NC

AC input	715G6960	2015-03-30
----------	----------	------------

A02

PFC with LD7591T

A02

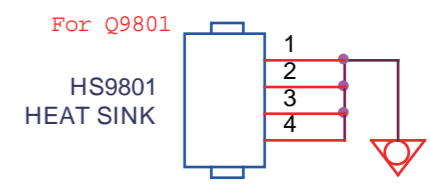
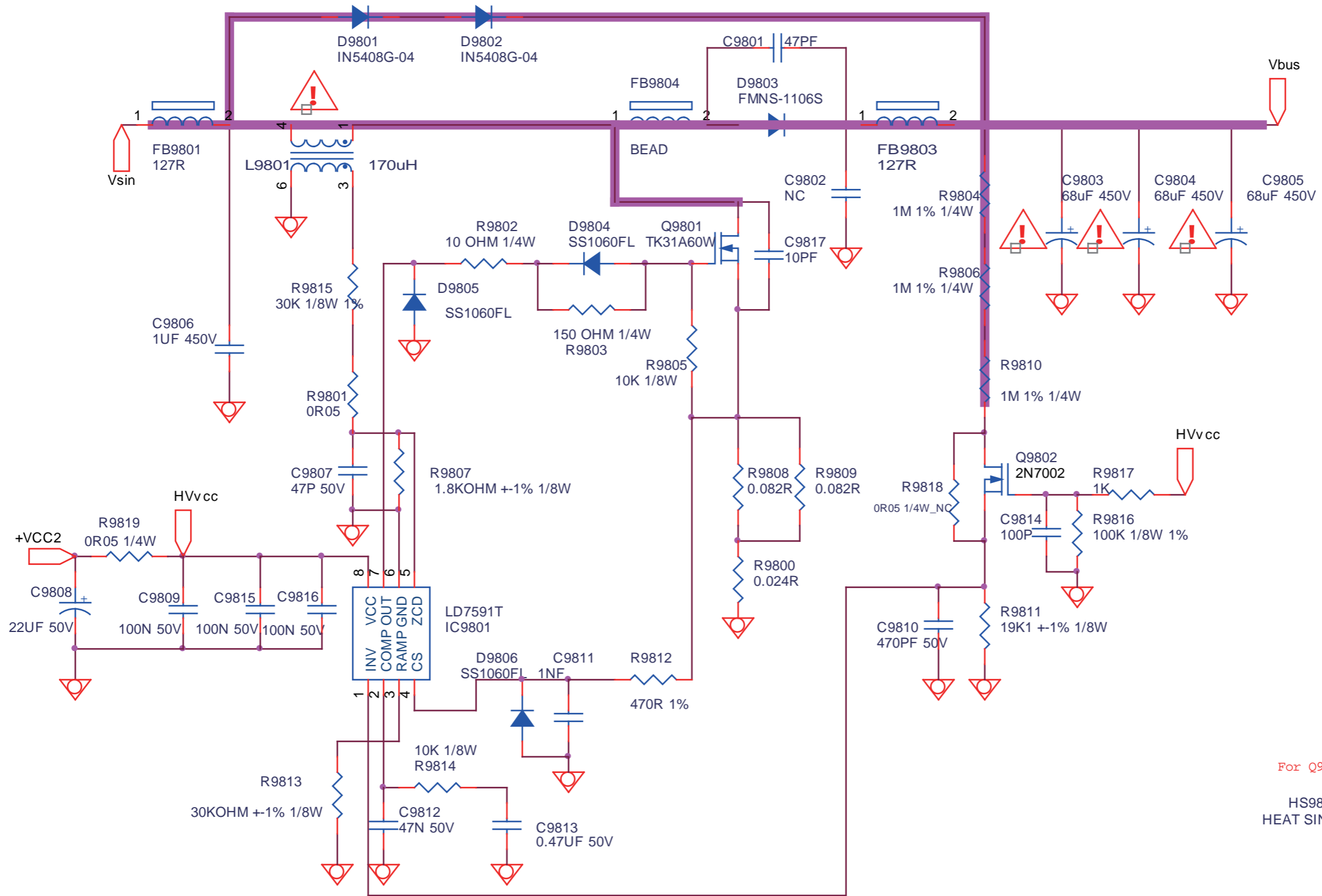

PFC with LD7591T	715G6960	2015-03-05

A03

Flyback with LD5522

A03

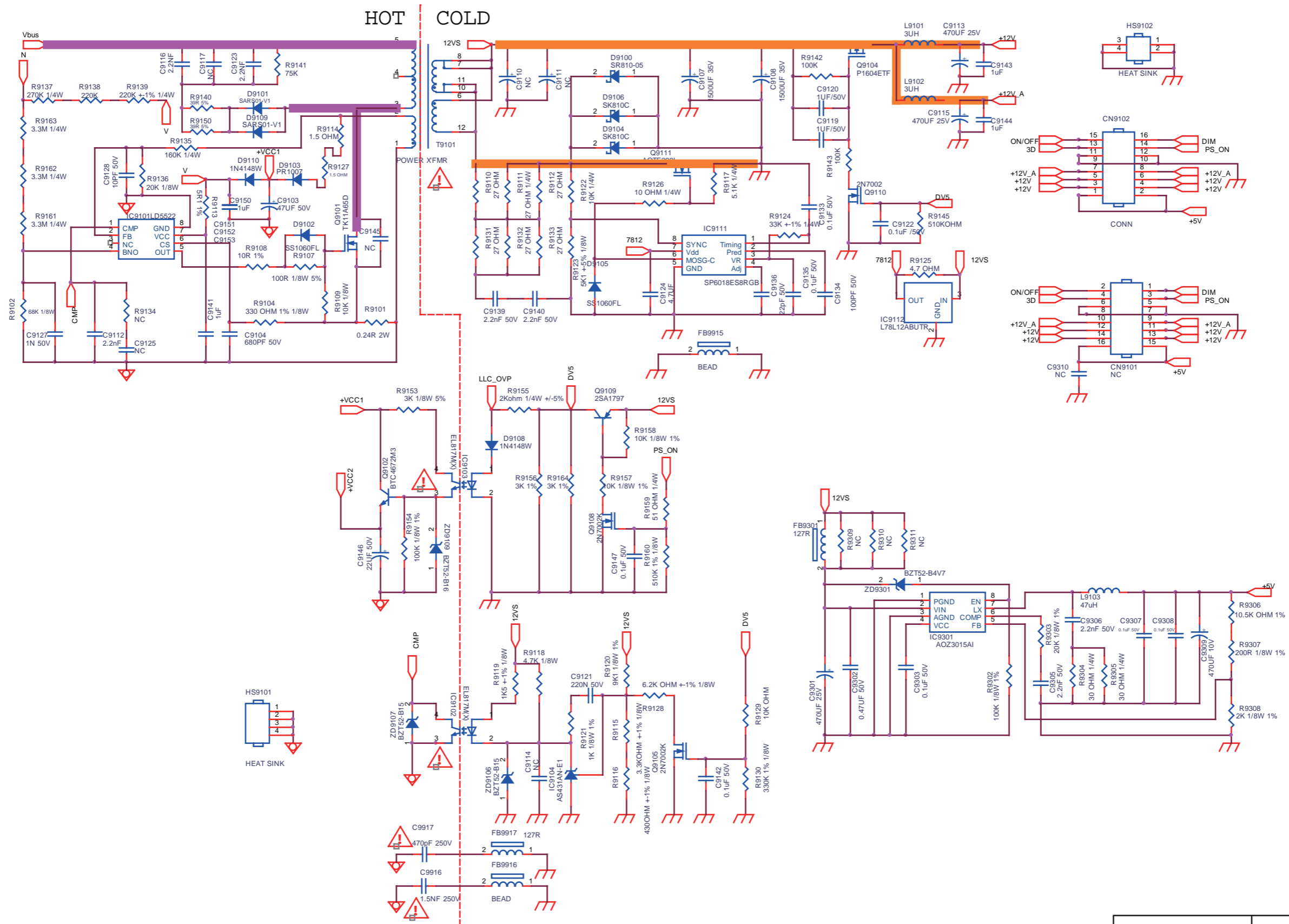

Flyback with LD5522	715G6960	2015-03-05

A04

LLC with Sanken

A04

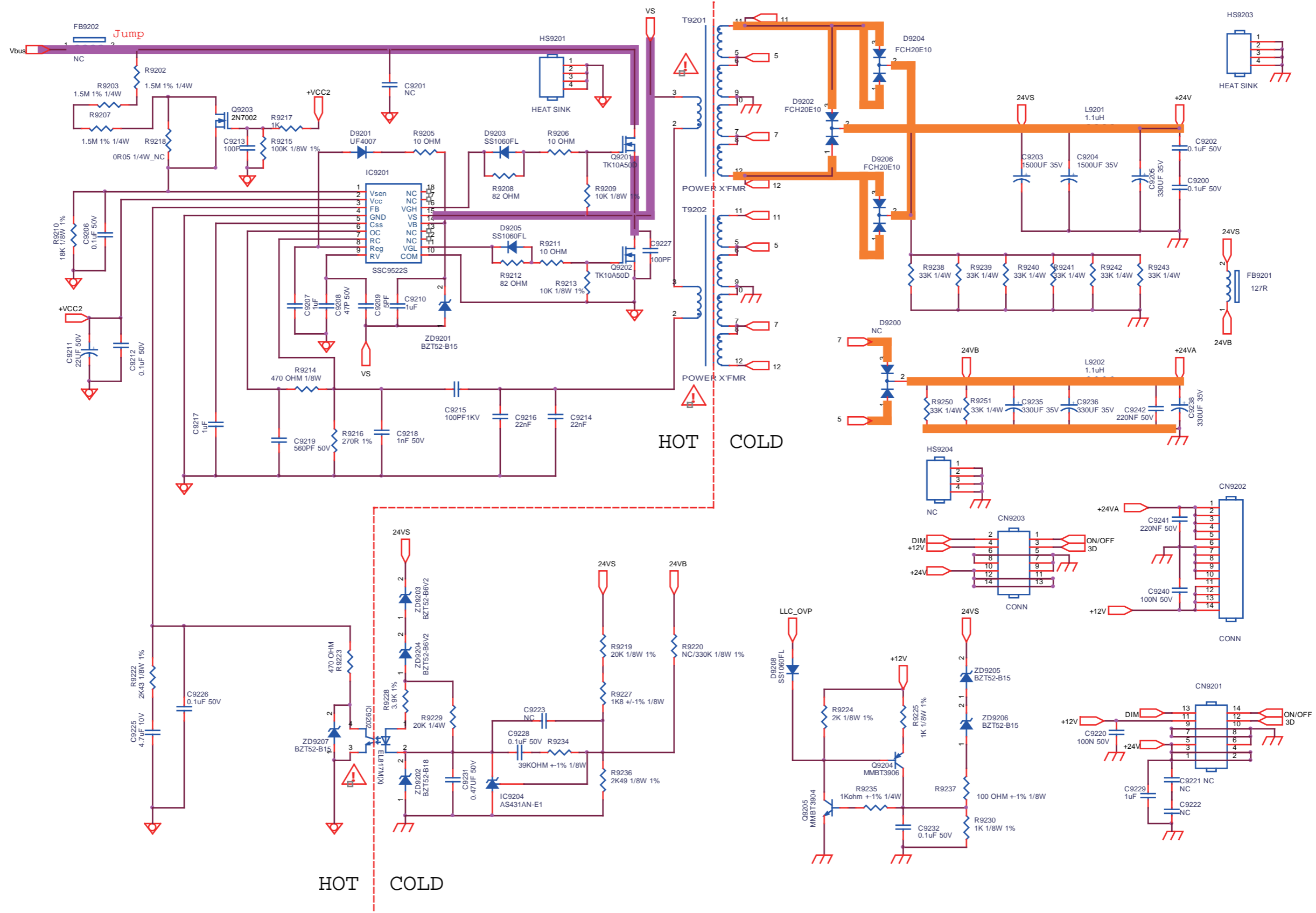

LLC with Sanken	715G6960	2015-03-08

10-5-5 Power layout top

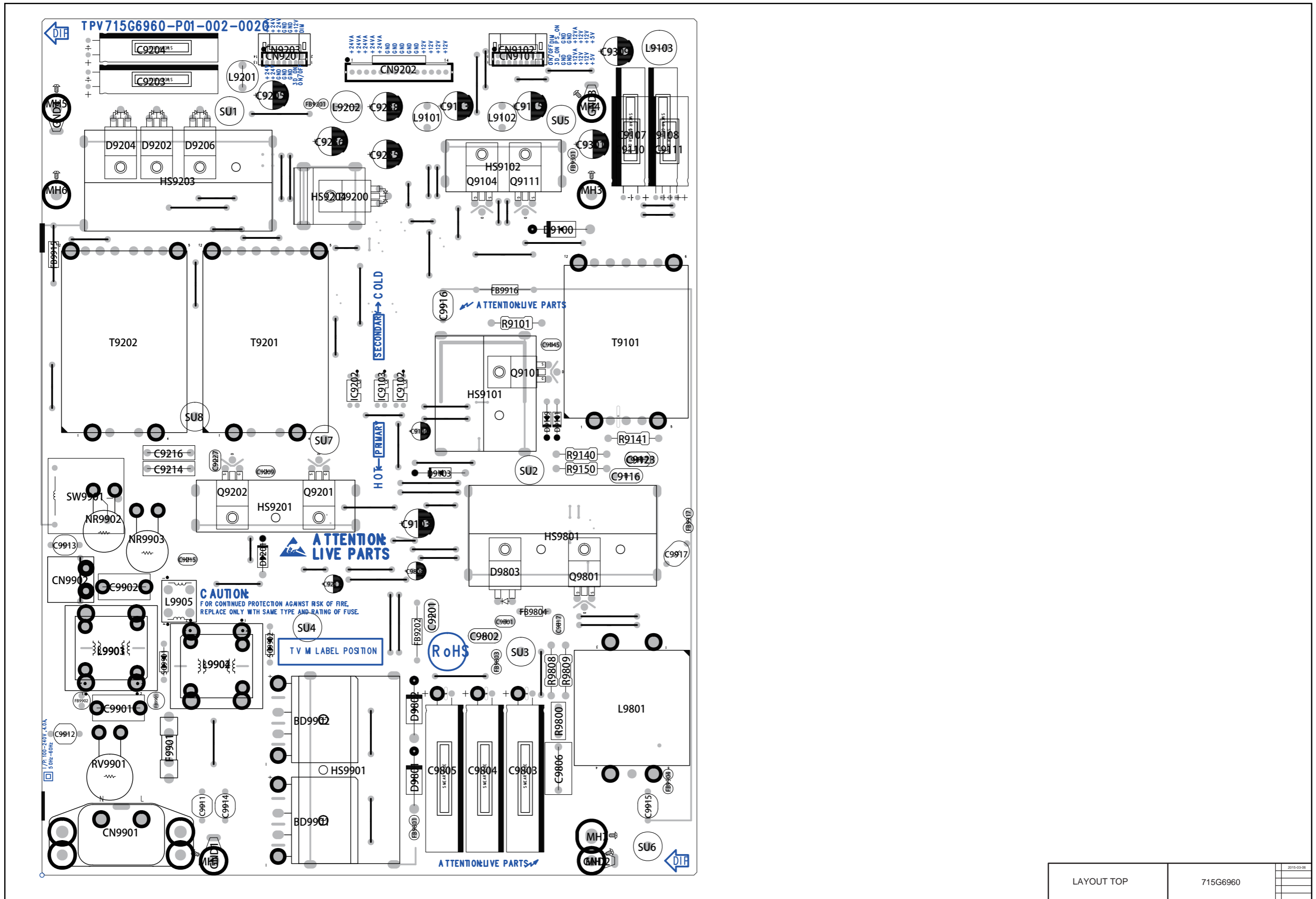

LAYOUT TOP	715G6960	2015-03-05

10-5-6 Power layout bottom

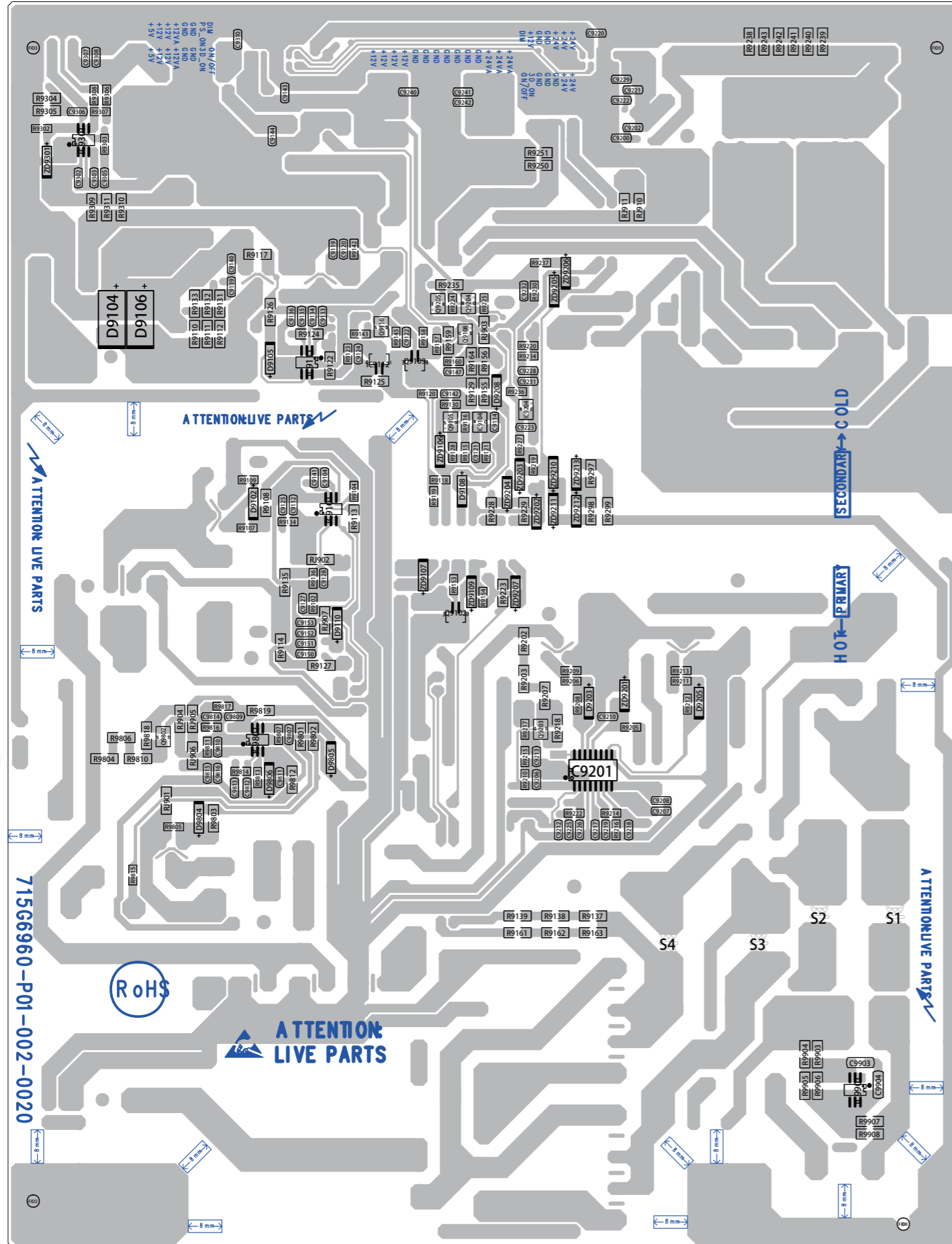

LAYOUT BOTTOM	715G6960	2015-03-08