

LED PART

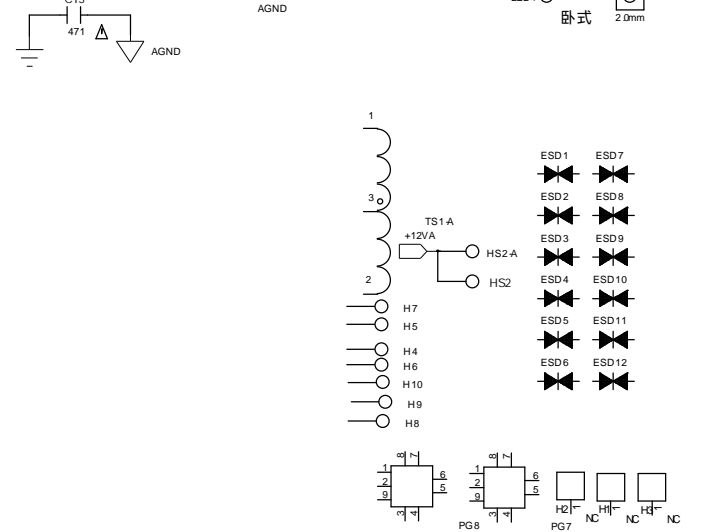
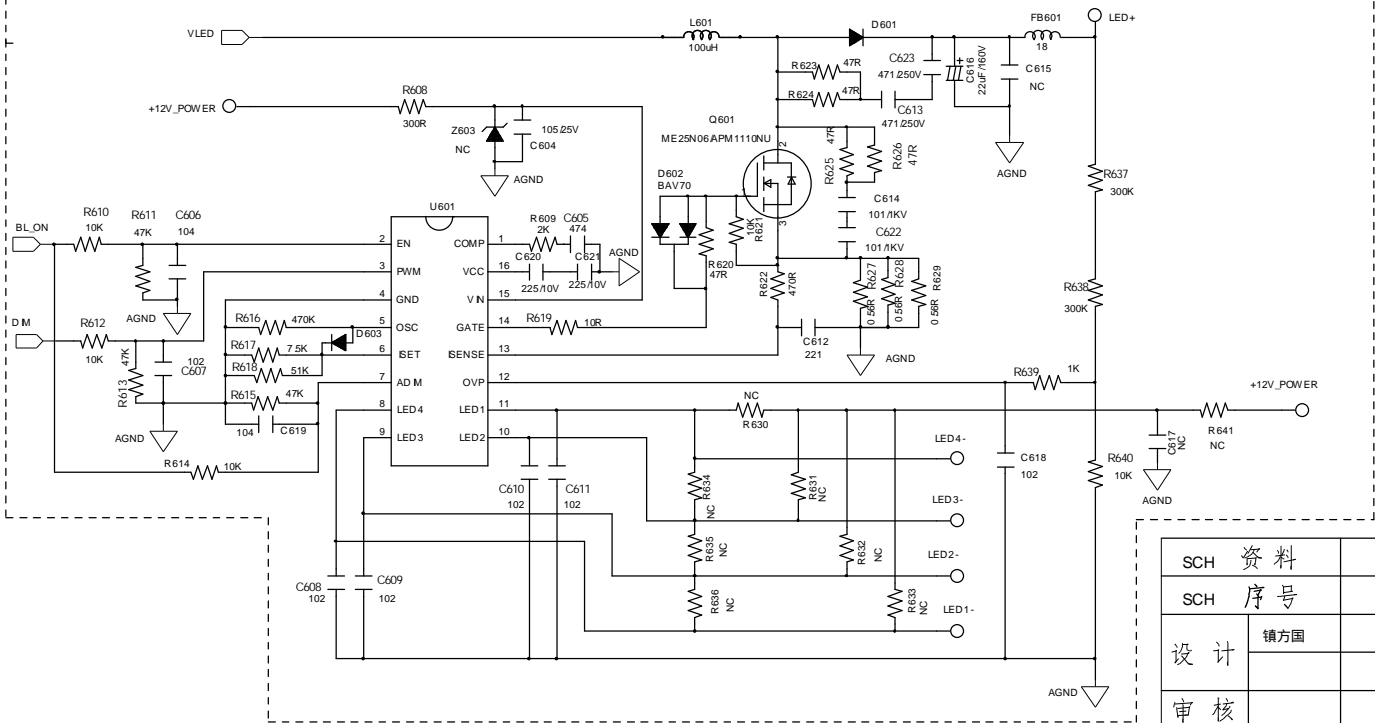

SCH 资料	共 1 张
SCH 序号	第 1 张
设计	镇方国
审核	
批准	

原理图

版本号	V1.0
文件编号	
产品型号	M PE07R 系列 POWER

REVISION RECORD			
LTR	ECO NO.	APPROVED:	DATE:

### DC/DC

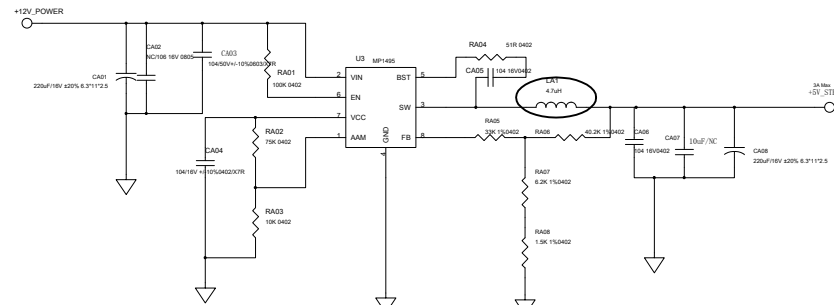

$$V_{out} = 0.8X(1+R1/R2)=5.04$$

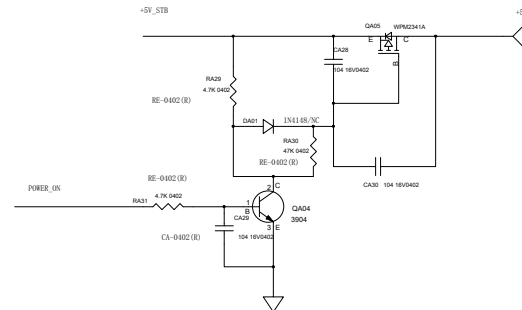

### 3.3V\_STANDBY

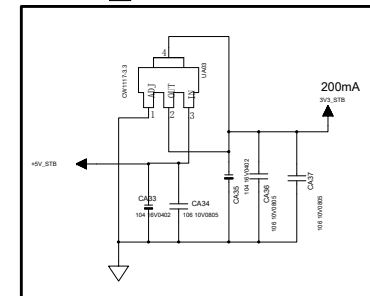

### 1.5V\_DDRV

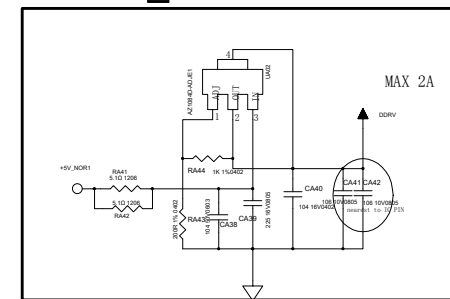

### VCC3. 3V A/DVDD

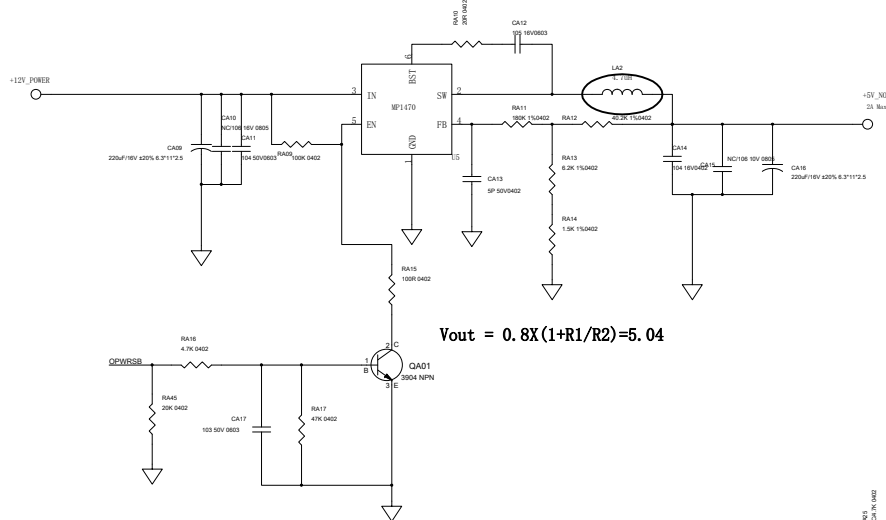
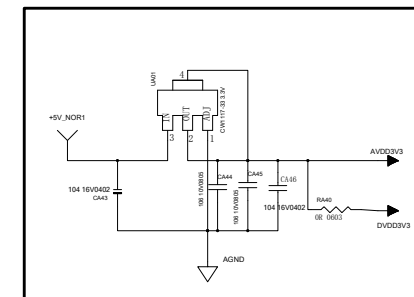

$$V_{out} = 0.8X(1+R1/R2)=5.04$$

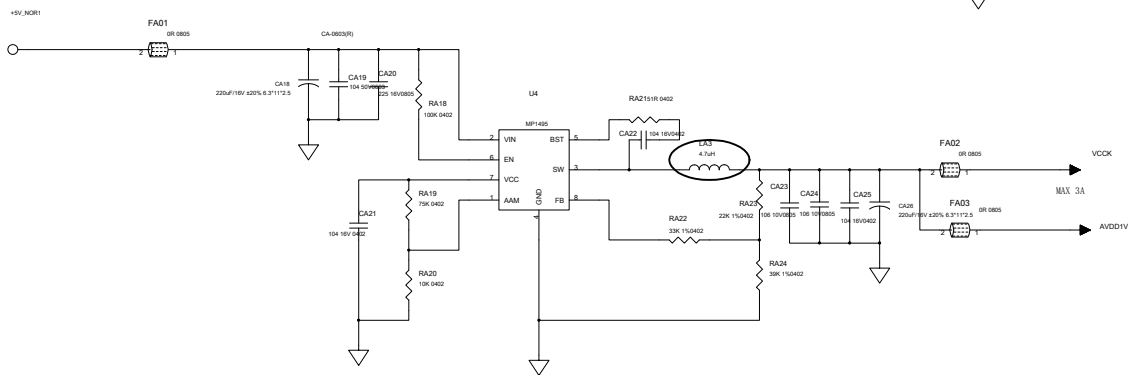
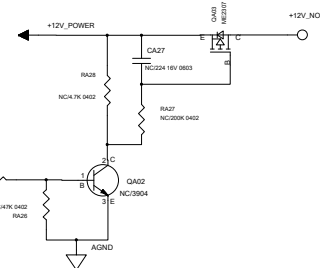
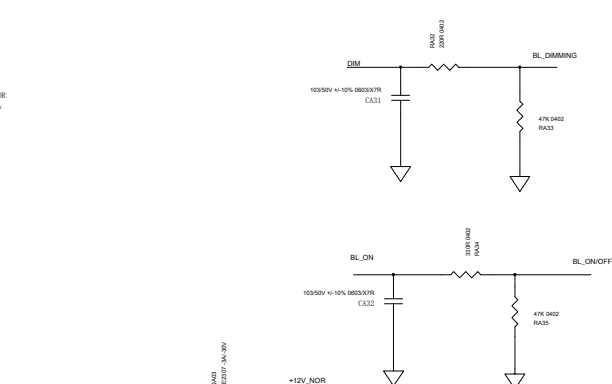

COMPANY:			
TITLE:			
DRAWN:	DATED:	CODE:	SIZE:
CHECKED:	DATED:	DRAWING NO.:	REV.:
QUALITY CONTROL:	DATED:	A1	
RELEASED:	DATED:		
SCALE:		SHEET: 12 / 12	

REVISION RECORD			
LTR	ECO NO.	APPROVED:	DATE:

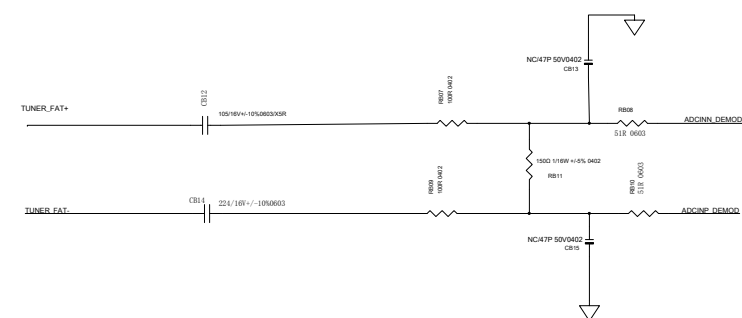
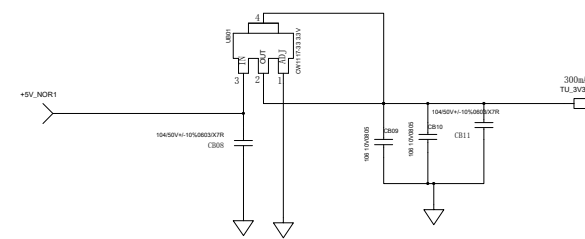
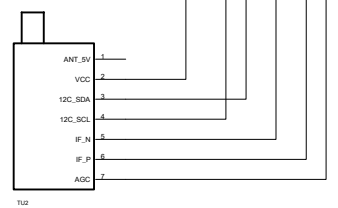
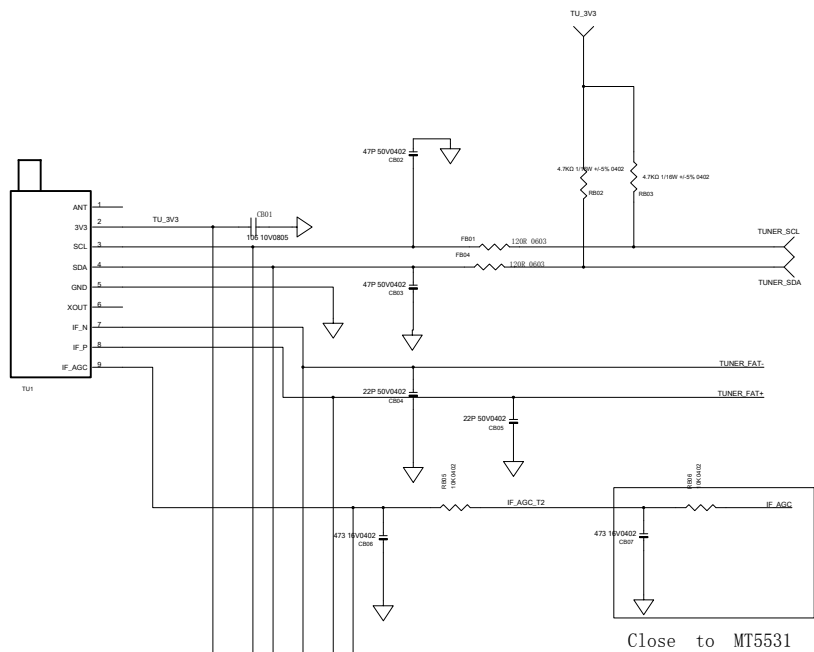

COMPANY:			
TITLE:			
DRAWN:	DATED:	CODE:	SIZE:
CHECKED:	DATED:	DRAWING NO.:	REV.:
QUALITY CONTROL:	DATED:	<b>A1</b>	
RELEASED:	DATED:		
SCALE:		SHEET: 08 12	

REVISION RECORD			
LTR	ECO NO.	APPROVED:	DATE:

YPBPR IN

CLOSE TO MT5531

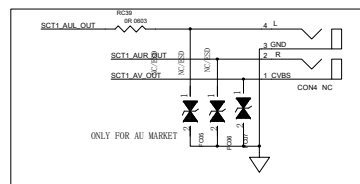
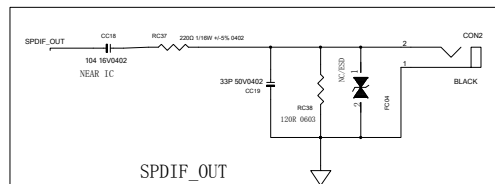
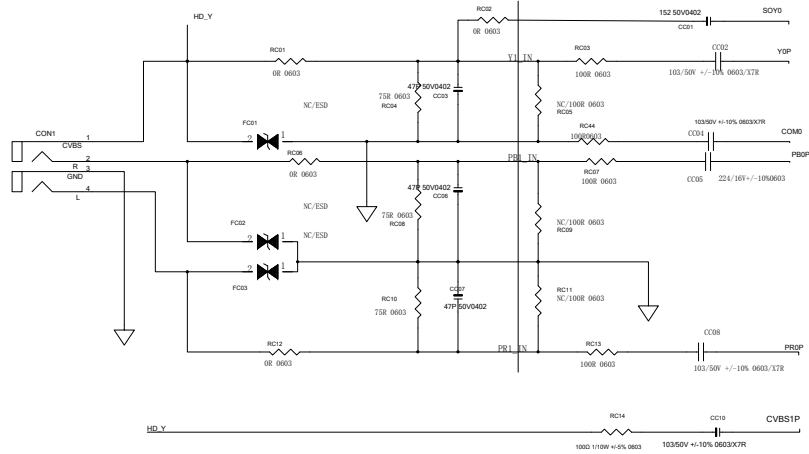

USB CONNECTOR

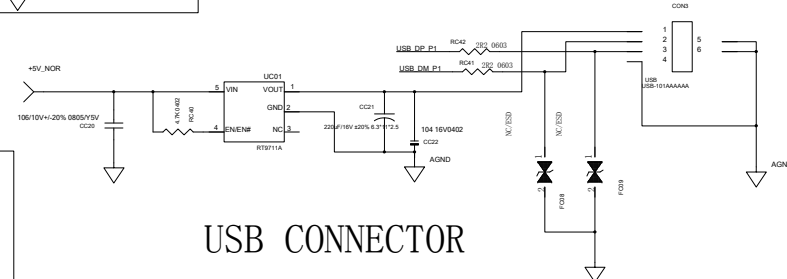

CLOSE TO MT5531

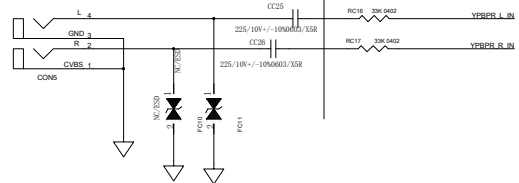

CVBS OUT

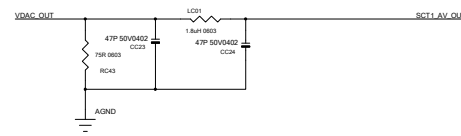

AUDIO OUTPUT

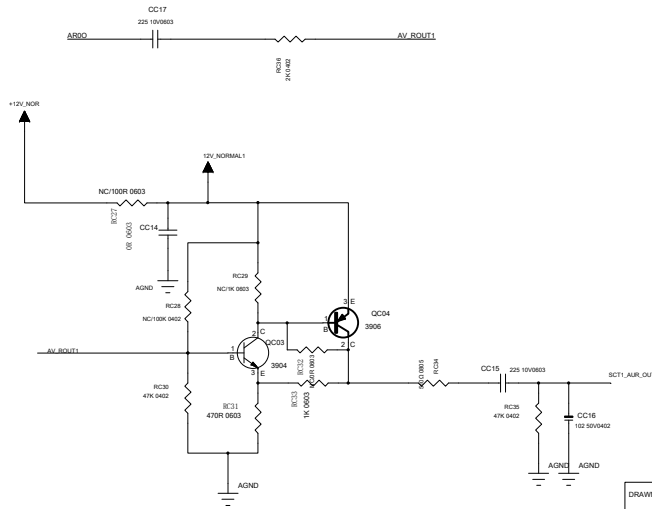
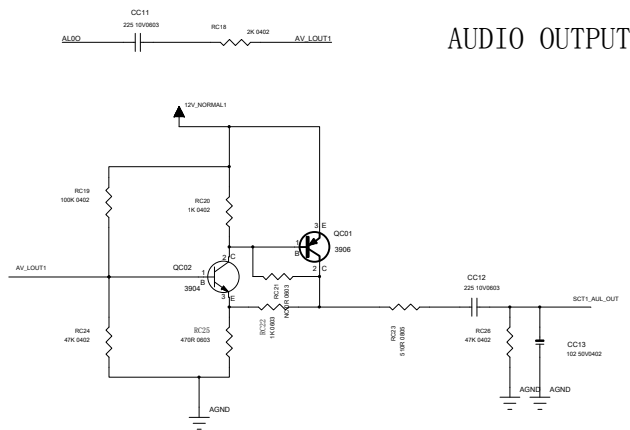

COMPANY:			
TITLE:			
CODE:	SIZE:	DRAWING NO.:	REV.:
A1			
SCALE:		SHEET: 04 12	

DRAWN:	DATED:
CHECKED:	DATED:
QUALITY CONTROL:	DATED:
RELEASED:	DATED:

REVISION RECORD			
LTR	ECO NO.	APPROVED:	DATE:

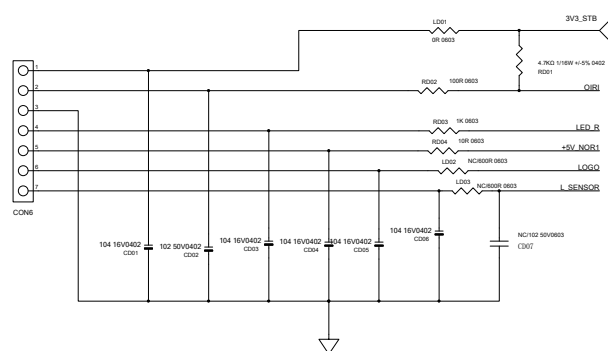

POWER INTERFACE

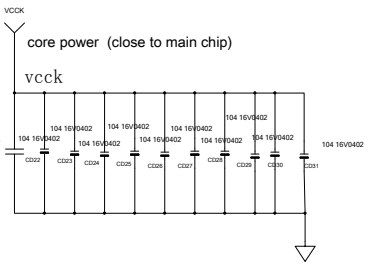
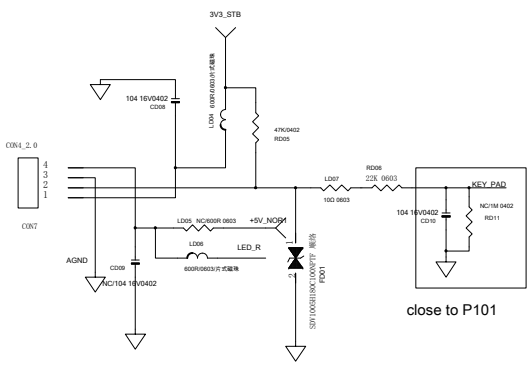
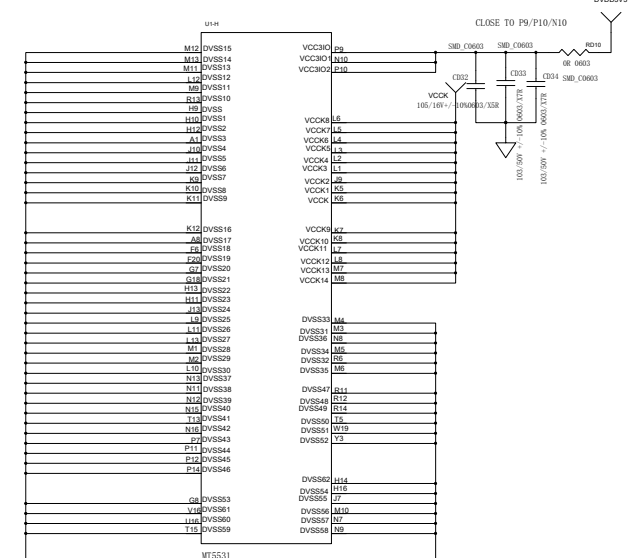

DDR3 POWER

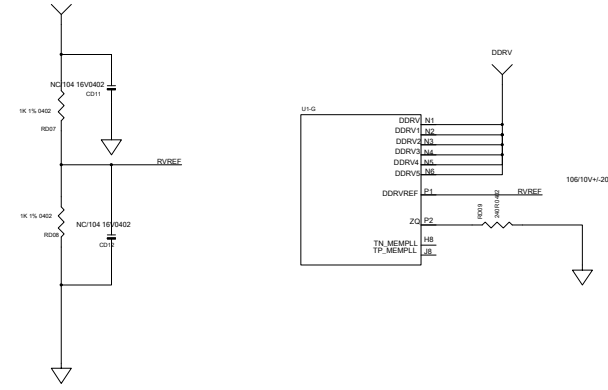

DDR IO POWER (close to main chip)

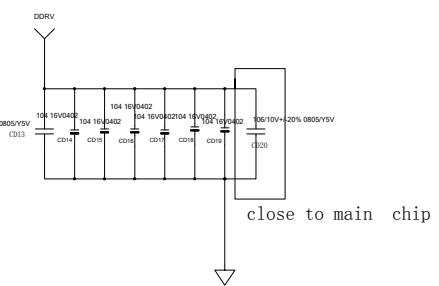

COMPANY:  
TITLE:

DRAWN:	DATED:	CODE:	SIZE:	DRAWING NO.:	REV.:
CHECKED:	DATED:		A1		
QUALITY CONTROL:	DATED:				
RELEASED:	DATED:				

REVISION RECORD			
LTR	ECO NO.	APPROVED	DATE

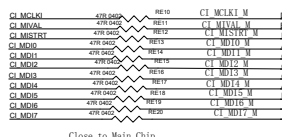
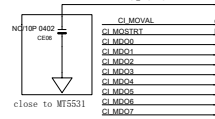
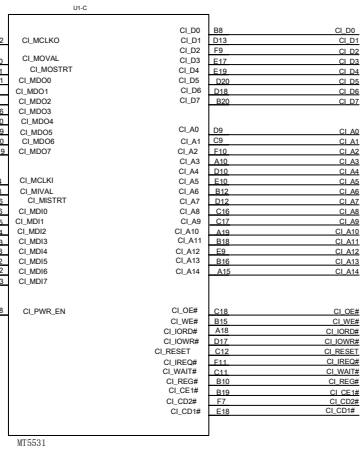
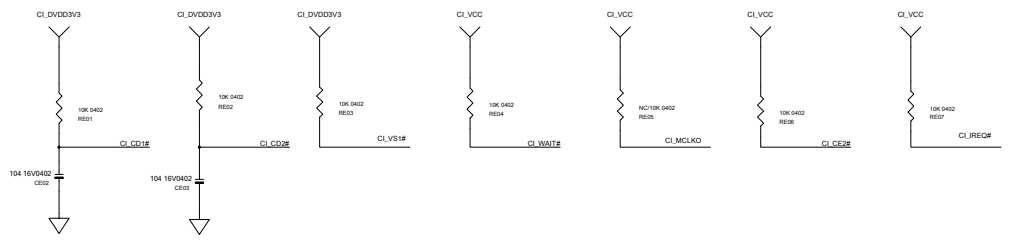
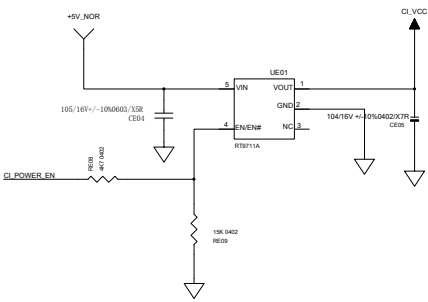
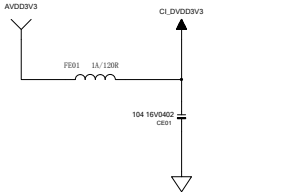

Close to Main Chip

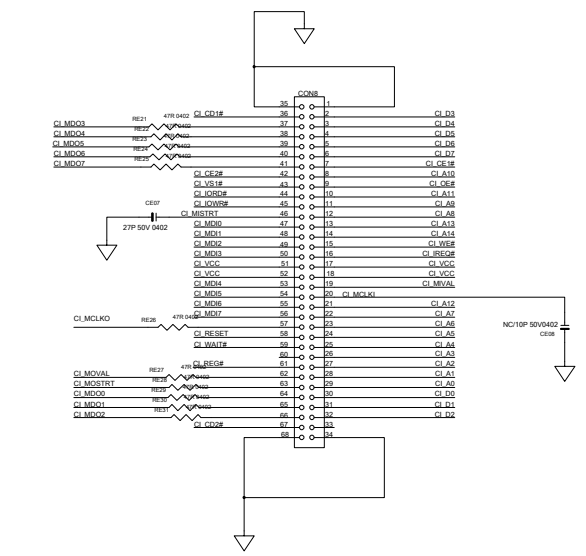
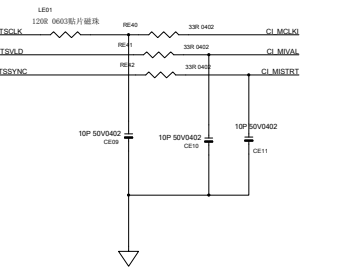
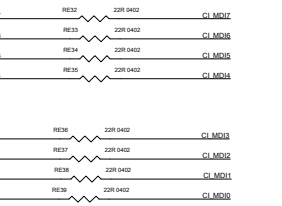

COMPANY:					
TITLE:					
DRAWN:	DATED:	CODE:	SIZE:	DRAWING NO.:	REV:
CHECKED:	DATED:	A1			
QUALITY CONTROL:	DATED:				
RELEASED:	DATED:	SCALE:	SHEET: 6		12

D

C

B

A

D

C

B

A



REVISION RECORD			
LTR	ECO NO.	APPROVED:	DATE:

# Audio&Video

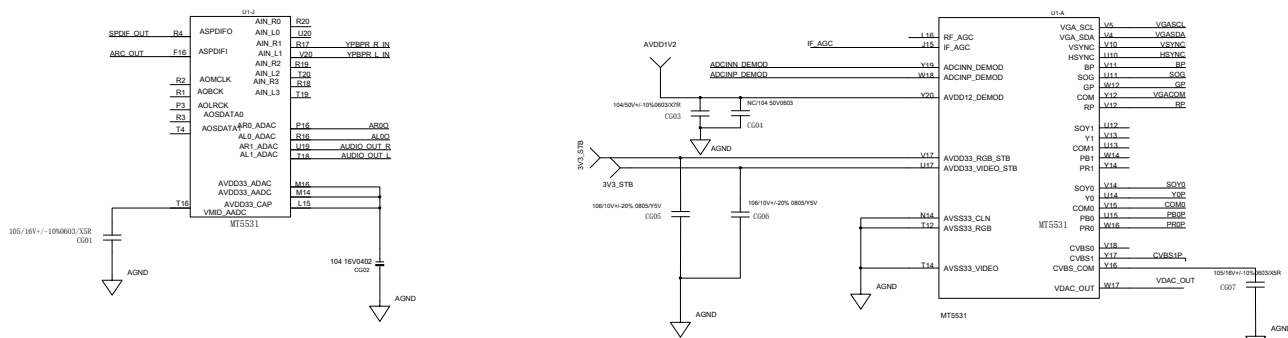

# Serial Flash

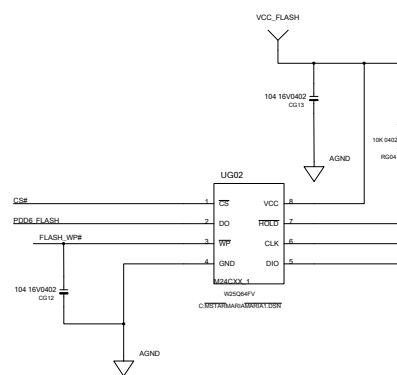
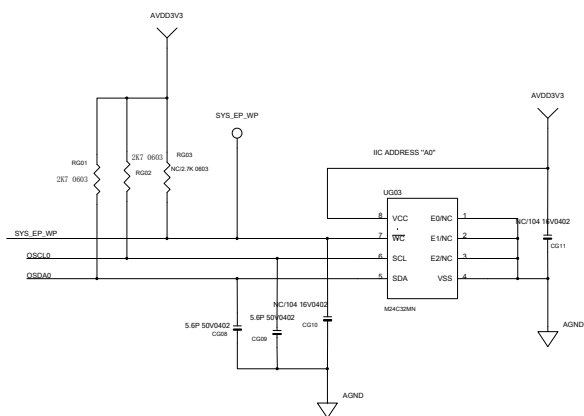
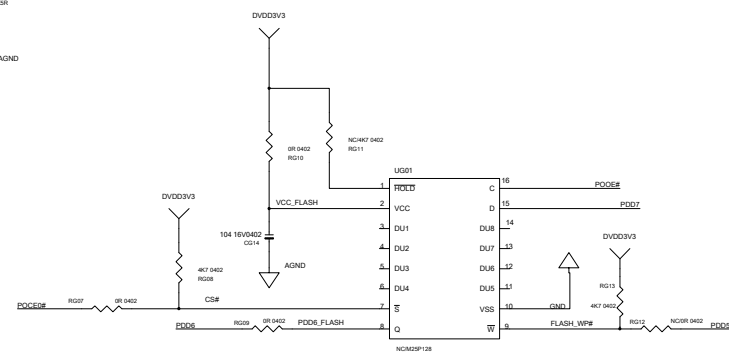

COMPANY:

TITLE:

DRAWN:	DATED:
CHECKED:	DATED:
QUALITY CONTROL:	DATED:
RELEASED:	DATED:

CODE:	SIZE:	DRAWING NO.:	REV.:
SCALE:		SHEET: 08 12	

# A1



REVISION RECORD			
LTR	ECO NO.	APPROVED:	DATE:

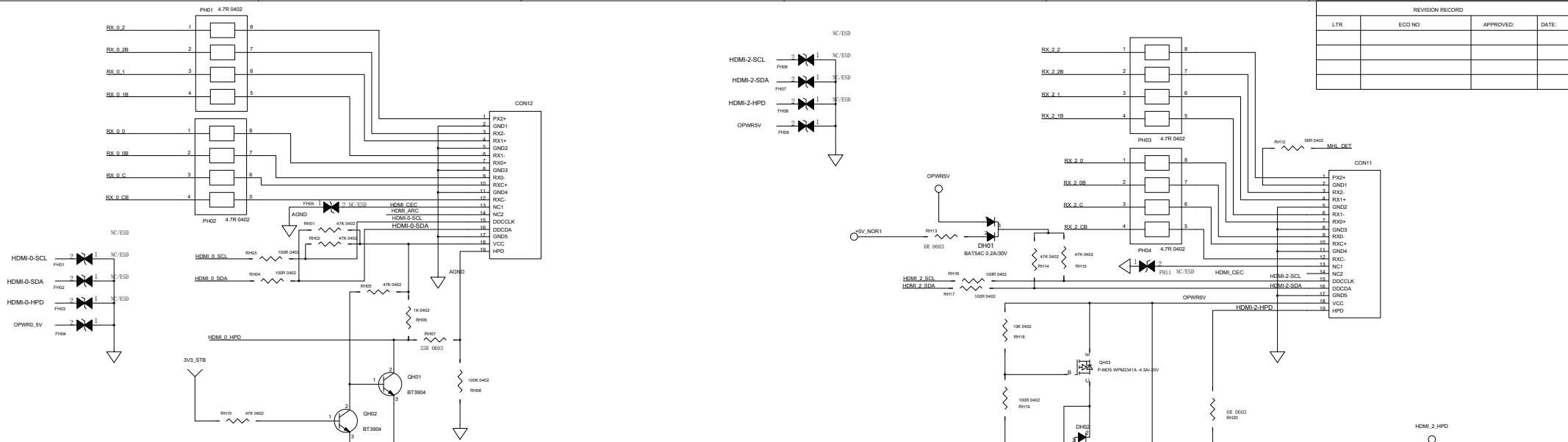

# HDMI

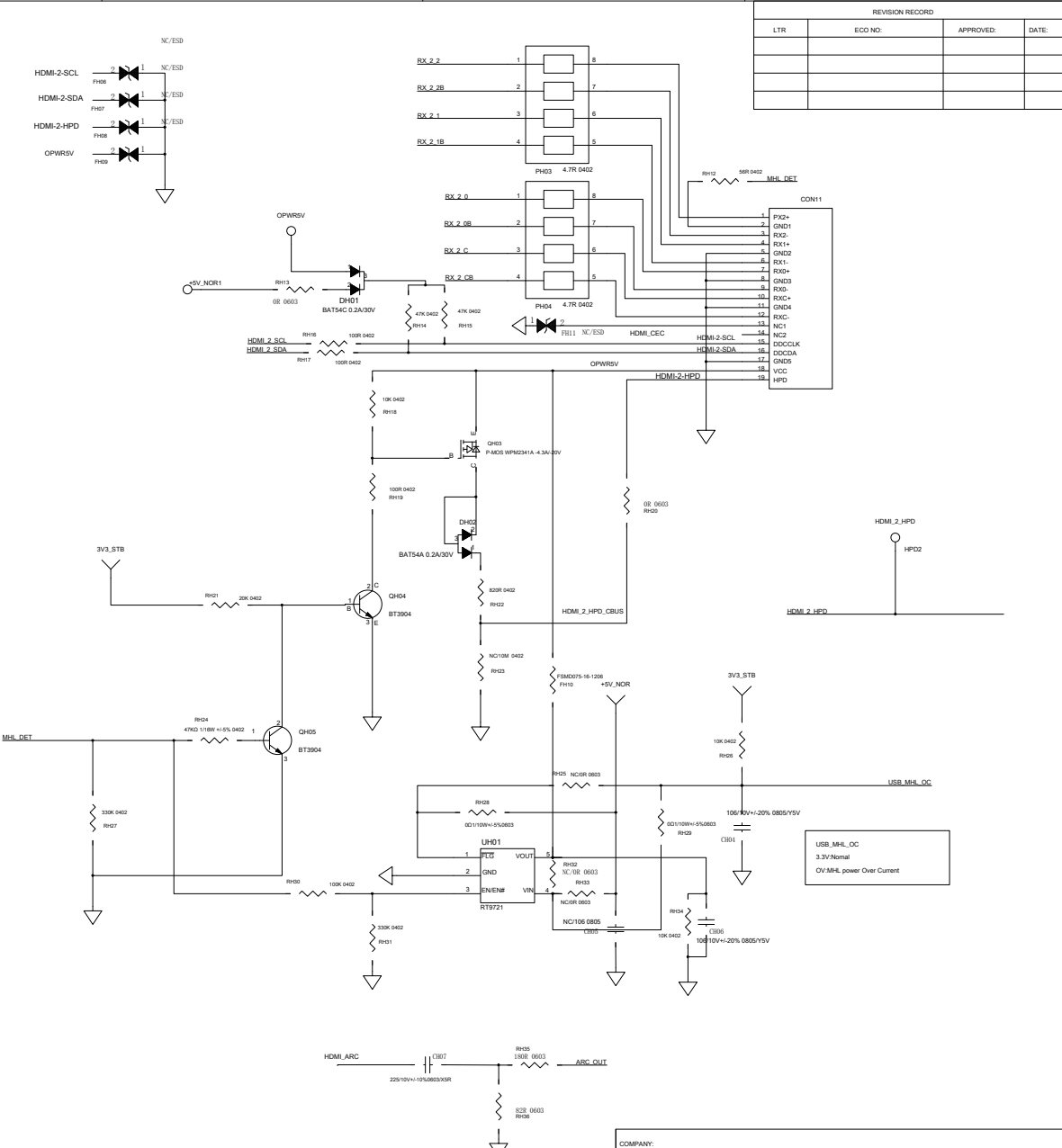
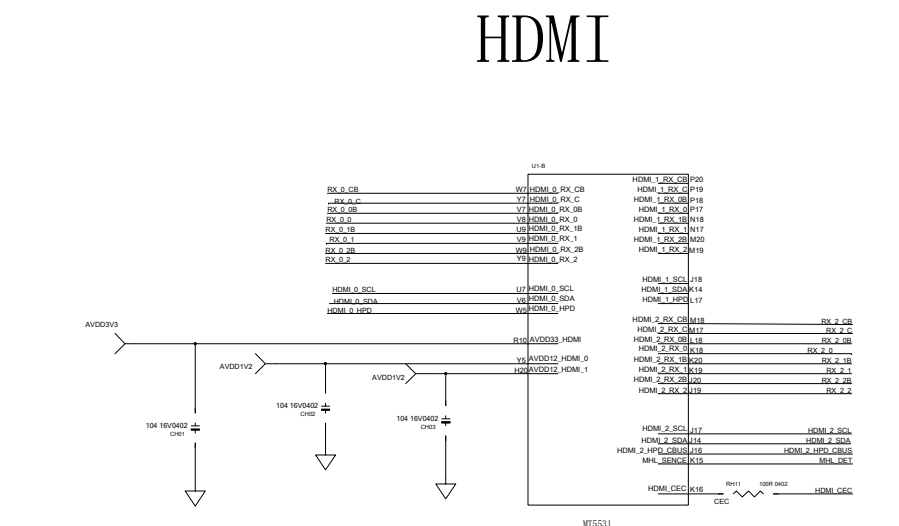

COMPANY:			
TITLE:			
DRAWN:	DATED:	CODE:	SIZE:
CHECKED:	DATED:	DRAWING NO.	
QUALITY CONTROL:	DATED:	REV:	
RELEASED:	DATED:	SCALE: 1:1	

6 5 4 3 2 1

REVISION RECORD			
LTR	ECO NO.	APPROVED:	DATE:

# AMPLIFIER

贴电感时, C152C164C156C171贴1uF  
贴磁珠时, C152C164C156C171贴1nF

# MUTE CONTROL

COMPANY:

TITLE:

DRAWN:	DATED:	CODE:	SIZE:	DRAWING NO.	REV:
CHECKED:	DATED:				
QUALITY CONTROL:	DATED:				
RELEASED:	DATED:				

A1

SCALE: SHEET: 040 12

6

5

4

3

2

1

REVISION RECORD			
LTR	ECO NO.	APPROVED:	DATE:

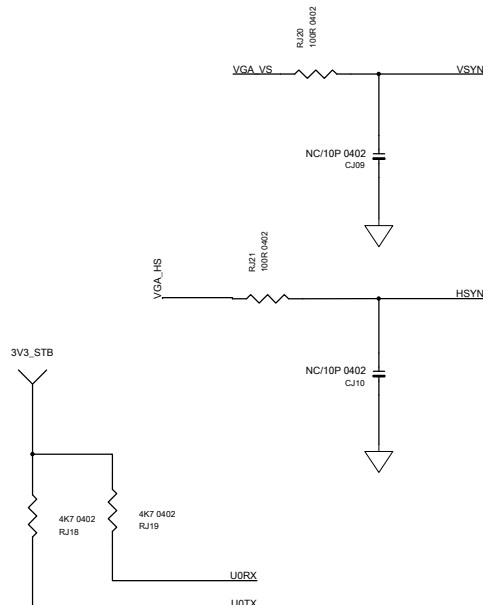
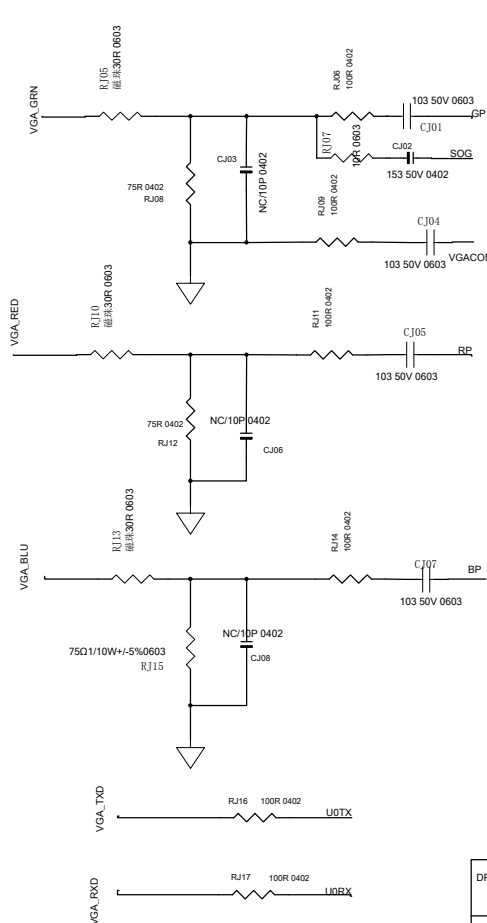
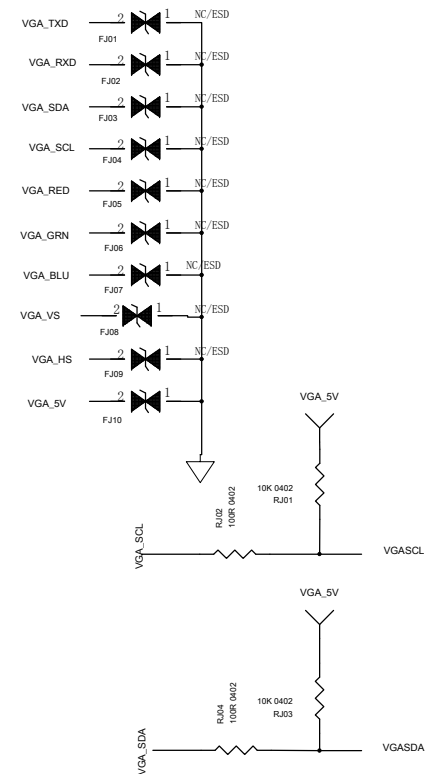
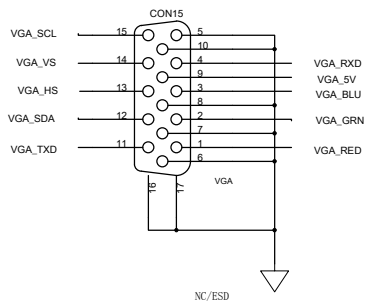

COMPANY:			
TITLE:			
CODE:	SIZE:	DRAWING NO:	REV:
<b>A1</b>			
SCALE:			SHEET: of 11 12

DRAWN:	DATED:
CHECKED:	DATED:
QUALITY CONTROL:	DATED:
RELEASED:	DATED:

D

D

C

C

B

B

A

A

REVISION RECORD			
LTR	ECO NO.	APPROVED:	DATE:

D

D

C

C

B

B

A

A

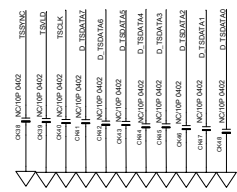
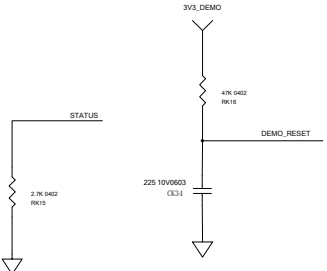
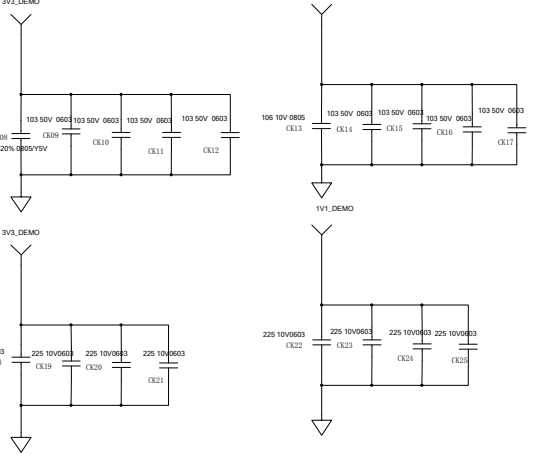
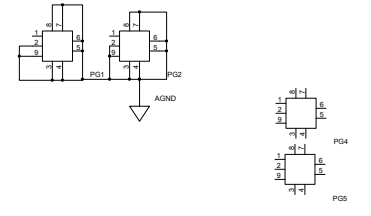
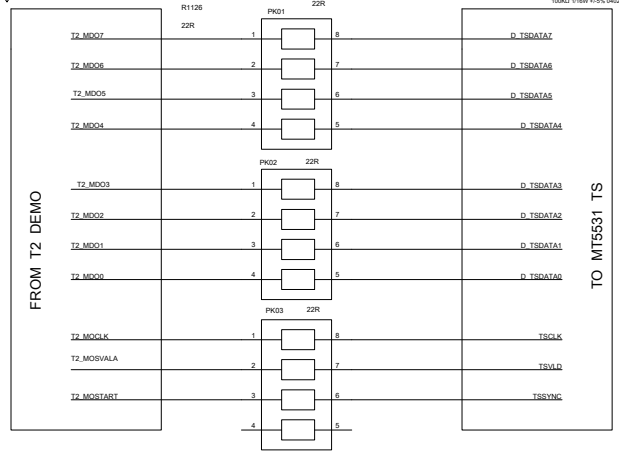
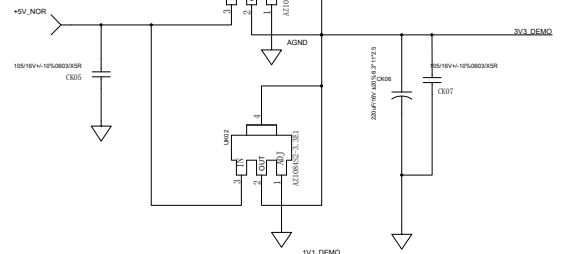
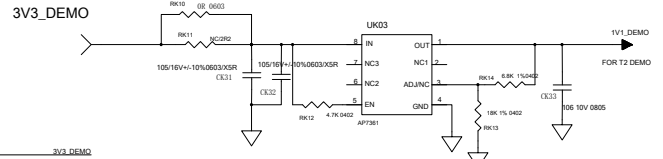
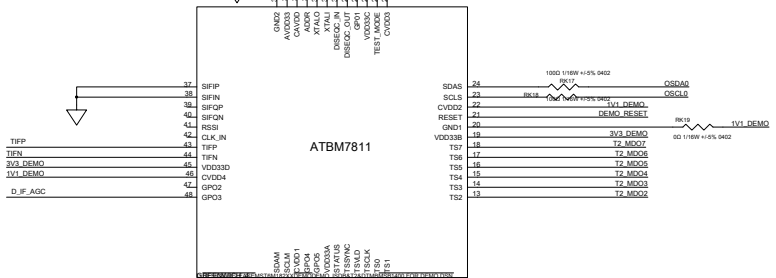
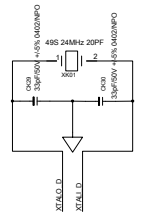
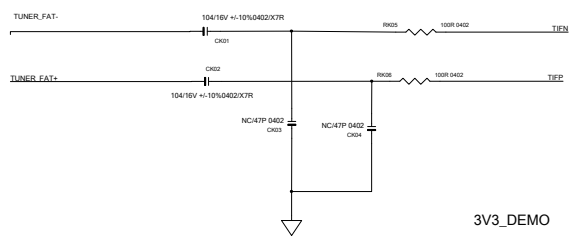
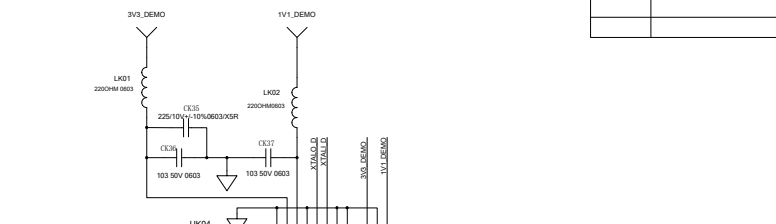
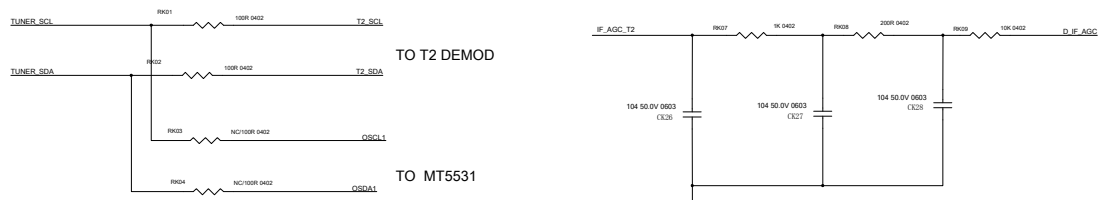

DRAWN:		DATED:		COMPANY:	
CHECKED:		DATED:		TITLE:	
QUALITY CONTROL:		DATED:		CODE:	SIZE:
RELEASED:		DATED:		DRAWING NO.:	
				REV.:	
				SCALE:	
				SHEET: 012 12	

A1