

13 SCHEMATIC DIAGRAM

13.1. DIGITAL BOARD

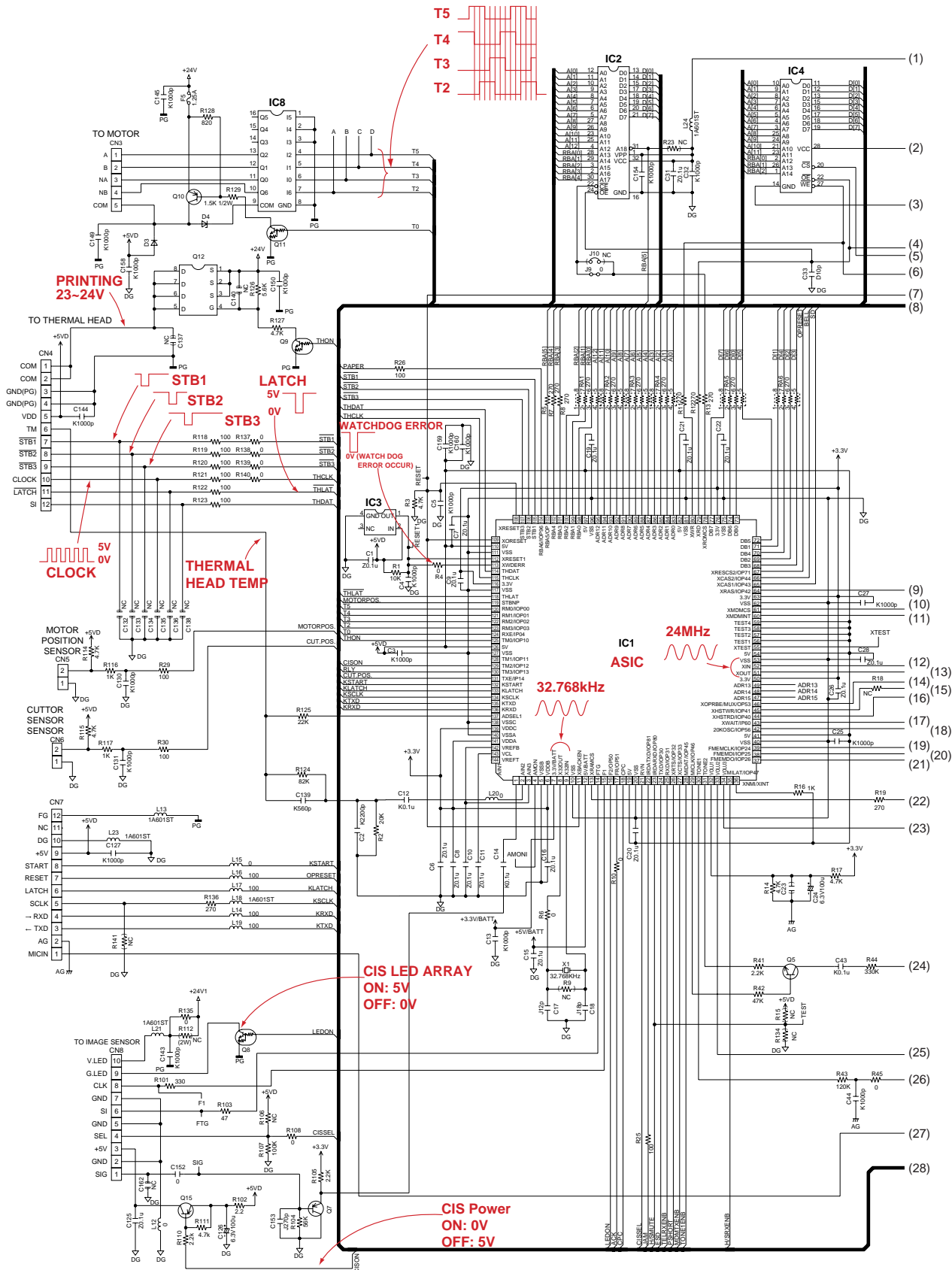

DIGITAL BOARD SCHEMATIC DIAGRAM
KX-FT74RU

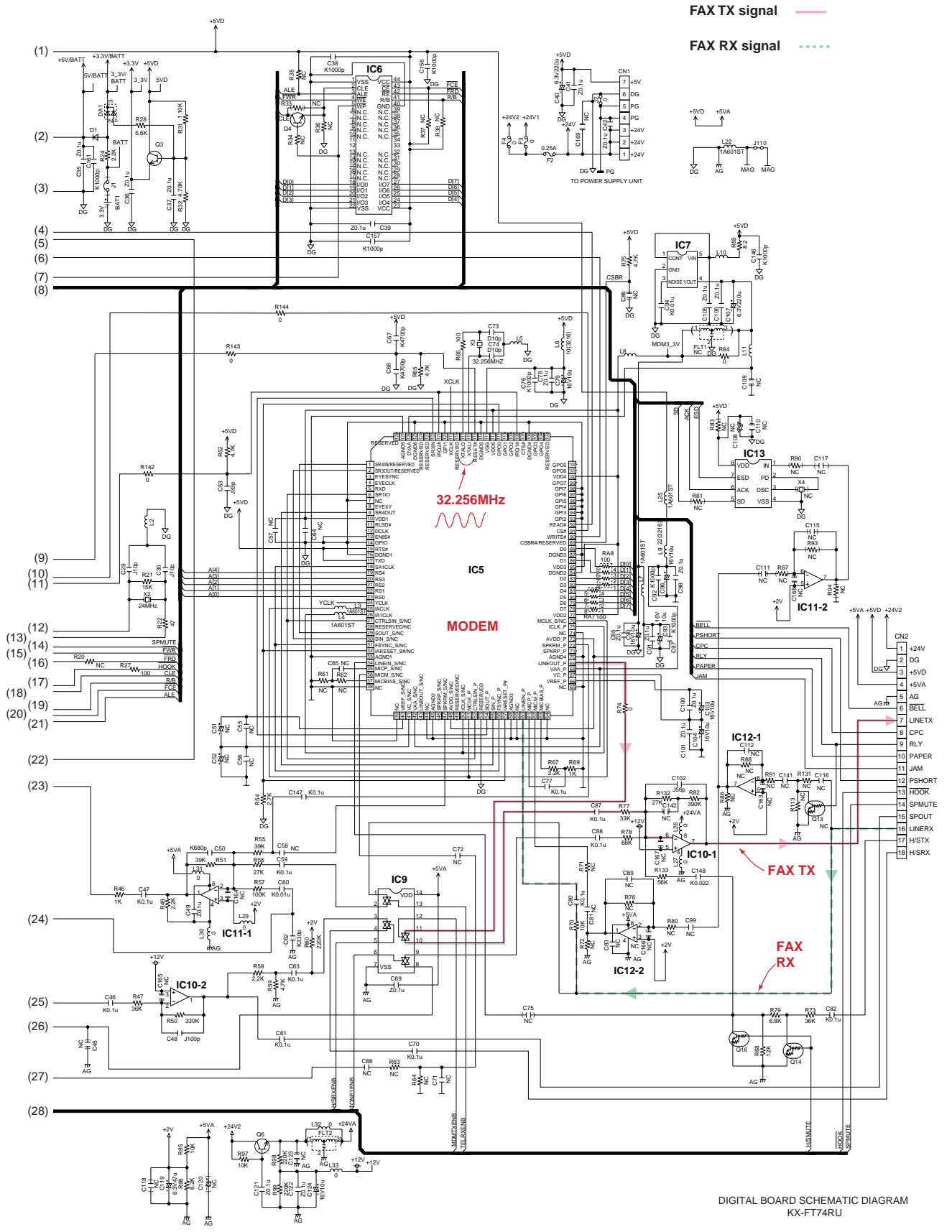

DIGITAL BOARD SCHEMATIC DIAGRAM
KX-FT74RU

13.2. ANALOG BOARD

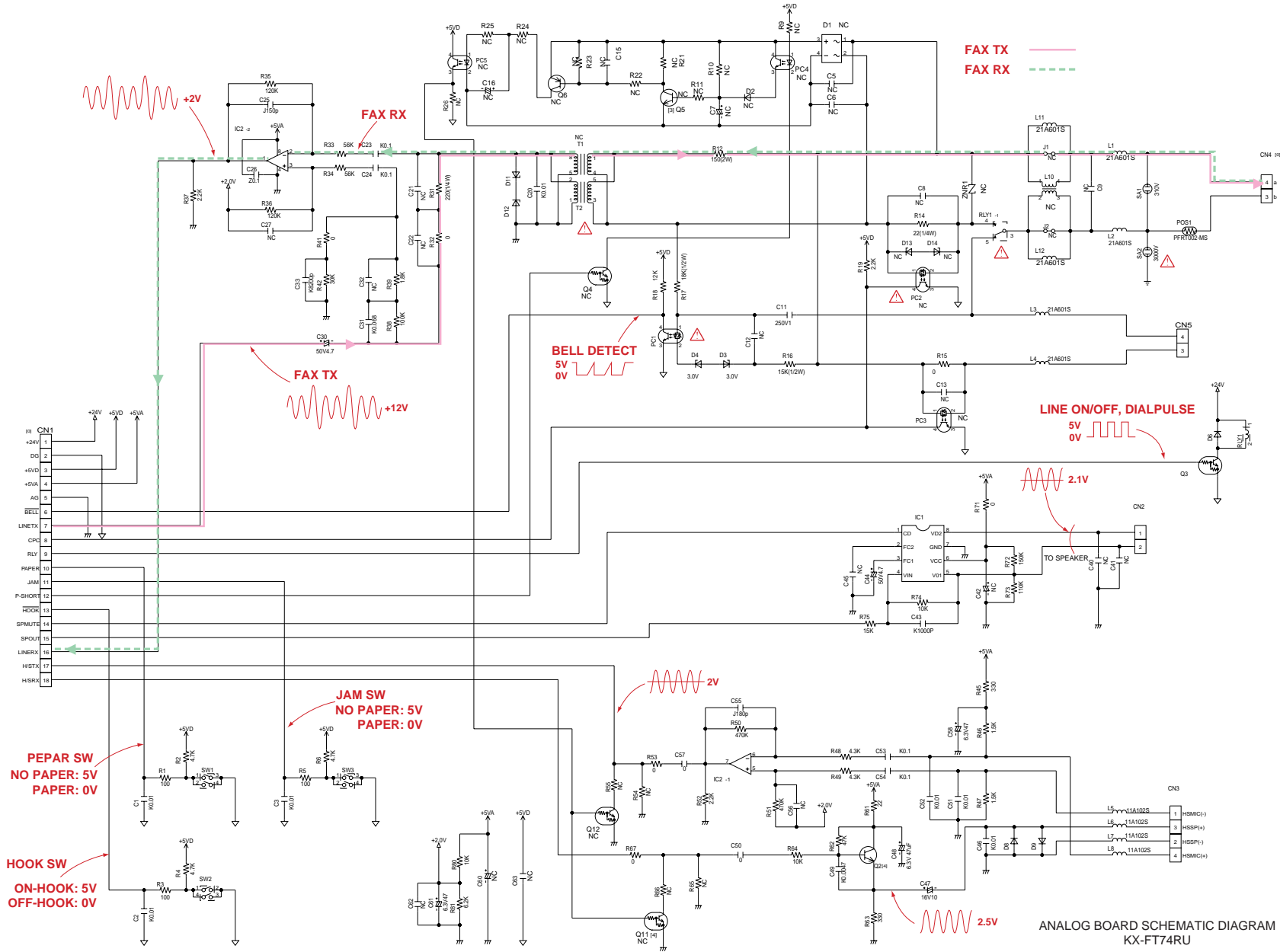

ANALOG BOARD SCHEMATIC DIAGRAM
KX-FT74RU

13.3. OPERATION BOARD

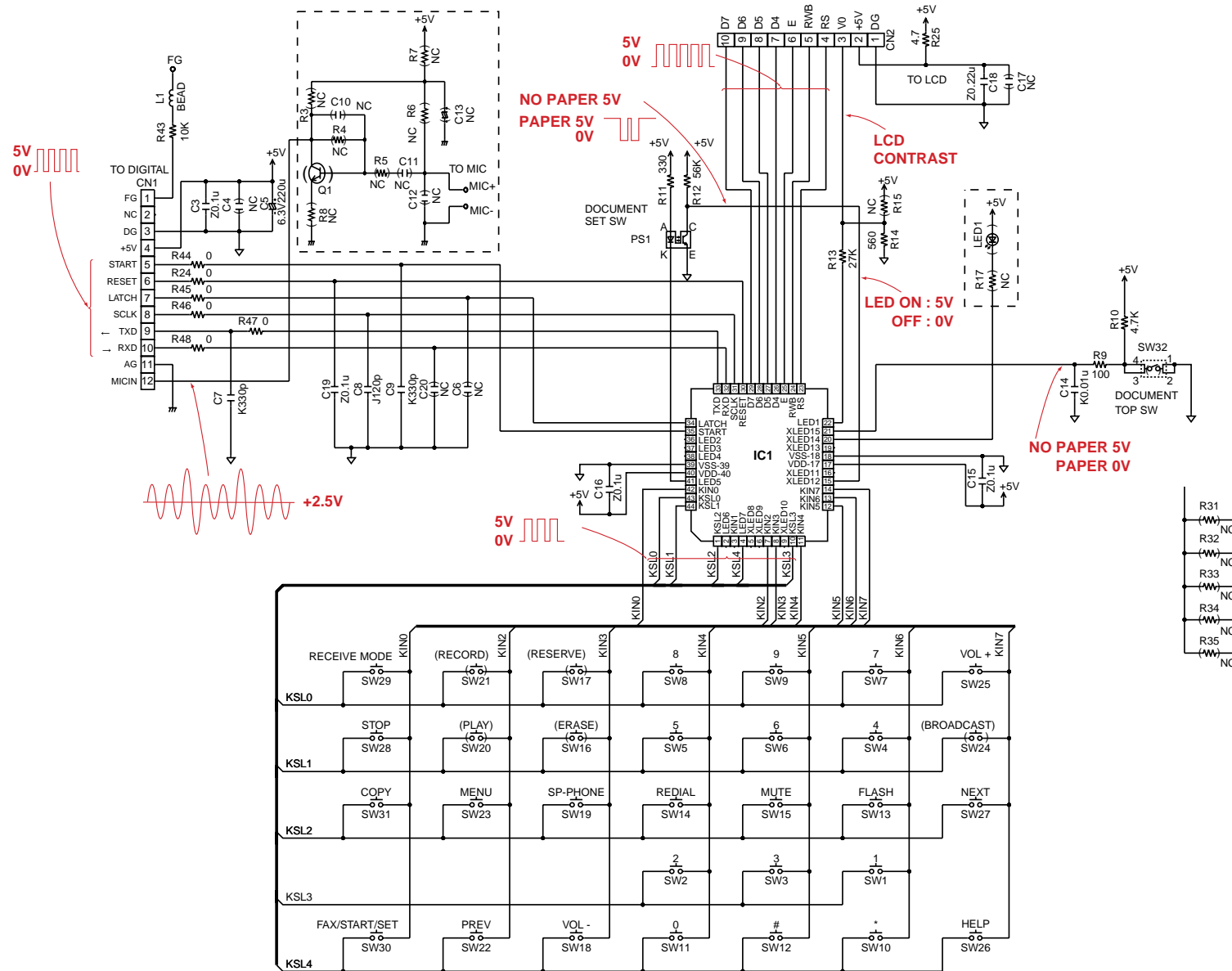

OPERATION BOARD SCHEMATIC DIAGRAM
KX-FT74RU

13.4. POWER SUPPLY BOARD

164

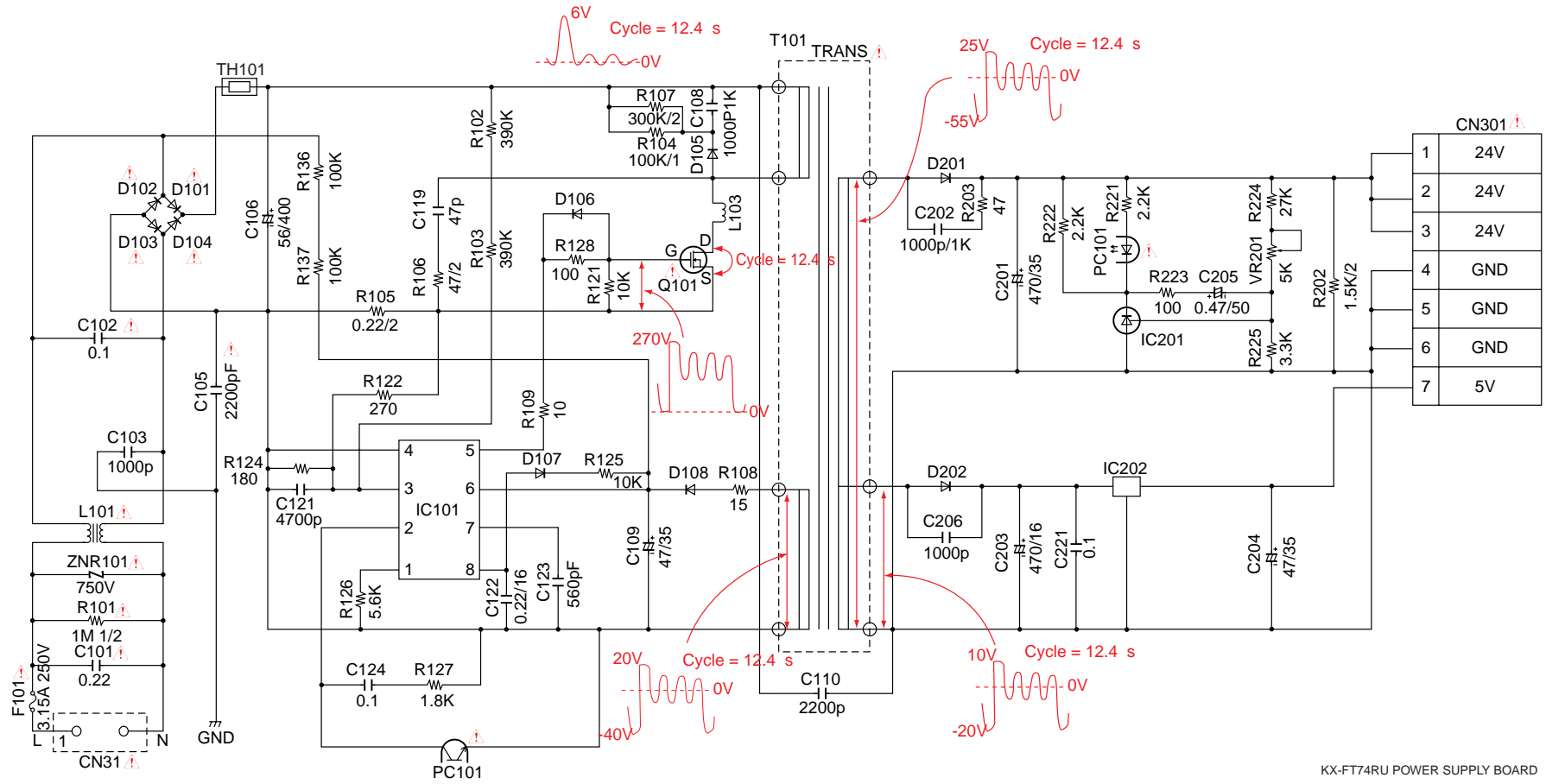

CN301	
1	24V
2	24V
3	24V
4	GND
5	GND
6	GND
7	5V

KX-FT4RU POWER SUPPLY BOARD