

37.2. Operation

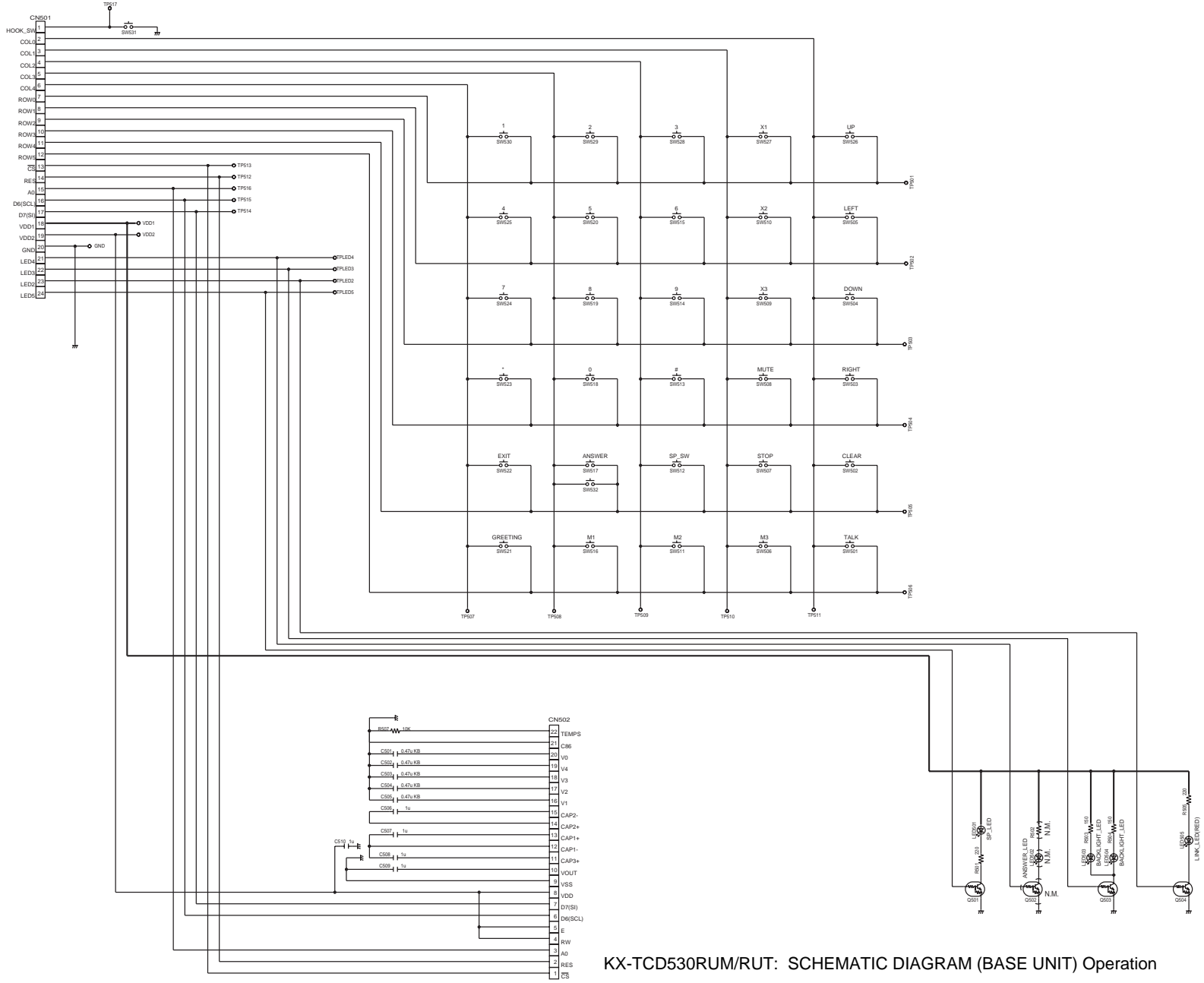

KX-TCDS30RUM/RUT: SCHEMATIC DIAGRAM (BASE UNIT) Operation

38 SCHEMATIC DIAGRAM (CORDLESS HANDSET)

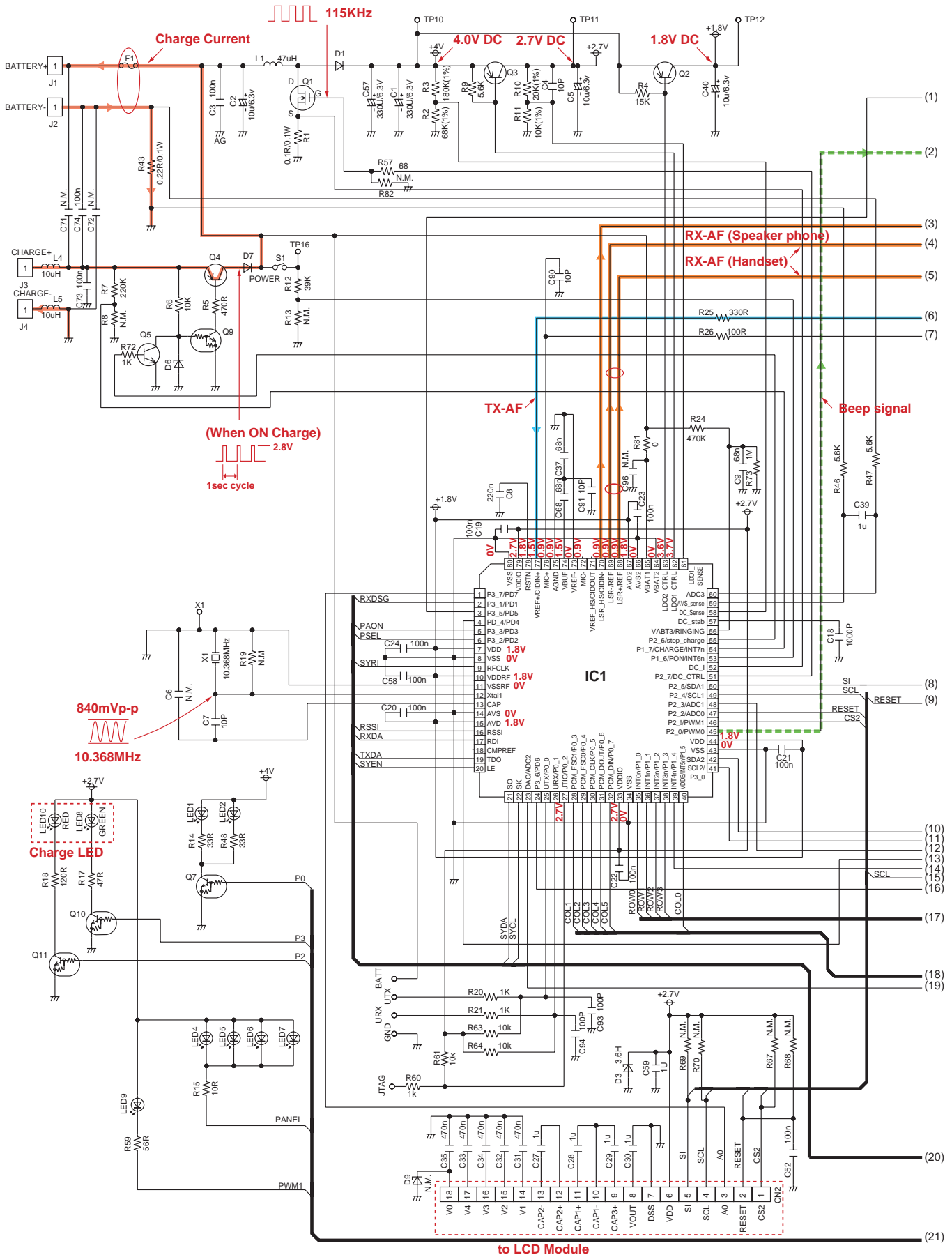

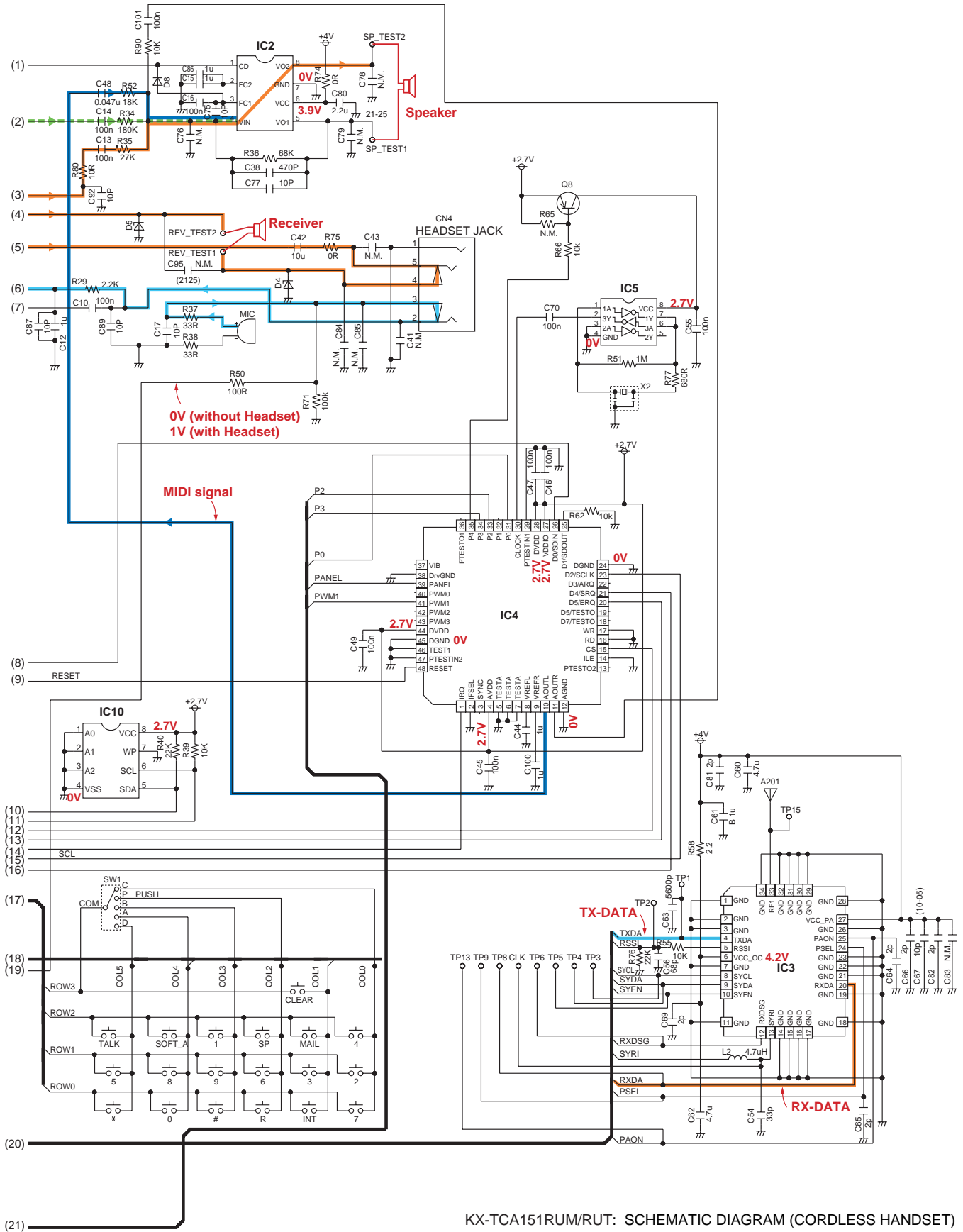

KX-TCA151RUM/RUT: SCHEMATIC DIAGRAM (CORDLESS HANDSET)

40 CIRCUIT BOARD (BASE UNIT)

40.1. Main

40.1.1. Component View

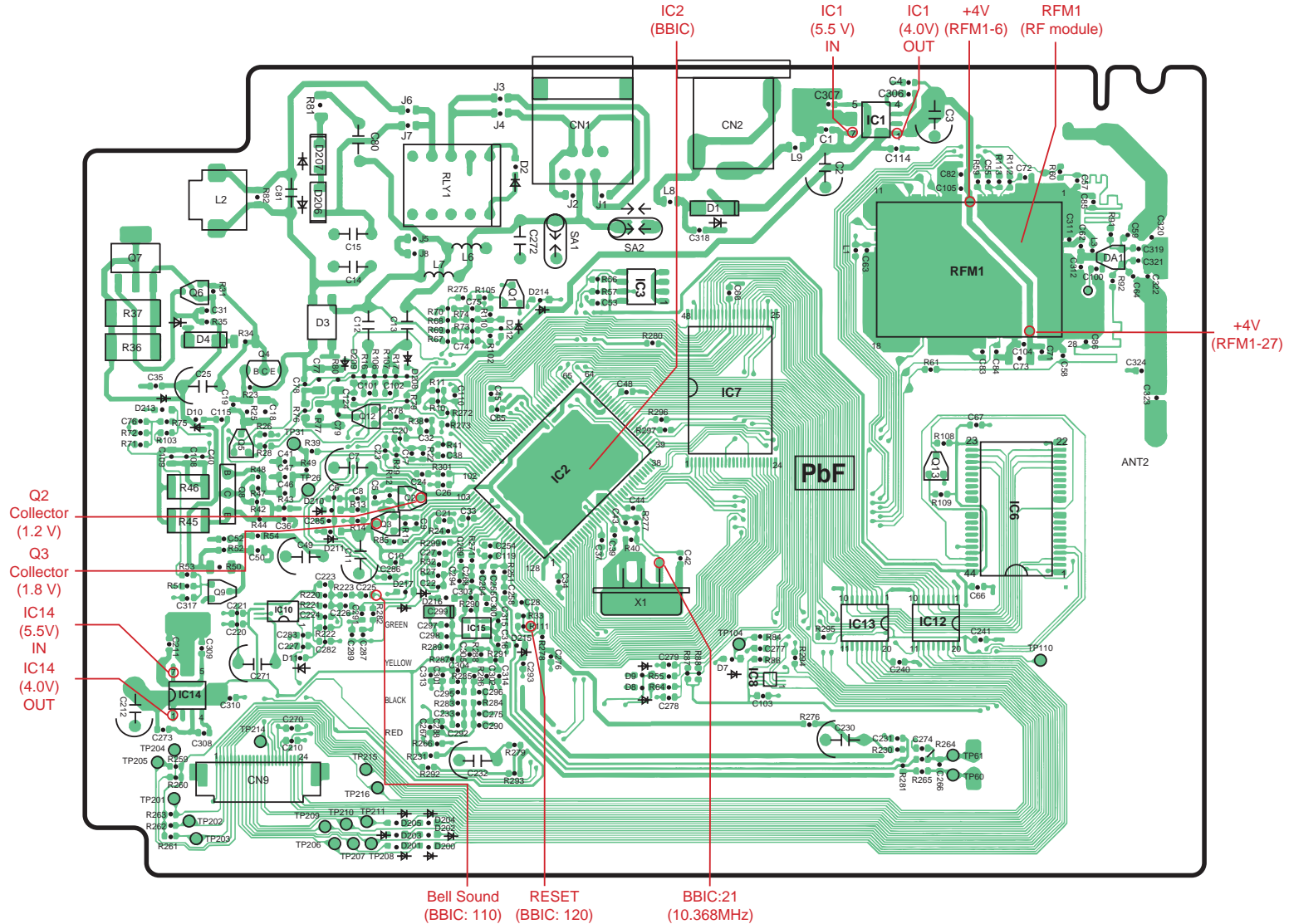

KX-TCDS30RUM/RUT CIRCUIT BOARD (BASE UNIT) Main (Component View)

40.1.2. Flow Solder Side View

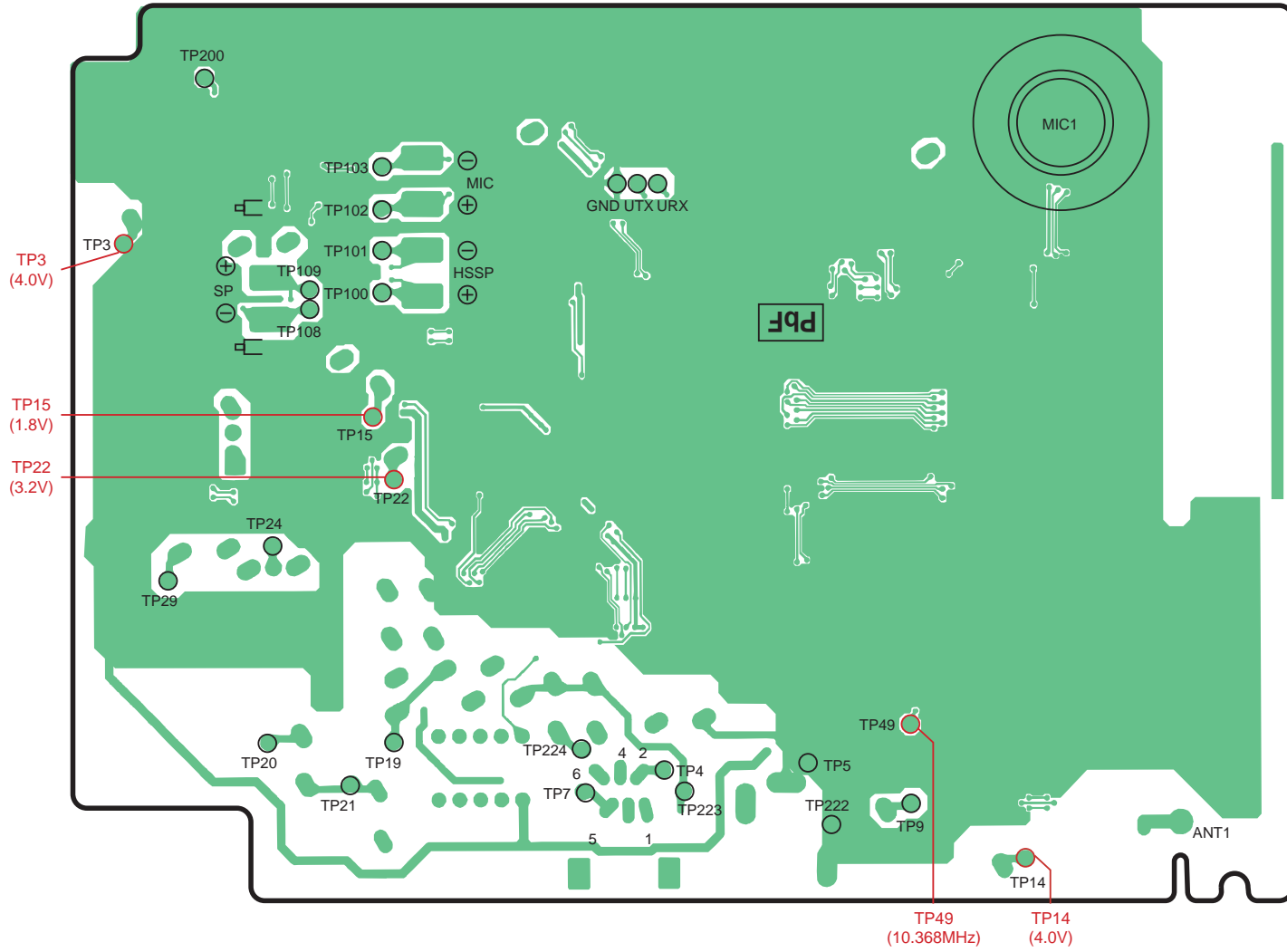

KX-TCDS30RUM/RUT CIRCUIT BOARD (BASE UNIT) Main (Flow Solder Side View)

40.2. Operation

40.2.1. Component View

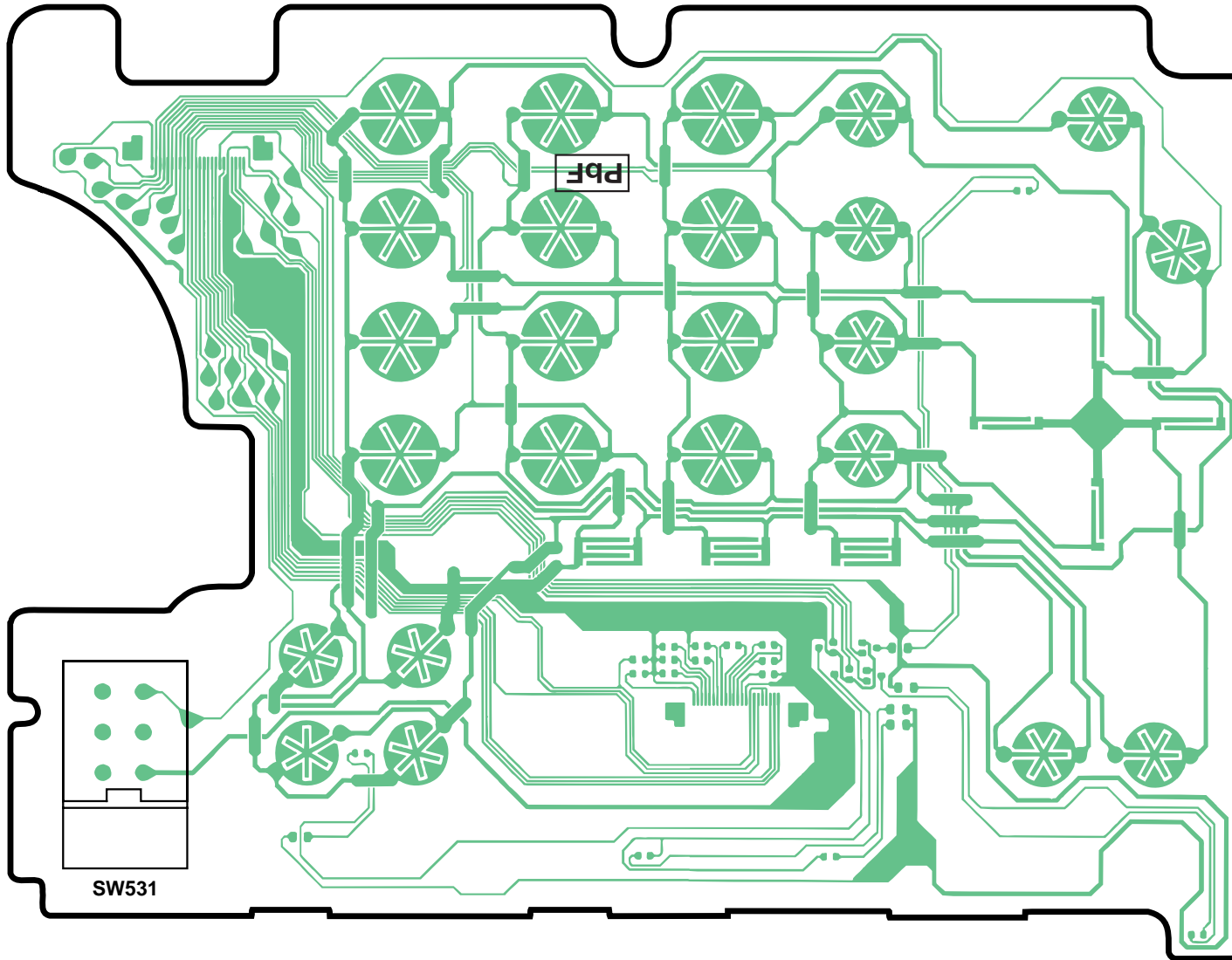

KX-TCD530RUM/RUT CIRCUIT BOARD (BASE UNIT) Operation (Component View)

40.2.2. Flow Solder Side View

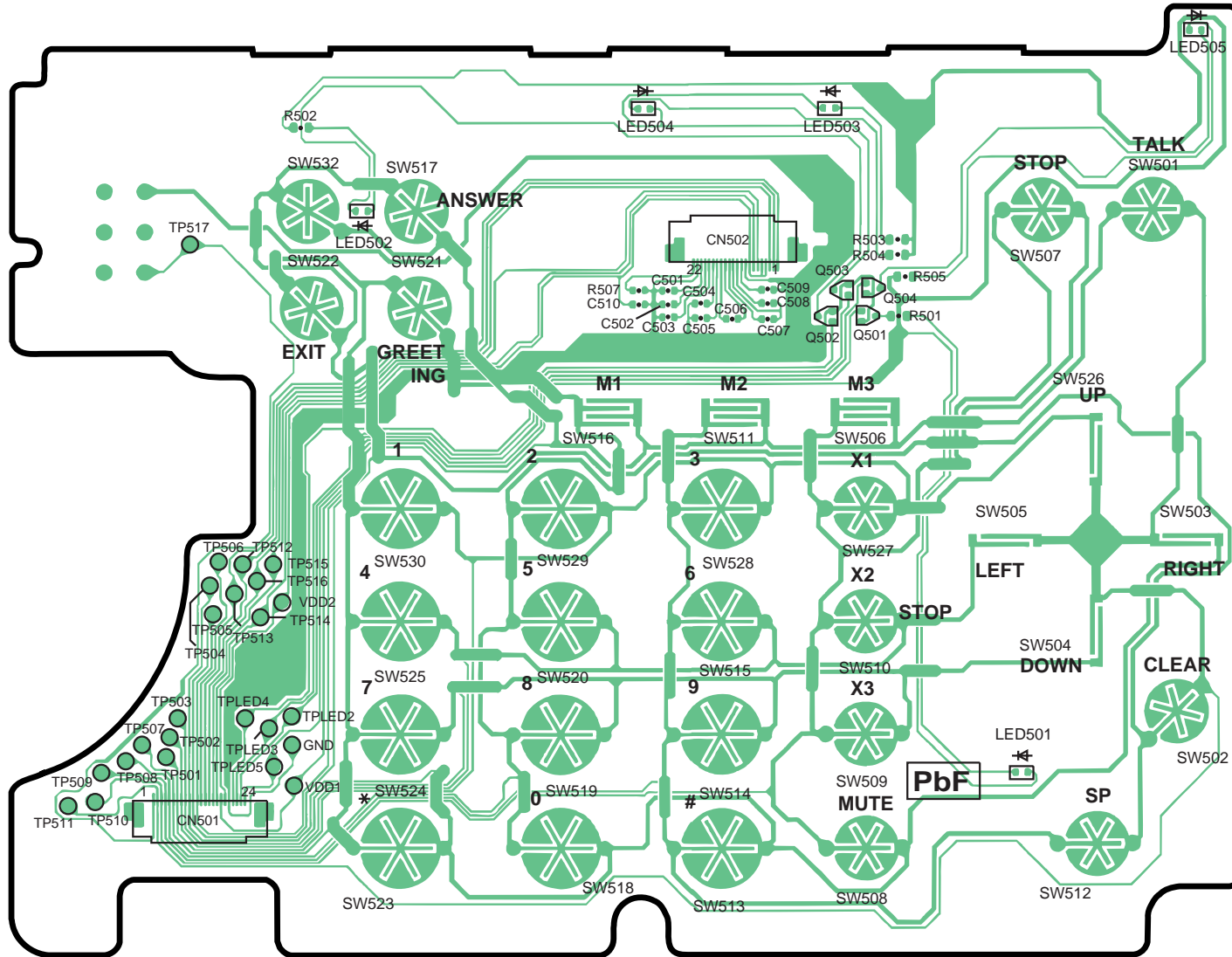

KX-TCDS30RUM/RUT CIRCUIT BOARD (BASE UNIT) Operation (Flow Solder Side View)

41.2. Flow Solder Side View

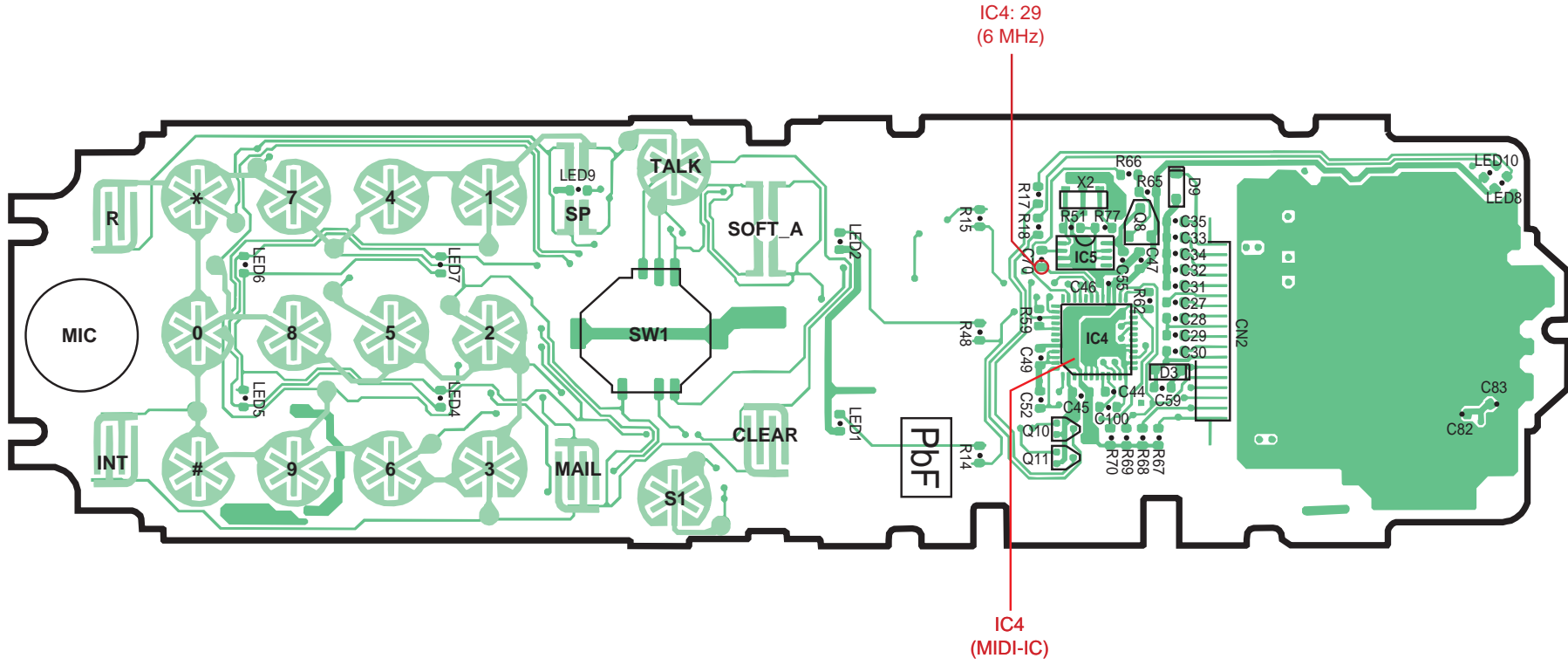

KX-TCA151RUM/RUT CIRCUIT BOARD (CORDLESS HANDSET) Flow Solder Side View