

FAN7554

Versatile PWM Controller

Features

- Current Mode Control
- Pulse by pulse current limiting
- Low external components
- Lowest cost SMPS solution
- Under-Voltage Lockout(UVLO): 9V/15V
- Stand-by Current: Typ. 100uA
- Power Saving Mode Current: Typ. 200uA
- Operating Current: Typ. 7mA
- Soft start
- On/Off control
- Over Load Protection(OLP)
- Over Voltage Protection(OVP)
- Over Current Protection(OCP)
- Over Current Limit(OCL)
- Operating Frequency up to 500kHz
- 1A Totem-pole Output Current

Applications

- Off-Line & DC-DC Converter

Description

FAN7554 is fixed frequency current-mode PWM controller. It is specially designed for off-line and DC-to-DC converter applications with minimal external components. These integrated circuits feature a trimmed oscillator for precise duty cycle control, a temperature compensated reference, high gain error amplifier, current sensing comparator, and a high current totempole output. Ideally suited for driving a power MOSFET. In addition to the general protection function of PWM IC, FAN7554 has various protection function such as Over Load Protection, Over Current Protection, Over Voltage Protection, which include Built-in auto-restart circuit, and Over Current Latch. Moreover, it incorporates on-off control circuit and soft start circuit. It also offer low power consumption in stand-by condition.

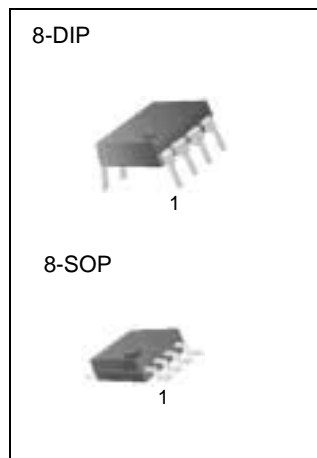

Internal Block Diagram

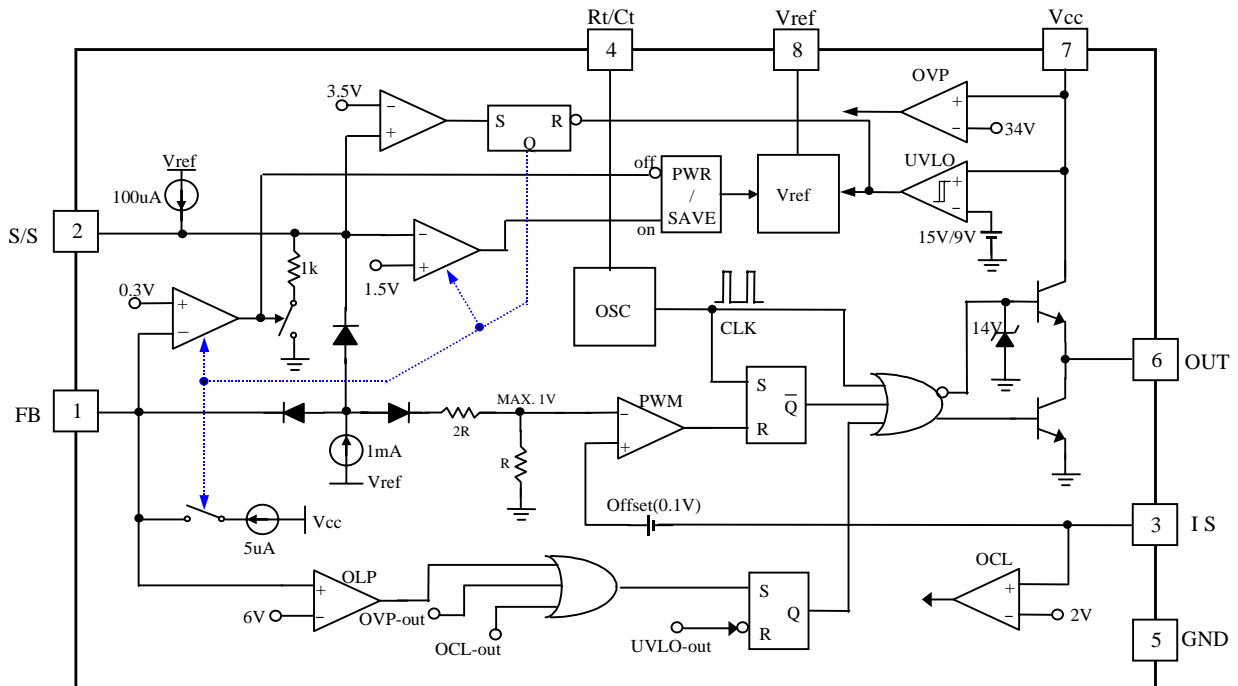

Absolute Maximum Ratings

($T_a = 25^\circ\text{C}$, unless otherwise specified)

Parameter	Symbol	Value	Unit
Supply Voltage	Vcc	30	V
Output Current	I _O	± 1	A
Input Voltage to FB Pin	V _{FB}	-0.3 to V _{SD}	V
Input Voltage to IS Pin	V _{IS}	-0.3 to V _{OC}	V
Power Dissipation	PD	1	W
Operating Temperature	T _{OPR}	-25 to +85	°C
Storage Temperature	T _{STG}	-55 to + 150	°C

Temperature Characteristics

($-25^\circ\text{C} \leq T_a \leq 85^\circ\text{C}$)

Parameter	Symbol	Value	Unit
Vref Temperature Stability	ΔV_{REF3}	± 0.5	%
Fosc Temperature Stability	ΔF_{OSC2}	± 5	%

PIN Array

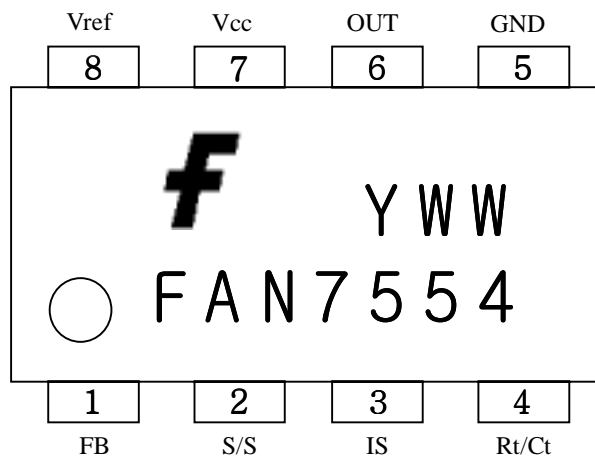

PIN Definitions

Pin Number	Pin Name	Pin Function Description
1	FB	Inverting(-) Input of PWM Comparator, On/Off Control & OLP Sensing Terminal.
2	S/S	Soft Start
3	IS	Non-Inverting(+) Input of PWM Comparator, OCL Sensing Terminal
4	Rt/Ct	Oscillator Time Constant(Rt/Ct)
5	GND	Ground
6	OUT	Output of gate Driver
7	Vcc	Power Supply
8	Vref	Output of 5V Reference(Max. 100mA)

Electrical Characteristics

(Refer to circuit Ta = 25°C, Vcc=16V, Rt=10kΩ, Ct=3.3nF unless otherwise specified)

Parameter	Symbol	Conditions	Min.	Typ.	Max.	Unit
< REFERENCE SECTION >						
Reference Output Voltage	VREF	Tj=25°C, Iref=1mA	4.90	5.00	5.10	V
Line Regulation	ΔVREF1	Vcc=12V~25V	-	6	20	mV
Load Regulation	ΔVREF2	Iref=1mA~20mA	-	6	25	mV
Short Circuit Output Current	ISC	Tj=25°C	-	0.1	0.18	A
< OSCILLATOR SECTION >						
Oscillation Frequency	FOSC	Tj=25°C	45	50	55	kHz
Frequency Change with Vcc	ΔFOSC1	Vcc=12V~25V	-	0.05	1.0	%
Ramp High Voltage	VRH	-	-	2.8	-	V
Ramp Low Voltage	VRL	-	-	1.2	-	V
< PWM SECTION >						
Sense Threshold Voltage(Vocp)	VTH(IS)	VFB = 5V	0.8	1.0	1.2	V
Feedback Threshold Voltage	VTH(FB)	VIS = 0V	0.2	0.3	0.4	V
Feedback Source Current	IFB	VFB = 0V, VS/S = 5V	-	1.0	-	mA
Max. Duty Cycle	D(MAX)	-	92	95	98	%
Min. Duty Cycle	D(MIN)	-	-	-	0	%
< PROTECTION SECTION >						
Shutdown Delay Current	ISD	4V ≤ VFB ≤ VSD	3.5	5	6.5	uA
Shutdown Feedback Voltage	VSD	VFB > 5V	5.4	6	6.6	V
Over Current Latch Protection	VOC	VIS > 1.5V, ton > 500nS	1.6	2	2.4	V
Over Voltage Protection	VOVP	-	30	34	38	V
< ON/OFF CONTROL SECTION >						
Off Mode Sink Current	ISINK	VFB < VTH(FB), VS/S = 5V	-	4	-	mA
Off Threshold Voltage	VOFF	VFB < VTH(FB)	1.2	1.5	1.8	V
< SOFT-START SECTION >						
Soft Start Current	IS/S	VFB = 5V, VS/S = 0V	-	1.1	-	mA
Soft Start Limit Voltage	VLIM(S/S)	Vcc = 16V	-	5.2	-	V
<OUTPUT SECTION>						
Low Output Voltage1	VOL1	Io = 50mA	-	0.15	0.4	V
High Output Voltage1	VOH1	Io = 50mA	13	15	17	V
Low Output Voltage2	VOL2	Io = 200mA	-	1.5	2.5	V
High Output Voltage2	VOH2	Vcc=18V, Io=200mA	12	14	16	V
Rising Time	tR	Tj=25°C, CL = 1nF	-	80	-	nS
Falling Time	tF	Tj=25°C, CL = 1nF	-	40	-	nS
<UVLO SECTION>						
Start Threshold Voltage	VTH(ST)	-	13.2	15	16.2	V
Min. Operating Voltage	VOPR(M)	-	8.2	9	10.2	V

Electrical Characteristics (Continued)

(Refer to circuit $T_a = 25^{\circ}\text{C}$, $V_{cc}=16\text{V}$, $R_t=10\text{k}\Omega$, $C_t=3.3\text{nF}$ unless otherwise specified)

Parameter	Symbol	Conditions	Min.	Typ.	Max.	Unit
<TOTAL STANDBY CURRENT SECTION>						
Start-up Current	I _{ST}	$V_{cc} = 14\text{V}$	-	0.1	0.2	mA
Operating Supply Current	I _{OP}	$V_{cc} \leq 30\text{V}$	-	7	10	mA
Off State Current	I _{OFF}	$V_{cc}=14\text{V}, V_{FB}<V_{TH(FB)}, V_{S/S}<V_{OF}$	-	0.2	0.4	mA

Typical Performance Characteristics

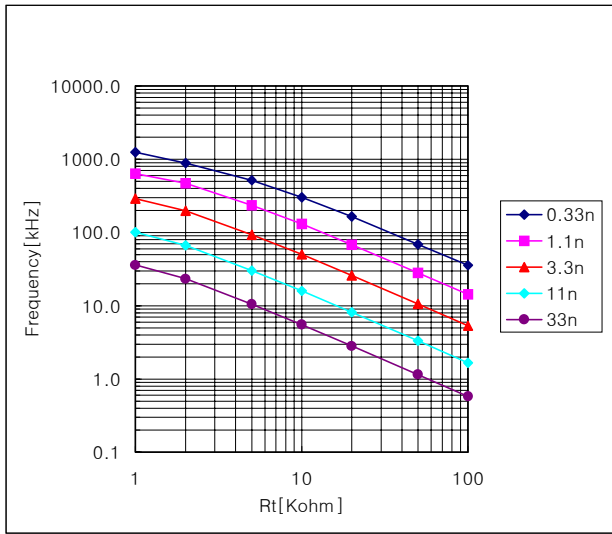

Figure 1. Rt vs Frequency

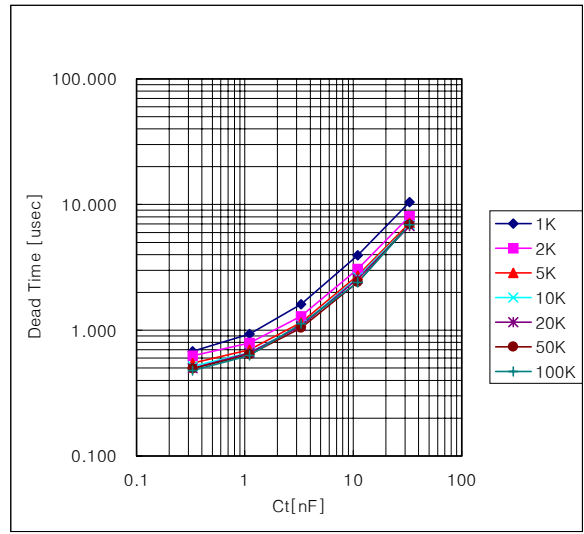

Figure 2. Ct vs Dead Time

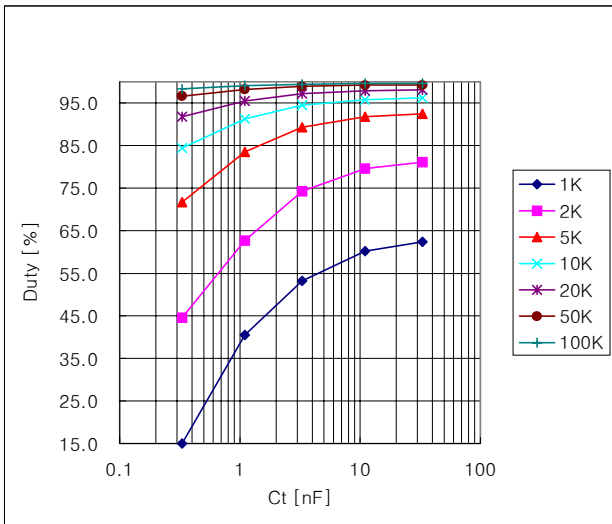

Figure 3. Ct vs Duty

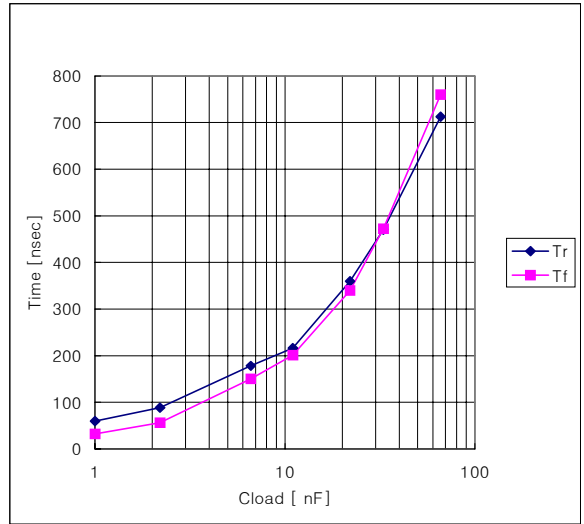

Figure 4. Cloud vs Tr & Tf

Typical Performance Characteristics(Continued)

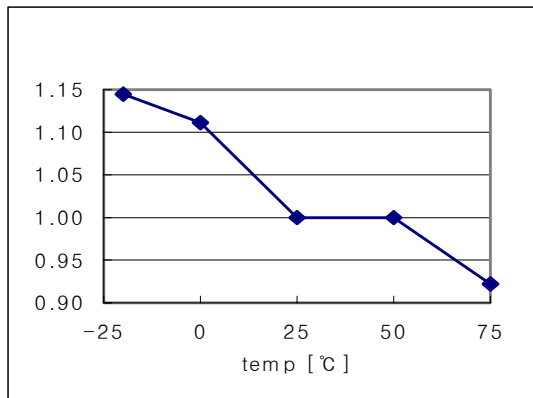

Figure 1. Temperature vs Ist (at 25°C)

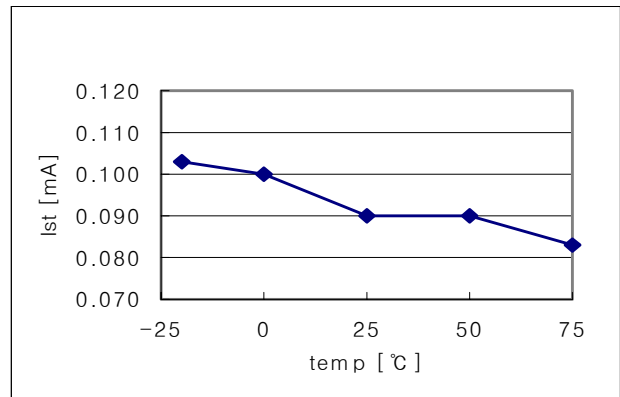

Figure 2. Temperature vs Ist

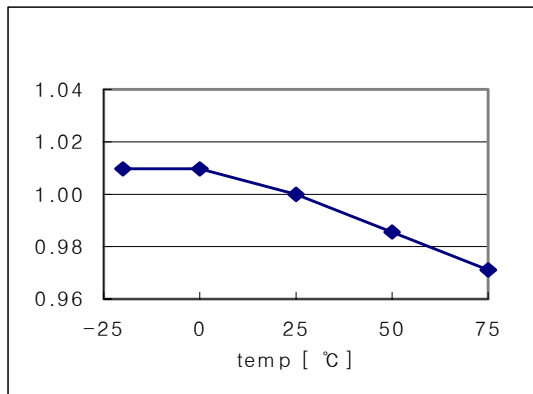

Figure 3. Temperature vs Iop (at 25°C)

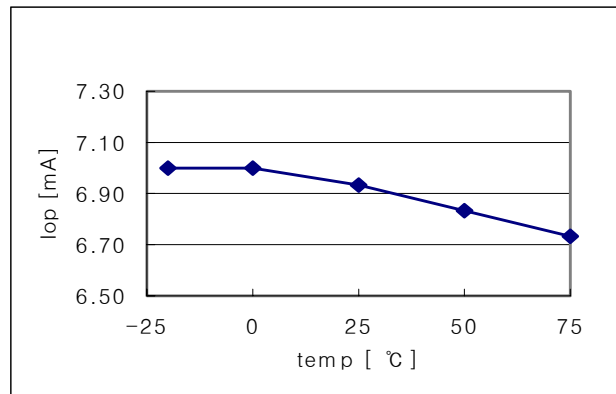

Figure 4. Temperature vs Iop

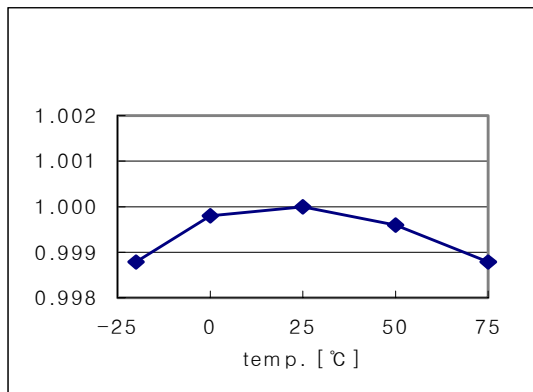

Figure 5. Temperature vs Vref (at 25°C)

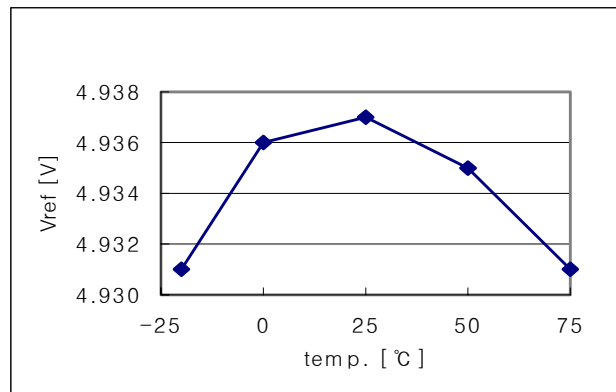

Figure 6. Temperature vs Vref

Typical Performance Characteristics(Continued)

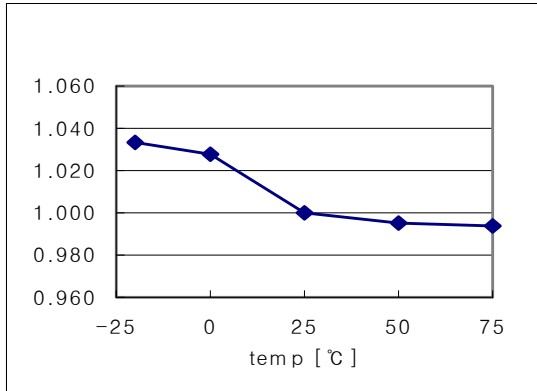

Figure 7. Temperature vs Fosc(at 25°C)

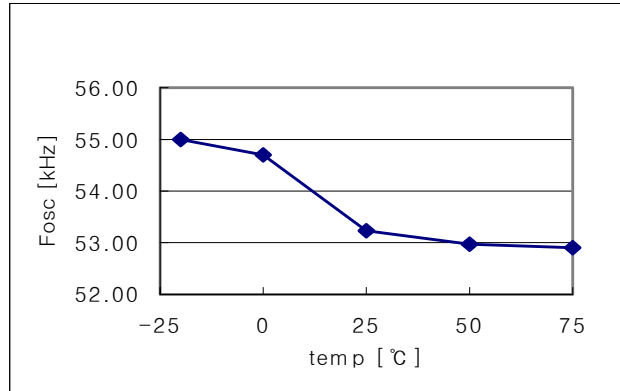

Figure 8. Temperature vs Fosc

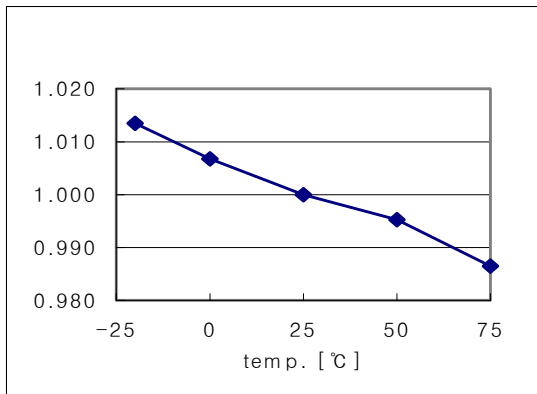

Figure 9. Temperature vs Norm Alized Vth(st)

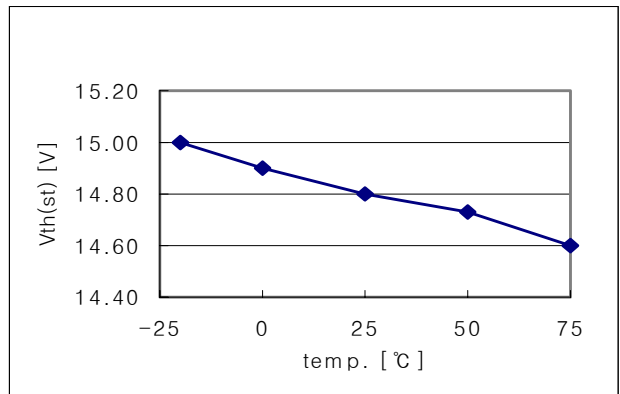

Figure 10. Temperature vs Vth(st)

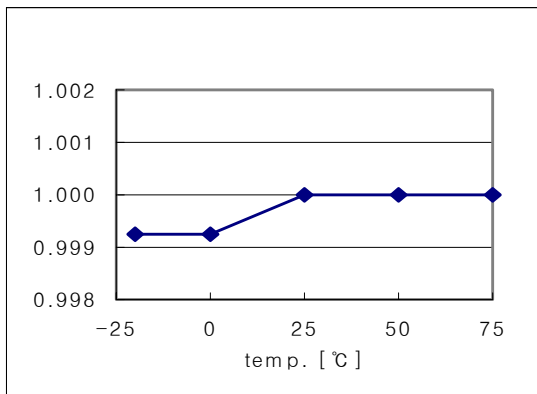

Figure 11. Temperature vs Alized Vopr(min)

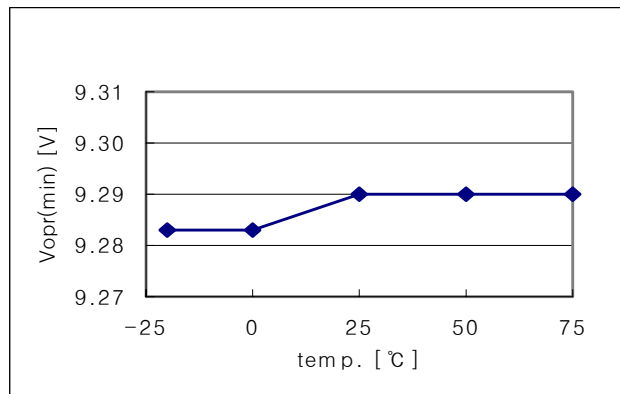

Figure 12. Temperature vs Vopr(min)

Operation Description

FAN7554 has all the basic features of the current mode SMPS control IC. Furthermore, as a PWM (Pulse Width Modulation) control IC, FAN7554 modulates the pulse width by comparing the input current sense voltage level to the feedback voltage level. Its basic configuration includes a UVLO with 6V hysteresis, 5V bandgap reference, low start-up current, oscillator that can oscillate up to 500KHz depending on R_t/C_t (connected externally), PWM logic circuit, MOSFET gate drive, feedback circuit that has the current source and soft start function. Its protection circuit has delayed shutdown and over current shutdown functions. Of the two protection functions, the delayed shutdown forces the IC to charge the feedback capacitor C_{fb} with current source in the IC for the additional delay time if there is an error or overload from a system feedback loop failure or if there is a transient state. Then it forces a system shutdown after a specified time. Then a MOSFET breakdown etc. causes over current to flow. The over current shutdown is the protection function that stops all of control operations to protect the IC and system. As an Auto-restart circuit, the shutdown circuit resets when V_{cc} becomes less than the under voltage.

Start-Up

Start-Up circuit drives the FAN7554 IC using the low start up current. It is made up of the Under Voltage Lock Out (UVLO), the protection for low voltage conditions, and a 5V reference (V_{ref}), which supplies Bias voltage to the Control Circuit, after Start Threshold Voltage. The Starting voltage of the UVLO is 15V, and the minimum voltage after turn on is 9V. It has a 6V hysteresis. The minimum operating current for start up threshold is typically 100uA, and this can minimize the power loss from the starting resistor. V_{ref} is designed with the bandgap reference circuit with its superior temperature characteristics and supplies power to all FAN7554 circuits and R_t/C_t , with the exceptions of the ULVO circuit and ON/OFF control circuit. Furthermore, as for the Good Logic block, it either makes the output drive in low or discharges the soft start capacitor or feedback capacitor.

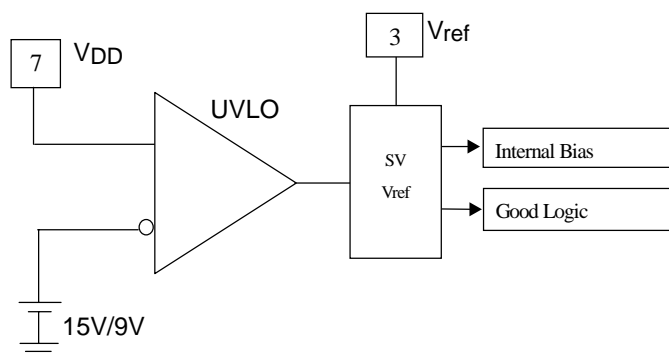

Figure 1. Low Current Start-Up & Bandgap Reference Circuit

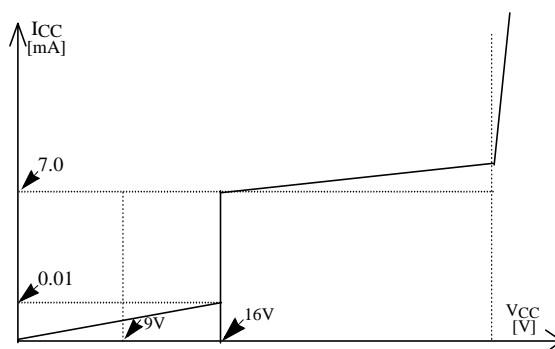

Figure 2. Start-Up & Circuit Characteristics

Soft Start

The SMPS output load usually contains a capacitive load component. During initial start up, the output voltage increases at a fixed time constant because of this component. If the feedback loop, which controls the output voltage, was to start without the soft start circuit, the feedback loop would appear to be open during initial startup, and This would drive the voltage in feedback pin up to 1V as a maximum voltage.

During this time, the peak value of the drain current would stay at the maximum value, and the maximum power would be delivered to the secondary load side from the start. If maximum power was supplied to the secondary side at start for a fixed time in the SMPS, this can put severe stress on the entire circuit to prevent such a case, the soft start function is needed and included in this control system. At start up, the soft start capacitor C_s is charged with 1mA and 100uA current sources.

The voltage of the inverting terminal of the PWM comparator increases to 1/3 of the C_s voltage at a fixed time constant. Subsequently, the drain peak current is limited by the gradual increase in the C_s voltage and this causes the output voltage to increase smoothly. When the C_s voltage becomes greater than 3V, diode D_s turns off and the inverting terminal voltage becomes no longer a function of the C_s voltage but of the feedback signal. Then, C_s voltage charges to 5V using 100uA. The soft start capacitor C_s is discharged when the UVLO Good Logic starts, so soft start is repeated at re-start.

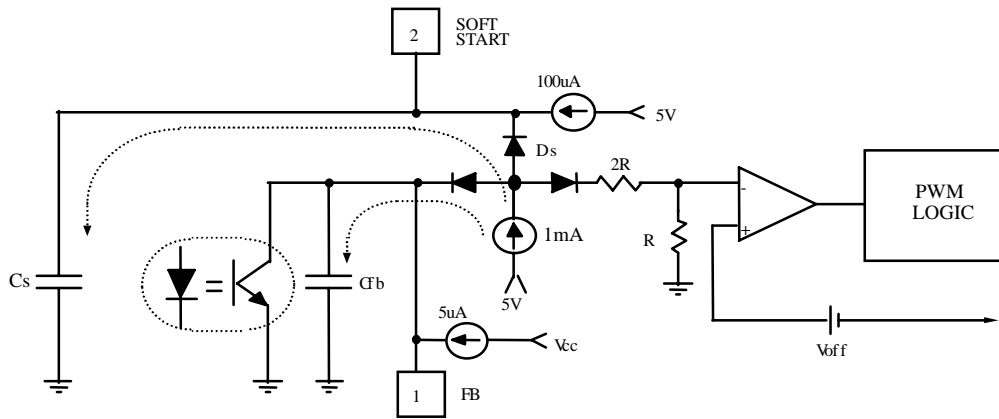

Figure 3. Soft Start Circuit & Circuit Flow

Oscillator

The oscillator frequency is programmed by values selected for timing components R_t and C_t . Capacitor C_t is charged to almost 2.8V through resistor R_t from the 5V reference and discharged to 1.2V by the current sink. The oscillator generates the clock signal during the timing capacitor's C_t discharge. The gate drive output becomes low during the clock time. R_t and C_t selections determines the oscillator frequency and maximum duty cycle. Charge and discharge times can be calculated through the equations below.

$$\text{Charging time : } t_c = 0.55 \times R_t \times C_t$$

$$\text{Discharging time : } t_d = R_t \times C_t \times \ln[(0.0063 \times R_t - 2.7) / (0.0063 \times R_t - 4.0)]$$

$$\text{where the oscillator frequency : } f_{osc} = (t_c + t_d)^{-1}$$

$$\text{When } R_t > 5K\Omega, f_{osc} = 1 / (0.55 \times R_t \times C_t) = 1.8 / (R_t \times C_t)$$

FAN7554 has almost 100% maximum duty cycle. This duty cycle clamp is useful generally in the flyback or forward converter. To optimize the device's performance, the external clock signal blanks the output to low during deadtime. This limits the maximum duty cycle.

$$D_{max} = t_c / (t_c + t_d)$$

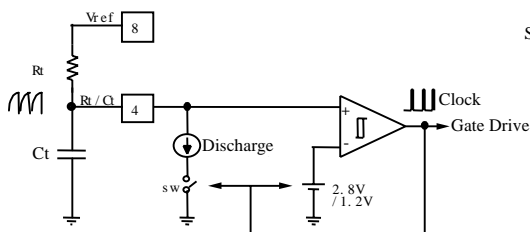

Figure 4. Oscillator Circuit

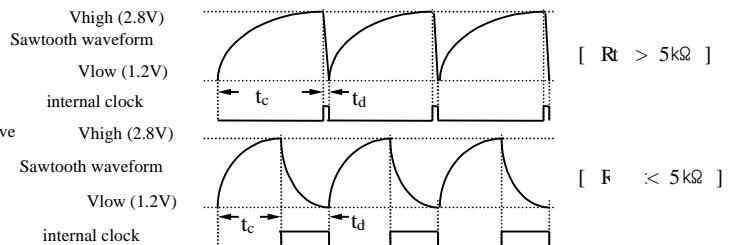

Figure 5. Sawtooth & Clock Waveform

Feedback

The feedback section can control the feedback voltage and execute delayed shutdown simultaneously. The error voltage fed back from the secondary side output voltage and the voltage sensed by the MOSFET sense terminal are compared to drive the gate and modulate the pulse width to control output voltage. For normal operation, the feedback voltage is between 0~3V and, when it is 3V, the MOSFET drain current is maximum. During normal operation, the feedback capacitor is charged through the internally designed current sources, 1mA and 5uA, and is then discharged to the secondary side photo-coupler to control the output voltage.

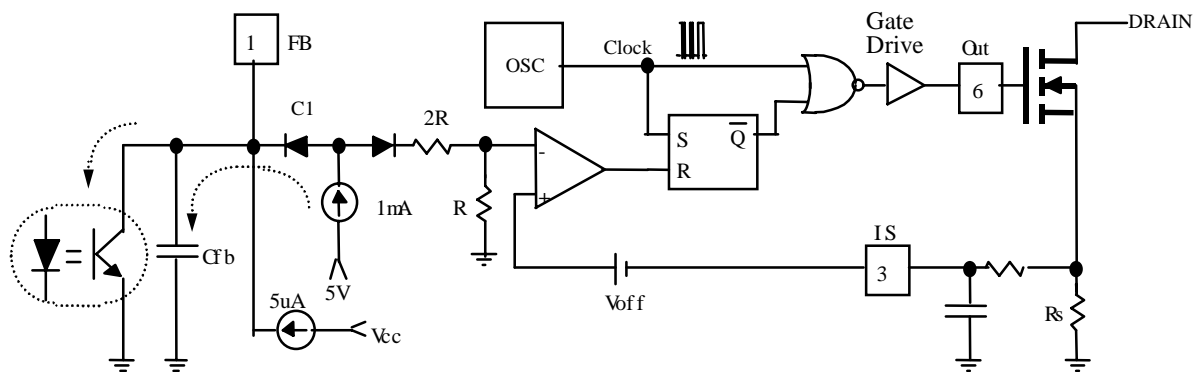

Figure 6. Feedback & PWM Circuit

Delayed Shutdown

When the feedback loop is operating normally, the feedback voltage remains between 0~3V. If the load at the output terminal overloads or an error develops in the feedback loop, the delayed shutdown circuit starts. If the abnormal state, which feedback capacitor discharge is stopped by the photo-coupler, the delayed shutdown circuit converts to the charging mode. When the feedback voltage is less than 3V, the feedback capacitor is charged through 1mA and 5uA; when the feedback voltage becomes greater than 3V, the capacitor is charged through 5uA because diode D1 turns off. When the feedback voltage is less than 3V, the charge slope becomes an exponential function due to the IC internal resistance, and, greater than 3V, the charge slope becomes linear. When the feedback voltage reaches almost 6V, the delayed shutdown with the latch circuit shuts down the IC. The shutdown circuit is configured for auto-restart, so it automatically restarts when Vcc reaches the under voltage 9V.

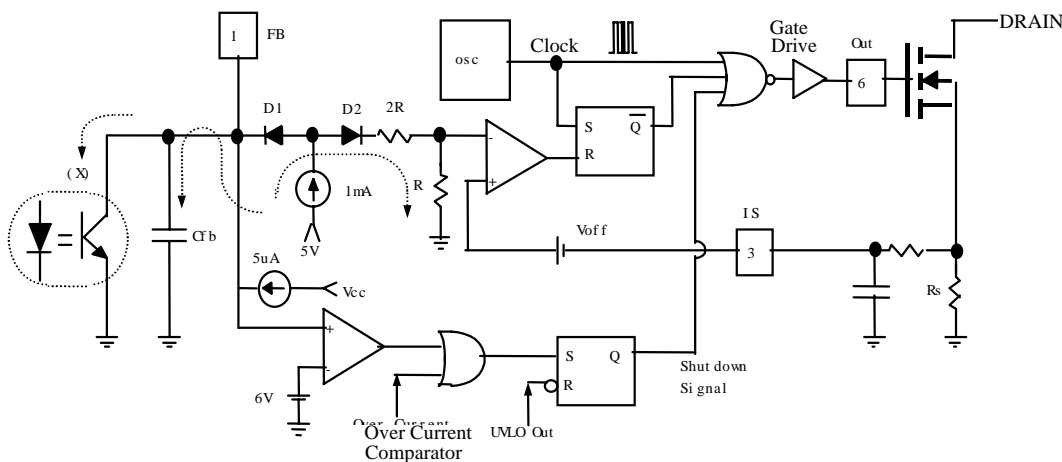

Figure 7-A . Delayed Shutdown & Feedback Circuit

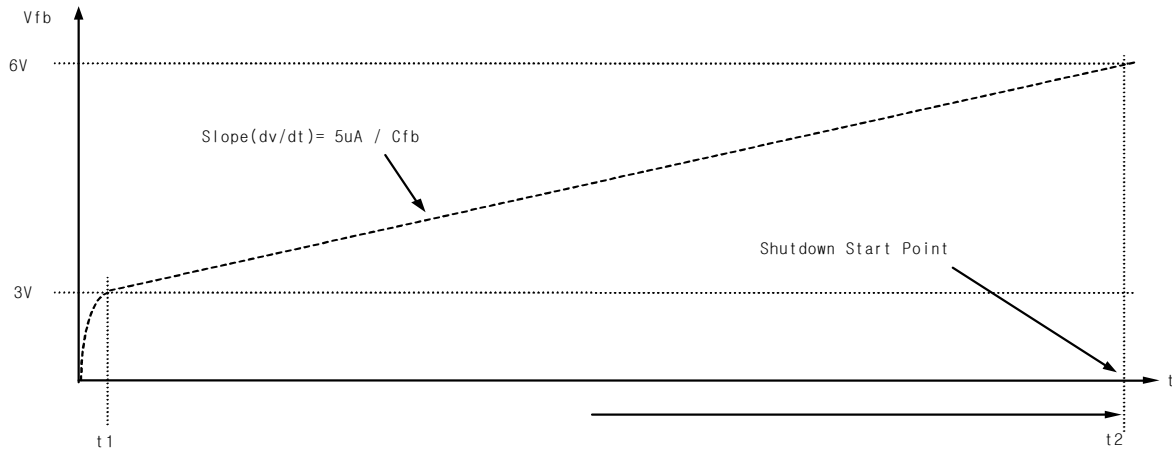

Figure 7-B . Delayed Shutdown & Feedback Waveform

Gate Driver

Gate Drive circuit has the Totem-Pole Output configuration. The output has 1A Peak Current and 200mA Average Current drive ability.

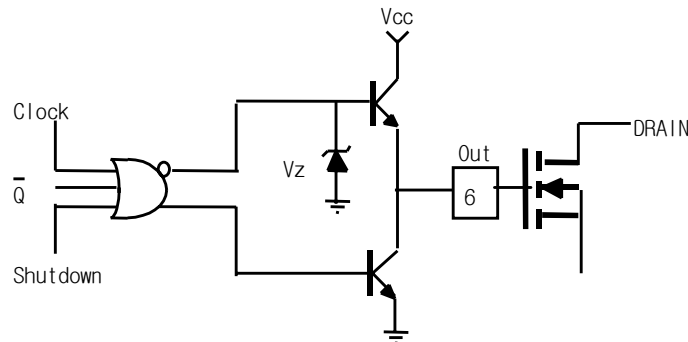

Figure 8. Gate Drive Circuit

ON/OFF Control

The FAN7554 does not have a pin specifically for ON/Off control but is able to use the feedback pin without extra components for on-off control. When the circuit control unit sends the off signal, the current is forced to flow to the photo-coupler diode, completely saturating the photo-coupler transistor. As a result, the feedback voltage discharges through the transistor. When the feedback voltage becomes less than 0.3V, the soft start pin voltage can be dropped depending on the internal 1KΩ resistor and external capacitor Cs's time constant; when the S/S pin voltage becomes less than 1.5V, turns off the Vref block and cutting off all the circuit in FAN7554, with the exceptions of the ULVO circuit and On/Off control circuit. It drives the output drive in low through the Good Logic block and discharges the Cs potential to the GND. Such double OFF control prevents abnormal operation from a transient state or noise environment and provides for a more stable operation. Because a 5uA current source is connected to Cfb even in off state, Cfb is charged if an ON signal is received. When the feedback voltage exceeds 0.3V, it operates normally by turning on the Vref block. The operating current is about 200uA (Typ.) in off state, so the circuit consumes low power.

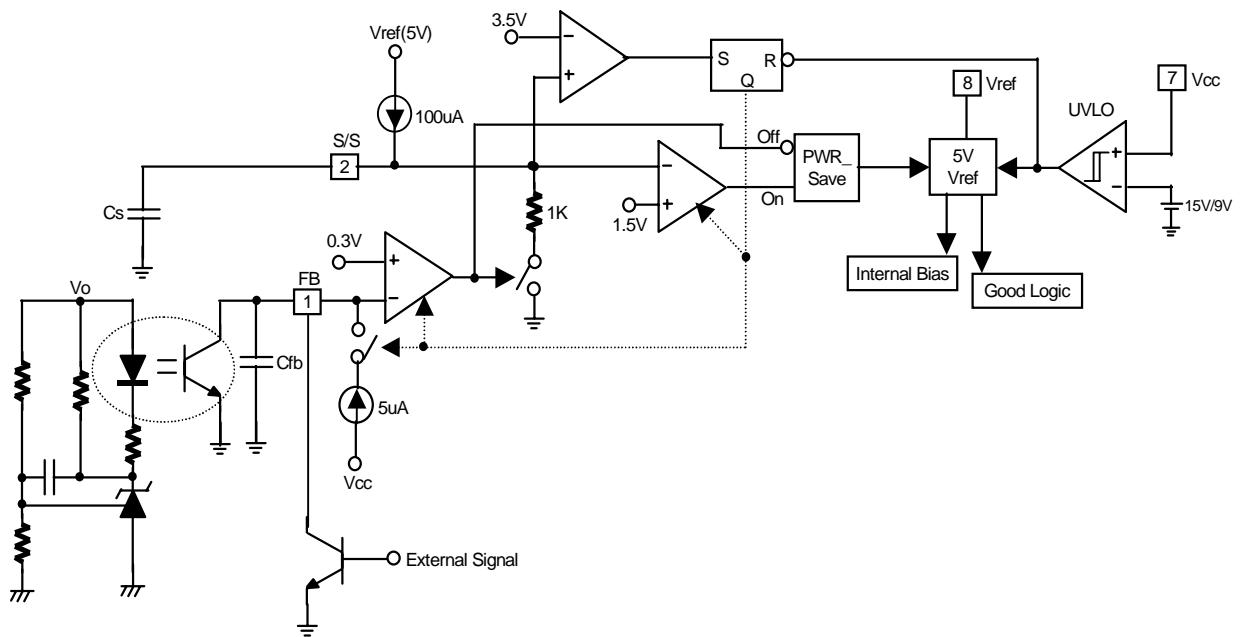

Figure 9. ON/OFF Control Circuit

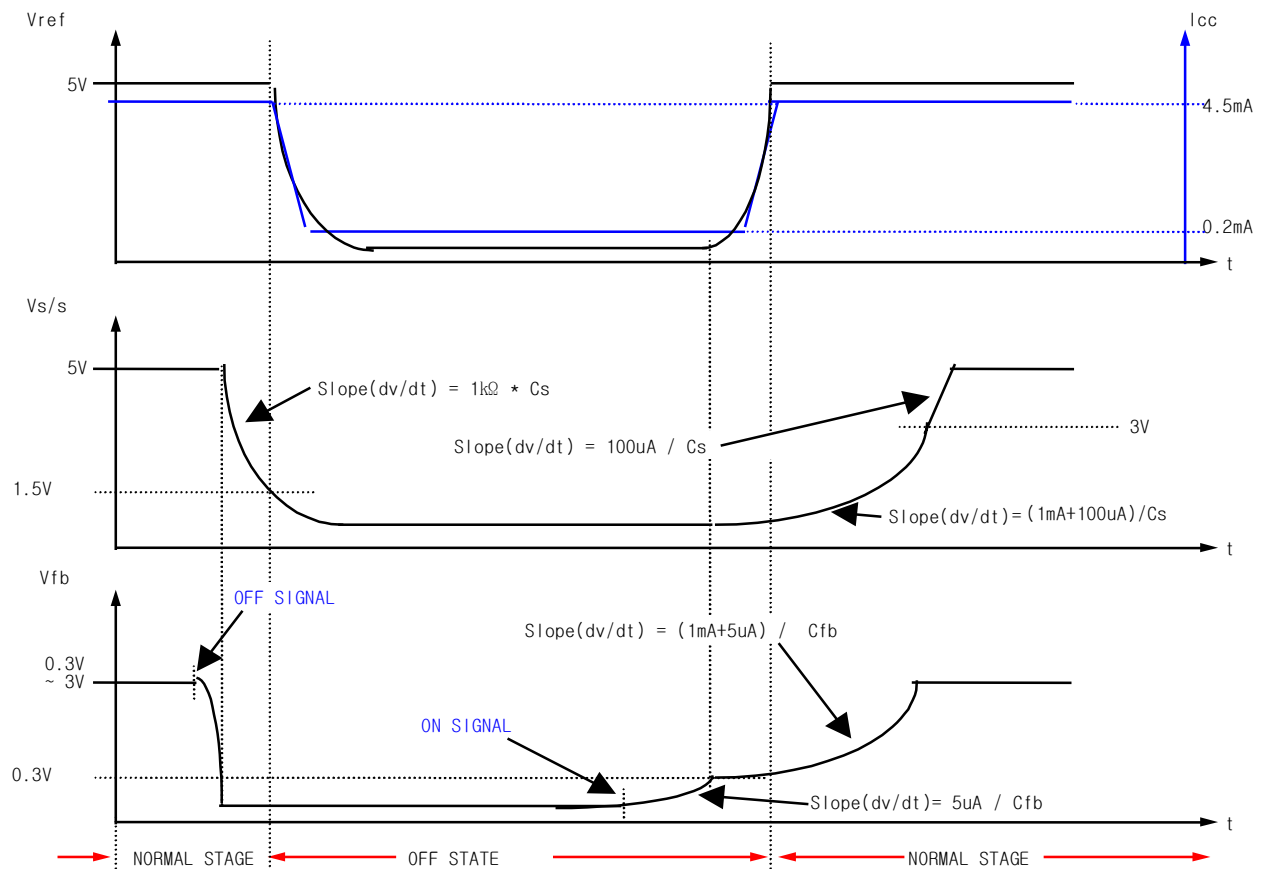

Figure 10. ON-OFF Control Circuit Waveform

Protection Circuits

FAN7554 has many built-in protection circuits that do not need additional components, providing reliability without cost increase. These protection circuits have the Auto-restart configuration. In this configuration, the protection circuit resets when Vcc is below UVLO stop threshold (9V) and restarts when Vcc is above UVLO start threshold (15V)

- Over Voltage Protection

Even if the feedback circuit appear to be open due to an error in the secondary side feedback or no soldering , the switching on the primary side still continues until the protection circuit starts; this causes the secondary side voltage to become much greater than the rated voltage.

The over voltage protection circuit of FAN7554 senses Vcc inside the IC. If Vcc becomes greater than 34V, the protection circuit starts to operate. Because Vcc is in proportion to the output line voltage of the flyback converter, Vcc during normal operation should be appropriately maintained at less than 34V.

- Over Load Protection

An overload is different from a short load. An overload occurs when a load becomes greater than the preset load during normal operation. for example, the IC stops itself if the SMPS outputs 110W when it exceeds the preset maximum power of 100W. If this protection circuit initiates, then this could perform an undesired execution even during a transient state. Therefore, as a measurement against such a happening, the protection circuit in FAN7554 is forced to wait a specified time before operating to determine whether the recognized overload is a transient or a overload state.

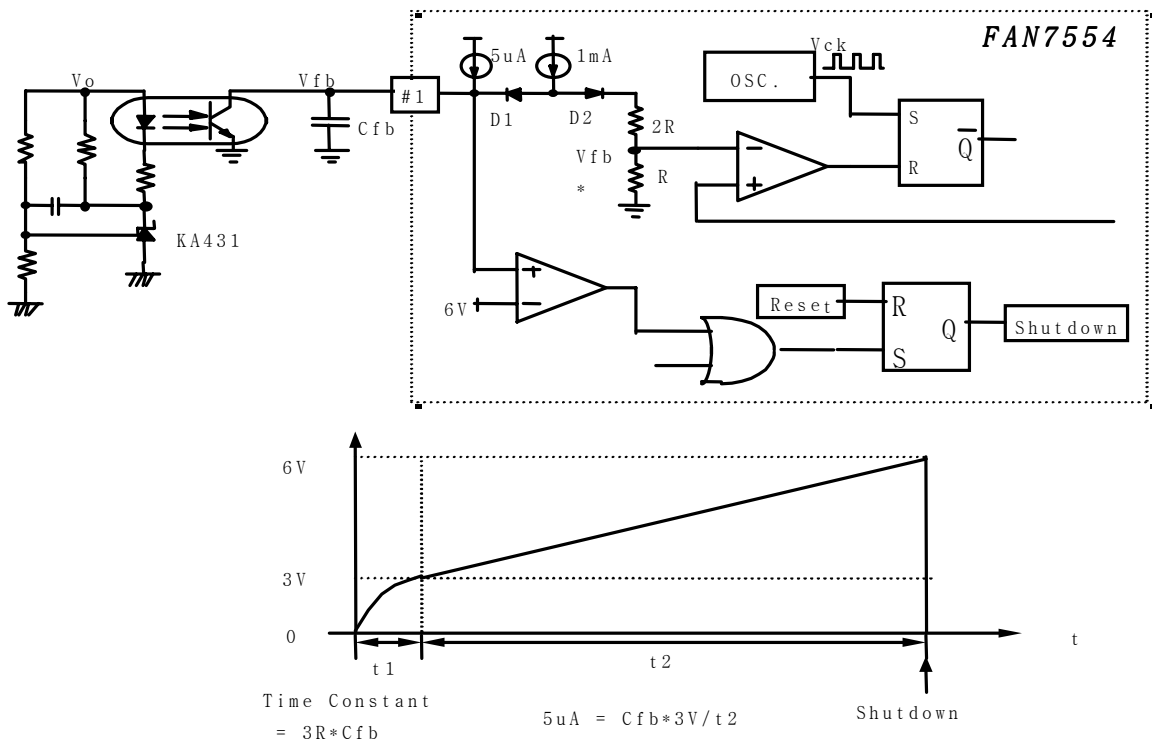

Application Circuit

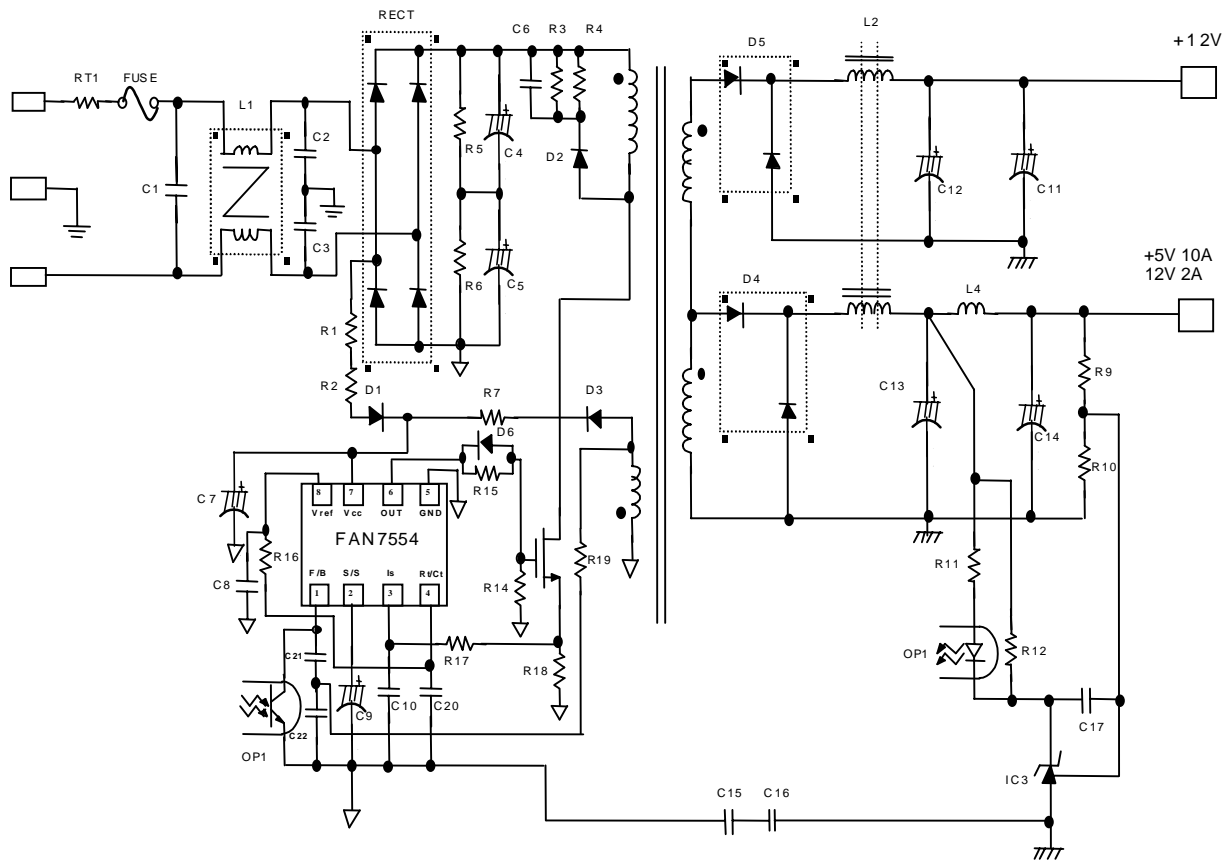

Figure 12. 100W Forward converter circuit with FAN7554

Part List

Part	Value	Part	Value	Part	Value
RT1	NTC:10D-11	R19	2.2k	C20	332 ⁽²⁾
R1	33k (1/2W)	C1	0.47uF(275V) ⁽¹⁾	C21	272 ⁽²⁾
R2	33k (1/2W)	C2	472 (1kV) ⁽²⁾	C22	333 ⁽²⁾
R3	56k (2W)	C3	472 (1kV) ⁽²⁾	D1	1N4004
R4	56k (2W)	C4	470uF(200V) ⁽³⁾	D2	FR157
R5	220k (1W)	C5	470uF(200V) ⁽³⁾	D3	UF4007
R6	220k (1W)	C6	223 (630V) ⁽³⁾	D4	S30SC4M (25A)
R7	6.8Ω	C7	33uF(35V) ⁽⁴⁾	D5	SBL1040CT (10A)
R9	50k (1%)	C8	104 ⁽²⁾	D6	1N4148
R10	50k (1%)	C9	1uF(10V) ⁽³⁾	L1	Line Filter
R11	1k	C10	101 ⁽²⁾	L2	9.2Ω
R12	820Ω	C11	1000uF (16V) ⁽³⁾	L3	1ron Power 27Φ
R13	-	C12	1000uF (16V) ⁽³⁾	L4	10uH
R14	47k	C13	3300uF (10V) ⁽³⁾	OP1	PC817
R15	20Ω	C14	3300uF (10V) ⁽³⁾	FUSE	5A/250VAC
R16	7k	C15	-	RECT	PBS406GU
R17	1k	C16	-	Q1	SSH8N80
R18	0.6Ω (1W)	C17	105 ⁽²⁾	-	-

*Note

*(1) Box Capacitor (2) Ceramic Capacitor (3) Electorlytic Capacitor (4) Film Capacitor

Mechanical Dimensions

Package

Dimensions in millimeters

8-SOP

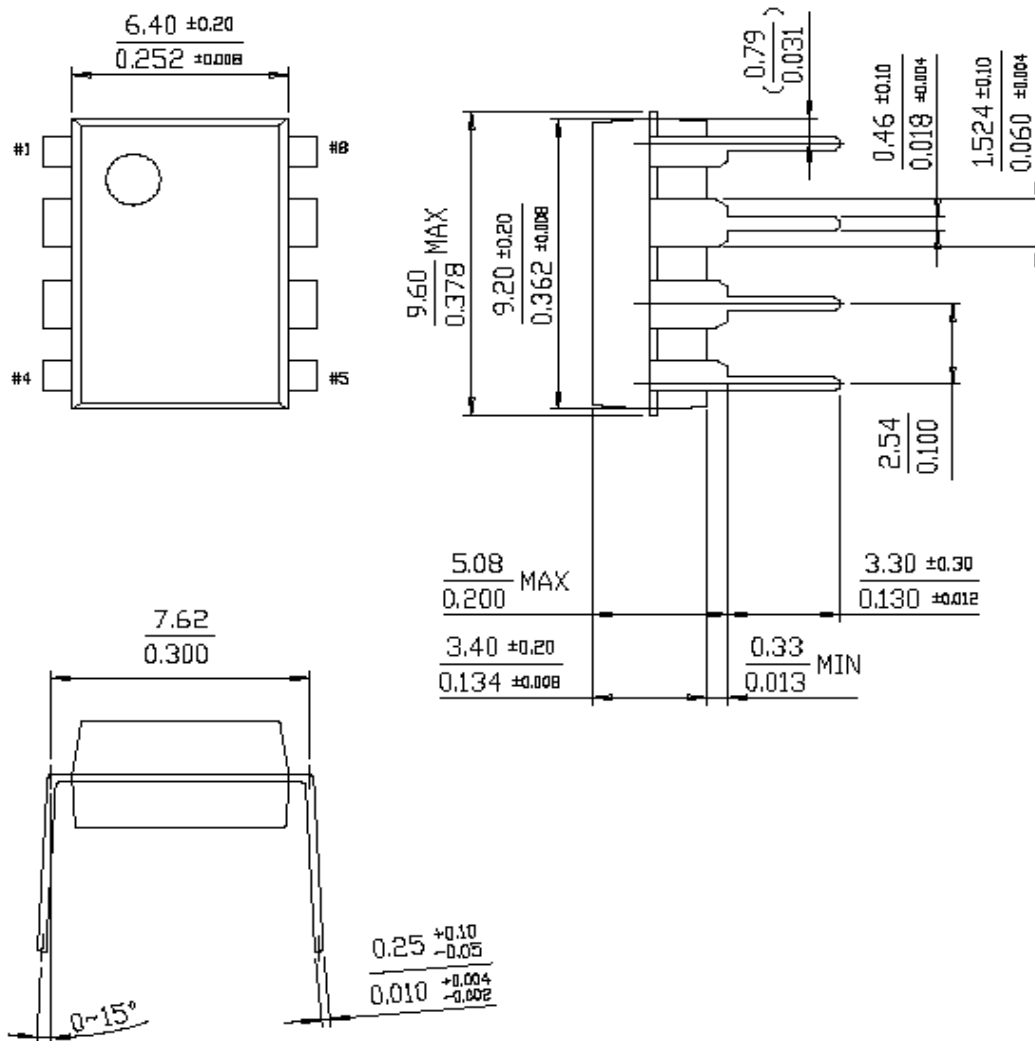

Mechanical Dimensions (Continued)

Package

Dimensions in millimeters

8-DIP

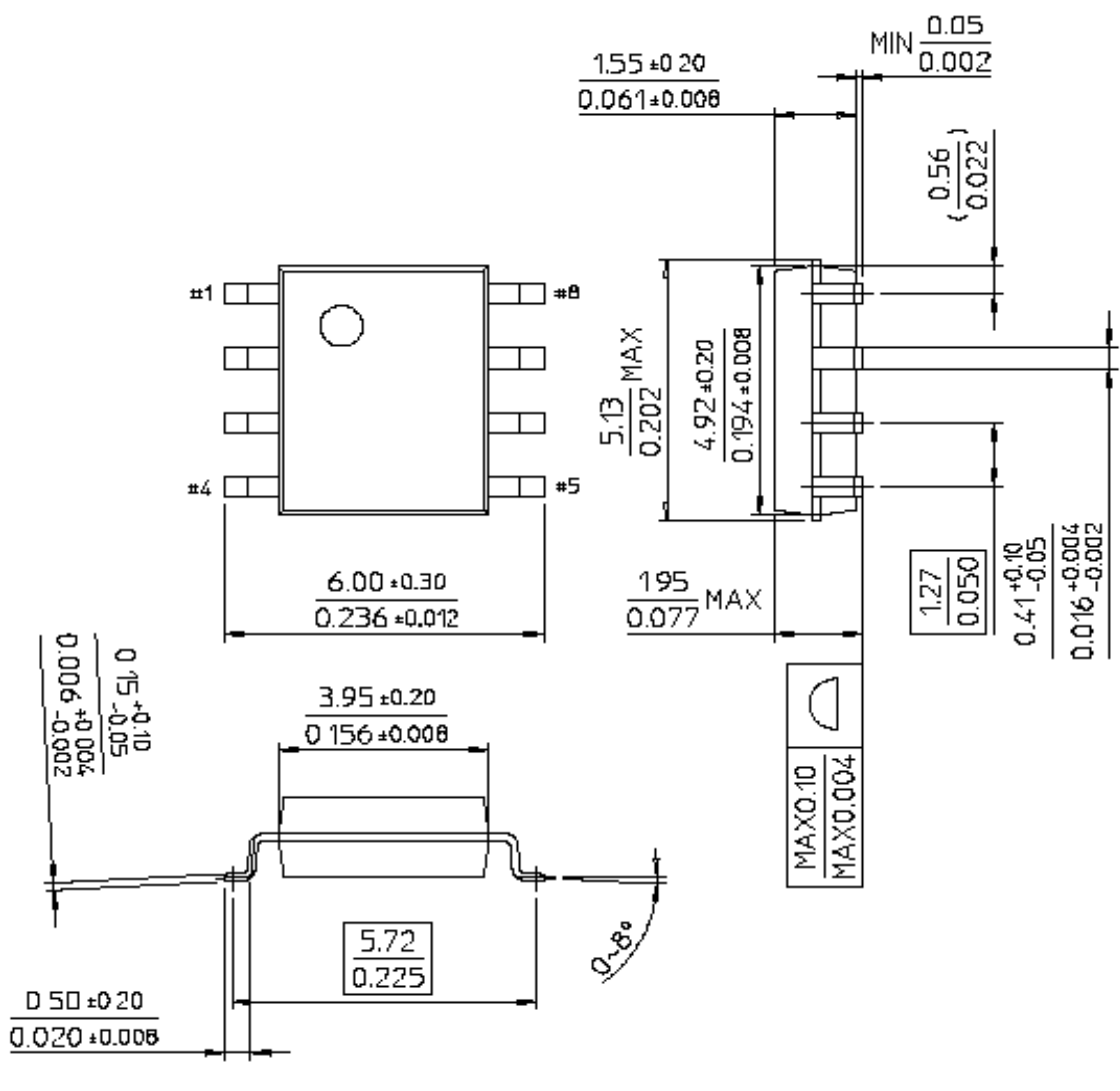

Ordering Information

Product Number	Package	Operationg Temperature
FAN7554	8-DIP	-25°C ~ 85°C
FAN7554D	8-SOP	

DISCLAIMER

FAIRCHILD SEMICONDUCTOR RESERVES THE RIGHT TO MAKE CHANGES WITHOUT FURTHER NOTICE TO ANY PRODUCTS HEREIN TO IMPROVE RELIABILITY, FUNCTION OR DESIGN. FAIRCHILD DOES NOT ASSUME ANY LIABILITY ARISING OUT OF THE APPLICATION OR USE OF ANY PRODUCT OR CIRCUIT DESCRIBED HEREIN; NEITHER DOES IT CONVEY ANY LICENSE UNDER ITS PATENT RIGHTS, NOR THE RIGHTS OF OTHERS.

LIFE SUPPORT POLICY

FAIRCHILD'S PRODUCTS ARE NOT AUTHORIZED FOR USE AS CRITICAL COMPONENTS IN LIFE SUPPORT DEVICES OR SYSTEMS WITHOUT THE EXPRESS WRITTEN APPROVAL OF THE PRESIDENT OF FAIRCHILD SEMICONDUCTOR INTERNATIONAL. As used herein:

1. Life support devices or systems are devices or systems which, (a) are intended for surgical implant into the body, or (b) support or sustain life, and (c) whose failure to perform when properly used in accordance with instructions for use provided in the labeling, can be reasonably expected to result in a significant injury of the user.
2. A critical component in any component of a life support device or system whose failure to perform can be reasonably expected to cause the failure of the life support device or system, or to affect its safety or effectiveness.

This datasheet has been download from:

www.datasheetcatalog.com

Datasheets for electronics components.