

BEKKO
COLOUR TELEVISIONS

L6B PDP TV

SERVICE MANUAL

<u>CONTENTS</u>	<u>PAGES</u>
Safety Instuctions	2-5
Technical Specification	6-7
User Instruction	8-29
Back Appearance of TV	30
Interconnection Diagram	31
Block Diagram	32
Block Diagram of Power Supply	33
Service Mode	34-35
Data Sheet of important IC's and parts	36-46
Part List	47-49
Frequency list of channel	50-52
ATTACHMENT 1:	Panel Service Manual LG-PDP42V6
ATTACHMENT 2:	Panel Service Manual Samsung 42" S3
ATTACHMENT 3:	Circuit Diagrams

SAFETY PRECAUTIONS

GENERAL GUIDELINES

1. It is advised to insert an isolation transformer in the AC supply before servicing a hot chassis.
2. Always use the manufacturer's replacement safety components. The critical safety components marked with ∇ on the schematics diagrams should not be by other substitutes. Other substitute may create the electrical shock, fire or other hazards. Take attention to replace the spacers with the originals. Furthermore where a short circuit has occurred, replace those components that indicate evidence of overheating.
3. After servicing, see that all the protective devices such as insulation barriers, insulation papers, shields and isolation R-C combinations are correctly installed.
4. When the receiver is not being used for a long time of period of time, unplug the power cord of the Adaptor from the AC outlet.

PDP Module is very sensitive both electrically and physically. Users, therefore, are requested to follow the "Guidance of handling color PDP Module" on the followings.

1 - Be careful not to make scratch on the polarizer.

Surface of polarizer is soft and can be physically damaged easily. Please do not touch, push or rub polarizer surface with materials over HB hardness.

2 - Keep clean the surface.

Please wear rubber glove when touch the surface of PDP screen. Please use soft and anti-static material as cleaner.

3 - Keep out of water. Water on/in the PDP may cause electrical short or corrosion. Please wipe out dry or water carefully.

4 - Prevent swift Temperature & Humidity change. Instantaneous temperature and/or humidity change can make dew or ice which cause nonconformance such as malfunction.

5 - High temperature & high humidity reduce the life-time.

PDP is not proper to be used at high temperature and high humidity. Please keep specified temperature and humidity condition.

6 - Keep out of Corrosive Gas. Corrosive gas effect the polarizer and the circuit chemically and cause defects accordingly.

7 - Electrostatic discharge can make Damage

There are electro-static sensitive components in PDP Module. Please earth human body when handle the PDP. In addition, please do not touch the interface connector pin with bare.

8 - Do not operate for a long time under the same pattern

Operating PDP for a long time under the same pattern can cause image persistence and can damage it. Please follow following guidance.

1. Turn the power off when do not use.
2. Change the pattern periodically.

LEAKAGE CURRENT COLD CHECK

1. Unplug the AC cord and connect a jumper between the two prongs of the plug.
2. Turn the receiver's power switch.
3. Measure the resistance value with an ohmmeter, between the jumpered AC plug and each exposed metallic cabinet part on the receiver. When the exposed metallic part a return path to the chassis the reading should be between 4Mohm and the 20Mohm. When the exposed metal does not have a return path to the chassis, the reading must be infinite.

LEAKAGE CURRENT HOT CHECK

1. Plug the AC cord directly in to the AC outlet. Do not use an isolation transformer for this check.
2. Connect a 2Kohm 10W resistor in series with an exposed metallic part on the receiver and an earth, such as a water pipe.
3. Use an AC voltmeter with high impedance to measure the potential across the resistor.
4. Check each exposed metallic part and check the voltage at the each point.
5. Reverse the AC plug at the outlet and repeat each of the above measurements.
6. The potential at the any point should not exceed 1.4 Vrms. In case a measurement is outside the limits specified, there is the possibility of a shock hazard, and the receiver should be repaired and rechecked before it is returned to the customer.

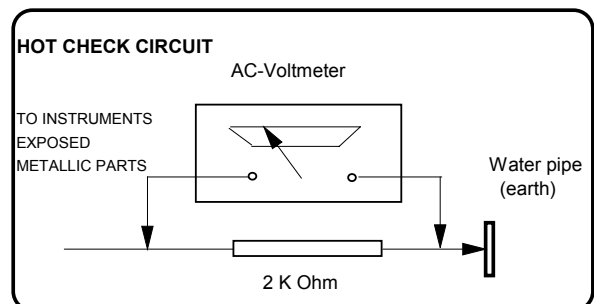

Important information

Read and heed the notes on safety so that no hazard to your health arises during contractual use. Errors during installation and connection can damage the device or subsequently related devices. Always keep the operating instructions within reach. Heed the warnings on the device and in the operating instructions.

• General reference

Before you connect the plasma display, please carefully read through the general notes on safety and the operating instructions. Only in this manner can you utilise all functions safely and reliably.

As far as possible, keep the operating instructions together with the device so that you can use it to look up information.

Heed the warnings on the device and in the operating instructions.

Never allow children to utilise electrical devices without supervision.

• Operation

The plasma TV acquired by you, meets the highest quality codes and standards to be found in this business segment. A plasma display consists of a multitude of so called pixels. One pixel consists of 3 elements (red, green and blue). Even using the highest quality control practices during the manufacture of the displays, it can not be 100 % excluded that some pixels or pixel elements will be defective. These defects may appear as permanent illuminated pixels, non illuminating pixels or unstable pixels (flickering) respectively. We therefore ask for your understanding when we declare that these defects are not covered under the warranty liability. This is valid insofar that the sum of all defective pixels or pixel elements does not exceed 0,01 % of the total amount.

The brightness and contrast of plasma displays decreases with time.

Plasma displays are phosphor based and under certain operating conditions, so-called "Burn-In" effect may occur. This is in fact a degradation of the phosphor and is a natural process in plasma technology.

Such operating conditions are:

- static images being displayed for long periods
- continues display of the same background
- use of a non full screen format (e.g. 4:3) for a long periods.

Once Burn-In has occurred it is normally irreversible.

To avoid or to reduce the Burn-In effect, please follow the listed recommendations:

- Please use moving images or continuous moving static images in full screen format (slide show) during the first 100 hours of operation
- Please use your plasma TV in a full screen format (16:9)
- In case the plasma display is used as a PC monitor, please use moving images
- Always switch the screen off, if it is not in use

- Decrease contrast and brightness as much as possible
- If possible display images with maximum colour depth and scale

Certain conditions may cause a humming noise in the displays electronics. This is usually caused by the mains power supply having different ground wires. One remedy for solving this problem is to insert a filter between antenna cable and antenna input. These filters are available at all specialised trade outlets.

If the plasma display is connected to an external antenna, it has to be grounded to protect against electrical hazards and static discharges. The grounding must conform and be in accordance with the actual regulations in force.

• Environmental conditions

Never operate the plasma display under environmental conditions which differ from those of the technical data. Divergent conditions can lead to endangerment, fire or breakdown of the device.

Protect the plasma display against moisture. This pertains to permanent high humidity, the proximity to water, water drops and water splashes as well as rain. Do not place any water-filled containers (e.g. vases) on the device.

Protect the device against heat. Avoid the proximity, to fire, heating devices, ovens or permanent exposure to direct sunlight.

Protect the display against heat accumulation. Do not cover the ventilation slots. Maintain a distance of at least 10 cm above and below the ventilation from sides 4 cm from rear 4 cm slots as well as laterally to furniture and to the ceiling. Do not furnish the device with curtains.

The display is designed for mounting in landscape format on walls or installations.

• Mains connection

The mains input and the mains switch are located on the rear side. The mains input is located on the upper right and the mains switch is placed in the upper middle. For safe disconnection of the display from the mains voltage, the mains switch is to be turned off and the mains cable is to be removed from the mains input module.

Connect the plasma display only to a socket with earthing contacts installed according to regulations, and whose main voltage conforms with the device's technical data. See to it that the mains plug and the socket are accessible at all times. Install the mains cable in such a fashion that nobody can get caught in it. Use only the supplied mains cable. Protect it against damages, and do not make any alterations to it. Never use a damaged mains cable.

- **Signal inputs**

Always turn the plasma display and the signal source off before you establish a connection between both devices.

- **Disturbances**

In the event of damages to the mains cable or the device, immediately pull the mains plug from the socket.

Under no circumstances should you attempt to open and/or to repair the device yourself. Instead, contact our Service Hotline or another suitable professional workshop.

- **Batteries**

Batteries can be life-threatening when swallowed. That's why you should safeguard batteries from the reach of small children. Immediate medical assistance should be utilised if a battery has been swallowed.

Always take the exhausted batteries out of the remote control immediately, since these leak and can cause damage as a result.

The enclosed batteries may not be charged or reactivated by other means, not taken apart, thrown in fire or short-circuited.

TO FULLY DISCONNECT THE TV, SWITCH OFF THE MAINS SOCKET AND REMOVE THE POWER PLUG.

Exhausted batteries do not belong in household waste. The batteries must be disposed of at the collection points provided for this purpose.

- **Cleaning and maintenance**

Before cleaning, turn the device off, and pull the mains plug from the socket. Wait a few minutes so that the capacitors in the device can be completely discharged.

Use only a slightly dampened, soft cloth for cleaning. You should avoid chemical solvents and cleaning agents, because these can damage the surfaces.

- The plasma display generates high voltage internally for the gas discharge. Turn the device off and pull the mains plug from the socket during installation, maintenance and repairs. Wait a few minutes so that the capacitors in the device can be completely discharged.
- In case foreign elements such as water, liquids, metal parts, etc. get into the plasma display, pull the mains plug out immediately. Never attempt to touch anything inside the device with any kind of objects. The danger of an electric shock or accident exists.
- Pull out the mains plug immediately if smoke, unpleasant odour or unusual noises are emitted from the device. Also proceed in the same manner if the display is no longer able to present an image after being turned on or during operation. Never attempt to continue operating the display in this condition.

- In the event of lengthy absence or during thunderstorms, pull the mains plug from the socket, and pull the house antenna socket from the antenna jack.
- Never plug-in or pull-out the mains plug with wet hands. Never operate the mains switch with wet hands.
- Utilise only the supplied mains cable. Protect it against damages, and do not make any alterations to it. Never use a damaged mains cable.
- The plasma display has a glass surface. Should the device be subjected to excessive loading (e.g. through shock, vibration, bending and heat shock), the glass surface can break. Do not subject the glass surface to any pressure or shock. Should the glass be broken, immediately pull the mains plug and do not touch the broken glass with bare hands.
- When the plasma display has been switched to the stand-by mode it is still connected to the mains. You must switch the mains switch into the 0 position or pull the mains plug from the socket for complete disconnection.
- For ergonomic reasons it is recommended to avoid using red and blue fonts or symbols on dark backgrounds. Such a display causes poor readability due to the lower contrast, and prematurely fatigues the eyes. Therefore, please use high-contrast displays as much as possible, e.g. black font on a white background.
- During the connection of external loudspeakers, pay attention to the loudspeaker output technical data. In the event of insufficient dimensioning of the loudspeaker, the loudspeaker and/ or the built-in amplifier can be damaged.
- Packaging and packing resources which are no longer needed are able to be recycled, and should always be turned in for recycling.
- Place the carton upright with the underside on firm ground. You will recognise the top side by the direction of the arrowheads on the longitudinal side
- The plasma display may only be mounted on vertical (plumb) walls by means of the wall mounting unit. Before beginning the mounting, make sure that the display is turned off and the mains cable and signal cable are unplugged. The background has to be firm and structurally able to carry a load. Appropriate materials are to be utilised for varying wall superstructures, such as wooden walls or hollow-space walls. If there's any doubt, contact your responsible sales or service department.

Important notes on safety!

Your safety and the safety of others is important. Please, therefore, ensure you read the Safety instructions **before** you operate this television.

Safety instructions

! Read all the safety instructions before first use of your TV.

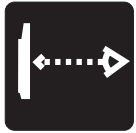

- Position the television so that direct light does not fall on the screen. Excessive light will cause a washed out effect.



- Position the power supply lead and other leads so that they are not likely to be walked on or pinched by things placed on or against them.



- Do not place objects filled with liquid such as vase or flower pot near the television.
- Do not expose the TV to dripping or splashing of liquids.
- Do not place naked flame sources such as lighted candles on the TV set.



- Make sure that no naked flame sources, such as lighted candles, are placed on top of the appliance.
- Do not place the television near heat sources such as radiators, ovens, stoves, etc.



- Do not push, hit or screw the screen of your product.



- The heat built up in the set escapes through ventilation holes, so do not cover the set by drapes, clothes etc. that may block air circulation. Do not place the television on carpet or soft furnishings.
- Never let children push anything into the holes or slots on the case.



- Clean the TV Screen using a slightly damp cloth or chamois leather. Never use abrasive cleaning agents like liquid or aerosol cleaners.
- Remove the mains plug from the socket outlet while cleaning.



- Never apply pressure on the screen when cleaning.
- Never put your screen on hard objects. Your PDP screen may be damaged.

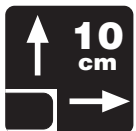

- If you wish to place the television on a shelf or in a wall unit always ensure there is a minimum air gap of 10 cm around the top, sides and rear of the television, to assist ventilation.



- Your TV set is designed to operate with mains voltages 230V AC; 50Hz. Do not connect your TV set to power sources other than the mains supply.
- If you don't use the television for a long period, please remove the mains plug from wall socket outlet.
- Your TV set is designed as a CLASS I apparatus, the TV set has to be connected to a mains socket outlet with a protective earthing connection.
- To fully disconnect the TV, the mains plug is used as a disconnecting device and therefore shall be readily operable.

PC FORMATS

DOS Modes 640 x 400 and 720 x 400
 VGA (640 x 480) @ 50Hz - 90Hz repetition rate
 SVGA (800 x 600) @ 50Hz - 90Hz repetition rate
 WVGA (848 x 600) @ 50Hz - 90Hz repetition rate
 XGA (1024 x 768) @ 50Hz - 90Hz repetition rate

IMAGE FORMATS

4:3, 16:9, auto, zoom, letterbox, subtitle

INPUTS/VIDEO

Mini DIN.....Y/C / Hi 8 (PAL, SECAM, NTSC)
 Cinch.....CVBS Video In (PAL, SECAM, NTSC)
 SCART 1CVBS, RGB (PAL, SECAM, NTSC)
 CVBS output
 SCART 2CVBS, RGB (PAL, SECAM, NTSC)
 CVBS output

RF Tuner.....VHF/UHF/HYPERBAND for terrestrial
 antennas or cable networks (47MHz to 861 MHz)
 (PAL, SECAM)

PC

DVI (D).....VGA/SVGA/WVGA/XGA
 Digital (DVI)

AUDIO INPUTS

Y/C (S-Video) - CVBS
 SCART 1
 SCART 2
 PC

OUTPUTS

Cinch.....L/R Audio Output
 loudspeaker.....2 x 7W sine @ 4 Ω
 Cinch.....CVBS Output

CONTROL

On-Screen Display Menu.....24 languages
 IR remote control

VIDEOTEXT

TOP FLOF.....800 pages of memory
 control with special keys on the remote control

OPERATING VOLTAGE RANGE

170V - 240V AC alternating voltage
 50Hz

POWER CONSUMPTION

275 W

Special Features

- 42" PDP VGA Panel
- 852x480 pixels
- 16,722,216 color (8 byte)
- Available for Cable Channels (A decoder may be required)
- 3000:1 contrast ratio
- 2x7 W Stereo sound (With detachable speakers)
- 800-Page Teletext Feature
- PIP (Picture in Picture) Feature
- Wide angle perspective
- SCART socket, AV Socket and external sound system connection
- S-VHS and Cinch inputs for S-Video connection
- DVI connection
- PC connection
- AVL – Automatic Volume Limiting
- ATS – Automatic Tuning System
- Programmed power off
- Graphic equalizer
- Color Transfer sharpness feature (CTI)
- Black-White Transfer sharpness feature (LTI) and picture sharpness
- Compound Filter (Digital Comb Filter) Feature for clear images
- On screen viewing of all control commands, program numbers and additional features
- Manual Fine Tuning
- 100 Program memory
- Infrared Remote Control
- Child lock (this feature works like a Panel Lock)
- Ability to watch NTSC broadcasts through SCART input
- Easy handling through an advanced menu system. Ability to choose from 24 languages.

Connection of Mains Cable

Always utilise the enclosed mains cable in order to guarantee optimal image quality. First of all, insert the main cable into the input panel, and only thereafter into the socket.

- Never utilise a damaged mains cable!
- Use only sockets with a protective earthing conductor system to ensure safe operation.

A line filter and switches for stabilisation of the supply voltages ensure safe operation within normal mains voltage variations. In case the mains voltage lies beyond the stated limits, please contact your responsible sales office. In the event the mains cable cannot be utilised on account of differing standards in your country, please see to it that you utilise a mains cable commensurate with the country-specific standards which are listed in the following:

- | | |
|-----------------|---------|
| • USA | UL |
| • Germany | VDE |
| • Canada | CSA |
| • Switzerland | SEV |
| • Great Britain | BASE/BS |
| • Japan | MITI |

This list is not complete. For reasons of safety it may be necessary to select a different safety standard.

At any rate, the mains cable has to consist of three wire conductors of at least 10A/0.75 mm² in order to avoid an accident as a result of electric shock. One of the three wires is implemented on both ends of the cable as an earthing contact connection.

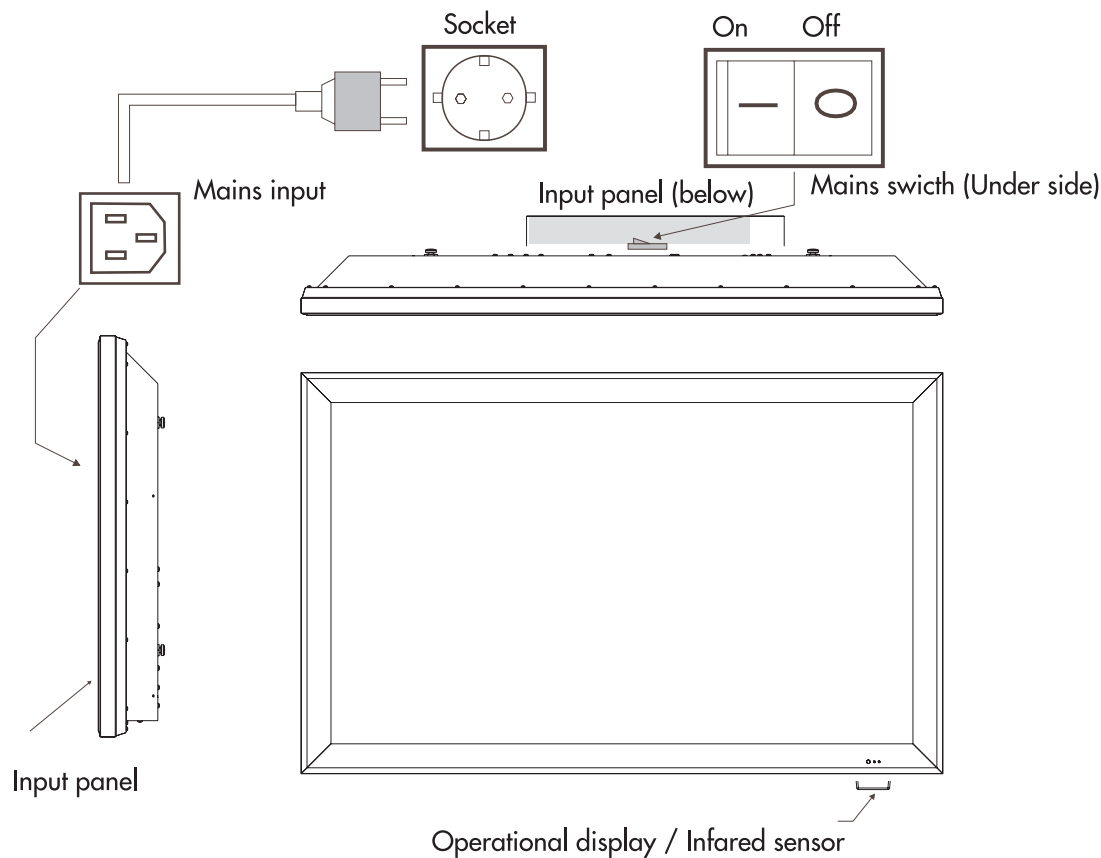

Turning On the Plasma Display

You can only control your plasma display with the remote control when the device is in stand-by mode. Switch the mains switch in the input panel into Position I. The operational display on the front side of the display screen lights up red.



- Press a numeric button or the **Program Up / Program Down** button on the remote handset or **PR+ / PR-** or **MENU** button on the front panel of the TV to switch the TV on. The standby indicator turns into green. The picture will appear after a few seconds.

Press the **Standby** button to switch the TV to standby. The standby indicator turns into red.

- The plasma display is always connected to the power supply network in stand-by mode. You must switch the mains switch into position 0 and pull the mains plug from the socket for complete disconnection.
- Display has a mains adapter, and can be operated with a supply voltage of 230V AC and 50HZ.

Note 1: Your TV will go to stand-by mode in five minutes if there is no broadcast signal.

Note 2: Your TV is equipped to operate with front panel buttons, "MENU", "SOURCE", "▼ PROG ▲", "◀ VOL ▶" in case your R/C is broken or the batteries are exhausted.

The batteries

Remove the back cover to reveal the battery compartment and make sure you insert the batteries the right way round.

Suitable battery types for this remote are UM-4, IEC R03 or AAA 1.5V.

Do not combine a used, old battery with a new one or mix battery types.

The performance of the remote control will deteriorate beyond a distance of 8 metres or outside an angle of 30 degrees from the centre of the TV.

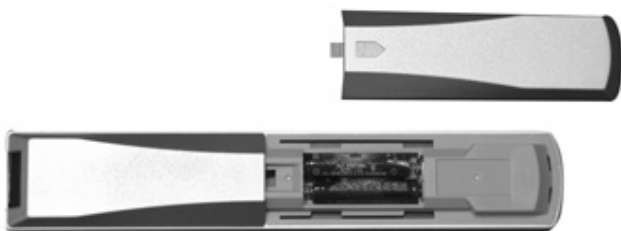

Operating Modes



Operating mode at the beginning of utilisation

Due to the functionality of the Plasma-TV please pay attention, that particularly during the first 100 to 150 operation hours the display has to operate with a full screen format adjustment (see submenu Display, Picture Format). This prevents the formation of brightness differences in the display areas. As an alternative to the picture format 4:3 the adjustment Video NLS should be selected.

Further on, in order to prevent the formation of permanent shadows in the displayed image, please avoid to show fixed-images of any kind (PC mode, teletext pages, Photo CD image etc.) during the first operation hours. If the Plasma-TV will be used as a PC monitor, the utilisation of a screensaver is recommended.

PC mode

For optimal image reproduction, we recommend the 848 x 480, 640 x 480 or 720 x 400 pixel resolutions. The 848 x 480 pixel resolution corresponds to the display matrix, and offers the best image reproduction. You can obtain the driver for this resolution on the Internet pages of most of the well-know manufacturers of graphics cards.

In contrast to applications with CRT monitors, with flat displays it is not necessary to select a high image refresh for a flicker-free presentation. A refresh of 60Hz is recommended.

Video recorder mode

The utilisation of Y/C (S-Video) inputs is recommended for enhancement of image quality - if your recorder offers playback in Y/C (S-Video) format.

DVD player mode

The application of the RGB operating mode, which can be connected to the SCART 1 input, is recommended for optimal utilisation. In case your player does not offer this operating mode, please use the Y/C (S Video) signal mode.

Image sticking

The manufacturer would like to point out to you that during lengthy viewing of freeze pictures (e.g. PC playback), the image is still slightly visible in the full mask for a few minutes during the subsequent playback of a different source. This is known as "image sticking". This "vanishing" residual image is caused by the system, and does not represent a flaw. Therefore it can not be considered as a case for warranty claim.

Video cable

A high-quality 75Ω coaxial cable should be utilised for the connection of the video signal. Poor quality signal cable can result in strong disturbances and formation of shadows in the displayed image, as well as exceeding the permissible EMC level. The mechanical interlocks of the individual plug-and-socket connectors are necessary for perfect and safe operation of the device.

Control Unit

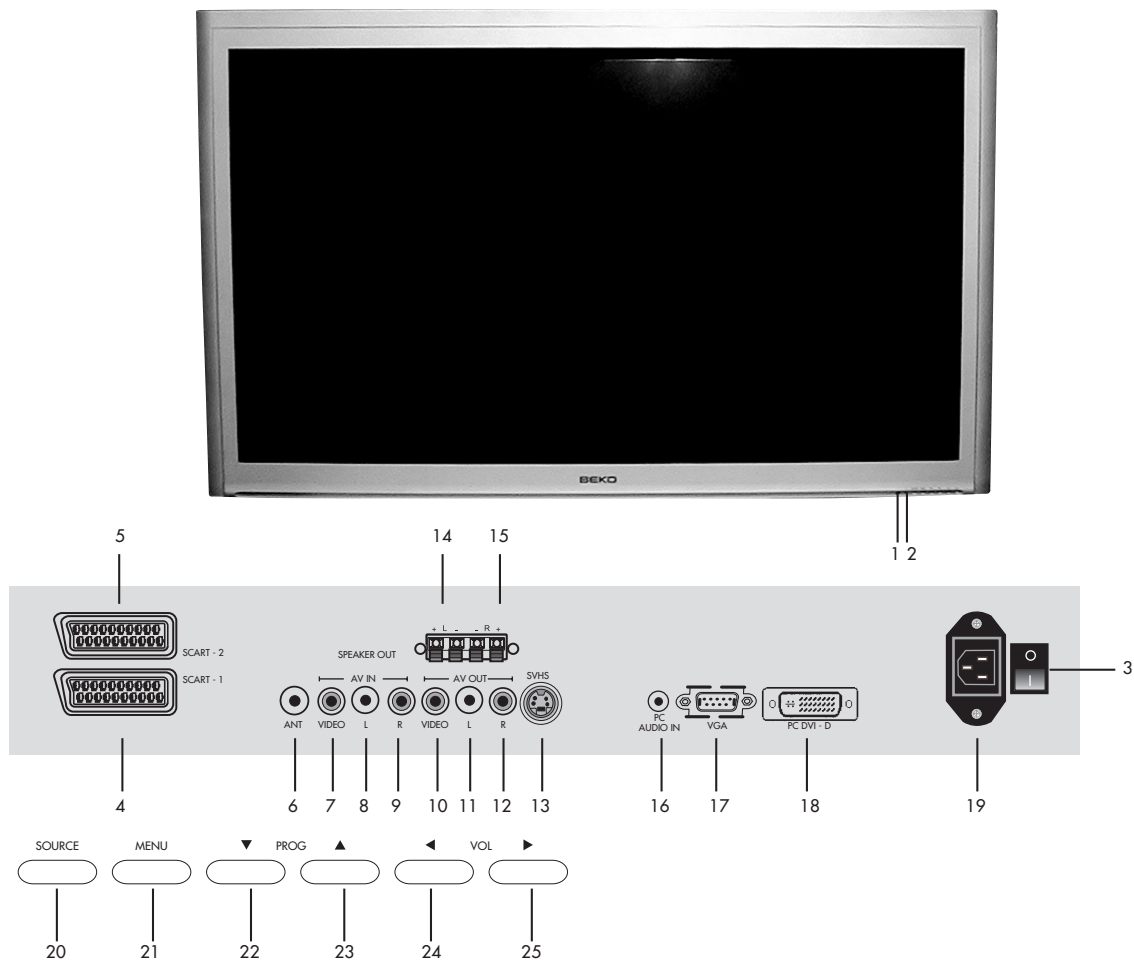

- | | |
|---|----------------------------|
| 1. Remote control | 14. Speaker out (L) |
| 2. Stand-by | 15. Speaker out (R) |
| 3. Power on / off | 16. PC sound input |
| 4. Scart 1 | 17. VGA |
| 5. Scart 2 | 18. DVI-D |
| 6. Antenna input | 19. Power Input |
| 7. Video input CINCH connector | 20. Source Select |
| 8. Audio RCA input (L) | 21. Menu button |
| 9. Audio RCA input (R) | 22. Program down |
| 10. Video output CINCH connector | 23. Program up |
| 11. Audio RCA output (L) | 24. Volume down |
| 12. Audio RCA output (R) | 25. Volume up |
| 13. S-VHS | |

Please note

- Do not use Video RCA and S-Video connections at the same time, otherwise they will effect the picture each other.
- RGB inputs from scart will give you better picture quality.

Remote control

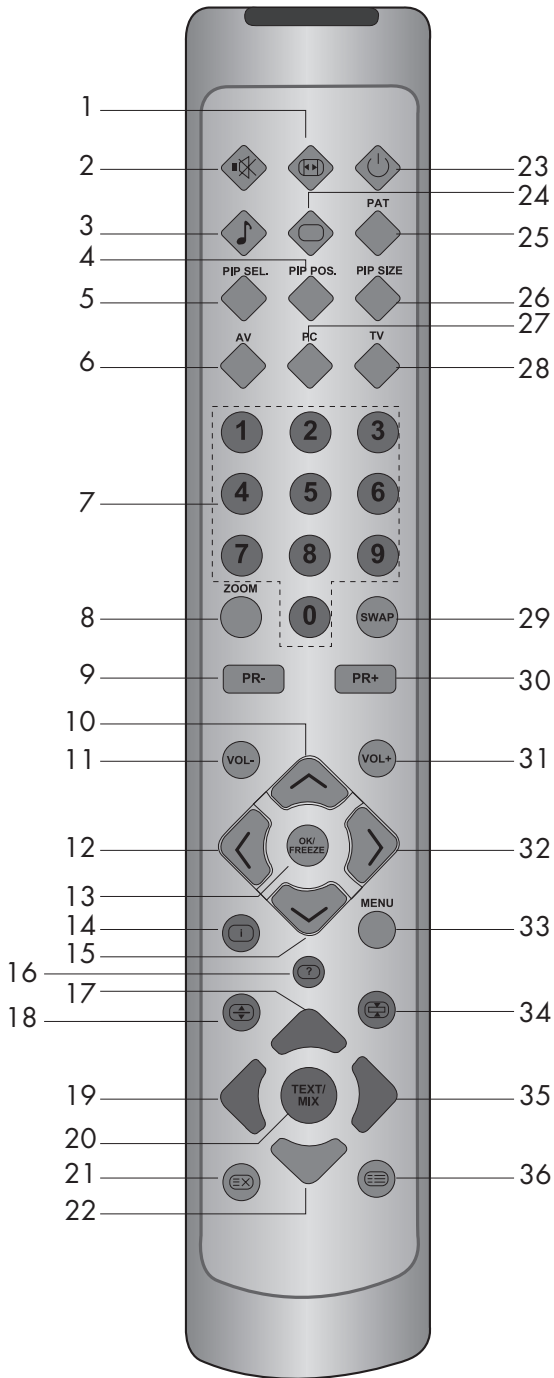



1. Picture Format choice button (⏏)
2. Temporary sound mute button (⏏)
3. Equalizer selection button (🎵)
4. PIP Position choice button
5. PIP/PAP On-Off button
6. AV modes select button
7. Numeric buttons
8. ZOOM mode choice button
9. Program down button (PR-)
10. Upward movement (⬆️) (Menu)
11. Volume down button (VOL-)
12. Left movement (⬅️) (Menu)
13. Confirmation and Temporary picture freezing button (Freeze) (OK/FREEZE)
14. Info / Txt index page button (⏏)
15. Down button (⬇️) (Menu)
16. Txt Question/Answer button (Reveal) (⏏)
17. Red Fastext Button (🔴)
18. Teletext enlarge button (Double) (⏏)
19. Blue Teletext Button (🔵)
20. Teletext / Mix choice buttons (TEXT MIX)
21. UPDATE Button (EX)
22. Yellow teletext Button (🟡)
23. Stand-by On/Off button (⏏)
24. Picture mode choice button (⏏)
25. PAT (Picture and Teletext) Mode On-Off button
26. PIP size button
27. PC mode input button
28. TV mode input button
29. Return to Selected Program Button (SWAP) (SWAP)
30. Program Up button (PR+)
31. Volume Up button (VOL+)
32. Right button (➡️) (Menu)
33. MENU button
34. Txt Stop Button (Hold) (⏏)
35. Green teletext button (🟢)
36. SUB PAGE Button (⏏)

Using the TV

Turning on for the first time and Tuning

TV controls

Temporary On-Off (STAND-BY)









When you press the red  stand-by button (temporary on-off function) located on the upper right hand side of your remote control of your television when it is switched on; indicator of your television will light red. To switch your television back on, either press the same button, any of the number buttons or one of the / buttons.

Caution!



If you are not going to use your television for a long period of time, make sure to switch it off from the main power button.

There are certain settings which you must make when setting up the television.

When you first switch it on, the Language menu appears.

1. Select the menu language by pressing  or .
2. Select Country with  or  and then select the country where you are located with  or .
3. Select Station search with  or  and press  to start the search.
 - The automatic station search starts. This may last a minute or longer, depending on the number of television stations received.
 - After the search, the station list appears. You can delete any stations which have been saved more than once. You can also move stations to a different preset position, and change or enter the station names.



Programme selection

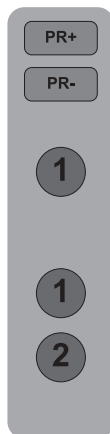

Press the / buttons on your remote control, or by selecting a numeric button in order to get the desired channel on your television. In order to select a program whose number is greater than 9, you can use the numeric buttons, punching in the desired numbers as required. For example, to select program 12, press the numeric buttons 1 and 2 one after another.



01 CNN	11 S05	21 S12
02 BBC P	12 S07	22 S13
03 SHOW	13 S09	23 S14
04 TRT 1	14 S10	24 S15
05 TRT 1	15 C05	25 S16
06 MTV	16 C07	26 S17
07 TRT 1	17 C10	27 S18
08 TV5	18 C11	28 S20
09 EUROS	19 C12	29 S21
10 S04	20 S11	30 S22
Skip		Name
Move		Delete

Mute







To temporarily mute the sound of your television, press the  button, where the  on screen display will appear on screen as an indication of the application.

When you press the same button again, the sound will return. During mute, when you press the  button the volume will decrease and automatically get out of the mute function, if you press the  button the volume will increase and automatically get out of the mute function.

Return to Selected Button Program (SWAP)

If you wish to return to the previous program that you were watching then you have the ability to return with a single function, by pressing the  button. Regardless of whether you are in AV, or any other program, by using the SWAP function allows you to swap between the program you were watching and the last selected program. If you hit the same button again, you will return to the program or AV you were watching before.

Control Menu

Press the  button. You will see the MENU with all the headings of the different controls on screen. The Right/left buttons / enable you to move between the different control menu title where you can indicate your choice by pressing the  or Up/down / button. In the event that you wish to exit the application at any given stage, simply press the MENU or TV button.



Tuning the television

You can either tune the programs automatically or manually storing them in your television.













Please Note



In the case that your television does not receive any broadcast signals for 5 minutes it will automatically go on stand-by. The 5 minute countdown OSD will be on screen.

Automatic tuning and storing of the television program channels with ATS

The ATS (Automatic Tuning System) on your television enables the automatic finding and sequencing of channels.

Sequencing is done according to the selected country channels, which broadcast Teletext and channel names; followed by all channels with Teletexts without channel names and then by channels without Teletext, to be concluded by foreign channels broadcasting Teletext with channel names.

Press the  button. Press the right move button  to select the Adjustment menu. You can reach this menu directly by pressing the Blue  button. Using the Up/down / buttons select the ATS line and press the , the screen will show the ATS menu. At the Country line select the country you want to watch by using the Right-left / buttons. Afterwards press the down  button to select the autoprogram heading and press the  or the Right/left / buttons. The screen will show a warning before the Automatic Tuning.

To start Autoprogram press the  button; the channels will be searched automatically and those with broadcasting will be saved from the first program into memory. At this point, the autoprogram warning menu appears showing an indicator that displays the present situation of the Automatic Tuning process. To stop the process at any given time, press the  button.

After the automatic search the screen will show the Program Table. The program numbers that have been stored are reflected in the Program Table, giving you the ability to assign any program number to the channel of your choice.



To quit the station list, press the  button.













Manual tuning and storing of the television channels



If you already know the Channel number





Press the  button. Press the right move button to select the Adjustment menu. You can reach this menu directly by pressing the  button.

Using the Up/down () / () buttons select the Set-Up line and press the  button, the screen will show the Set-Up menu. Select the program you want to Set-Up by using the Right-left () / () buttons or the numeric keys. Choose the system in which do a search among the system lines.



Enter the System line using the down button (). Here your TV can be set to one system, you can also select from () / () more than one systems. Move to the Band line using the down button (). Using the right-left () / () buttons on your remote control select "C" for the cable channels received through the "S" antenna.









Using the Up () button select the Channel line and enter the channel number by using the numeric keypad or right-left buttons. If the channel on screen is in the quality you desire and you want to store it into memory, select the Saving line with the down () button.

Afterwards press the  button, after a moment you will see a Stored sign. The channel will be stored according to the program number of your choice. In order to store other channels, simply repeat the above process. In the event that you wish to exit the Channel Settings, simply press the  button









If you do not know the Channel number

Press the  button. Press the right move  button to select the Adjustment menu.

You can reach this menu directly by pressing the  button. Using the Up/down / buttons select the Set-Up line and press the  button, the screen will show the Set-Up menu. Select the program you want to Set-Up by using the Right-left / buttons or the numeric keys. Choose the system in which to do a search among the system lines. Enter the System line using the down button . Here your TV can be set to one system, you can also select from / more than one systems.





(option) Move to the Band line using the down button .

Using the right-left / buttons on your remote control select "C" for the cable channels received through the "S" antenna. Use the down  button to select the Search line, and scan the channels using the right  button to increase and the left  button to decrease. Select the Saving line if you found the channel in the quality you desire.

Afterwards press the  button to store into memory. For the other channels using the Program No line, select the program numbers you want and repeat the same process.

If you want to Fine Tune or name the channel you found, please refer to the concerning sections.

Fine tuning

If the current channel requires fine tuning, select the Manual Fine Tuning bar by using the down  button in the Manual Tuning menu. Using the right-left movement / buttons on your remote control you will have the ability to get the exact quality of tuning required. Under normal conditions you will not need Fine Tuning. Your television will automatically lock channels, which need AFC values. However, in the event that the TV transmitters do not work, then you may need to use this process. For storing the settings to the memory press  button.



installation	
program no	1
system	B/G
channel	6
band	S
search	◀▶
fine tuning	0
store	

Program Table

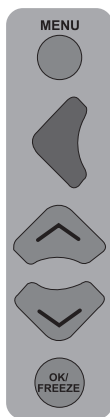

Press the button. Press the right move button to select the Adjustment menu. You can reach this menu directly by pressing the button. The screen will show the program table when you select the program table line with Up/down / and press the .

Switching the locations of the program channels that have already been stored

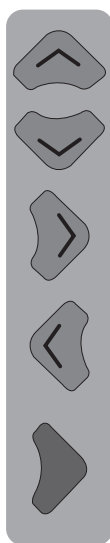

Select the program you want to switch by using the Up-down / or Right-left / button. Press the Green colored button.

number and name will appear green. Using the Up-down / or Right-left / buttons carry it to other program location you want to switch.

To finish the switching press the Green button. The first channel program number indicated can be moved to the second channel program number, which in turn moves the initial channel program number that has been indicated.

Deleting a program that has been stored



Select the program you want to delete by using the Up-down / button or Right-left / button. Press the Blue colored button. The screen will show the confirmation menu. You can press the Green button to delete or the Red button to exit the menu. When you press the Green button, the selected channel will be deleted and all following channels will move up in their position accordingly.

01 CNN	11 S05	21 S12
02 BBC P	12 S07	22 S13
03 SHOW	13 S09	23 S14
04 TRT 1	14 S10	24 S15
05 TRT 1	15 C05	25 S16
06 MTV	16 C07	26 S17
07 TRT 1	17 C10	27 S18
08 TV5	18 C11	28 S20
09 EUROS	19 C12	29 S21
10 S04	20 S11	30 S22
Skip	Name	
Move	Delete	

Skipping a program that has been stored

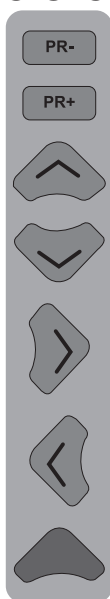

In the event that you do not wish to come across certain programs while going up and down between channels using the / buttons, then you can use the following function. Select the program to be stored by using the Up-down / button or Right-left / button. Press the Red colored button. To the right of the name of the program to be skipped will appear the letter "S" in red. You have the option of applying this method on more than one program channel.

In order to see the program numbers that are to be skipped, write down the number of the concealed program directly. To cancel the program skipping function press the Red button again. The red "S" to the right of the program name will disappear, and the skipping will be cancelled.

To name the programs

The programs in the table might show the channel names automatically with ATS, but could also show the channel number instead of the name.

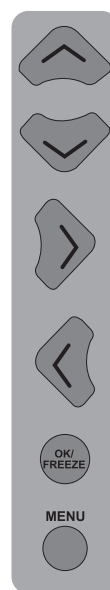

You can name any or all of the programs with names that have a maximum of five characters.

Select the program you want to name using the Up-down / or Right-left / buttons. Press the Yellow button. The screen will show the number, volume type and name information for the channel you want to name. Using the Up-down / buttons to select the desired letter, number or sign. the second letter use the Right-left / button and again use the Up-down / buttons to select the desired letter, number or sign. After entering all the letters press the to store the name.

To write names for any of the other programs, simply repeat the above procedure. In the event that you wish to exit the application, simply press the .

If no name is enter for any program, the program number will be automatically displayed.

The setup of your television: Setting up the Sound Menu

You can set the volume with the "VOL+" and "VOL-" buttons on the television or the (OK), (VOL-) buttons on the remote control.

You can control the other sound settings by entering the Sound menu. For this application all you need to do is press the (MENU) button of your remote control. Select the Sound menu with the direction (D) button. You can reach this menu directly by pressing the Red (▲) button. Select the functions from the headings in this menu.

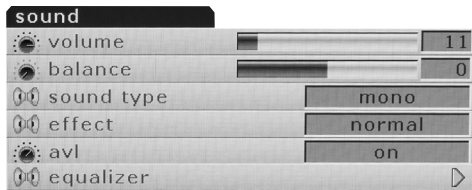

Effect: If you want to add depth to the sound of the program you watch, select Spatial with the (D) button.

Television transmitters have different sound levels. This can be noticed from the different volume levels that can be heard while switching from one program to another. Using the right/left movement (D)/(D) buttons switch to Open. The AVL (Automatic Volume Limiting) function maintains the same sound level as you switch from program to program. To cancel choose Closed.

Balance: To adjust the volume balance between the left and right speakers to the desired level, select the Balance bar using the down (V) button. Using the right/left movement (D)/(D) buttons adjust the balance.

Sound Type: The program you watch might be stereo or in two different languages. Using the right/left keys (D)/(D) in this menu you can select Mono/Stereo or Dual-I/Dual-II language.

Equalizer: Selecting the Equalizer mark press (OK) or (D) button. The equalizer setting function will be displayed. You can select with the right/left (D)/(D) buttons, pre-programmed, unchangeable sound enhancing Music, Sport, Cinema and Speech, User settings for the programs you are watching. These can be adjusted by you in the User selection. To adjust the User selection; select the User selection and press the (OK) button. You can adjust the frequency levels with the (V) and (▲) buttons. You can select 120Hz, 500Hz, 1.5KHz, 5KHz and 10KHz frequency bands with (D) and (D) buttons. Storing the adjustment levels in memory press the menu button to exit the user option. You can exit the equalizer function pressing the (MENU) button again.

Please note: You can choose the equalizer position directly from the (D) button of your remote control. You can exit the equalizer function pressing the (D) button at any time.

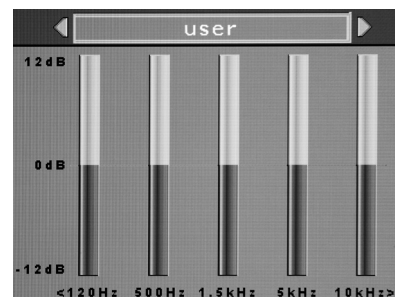

Picture Setup (Green button)

picture	
brightness	8
contrast	7
color	34
sharpness	2
noise reduction	soft
picture smart	user
picture format	auto

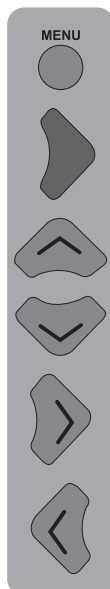

By pressing the (MENU) button on your remote control please enter the Picture menu. You can enter this menu directly by pressing the (▶). Select the setting function you want using the Up and down buttons (▲)/(▼) and adjust their levels with the right and left (◀)/(▶).

The picture brightness, contrast, color and sharpness levels can all be adjusted according to your desire. The changes you make in the picture settings will be automatically stored without any further transactions necessary being your Personal settings.

Static Reduction: Using this feature you can reduce static by selecting Normal, Soft, Softest, Sharpest and Sharp function.

Smart Picture: This is one of the pre-installed and unchangeable features, to select this feature use your (◀)/(▶) buttons. Soft, Natural and Rich are constant values. User are the values you stored into memory. Furthermore, you can select one of the non-adjustable default settings in the memory (Picture Mode) by pressing the "◆" button on your remote control.

Picture Format: This feature enables you to watch any broadcast image in the format you desire. These are; Auto, 16:9 Subtitle, Letterbox, 4:3 and Zoom. You can do the selection without entering the picture menu by using the "◆" format selection button.

Color Tint: When NTSC video is used in SCART, Color Tint settings can be made. If you do not use such a video type the Color Tint choice is not seen in the menu. If NTSC video is used in SCART this choice becomes active and can be seen in the menu.

Depending on the type of broadcast being transmitted, programmes can be viewed in a number of formats. Press the "◆" button repeatedly to select between **Zoom, Letterbox, Subtitle, Auto, 16:9, and 4:3.**

Please note: Whenever the MENU button is pressed the picture size setting will change while the menus are ON the screen. This is to ensure that the menus do not overlap the edges of the viewable area.

Zoom

This setting will enlarge the image to fit the screen by stretching the image horizontally, holding the correct proportions at the centre of the image. Some distortion may occur.

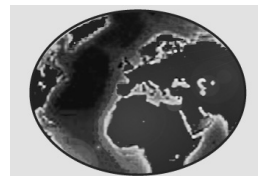

Letterbox

Use this setting when watching a widescreen DVD, widescreen video tape or a 16:9 broadcast (when available). Due to the range of widescreen formats (16:9, 14:9, 20:9 etc.) black bars may be visible on the top and bottom of the screen. Letterbox format removes black bars or makes it much less visible.



Subtitle

When subtitles are included on a letterbox format broadcast, this setting will raise the picture to ensure that all the text is displayed.

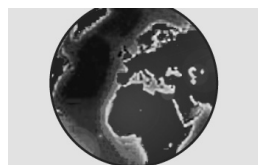

Auto

Some channels may send automatic screen formatting. If you wish to switch automatically to this format select Auto. The TV will automatically switch to detected format from the scart inputs.

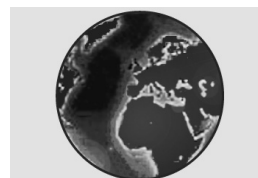

16:9

Use this setting when watching a widescreen DVD, widescreen video tape or a 16:9 broadcast (when available). Due to the range of widescreen formats (16:9, 14:9, 20:9 etc.) black bars may be visible on the top and bottom of the screen.

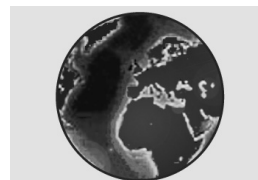

4:3

Use this setting to view a true 4:3 broadcast.

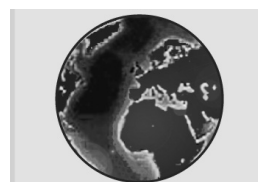

Using the special functions to change the size of the displayed image (i.e. changing the height/width ratio) for the purposes of public display or commercial gain may infringe on copyright laws.

Features Menu (Yellow Button)

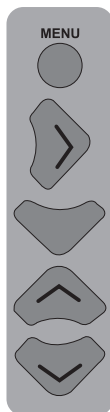

Press the button on your remote control. Select the Function menu line with the button.

You can reach this menu directly by pressing the Yellow button. You can select the headings you want to adjust in this menu by using the Up/down / buttons.

Child Lock: If you switch this feature On, the buttons on the TV will not work when the TV is in Stand-by mode or on and screen will show a Child Lock warning.

Language: Select the menu language line and press or the right button. The screen will show the menu languages. Select the desired language using the Up-down / and Right-left / buttons. Press the button again. Your television will now feature the language you have chosen for all the adjustment indicators.

English	Norsk	Česky
Deutsch	Deens	Slovenščina
Français	Dutch	Hrvatski
Italiano	Suomi	Magyar
Español	Polski	Româna
Português	Ελληνικά	Српски
Türkçe	Русский	Slovensko
Svenska	עברית	Български
Menu: Back		TV: Exit

Menu Background: Using this feature you can adjust the background of the viewable menus and other OSDs as Transparent or Opaque.

Stand-by Control: Your television features an automatic stand-by feature which can be enabled between 15 and 120 minutes. If you want your television to automatically go into stand-by, please select the Stand-by Control line. Select the desired duration with the Right and left button.

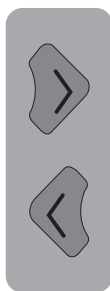

At the end of the chosen duration the screen will show a 30 second countdown before switching off the screen and entering into stand-by. To cancel the automatic stand-by select "0" at the Stand-by Control.

VCR mode: Using this feature you can avoid image distortions from the device or the magnetic tape while watching. For this you have to switch the VCR mode to ON.

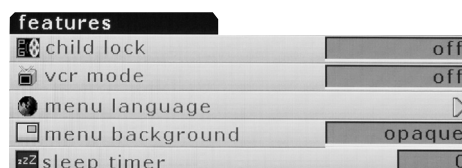

Please note: This feature is only active for the AV inputs. This feature will not be seen in Function menu while watching programs or in PC mode.

This feature becomes automatically active in the "0" numbered program. When you store the "0" numbered channel as video device antenna output, you will be able to avoid image distortions from the device or the magnetic tape while watching.

ZOOM: To activate this feature you have to press the button on your remote control while watching a program. When you enter this menu you will see in the lower right corner of the screen the Zoom sub-menu. Using the Up/down / buttons you can enlarge or shrink the image in 16 steps. During the Zoom process the image will be enlarge focused on the center.



want to move the image up/down or right/left / press the button on your remote.

buttons to move around. In the event that you wish to exit the Zoom menu, simply press the button. **Please Note:** The Zoom function is not available during PIP.

FREEZE: This feature enables you to freeze the image of a program you are watching. For this use the (OK/FREEZE) button on your remote control, make sure you don't have any menus on screen. The image will be frozen until you press the button the second time.

Please Note: The Freeze function is not available during PIP.

PIP Usage (Picture in Picture) Feature:

Press the (PIP SEL.) button on your remote control.

The screen will show the PIP window selection menu.



In this menu select either Picture in Picture (PIP) or Divided Screen (PAP) and press the (OK/FREEZE) button. According to the selection a picture will open in main picture and will position itself in the lower screen.

If you choose Full Screen mode PIP will go out. In the event that you wish to exit PIP mode, simply press the (PIP SEL.) button.

Note:

1) From the program you are watching or from AV mode, you can open the PIP window, and change the other programs through the main image.

2) You can use PIP in PC or DVI mode.

3) The same AV input cannot be watched with PIP and the main image.

PIP Position

This feature enables you to position your PIP window. For this press the (PIP POS.) button, while having PIP on screen, to bring the PIP Position menu on screen.

Press the right/left (LEFT/RIGHT) buttons to make the PIP Position selection. After you positioned your PIP window you can exit the menu by pressing the (MENU) button on the remote control.

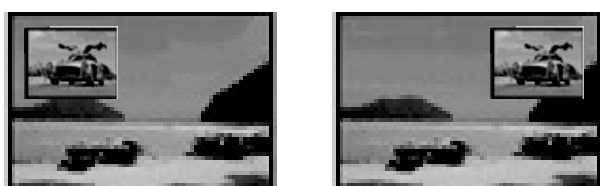

PIP Size

This feature enables you to resize your PIP window. For this press the (PIP SIZE) button, while having PIP on screen, to bring the PIP Size menu on screen.

Press the right/left (LEFT/RIGHT) buttons to make the PIP Size selection. After resizing your PIP window you can exit the menu by pressing the (MENU) button on the remote control.



PAT Mode

While watching TV you can enter the PAT (Picture and Teletext) mode by pressing the (PAT) button on your remote control. This feature enables you to read the program's teletext, if available, while watching the very same program.

To exit this mode press the (PAT) button on your remote control again.

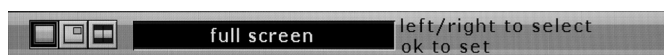

Using Teletext

Teletext is an information system that displays text on your TV screen. Using the teletext control buttons you can view pages of information that are listed in the teletext index.

Please Note

No on screen display is available in text mode. The contrast, brightness and colour cannot be changed but the volume control is still available.

To enter Text mode

Please Note

Make sure the TV channel you are watching transmits teletext.



Press the (TEXT/MIX) button. The text page will appear, normally the index page.

To exit Text mode



Press the (TV) button. The screen will return to the channel you were watching.

To select a page of text



Find the number of the page in the index and enter it using the Numeric buttons. The number of the page will appear in the top left hand corner of the screen.

The page counter will search for your page. When it finds it, the page will be displayed.

To move to the next page of text press the (PR+)/(UP) button.

To move to the previous page press the (PR-)/(DOWN) button.

To return to the index page press the (I) button.

TV/Text mix

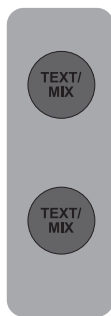

To view a TV programme whilst in text mode, press the (TEXT/MIX) button. The text will be superimposed over the TV programme.

Press the (TEXT/MIX) button again to return to the channel you are watching.

Page search whilst watching TV



In Text mode press the (EX) button. The TV will return to TV mode with the text page number in the top left hand corner of the screen.

Enter the page number you want using the Numeric buttons.

The top line of the text page will appear whilst the text searches for your page. When the page is found the number will remain in the top left hand corner of the screen.

Press the (EX) button to view your selected page of text.

Double height text



If you have difficulty reading the text on the TV you can double the height of the text.

Press the (DOUBLE HEIGHT) button. The top half of the page will be displayed in double height text.

Press the (DOUBLE HEIGHT) button again. The bottom half of the page will be displayed in double height text.

Press the (DOUBLE HEIGHT) button again to return to the full page.

Page Stop

If the page of text you have selected contains sub pages, these sub pages will automatically be displayed in order with a delay to allow you to read the page.



To stop the move to the next sub page press the (⏏) button.



To continue moving through the sub pages press the (⏏) button again.

To select a sub page

If the page of text you are viewing contains sub pages, the number of the sub page you are on and the total number of sub pages is displayed on the right of the screen i.e. 1/7.



To select a sub page press the (⏏) button. Press the green button to select next sub-page or press the red button to select the previous sub-page.



Enter the number of the sub page, using the Numeric buttons in the format S0001 for sub page 1.



The teletext will search for the sub page. This may take some time. To return to the TV whilst the teletext is searching press the (⏏) button.

When the page number is found it will appear in the top left hand corner of the screen.



Press the (⏏) button again to view the text page.

To reveal information



Press the (Ⓜ) button to reveal concealed information (quiz answers etc.).



Press the (Ⓜ) button again to cancel the information again.

Clock



Press the (Ⓜ) button, whilst watching a TV program, to display the time.

Fasttext

At the bottom of the teletext screen is a row of subject headings in red, green yellow and blue.

The remote control has a row of coloured buttons corresponding to the row of coloured subjects on the screen.

Pressing one of the coloured buttons will take you directly to the page corresponding to the subject heading.

Connecting external equipment

AV Inputs:

Press the (◆) button on your remote control. You will enter the Source menu from where you can elect the screen input mode. Here select the input you desire.

TV: To move to TV mode while in AV modes, move on to the selection and press the (OK/RECALL) button.

Scart1: To be able to view the broadcasting images from the device connected to Scart1, move on to the selection and press the (OK/RECALL) button. (If the connected device has an RGB output, you will be able to watch it over Scart.)

Scart2: To be able to view the broadcasting images from the device connected to Scart2, move on to the selection and press the (OK/RECALL) button. (If the connected device has an RGB output, you will be able to watch it over Scart.)

SVHS: To be able to view the images from the device connected to the S-Video input, move on to the selection and press the (OK/RECALL) button.

AV: To be able to view the images from the device connected to the RCA (Chinch) input, move on to the selection and press the (OK/RECALL) button.

PC: To be able to view monitor images in PC mode, move on to the selection and press the (OK/RECALL) button.

DVI: To be able to view images in DVI mode, move on to the selection and press the (OK/RECALL) button.

Connecting a video recorder

① Via SCART

Make sure the TV and video recorder are both switched off.

Plug one end of the SCART lead (not supplied) into the back of the video recorder and the other end into one of the SCART sockets on the back of the TV.

Switch on the video recorder and the TV.

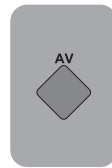

Press the (◆) button on the remote control to select SCART1 or SCART2 to correspond with the SCART socket you are using on the back of the TV.

Please note: You can connect RGB external equipment via Scart. It is necessary to you use a full Scart cable for this purpose.

Select the video output of the external device by using its menu, and set to RGB.

② Via RCA lead (optional)

Make sure the TV and video recorder are both switched off.

Plug one end of the RCA lead into the video and audio out sockets on the back of the video recorder and plug the other end into the video and audio in sockets of the TV.

If the sound is mono, use the Audio Input L. and in the SOUND menu select the MONO feature.

3 Via aerial socket

Make sure the TV and video recorder are both switched off.

Unplug the aerial lead from the TV and plug it into the aerial socket on the video recorder.

Plug a coaxial plug into the RF out socket on the rear of the video recorder and plug the other end into the aerial socket on the TV.

Switch on the video recorder and the TV. If your video recorder has a test signal, switch it on. (Refer to the video recorder user guide).

See 'Tuning the TV' and carry out the tuning procedure for the video recorder test signal. Select a programme number 0.

4-5 Via RCA lead and S-Video socket

You can also connect it through the S-Video socket of the TV.

Plug the S-Video plug into the S-Video socket and the audio leads into the audio sockets.

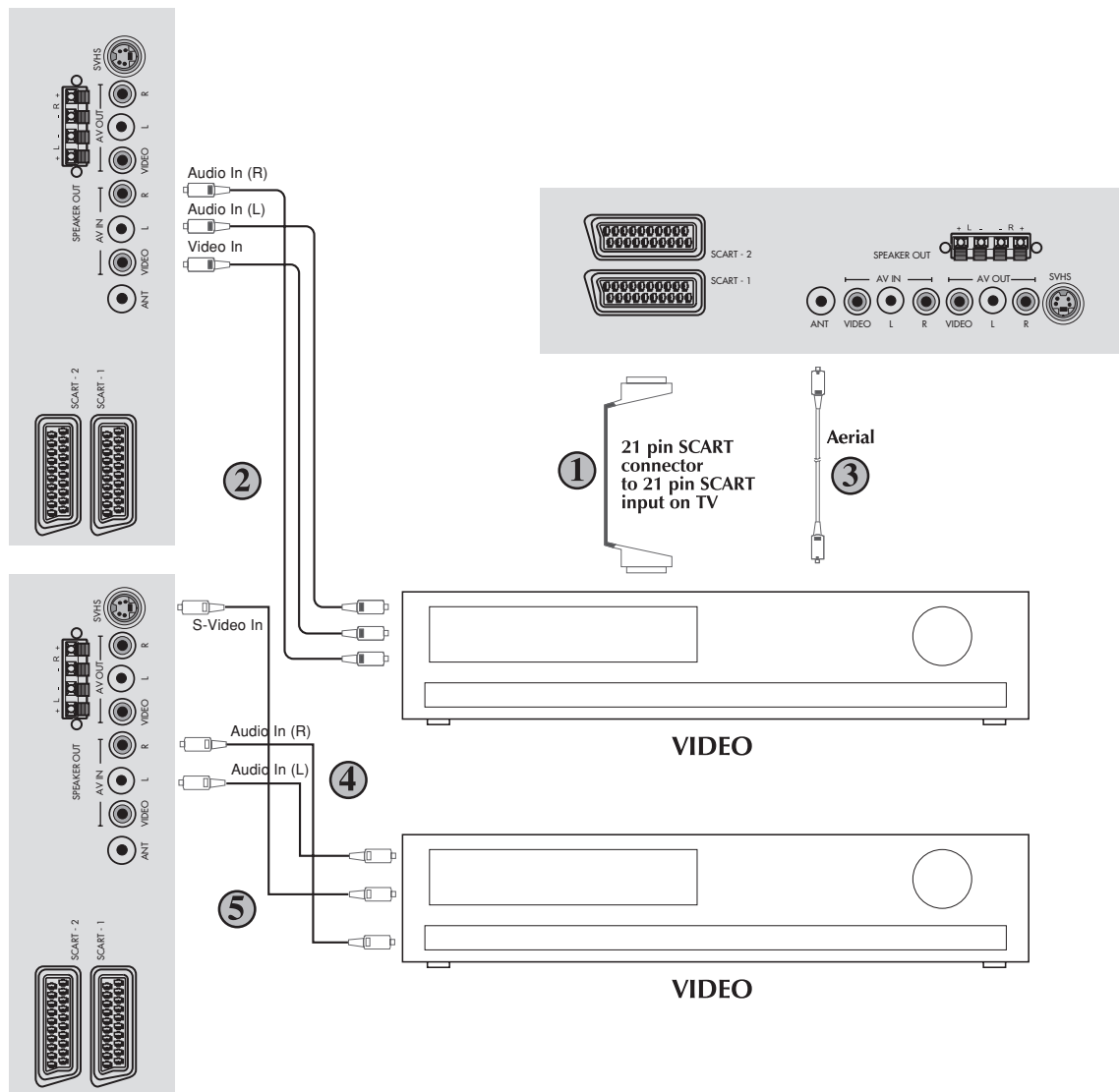

Connecting a DVD player

① Via SCART

Make sure the TV and DVD player are both switched off.

Plug one end of the SCART lead (not supplied) into the back of the DVD player and the other end into the SCART socket on the back of the TV.

Switch on the DVD and the TV.

② Via RCA lead

Make sure the TV and DVD player are both switched off.

Plug one end of the RCA lead into the video and audio out sockets on the back of the DVD player and plug the other end into the video and audio in sockets of the TV.

③ Via RCA lead and S-Video socket

You can also connect it through the S-Video socket of the TV.

Plug the S-Video plug into the S-Video socket and the audio leads into the audio sockets.

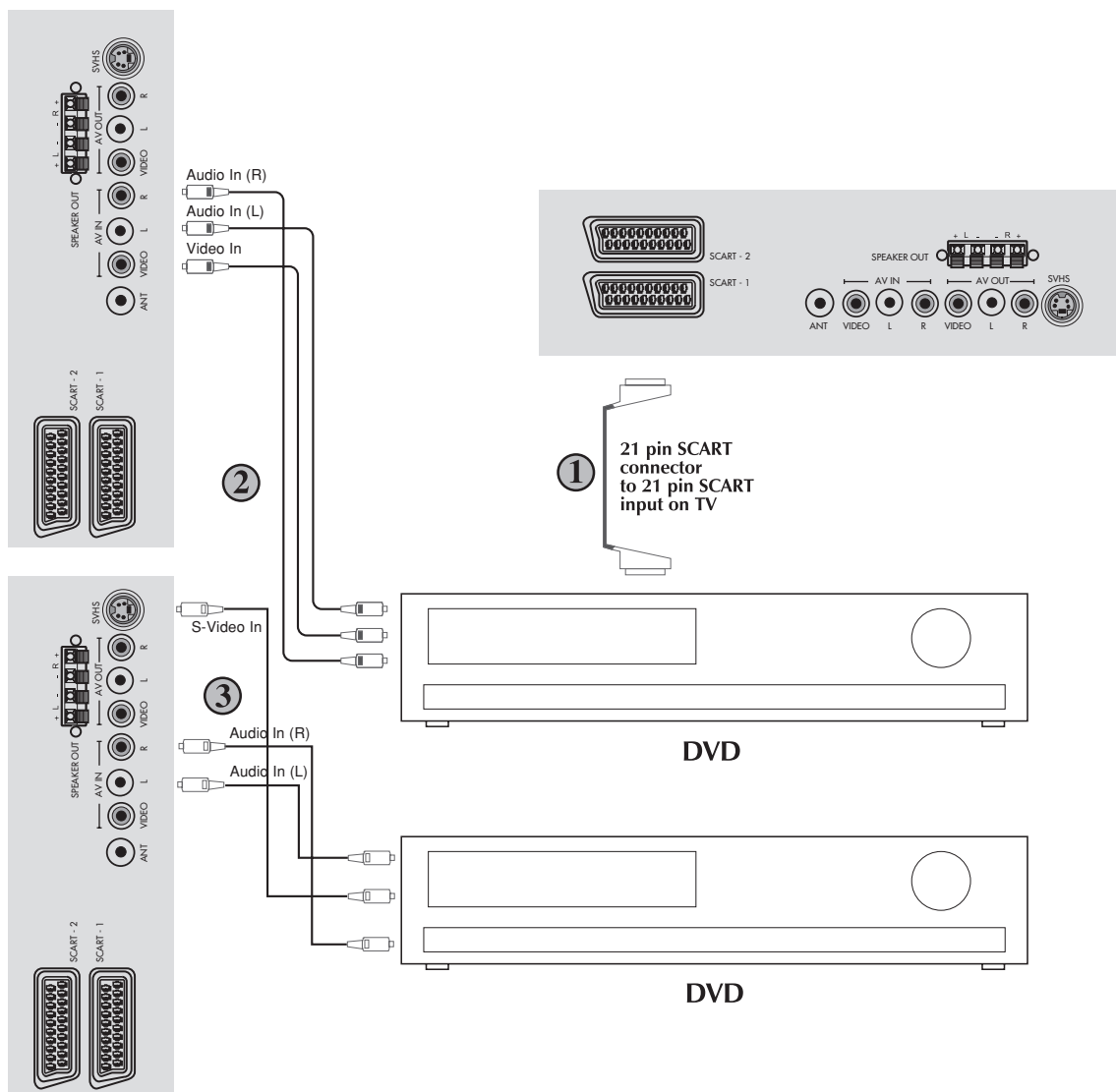

Connecting a decoder

Via SCART

Make sure the TV and decoder are both switched off.

Plug one end of the SCART lead (not supplied) into the back of the decoder and the other end into the SCART on the back of the TV.

Switch on the decoder and the TV.

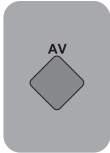

Press the (AV) button on the remote control to select SCART1.

② Via RCA lead

Make sure the TV and decoder are both switched off.

Note: For Decoder connection Via RCA lead your Decoder device must have the tuner built in.

Plug one end of the RCA lead into the video and audio out sockets on the back of the decoder and plug the other end into the video and audio in sockets on the TV.

Connecting DVI-D

Your TV has DVI-D input socket. You can connect any device such as PC etc. which has DVI digital out using the proper cable. At the same time you can listen to the sound from the connected device. PC or DVI use a special cable to PC-DVI/AUDIO IN input at the back of your TV.

AV Outputs

You can connect any device which is proper to Phono inputs via Phono Video and Audio Outs at the back of your TV set using proper AV cable (not available with the set).

Any programme or AV input which is seen on the main screen other than S-VHS, PC or DVI (which is option) is available as picture and sound signals at Phono Video/Audio outs.

Scart sockets at the back of your TV set are always give the signals of selected programme from the set Tuner.

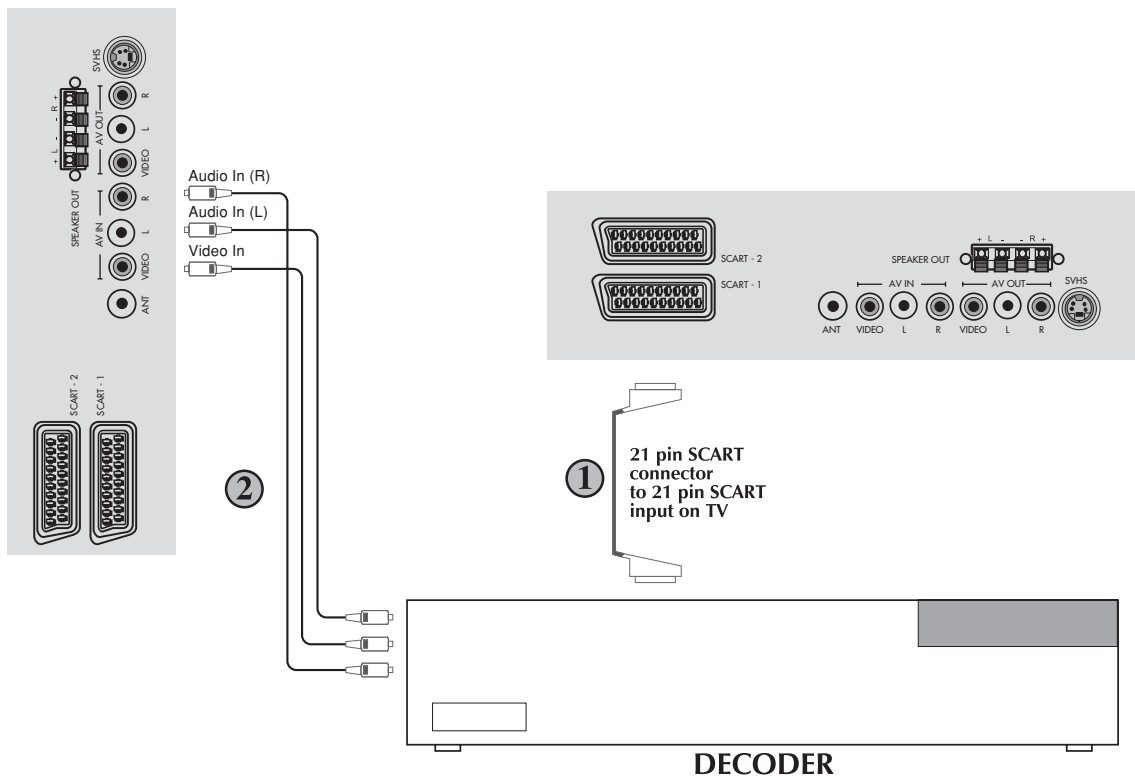

INTRODUCTION

Because your 42" 16:9 PDP-TV equipment is provided with VGA inputs, it may be used as a PC monitor as well. (Pug&Play)

Connecting PC:

Connect your PC through the D-Sub connector and an appropriate cable (not included with your TV) to PC-IN input the back of the TV. Again using an appropriate cable you can connect your PC sound output to the PC-DVI / AUDIO IN input on the back of the TV and listen to sound.

Transition to the PC mode

In order for the PDP to switch to the monitor (PC) mode, you can press the (◊) button on your remote control. In order to switch from the PC mode back to the TV mode, use the (◊) button on your remote control.

PC Input Settings

You can enter the picture setting menu by pressing the (MENU) or the (▶) while in PC mode. In order to make the necessary adjustments in this menu, you can use the right-left, up-down direction (◀)/(▶) (▲)/(▼) buttons on your remote control.

Here you can make adjustments to Brilliance and Contrast as well as other adjustments for the monitor listed below.

H.Position: Horizontal position setting

V.Position: Vertical position setting

PHASE: Using the Right/left (▲)/(▼) buttons you can adjust color and shape.

Picture Format: You can select your PC viewing image from auto, 4:3 or one-to-one.

You can make your choices without entering the picture menu by using the format button on your remote control.

Automatic Configuration: The most suitable geometric settings in accordance to the entry mode is configured by this function. For this application, choice the AUTOMATIC CONFIGURATION option and press the (OK/FREEZE) button.

In PC mode you are able to use ZOOM and PIP as mentioned in the sections above. You can adjust the volume of the device you connect to the Audio-In input at the back of the TV by using the (VOL+)/(VOL-) or (MUTE) buttons.

Transition to the DVI mode

Connect your PC or digital video device using its connector and an appropriate cable (not included with your TV) to the DVI input at the back of your TV. Again using an appropriate cable you can connect your PC or sound device output to the PC-DVI / AUDIO IN input on the back of the TV and listen to sound.

Please Note: To be able to view images in DVI mode your computer must have a graphics card with DVI output.

Adjustments in DVI mode are the same as in PC mode. However automatic configuration will not function in this mode.

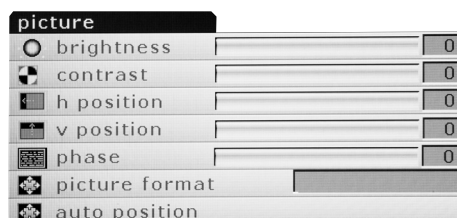

Connecting TV with video and satellite/digital receiver

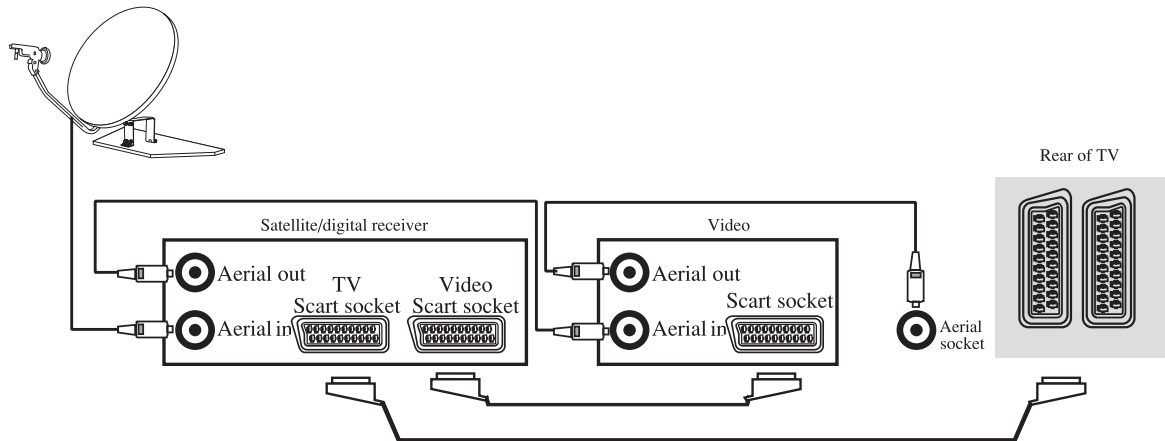

Connecting TV with camcorder

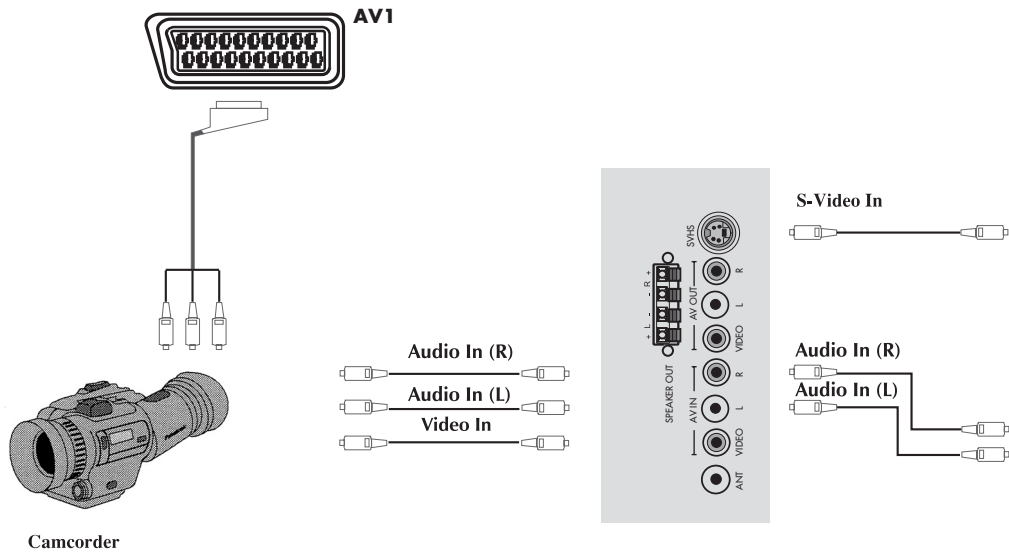

Connecting TV games and computer

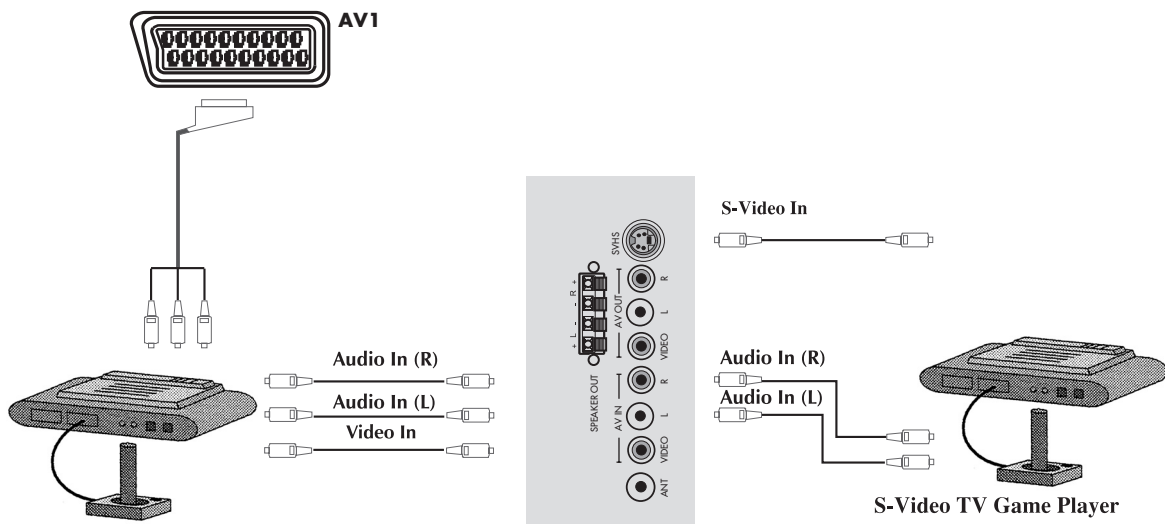

Technical specifications table

Panel size/typee	42" 16:9 Plazma TV
Sound Output (%10 THD)	2X7 W
Power consumption	275 W
Stand by Power consumption	6 W

General technical specifications

Power Supply

AC:	230 V 50 Hz
Number of preset programmes:	100
RF Aerial input:	75 ohm (unbalanced)
Speaker empedance:	4 ohm
Sound Systems:	Mono/Stereo/NICAM
Batteries:	2xUM-4, IEC R03 or AAA 1.5 V
Receiving channels:	VHF (Band I Channels 2-4)
.....	VHF (Band II Channels 5-12)
.....	UHF (Channels 21-69)
.....	Cable TV (S1-S20/S21-S41)
Receiving Broad system:	Pal BG
	Pal SECAM BG
	Pal SECAM BG DK/DK'
	Pal SECAM BG LL'
	Pal I

Panel Power Supply

L6B Chassis Power Supply

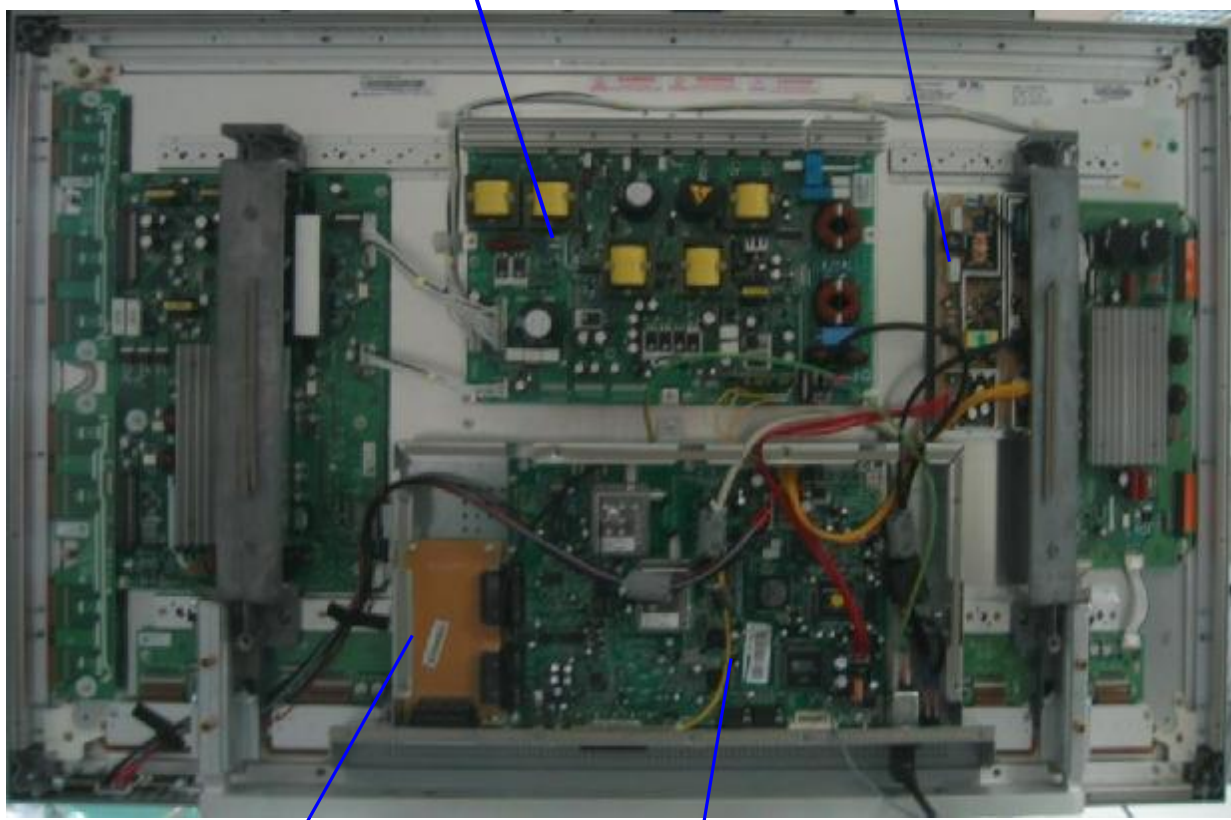

Scart Adaptor

L6B Chassis

Note: You can find more detailed informations regarding panel and panel modules in the panel sections of the service manual.

L6B CONNECTION DIAGRAM

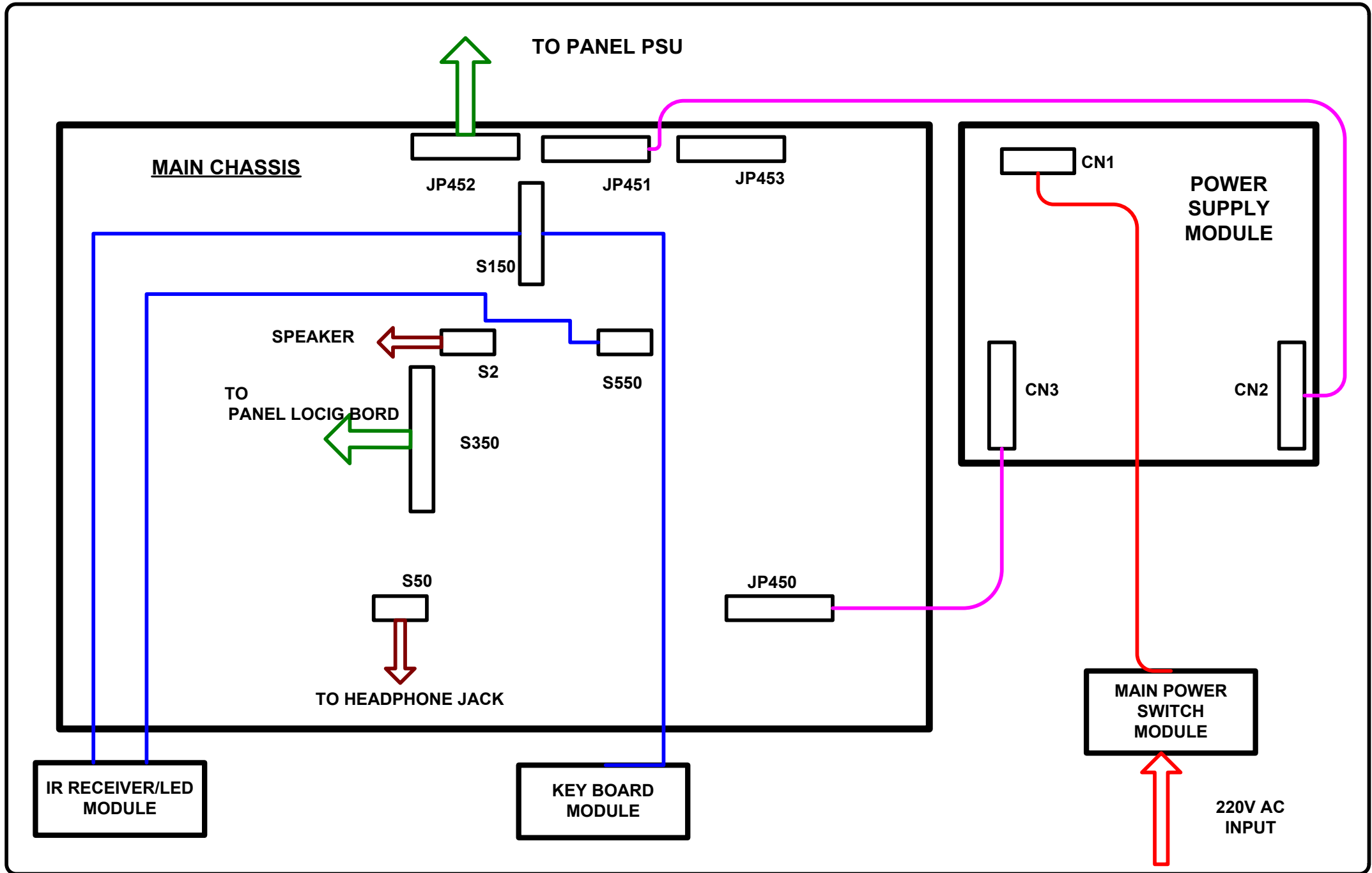

L6B BLOCK DIAGRAM

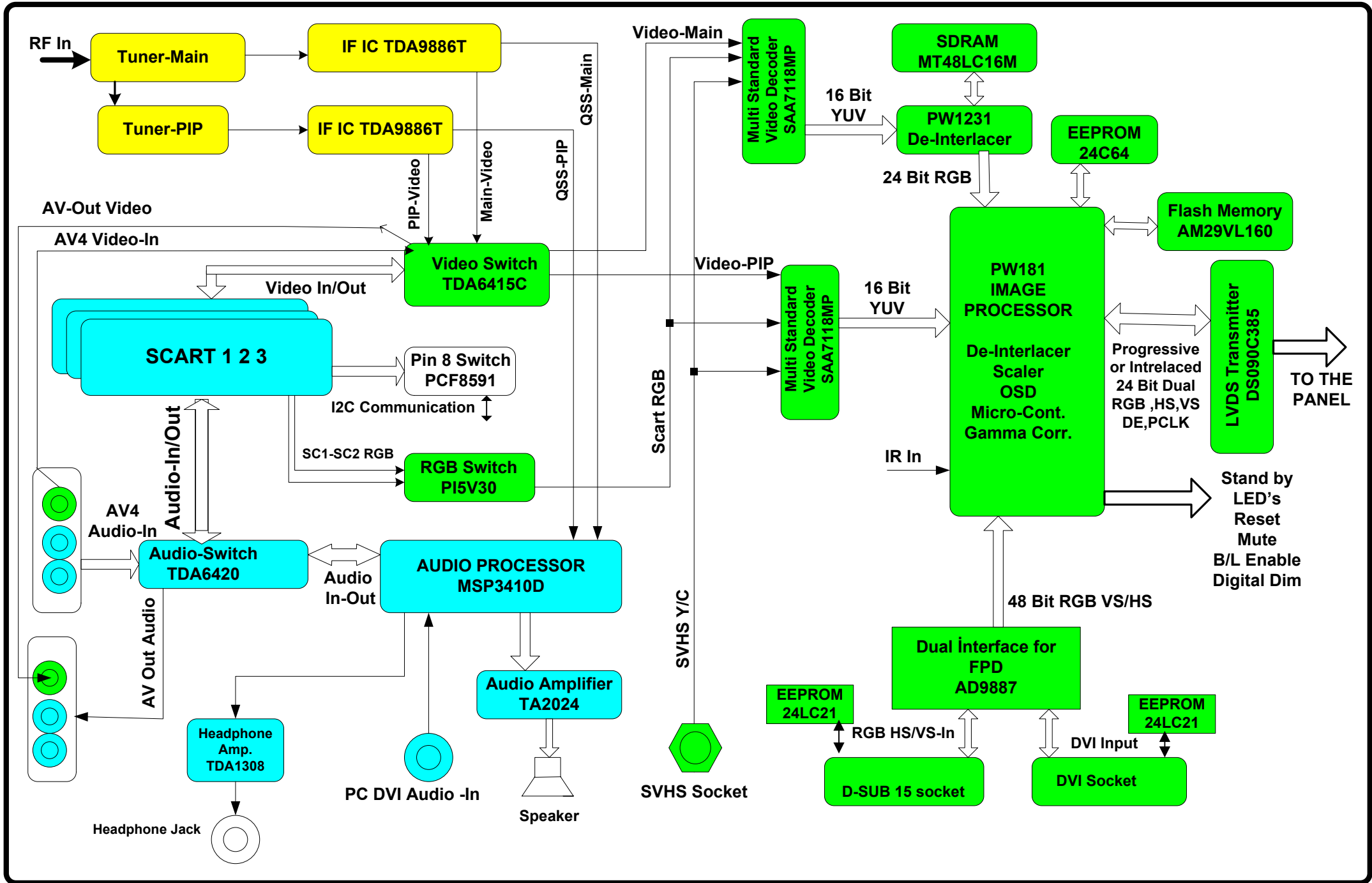

L6B POWER SUPPLY BLOCK DIAGRAM (MAIN CHASSIS)

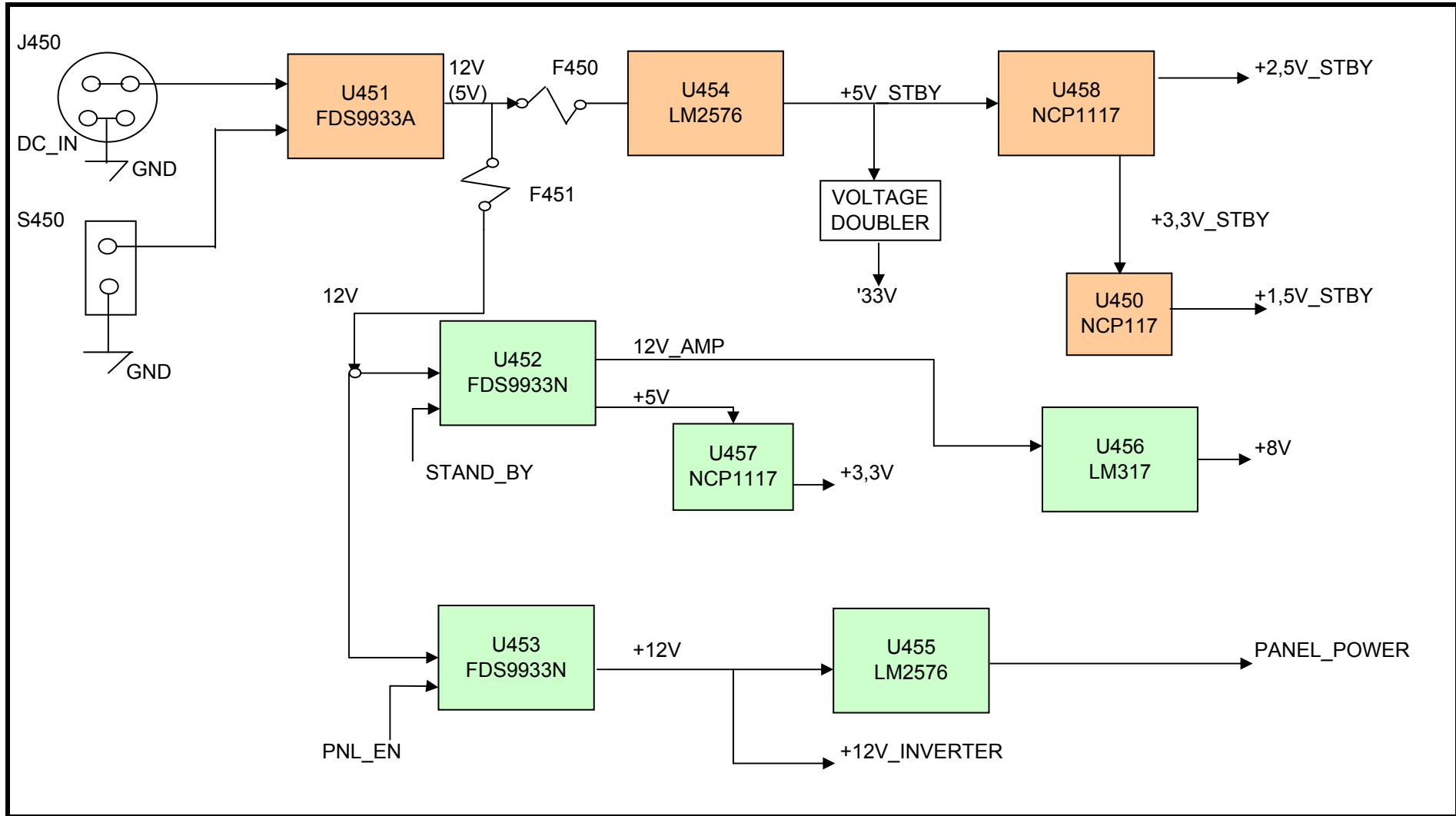

L6B SERVICE MENU

1. Activating the Service Menu

When the menu is on the screen press '9', '3', '0', '1' on the remote controller. This will activate the service menu.

2. Service Menu Structure

The service menu has three items: display, calibre and version

2.1 Display

Display item has seven options:

- a- Panel
Panel option gives information about the current panel resolution. It is a read only option and can not be set.

- b- Factory mode
Used during production, keep "off".

- c- Scart prescale
Scart prescale option sets the prescale values for the input sounds entering the scart input of the MSP(Micronas Sound Processor). Changing this value you can adjust the level of the output sound going to loudspeakers for all the sources except the Tuners. The range is between 0 and 100.

- d- nicam prescale
Nicam prescale option sets the prescale values for the Nicam standard sounds for tuner inputs. Changing this value you can adjust the level of the output sound going to loudspeakers for Nicam sounds entering the analog sound input of MSP. The range is between 0 and 100.

- e- fm/am prescale
fm/am prescale option sets the prescale values for the FM/AM standard sounds for tuner inputs. Changing this value you can adjust the level of the output sound going to loudspeakers for FM/AM sounds entering the analog sound input of MSP. The range is between 0 and 100.

- f- Agc(Automatic Gain Control) adjust
Agc adjust option sets the input voltage going to IF decoder AGC pin. Changing this value you can adjust this voltage for optimum Tuner performance. The range is between 0 and 31.

- g- R/G/B Brightness/Contrast: These are used for color bias adjustment. The range is Between 0 and 255

2.2 Calibre

Calibre item has nine options:

a- video format

Video format option force the video format to the desired format. Selectable formats are Auto, Pal, NTSC and SECAM.

b- colorspace

Colorspace option gives the information about the video input colorspace input to PW181 IC. Do not change this value unless an error occurred in the colors displayed.

c- test pattern

This option activates the internal pattern of PW181 IC. There are 3 choices: none, vert bars, solid color. None will deactivate the internal pattern. Vert bars choice activates the bar pattern for the selected color component. Solid color activates the solid pattern with one color selected in color component and also you can change the level of the color by solid field level.

d- Color components:

This option selects the color for the internal pattern of PW181 IC. There are 4 choices: all, red, green and blue. If you choose all, you can see the white pattern and if you choose one of the other choices you can see the test pattern with the selected color.

e- solid field level

This option will adjust the level of the colors for the test pattern. The range is between 1 and 64.

f- Initial ATS

This option will enable or disable the Initial setup for the TV. Setting this option to On, the TV will open from the Quick setup menu. Setting this option to Off will disable this option.

g- factory reset

Factory reset option executes a reset operation for the NVRAM. Pressing OK when this option is selected will erase the NVRAM and load default values to NVRAM.

h- dpms

This option selects the Power option for the TV. Setting this option to On the TV will switch to the last state for power on transition. Setting this to Off will disable this option and the TV will always switch to Stand-by state while power on transition.

i- osd timeout

This option sets the OSD timeout for the main menu structure. Selections are 5, 15 and 60 secs. The default is 60 sec.
(backlight:Not used in this product.)

2.3 Version

This item gives the information about the version of the software. Also you can see the last modified time for the GUI(graphical user interface).

BUS-CONTROLLED VIDEO MATRIX SWITCH

- 20MHz BANDWIDTH
- CASCADABLE WITH ANOTHER TEA6415C (INTERNAL ADDRESS CAN BE CHANGED BY PIN 7 VOLTAGE)
- 8 INPUTS (CVBS, RGB, MAC, CHROMA, ...)
- 6 OUTPUTS
- POSSIBILITY OF MAC OR CHROMA SIGNAL FOR EACH INPUT BY SWITCHING-OFF THE CLAMP WITH AN EXTERNAL RESISTOR BRIDGE
- BUS CONTROLLED
- 6.5dB GAIN BETWEEN ANY INPUT AND OUTPUT
- -55dB CROSSTALK AT 5MHz
- FULLY ESD PROTECTED

DESCRIPTION

The main function of the TEA6415C is to switch 8 video input sources on the 6 outputs.

Each output can be switched to only one of the inputs whereas but any same input may be connected to several outputs.

All the switching possibilities are controlled through the I²C bus.

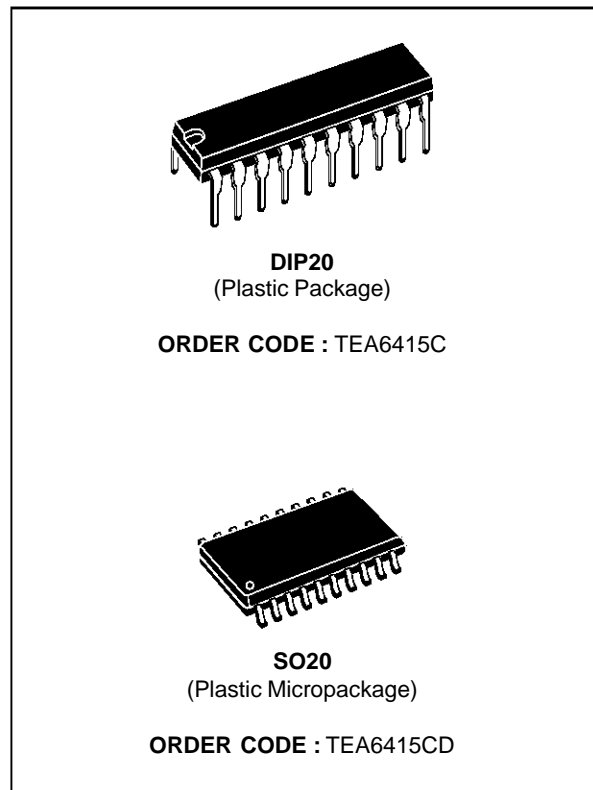

PIN CONNECTIONS

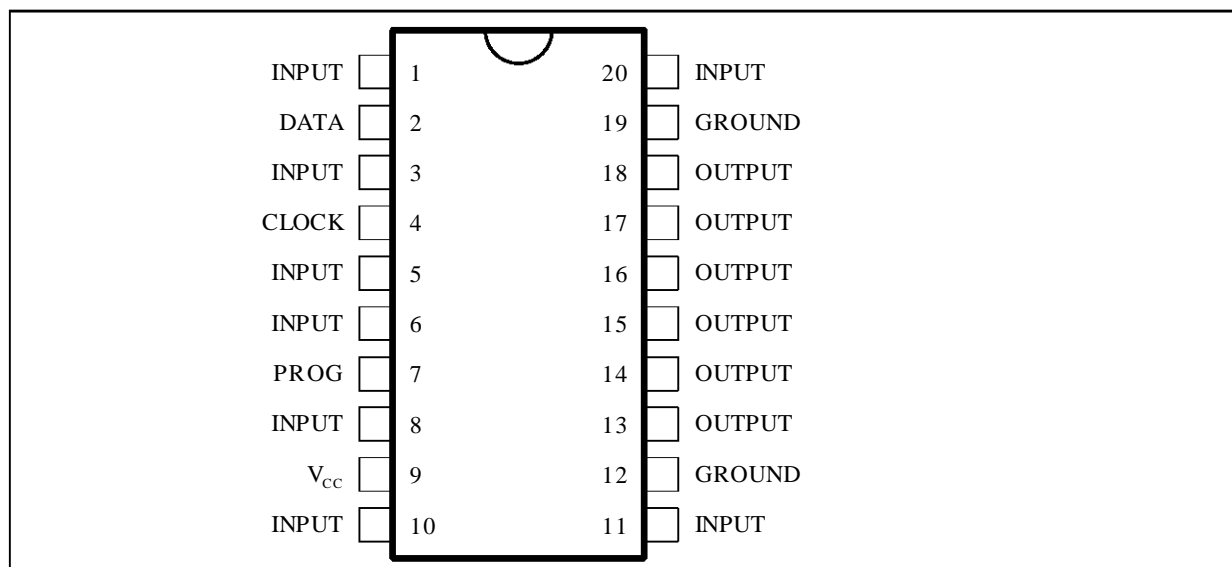

BLOCK DIAGRAM

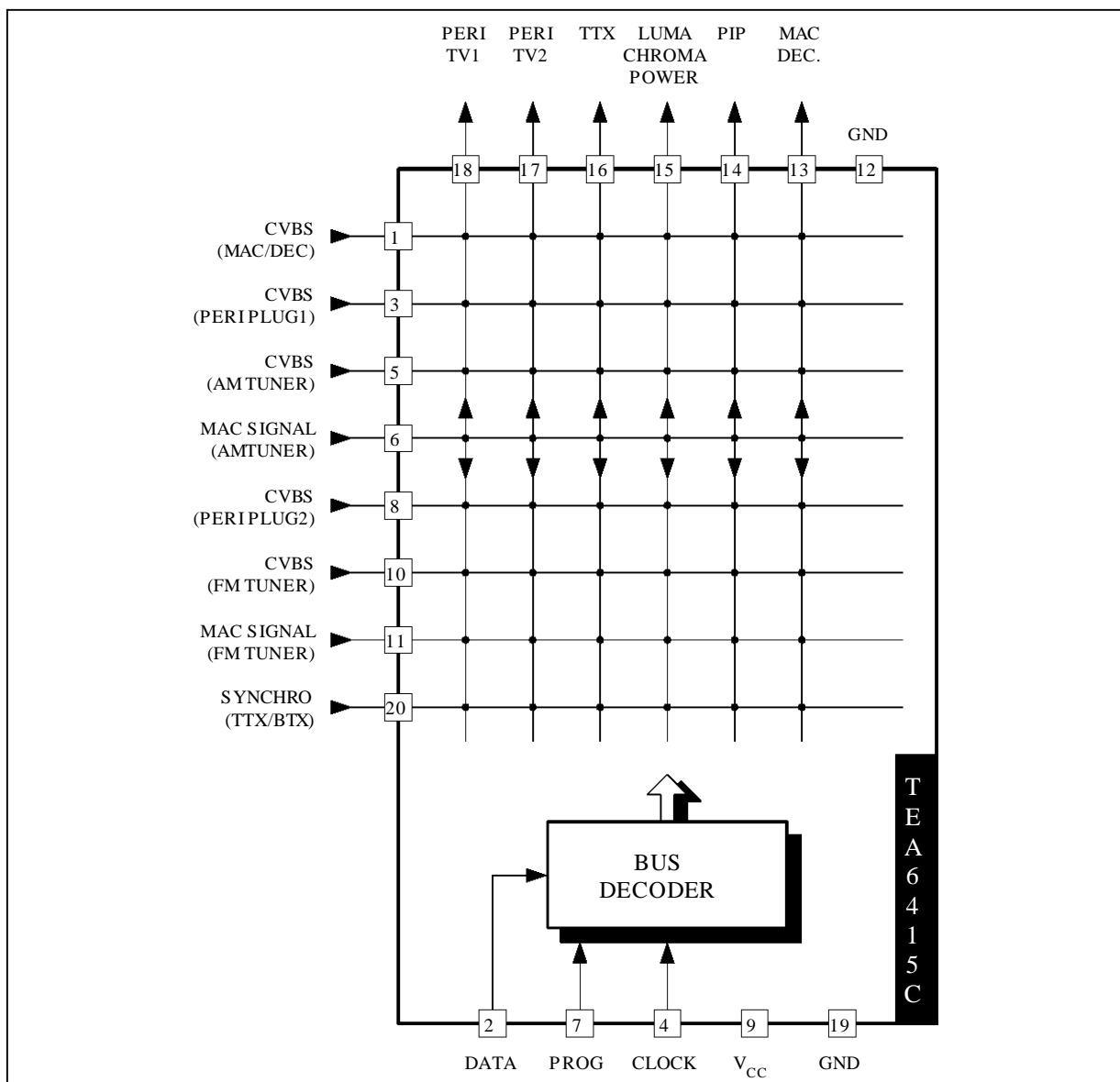

GENERAL DESCRIPTION

The main function of the IC is to switch 8 video input sources on 6 outputs.

Each output can be switched on only one of each input. On each input an alignment of the lowest level of the signal is made (bottom of synch. top for CVBS or black level for RGB signals).

Each nominal gain between any input and output is 6.5dB. For D2MAC or Chroma signal the alignment is switched off by forcing, with an external resistor bridge, 5 V_{DC} on the input. Each input can be used as a normal input or as a MAC or Chroma

input (with external resistor bridge). All the switching possibilities are changed through the BUS.

Driving 75Ω load needs an external transistor.

It is possible to have the same input connected to several outputs.

The starting configuration upon power on (power supply : 0 to 10V) is undetermined.

In this case, 6 words of 16 bits are necessary to determine one configuration. In other case, 1 word of 16 bits is necessary to determine one configuration.

1 FEATURES

- 5 V supply voltage
- Gain controlled wide-band Vision Intermediate Frequency (VIF) amplifier, AC-coupled
- Multistandard true synchronous demodulation with active carrier regeneration: very linear demodulation, good intermodulation figures, reduced harmonics, and excellent pulse response
- Gated phase detector for L and L-accent standard
- Fully integrated VIF Voltage Controlled Oscillator (VCO), alignment-free, frequencies switchable for all negative and positive modulated standards via I²C-bus
- Digital acquisition help, VIF frequencies of 33.4, 33.9, 38.0, 38.9, 45.75, and 58.75 MHz
- 4 MHz reference frequency input: signal from Phase-Locked Loop (PLL) tuning system or operating as crystal oscillator
- VIF Automatic Gain Control (AGC) detector for gain control, operating as peak sync detector for negative modulated signals and as a peak white detector for positive modulated signals
- External AGC setting via pin OP1
- Precise fully digital Automatic Frequency Control (AFC) detector with 4-bit digital-to-analog converter, AFC bits readable via I²C-bus
- TakeOver Point (TOP) adjustable via I²C-bus or alternatively with potentiometer
- Fully integrated sound carrier trap for 4.5, 5.5, 6.0, and 6.5 MHz, controlled by FM-PLL oscillator
- Sound IF (SIF) input for single reference Quasi Split Sound (QSS) mode, PLL controlled

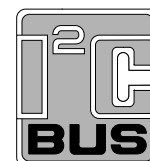

- SIF-AGC for gain controlled SIF amplifier, single reference QSS mixer able to operate in high performance single reference QSS mode and in intercarrier mode, switchable via I²C-bus
- AM demodulator without extra reference circuit
- Alignment-free selective FM-PLL demodulator with high linearity and low noise
- I²C-bus control for all functions
- I²C-bus transceiver with pin programmable Module Address (MAD)
- Four I²C-bus addresses via MAD.

2 GENERAL DESCRIPTION

The TDA9885 is an alignment-free multistandard (PAL and NTSC) vision and sound IF signal PLL demodulator for negative modulation only and FM processing.

The TDA9886 is an alignment-free multistandard (PAL, SECAM and NTSC) vision and sound IF signal PLL demodulator for positive and negative modulation, including sound AM and FM processing.

3 APPLICATIONS

- TV, VTR, PC and STB applications.

4 ORDERING INFORMATION

TYPE NUMBER	PACKAGE		
	NAME	DESCRIPTION	VERSION
TDA9885T/V3	SO24	plastic small outline package; 24 leads; body width 7.5 mm	SOT137-1
TDA9885TS/V3	SSOP24	plastic shrink small outline package; 24 leads; body width 5.3 mm	SOT340-1
TDA9885HN/V3	HVQFN32	plastic, heatsink very thin quad flat package; no leads; 32 terminals; body 5 × 5 × 0.85 mm	SOT617-1
TDA9886T/V3	SO24	plastic small outline package; 24 leads; body width 7.5 mm	SOT137-1
TDA9886TS/V3	SSOP24	plastic shrink small outline package; 24 leads; body width 5.3 mm	SOT340-1

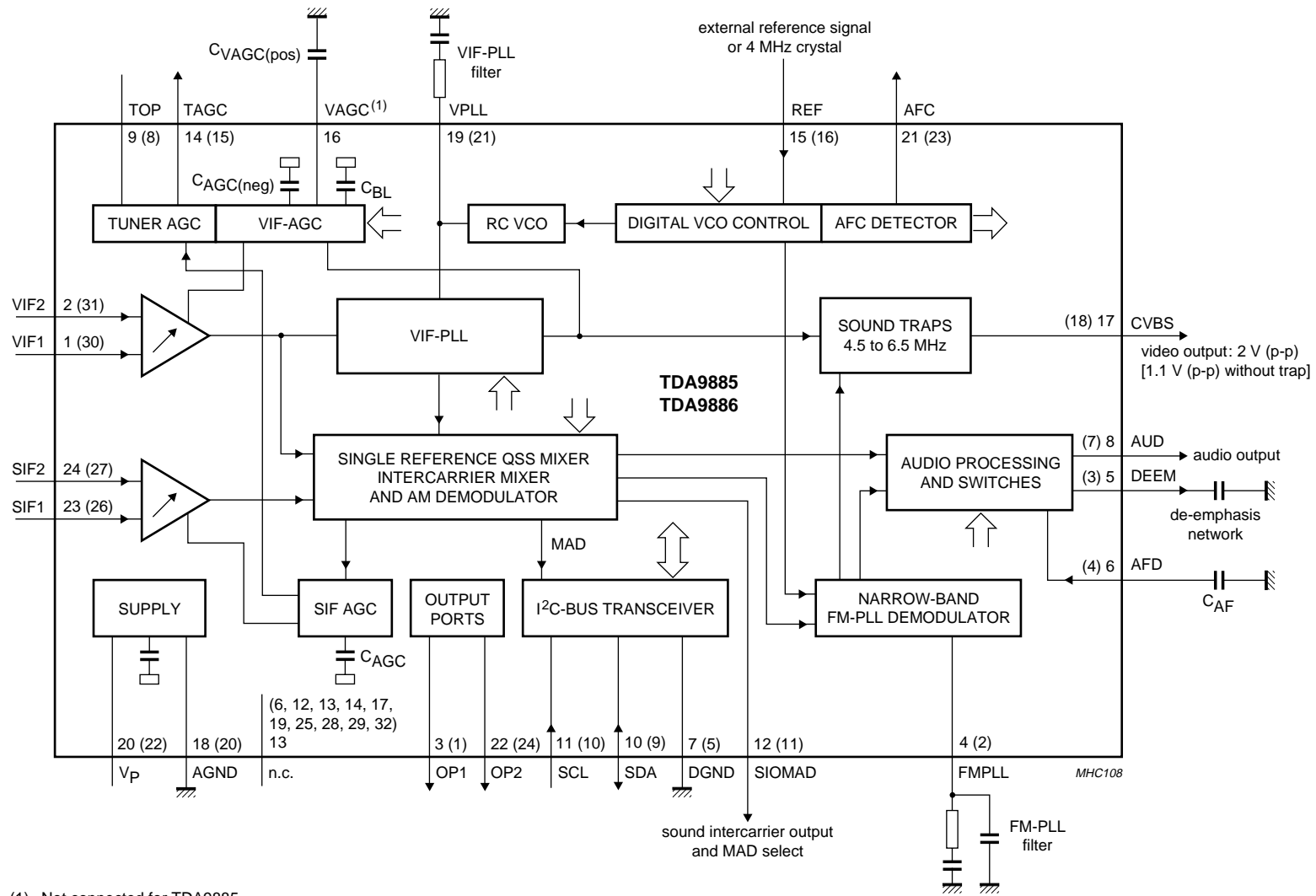

(1) Not connected for TDA9885.
Pin numbers for TDA9885HN in parenthesis.

Fig.1 Block diagram.

BUS-CONTROLLED AUDIO MATRIX

- 5 STEREO INPUTS
- 4 STEREO OUPUTS
- GAIN CONTROL 0/2/4/6dB/MUTE FOR EACH OUTPUT
- CASCADABLE (2 different addresses)
- SERIAL BUS CONTROLLED
- VERY LOW NOISE
- VERY LOW DISTORSION

DESCRIPTION

The TEA6420 switches 5 stereo audio inputs on 4 stereo outputs.

All the switching possibilities are changed through the I²C bus.

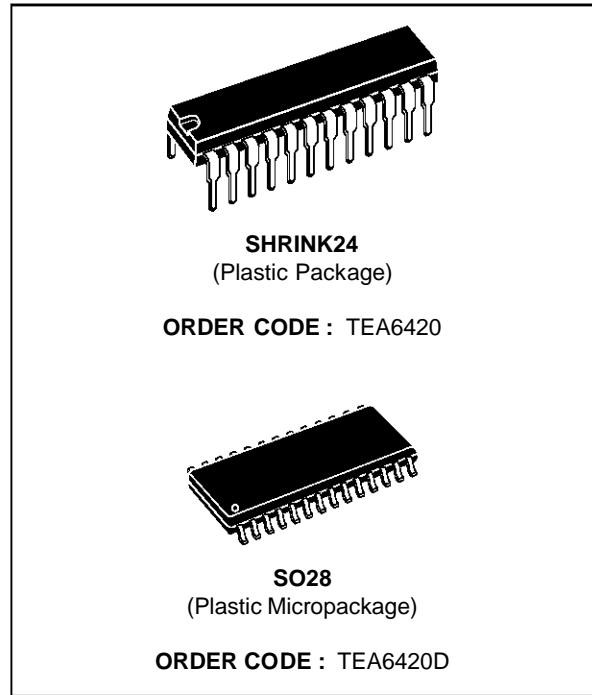

PIN CONNECTIONS

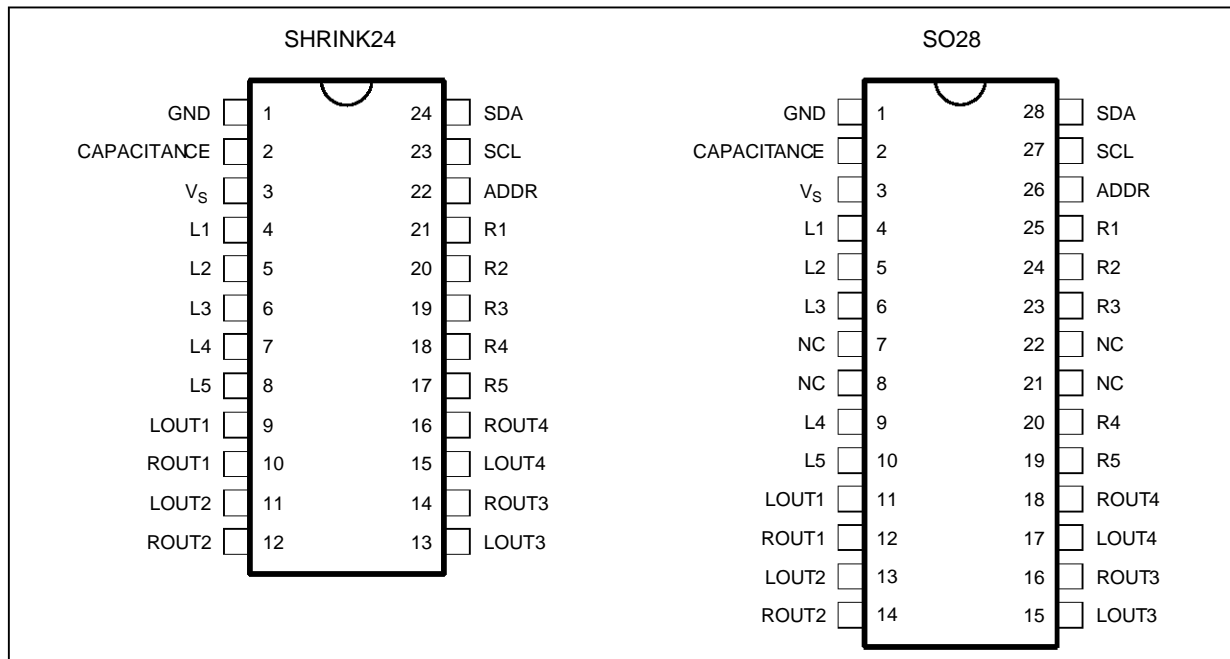

TEA6420

BLOCK DIAGRAM

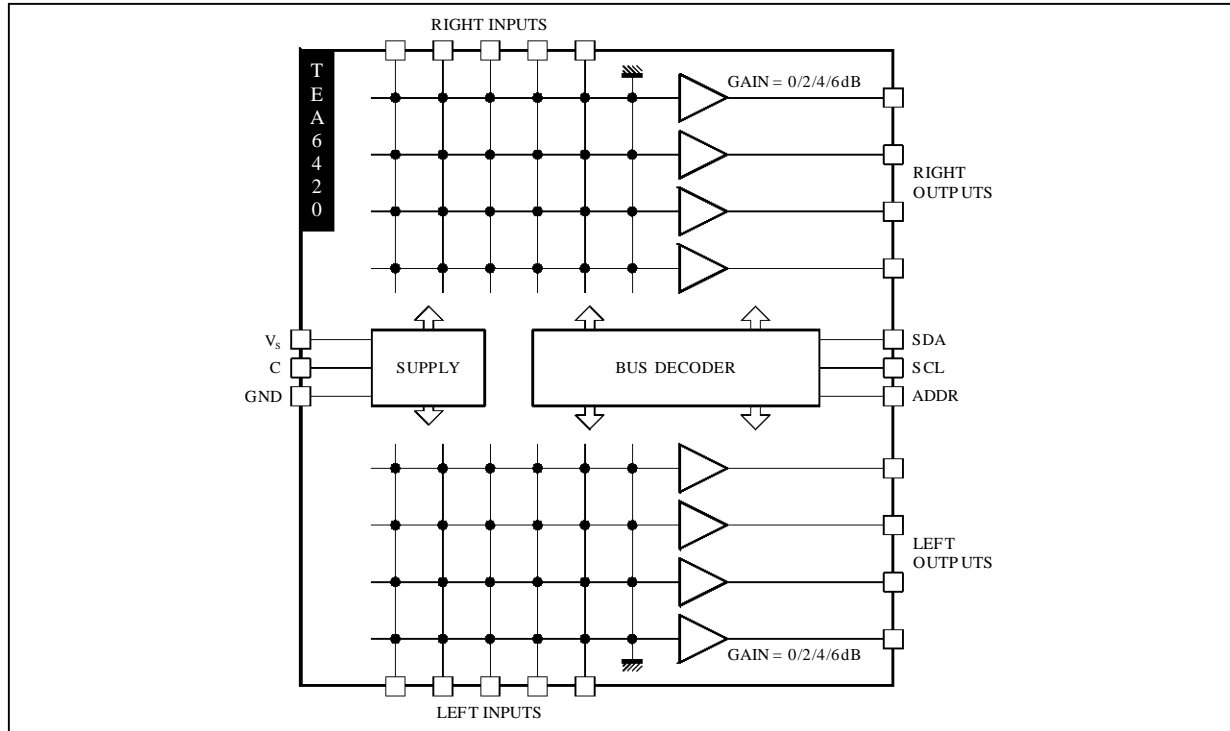

6420-03.EPS

ABSOLUTE MAXIMUM RATINGS

Symbol	Parameter	Value	Unit
V _{CC}	Supply Voltage	10.2	V
T _{oper}	Operating Ambient Temperature	0, + 70	°C
T _{stg}	Storage Temperature	- 20, + 150	°C

6420-01.TBL

THERMAL DATA

Symbol	Parameter	Value	Unit
R _{th(j-a)}	Junction Ambient Thermal Resistance	SHRINK24 SO28 75 75	°C/W

6420-02.TBL

ELECTRICAL CHARACTERISTICS

T_A = 25°C, V_S = 10V, R_L = 10kΩ, R_G = 600Ω, f = 1kHz (unless otherwise specified)

Symbol	Parameter	Test Conditions	Min.	Typ.	Max.	Unit
--------	-----------	-----------------	------	------	------	------

SUPPLY

V _S	Supply Voltage		8	9	10.2	V
I _S	Supply Current			5	8	mA
SVR	Ripple Rejection	V _{IN} = 500mV _{RMS} , BW = 20 - 20kHz	70	80		dB

MATRIX

V _{IN}	Input DC Level		4.5	5	5.5	V
R _I	Input Resistance		30	50	100	kΩ
C _S	Channel Separation	V _{IN} = 2V _{RMS} f = 1kHz	Gain = 0dB Gain = 6dB	80 70	90 82	dB dB

6420-03.TBL

PW1231

Product Specification



General

The PW1231 is a high-quality, digital video signal processor that incorporates Pixelworks' patented deinterlacing, scaling, and video enhancement algorithms. The PW1231 accepts industry-standard video formats and resolutions, and converts the input into any desired output format. The video algorithms are highly efficient, providing excellent quality video.

The PW1231 Video Signal Processor combines many functions into a single device, including memory controller, auto-configuration, and others. This high level of integration enables simple, flexible, cost-effective solutions featuring fewer required components.

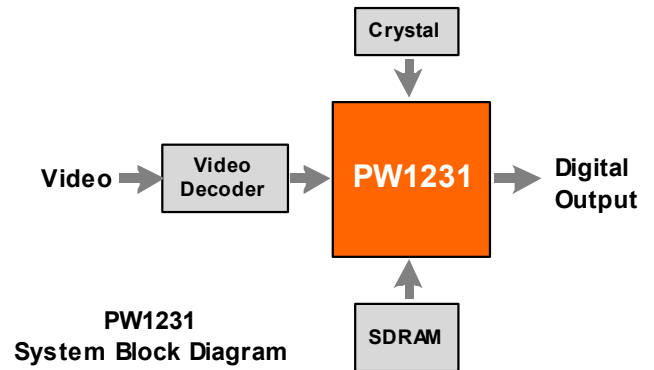

Features

- Built-In Memory Controller
- Motion-Adaptive Deinterlace Processor
- Intelligent Edge Deinterlacing
- Digital Color/Luminance Transient Improvement (DCTI/DLTI)
- Interlaced Video Input Options, including NTSC and PAL
- Independent horizontal and vertical scaling
- Copy Protection
- Two-Wire Serial Interface

Applications: For use with Digital Displays

- Flat-Panel (LCD, DLP) TVs
- Rear Projection TVs
- Plasma Displays
- LCD Multimedia Monitors
- Multimedia Projectors

Device	Application	Package
PW1231 PW1231-L	Up to XGA	160-pin PQF

NOTE: "L" denotes lead (Pb) free

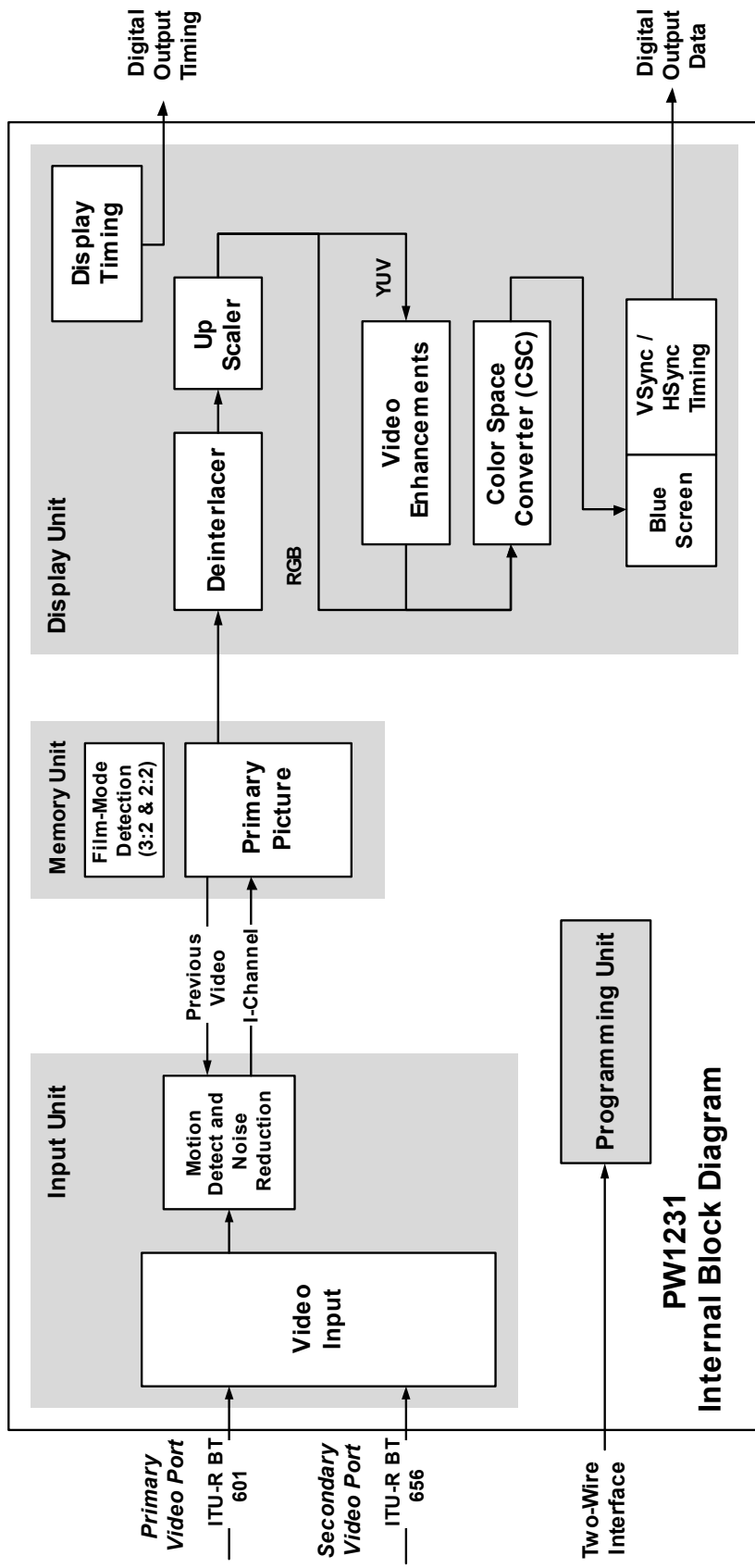

Figure 1-1 Internal Block Diagram

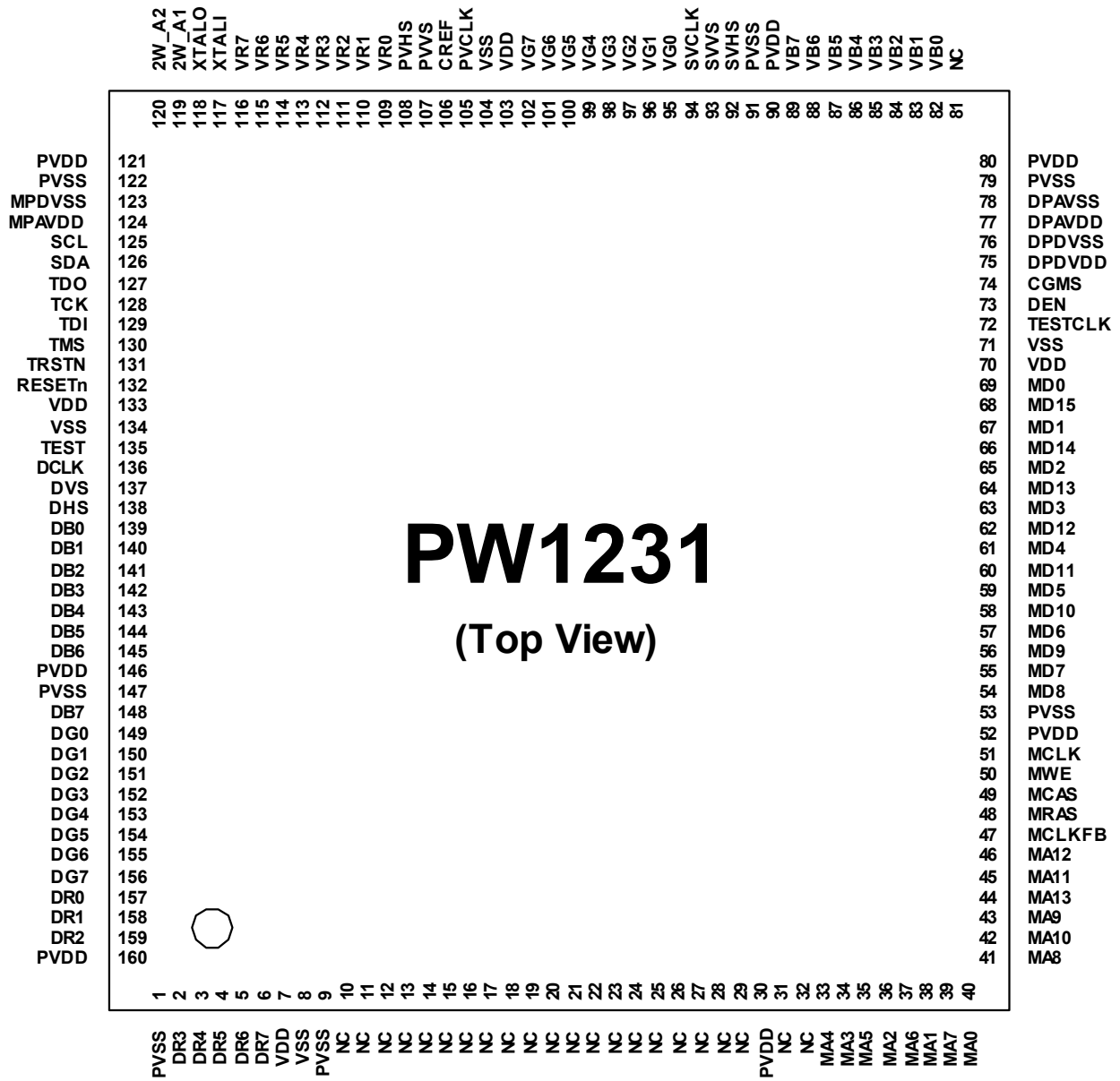

Figure 2-1 PW1231 Pin Layout

PW181

Product Specification



General Description

The PW181 ImageProcessor is a highly integrated “system-on-a-chip” that interfaces computer graphics and video inputs in virtually any format to a fixed-frequency flat panel display.

Computer and video images from NTSC/PAL to WUXGA at virtually any refresh rate can be resized to fit on a fixed-frequency target display device with any resolution up to WUXGA. Video data from 4:3 aspect ratio NTSC or PAL and 16:9 aspect ratio HDTV or SDTV is supported. Multi-region, nonlinear scaling allows these inputs to be resized optimally for the native resolution of the display.

Advanced scaling techniques are supported, such as format conversion using multiple programmable regions. Three independent image scalers coupled with frame locking circuitry and dual programmable color lookup tables create sharp images in multiple windows, without user intervention.

Embedded SDRAM frame buffers and memory controllers perform frame rate conversion and enhanced video processing completely on-chip. A separate memory is dedicated to storage of on-screen display images and CPU general purpose use.

Advanced video processing techniques are supported using the internal frame buffer, including motion adaptive, temporal deinterlacing with film mode detection. When used in combination with the new third-generation scaler, this advanced video processing technology delivers the highest quality video for advanced displays.

Both input ports support integrated DVI 1.0 content protection using standard DVI receivers.

A new advanced OSD Generator with more colors and larger sizes supports more demanding OSD applications, such as on-screen programming guides. When coupled with the new, faster, integrated microprocessor, this OSD Generator supports advanced OSD animation techniques.

Programmable features include the user interface, custom start-up screen, all automatic imaging features, and special screen effects.

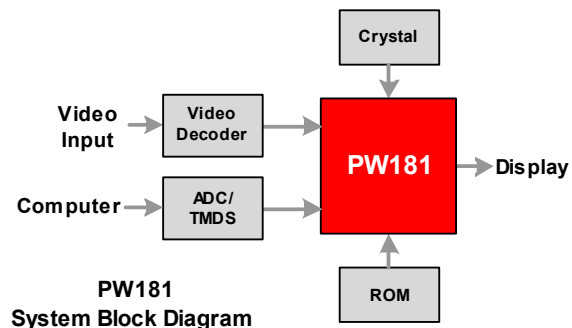

Features

- Third-generation, two-dimensional filtering techniques
- Third-generation, advanced scaling techniques
- Second-generation Automatic Image Optimization
- Frame rate conversion
- Video processing
- On-Screen Display (OSD)
- On-chip microprocessor
- JTAG debugger and boundary scan
- Picture-in-picture (PIP)
- Multi-region, non-linear scaling
- Hardware 2-wire serial bus support

Applications

- Multimedia Displays
- Plasma Displays
- Digital Television

Device	Application	Package
PW181-10V	Up to XGA Displays	352 PBGA
PW181-20V	Up to UXGA Displays	
PW181-30V	Up to WUXGA Display	

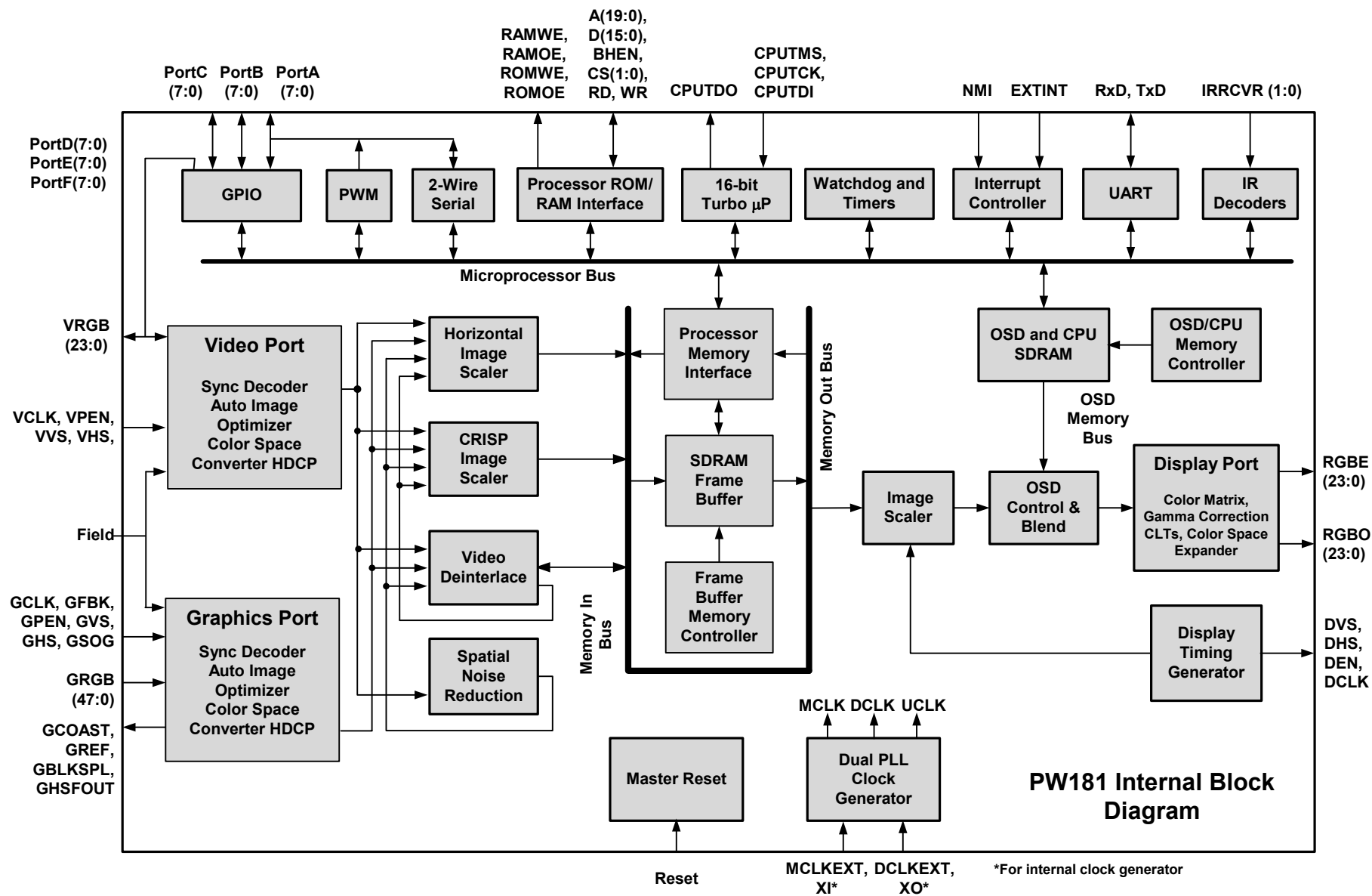

Figure 1-1 Internal Block Diagram

PART LIST

	Part Codes	Part Definition	Quantity	
BOARDS AND MODULES	031491	PLUG AC INLET TWO PHASE NOISE FILTER	1	
	R79110	L6B PDP CHASIS 42"	1	
	R82172	CU ASSY 42P6L43	1	
	R82175	SPEAKER BOARD COMPLETED L6B PDP 42"	1	
	R82185	SCART BOARD COMPLETED L6B PDP 42"	1	
	X47102	PDP 42" LG V6 PANEL VE PW SP.DAEGIL PSU	1	
	ZR1910	ADAPTOR SPS 180W 24/5 12/5 PFC 2PIN(LISH	1	
	ZR4187R	R/C L6B SASI REMOTE CONTROL JAECS SILVER	1	
	BRAND-BEKO/TEST 42P6B43 SIL CU	038980R	MAIN CABLE PC/MONITOR 2MT EUROWITH FERR	1
X24251F		FRONT COVER 42"PDP B43 WITH KEY.B.SIL.P.	1	
CU ASSY 42P6L43	010860R	TACT SW LONG STEN	1	
	303447R	LED 3MM RED-BLUE LIGITEK LSRFSBK2092	1	
	452521R-1	IR RECEIVER TSOP34838 SS1A	1	
	R82174	CU PN 42P6L43 (X24193-01)	1	
FRONT FRAME 42P6B43 SILVER(V6)	010690R	ROCKER SWITCH R19 DPST	1	
	R73028	MESH FILTER (E)M4213JW0345L S1(SK)V6	1	
	R79356	42" PDP L6B V6 AV BOARD BOX	1	
	R79357	42" PDP L6B V6 AV BD BOX BACK COV.BOT	1	
	R79362	42" PDP L6B LG V6 PW BOARD MONT.SH. IRON	1	
	R79363	42" PDP L6B LG V6 PW BD MONT.SH. IRON EA	1	
	X24204F	LENS IR/LED 42" PDP MODEL P	1	
	X24262F	"KNOB PRG UP/DOWN SIL. P.ED 42""PDP MOD.	1	
	X24330	FRONT COV.ALU.SUP.RIG/LEFT LG-SDI+EMI+CU	1	
	X24331	FRONT COVER ALU.SUPP.BOTTOM LG+EMI+CUSH	1	
	X24332	FRONT COVER ALU.SUPP.TOP LG+EMI+CUSHION	1	
	X24355	42" PDP BACK COVER B43/B41 MODEL	1	
	X24359	42" PDPLG PANEK BRIDGE RIGHT	1	
	X24360	42" PDPLG PANEK BRIDGE LEFT	1	
	X24380	42" PDP ANGLE IRON	1	
	X24805	STROPOR TOP LEFT-RIGHT 42 PDP PLS	1	
	X24806	STROPOR BOT.LEFT-RIGHT 42 PDP PLS	1	
	X41359	42" PDP PANEL CONNECTION PART LG V6	1	
	X52372	42" PDP BACK COVER COMP.SCREW(M8)	1	
	L6B CHASSIS	031194	CONN.HOUS.4P 2317-4S JST B 4B-XH-A WHITE	1
		031245	CONN.HOUS.2P 2317-2S JST B 2B-XH-A WHITE	1
		031251	SCART SOCKET 14.1	2
		031299	CONN.HOUS.10P 2317-10S JST4B-XH-A BEYAZ	1
031358		CONN. VGA B10B	1	
031423R		HEADPHONE JACK YKB21-5103	1	
031476		CONN.HOUSING.12P 2MM 89400-1210 MOLEX	1	
031508R		CONN. RF IEC TO RCA	1	
031658		CONN.HOUSING.10P 2MMM 89400-1010 MOLEX	1	
031769R		CONN.HOUS.4P 2317-4S JST B 4B-XH-A RED	1	
031795		KONN.S-VHS	1	
032945R		CONN.MALE 2*15 30LU MOLEX 53505-3090	1	
053352R		COIL- CHOKE 10UH R0814 14.1	4	
053500R		COIL 10UH K AXIAL LAL04	2	
053725R		COIL-CHIP 10UH %20/0805	18	
053782R		COIL 47UH K LAL04	2	
053881R		COIL 1UH K LAL04 AXIAL	4	
053901R		COIL SHOKE TOROID 100UH M 0.07R	2	
054290		FUSE 5.0A 250V ROUND	2	
054290R		FUSE 5.0A 250V ROUND	2	
055622R		FERRIT BEAD-CHIP 100MHZ 4A	2	
055628		FERRIT ARRAY 1K BK32164M102-T/1206 T&R	1	
055628R		FERRIT ARRAY 1K BK32164M102-T/1206 T&R	1	
056010R		SAW FILTER OFW K9656M	2	
056013R		CRYSTAL 4 MHZ HC49-U	2	
056119		CRYSTAL 14.31818MHz CL=18PF30/30PPMHC49U	1	
056119R		CRYSTAL 14.31818 MHz / HC49U	1	
056121R		CRYSTAL 10 MHz / HC49U 20PF 30PPM	1	
056708R		SAW FILTER OFW K3958M	2	
056753R		CRYSTALL 24.576MHZ 20PF 30PPM	2	
056952R		CRYSTAL 18.432MHZ +-30PPM	1	
102397R		CFR 3.9K J 1/4W /6 52MM	1	
L6B CHASSIS		111395R	RMO 390R J 1W	2

	Part Codes	Part Definition	Quantity
	170102R	RC-CHIP 10R J 1/8W /1206	2
	170112R	RC-CHIP 2K J 1/16W /0603 TAPE	1
	170154R	RC-CHIP 150R J 1/16W /0603 TAPE	3
	170181R	RC-CHIP 18R J 1/16W /0603	8
	170474R	RC-CHIP 47R J 1/16W /0603 TAPE	12
	170560R	RC-CHIP 56R J 1/16W /0603 TAPE	8
	170686R	RC-CHIP 68R J 1/10W /0603	3
	170751R	RC-CHIP 75R J 1/10W/0603	15
	171108R	RC-CHIP 100R J 1/10W /0603	51
	171224R	RC-CHIP 220R J 1/16W/0603 TAPE	4
	171275R	RC-CHIP 270R F 1/10W /0603	1
	171336R	RC-CHIP 330R J 1/16W /0603 TAPE	3
	171472R	RC-CHIP 470R J 1/16W /0603 TAPE	3
	171562	RC-CHIP 560R J 1/16W/0603 TAPE	1
	171562R	RC-CHIP 560R J 1/16W/0603 TAPE	1
	171683R	RC-CHIP 680R J 1/16W /0603	7
	171824R	RC-CHIP 820R J 1/16W /0603 TAPE	1
	172104R	RC-CHIP 1K J 1/16W /0603	2
	172111R	RC-CHIP 1K J 1/10W /0603	32
	172112	RC-CHIP 1K 1% 1/10W /0603	2
	172112R	RC-CHIP 1K 1% 1/10W /0603	2
	172228R	RC-CHIP 2.2K J 1/10W /0603	5
	172336R	RC-CHIP 3.3K J 1/16W /0603	14
	172393R	RC-CHIP 3.9K J 1/16W/0603 TAPE	1
	172473R	RC-CHIP 4.7K J 1/10W /0603	37
	172567R	RC-CHIP 5.6K J 1/16W /0603 TAPE	2
	172686	RC-CHIP 6.8K J 1/16W /0603	2
	172686R	RC-CHIP 6.8K J 1/16W /0603	2
	172824R	RC-CHIP 8.2K J 1/16W /0603 TAPE	1
	173100R	RC-CHIP 10K J 1/10W /0603	23
	173108R	RC-CHIP 10K J 1/16W /0603	2
	173124R	RC-CHIP 12K J 1/16W /0603 TAPE	4
	173228R	RC-CHIP 22K J 1/10W /0603	6
	173229	RC-CHIP 22K J 1/16W /0603	2
	173229R	RC-CHIP 22K J 1/16W /0603	2
	173332R	RC-CHIP 33K J 1/16W /0603 TAPE	2
	173563R	RC-CHIP 56K J 1/16W /0603	2
	174152R	RC-CHIP 150K J 1/16W /0603 TAPE	2
	175105R	RC-CHIP 1M J 1/16W/0603 T&R	2
	175221R	RC-CHIP 2.2M J 1/16W /0603	1
	179005R	RC-CHIP 0R /0603 1.6*0.8 TAPE	75
	179475R	RC-CHIP 4.7R J 1/16W/0603	2
	190471R	R-ARRAY-CHIP 47R*4/YC16	25
	250332	EC 3.3UF 50V 11*5 R:5	1
	250332R	EC 3.3UF 50V 11*5 R:5	1
	250333R	EC 3.3UF 16V 11*5 R:5	1
	251112R	EC 10UF 50V RS 11*5 TAPING R=5MM	9
	251222R	EC 22UF 50V RS 11*6.3 TAPING	8
	251475R	EC 47UF 63V 11*6.3 R:5	13
	252105R	EC 100UF 50V 12*8 R:5	6
	252112R	EC 100UF 16V 11*6 R:5	28
	252241R	EC 220UF 35V WL 16*8 LESR/HRPL	2
	253109	EC 1000UF 35V 30*10 R:5	4
	273121R	C-PEM 10NF J 100V R:5	5
	274227	C-PEM 220NF J 50V R:5	4
	274227R	C-PEM 220NF J 50V R:5	4
	274474R	C-PEM 470NF J 63V R:5	6
	280107R	TC-CHIP 1UF 25V /A3216	2
	280225R	TC-CHIP 2.2UF 10V /A3216	2
	290019R	CC-CHIP 1.8PF C 50V/0603 NPO	2
	290107R	CC-CHIP 10PF J 50V /0603 NPO TAPE	5
	290122R	CC-CHIP 12PF J 50V /0603	3
	290186R	CC-CHIP 18PF J 50V /0603 NPO	5
	290223R	CC-CHIP 22PF J 50V /0603 NPO TAPE	2
	290335R	CC-CHIP 33PF J 50V /0603 NPO TAPE	1
	290390R	CC-CHIP 39PF J 50V /0805 NPO	4
	290391R	CC-CHIP 39PF J 50V /0603 NPO	6
L6B CHASSIS	290475R	CC-CHIP 47PF J 50V /0603 NPO TAPE	3
	291104R	CC-CHIP 100PF J 50V /0603 NPO	4

	Part Codes	Part Definition	Quantity
	291155R	CC-CHIP 150PF J 50V /0603 TAPE	10
	291393	CC-CHIP 390PF J 50V /0603 NPO TAPE	2
	291393R	CC-CHIP 390PF J 50V /0603 NPO TAPE	2
	292114R	CC-CHIP 1NF K 50V /0603 X7R	51
	292115R	CC-CHIP 1NF J 50V /0603	4
	292153R	CC-CHIP 1.5NF K 50V /0603 X7R TAPE	2
	292392R	CC-CHIP 3.9NF K 50V /0603 X7R	1
	292475R	CC-CHIP 4.7NF K 50V /0603 X7R	2
	293391R	CC-CHIP 39NF K 50V /0603 X7R	1
	293478R	CC-CHIP 47NF K 25V /0603 X7R TAPE	36
	294122R	CC-CHIP 100NF K 50V /0603 X7R	205
	294234R	CC-CHIP 220NF K 16V /0603 X7R	27
	294476R	CC-CHIP 470NF K 16V /0805 X7R	6
	302318	DIODE Z. BZX55C33 52MM	1
	302318R	DIODE Z. BZX55C33 52MM	1
	302948R	DIODE 1N4007	1
	303180-AS	DIODE 1N5820 SCHOTTKY FERRIT	2
	303195R	DIODE 4148 MELF SOD-80C	8
	303197	DIODE BAV70	2
	303197R	DIODE BAV70	2
	303223R	DIODE-CHIP BA682 SOD80	2
	303420	DIODE-CHIP BA591 SOT323 TAPE	2
	303818R	DIODE-CHIP BAV99LT1 SOT23 T&R	9
	303864R	DIODE Z.TZMC5V6-5.6V SOD80C	2
	303867R	DIODE-CHIP SL23 DO214AA	4
	401141R	TRN-CHIP BC848BLT1G SOT23	25
	401372R	TRN FDS9933A	1
	451569R	IC-CHIP TDA9886T/V3 118(SO24) T&R	2
	452863R	IC MT48LC4M16A2P-7E SDRAM 54PIN TSOP	1
	453007	IC LM2596S-5.0	1
	453095R	IC-CHIP NCP1117DTARK G (DPAK) T&R TO252	1
	453124R	IC-CHIP NCP1117DT33RK G TO-252 PACKAGE	4
	453195R	IC PI5V330WEX SOIC(W)	1
	453233	IC-CHIP AM29LV160DB-90EC (TRAY)TSOP48	1
	453261	IC-CHIP 24LC21A-I/SN-CMOS18K/2.5V SE.T&R	2
	453262R	IC-CHIP AD9887AKSZ-100 DUAL IN.FACE TRAY	1
	453263R	IC-CHIP AT24C64AN-10SU-2.7 SO8 T&R	1
	453271R	IC-CHIP TEA6415CDT -VIDEO-MAT-SW.T&R	1
	453294R	IC-CHIP LM2576D2TR4-005V 3A TO263 STPT&R	1
	453310R	IC-CHIP SAA7118E/V1/M5 BGA156 T&R	2
	453346R	IC-CHIP PW1231A L	1
	453347R	IC-CHIP PW181A-10V L BGA352	1
	453349R	IC-CHIP TLC7733 /SO8	1
	453350R	IC-CHIP PCF8591 /SO16	1
	453351R	IC-CHIP TEA6420DT T&R	1
	453352R	IC-CHIP MSP3410-MQFP64	1
	453428R	IC-CHIP LM317MDTRK G TO-252 T&R	1
	453494R	IC-CHIP TRIPATH TA2024 STEREO CLAS-D T&R	1
	453921R	IC-CHIP DS90C385A MTD56	1
	R84501R	CABLE L=65MM GREEN AWG28	1
	Y11136R	TUNER HOR.PHILLIPS UV1316/A I H-4	1
	Y11501R	CABLE RF TUNER L=50MM L5B PH.TUN.	1
	Y51136RPH1	TUNER PH UV1316T/SIGH-3 SPL ASIMTRK YAT	1
	Y51501R	CABLE PIP TUNER L=230MM	1
L6B PDP 42" CABLE V6 PANEL	055145R	FERRIT CORE Z=276R (100MHZ) STEWARD	1
	R79525R	KONN.CAB.4PL=150MM 250G2-H04 FERRIT	1
	R82523-AS	CABLE L6B PDP 42" POW.SUP.2 PIN L=530MM	1
	R82527-AS	CABLE WITH.TERM.L=500MM YEL-GR AWG22	1
	R82535-AS	CABLE WITH.KONN.2P L=480+340MM FERRIT	1
	X56523-AS	CABLE WITH TERM SW-LINE FILTRE L=110MM	1
	X56525-AS	CABLE WITH.KONN.2P L=60MM	1
	X56525R	CABLE WITH.KONN.2P L=60MM	1

Note:This list tentative and also cabinet and other cosmetics parts can be changed with your model,

For such a issue please contact Beko Spare part department by giving your model .For panel modules codes, see in the panel service manual.

FREQUENCY TABLE (MHz)

Channel	Number	BG	I	DK	L/L'
CH	1		49.75	49.75	47.75
CH	2	48.25	59.25	59.25	55.75
CH	3	55.25	77.25	77.25	60.50
CH	4	62.25	85.25	85.25	63.75
CH	5	175.25	93.25	93.25	176.00
CH	6	182.25	175.25	175.25	184.00
CH	7	189.25	183.25	183.25	192.00
CH	8	196.25	191.25	191.25	200.00
CH	9	203.25	199.25	199.25	208.00
CH	10	210.25	207.25	207.25	216.00
CH	11	217.25	215.25	215.25	189.25
CH	12	224.25	223.25	223.25	182.25
CH	13	53.75	45.75		196.25
CH	14	62.25	53.75		210.25
CH	15	82.25	61.75		
CH	16	175.25	69.75		
CH	17	183.25	95.25		
CH	18	192.25			
CH	19	201.25			
CH	20	210.25			
CH	21	471.25	471.25	471.25	471.25
CH	22	479.25	479.25	479.25	479.25
CH	23	487.25	487.25	487.25	487.25
CH	24	495.25	495.25	495.25	495.25
CH	25	503.25	503.25	503.25	503.25
CH	26	511.25	511.25	511.25	511.25
CH	27	519.25	519.25	519.25	519.25
CH	28	527.25	527.25	527.25	527.25
CH	29	535.25	535.25	535.25	535.25
CH	30	543.25	543.25	543.25	543.25
CH	31	551.25	551.25	551.25	551.25
CH	32	559.25	559.25	559.25	559.25
CH	33	567.25	567.25	567.25	567.25
CH	34	575.25	575.25	575.25	575.25
CH	35	583.25	583.25	583.25	583.25
CH	36	591.25	591.25	591.25	591.25
CH	37	599.25	599.25	599.25	599.25
CH	38	607.25	607.25	607.25	607.25
CH	39	615.25	615.25	615.25	615.25
CH	40	623.25	623.25	623.25	623.25
CH	41	631.25	631.25	631.25	631.25
CH	42	639.25	639.25	639.25	639.25
CH	43	647.25	647.25	647.25	647.25
CH	44	655.25	655.25	655.25	655.25

Channel	Number	BG	I	DK	L/L'
CH	45	663.25	663.25	663.25	663.25
CH	46	671.25	671.25	671.25	671.25
CH	47	679.25	679.25	679.25	679.25
CH	48	687.25	687.25	687.25	687.25
CH	49	695.25	695.25	695.25	695.25
CH	50	703.25	703.25	703.25	703.25
CH	51	711.25	711.25	711.25	711.25
CH	52	719.25	719.25	719.25	719.25
CH	53	727.25	727.25	727.25	727.25
CH	54	735.25	735.25	735.25	735.25
CH	55	743.25	743.25	743.25	743.25
CH	56	751.25	751.25	751.25	751.25
CH	57	759.25	759.25	759.25	759.25
CH	58	767.25	767.25	767.25	767.25
CH	59	775.25	775.25	775.25	775.25
CH	60	783.25	783.25	783.25	783.25
CH	61	791.25	791.25	791.25	791.25
CH	62	799.25	799.25	799.25	799.25
CH	63	807.25	807.25	807.25	807.25
CH	64	815.25	815.25	815.25	815.25
CH	65	823.25	823.25	823.25	823.25
CH	66	831.25	831.25	831.25	831.25
CH	67	839.25	839.25	839.25	839.25
CH	68	847.25	847.25	847.25	847.25
CH	69	855.25	855.25	855.25	855.25
CH	70		863,25		863.25
CH	71		871,25		
CH	72		879,25		
CH	73		887,25		160.00
CH	74	69.25			172.00
CH	75	76.25			220.00
CH	76	83.25			232.00
CH	77	90.25			244.00
CH	78	97.25			256.00
CH	79	59.25			268.00
CH	80	93.25			280.00
S	1	105.25	103.25	103.25	116.75
S	2	112.25	111.25	111.25	128.75
S	3	119.25	119.25	119.25	140.75
S	4	126.25	127.25	127.25	152.75
S	5	133.25	135.25	135.25	164.75
S	6	140.25	143.25	143.25	176.75
S	7	147.25	151.25	151.25	188.75
S	8	154.25	159.25	159.25	200.75
S	9	161.25	167.25	167.25	212.75
S	10	168.25	231.25	231.25	224.75
S	11	231.25	239.25	239.25	236.75
S	12	238.25	247.25	247.25	248.75
S	13	245.25	255.25	255.25	260.75
S	14	252.25	263.25	263.25	272.75

Channel	Number	BG	I	DK	L/L'
S	15	259.25	271.25	271.25	284.75
S	16	266.25	279.25	279.25	296.75
S	17	273.25	287.25	287.25	55.75
S	18	280.25	295.25	295.25	60.50
S	19	287.25	303.25	303.25	63.75
S	20	294.25			
S	21	303.25			303.25
S	22	311.25	311.25	311.25	311.25
S	23	319.25	319.25	319.25	319.25
S	24	327.25	327.25	327.25	327.25
S	25	335.25	335.25	335.25	335.25
S	26	343.25	343.25	343.25	343.25
S	27	351.25	351.25	351.25	351.25
S	28	359.25	359.25	359.25	359.25
S	29	367.25	367.25	367.25	367.25
S	30	375.25	375.25	375.25	375.25
S	31	383.25	383.25	383.25	383.25
S	32	391.25	391.25	391.25	391.25
S	33	399.25	399.25	399.25	399.25
S	34	407.25	407.25	407.25	407.25
S	35	415.25	415.25	415.25	415.25
S	36	423.25	423.25	423.25	423.25
S	37	431.25	431.25	431.25	431.25
S	38	439.25	439.25	439.25	439.25
S	39	447.25	447.25	447.25	447.25
S	40	455.25	455.25	455.25	455.25
S	41	463.25	463.25	463.25	463.25

PDP MODULE

SERVICE MANUAL

MODEL : PDP42V6####

CAUTION

1. BEFORE SERVICING THE PDP MODULE,
READ THE SAFETY PRECAUTIONS IN THIS MANUAL.
2. WHEN REPLACEMENT PARTS ARE REQUIRED, BE SURE TO USE
REPLACEMENT PARTS SPECIFIED BY THE MANUFACTURER..

SAFETY PRECAUTIONS

PDP Module is a display device to be divided into a Panel part and a Drive part. The Panel part consists of Electrodes, Phosphor, various dielectrics and gas, and the Drive part includes electronic circuitry and PCB. When using/handling this PDP Module, pay attention to the below warning and cautions.

Warning?

Indicates a hazard that may lead to death or injury if the warning is ignored and the product is handled incorrectly.

Caution?

Indicates a hazard that can lead to injury or damage to property if the caution is ignored and the product is handled incorrectly.

. WARNING

- (1) Do not supply a voltage higher than that specified to this product. This may damage the product and may cause a fire.
- (2) Do not use this product in locations where the humidity is extremely high, where it may be splashed with water, or where flammable materials surround it. Do not install or use the product in a location that does not satisfy the specified environmental conditions. This may damage the product and may cause a fire.
- (3) If a foreign substance (such as water, metal, or liquid) gets inside the product, immediately turn off the power. Continuing to use the product, it may cause fire or electric shock.
- (4) If the product emits smoke, and abnormal smell, or makes an abnormal sound, immediately turn off the power. Continuing to use the product, it may cause fire or electric shock.
- (5) Do not disconnect or connect the connector while power to the product is on. It takes some time for the voltage to drop to a sufficiently low level after the power has been turned off. Confirm that the voltage has dropped to a safe level before disconnecting or connecting the connector.
- (6) Do not pull out or insert the power cable from/to an outlet with wet hands. It may cause electric shock.
- (7) Do not damage or modify the power cable. It may cause fire or electric shock.

- (8) If the power cable is damaged, or if the connector is loose, do not use the product: otherwise, this can lead to fire or electric shock.
- (9) If the power connector or the connector of the power cable becomes dirty or dusty, wipe it with a dry cloth. Otherwise, this can lead to fire.
- (10) PDP Module uses a high voltage (Max.450V dc). Keep the cautions concerning electric shock and do not touch the Device circuitry when handling the PDP Unit. And because the capacitor of the Device circuitry may remain charged at the moment of Power OFF, standing by for 1 minute is required in order to touch the Device circuitry.

. CAUTIONS

- (1) Do not place this product in a location that is subject to heavy vibration, or on an unstable surface such as an inclined surface. The product may fall off or fall over, causing injuries.
- (2) Before disconnecting cable from the product, be sure to turn off the power. Be sure to hold the connector when disconnecting cables. Pulling a cable with excessive force may cause the core of the cable to be exposed or break the cable, and this can lead to fire or electric shock.
- (3) This product should be moved by two or more persons. If one person attempts to carry this product alone, he/she may be injured.
- (4) This product contains glass. The glass may break, causing injuries, if shock, vibration, heat, or distortion is applied to the product.
- (5) The temperature of the glass of the display may rise to 80°C or more depending on the conditions of use. If you touch the glass inadvertently, you may be burned.
- (6) If glass surface of the display breaks or is scratched, do not touch the broken pieces or the scratches with bare hands. You may be injured.
- (7) PDP Module requires to be handled with care not to be touched with metal or hard materials, and must not be stressed by heat or mechanical impact.
- (8) There are some exposed components on the rear panel of this product. Touching these components may cause an electric shock.
- (9) When moving the product, be sure to turn off the power and disconnect all the cables. While moving the product, watch your step. The product may be dropped or all, leading to injuries of electric shock.

- (10) In order to protect static electricity due to C-MOS circuitry of the Drive part, wear a wrist band to protect static electricity when handling.
- (11) If cleaning the Panel, wipe it with a soft cloth moistened with water or a neutral detergent and squeezed, being careful not to touch the connector part of the Panel. And don't use chemical materials like thinner or benzene.
- (12) If this product is used as a display board to display a static image, "image sticking" occurs. This means that the luminance of areas of the display that remain lit for a long time drops compared with luminance of areas that are lit for a shorter time, causing uneven luminance across the display. The degree to which this occurs is in proportion to the luminance at which the display is used. To prevent this phenomenon, therefore, avoid static images as much as possible and design your system so that it is used at a low luminance, by reducing signal level difference between bright area and less bright area through signal processing.
- (13) Because PDP Module emits heat from the Glass Panel part and the Drive circuitry, the environmental temperature must not be over 40°C.
The temperature of the Glass Panel part is especially high owing to heat from internal Drive circuitry. And because the PDP Module is driven by high voltage, it must avoid conductive materials.
- (14) If inserting components or circuit board in order to repair, be sure to fix a lead line to the connector before soldering.
- (15) If inserting high-power resistor(metal-oxide film resistor or metal film resistor) in order to repair, insert it as 10mm away as from a board.
- (16) During repairs, high voltage or high temperature components must be put away from a lead line.
- (17) This is a Cold Chassis but you had better use a cold transformer for safety during repairs. If repairing electricity source part, you must use the cold transformer.
- (18) Do not place an object on the glass surface of the display. The glass may break or be scratched.
- (19) This product may be damaged if it is subject to excessive stresses (such as excessive voltage, current, or temperature). The absolute maximum ratings specify the limits of these stresses.
- (20) The recommended operating conditions are conditions in which the normal operation of this product is guaranteed. All the rated values of the electrical specifications are guaranteed within these conditions.
Always use the product within the range of the recommended operating conditions. Otherwise, the reliability of the product may be degraded.
- (21) This product has a glass display surface. Design your system so that excessive shock and load are not applied to the glass. Exercise care that the vent at the corner of the glass panel is not damaged.
If the glass panel or vent is damaged, the product is inoperable.
- (22) Do not cover or wrap the product with a cloth or other covering while power is supplied to the product.
- (23) Before turning on power to the product, check the wiring of the product and confirm that the supply voltage is within the rated voltage range. If the wiring is wrong or if a voltage outside the rated range is applied, the product may malfunction or be damaged.
- (24) Do not store this product in a location where temperature and humidity are high. This may cause the product to malfunction. Because this product uses a discharge phenomenon, it may take time to light (operation may be delayed) when the product is used after it has been stored for a long time. In this case, it is recommended to light all cells for about 2 hours (aging).
- (25) This product is made from various materials such as glass, metal, and plastic. When discarding it, be sure to contact a professional waste disposal operator.
- (26) If faults occur due to arbitrary modification or disassembly, LG Electronics is not responsible for function, quality or other items.
- (27) Use of the product with a combination of parameters, conditions, or logic not specified in the specifications of this product is not guaranteed. If intending to use the product in such a way, be sure to consult LGE in advance.
- (28) Within the warranty period, general faults that occur due to defects in components such as ICs will be rectified by LGE without charge. However, IMAGE STICKING due to misapplying the above (12) provision is not included in the warranty. Repairs due to the other faults may be charged for depending on responsibility for the faults.

[PDP42V6#### Module]

CONTENTS

⅃ . Formation and Specification of Module

⅃-. Adjustment

⅃†. Trouble Shooting

1. Checking for No Picture

2. Hitch Diagnosis Following Display Condition

2-1. 4/7 or 3/7 of the screen doesn't be shown

2-2. Screen doesn't be shown as Data COF

2-3. It is generated unusual pattern of Data COF IC unit

2-4. Regular Stripe is generated about the quantity of one Data COF IC or more

2-5. Screen doesn't be shown at all as scan COF

2-6. Regular stripe is generated at regular interval on the whole screen

2-7. Data copy is generated to stripe direction

2-8. One or more stripe is generated on the screen

2-9. One or more horizontal line is generated on screen

2-10. Lightness of screen is wholly darken though there is input-signal-pattern

2-11. Different color is shown partially during full-white-screen or electric discharge is generated during full-black-screen

2-12. Full-white pattern it happened that the lightness of middle is darken while full-white pattern

2-13. Some lightness of some color doesn't not generated well

3. Checking for component damage

3-1. Y IPM(IC 12) or Z IPM(IC 4) damage

3-2. FET Ass'y(Y B/D: HS1) damage

3-3. SCAN IC(Y drv B/D: IC1~8) damage

3-4. COF damage

3-5. Crystal(CTRL B/D: X1) damage

⅃‡. Block Diagram

⅃-. Records of Revision for Boards, components and ROM DATA

* Annexing : Schematic Diagram

㉞ . Formation and Specification of Module

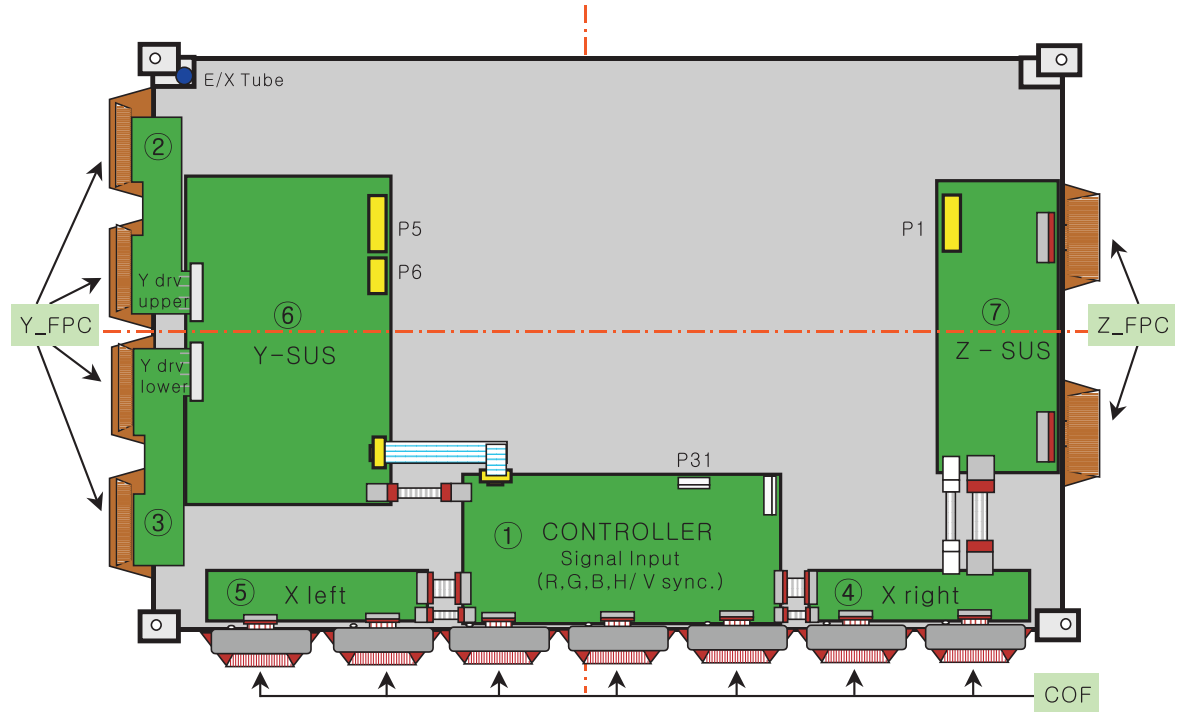

External Cable Connection

NO	Connector	Input Voltage & Signal
1	P1[Z SUS B/D]	5V, Va, Vs
2	P5[Y SUS B/D]	Vs
3	P6[Y SUS B/D]	5V
4	P31[CTRL B/D]	Video Signal

NO	Part No.		Description
①	6871QCH034A	PWB(PCB) ASSY	LVDS CTRL B/D ASSY
②	6871QDH066A	PWB(PCB) ASSY	Y DRV UPPER B/D ASSY
③	6871QDH067A	PWB(PCB) ASSY	Y DRV LOWER B/D ASSY
④	6871QRH037A	PWB(PCB) ASSY	X RIGHT B/D ASSY
⑤	6871QLH034A	PWB(PCB) ASSY	X LEFT B/D ASSY
⑥	6871QYH029A	PWB(PCB) ASSY	Y SUS B/D ASSY
⑦	6871QZH033A	PWB(PCB) ASSY	Z SUS B/D ASSY

ⅴ-. Adjustment

1. Application Object

This standard is applied to the PDP42V6#### PDP Module which is manufactured by the manufacturing team of PDP promotion department or elsewhere.

2. Notes

- (1) Without any special specification, the Module should be at the condition of preliminaries more than 10minutes before adjusting.
 - Service signal : 100% Full White signal
 - Service DC voltage : Vcc: 5V, Va: 65V, Vs: 185V
 - DC/DC Pack voltage : Vsetup: 200V, Vscw: 115V, -Vy: -75V
 - Preliminaries environment : Temp (25±5°C), Relative humidity (65±10%)
- (2) Module should get the Aging for the equilibrium after finish the assembling. Aging condition is shown below.
 - Service signal: 100% Full White, Red, Green, Blue pattern signal(Service time of each pattern : within 5minutes/cycle)
 - Service DC voltage : Match the voltage with the set up voltage in the first adjustment.
 - Aging time : More than 4Hrs
 - Aging environment : Temp (60±2°C), Relative humidity-Less than 75%
- (3) Module adjustment should be followed by below sequence.
 - Setting up the initial voltage and adjusting the voltage wave form of Vsetup
 - Measuring the Margin of Vs voltage and deciding the voltage
 - Adjusting and checking the voltage of DC/DC pack (Vsetup, Vscw, -Vy)
 - Adjusting the voltage wave form of Vset-down
 - Measuring the Margin of Vset-up voltage and deciding the voltage
 - Adjusting the wave form of final voltageBut, these items above can be changed by the consideration of mass production. (When changing the sequence, there should be an agreement of the Module development 2Gr./ QA Gr./ Manufacturing Gr.)
- (4) Without any special specification, you should adjust the Module in the environment of Temp (25±5°C) and Relative humidity (65±10%)

Caution If you let the still image more than 10 minutes(especially The Digital pattern or Cross Hatch Pattern which has clear gradation), after image can be presented in the black level part of screen.

3. Adjustment items

3-1. Adjusting the Board Group

- (1) Adjusting the voltage wave form of Vset-up
- (2) Adjusting the voltage wave form of Vset-down
- (3) Adjusting the voltage wave form of Vramp

3-2 Adjustment after assembling

(PDP Module adjustment)

- (1) Setting up the initial voltage and adjusting the voltage wave form of Vsetup
- (2) Measuring the voltage Margin of Vs and deciding the voltage
- (3) Adjusting and checking the voltage of DC/DC pack (Vsetup, Vscw, -Vy)
- (4) Adjusting the voltage wave form of Vset-down
- (5) Measuring the Margin of Vset-up voltage and deciding the voltage
- (6) Adjusting the wave form of final voltage

4. Adjusting the Board Group

(Applying the Jig Set)

4-1. Using Tools

- (1) Digital oscilloscope : More than 200MHz
- (2) DVM(Digital Multimeter) : Fluke 87 or similar one
- (3) Signal generator : VG-825 or similar one
- (4) DC power supply
 - DC power supply for Vs (1) : Should be changeable more than 0-200V/ more than 10A
 - DC power supply for Va (1) : Should be changeable more than 0-100V/ more than 5A
 - DC power supply for 5V (1) :Should be changeable more than 0-10V/ more than 10A
 - DC-DC Converter Jig (1) : The Jig which has voltage equivalent output of PDP42V6#### Module after taking the Vs, Va, 5V voltage
 - Voltage stability of power supply : Within ±1% for Vs/Va, within ±3% for 5V

4-2. Connection diagram of measuring instrument and setting up the initial voltage

- (1) Connection diagram of measuring instrument
Refer to Fig. 1.(Connection diagram of measuring instrument that adjusting the voltage wave form)
- (2) Setting up the initial voltage
Initially setting up voltage : Vcc: 5V, Va: 65V, Vs: 185V
But, Initially setting up voltage can be changed by the set up range according to the Module's characteristic.

4-3. How to Adjust

- (1) Adjusting the Voltage Wave form of Vsetup
 - Connect measuring instrument like the connection diagram Fig. 1.
 - Turn on the power of the measuring instrument like the <Caution> item Fig. 1.
 - Connect the oscilloscope probe to P4 connector(80 Pin) of Y-SUS PCB and GND.
 - Turn the VR1 of Y-SUS PCB and make the "A" wave form Fig. 2 to be 20±1μs.

- (2) Adjusting Vset-down Voltage Wave form
Turn the VR2 of Y-SUS PCB and make the "B" wave form Fig. 2 to be $150\pm 5\mu s$.

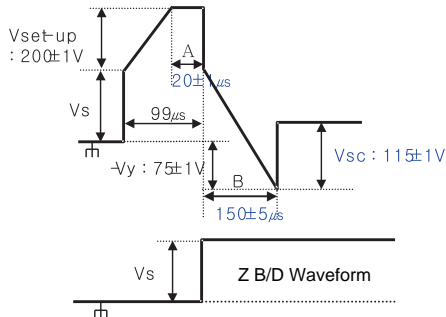

(Fig. 2) Y, Z set-up Waveform

- (3) Adjusting the Voltage Wave form of Vramp
 Connect oscilloscope Probe to the B37 Pin on Z PCB and the GND.
 Turn the VR3 of Z PCB and make the "C" wave form Fig. 3 to be $7\mu s$.

But, in case of not setting up the Test point, produce same output and adjust wave form connect to other pattern or parts which has no possibility of short.

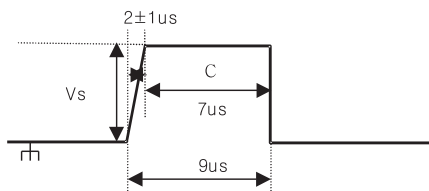

(Fig. 3) Z ramp Waveform

5. Adjustment after Assembling (PDP Module Adjustment)

5-1. Using Tools

- (1) Digital oscilloscope : More than 200MHz
- (2) DVM(Digital Multimeter): Fluke 87 or similar one
- (3) Signal generator: VG-825 or similar one
- (4) DC power supply
 - DC power supply for Vs (1) : Should be changeable more than 0-200V/ more than 10A
 - DC power supply for Va (1) : Should be changeable more than 0-100V/ more than 5A
 - DC power supply for 5V (1) : Should be changeable more than 0-10V/ more than 10A
 - DC-DC Converter Jig (1) : The Jig which has voltage equivalent output of PDP42V6#### Module after taking the Vs, Va, 5V voltage
 - Voltage stability of power supply : Within $\pm 1\%$ for Vs/Va, within $\pm 3\%$ for 5V

5-2. Connection diagram of measuring instrument and setting up the initial voltage

- (1) Connection diagram of measuring instrument
Refer to figure 1. (Connection diagram of measuring instrument that adjusting the voltage wave form)
- (2) Setting up the initial voltage
Initially setting up voltage : Vcc: 5V, Va: 65V, Vs: 185V

But, Initially setting up voltage can be changed by the set up range according to the Module's characteristic.

5-3. How to Adjust

(1) Adjusting initial voltage wave form

Check the voltage wave form like the mentioned way on the 4-3(How to adjust) and readjust the wave form when it is wrong.

(2) Checking the DC/DC pack voltage

- Convert the signal of signal generator to the 100% Full White signal
- Connect the GND terminal of DVM to the R30's right leg of the Y B/D and set the Plus terminal to the left leg of R30 to check the Vscw voltage($115\pm 1V$) and when there is abnormality in voltage turn the variable resistor(VR5) of DC/DC Pack(Vscw) on Y B/D to adjust.
- Connect the GND terminal of DVM to the R31's right leg of the Y B/D and set the Plus terminal to the left leg of R31 to check the -Vy voltage($-75\pm 1V$) and when there is abnormality in voltage turn the variable resistor(VR6) of DC/DC Pack(-Vy) on Y B/D to adjust.
- Connect the GND terminal of DVM to the R27's right leg of the Y B/D and set the Plus terminal to the left leg of R27 to check the Vsetup voltage($200\pm 1V$) and when there is abnormality in voltage turn the variable resistor(VR4) of DC/DC Pack(Vsetup) on Y B/D to adjust.

(3) Measuring the Vs voltage Margin and deciding the voltage

- Convert the signal of signal generator to the 100% Full Red signal.
- Turn the voltage adjusting knob of Vs DC power supply to the voltage -down direction and make the cell of screen turned off.
- Turn the voltage adjusting knob of Vs DC power supply to the voltage -up direction until the cell of screen turned on. The first voltage, which make the cell of full screen turned on, is named as Vsmin1 and record it.
- Turn the voltage adjusting knob of Vs DC power supply to the voltage-up direction slowly until the cell of screen turned off or over electric discharge. The first voltage, which makes the cell of screen turned off or over electric discharge, is named as Vsmax1 and records it. (Only, Vs voltage variable passes over the maximum 190V)
- Convert the signal of signal generator to the 100% Full Green signal.
- Repeat the adjustment (2) item and name each voltage as Vsmin2/Vsmax2 and record them.
- Convert the signal of signal generator to 100% Full Blue signal.
- Repeat the adjustment (2) item and name each voltage as Vsmin3/Vsmax3 and record them.
- Convert the signal of signal generator to 100% Full White signal.
- Repeat the adjustment (2) item and name each voltage as Vsmin4/Vsmax4 and record them.
- Convert the signal of signal generator to 100% Full Black signal.
- Repeat the adjustment (2) item and name each voltage as Vsmin5/Vsmax5 and record them.
- At this time decided Vs voltage adds 6V to Max value(Vsmin1~Vsmin5) and set up the voltage within the set-up range($180V < Vs \leq 190V$) in consideration of other features.
- Turn the voltage adjusting knob of Vs DC power supply make deciding the Vs voltage.
- Adjust Vset-down wave form using setting up Vs voltage like mentioned on the 4-3.

(4) Adjusting the final voltage wave form

Check the voltage wave form like the mentioned way on the 4-3(How to adjust) and readjust the wave form when it is twisted.

(5) DC-DC Pack Voltage Set up Range

Vsetup : 185V ~ 225V

Vsc : 90V ~ 120V

-Vy : -60V ~ -80V

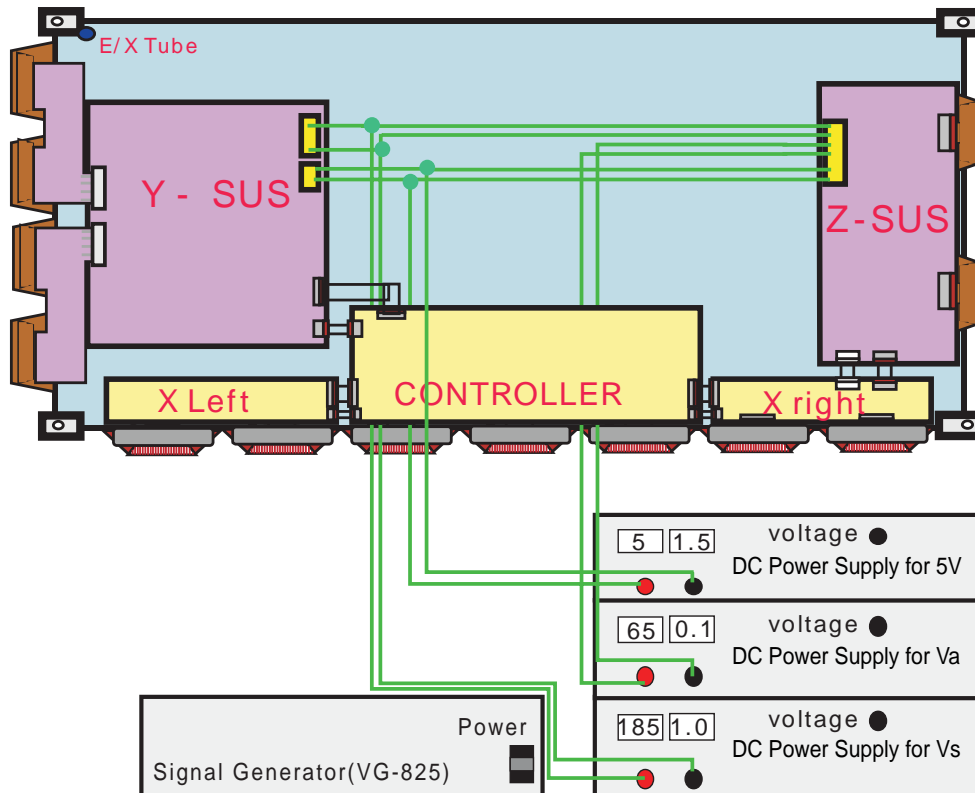

- <Caution>**
- (1) The power of the signal generator should be turned on before turning on the power of DC power supply.
 - (2) The voltage of DC power supply , in standard of Module input voltage, should be preset as below.
Vcc: 5V, Va: 65V, Vs: 185V
 - (3) The power of power supply must turned on by this sequence. Reverse direction When turning off.
* Module on : 5V ⇒ Va ⇒ Vs, Module off: Vs ⇒ Va ⇒ 5V
 - (4) Signal generator should be selected with 852*480(WVGA) mode

(Fig. 1) Connection diagram of measuring instrument

Ⅳ. Trouble Shooting

1. Checking for no Picture

A screen doesn't display at all and condition of black pattern or power off.

- (1) Check whether the CTRL B/D LED(D10, D11, D12, D13, D17) is turned on or not.
- (2) Check the power and signal cable of CTRL B/D.
- (3) X B/D, Y B/D, Z B/D is well plugged in.
- (4) Check the connection of X B/D, Y B/D and Z B/D to CTRL B/D.
- (5) Measure the output wave of X, Y, Z B/D with oscilloscope(more than 200MHz) and find the trouble of B/D by comparing the output wave with below figure.
 - Measure Point fo Y B/D : TP(Bead B103)
 - Measure Point fo Z B/D : TP(Bead B37)
 - Measure Point fo X B/D : COF TP
- (6) Check the SCAN(Y side) IC
- (7) Check the DATA(X side) COF IC
- (8) Replace the CTRL B/D.

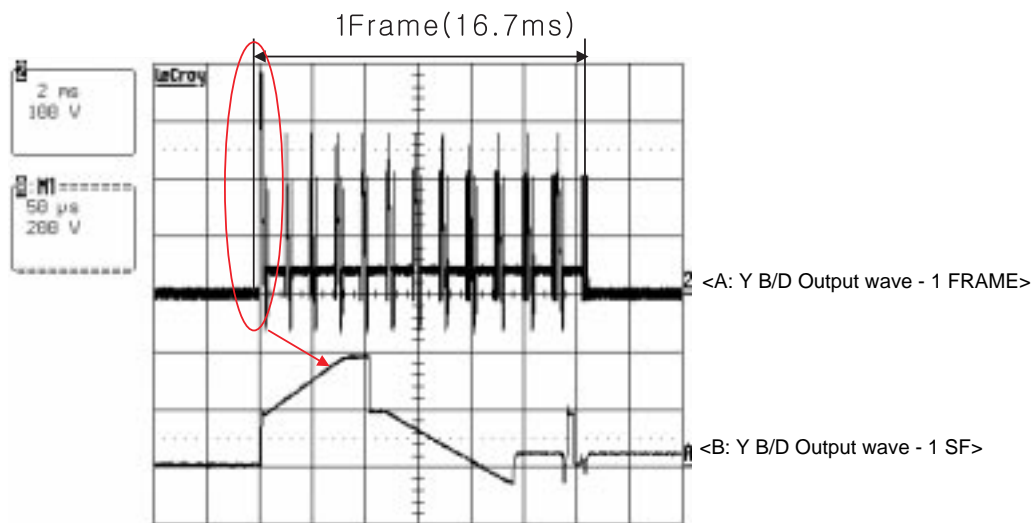

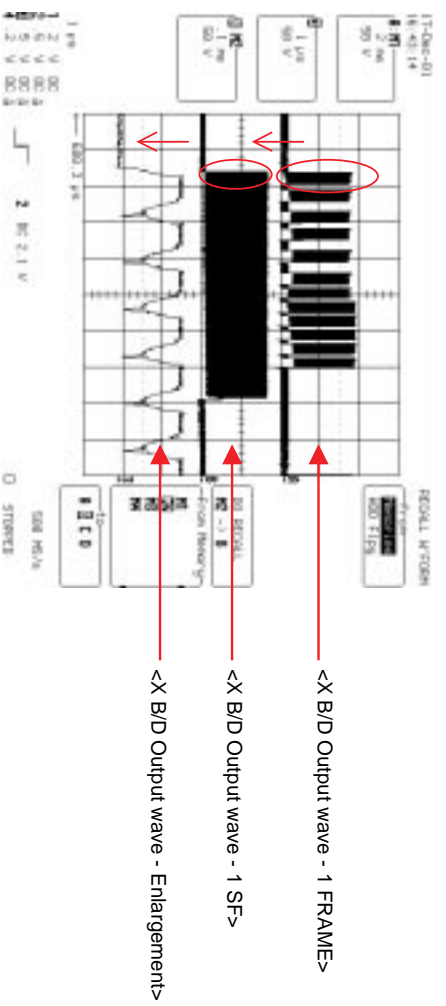
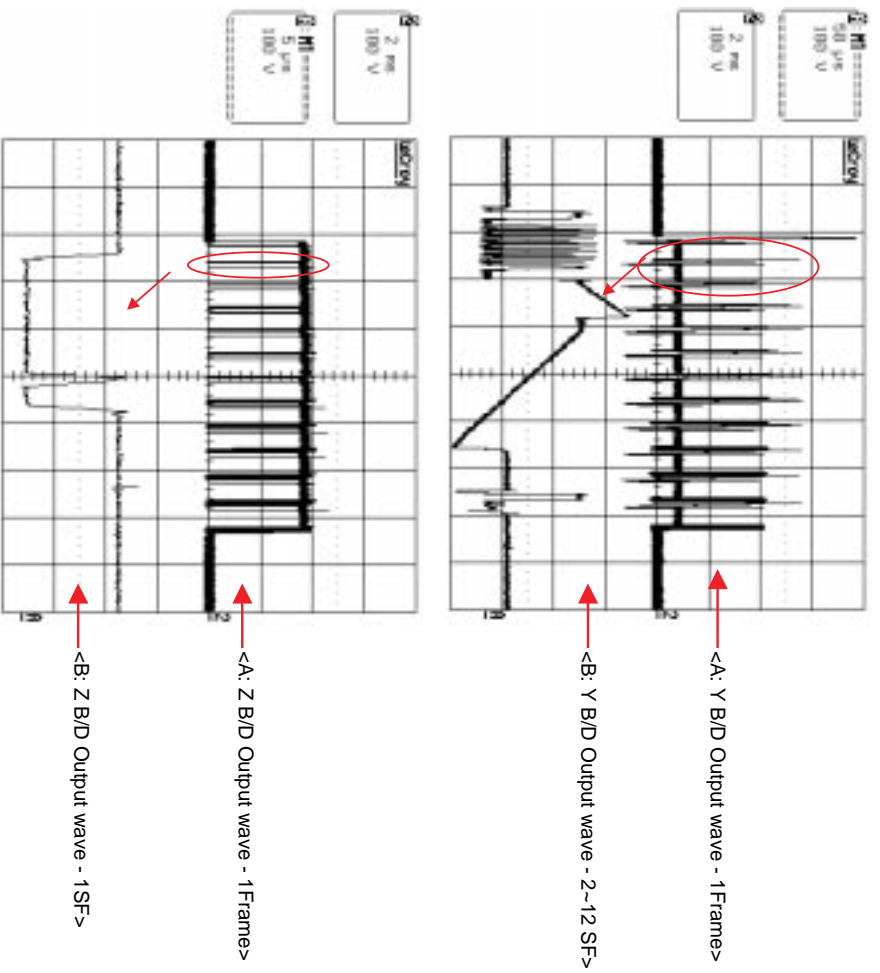

2. Hitch Diagnosis Following Display Condition

2-1. 4/7 or 3/7 of the screen doesn't be shown

- (1) Confirm the power connector of X B/D is well plugged in which is correspond to not showing screen.
- (2) Confirm the connector that is connected between CTRL B/D and X B/D correspond to not showing part.
- (3) Replace relevant X B/D.

* Relationship between screen and X B/D

Screen		X B/D
Left of the Screen 4/7	<-->	Right X B/D
Right of the Screen 3/7	<-->	Left X B/D

* Screen Display Form

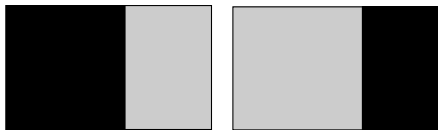

Left of the Screen(4/7) Right of the Screen(3/7)

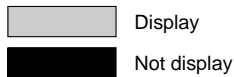

2-2. The screen doesn't be shown as Data COF

(Include not be shown part of Data COF quantity or a part)

- (1) The problem between Data COF and X B/D is more possible that the screen is not be shown as data COF.
- (2) Confirm the connector of Data COF is well connected to X B/D. Correspond to the part that screen is not showing
- (3) Confirm whether the Data COF is failed and replace X B/D

* Example of the screen display form

(Anything of the 7 Data COF can be shown beside below pictures)

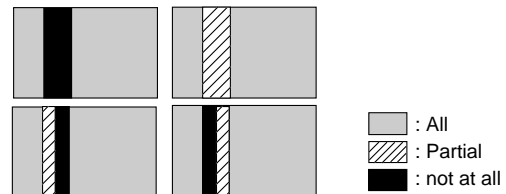

* How to examine Data COF IC

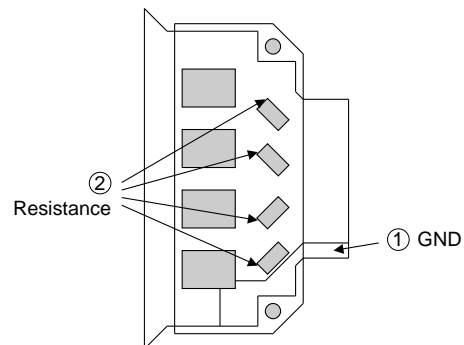

- Change ' ① GND' into ANODE, ' ② Resistance' into CATHOD and then examine the Diode to the forward or reverse direction.
- Measure the resistance value(10Ω)

2-3. It Generates Unusual Pattern of Data COF IC unit

- (1) In case of generating unusual pattern of Data COF IC unit as below picture, there is problem in the check that is input into Data COF IC
- (2) In case of <case 1, 2, 3>
 - confirm the connection of Data COF connector
 - replace the relevant X B/D
- (3) In case of <case 4, 5>
 - confirm the connector that is connected from CTRL to X B/D
 - Replace relevant XB/D or CTRL B/D

2-4. Regular Stripe is Generated about the Quantity of one Data COF IC or more

- (1) In case of generating regular stripe about the quantity of one Data COF IC, there is problem at the output of output-flatworm of X B/D
 In case of generating regular stripe about the quantity of two Data COF IC, that means the data which is conveyed from CTRL B/D doesn't conveyed well.
- (2) Confirm the XB/D connection connector plugged in well. Correspond to unusual screen.
- (3) Replace relevant XB/D or CTRL B/D.

* Screen Display Form

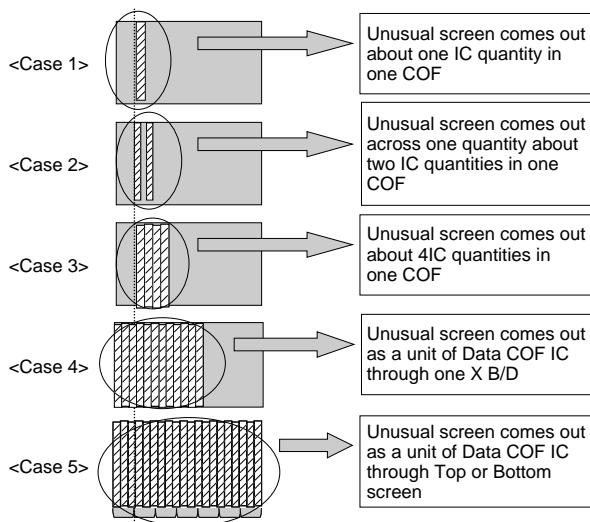

* Relationship between screen and X B/D

Screen		X B/D
Left of the Screen	4/7 <-->	Right X B/D
Right of the Screen	3/7 <-->	Left X B/D

* Screen Display Form

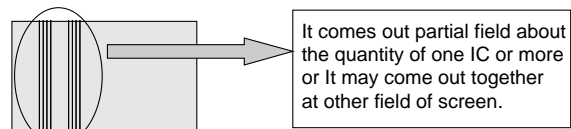

2-5. The screen display has a problem for Scan FPC.

- (1) It's may be a problem between Scan FPC and Y B/D.
- (2) Check the connection of Y B/D and Scan FPC.
- (3) If the Scan IC is failed, replace the Y DRV B/D.

*** Screen Display Form**

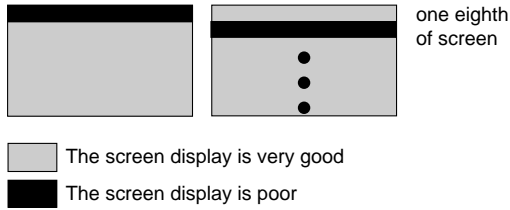

*** Check a method of SCAN IC**



Change the Vpp Pin into ANODE and GND Pin into CATHOD and then test the Diode with forward or reverse direction.

**2-6. The screen has a vertical line with regular gap.
(A vertical stripe flash at especial color)**

- (1) This is a problem about control B/D.
- (2) Replace Control B/D.

*** Screen Display Form**

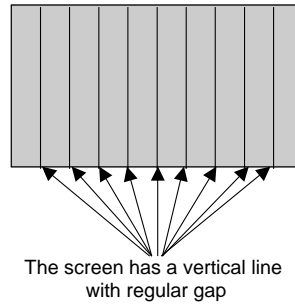

2-7. A data copy is happened into vertical direction

- (1) In this case, it's due to incorrect marking of scan wave.
- (2) Replace a Y DRV B/D or Y SUS B/D.

*** Screen Display Form**

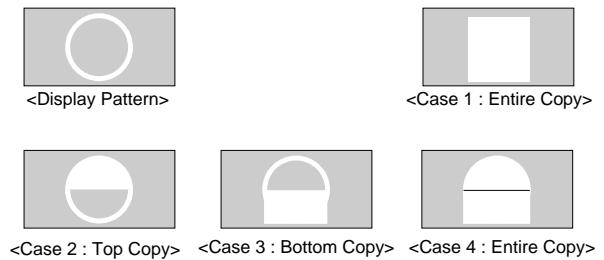

2-8. The screen has one or several vertical line

- (1) In this case, It isn't a problem about controller B/D or X B/D.
- (2) It may cause followings.
 - It's out of order a panel
 - Open or short of DATA COF FPC attached panel
 - It's out of order a DATA COF attached panel
- (3) Replace Module.

* Screen Display Form

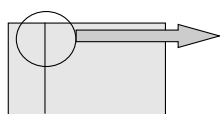

It may show several vertical lines in a quarter or other division part of screen including left case.

2- 9. The screen has one or several horizontal line

- (1) In this case, it isn't a problem about controller B/D or X B/D.
- (2) It may cause followings.
 - It's out of order a panel
 - Open or short of SCAN FPC attached panel
 - It's out of order a SCAN IC attached panel
- (3) Replace Y DRV B/D

* Screen Display Form



It may show several horizontal lines including left case.

2-10. The screen displays input signal pattern but the brightness is dark

- (1) In this case, Z B/D operation isn't complete.
- (2) Check the power cord of Z B/D.
- (3) Check the connector of Z B/D and Controller B/D.
- (4) Replace the Controller B/D or Z B/D.

2-11. The screen displays other color partially on full white screen or happens discharge partially on full black screen.

- (1) Check the declination of Y B/D set up, set down wave.
- (2) Check the declination of Z B/D ramp wave.
- (3) Measure each output wave with oscilloscope(more than 200MHz) and compare the data with below figure data. Adjust the Y B/D set up(Test-up:B/C[μ s/ μ s])/setdown(Test-down:D[μ s]) and Z B/D ramp(Tramp:F/G[μ s/ μ s]) declination by changing VR1/VR2/VR3.
 - Measuring Point of Y B/D : B103(SUS_UP)
 - Measuring Point of Z B/D : B37(SUS_OUT)

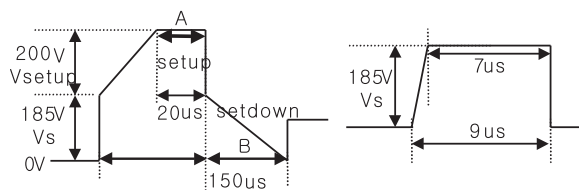

Y Output Voltage Wave form

Z RAMP Voltage Wave form

**2-12. A center of screen is darker than
a edge of screen at full white pattern.**

- (1) In this case, it's a problem about Z B/D ramp wave.
- (2) Check the connection cable of Z B/D and CTRL B/D.
- (3) Replace the Z B/D.

*** Screen Display Form**



**2-13. It doesn't display a specified
brightness at specified color**

- (1) Check the connector of CTRL B/D input signal.
- (2) Replace the CTRL B/D.

3. Checking for component damage

3-1. Y IPM(IC 12) or Z IPM(IC 4) damage

- (1) When the internal Sustain_FET of Y IPM(IC 12) or Z IPM(IC 4) is damaged, screen doesn't be shown or electric discharge is generated.
 - Test Point: GND~B103(Y B/D), GND~B37(Z B/D)
 - Wave format: B103(Y B/D) or B37(Z B/D) has no wave output
- (2) When the internal ER_FET of Y IPM(IC 12) or Z IPM(IC 4) is damaged, Y IPM or Z IPM emission is increased.
 - Test Point: GND~B103(Y B/D), GND~B37(Z B/D)
 - Wave format: As shown (Fig. 1)

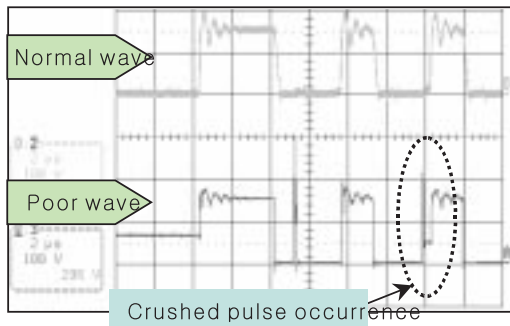

(Fig. 1) When the ER_FET is damaged

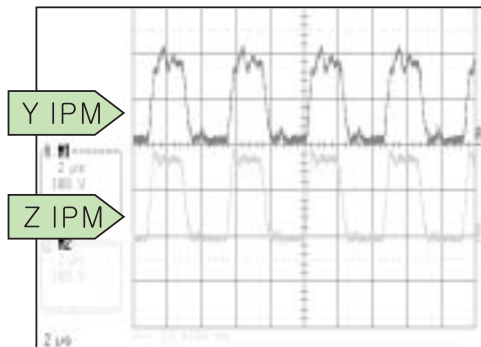

<IPM Normal Output Wave >

- Measrance position: Sustain section enlarge the after measuring B103 wave of Y B/D and B37 wave of Z B/D. (Full White Pattern)

3-2. FET Ass'y(Y B/D: HS1) damage

- (1) When Set_Up FET is damaged, screen doesn't be shown
 - Test Point: Enlarge the after measuring GND~B103(Y B/D)
 - Wave format: As shown (Fig. 2)

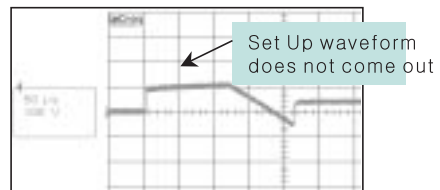

(Fig. 2) When the Set_Up FET is damaged

- (2) When Set_Down FET is damaged, electric discharge of entire screen is generated.
 - Test Point: Enlarge the after measuring GND~B103(Y B/D)
 - Wave format: As shown (Fig. 3)

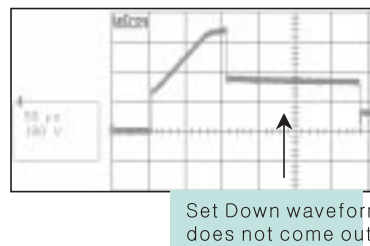

(Fig. 3) When the Set_Down FET is damaged

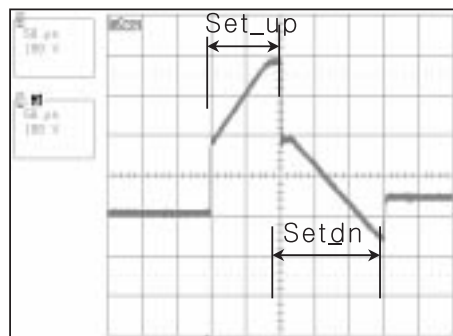

<FET Ass'y Normal Output Wave >

- Measrance position: Reset section enlargement wave of TP B103(Y B/D) (Full White Pattern)

3-3. SCAN IC(Y drv B/D: IC1~8) damage

(1) In case of SCAN IC poor, one horizontal line may open at screen.

- Test Point: ICT measurement of GND~Y drive B/D output
- Wave format: As shown (Fig. 4)

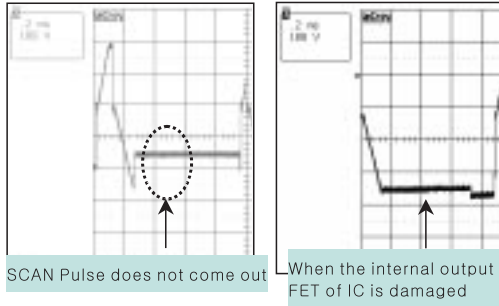

(Fig. 4) When SCAN IC is poor

(2) Screen may not shown when SCAN IC is damaged by SCAN IC poor, external electricity or spark.

- Test Point: ICT measurement of GND~Y drive B/D output
- Wave format: Output wave format isn't output (You can see the damage for Y drive B/D Top or Bottom's SCAN IC)

(3) Screen shaken horizontally when Y drv B/D Top and Bottom cable is poor

- Test Point: ICT measurement of GND~Y drive B/D output
- Wave format: As shown (Fig. 5)

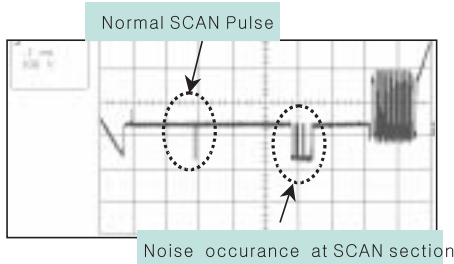

(Fig. 5) When Y drv B/D Top and Bottom cable is poor

(4) In case of shorting the SCAN IC output by a dust, foreign substance, it may overlap two horizontal lines on screen.

- Test Point: ICT measurement of GND~Y drive B/D output
- Wave format: As shown (Fig. 6)

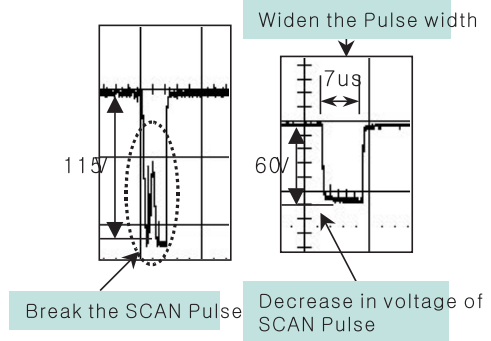

(Fig. 6) When SCAN IC output is short

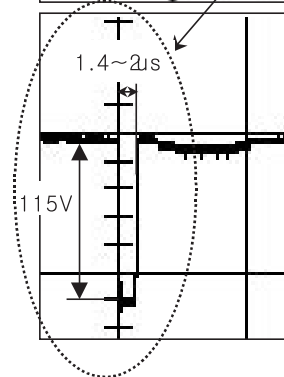
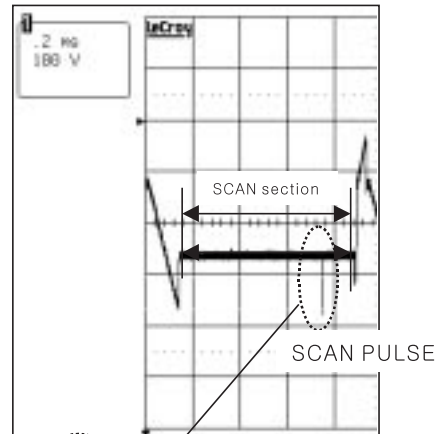

<SCAN IC Normal Output Wave >

- Measurement position: SCAN section enlarge the after measuring output ICT of Y drive B/D. (Full White Pattern)

3-4. COF damage

- (1) In case of shorting or opening the IC output of COF, it may show one or several vertical lines.
- Test Point: Enlarge the after measuring output TP of GND-COF
 - Wave format: As shown Output of (Fig. 7)
- In case of normal wave output, when STB signal is generated, maintain High output. And when STB signal is generated again must be fall Low. But when IC of COF is poor, STB signal is not generated Output falls with Low.

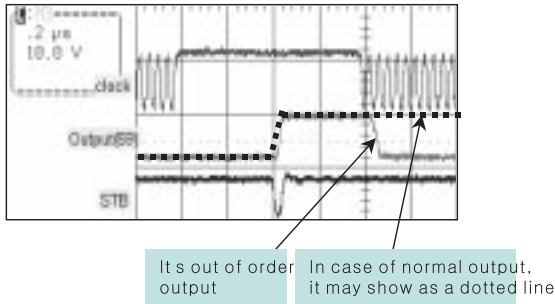

(Fig. 7) When IC output of COF is poor

- (2) In case of being damage IC of COF or power resistance, the screen doesn't be shown or happens discharge partially.
- Test Point: Enlarge the after measuring output TP of GND-COF
 - Wave format: Output wave doesn't come out

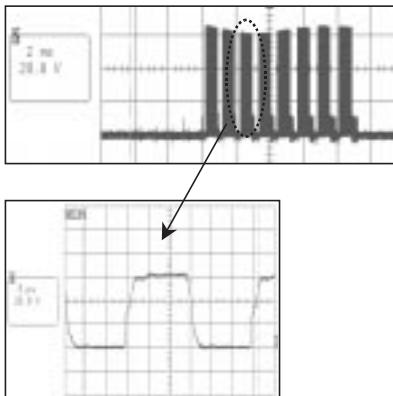

<COF Normal Output Wave >

- Measurement position: Enlarge the after measuring output TP of COF (Full White Pattern)

3-5. Crystal(CTRL B/D: X1) damage

- (1) When Crystal is damage, the screen doesn't be shown.
- Test Point: Measuring 3pin of GND-Crystal(Ctrl B/D: X1)
 - Wave format: Output wave doesn't come out
- (2) In case of unusual launch of the Crystal, it may blink the screen.
- Wave format: As shown (Fig. 8)

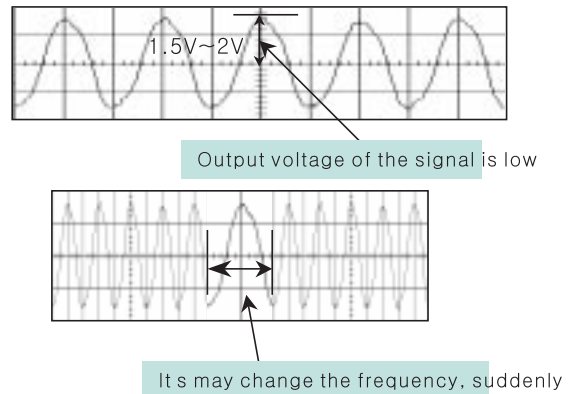

(Fig. 8) When Crystal is poor

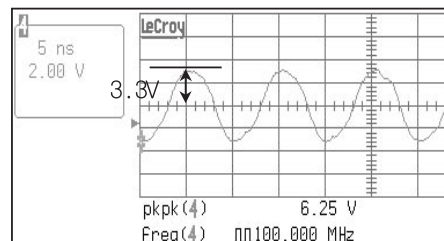

<Crystal Normal Output Wave >

- Measurement position: Measuring output 3pin of Crystal(X1: 100MHz) on Ctrl B/D (Full White Pattern)

⚠ Block Diagram

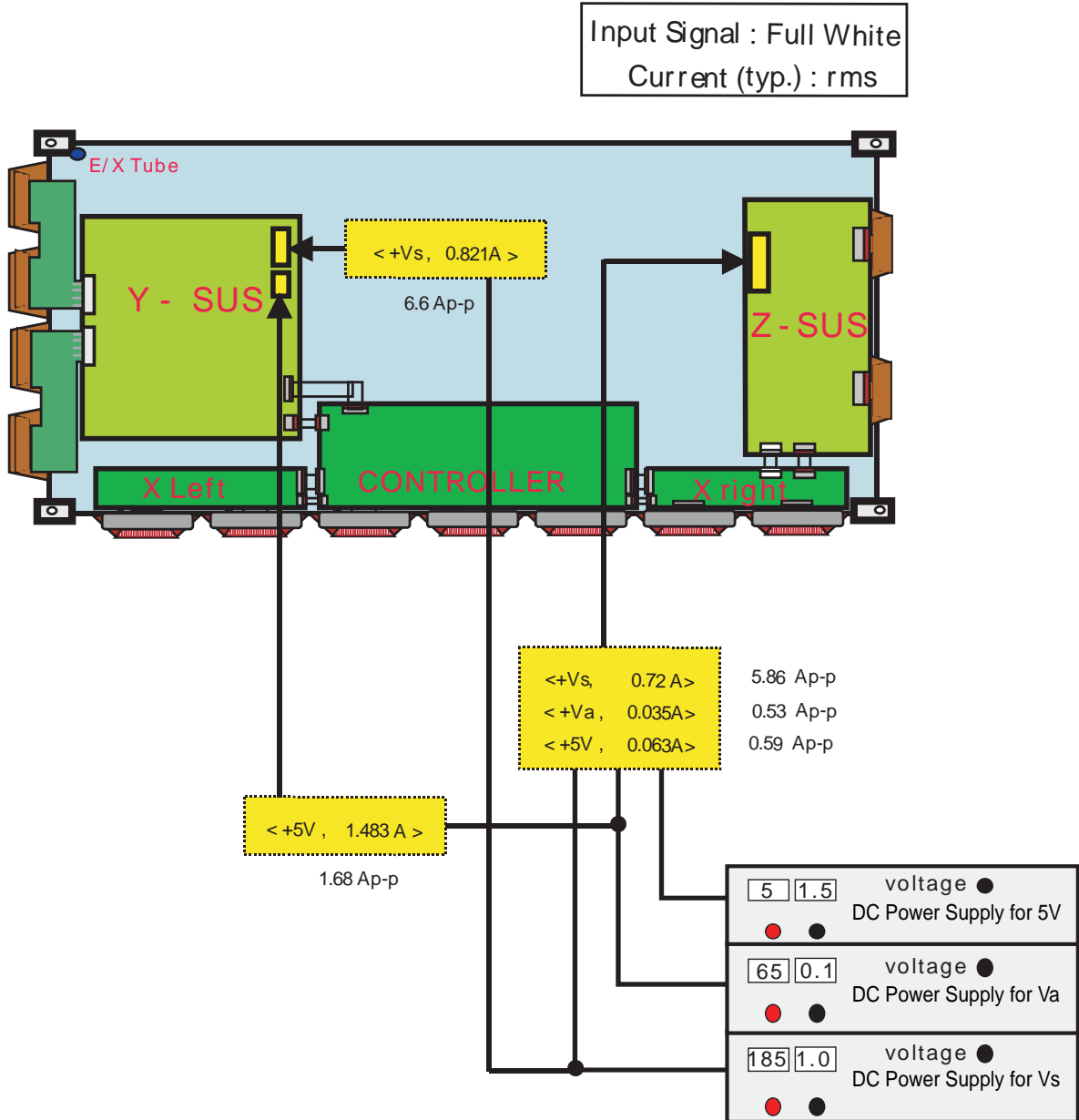

Ⅳ -. Records of Revision for Boards, components and ROM DATA

1. Boards

No.	Date	Board	Part Number	Note
1	2004.01.21	CTRL B/D ASSY(LVDS)	6871QCH034A	Initial Product
2	2004.01.21	YDRV Upper B/D ASSY	6871QDH066A	Initial Product
3	2004.01.21	YDRV Lower B/D ASSY	6871QDH067A	Initial Product
4	2004.01.21	Y SUS B/D ASSY	6871QYH029A	Initial Product
5	2004.01.21	Z SUS B/D ASSY	6871QZH033A	Initial Product
6	2004.01.21	X RIGHT B/D ASSY	6871QRH037A	Initial Product
7	2004.01.21	X LEFT B/D ASSY	6871QLH034A	Initial Product
8	2004.02.23	CTRL B/D ASSY(LVDS)	6871QCH034A	COF Resistor added
9	2004.02.23	Y SUS B/D ASSY	6871QYH029A	R90, R91, C33, P5, P6 changed
10	2004.02.23	Z SUS B/D ASSY	6871QZH033A	C7 added
11	2004.02.23	X RIGHT B/D ASSY	6871QRH037A	4 layers changed
12	2004.02.23	X LEFT B/D ASSY	6871QLH034A	4 layers changed

2. COMPONENTS

No.	Date	COMPONENT	Part Number	Remark
1	2004.01.21	Y IPM(Y B/D: IC 12)	4921QP1023A	Initial Product Apply to DRIVER IC: IR2113S
2	2004.01.21	Z IPM(Z B/D: IC 4)	4921QP1024A	Initial Product Apply to DRIVER IC: IR2113S
3	2004.01.21	FET(Y B/D: HS1)	4921QF2004A	Initial Product Set_up/Set-dn FET Ass'y
4	2004.01.21	COF	0ILNRAZ015D	Initial Product Check the inner resistance in 0 Ohm
5	2004.01.21	Crystal(CTRL B/D: X1)	6212AB4004A	Initial Product
6	2004.01.21	SCAN IC(Y drive B/D: IC1~8)	0ILNRMA011A	Initial Product Matsushida: AN16001A
7	2004.03.01	COF	0ILNRHS001A	Check the inner resistance in 10 Ohm
8	2004.04.05	SCAN IC(Y drive B/D: IC1~8)	0ILNRTI020A	TI: SN755866
9	2004.04.05	Y IPM(Y B/D: IC 12)	4921QP1025A	Apply to DRIVER IC: IXYS
10	2004.04.05	Z IPM(Z B/D: IC 4)	4921QP1026A	Apply to DRIVER IC: IXYS

3. ROM DATA

No.	Date	ROM Data Version	Contents
1	2004.02.18	42V62MS01	Initial ROM Data for DND
2	2004.02.18	42V62JN01	Initial ROM Data for HTC

SPARE PART LIST

V6 (LG)

Parts Code	Description
X56101	PCB ASSY LVDS LV42V6 (6871QCH034A)
X56103	PCB ASSY Y-DRIVE UP LG42V6 (6871QDH066A)
X56104	PCB ASSY Y-DRIVE(UST) LG42V6 (6871QDH067A)
X56105	PCB ASSY X-DRIVE(LEFT)LG42V6(6871QLH034A)
X56106	PCB ASSY X-DRIVE(LEFT)LG42V6 (6871QRH037A)
X56107	PCB ASSY YSUS LG42V6 (6871QYH029A)
X56108	PCB ASSY XSUS LG42V6 (6871QZH033A)
X56109	PCB ASSY SMPS(PSU) LG42V6 (6709Q00150A)

DATE: July 15, 2004



107cm (42 Inch) Wide Plasma Display Module

MODEL : 42" S3.1 PDP



CONTENTS

1. Overview

- 1-1 Model Name of plasma Display
- 1-2 External View
- 1-3 Specifications

2. Precaution

- 2-1 Handling Precaution for Plasma Display,
- 2-2 Safety Precautions for Service (Handling, prevention of a electrical shock, measure against power outage, etc)

3. Name & Function

- 3-1 Layout of Assemblies
- 3-2 Block Diagram:
- 3-3 Main function of Each Assembly
- 3-4 Product/Serial Label Location

4. Operation checking after rectification

- 4-1 Flow chart
- 4-2 Defects , Symptoms and Detective Parts

5. Disassembling / Assembling

- 5-1 Tools and measurement equipment
- 5-2 Exploded View
- 5-3 Disassembling & Re-assembling

6. Operation Check after Repair Service

- 6-1 Check Item
- 6-2 Check Procedure

7. Operation Check

- 7-1 Adjustment Specification, Checking Position etc.
- 7-2 Adjusting procedure

8. Spare part list for the panel

1. Overview

1-1 Model Name of Plasma Display

MODEL : 42" S3.1 PDP (S42SD-YD05)

1-2 External View



【 M1 = X Board + Y Board + Logic Board 】

1-3 Specifications

No	Item	Specification	
1	Pixel	852 (H) × 480 (V) pixels (1 pixel = 1 R,G,B cells)	
2	Number of Cells	2556 (H) × 480 (V)	
3	Pixel Pitch	1.095 (H) mm × 1.110 (V) mm	
4	Cell Pitch	R	0.365 (H) mm × 1.110 (V) mm
		G	0.365 (H) mm × 1.110 (V) mm
		B	0.365 (H) mm × 1.110 (V) mm
5	Display size	932.940 (H) mm × 532.800(V) mm [36.73 inch × 20.98 inch]	
6	Screen size	Diagonal 42" Color Plasma Display Module	
7	Screen aspect	16 : 9	
8	Display color	16.77 million colors	
9	Viewing angle	Over 160° (Angle with 50% and greater brightness perpendicular to PDP module)	
10	Dimensions	982 (W) × 582 (H) × 52.9 (D) mm	
11	Weight	Module 1	About 16.6 kg
12	Packing weight	Module 1	240kg ± 5kg (including modules) / 10pcs/BOX
13	Packing size	L 1175 * W 1140 * H 970 (mm) / 10pcs/BOX	
14	Broadcasting reception	PL42SD003C	60Hz/ 50Hz, LVDS
	Vertical frequency		
	and		
	Video/Logic Interface		

2. PRECAUTIONS

**** To prevent the risks of unit damage, electrical shock and radiation, take the following safety, service, and ESD precautions.**

2-1 Handling Precautions for Plasma Display

- n PDP module use high voltage that is dangerous to human. Before operating PDP, always check the dust to prevent circuit short. Be careful touching the circuit device when power is on.
- n PDP module use a fine pitch connector which is only working by exactly connecting with flat cable. Operator must pay attention to a complete connection when connector is reconnected after repairing.
- n PDP module is sensitive to dust and humidity. Therefore, assembling and disassembling must be done in no dust place.
- n The capacitor's remaining voltage in the PDP module's circuit board temporarily remains after power is off. Operator must wait for discharging of remaining voltage during at least 1 minute.
- n PDP module has a lot of electric devices. Service engineer must wear equipment(for example , earth ring) to prevent electric shock and working clothes to prevent electrostatic.

2-2 Safety Precautions for Service (Handling, prevention of a electrical shock, measure against power outage, etc)

(Safety Precautions)

- n Before replacing a board, discharge forcibly The remaining electricity from board.
- n When connecting FFC and TCPs to the module, recheck that they are perfectly connected.
- n To prevent electrical shock, be careful not to touch leads during circuit operations.
- n To prevent the Logic circuit from being damaged due to wrong working, do not connect/disconnect signal cables during circuit operations.
- n Do thoroughly adjustment of a voltage label and voltage-insulation.
- n Before reinstalling the chassis and the chassis assembly, be sure to use all protective stuffs including a nonmetal controlling handle and the covering of partitioning type.
- n Caution for design change : Do not install any additional devices to the module, and do not change the electrical circuit design.
- n For example: Do not insert a subsidiary audio or video connector. If you insert It, It cause danger on safety. And, If you change the design or insert, Manufactor guarantee will be not effect. .
- n If any parts of wire is overheats of damaged, replace it with a new specified one immediately, and identify the cause of the problem and remove the possible dangerous factors.
- n Examine carefully the cable status if it is twisted or damaged or displaced. Do not change the space between parts and circuit board. Check the cord of AC power preparing damage.
- n Product Safety Mark : Some of electric or implement material have special characteristics invisible that was related on safety. In case of the parts are changed with new one, even though the Voltage and Watt is higher than before, the Safety and Protection function will be lost.
- n The AC power always should be turned off, before next repair..
- n Check assembly condition of screw, parts and wire arrangement after repairing. Check whether the material around the parts get damaged.

(Precaution when repairing ESD)

- n** There is ESD which is easily damaged by electrostatics.(for example Integrated circuit, FET) Electrostatic damage rate of product will be reduced by the following technics
- n** Before handling semiconductor parts/assembly, must remove positive electric by ground connection, or must wear the antistatic wrist-belt and ring. (It must be operated after removing dust on it – It comes under precaution of electric shock.)
- n** After removing ESD assembly, put on it with aluminum stuff on the conductive surface to prevent charging.
- n** Do not use chemical stuff using Freon. It generates positive electric that can damage ESD.
- n** Must use a soldering device for ground-tip when soldering or de-soldering ESD.
- n** Must use anti-static solder removal device. Most removal device do not have antistatic which can charge a enough positive electric enough damaging ESD.
- n** Before removeing the protective material from the lead of a new ESD, bring the protective material into contact with the chassis or assembly that the ESD is to be installed on.
- n** When handing an unpacked ESD for replacement, do not move around too much. Moving (legs on the carpet, for example) generates enough electrostatic to damage the ESD.
- n** Do not take a new ESD from the protective case until the ESD is ready to be installed. Most ESD have a lead, which is easily short-circuited by conductive materials (such as conductive foam and aluminum)

3.NAME & FUNCTION

3-1 Layout of Assemblies

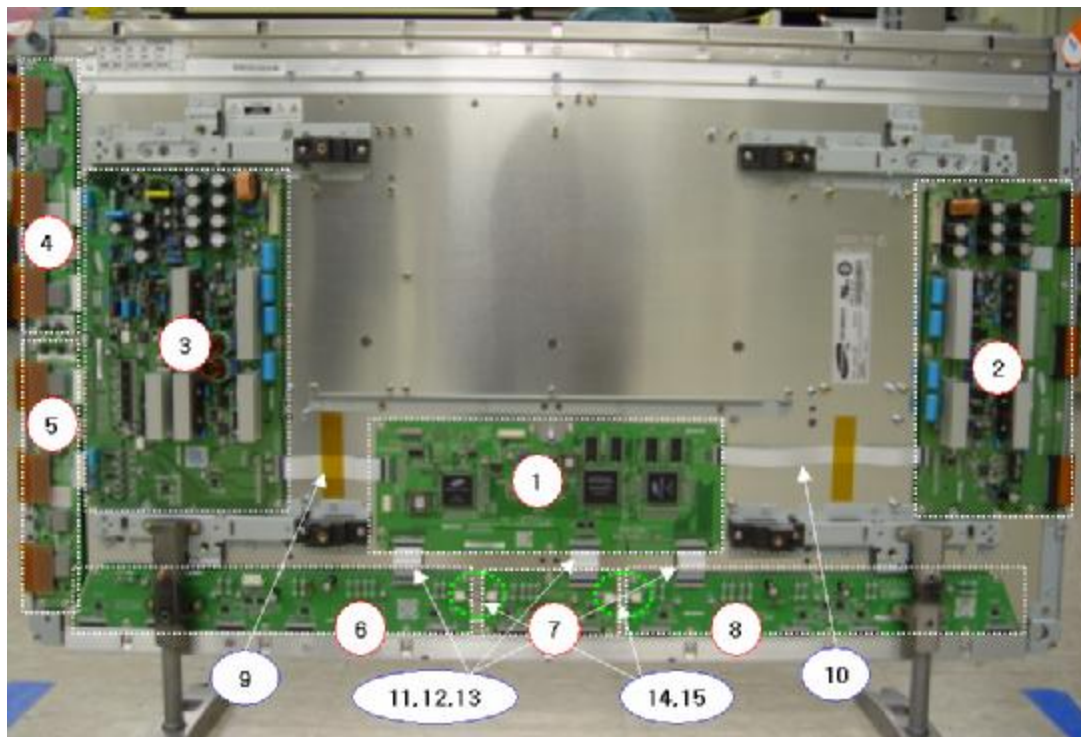

No.	Code No.	Location	品名
1	LJ92-00975A	Logic Main	ASSY PCB LOGIC MAIN
2	LJ92-00943A	X-Main	ASSY PCB X MAIN
3	LJ92-00944B	Y-Main	ASSY PCB Y MAIN
6	LJ92-00811A	Logic E Buffer	ASSY PCB BUFFER
7	LJ92-00812A	Logic F Buffer	ASSY PCB BUFFER
8	LJ92-00813A	Logic G Buffer	ASSY PCB BUFFER
9	LJ92-00796A	Y-Buffer (upper)	ASSY PCB BUFFER
10	LJ92-00797A	Y-Buffer (lower)	ASSY PCB BUFFER
11	3809-001397	Logic + Y-Main	FFC CABLE-FLAT
12	3809-001396	Logic + X-Main	FFC CABLE-FLAT
13	3809-001414	Logic + Logic Buf'(E)	FFC CABLE-FLAT
14	3809-001414	Logic + Logic Buf'(F)	FFC CABLE-FLAT
15	3809-001414	Logic + Logic Buf'(G)	FFC CABLE-FLAT
16	LJ39-00109A	Logic Buf'(E) + Logic Buf'(F)	LEAD CONNECTOR
17	LJ39-00109A	Logic Buf'(F) + Logic Buf'(G)	LEAD CONNECTOR
18	LJ39-00139A	SMPS + Video SMPS	LEAD CONNECTOR
19	LJ39-00140A	SMPS + Logic Buffer (E)	LEAD CONNECTOR
20	LJ39-00143A	SMPS + Logic Main	LEAD CONNECTOR
21	LJ39-00142A	SMPS + Y-Main	LEAD CONNECTOR
22	LJ39-00179A	SMPS + X-Main	LEAD CONNECTOR



1. L-Main

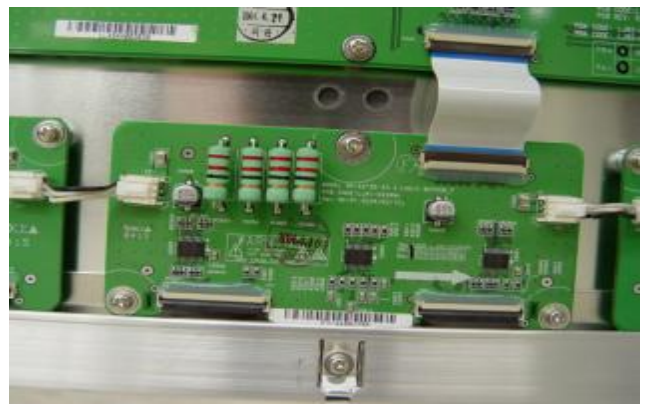

7. F-Buffer



2. X-Main



3. Y-Main

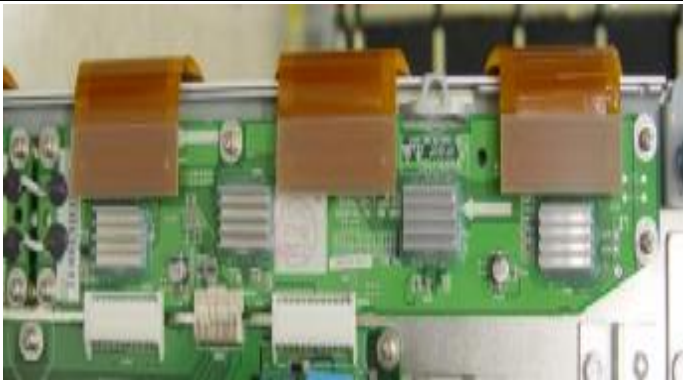

4. Y-Buffer (upper)



5. Y-Buffer (lower)



6. E-Buffer



8. G-Buffer

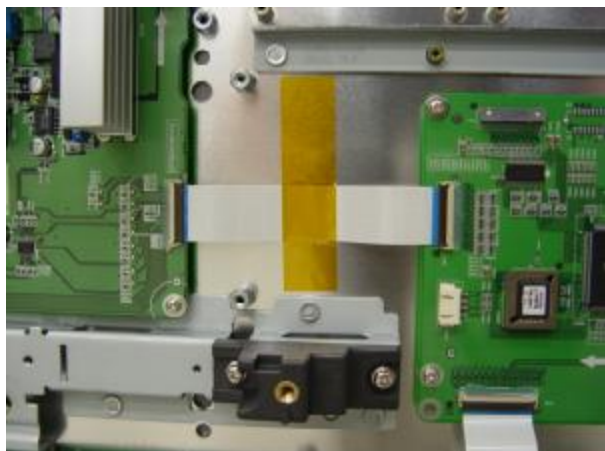

9. Logic + Y-Main

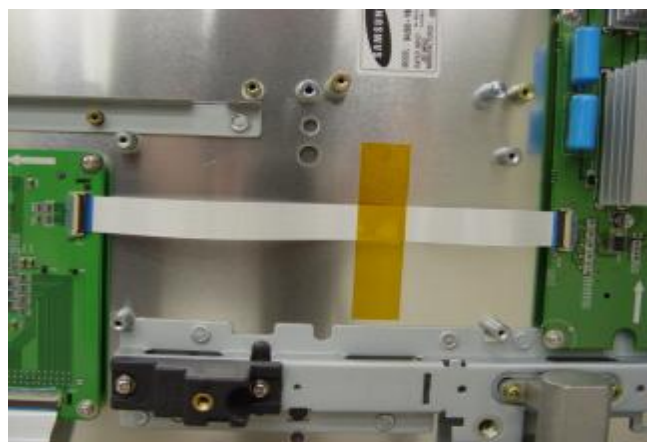

10. Logic + X-Main

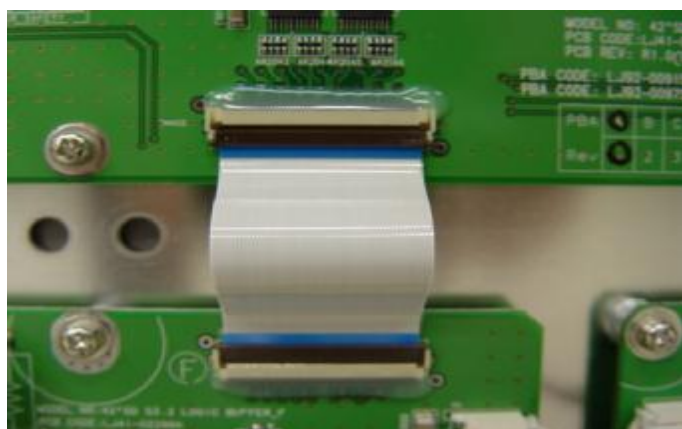

11. 12. 13. Logic + Logic Buf'(E,F,G)

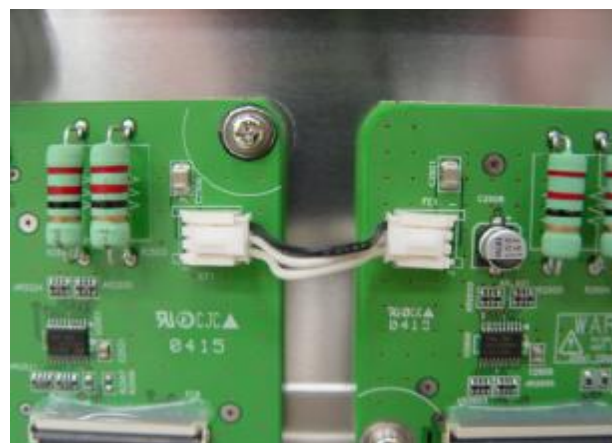

14. 15. Logic Buffer 問

3-2 BLOCK DIAGRAM

3-2-1 BLOCK DIAGRAM FOR DRIVE CIRCUIT OPERATION

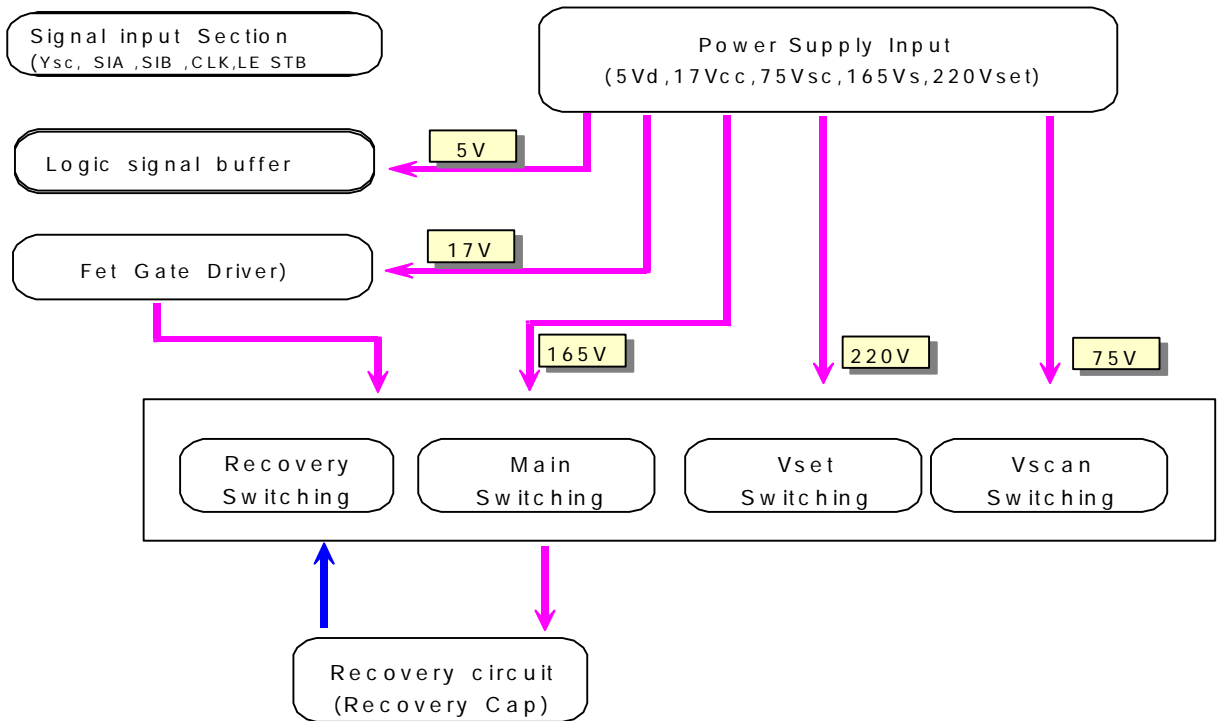

< DRIVE Y Board >

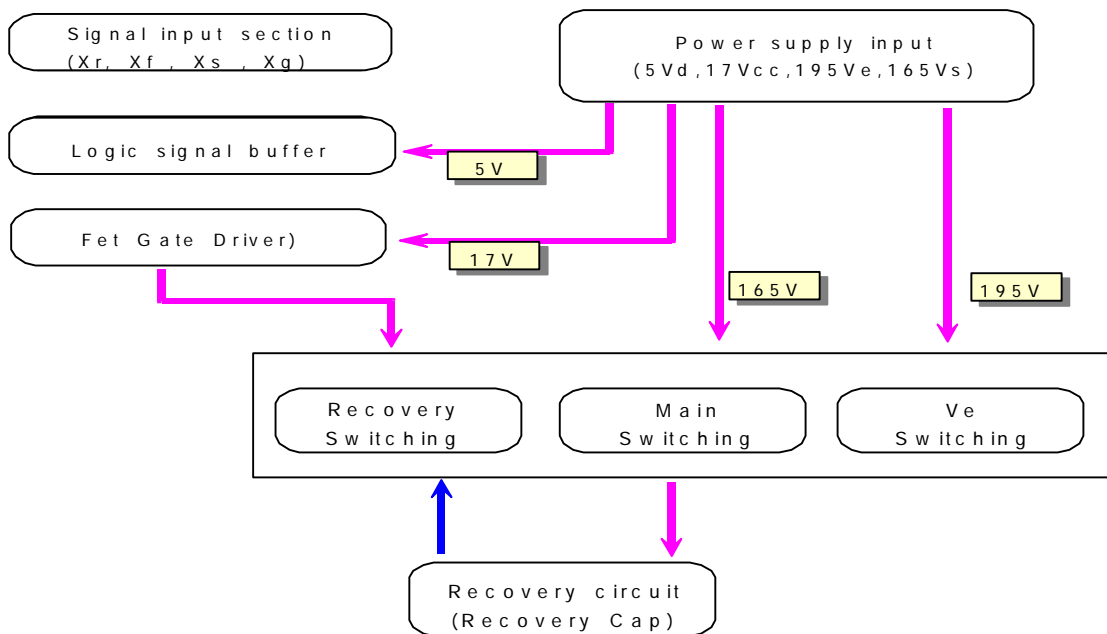

< DRIVE X Board >

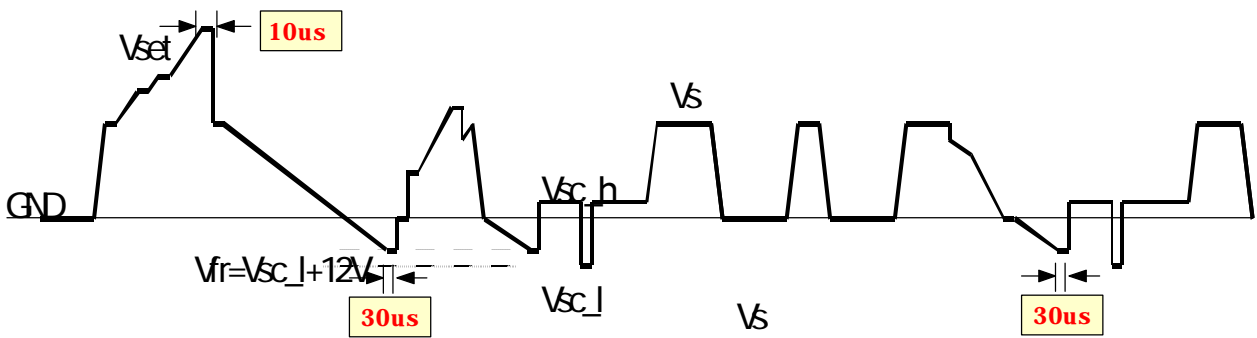
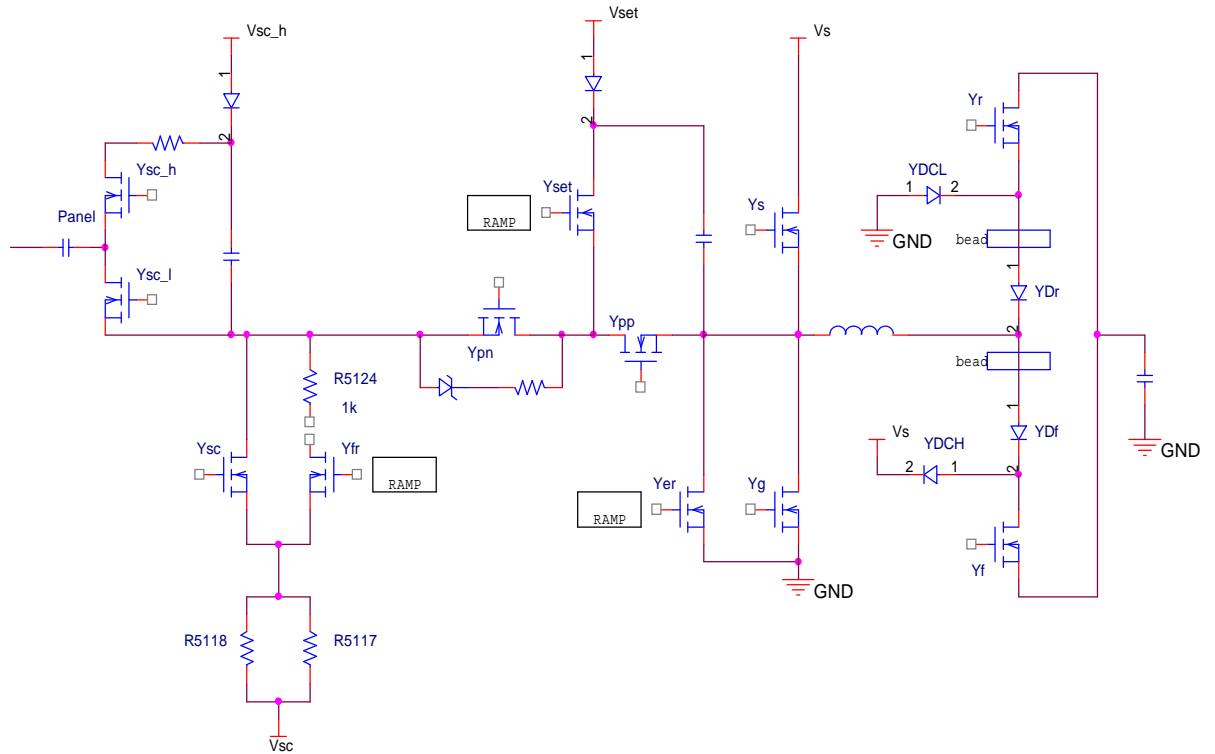

< Drive waveforms >

3-2-2 Block Diagram for Logic circuit

Logic Main Block-Diagram

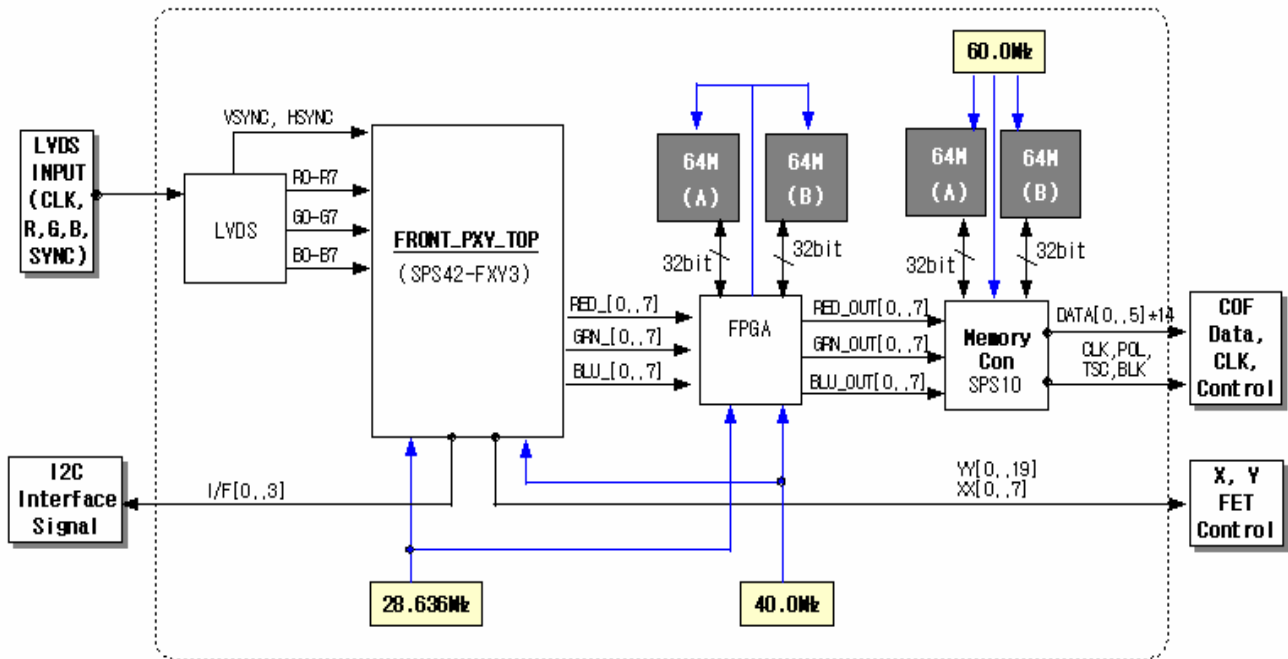

3-3 Main function of Each Assembly

- X-main board : The X-main board generate a drive signal by switching the FET in synchronization with logic main board timing and supplies the X electrode of the panel with the drive signal through the connector.
 - 1) Maintain voltage waveforms (including ERC)
 - 2) Generate X rising ramp signal
 - 3) Maintain Ve bias between Scan intervals
- Y-main board : The Y-main board generate a drive signal by switching the FET in synchronization with the logic Main Board timing and sequentially supplies the Y electrode of the panel with the drive signal through the scan driver IC on the Y-buffer board. This board connected to the panel's Y terminal has the following main functions.
 - 1) Maintain voltage waveforms (including ERC)
 - 2) Generate Y-rising Falling Ramp
 - 3) Maintain V scan bias
- Logic main board : The logic main board generates and outputs the address drive output signal and the X, Y drive signal by processing the video signals. This Board buffers the address drive output

signal and feeds it to the address drive IC (COF module)

(video signal- X Y drive signal generation , frame memory circuit / address data rearrangement)

- .Logic buffer(E,F) : The logic buffer transmits data signal and control signal.
- .Y-buffer board (Upper, Lower) : The Y-buffer board consisting of the upper and lower boards supplies the Y-terminal with scan waveforms. The board comprises 8 scan driver IC's (ST microelectronics STV 7617 : 64 or 65 output pins) , but 4 ICs for the SD class
- .AC Noise Filter : The AC Noise filter has function for removing noise(low Frequency) and blocking surge. It effects Safety standards(EMC,EMI)
- .TCP(Tape Carrier Package) : The TCP applies Va pulse to the address electrode and constitutes address discharge by the potential difference between the Va pulse and the pulse applied to the Y electrode. The TCP comprise 4 data driver Ics(STV7610A :96 pins output pins) 7 TCPs are required for signal scan .

3-4 PRODUCT/ SERIAL LABEL LOCATION

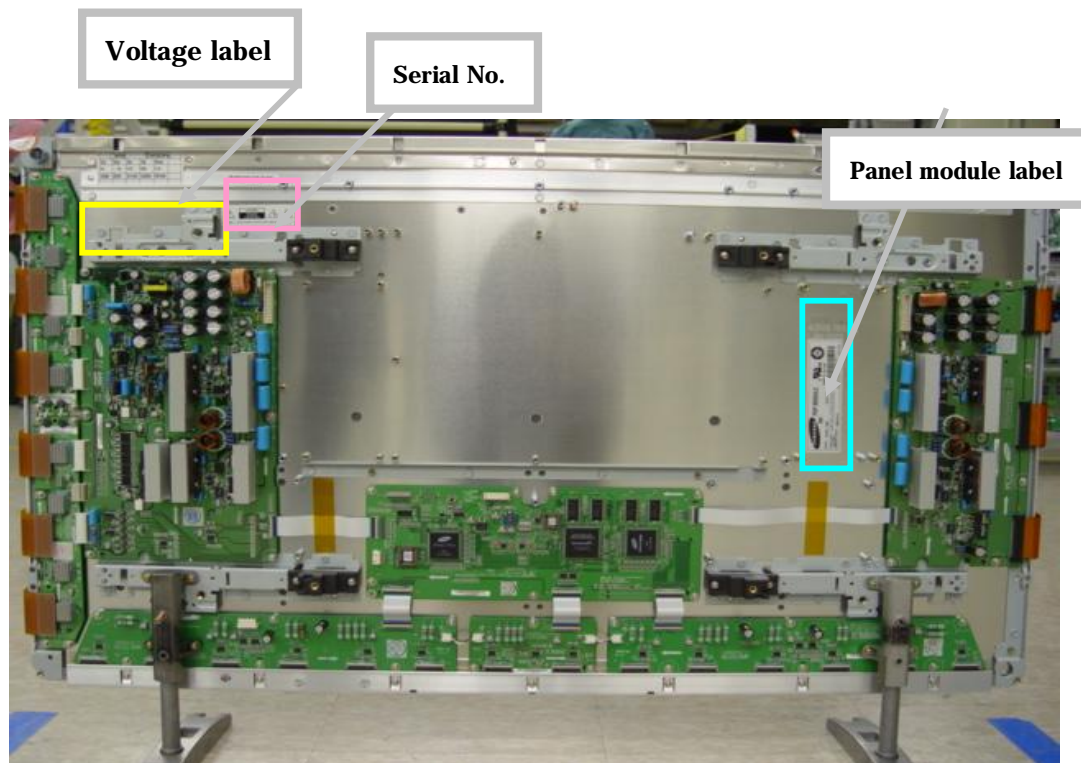

4. OPERATION CHECKING AFTER RECTIFICATION

4-1 Flow chart

* A/S Check Point *

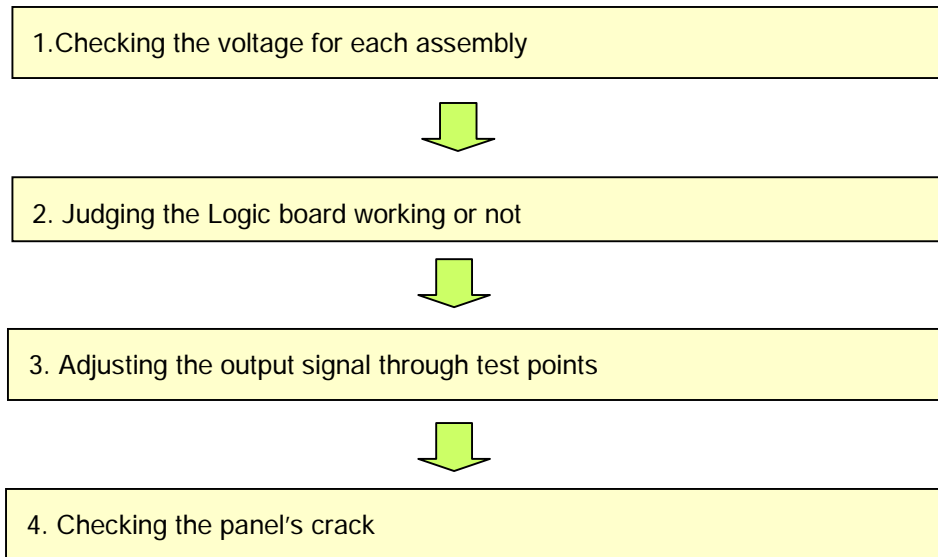

4-1-1 No voltage output

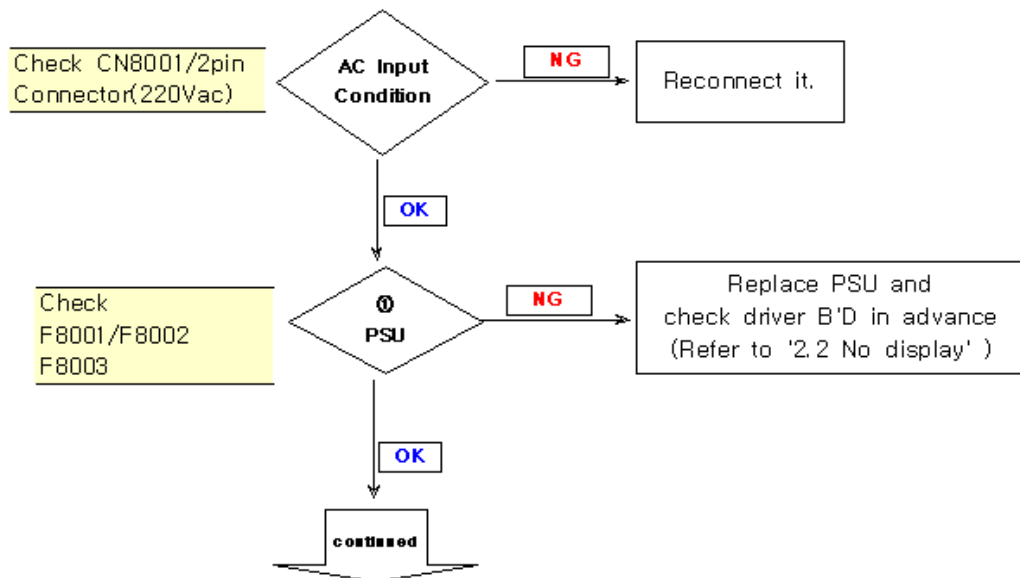

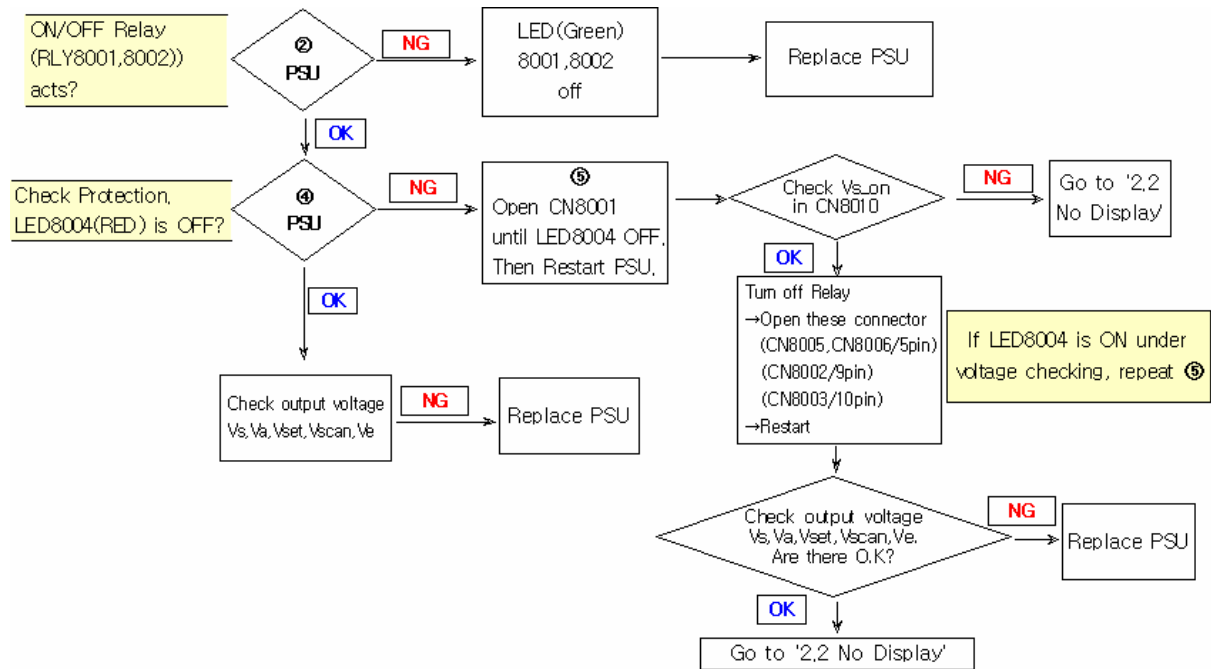

4-1-2 NO display (operating Voltage but an image doesn't exist on Screen)

⇒ No Display is related with Y-MAIN, X-MAIN, Logic Main and so on.

This page shows you how to check the boards, and the following pages show you how to find the defective board.

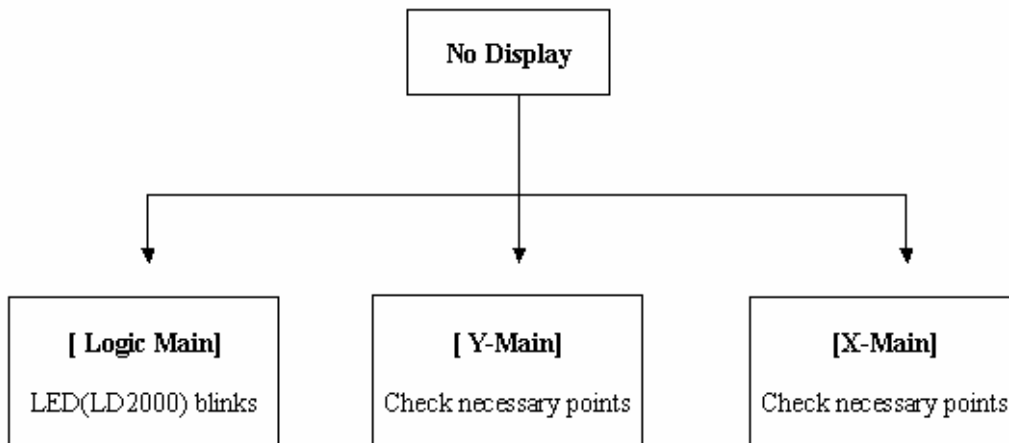

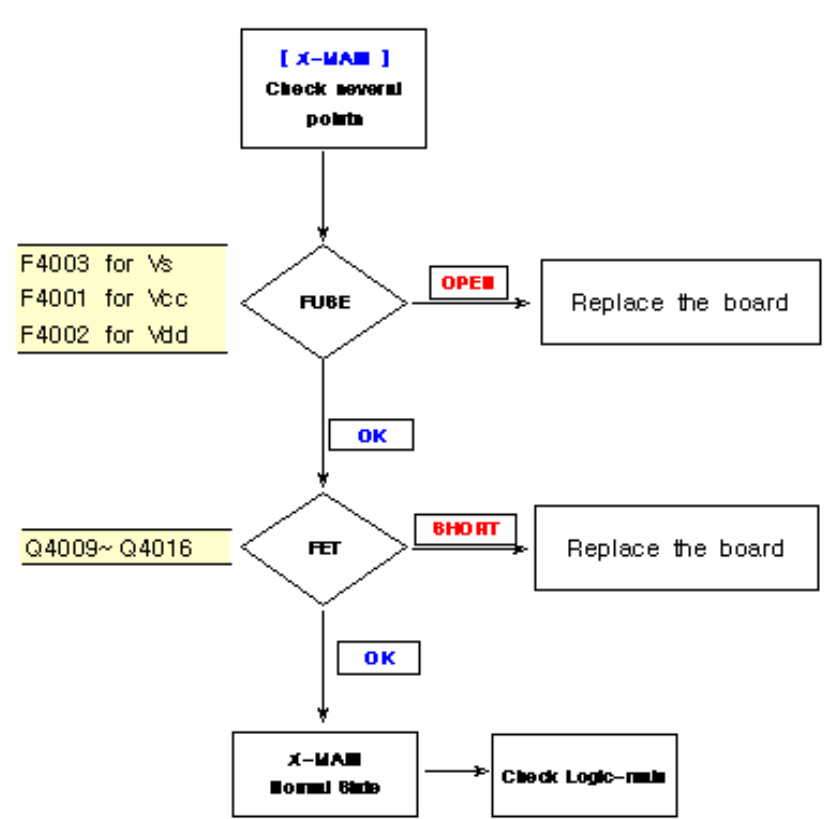
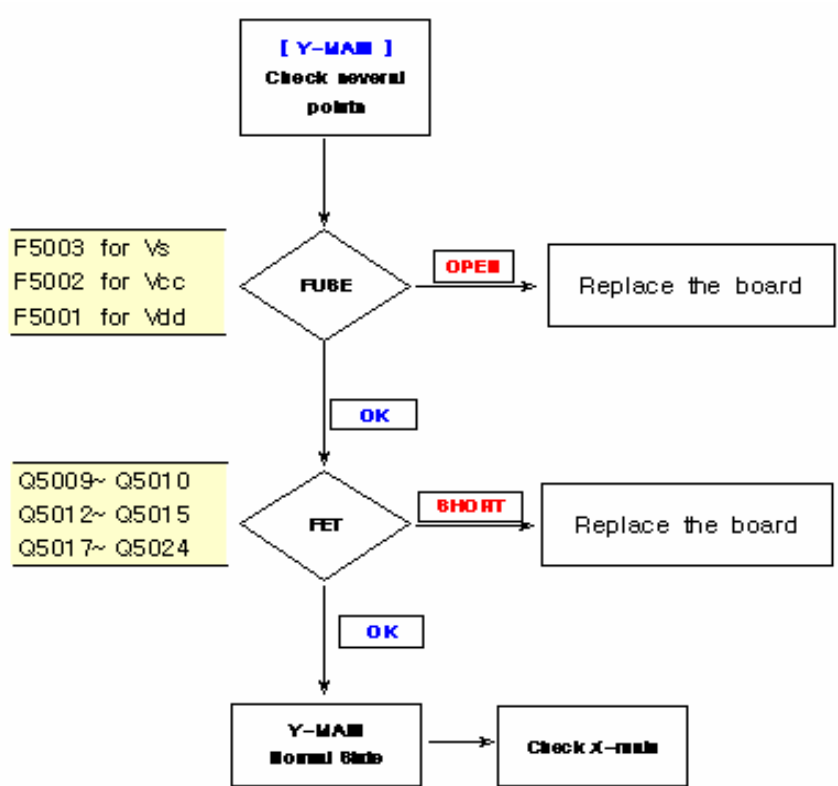

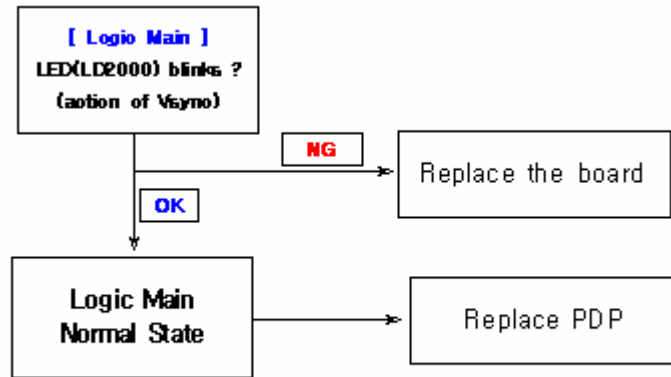

4-1-3 Abnormal Display (Abnormal Image is on Screen. (except abnormality in Sustain or Address))

⇒ Abnormal Display is related with Y-MAIN, X-MAIN, Logic Main and so on.

This page shows you how to check the boards, and the following pages show you how to find the defective board.

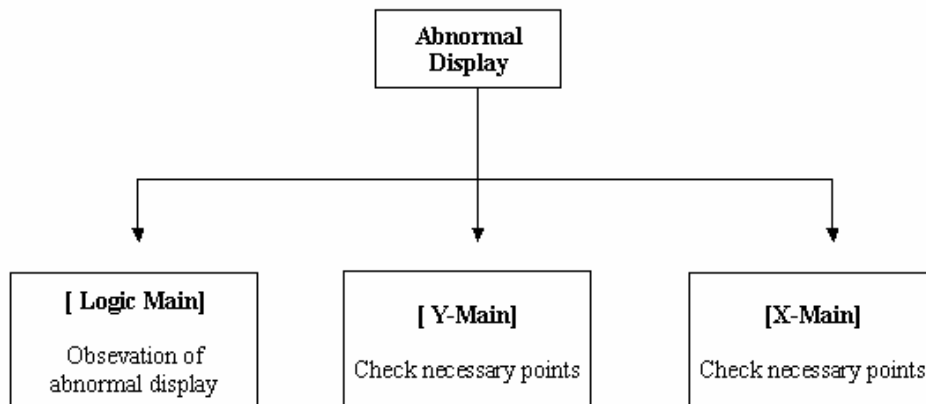

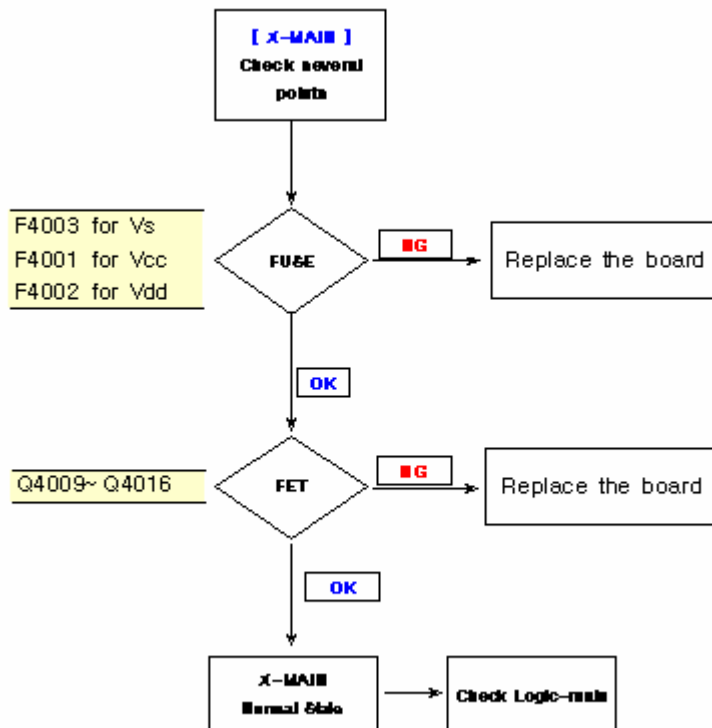
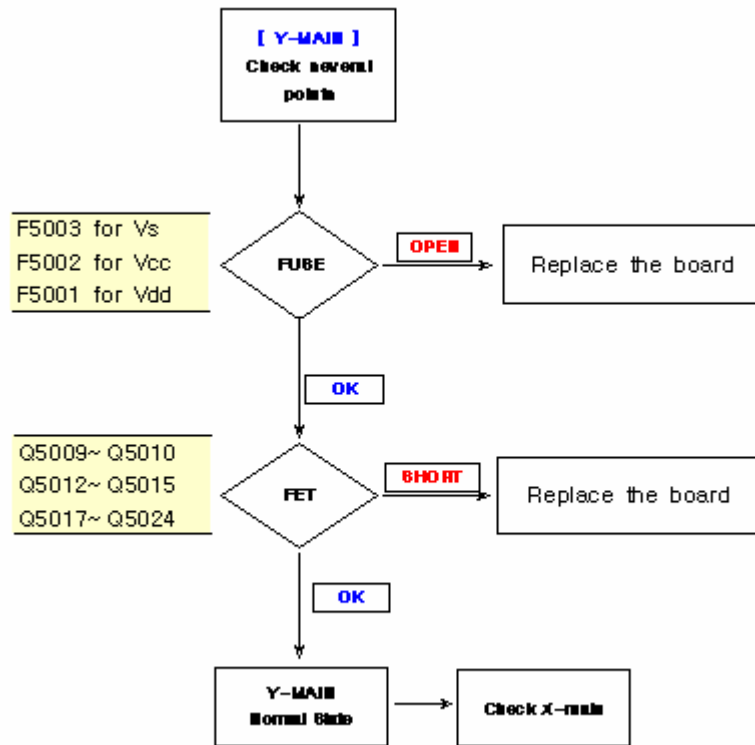

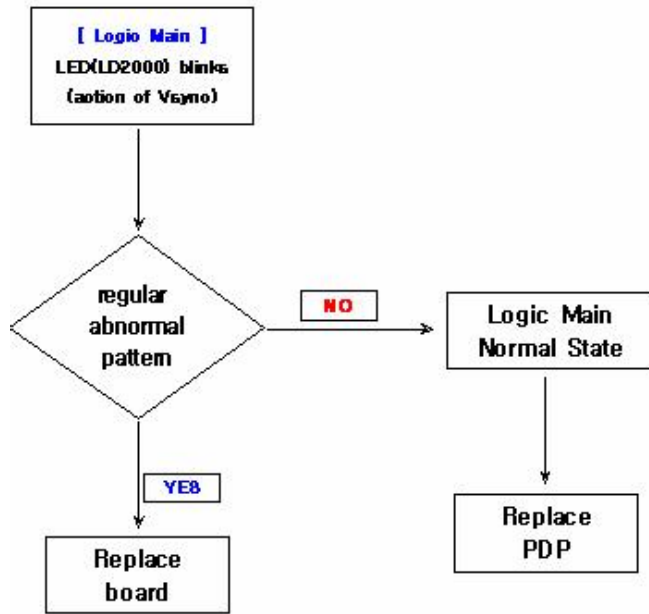

4-1-4 Sustain Open (some horizontal lines don't exist on screen)

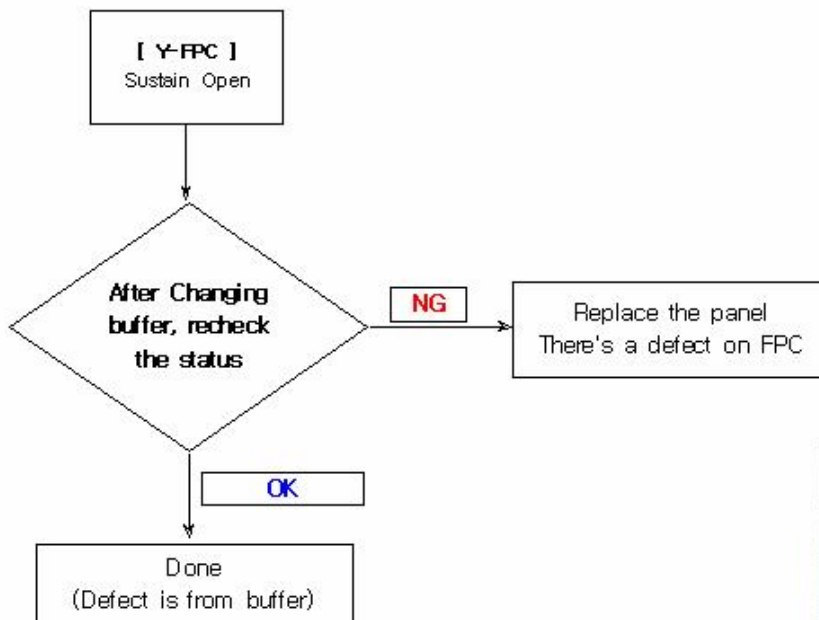

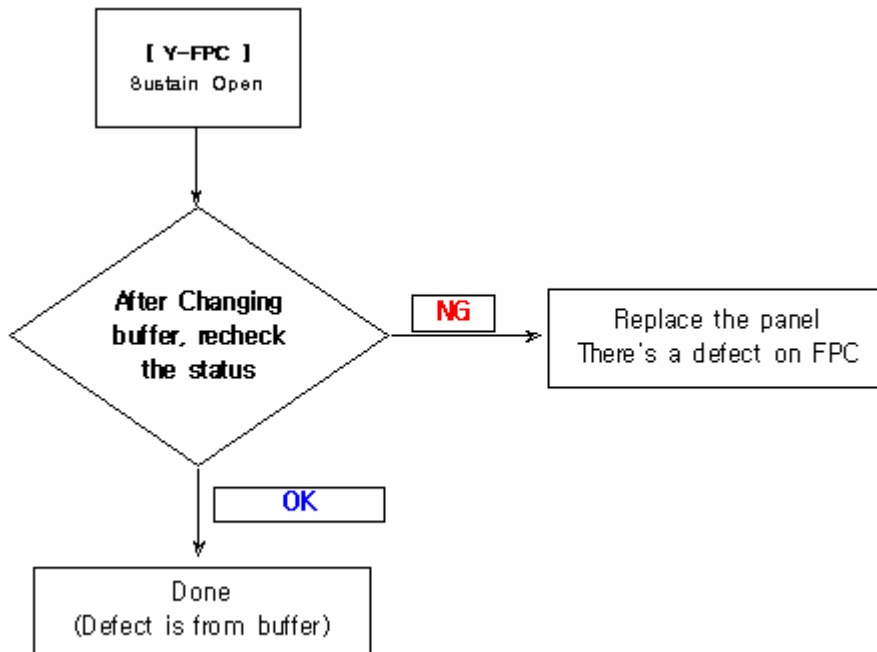
4-1-5 Sustain Short (some horizontal lines appear to be linked on Video)**4-1-6 Address Open** (some vertical lines don't exist on screen)

⇒ Address Open is related with Logic Main, Logic Buffer, FFC, TCP and so on.

This page shows you how to check the boards, and the following pages show you how to find the defective board.

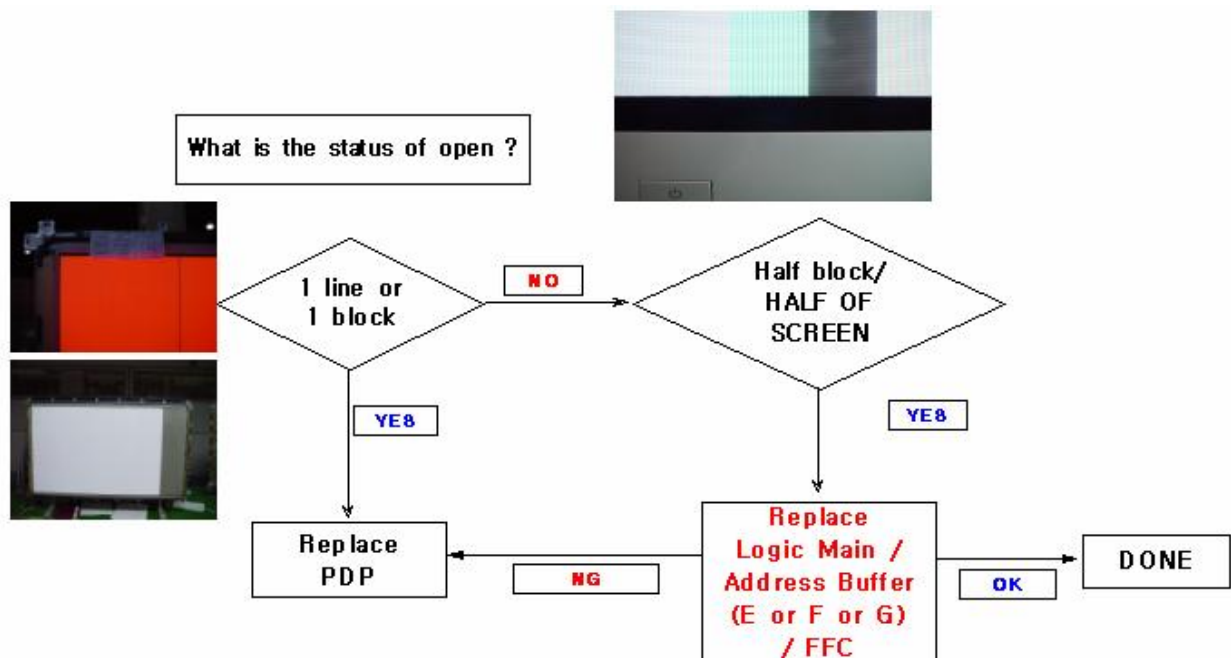
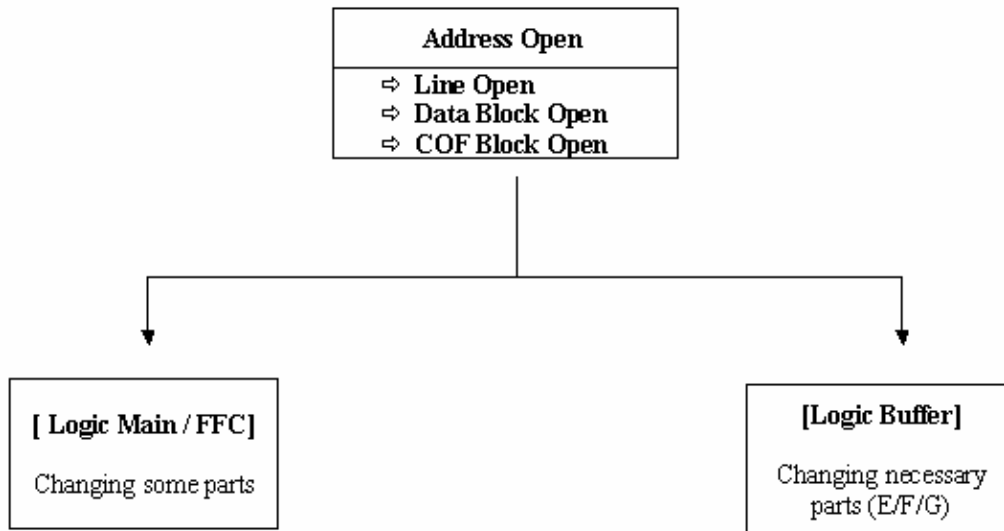

4-1-7 Address Short (some vertical lines appear to be linked on screen)

⇒ Address Short is related with Logic Main, Logic Buffer, FFC, TCP and so on.

This page shows you how to check the boards, and the following pages show you how to find the defective board.

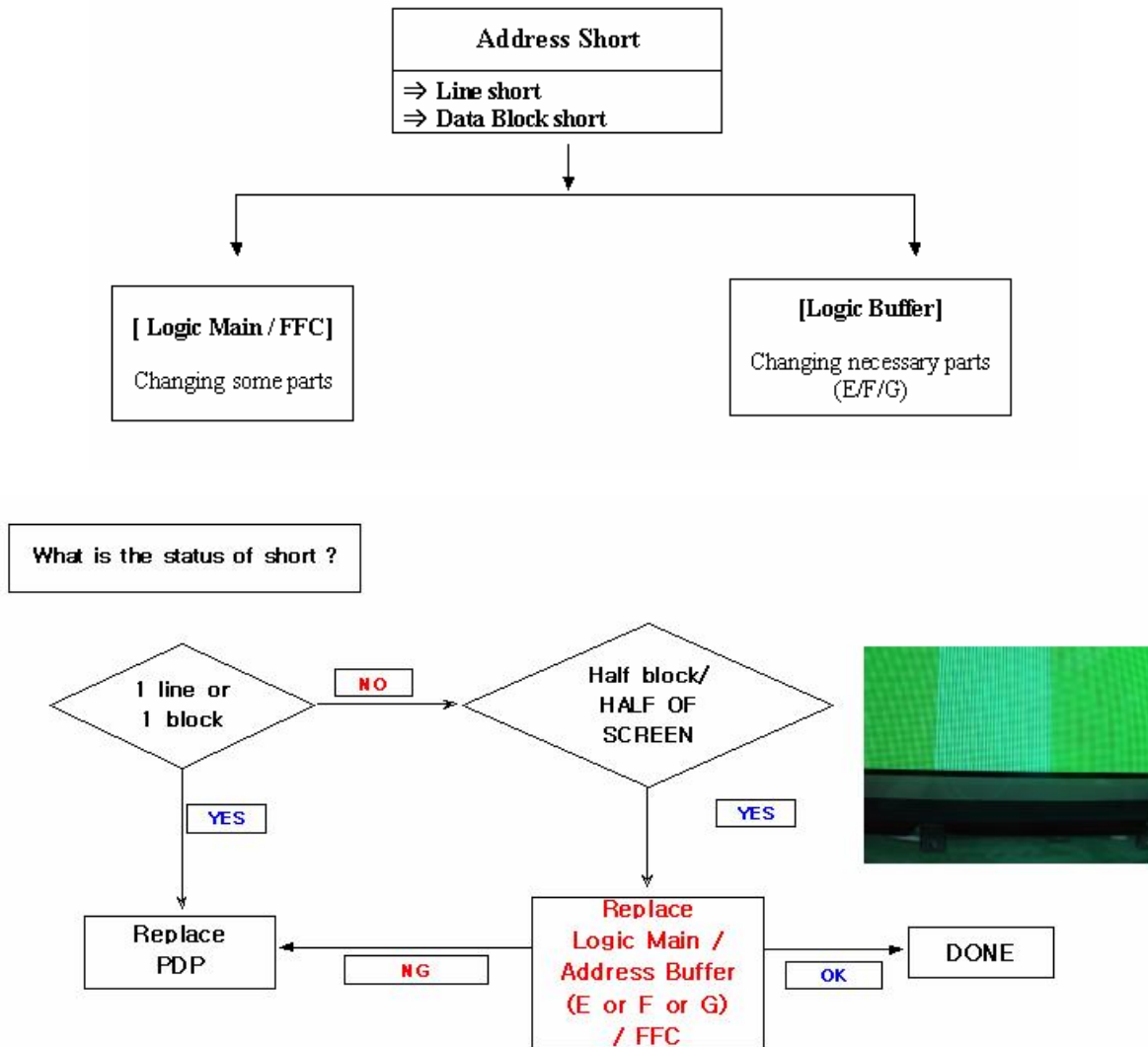

4-2 DEFECTS, SYMPTONS AND DETECTIVE PARTS

Condition Name	Description	Related Board
■ No Voltage Output	Operating Voltages don't exist.	PSU
■ No Display	Operating Voltages exist, but an Image doesn't exist on screen	Y-MAIN, X-MAIN, Logic Main, Cables
■ Abnormal Display	Abnormal Image(not open or short) is on screen.	Y-MAIN, X-MAIN, Logic Main
■ Sustain Open	some horizontal lines don't exist on screen	Scan Buffer, FPC of X / Y

<ul style="list-style-type: none"> ■ Sustain Short 	some horizontal lines appear to be linked on screen	Scan Buffer, FPC of X / Y
<ul style="list-style-type: none"> ■ Address Open 	some vertical lines don't exist on screen	Logic Main, Logic Buffer, FFC,TCP
<ul style="list-style-type: none"> ■ Address Short 	some vertical lines appear to be linked on screen	Logic Main, Logic Buffer ,FFC,TCP

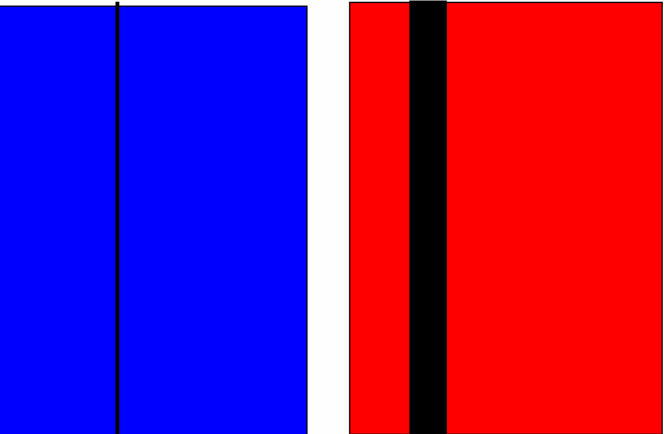
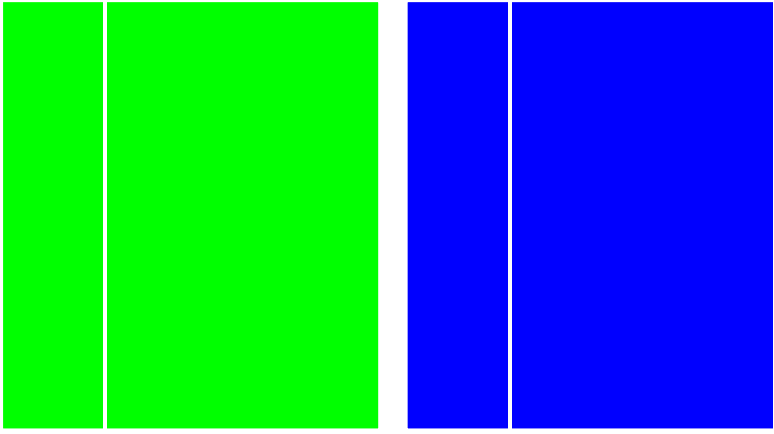
<p>◆ Defect: Address(vertical stripe) Open</p> <p>Symptom : A line or block does not light up in address electrode direction.(1 line ,block open)</p>  <p>■Cause</p> <ul style="list-style-type: none"> ① manufacturing : Panel electrode single line/ foreign material./electrostatic/ TCP defect 	<p>◆ Defect: Address(vertical stripe) Short</p> <p>■ Symptom: Another color simultaneously appears because adjacent data recognizes the single pattern signal</p>  <p>■Cause</p> <ul style="list-style-type: none"> ① manufacturing : Panel electrode short / Foreign material conductive foreign object inside TCP
---	--

- ② Parts : TCP, Board connection defect
- ③ Operation : Assembly error / Film damage

- ② Part : TCP/buffer defect lighting electrode cutting defect

◆ Defect: Address output error

- Symptom.: A defect other than address open and short Data printout signal error occurring at certain Gradation or pattern

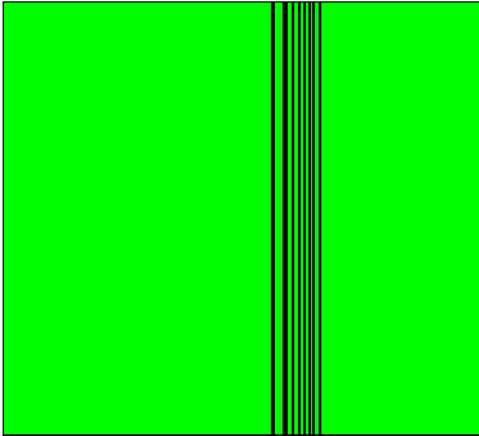

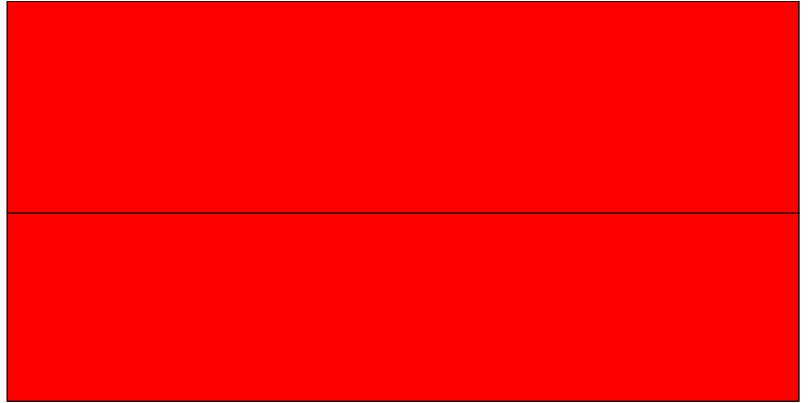

◆ Defect: Sustain(horizontal stripe) Open

- Symptom : One or more line do not light up in Sustain direction

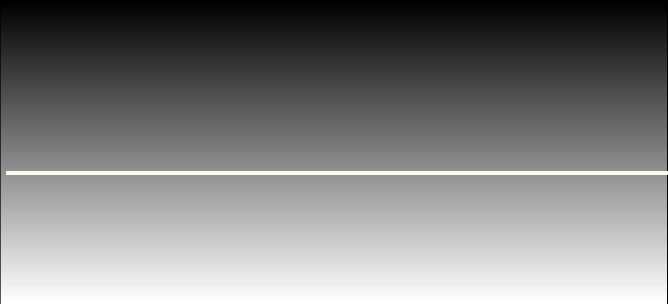

- Cause : ① manufacturing : .Panel bus electrode single line
FPC pressure defect
- ② Parts : FPC/board/connection disconnection
- ③ operation : assembly error.

<p>◆ Defect: Sustain(horizontal stripe) Short</p>	<p>◆ Defect: Dielectric material layer damage</p>
<p>■ Symptom : Combined or adjacent lines are short in sustain direction. The line appear brighter than other at Ramp gradation pattern or low gradation patter</p> 	<p>■ Symptom: Burn caused by the damage of address bus dielectric layer appears in the panel discharge/non discharge area. sustain also open/short occurs by the damage of address sustain printout</p>  <p><Add Block and Line Open></p>

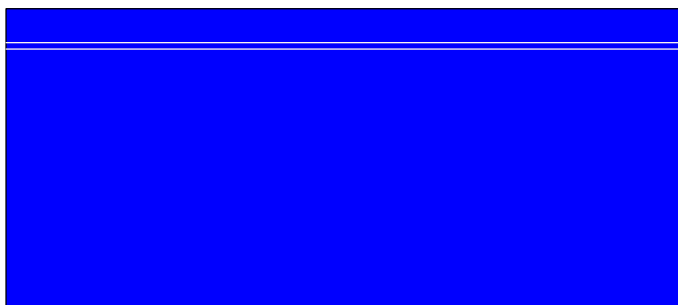

■Cause

- ① manufacturing : Panel electrode short/Foreign material.
- ② Parts : Board/ connector/pin error
- ③ Operation : connector / assembling error

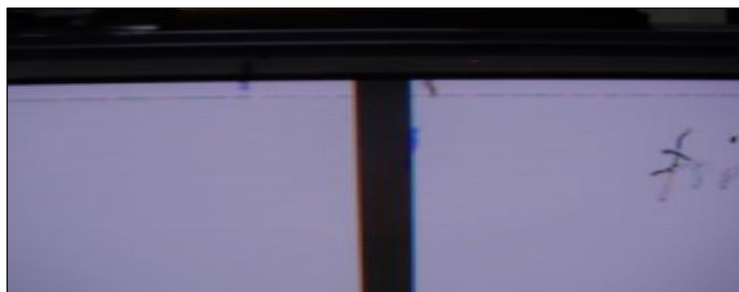

<Add and Sustain Open>

- Cause : layer uneven / abnormal voltage / foreign material repair failed

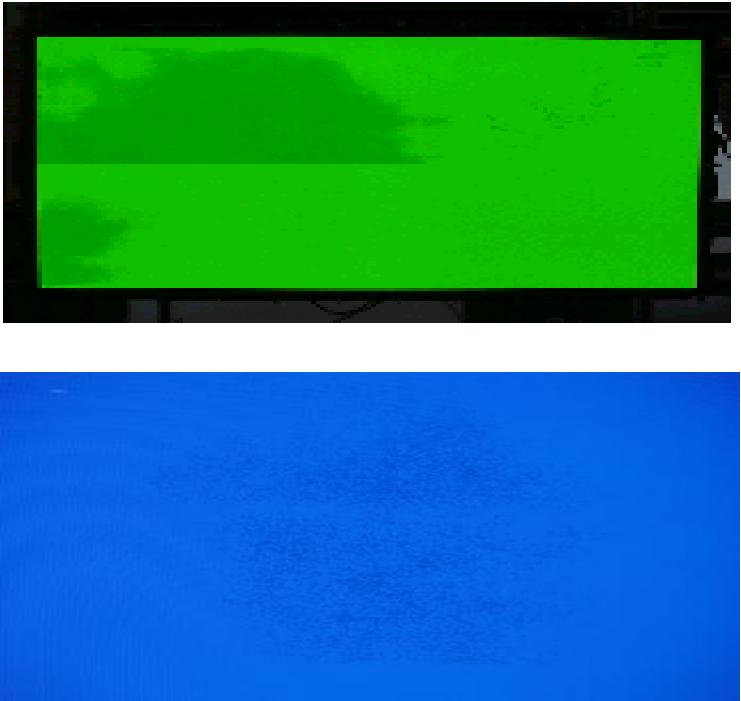
<p>◆ Defect: F/White low discharge</p>	<p>◆ Defect: Weak discharge</p>
<p>■Symptom : Low discharge caused by unstable cells occurring at full white pattern if high (60 degree) or normal temperature.</p> 	<p>■Symptom : Normal discharge but cells appear darker due to weak light emission occurring mainly at low (5 degree) Full white/Red/Green/Blue pattern or gradation pattern</p> 
<p>■ Cause</p> <ul style="list-style-type: none"> ① Panel : MgO source / dielectric thickness cell pitch/phosphor ② Circuit : drive waveform/ voltage condition 	<p>■ Cause</p> <ul style="list-style-type: none"> ① Panel : MgO deposition count and thickness / aging condition ② Circuit : drive waveform/ voltage condition

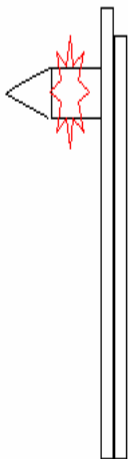
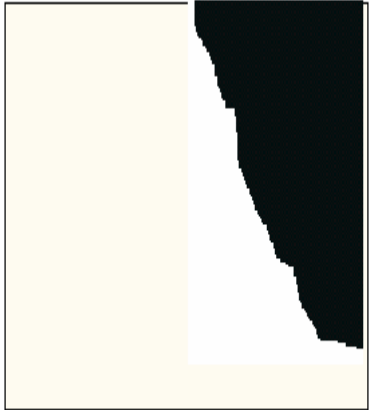
◆ Defect : panel damage	◆ Defect: Exhaust pipe damage
<ul style="list-style-type: none"> ■ Symptom : Panel crack or break. No image appears in some cause depending on the damaged parts and damage level. 	<ul style="list-style-type: none"> ■ Symptom. : Crack in break if exhaust pipe an image is partially lacking or the panel noise occurs depending on the damaged parts and with the passage of time <div style="display: flex; justify-content: space-around; align-items: center;">   </div>

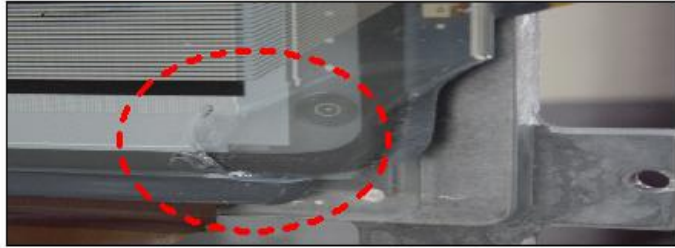
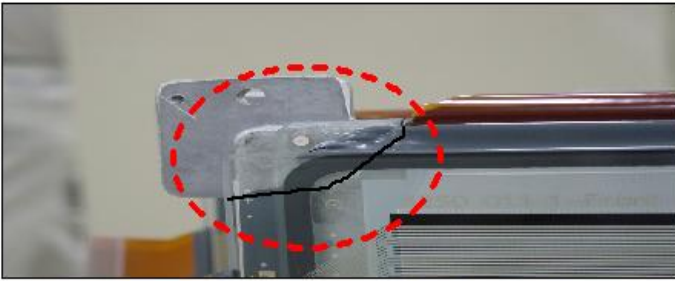

■ Cause

- ① Manufacturing : Flatness/palette pin interruption
- ② Operation : overload of panel corner / careless handling
- ③ Panel : Flatness / assembly error

- Cause : Careless panel handling

5. Disassembling / Assembling

5-1 Tools and measurement equipment

5-1-1. Tools

- 1) (+) type Screw Drivers : to screw the screws
- 2) Air Blower
- 3) Earth Ring
- 4) Small Driver : to adjust potentiometer
- 5) Dummy Discharge Resistor : 2.4kOhm/10W

5-1-2. Measuring Equipment

- 1) Oscilloscope : 500MHz sampling
- 2) Probe : 10:1

- 3) Digital Multi-meter
- 4) Signal Generator

5-2 Exploded View

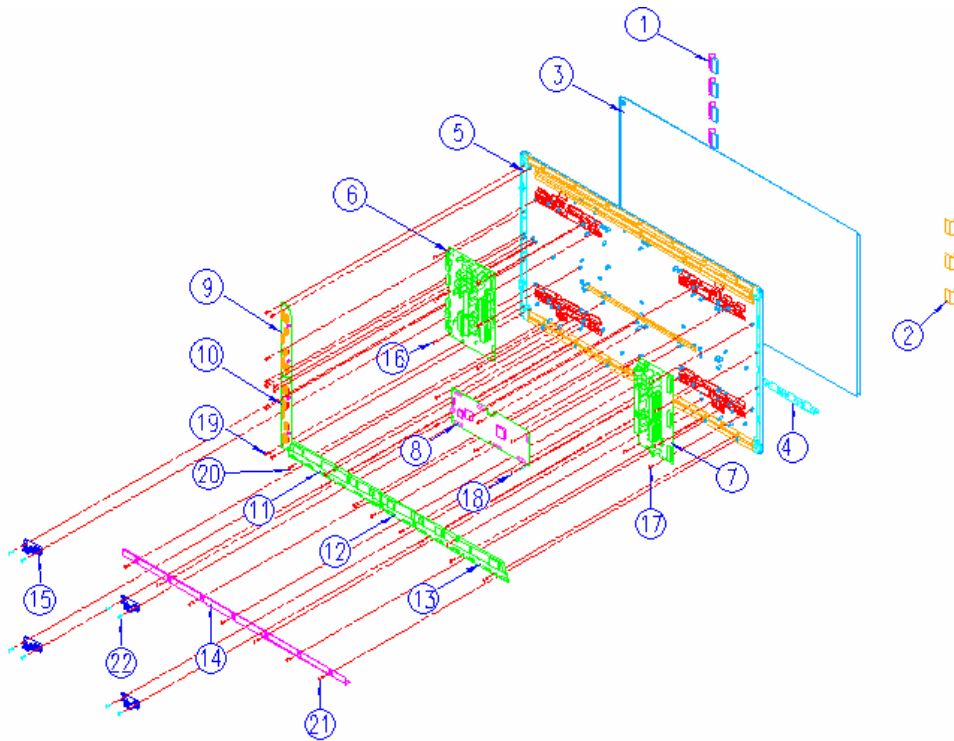

항 번	P/No	품 명	수 량	비 고
1	LJ94-00002A	Y-FPC	6	42SD,58x61mm(H*V),86LINES,0,6PITCH,80P
2	LJ99-00114A	X-FPC	3	42SD,S2,0,80,1,GOLD,FPC,X-COMMON,FPC,80P
3	DP42SD06C	Panel	1	PANEL:2,SYMMETRY,SINGLE,365X365X365,982X582
4	LJ94-00019A	TCP Film	14	TCP,52,65X55MM,0,25PITCH,STV7620M/S6PR001,UPILEX-S
5	LJ98-00105F	Assy, Chassis Base	1	LJ64-00195B,AL5052,984*584*T2,0
6	LJ92-00944B	Y-Drive	1	42SD V3,1,LJ41-02016A,-,SDI,Y MAIN,310*190*T1,6,TCP
7	LJ92-00943A	X-Drive	1	42SD V3,LJ41-02015A,SEC,SDI,X MAIN,310*140*T1,6
8	LJ92-00975B	Logic-Main	1	42SD V3,1,LJ41-01968A,FGL,SDI,L/MAIN,320*120*T1,6
9	LJ92-00796A	Y-Buffer(UP)	1	S3,0,LJ41-02059A,-,SDI,Y BUFFER UP,253*45*T1,6,V3
10	LJ92-00797A	Y-Buffer(Lower)	1	S3,0,LJ41-02059A,-,SDI,Y BUFFER LO,253*45*T1,6,V3
11	LJ92-00811A	Logic-Buffer(E)	1	42SD,LJ41-01709A,-,SDI,E BUFFER,372*60*T1,6,V3 TCP
12	LJ92-00812A	Logic-Buffer(F)	1	42SD,LJ41-01710A,-,SDI,F BUFFER,123*60*T1,6,V3 TCP
13	LJ92-00813A	Logic-Buffer(G)	1	42SD,LJ41-01711A,-,SDI,G BUFFER,372*60*T1,6,V3TCP
14	LJ98-00120A	TCP Cover Plate	1	LJ63-01613A,LJ02-02061A,LJ02-02062A
15	LJ60-00119A	Spacer Mount	4	42SD V3,1, ABS,L67,5,BLK,T3,W23, FOR_SONY
16	6006-001196	Screw	7	WSP, PH, +,M3,L10, NI FLT, SWRCH10A
17	6006-001196	Screw	8	WSP, PH, +,M3,L10, NI FLT, SWRCH10A
18	6006-001196	Screw	7	WSP, PH, +,M3,L10, NI FLT, SWRCH10A
19	6006-001196	Screw	10	WSP, PH, +,M3,L10, NI FLT, SWRCH10A
20	6006-001196	Screw	15	WSP, PH, +,M3,L10, NI FLT, SWRCH10A
21	6006-001196	Screw	7	WSP, PH, +,M3,L10, NI FLT, SWRCH10A
22	6006-001200	Screw	8	WSP, PH, +,M4,L12, NI FLT, SWRCH18A

5-3 Disassembling & Re-assembling

5-3-1 Disassembling & Re-assembling of FPC (Flexible Printed Circuit) and Y-Buffer(Upper and Lower)

1. Removal procedures

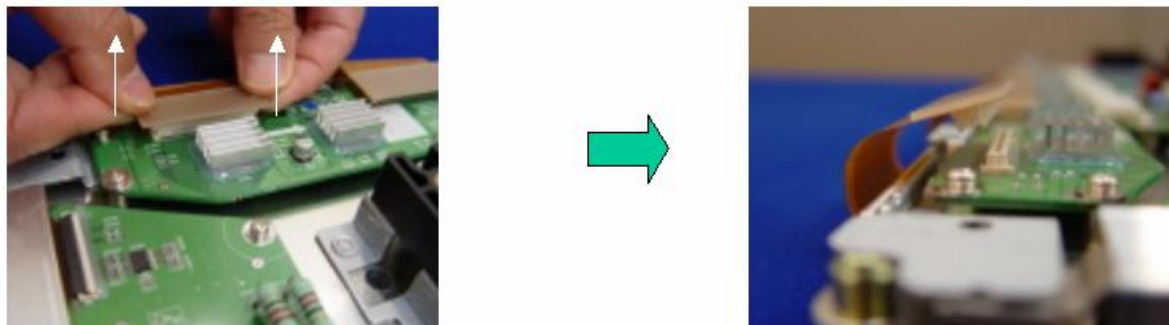

1) Full out the FPC from Connector by holding the lead of the FPC with hands.

2. Assembling Procedures

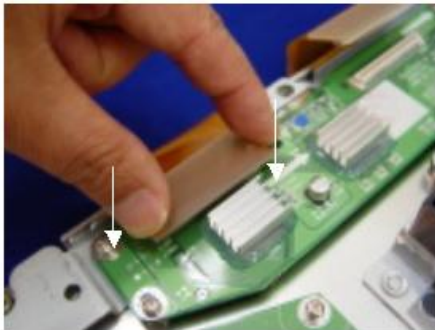

1) Push the lead of FPC with same strength until to be connected completely.

* Notice : Be careful do not get a damage on the connector pin during connecting by mistake.

5-3-2 Assembling & Disassembling of Flat Cable Connector of X-Main Board

1. Disassembling Procedure

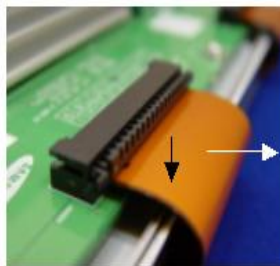

1) Pull out the clamp of connector.

2) Pull Flat cable out press down lightly.

3) Turn the Flat cable reversely.

2. Assembling Procedure

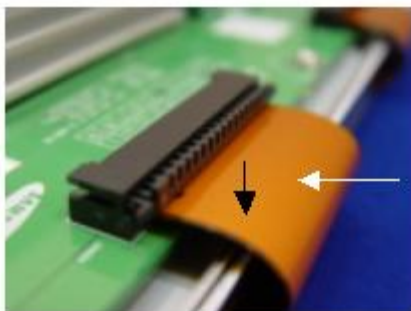

- 1) Put the Flat cable into the connector press down lightly until locking sound ("Dack") comes out.

5-3-3 Assembling & Disassembling the FFC and TCP from Connector

1. Disassembling of TCP

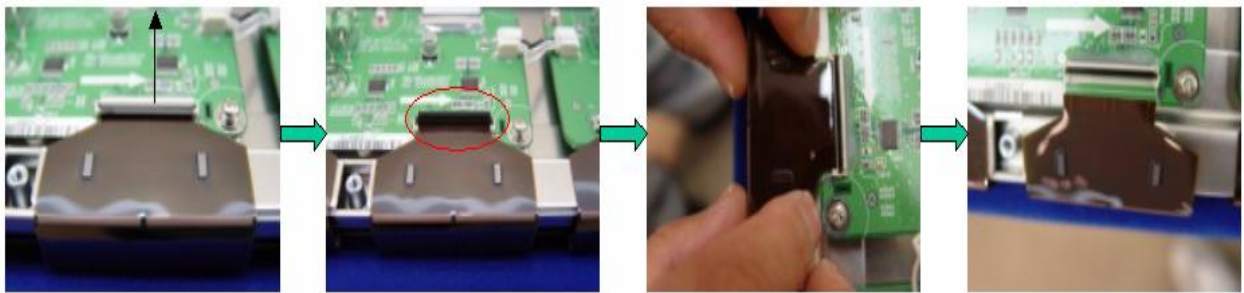

- 1) Open the clamp carefully.
- 2) Pull the TCP out from Connector.

2. Assembling of TCP

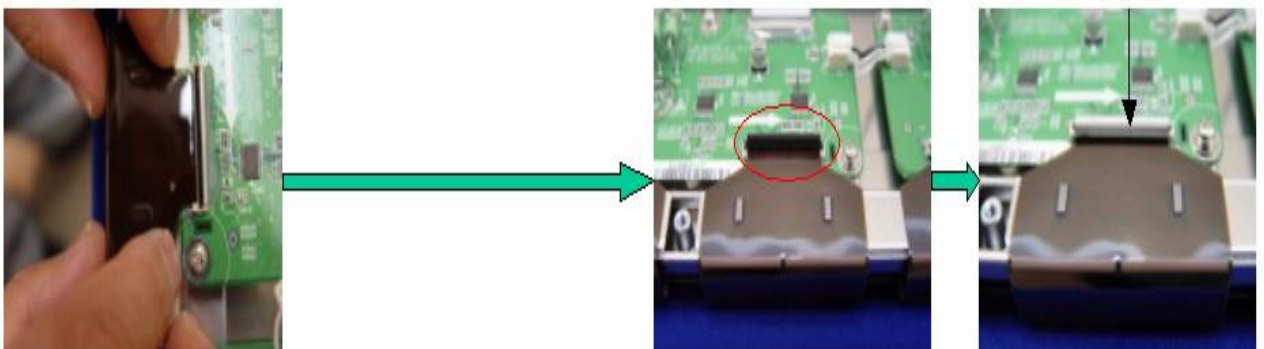

- 1) Put the TCP into the Connector carefully
- 2) Close the clamp completely.
(The sound (" Dack") comes out.)

* Notice : TCP and Connector was connected surely.

* Notice :

- 1) Checking whether the foreign material is on the Connector inside before assembling of TCP.

2) Be careful do not get a damage on the board by ESD during handling of TCP.

3. Misassembling of TCP

1) The misassembling of TCP is the cause of defect.

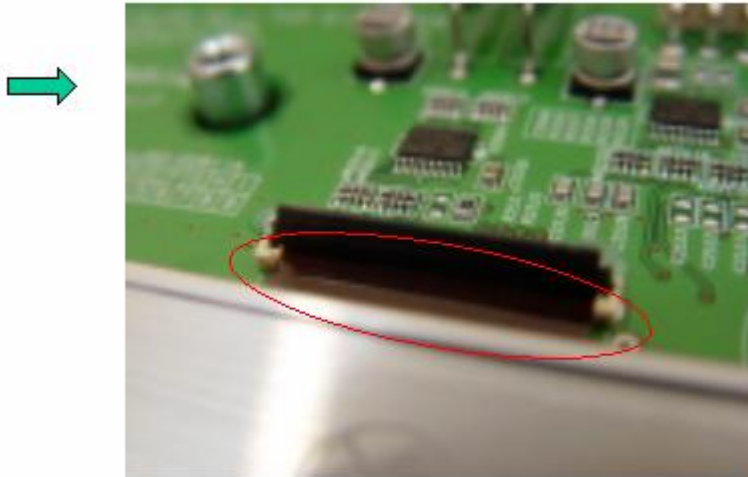

4. Checking method of misassembling of TCP



1) Disconnecting H3 from CN8006 of LBE.

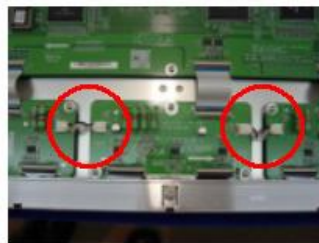

2) Whether H8 and H9 are connected.

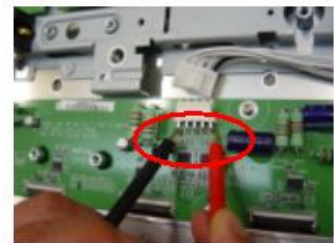

3) Checking the resistance between Pin 1 and 5.

Resistance > a few [K Ohm] : OK
 Resistance < 20 Ohm : At least ,more than 1pc of TCP is wrong.

5. Assembling & Disassembling of FFC

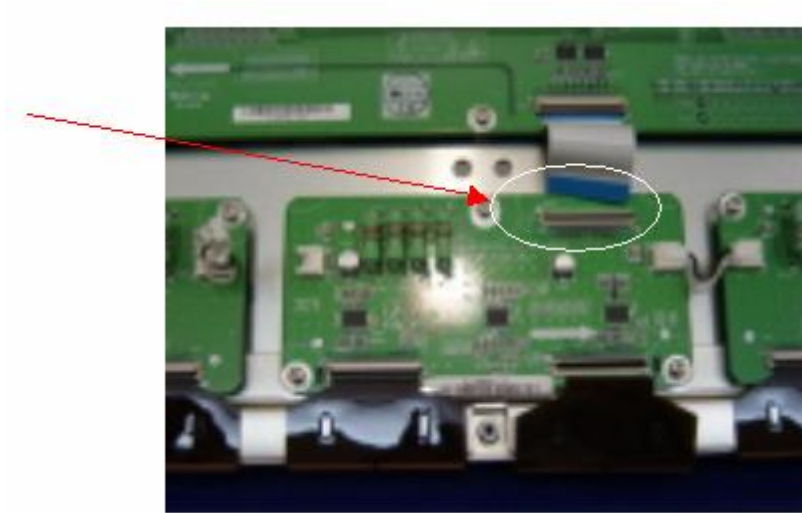

(This is the photo of the assembling of FFC)

The procedure of assembling and disassembling of FFC is the same as TCP.

5-3-4 Exchange of LBE, LBF, LBG board



(Photo 1)

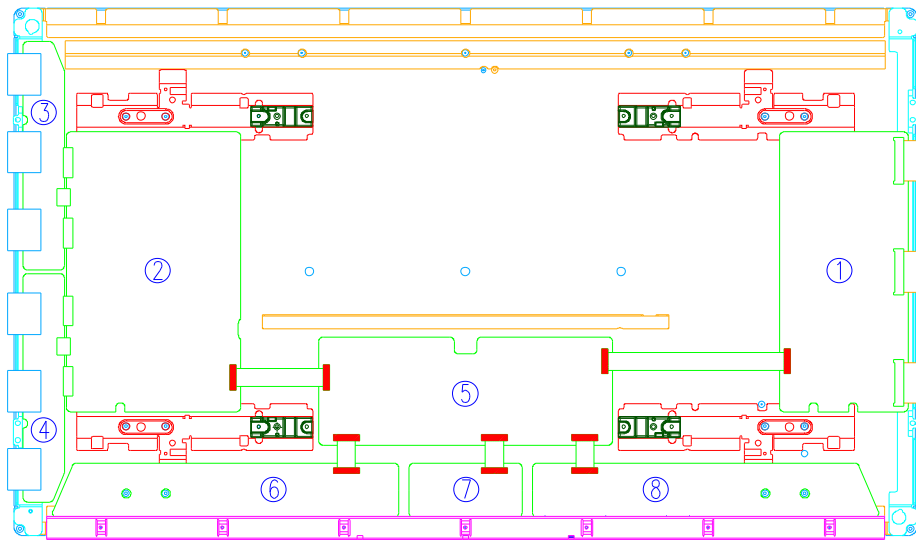

(Photo 2)

- 1) Remove the screws in order of 2-3-5-7-1-4 from heat sink and then get rid of heat sink. (Photo 1)
- 2) Remove the TPC, FFC and power cable from the connectors.
- 3) Remove all of the screws from defected board.
- 4) Remove the defected board.
- 5) Replace the new board and then screw tightly.
- 6) Get rid of the foreign material from the connector.
- 7) Connect the TCP, FFC and power cable to the connector.
- 8) Reassemble the TCP heat sink.
- 9) Screw in order of 4-1-7-6-5-3-2. (Photo 2)

If you screw too tightly, it is possible to get damage on the Driver IC of TCP.

* Logic

5-3-5 Exchange YBU, YBL and YM board

- 1) Separate all of the FPC connector of YBU (Y-Buffer upper) and YBL (Lower). (Photo 1)
- 2) Separate all of the connector of CN5001 and CN5008 from Y-Main.
- 3) Loosen all of the screws of YBU, YBL and YM.
- 4) Remove the board from chassis.
- 5) Remove the connector of CN5006 and CN5007 among YBU, YBL and YM.
- 6) Remove the YBL and YBU from Y-main.
- 7) Replace the defected board.



8) Reassemble the YBU and YBL to the Y-Main.

9) Connect the connector of CN5006 and CN5007 among YBU, YBL and YM.

10) Arrange the board on the chassis and then screw to fix.

11) Connect the FPC and YM of panel to the connector.

12) Supply the electric power to the module and then check the waveform of board.

13) Turn off the power after the waveform is adjusted.

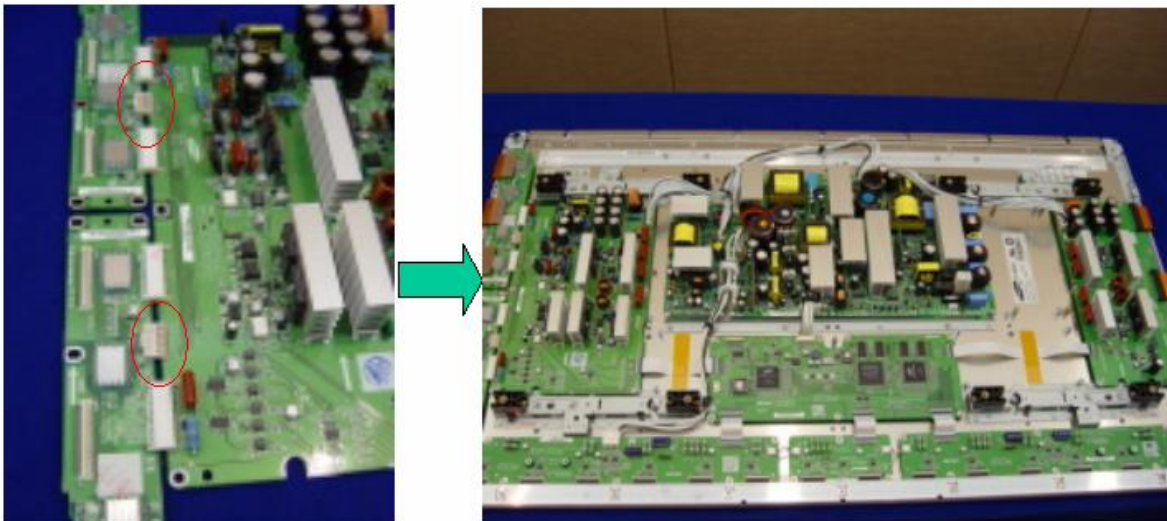

6. Operation Check after Repair Service

6-1 Check Item

	Check Item	Specification	Remarks
Module assemble check	TCP Assembling condition	Securely connected or tightened	
	Drive board		
	Y BUFFER		
	Logic & Logic Buffer		
	Harness	Securely connected	
	Material Mixing	No material mixing	

6-2 Check Procedure

- 1) Visual check as following
 - a. Assembling condition of module.
 - b. No problem on the connection of module.
 - c. The grounding and easily short-circuited parts are not damaged.
- 2) Check the Dip Switch is located module inside.
- 3) Turn on the power to PDP module, and then check that LED lights up and the SET is working well.
- 4) Check the power voltage after turn on the power, and then check the Display condition by tapping slightly the Y-FPC 2 or 3 times.
- 5) Check whether something wrong during Full White Pattern period.
- 6) If something wrong, each voltage should be set to the standard voltage by using Multi-Tester and adjusting tools.
- 7) Adjust the waveform, using Oscilloscope for the waveform adjusting point.
- 8) Check the discharge of front panel by changing the image for each pattern.

9) Check the Low-discharge, Over-discharge and panel condition by adjusting the Pattern Generator Level.

7. Operation Check

7-1 Adjustment Specification, Checking Position etc.

V3.1 TCP Ramp Waveform Inclination Adjustment (Y-Board)

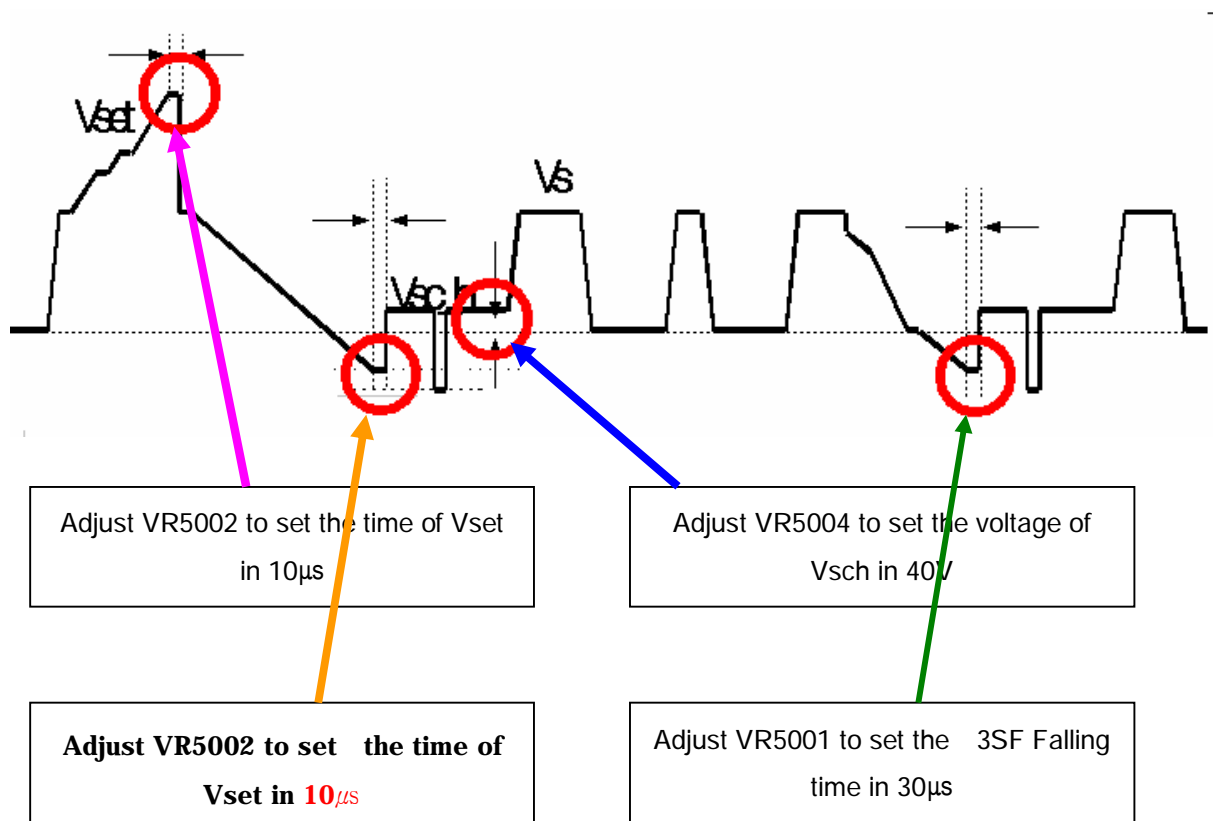

* Dip Switch Mode

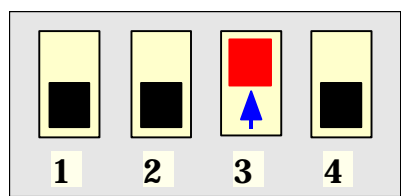

< Internal >

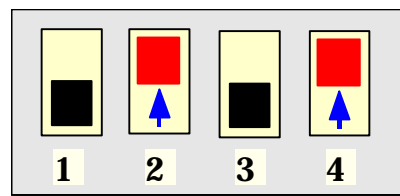

< External >

7-2 Adjusting procedure

- 1) Get Pattern to be Full White.
- 2) Adjust Vsch to 40V by using VR5004 (Vsch should be connected to "+" unit of Multimeter).
Vsch is over 95V than Vsc_I.
- 3) Check the waveform using Oscilloscope.
 - ① Triggering through V_TOGG of LOGIC Board.
 - ② Connect the OUT 4 Test Point at the center of Y_buffer to other channel, and then check the first SF operating waveform of 1TV-Field.
 - ③ Check the waveform as before by adjusting Horizontal Division.
Check the Reset waveform when the V_TOGG Level is changed.
 - ④ Set the Vset to 10us by adjusting VR5002.
GND maintenance section should be checked after the Vertical Division is readjusted to '2V or 5V'.
 - ⑤ Set the Falling maintenance time to 30us by adjusting R5003.
 - ⑥ Change the waveform position of Oscilloscope to 3SF and then set the Falling maintenance time to 30us by adjusting the VR5001.
GND maintenance section should be checked after the Vertical Division is readjusted to '2V or 5V'.

※ Special Notice

When you adjust the inclination of waveform, do check and adjustment being based on the Reset waveform of 1st Sub-field of 1st Frame and then move to 3rd Sub-field for adjusting.

8. SPARE PART LIST FOR THE PANEL

Beko Part Code	Part Definition
X53.101	PCB ASSY X MAIN ASSY (LJ92-00943A)
X53.102	PCB ASSY LOGIC-BUFFER(E) (LJ92-00811A)
X53.103	PCB ASSY LOGIC-BUFFER(F) SDI 42V3 (LJ92-00812A)
X53.104	PCB ASSY LOGIC-BUFFER(E) SDI 42V3 (LJ92-00813A)
X53.105	PCB ASSY Y-BUFFER(UP) SDI 42V3 (LJ92-00796A)
X53.106	PCB ASSY Y-BUFFER(DOWN) SDI 42V3 (LJ92-00797A)
X53.107	PCB ASSY LOGIC-BOARD SDI 42V3 (LJ92-00975E)
X53.108	PCB ASSY SMPS(PSU)SDI 42V3(LJ44-00068A)
X53.109	PCB ASSY Y-BOARD SDI 42V3 (LJ92-00944B)
X51.112	FPC 58x61mm(H*V),86LINES,0.6PITCH,80P (LJ94-00002A)
X51.113	FFC CABLE -FLAT LOGIC-XBOARD (3809-001396) 60V,105C,210MM,30P,0.5MM,UL20861
X51.115	FFC CABLE -FLAT LOGIC-YBOARD (3809-001397) 60V,105C,105MM,40P,0.5MM,UL20861
X53.116	FFC CABLE -FLAT 42V3 LOGIC-L-BUFFER (3809-001414)
X53.116	FFC CABLE -FLAT 42V3 LOGIC-L-BUFFER (3809-001414)
X53.116	FFC CABLE -FLAT 42V3 LOGIC-L-BUFFER (3809-001414)
X53.117	CABLE SMPS-LOGIC 42V3 (LJ39-00143A)
X53.118	CABLE SMPS-L.BUFFER(E) 42V3 (LJ39-00140A)
X53.119	CABLE SMPS-XBOARD 42V3 (LJ39-00179A)
X53.120	CABLE SMPS-YBOARD 42V3 (LJ39-00142A)
X51.120	CABLE L.BUFFER-L.BUFFER (LJ39-00109A)
X51.120	CABLE L.BUFFER-L.BUFFER (LJ39-00109A)

VGA-DVI DECODER

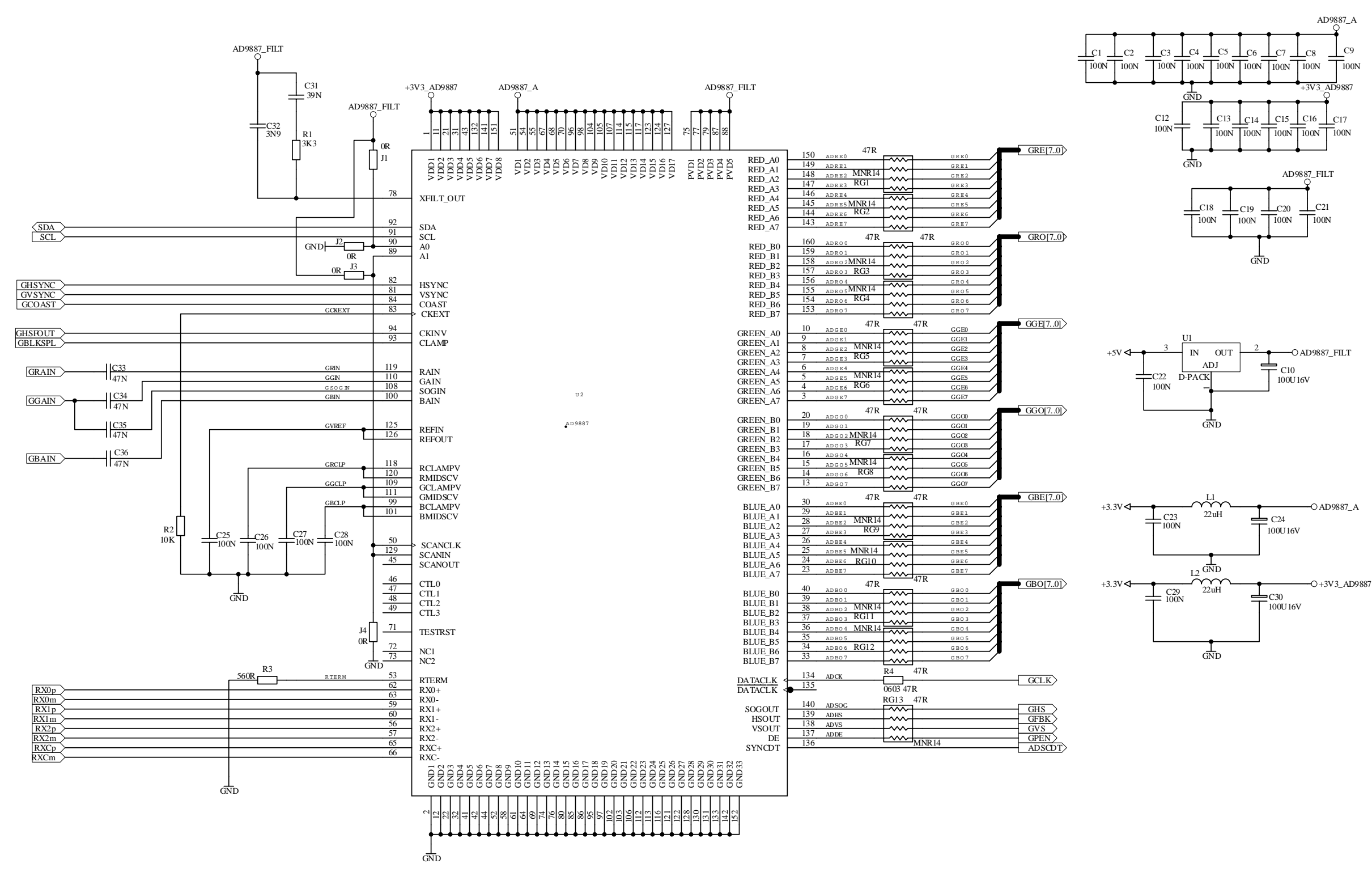

AUDIO

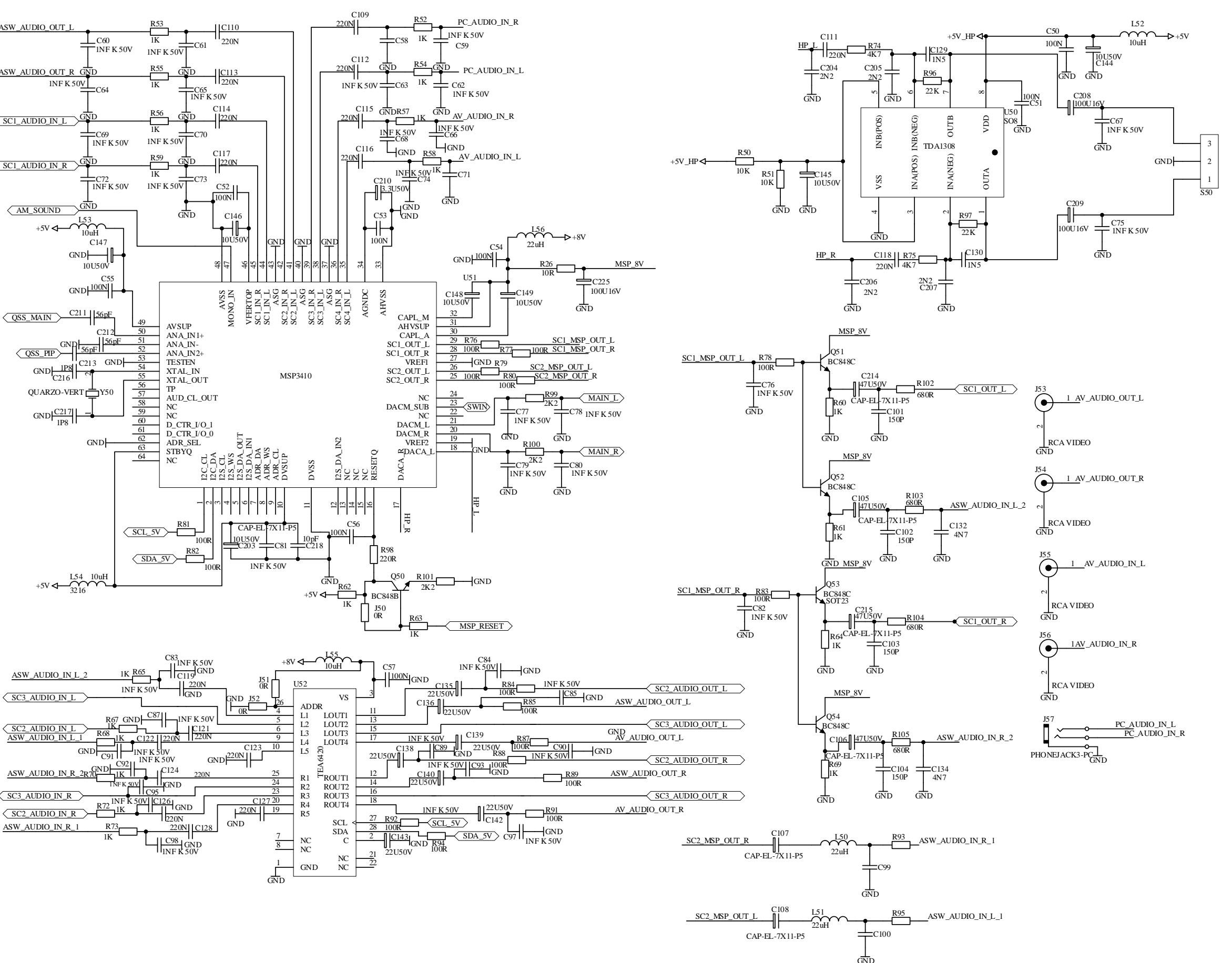

SCART I/O

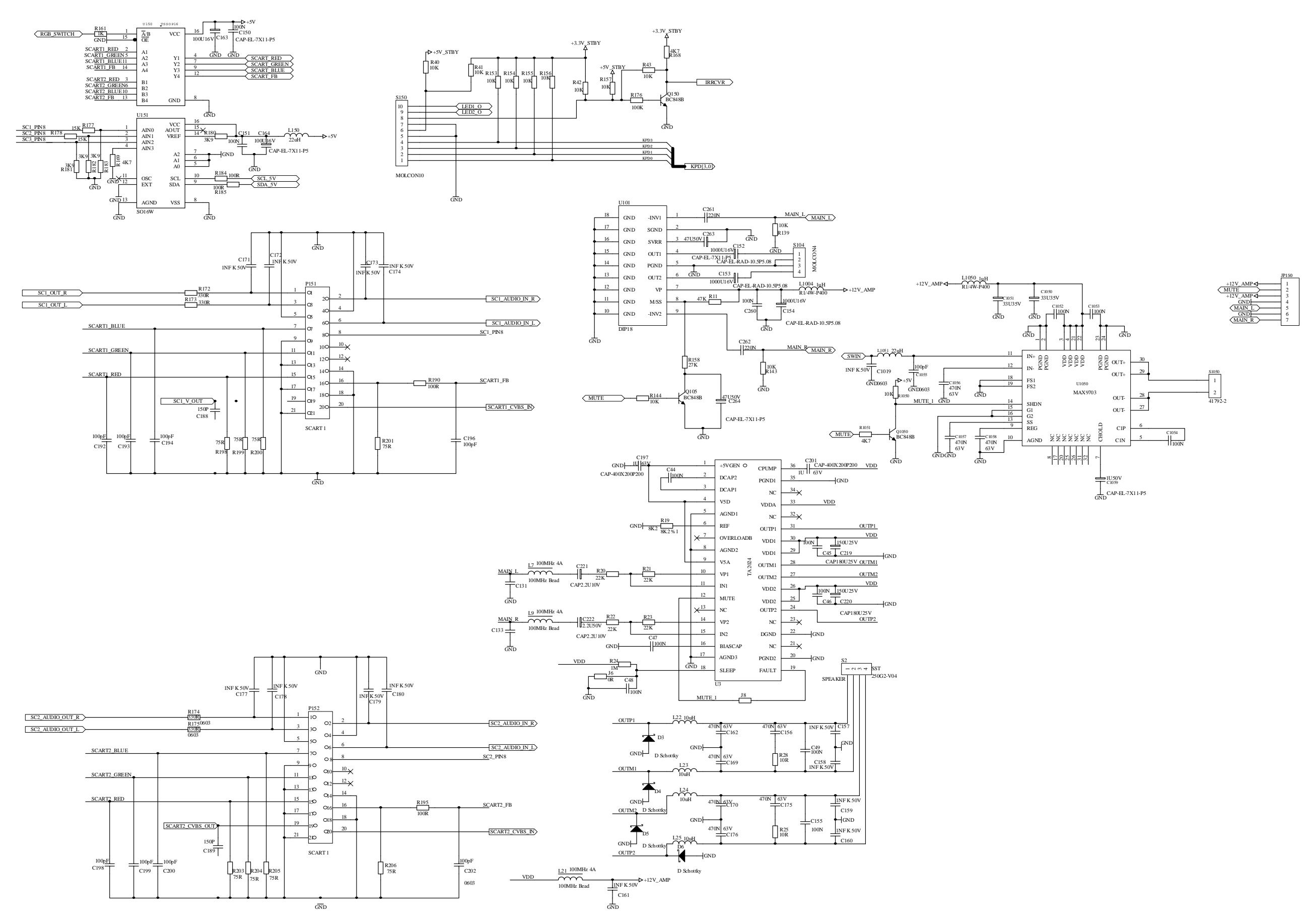

VGA-DVI I/O

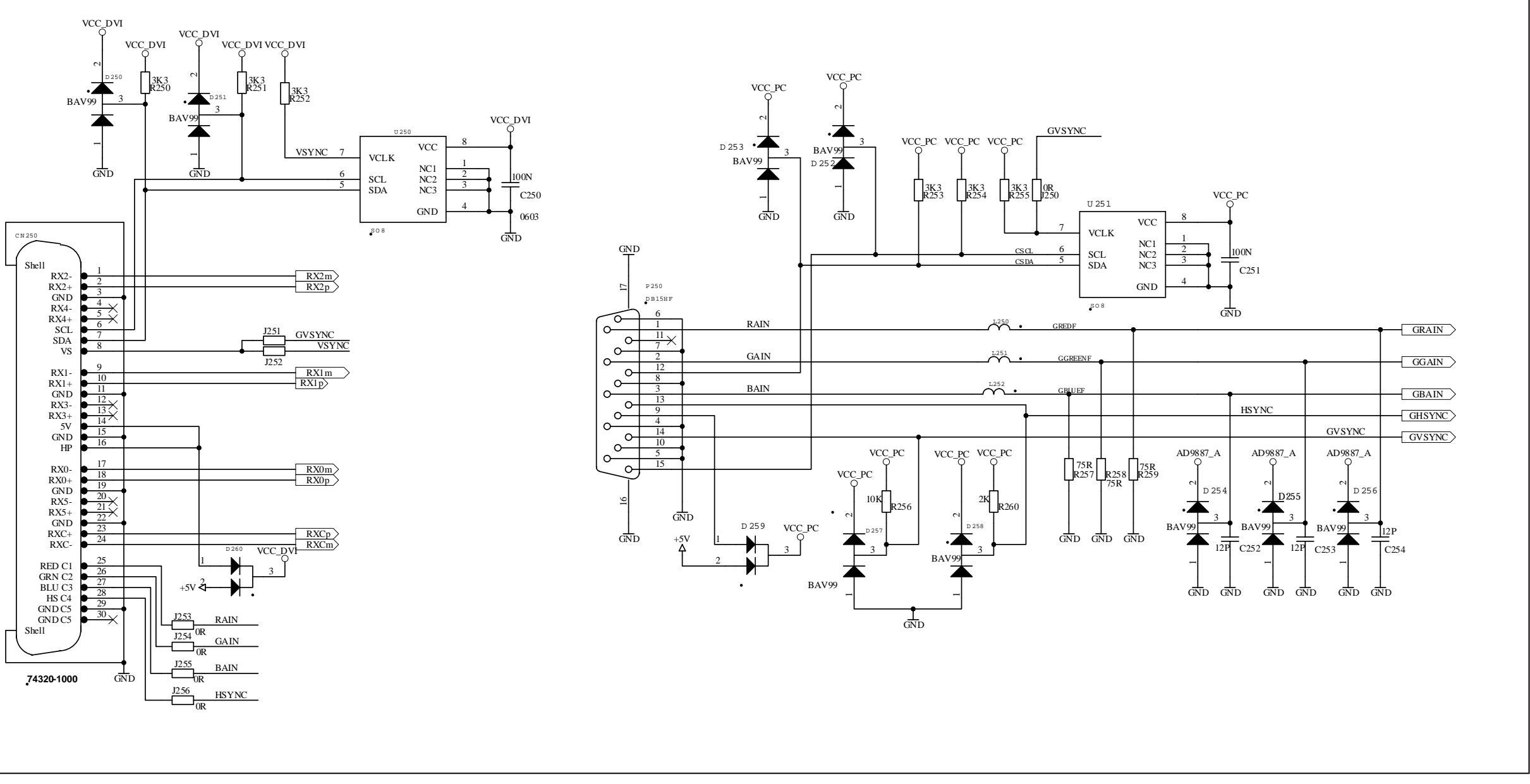

POWER

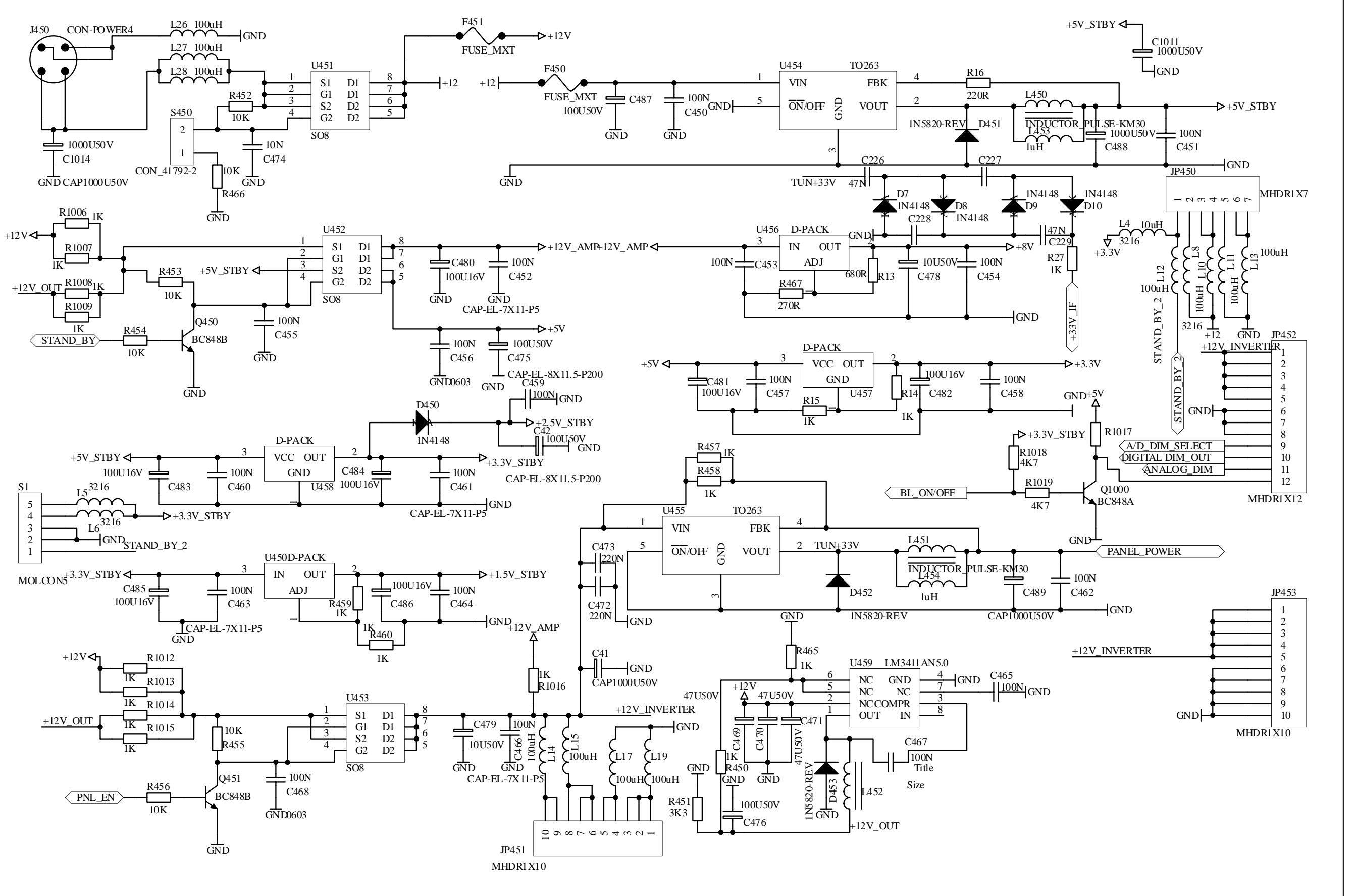

LVDS TRANSMITTER

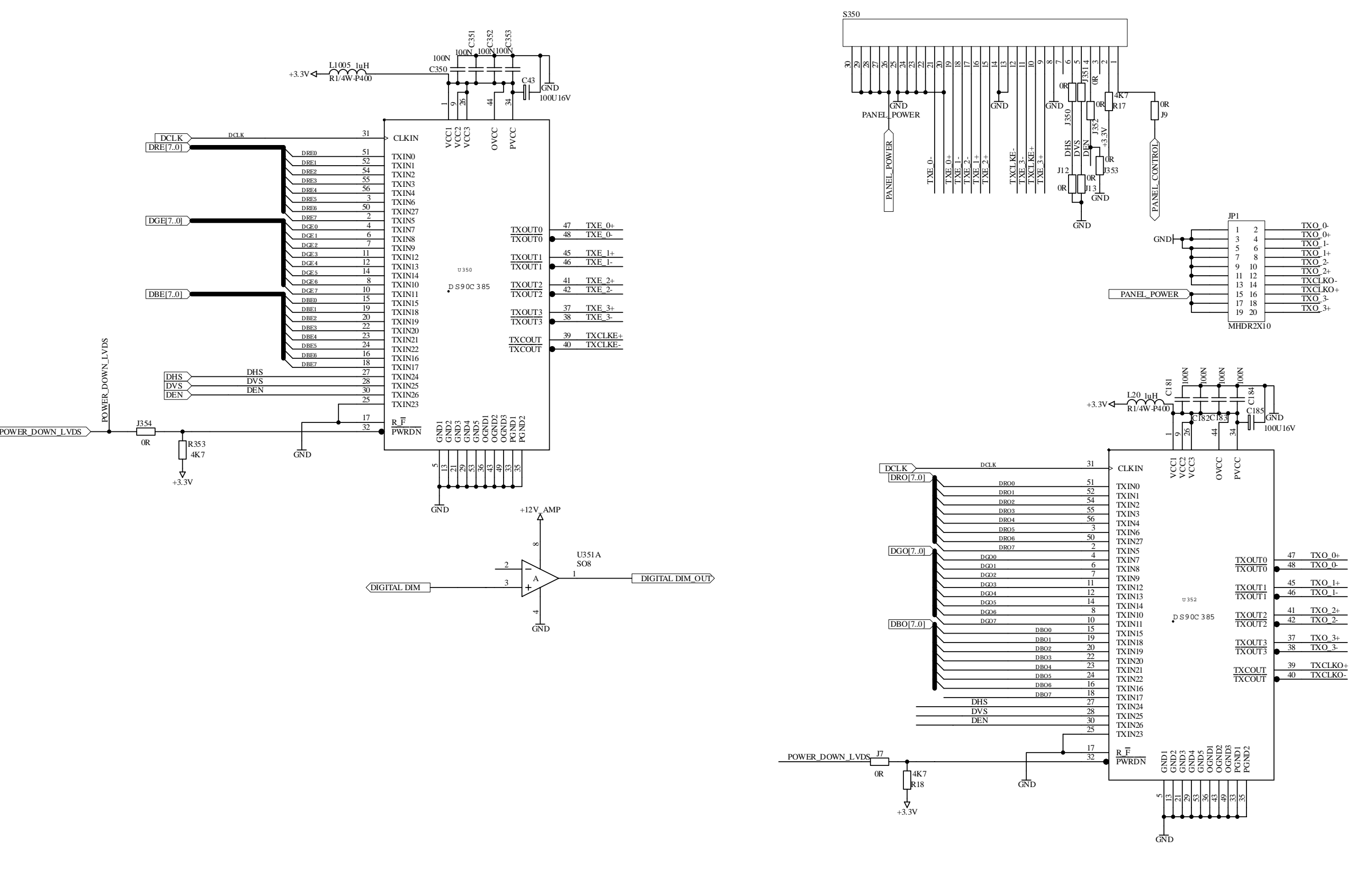

FLASH MEMORY-RESETIC

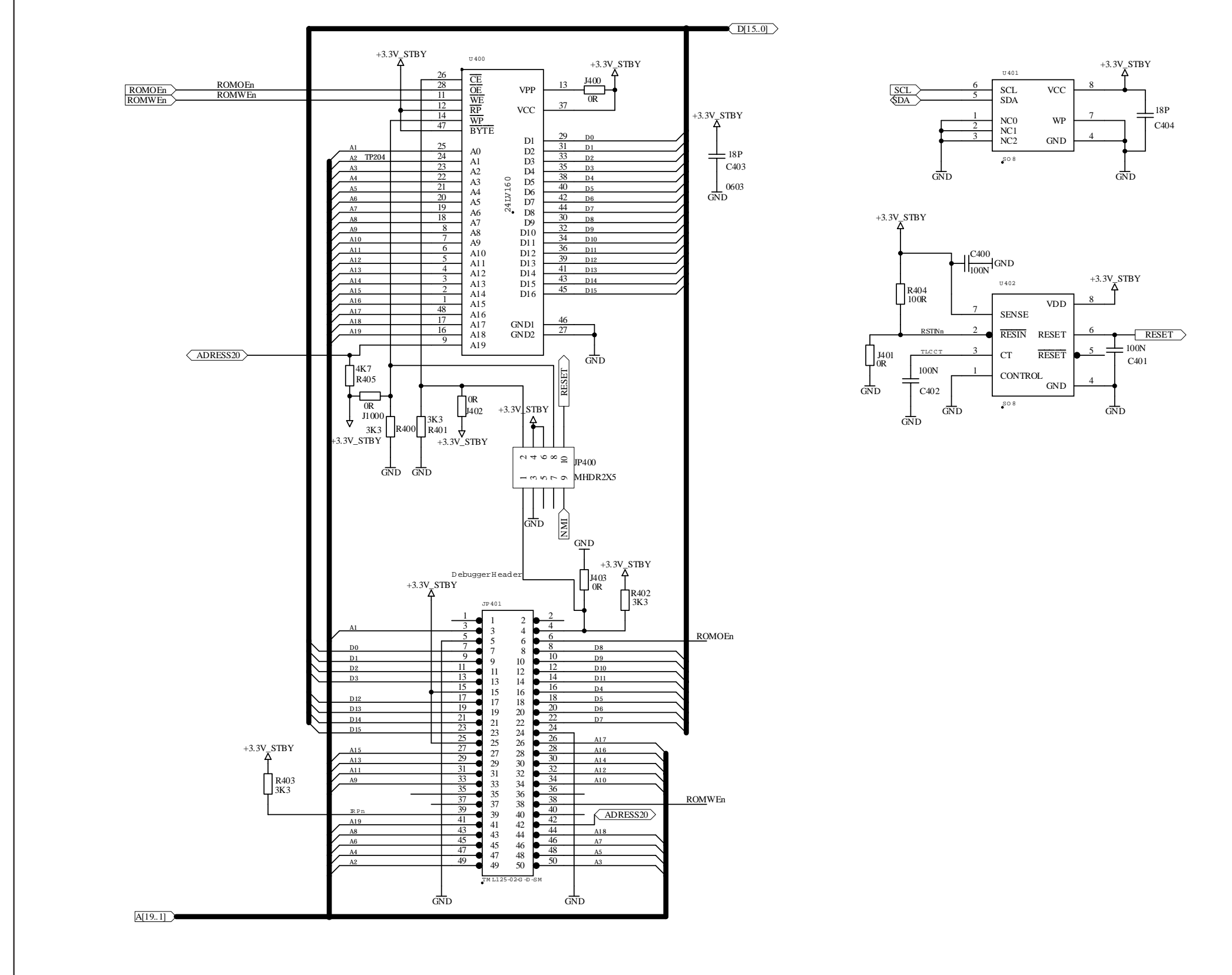

SCALER

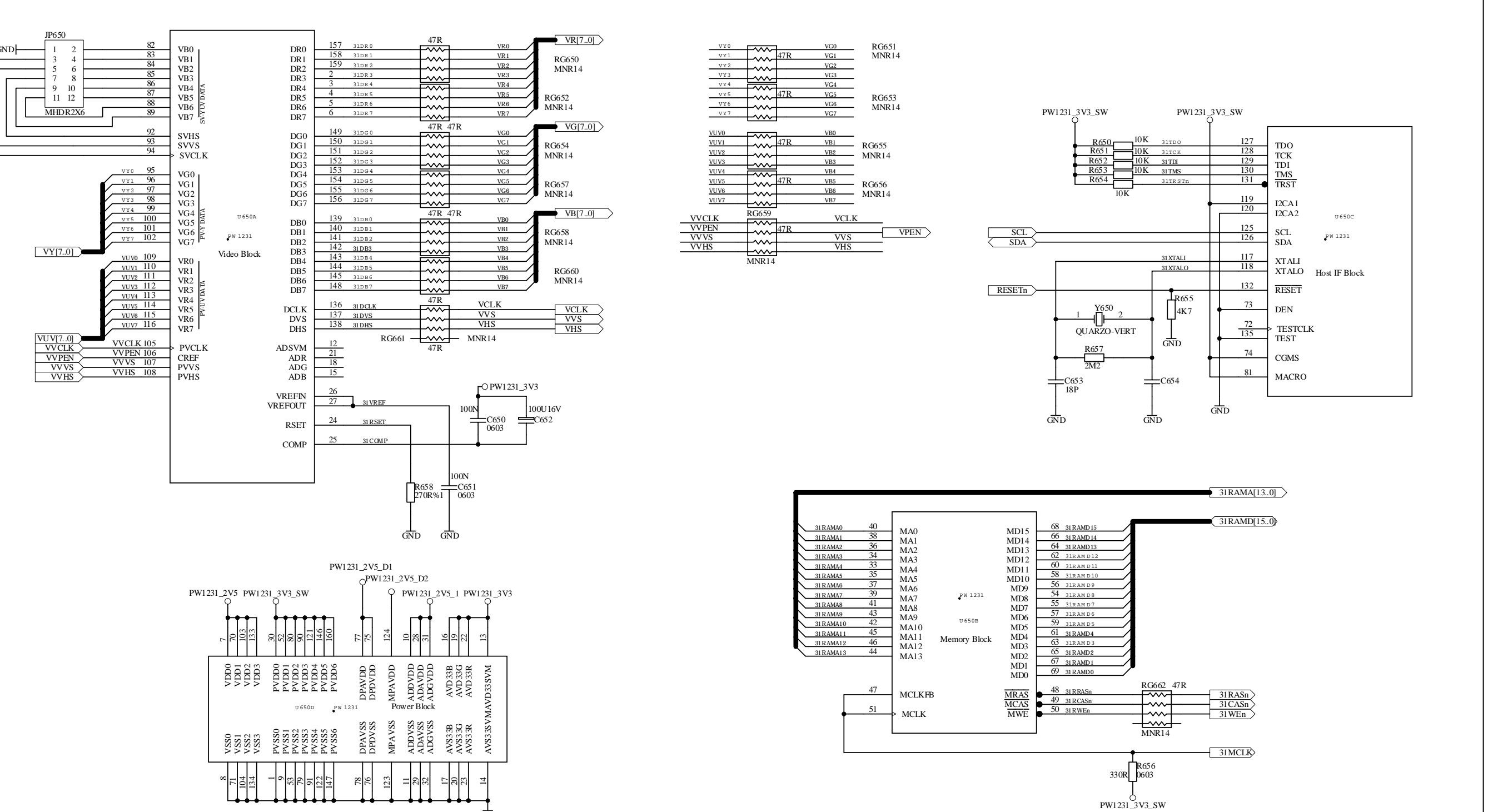

VIDEO DECODER

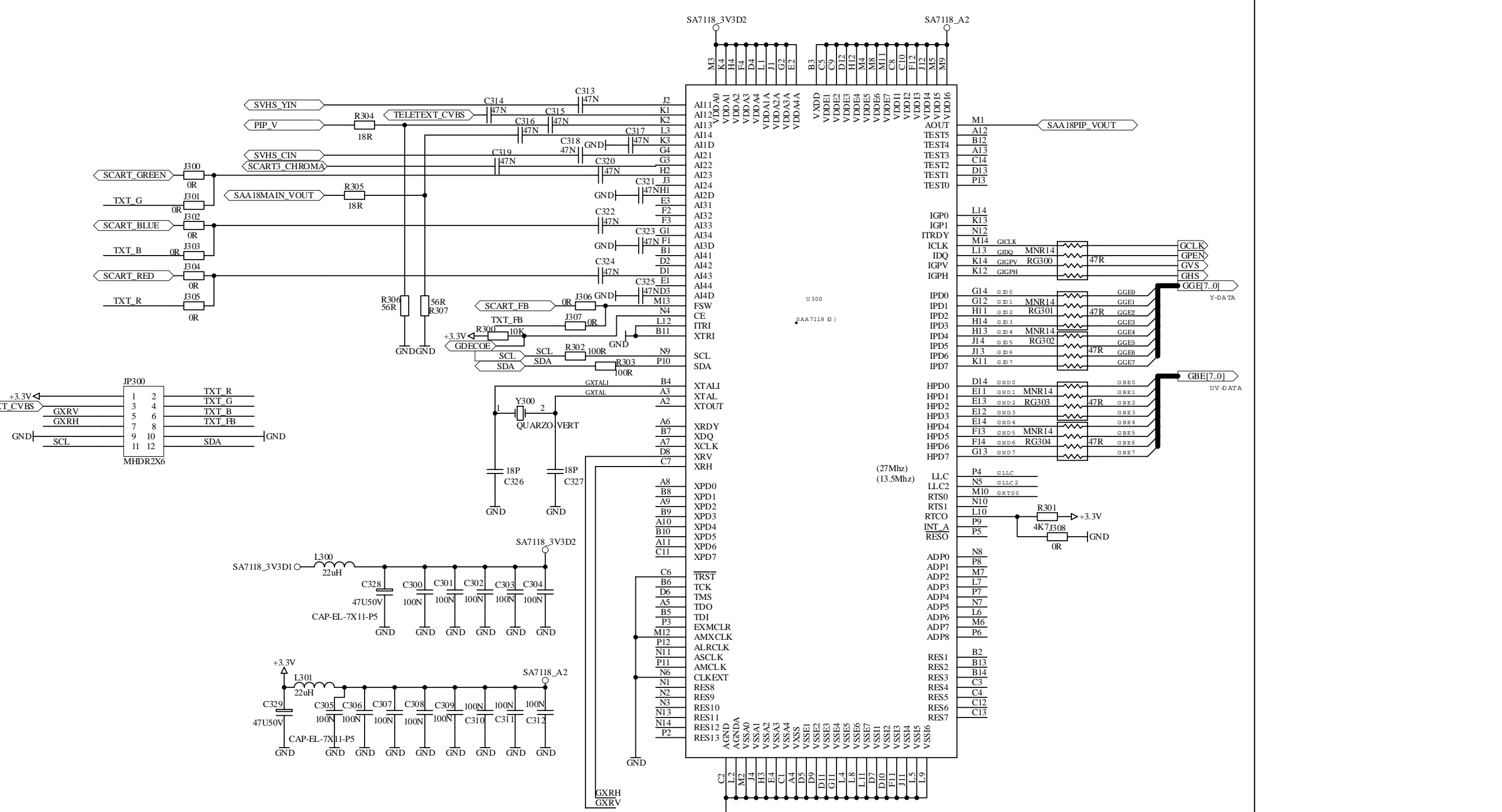

MICROPROCESSOR

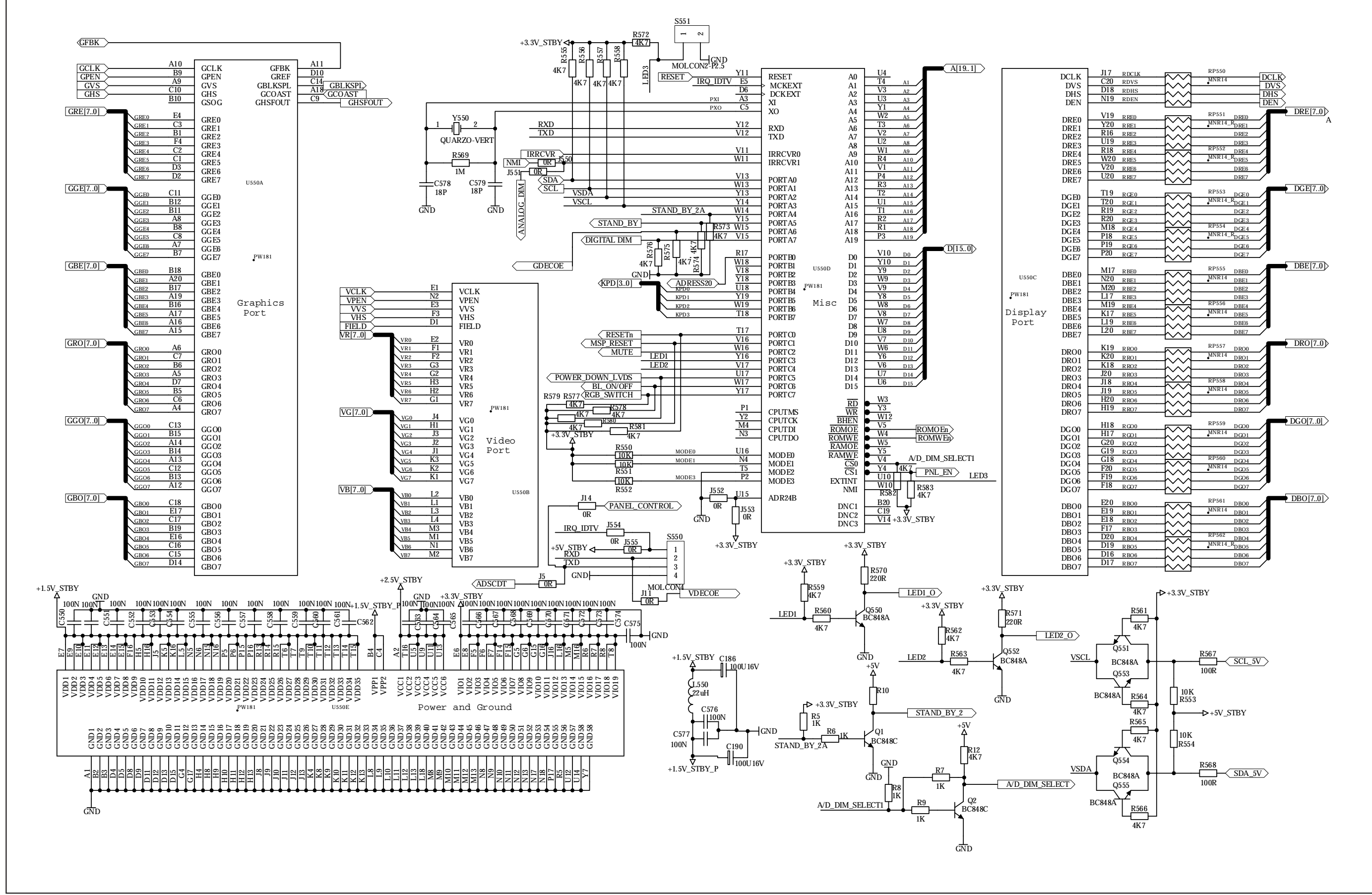

SCALER-RAM

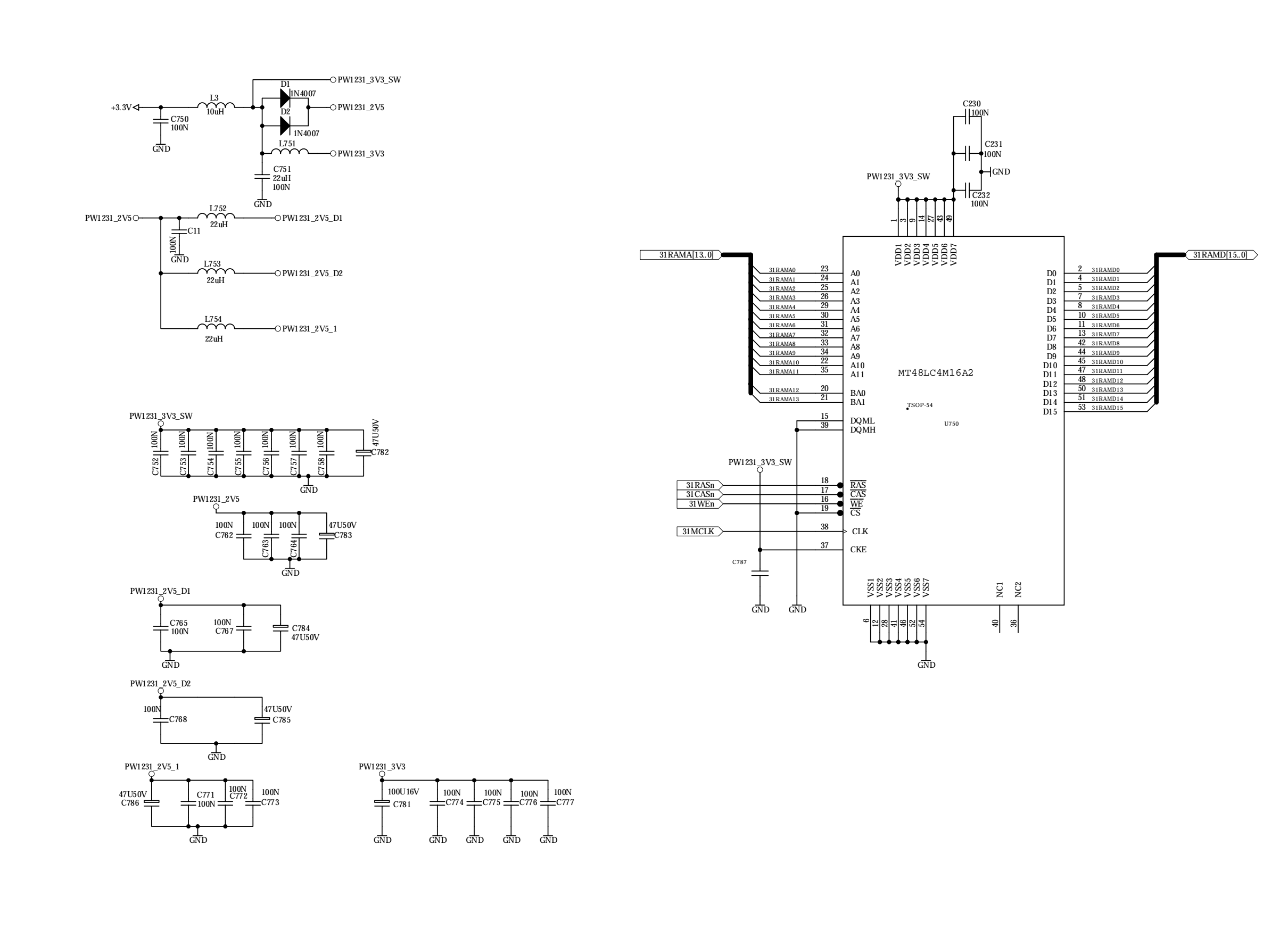

BLOCK DIAGRAM

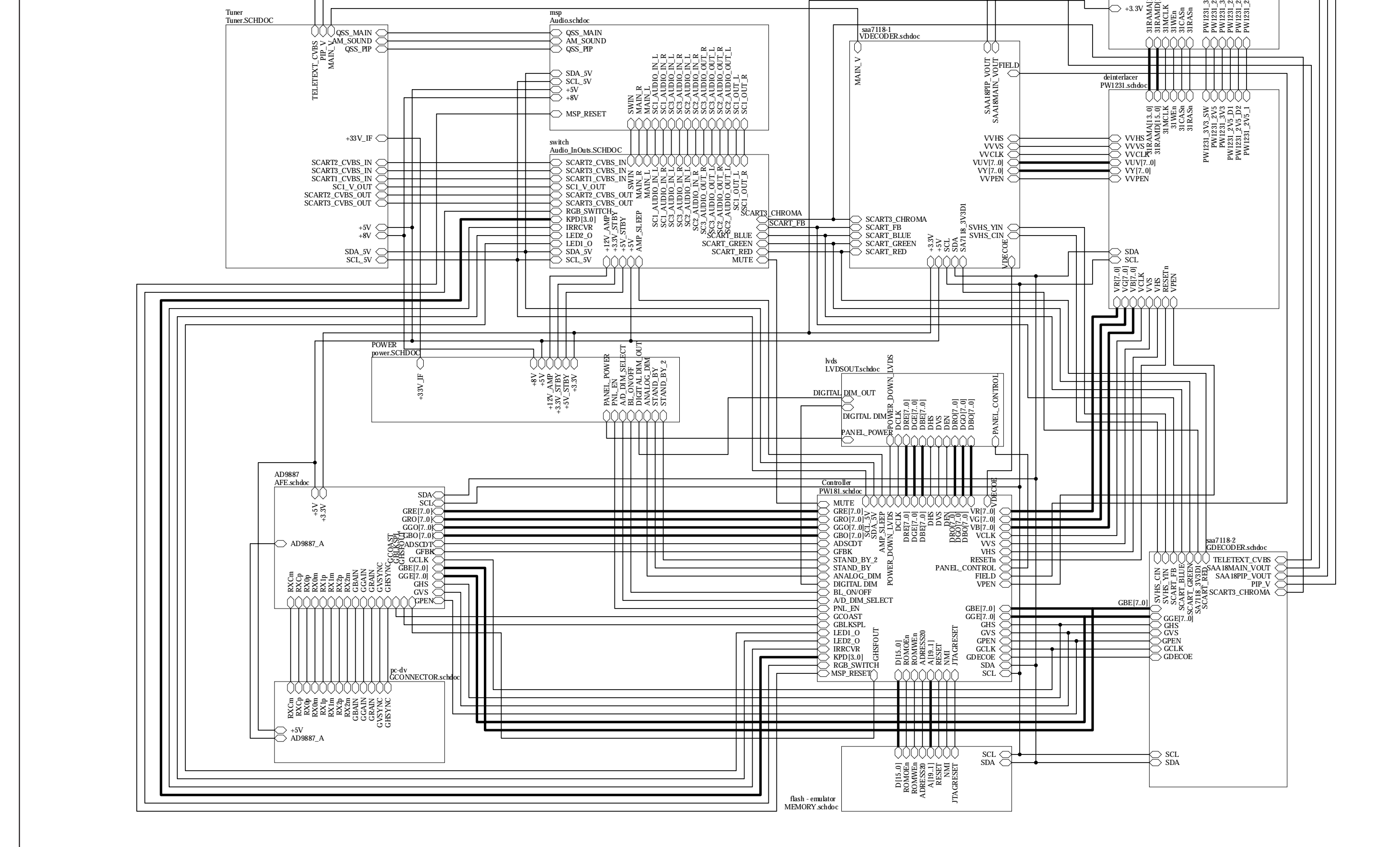

TUNER

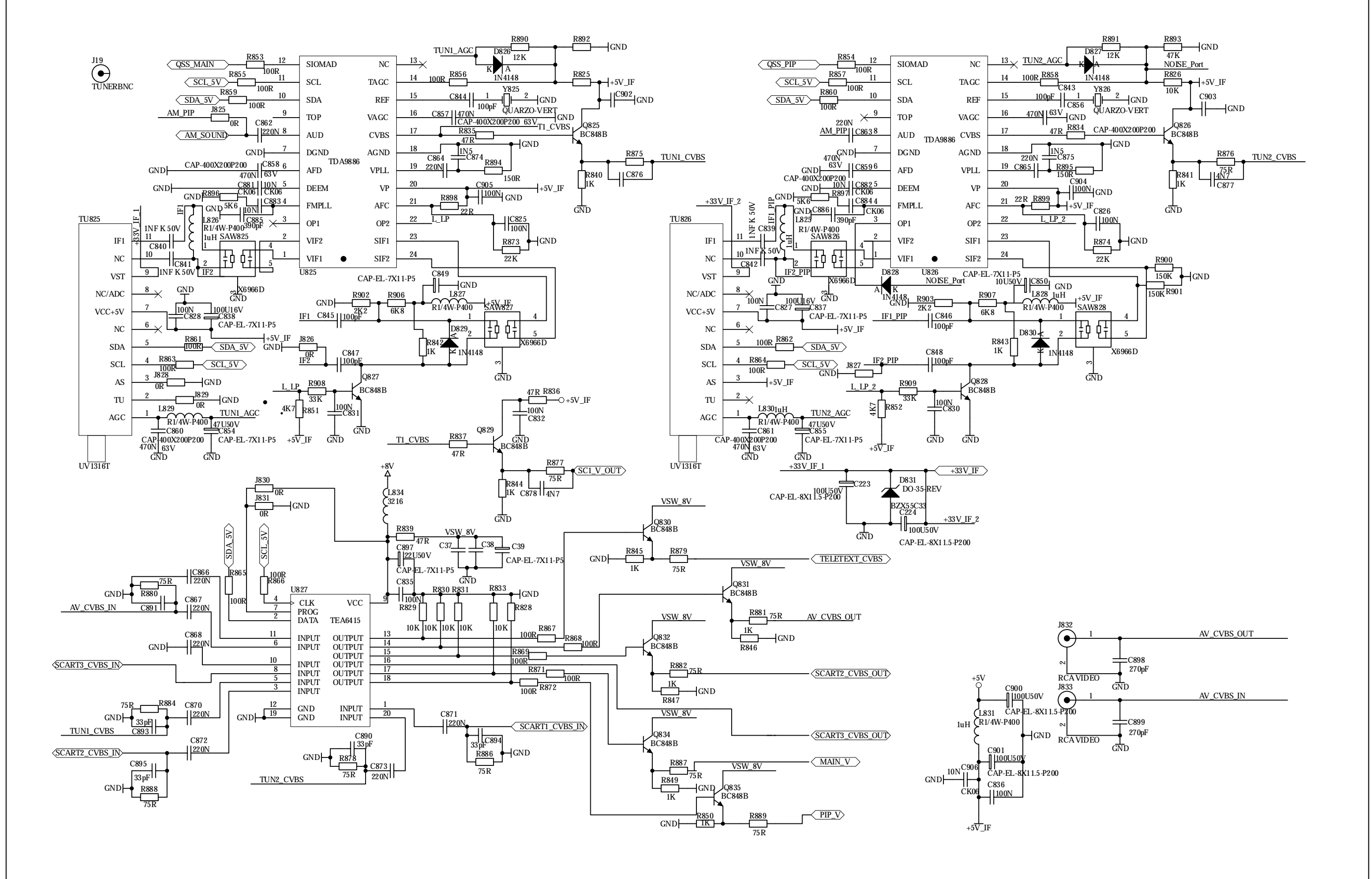

VIDEO DECODER

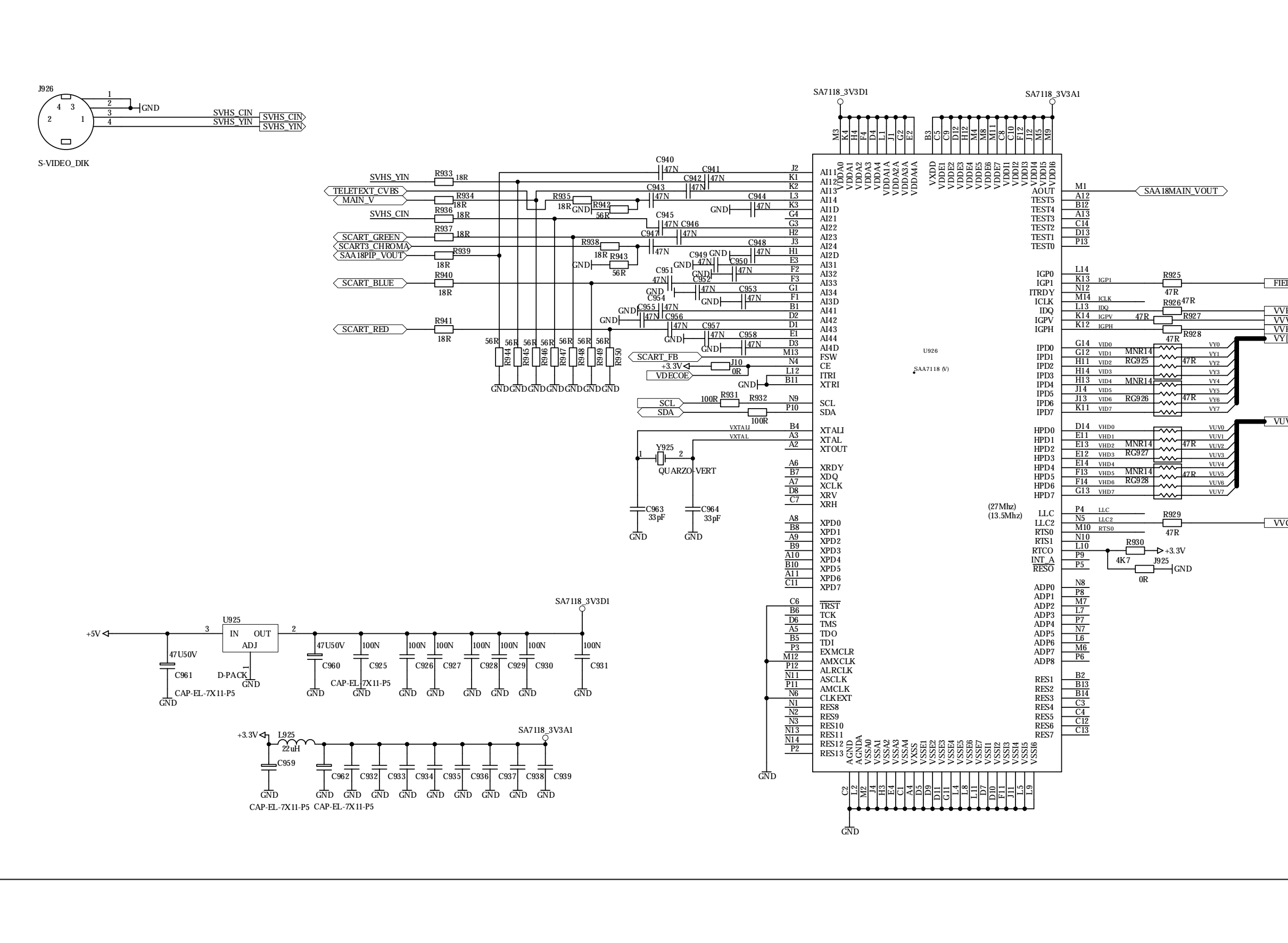

SCART MODULE

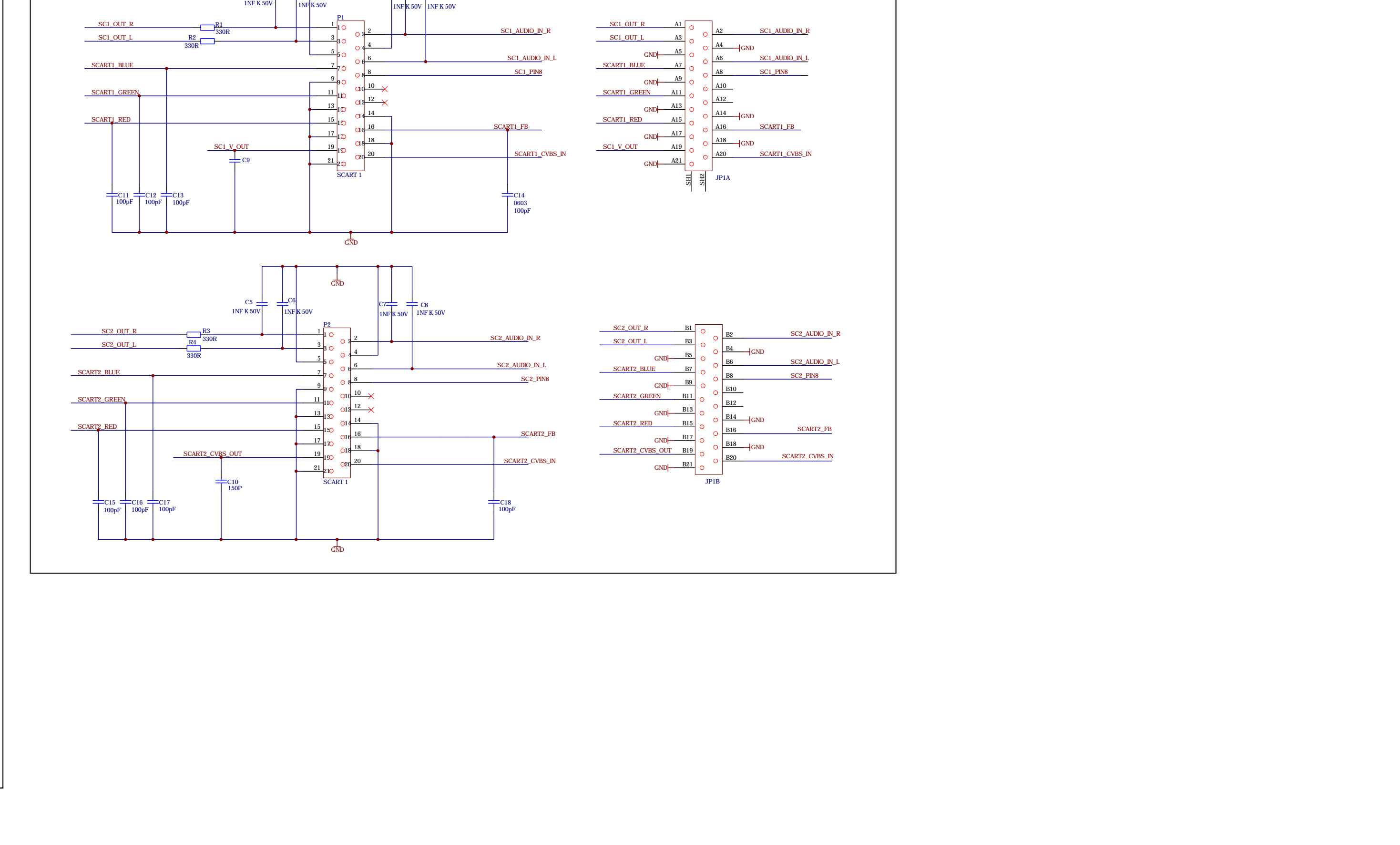

OPTIONAL LED MODULE

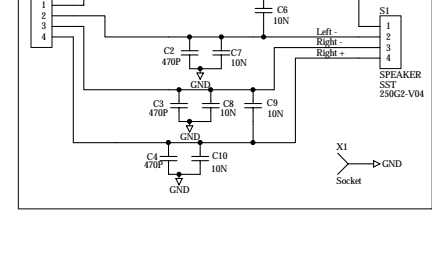

KEYBOARD MODULE

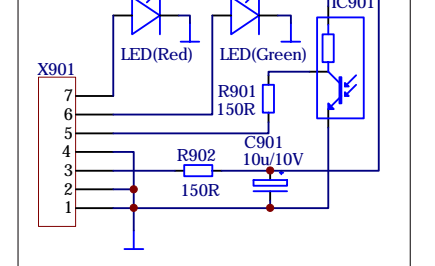

KEYBOARD MODULE

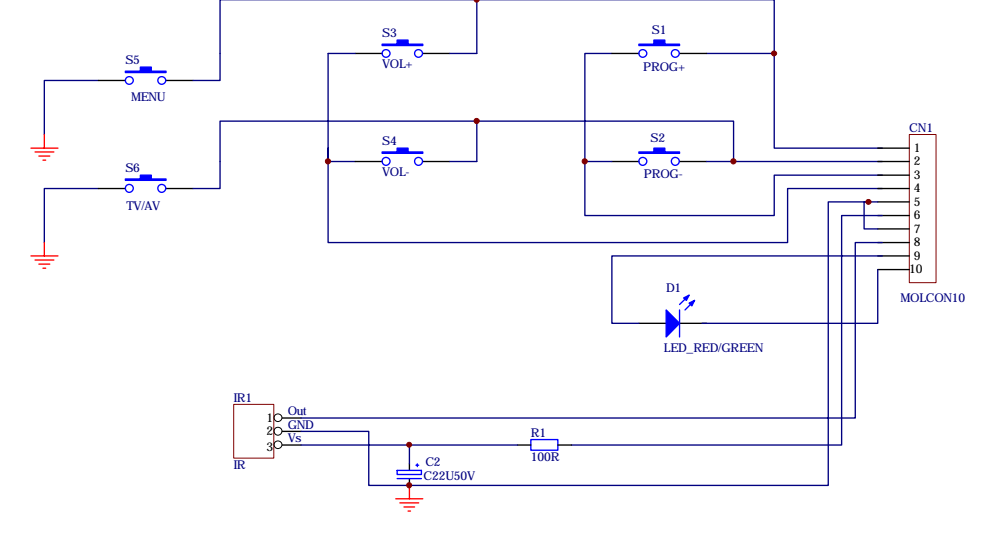

SMPS MODULE

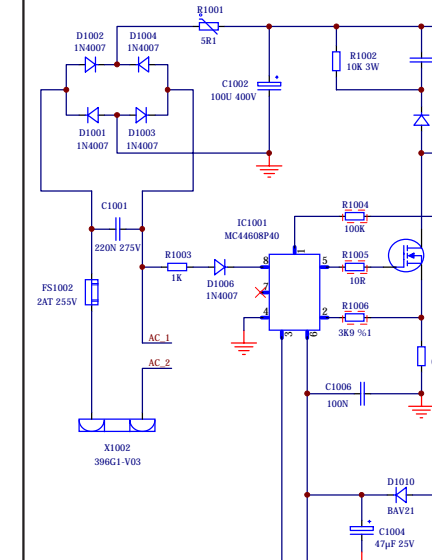

SMPS MODULE

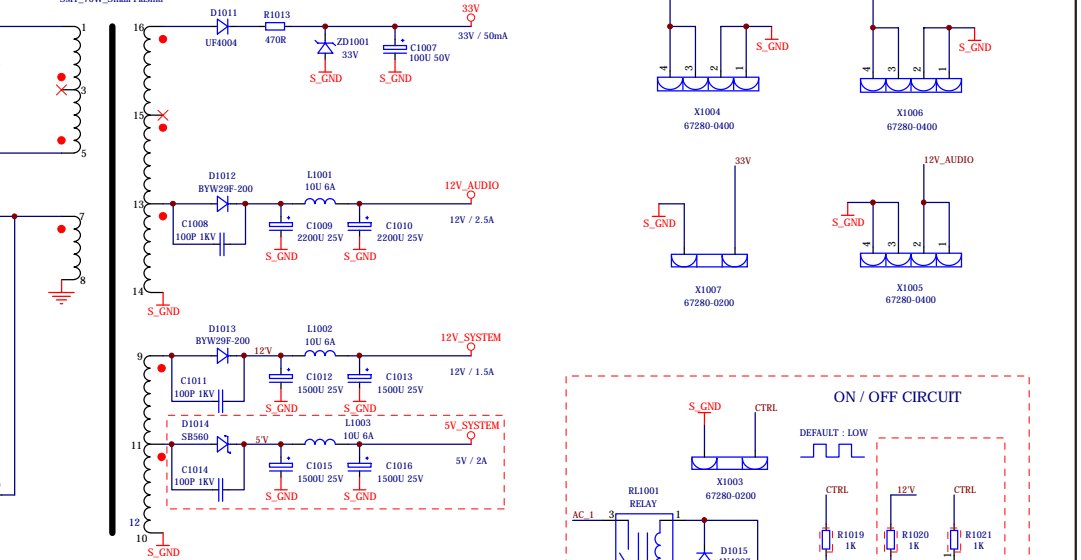

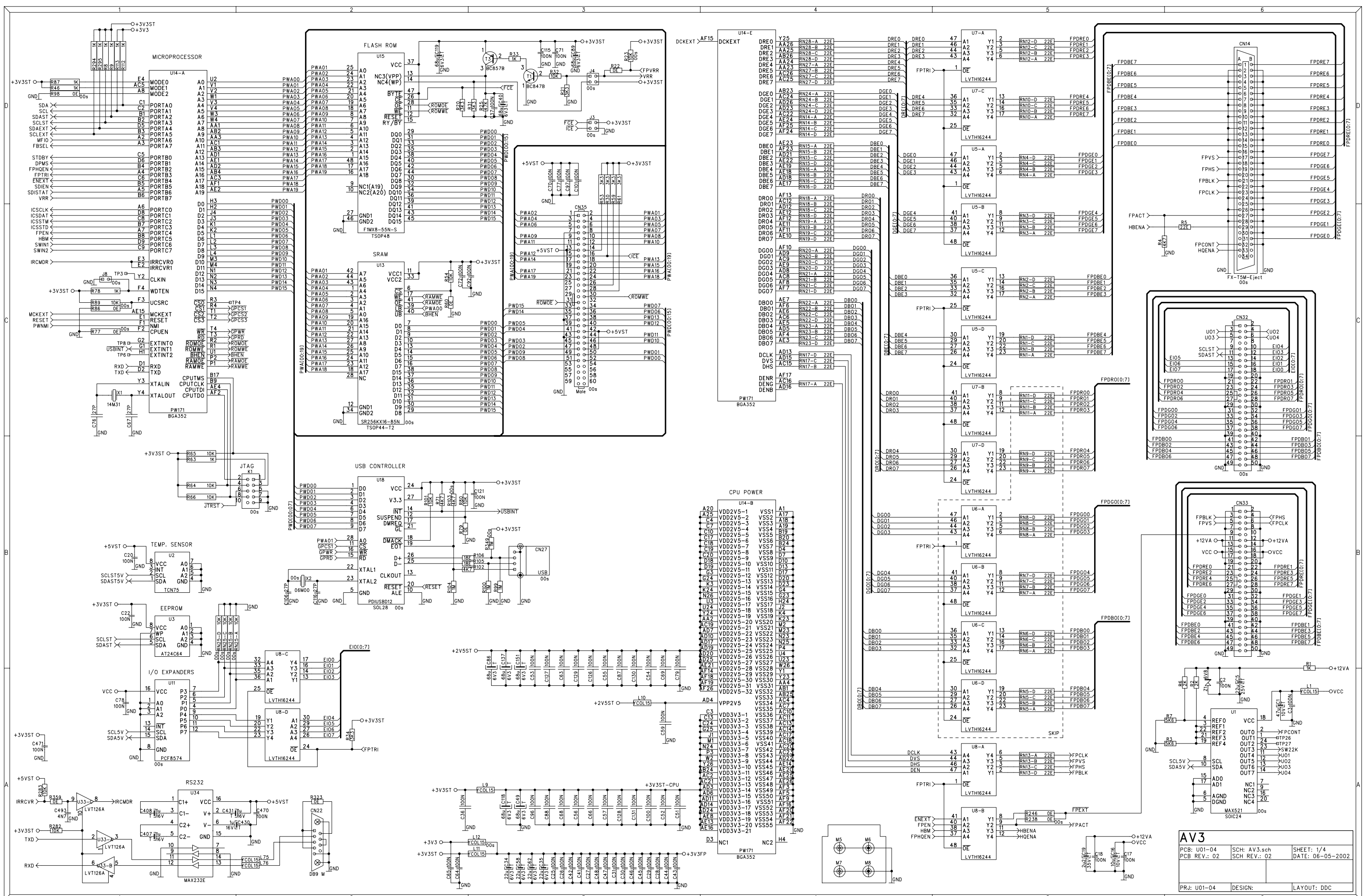

AV3
 PCB: U01-04 SCH: AV3.sch SHEET: 1/4
 PCB REV.: 02 SCH REV.: 02 DATE: 06-05-2002
 PRJ: U01-04 DESIGN: LAYOUT: DDC

Ref	Qty	Name	Option	Remark
A1	1	BRD001-04	99	---

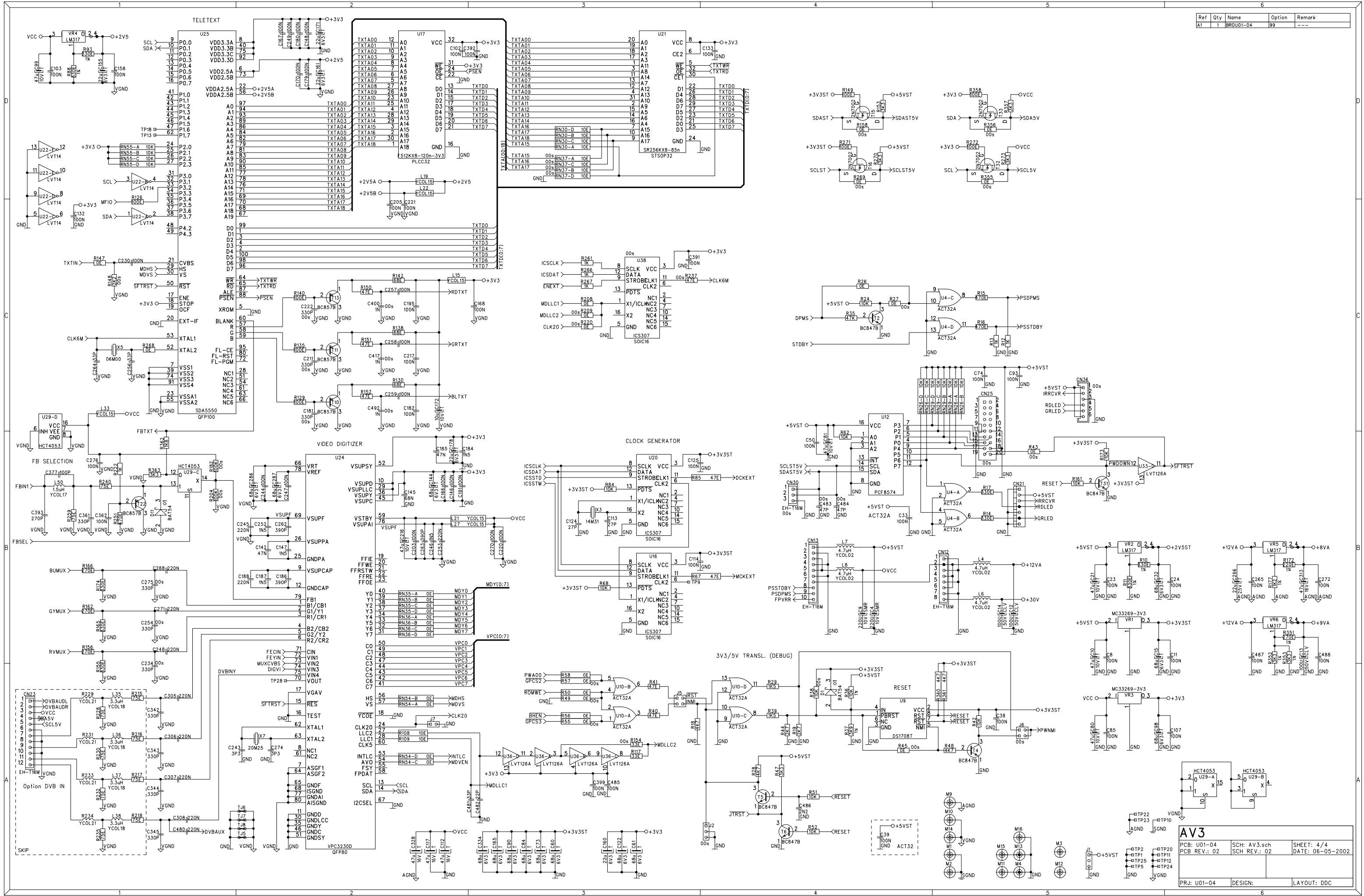

AV3

PCB: U01-04 SCH: AV3.sch SHEET: 4/4
 PCB REV.: 02 SCH REV.: 02 DATE: 06-05-2002

PRJ: U01-04 DESIGN: LAYOUT: DDC

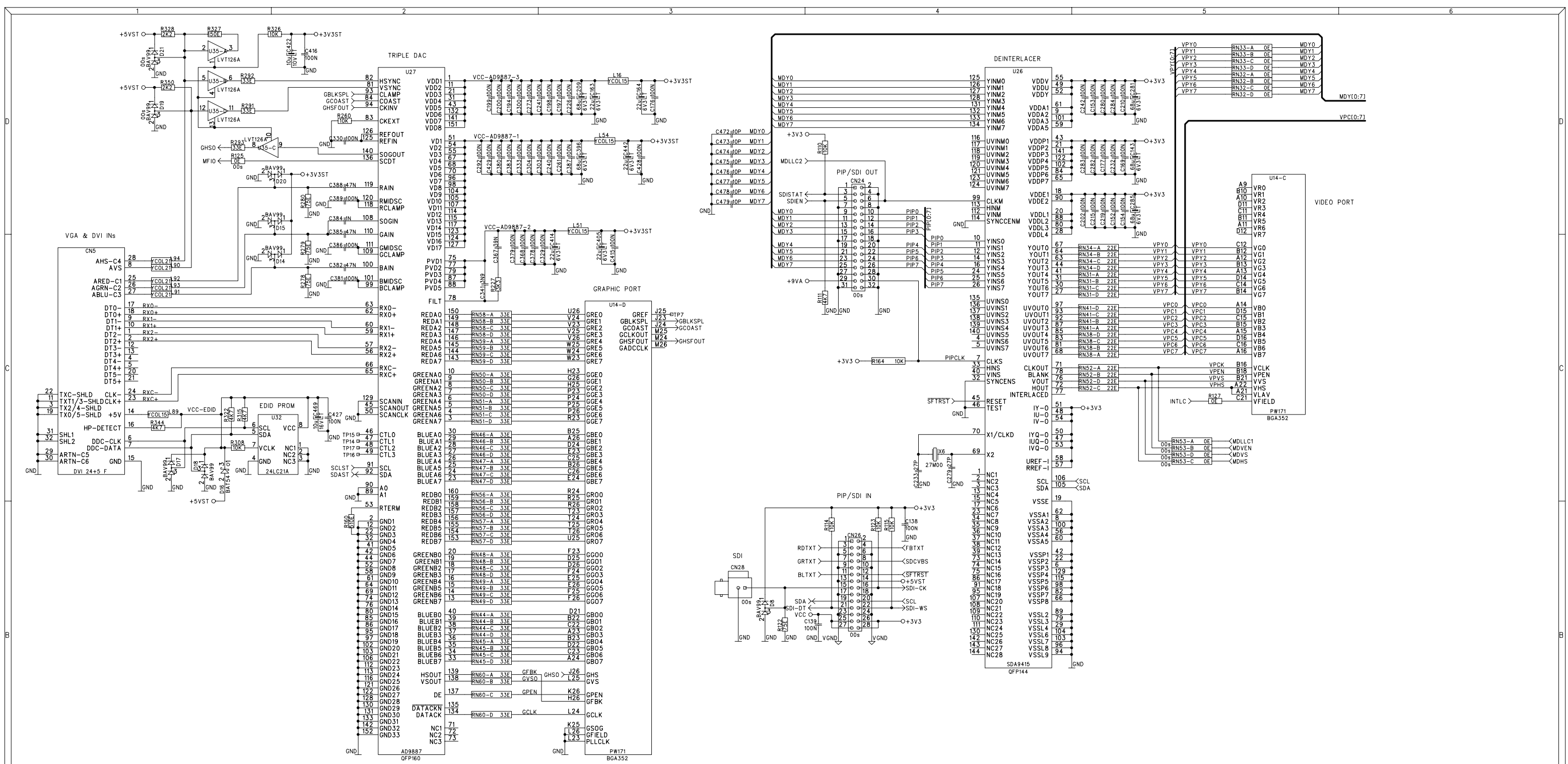

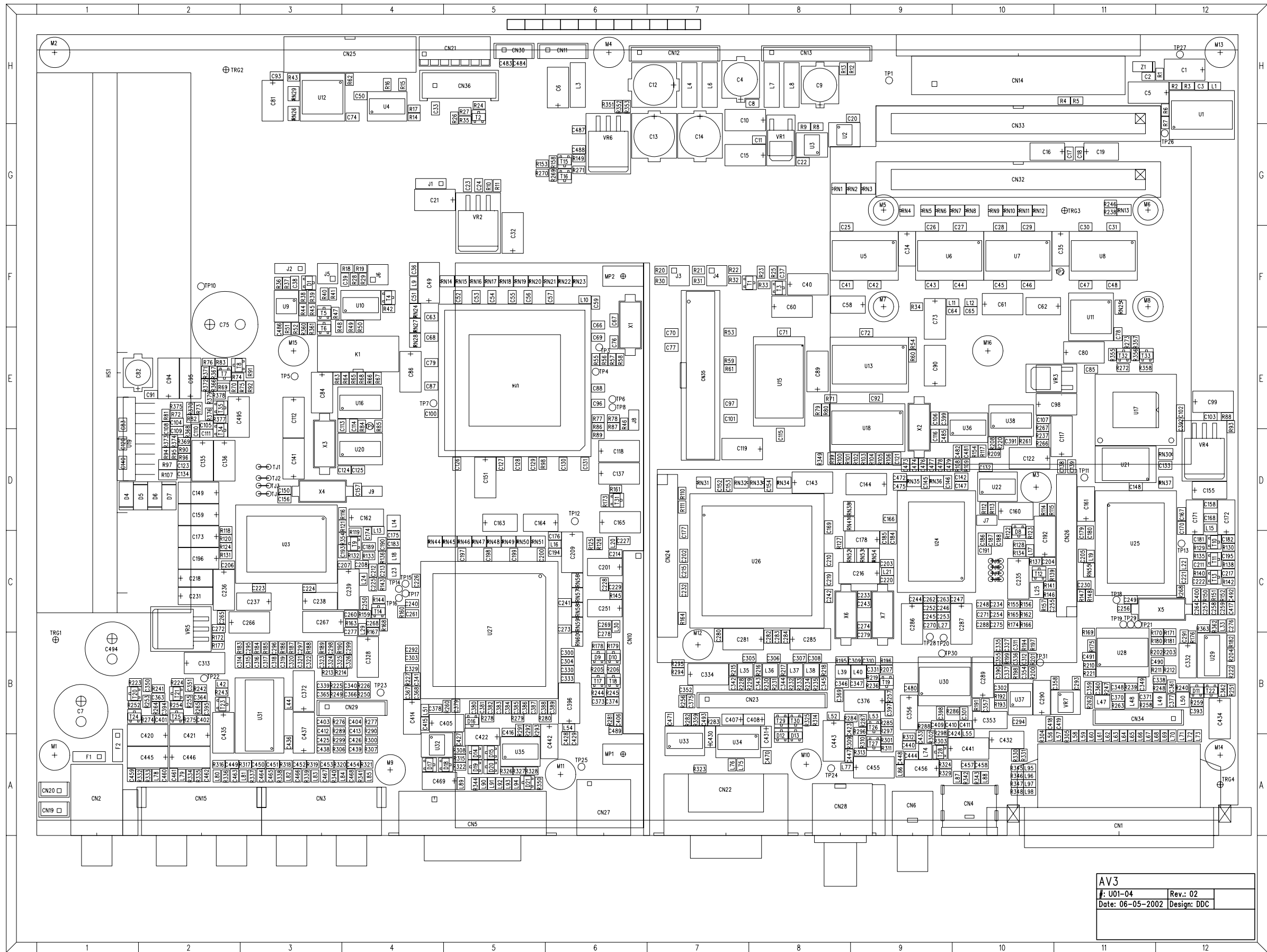

AV3
 #: U01-04 Rev.: 02
 Date: 06-05-2002 Design: DDC

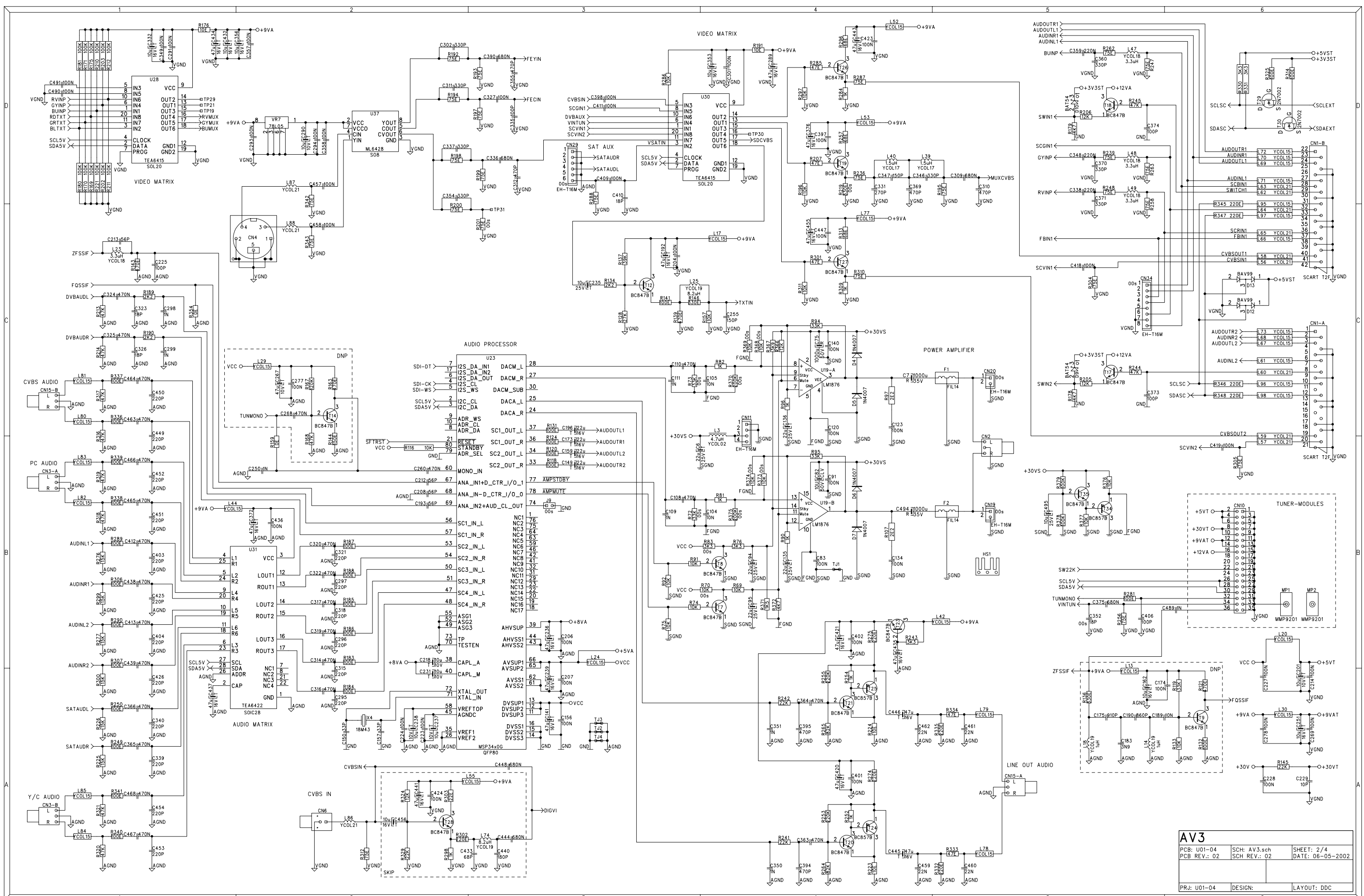

AV3		
PCB: U01-04	SCH: AV3.sch	SHEET: 2 / 4
PCB REV.: 02	SCH REV.: 02	DATE: 06-05-2002
PRJ: U01-04	DESIGN:	LAYOUT: DDC