

	<b>MStar Semiconductor(Shenzhen),Inc.</b>
<b>POWER&amp;DPWM</b>	
Size B	Document Number <b>MARIA2</b>
Date: Sunday, October 22, 2006	Sheet 1 of 3

# Change Bead to Resistance for Glitch Prevention

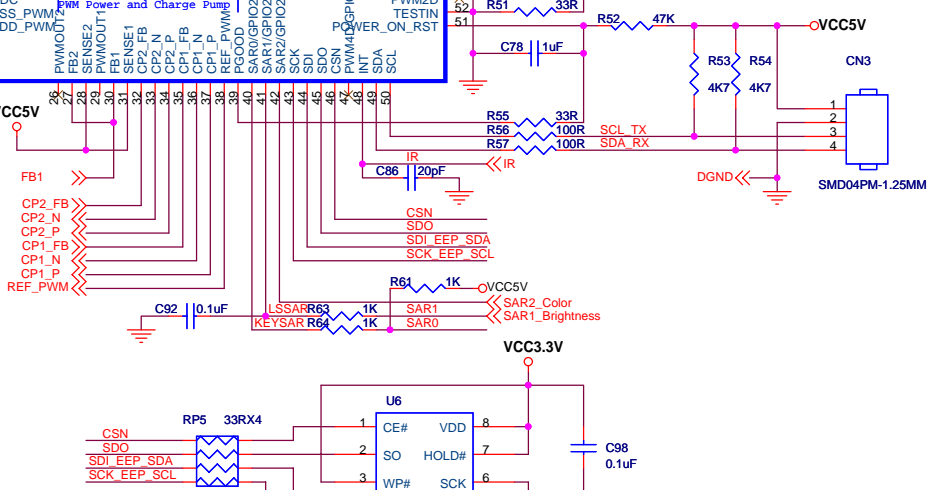
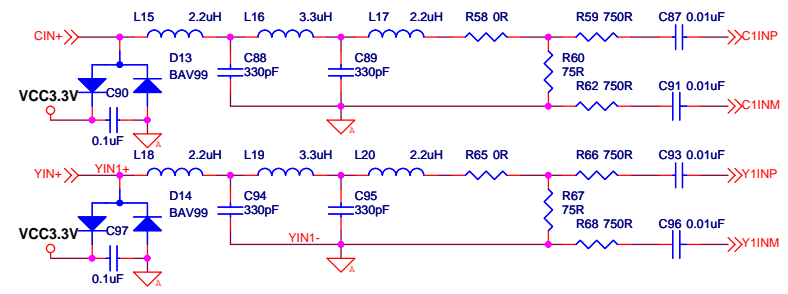
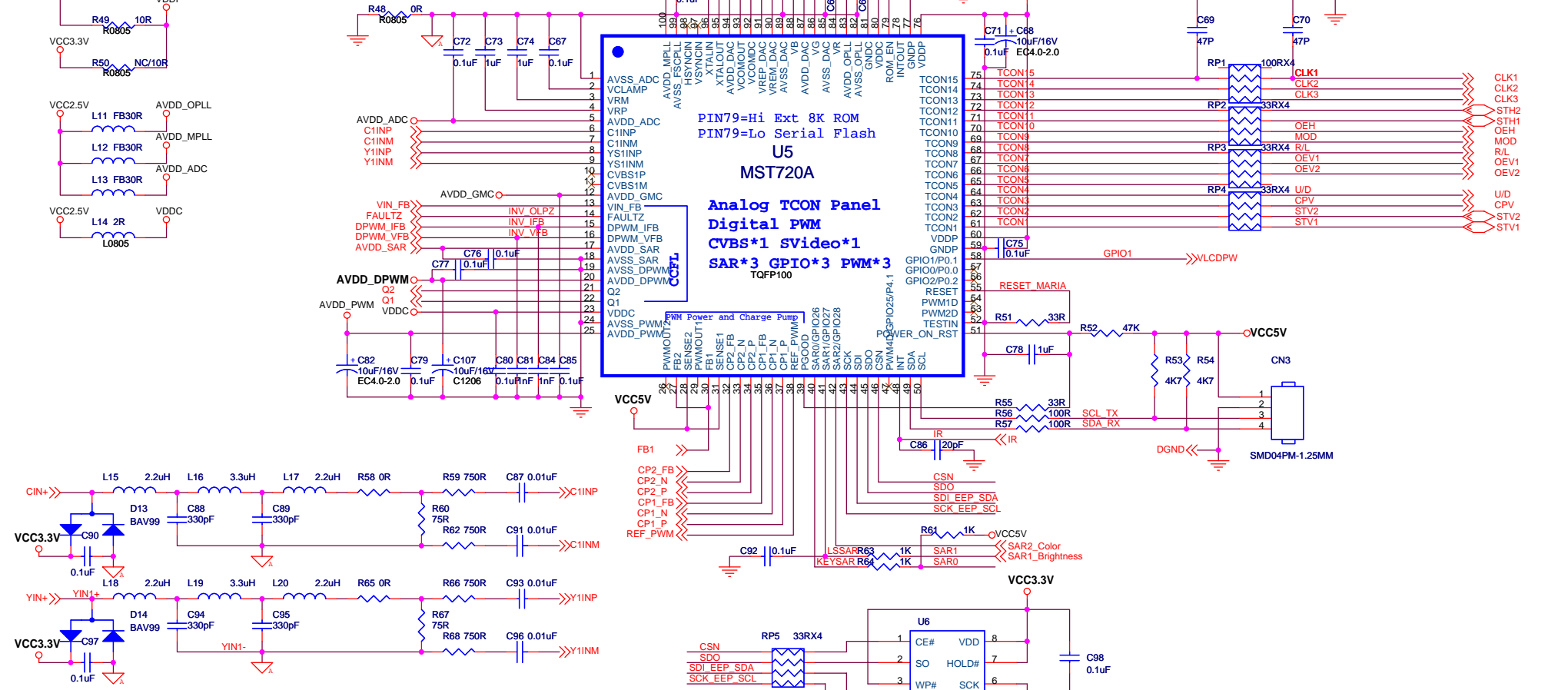
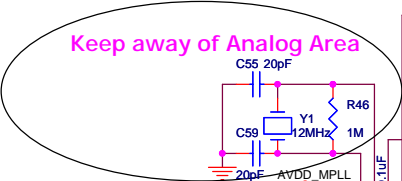
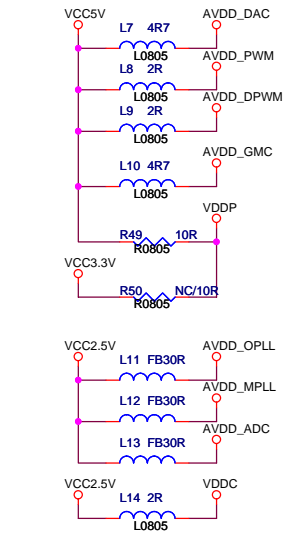

DRG	<b>MStar Semiconductor(Shenzhen),Inc.</b>		
Title	<b>MST720A</b>		
Size	Document Number	Rev	
B	<b>MARIA2</b>	A	
<Model No>	Date:	Sunday, October 22, 2006	Sheet 2 of 3

R/B None SWAP on LG Panel

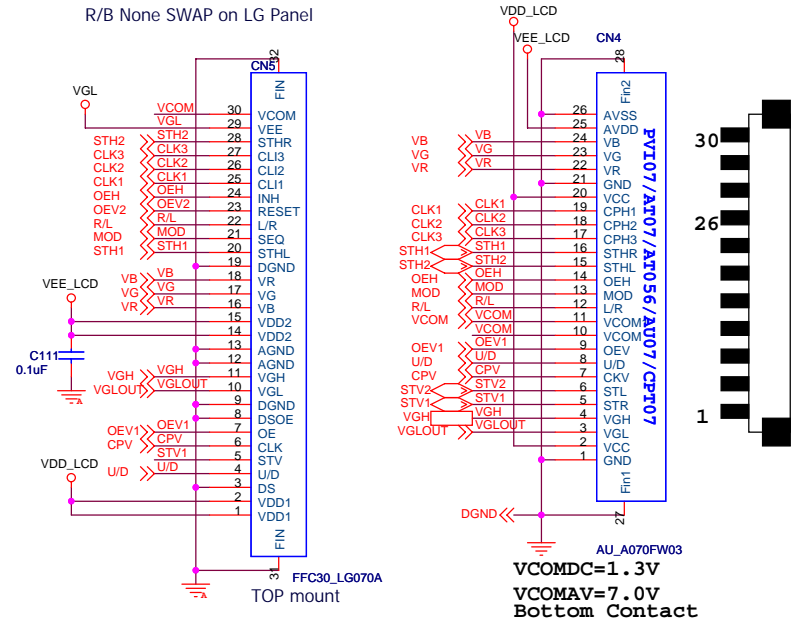

VCOMDC=1.3V  
VCOMAV=7.0V  
Bottom Contact

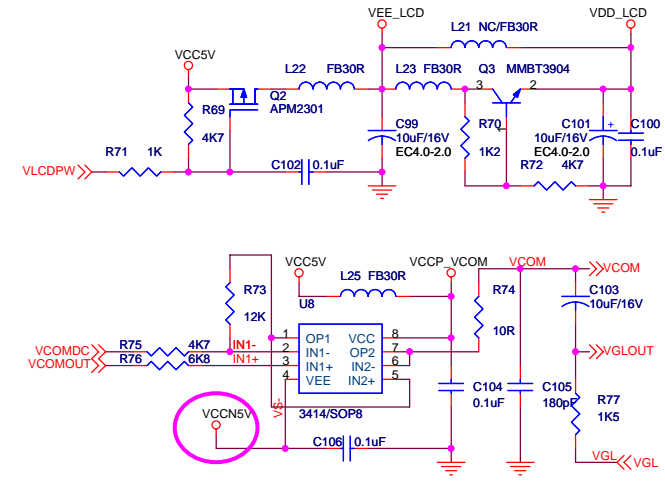
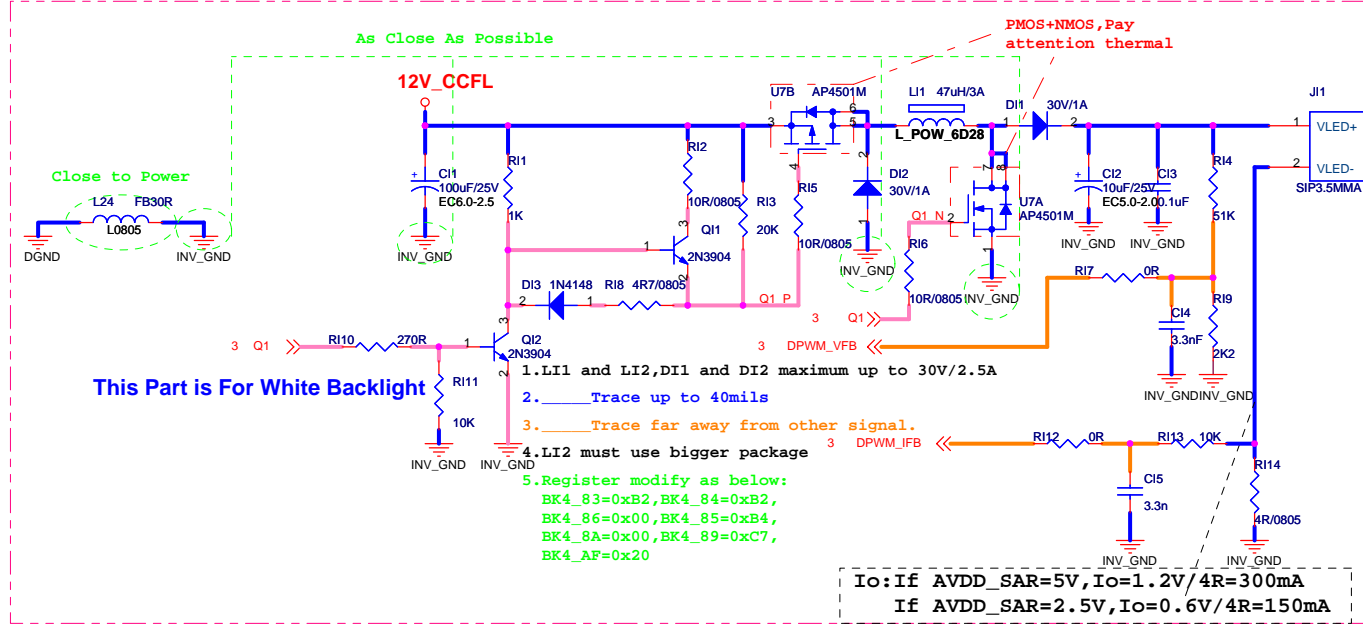

DRG	<b>MStar Semiconductor(Shenzhen),Inc.</b>		
Title	<b>Analog Panel</b>		
Size	Document Number	Rev	
B	<b>MARIA2</b>	A	
<Model No>	Date:	Sunday, October 22, 2006	Sheet 3 of 3