

JVC

SERVICE MANUAL

CD/SD RECEIVER

KD-LHX551, KD-LHX552, KD-LHX557

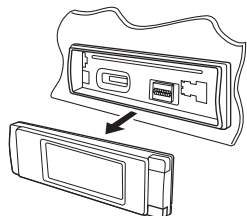

EXAD

KD-LHX551/KD-LHX552

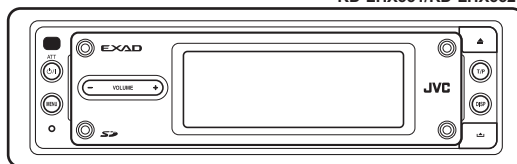

KD-LHX557

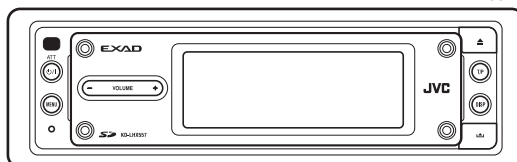

KD-LHX551, KD-LHX552

Area suffix

E ----- Southern Europe
 EX ----- Northern Europe
 EY ----- Eastern Europe
 EU ----- Turkey

KD-LHX557

Area suffix

EE ----- Russian Federation

	KD-LHX551	KD-LHX552	KD-LHX557
Control Panel	SILVER	BLACK	BLACK

TABLE OF CONTENTS

1	PRECAUTIONS	1-3
2	SPECIFIC SERVICE INSTRUCTIONS	1-6
3	DISASSEMBLY	1-7
4	ADJUSTMENT	1-23
5	TROUBLESHOOTING	1-34

SPECIFICATION

AUDIO AMPLIFIER SECTION

Maximum Power Output	Front	52 W per channel
	Rear	52 W per channel
Continuous Power Output (RMS)	Front	19 W per channel into 4 Ω , 40 Hz to 20 000 Hz at no more than 0.8% total harmonic distortion.
	Rear	19 W per channel into 4 Ω , 40 Hz to 20 000 Hz at no more than 0.8% total harmonic distortion.
Load Impedance	4 Ω (4 Ω to 8 Ω allowance)	
Equalizer Control Range	Frequencies	60 Hz, 150 Hz, 400 Hz, 1 kHz, 2.4 kHz, 6 kHz, 12 kHz
	Level	\pm 10 dB
Frequency Response	40 Hz to 20 000 Hz	
Signal-to-Noise Ratio	70 dB	
Line-Out Level/Impedance	5.0 V/20 k Ω load (full scale)	
Output Impedance	1 k Ω	
Subwoofer-Out Level/Impedance	5.0 V/20 k Ω load (full scale)	
Other Terminals	LINE IN, CD changer, Steering wheel remote input	

TUNER SECTION

Frequency Range	FM	87.5 MHz to 108.0 MHz
	AM	(MW) 522 kHz to 1 620 kHz (LW) 144 kHz to 279 kHz
FM Tuner	Usable Sensitivity	11.3 dBf (1.0 μ V/75 Ω)
	50 dB Quieting Sensitivity	16.3 dBf (1.8 μ V/75 Ω)
	Alternate Channel Selectivity (400 kHz)	65 dB
	Frequency Response	40 Hz to 15 000 Hz
	Stereo Separation	30 dB
	Capture Ratio	1.5 dB
MW Tuner	Sensitivity	20 μ V
	Selectivity	65 dB
LW Tuner	Sensitivity	50 μ V

CD/SD PLAYER SECTION

Type	Compact disc player
Signal Detection System	Non-contact optical pickup (semiconductor laser)
Number of Channels	2 channels (stereo)
Frequency Response	5 Hz to 20 000 Hz
Dynamic Range	98 dB
Signal-to-Noise Ratio	102 dB
Wow and Flutter	Less than measurable limit
MP3 (MPEG Audio Layer 3)	Max. Bit Rate: 320 kbps
WMA (Windows Media Audio)	Max. Bit Rate: 192 kbps
Playable SD Card	Format: Fat 12/16
Storage	Up to 512 MB
Playable Audio Format for SD Card	MP3/WMA

GENERAL

Power Requirement	Operating Voltage	DC 14.4 V (11 V to 16 V allowance)
Grounding System	Negative ground	
Allowable Operating Temperature	0°C to +40°C	
Dimensions (W \times H \times D)	Installation Size (approx.)	182 mm \times 52 mm \times 159 mm
	Panel Size (approx.)	188 mm \times 58 mm \times 13 mm
Mass (approx.)	1.9 kg (excluding accessories)	

- Design and specifications are subject to change without notice.
- Microsoft and Windows Media are either registered trademarks or trademarks of Microsoft Corporation in the United States and/or other countries.
- SD logo is a trademark.

SECTION 1 PRECAUTIONS

1.1 Safety Precautions

 **CAUTION** Burrs formed during molding may be left over on some parts of the chassis. Therefore, pay attention to such burrs in the case of performing repair of this system.

 **CAUTION** Please use enough caution not to see the beam directly or touch it in case of an adjustment or operation check.

1.2 Preventing static electricity

Electrostatic discharge (ESD), which occurs when static electricity stored in the body, fabric, etc. is discharged, can destroy the laser diode in the traverse unit (optical pickup). Take care to prevent this when performing repairs.

1.2.1 Grounding to prevent damage by static electricity

Static electricity in the work area can destroy the optical pickup (laser diode) in devices such as CD players.

Be careful to use proper grounding in the area where repairs are being performed.

(1) Ground the workbench

Ground the workbench by laying conductive material (such as a conductive sheet) or an iron plate over it before placing the traverse unit (optical pickup) on it.

(2) Ground yourself

Use an anti-static wrist strap to release any static electricity built up in your body.

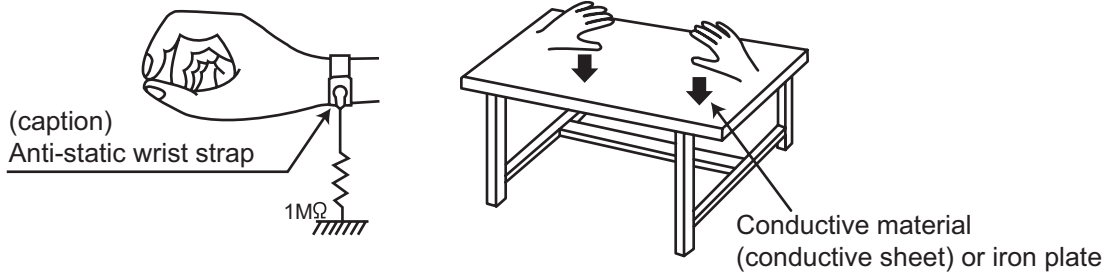

(3) Handling the optical pickup

- In order to maintain quality during transport and before installation, both sides of the laser diode on the replacement optical pickup are shorted. After replacement, return the shorted parts to their original condition. (Refer to the text.)
- Do not use a tester to check the condition of the laser diode in the optical pickup. The tester's internal power source can easily destroy the laser diode.

1.3 Handling the traverse unit (optical pickup)

- (1) Do not subject the traverse unit (optical pickup) to strong shocks, as it is a sensitive, complex unit.
- (2) Cut off the shorted part of the flexible cable using nippers, etc. after replacing the optical pickup. For specific details, refer to the replacement procedure in the text. Remove the anti-static pin when replacing the traverse unit. Be careful not to take too long a time when attaching it to the connector.
- (3) Handle the flexible cable carefully as it may break when subjected to strong force.
- (4) It is not possible to adjust the semi-fixed resistor that adjusts the laser power. Do not turn it.

1.4 Attention when traverse unit is decomposed

***Please refer to "Disassembly method" in the text for the CD pickup unit.**

- Apply solder to the short land before the flexible wire is disconnected from the connector on the CD pickup unit. (If the flexible wire is disconnected without applying solder, the CD pickup may be destroyed by static electricity.)
- In the assembly, be sure to remove solder from the short land after connecting the flexible wire.

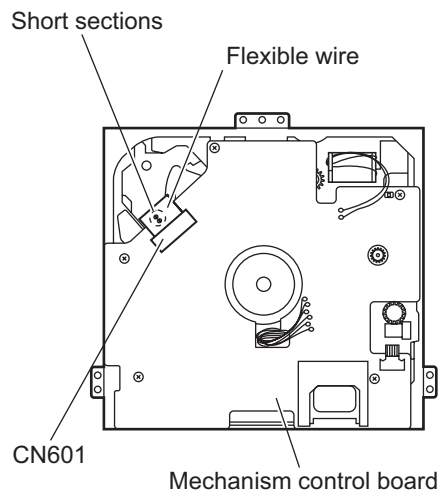

1.5 Important for laser products

1.CLASS 1 LASER PRODUCT

2.DANGER : Invisible laser radiation when open and interlock failed or defeated. Avoid direct exposure to beam.

3.CAUTION : There are no serviceable parts inside the Laser Unit. Do not disassemble the Laser Unit. Replace the complete Laser Unit if it malfunctions.

4.CAUTION : The CD,MD and DVD player uses invisible laser radiation and is equipped with safety switches which prevent emission of radiation when the drawer is open and the safety interlocks have failed or are defeated. It is dangerous to defeat the safety switches.

5.CAUTION : If safety switches malfunction, the laser is able to function.

6.CAUTION : Use of controls, adjustments or performance of procedures other than those specified here in may result in hazardous radiation exposure.

 **CAUTION** Please use enough caution not to see the beam directly or touch it in case of an adjustment or operation check.

CAUTION : Visible and invisible laser radiation when open and interlock failed or defeated.
AVOID DIRECT EXPOSURE TO BEAM.

ADVARSEL : Synlig og usynlig laserstråling når maskinen er åben eller interlocken fejler. Undgå direkte eksponering til stråling.

VARNING : Synlig och osynlig laserstråling när den öppnas och spärren är urkopplad. Betrakta ej strålen.

VARO : Avattaessa ja suojalukitus ohitettuna tai viallisena olet alttiina näkyvälle ja näkymättömälle lasersäteilylle. Vältä säteen kohdistumista suoraan itseesi.

REPRODUCTION AND POSITION OF LABELS

WARNING LABEL



<p>CAUTION : Visible and Invisible laser radiation when open and interlock failed or defeated. AVOID DIRECT EXPOSURE TO BEAM. (e)</p>	<p>ADVARSEL : Synlig og usynlig laserstråling når maskinen er åben eller interlocken fejler. Undgå direkte eksponering til stråling. (d)</p>	<p>VARNING : Synlig och osynlig laserstråling när den öppnas och spärren är urkopplad. Betrakta ej strålen. (s)</p>	<p>VARO : Avattaessa ja suojalukitus ohitettuna tai viallisena olet alttiina näkyvälle ja näkymättömälle lasersäteilylle. Vältä säteen kohdistumista suoraan itseesi. (f)</p>
--	---	--	--

SECTION 2
SPECIFIC SERVICE INSTRUCTIONS

This service manual does not describe SPECIFIC SERVICE INSTRUCTIONS.

SECTION 3 DISASSEMBLY

3.1 Main body section

3.1.1 Removing the front panel assembly (See Fig.1)

- (1) Push the detach button in the lower right part of the front panel assembly.
- (2) Remove the front panel assembly.

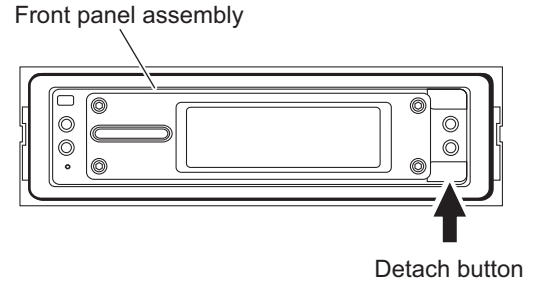

Fig.1

3.1.2 Removing the heat sink (See Fig.2)

Reference:

- Remove the front panel assembly as required.
- (1) From the left side of the main body, remove the two screws **A** and three screws **B** attaching the heat sink.
 - (2) Remove the heat sink from the main body.

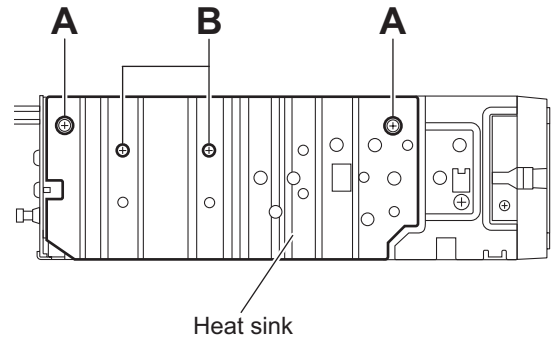

Fig.2

3.1.3 Removing the top chassis assembly (See Figs.3 to 6)

- Prior to performing the following procedures, remove the heat sink.

Reference:

Remove the front panel assembly as required.

- (1) From the bottom side of the main body, remove the two screws **C** attaching the top chassis assembly to the bottom chassis assembly. (See Fig.3)
- (2) From the both and rear sides of the main body, remove the four screws **D** attaching the top chassis assembly to the bottom chassis assembly. (See Figs.4 to 6)
- (3) Remove the screw **E** attaching the IC heat sink to bottom chassis assembly. (See Fig.5)
- (4) Lift the top chassis assembly in the direction of the arrow, disconnect the connector **CN503** on the mechanism control board from the connector **CN721** on the main board. (See Figs.4 to 6)
- (5) Take out the top chassis assembly from the bottom chassis assembly.

Reference:

Remove the screw **E'** and the IC heat sink as required. (See Fig5)

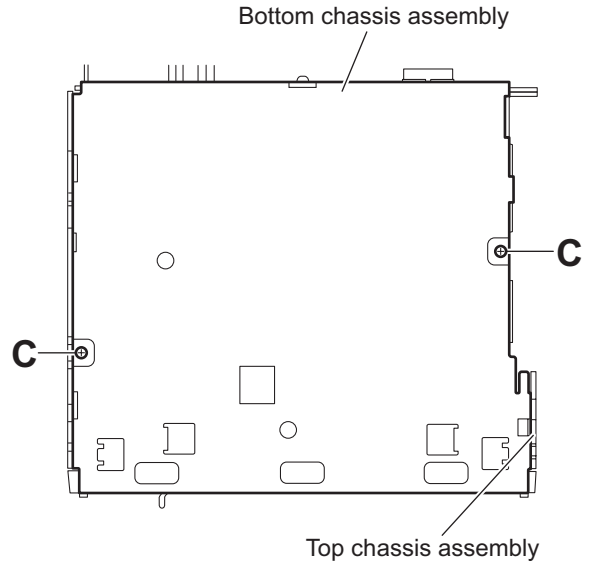

Fig.3

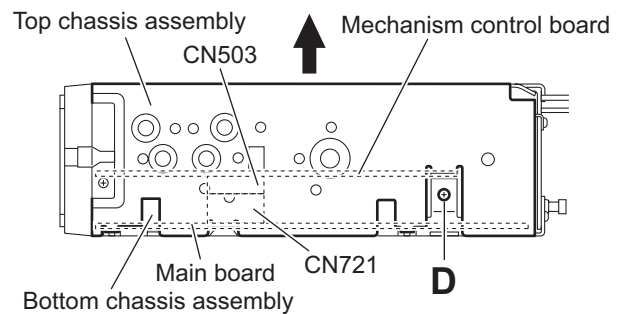

Fig.4

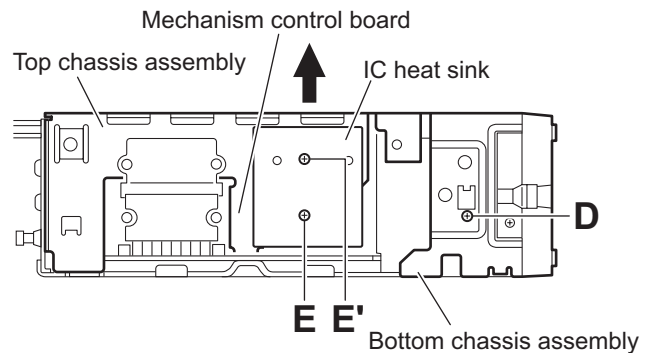

Fig.5

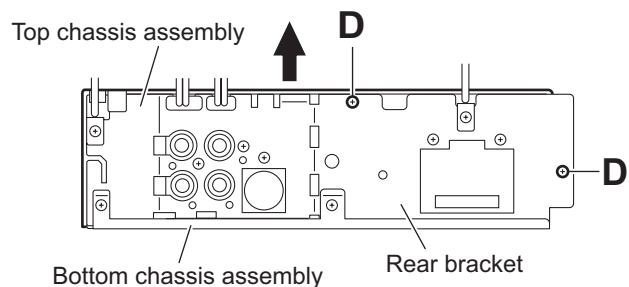

Fig.6

**3.1.4 Removing the front chassis assembly
(See Figs.7 and 8)**

- Prior to performing the following procedure, remove the front panel assembly, heat sink and top chassis assembly.
 - (1) From the both sides of the top chassis assembly, remove the two screws **F** attaching the front chassis assembly.
 - (2) Remove the front chassis assembly from the top chassis assembly.

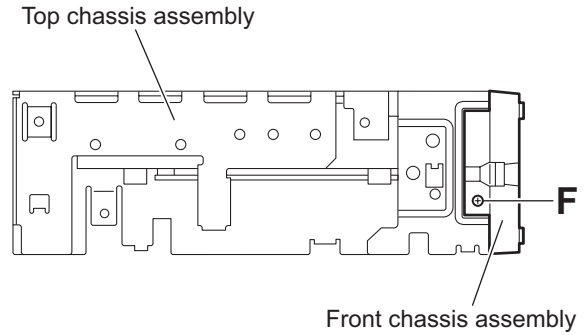

Fig.7

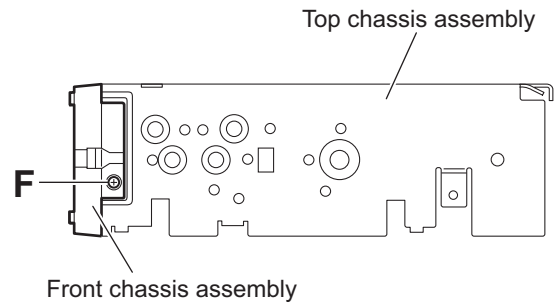

Fig.8

**3.1.5 Removing the CD mechanism assembly
(See Fig.9)**

- Prior to performing the following procedures, remove the front panel assembly, heat sink and top chassis assembly.

Reference:

Remove the front chassis assembly as required.

- (1) From the inside of the top chassis assembly, remove the three screws **G** attaching the CD mechanism assembly.
- (2) Release the mecha heat sink from the slots **a** on the mechanism control board and remove the heat sink from the main body.
- (3) Take out the CD mechanism assembly from the top chassis.

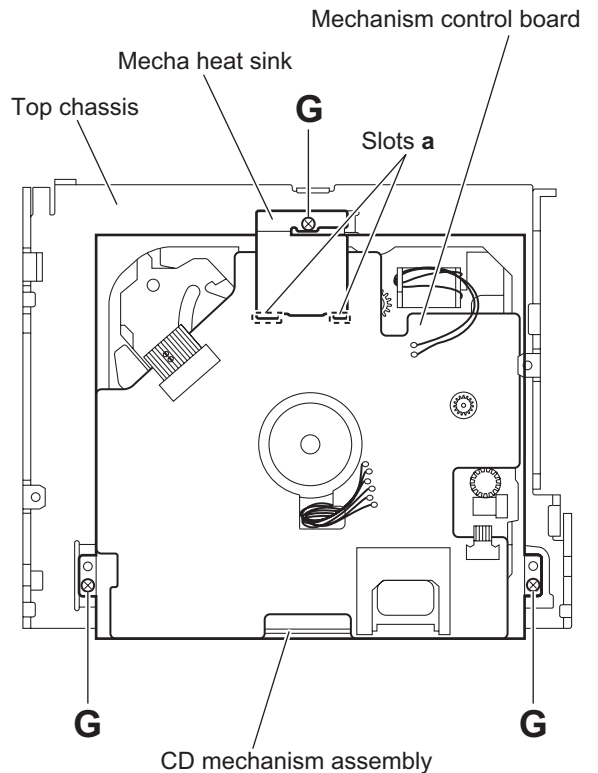

Fig.9

3.1.6 Removing the main board (See Figs.10 and 11)

- Prior to performing the following procedures, remove the front panel assembly, heat sink and top chassis assembly.
 - (1) From the rear side of the bottom chassis assembly, remove the two screws **H** attaching the rear bracket to the bottom chassis assembly. (See Fig.11)
 - (2) From the top side of the bottom chassis assembly, remove the two screws **J** attaching the main board to the bottom chassis assembly. (See Fig.11)
 - (3) Release the stopper of the connector [CN701](#) on the main board in an upward direction, disconnect the card wire from the connector [CN701](#). (See Fig.11)
 - (4) Disconnect the wire from the connector of the front door mechanism assembly. (See Fig.11)
 - (5) Disconnect the wire from the connector [CN991](#) on the main board. (See Fig.11)

Reference:

After connecting the wires, fix the wires with the wire holders.

- (6) Take out the main board from the bottom chassis assembly.

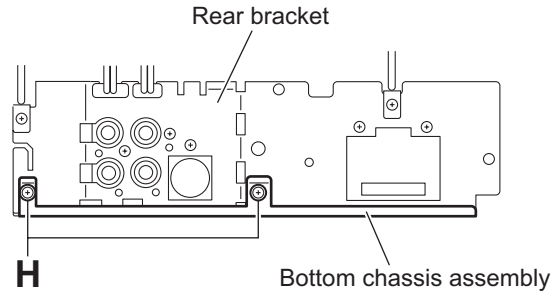

Fig.10

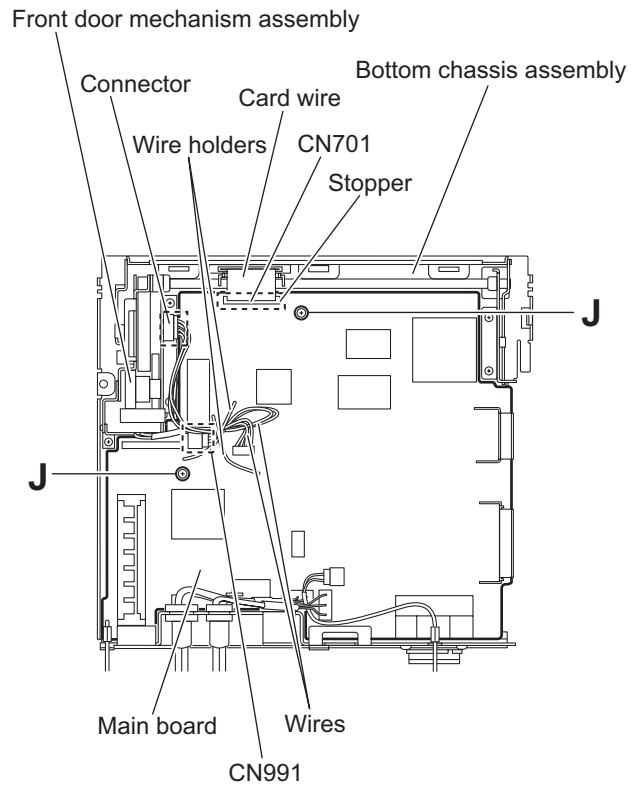

Fig.11

3.1.7 Removing the rear bracket
(See Fig.12)

- Prior to performing the following procedures, remove the front panel assembly, heat sink, top chassis assembly and main board.

- (1) From the rear side of the main board, remove the wires from the rear bracket in the direction of the arrow.
- (2) Remove the screw **K**, screw **L**, three screws **M** and screw **N** attaching the rear bracket to the main board.

Reference:

After attaching the rear bracket to the main board, pass the wires through the wire holder and insert them into the slots of the rear bracket.

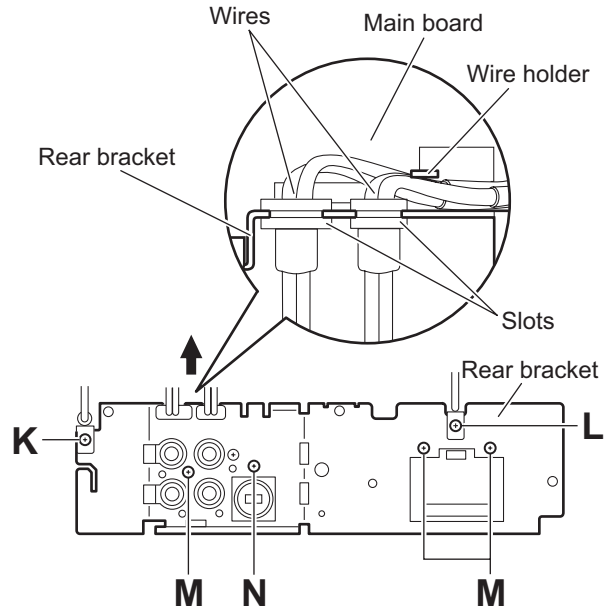

Fig.12

3.1.8 Removing the front door mechanism assembly
(See Fig.13)

- Prior to performing the following procedures, remove the front panel assembly, heat sink, top chassis assembly and main board.

- (1) From the top side of the bottom chassis assembly, remove the screw **P** attaching the FPC guide to the bottom chassis.
- (2) Remove the five screws **Q** attaching the front door mechanism assembly to the bottom chassis.

Reference:

When attaching the screws **P** and **Q**, apply a locking agent them.

- (3) Take out the front door mechanism assembly from the bottom chassis.

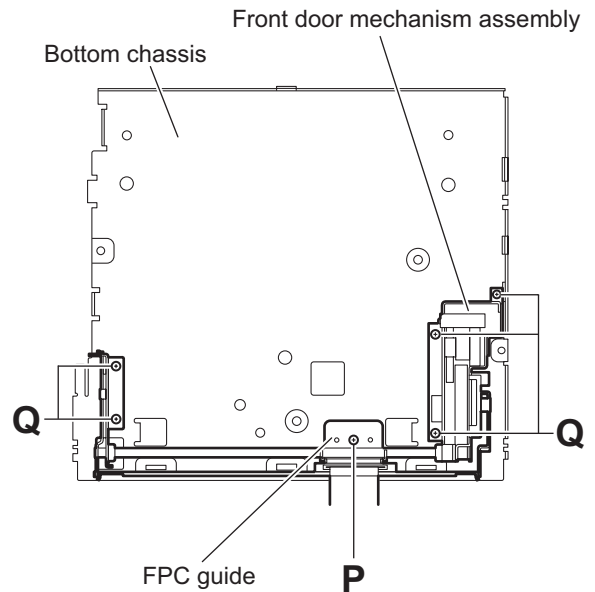

Fig.13

3.1.9 Removing the front board (See Figs.14 to 16)

- Prior to performing the following procedures, remove the front panel assembly.
 - (1) From the rear side of the front panel assembly, remove the four screws **R** attaching the rear cover to the front panel assembly. (See Fig.14)
 - (2) Release the twelve joints **b** of the front panel assembly and remove the rear cover. (See Fig.15.)
 - (3) Take out the front board from the front panel assembly. (See Fig.16)

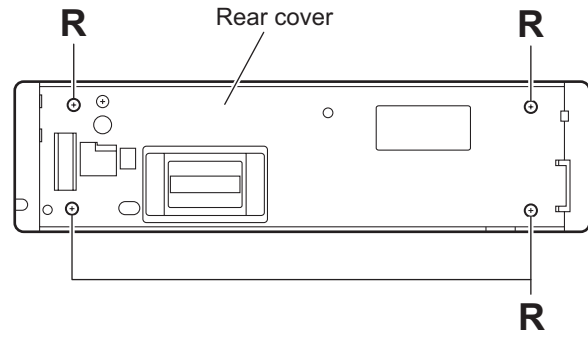

Fig.14

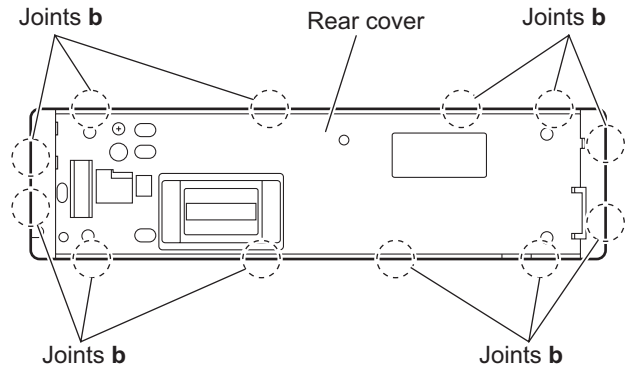

Fig.15

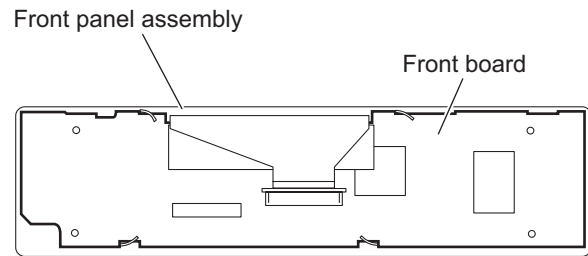

Fig.16

3.2 CD mechanism assembly section

- Remove the CD mechanism assembly from the main body.
(See "3.1.5 Removing the CD mechanism assembly".)

3.2.1 Removing the mechanism control board (See Fig.1)

- From the bottom side of the CD mechanism assembly, solder the short sections on the flexible wire.

Caution:

Solder the short sections on the flexible wire before disconnecting the flexible wire from the connector [CN601](#) on the mechanism control board. If you do not follow this instruction, the CD pickup may be damaged.

- Disconnect the flexible wire from the connector [CN601](#) on the mechanism control board.
- Disconnect the flexible wire from the connector [CN602](#) on the mechanism control board.
- Remove the solders from the soldered sections **a** on the mechanism control board and remove the wires of the feed motor.
- Remove the solders from the soldered sections **b** on the mechanism control board, and remove each wire of the spindle motor and other parts.
- Remove the five screws **A** attaching the mechanism control board.

Caution:

When reassembling, remove the solders from the short sections after connecting the flexible wire to the connector [CN601](#) on the mechanism control board.

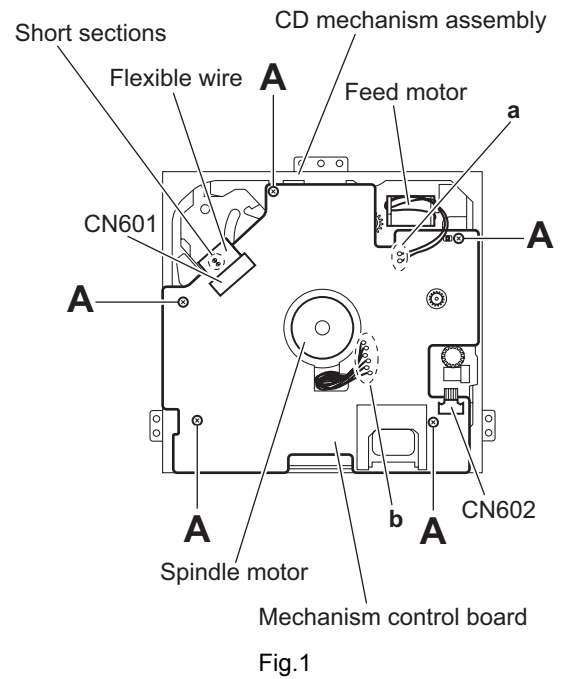

3.2.2 Removing the top cover (See Fig.2)

- (1) From the back side of the CD mechanism assembly, remove the two screws **B** attaching the top cover.
- (2) Take out the top cover in an upward direction.

Reference:

When attaching the top cover, set the sections **c** of the top cover under the bending sections **d** of the chassis base 2.

3.2.3 Removing the mechanism section (See Figs.2 to 4)

- Remove the mechanism control board and top cover.
 - (1) From the front side of the CD mechanism assembly, remove the two screws **C** attaching the right and left stoppers. (See Fig.2.)
 - (2) Remove the two floating springs on the bottom side of the CD mechanism assembly. (See Fig.3.)
 - (3) Take out the mechanism section in an upward direction and remove the three damper springs from the dampers. (See Fig.4.)

Caution:

- When reassembling the mechanism section, reattach the damper springs to the dampers respectively and insert the three shafts on the bottom of the mechanism section to the dampers. (See Fig.4.)
- Before inserting the shaft to the dampers, apply IPA to the hole of damper.

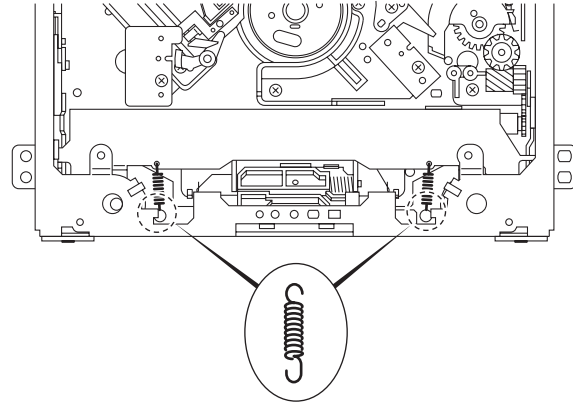

Floating spring

Fig.3

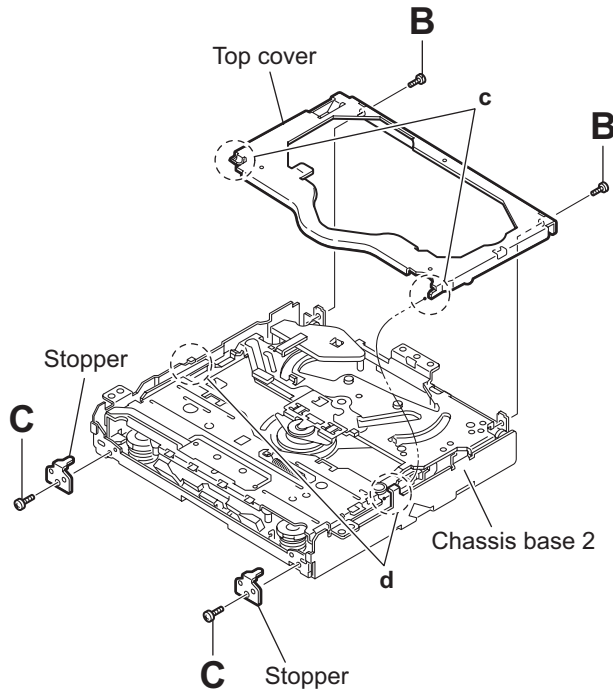

Fig.2

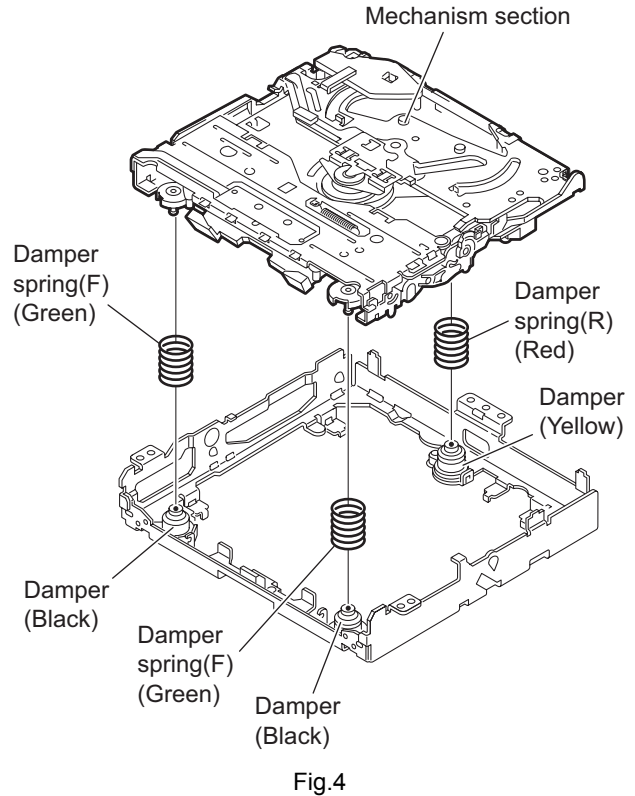

Fig.4

3.2.4 Removing the clamber unit (See Figs.5 and 6)

- Remove the mechanism control board, top cover and mechanism section.
 - From the bottom side of the mechanism section, remove the clamber 2 spring. (See Fig.5.)
 - Release section **e** of the clamber spring from the bending section of the CD chassis assembly. (See Fig.6.)
 - Move the clamber unit 2 in the direction of the arrow and release the joints (**f**, **g**). (See Fig.5.)
 - Take out the clamber unit 2 in an upward direction. (See Fig.5.)

3.2.5 Reattaching the clamber unit (See Figs.5 to 9)

- From the bottom side of the mechanism section, attach the clamber spring to the clamber unit 2. (See Figs.5 and 9.)
- Move the clamber unit 2 to set the joints (**f**, **g**) to each projection of the CD chassis assembly. (See Fig.5.)
- Make sure that section **h** of the clamber unit 2 is inserted to the notch of the CD chassis assembly. (See Figs.5 and 8.)
- Move the clamber spring to the outside of the bending part of the CD chassis assembly. (See Fig.6.)

Caution:

When reattaching the clamber unit 2, temporarily hook the end of the clamber spring as shown in the figure to make the work easy. (See Fig.9.)

- Attach the clamber 2 spring to the CD chassis assembly and clamber unit 2. (See Figs.5 and 7.)

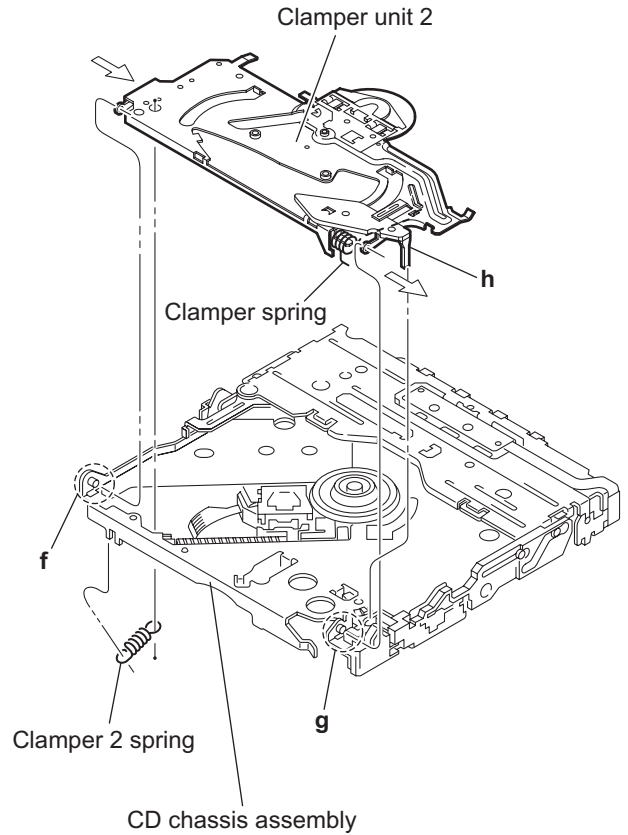

Fig.5

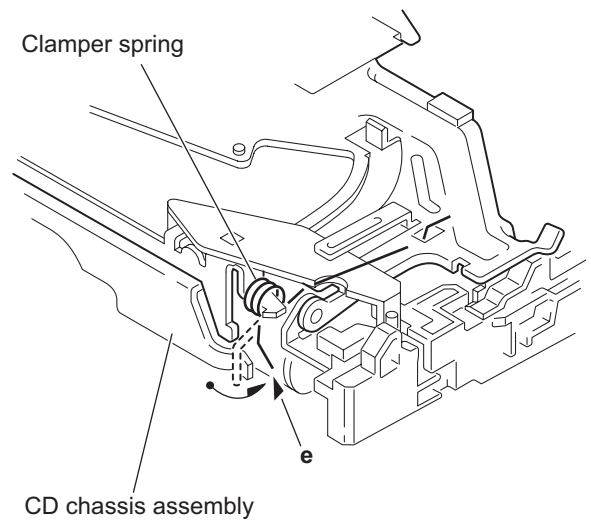

Fig.6

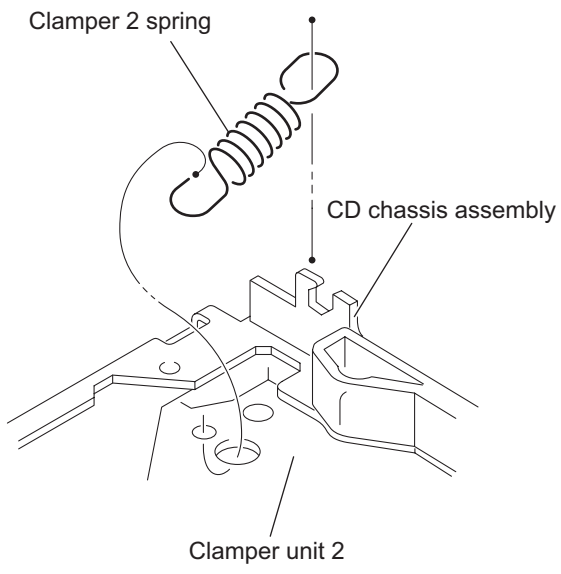

Fig.7

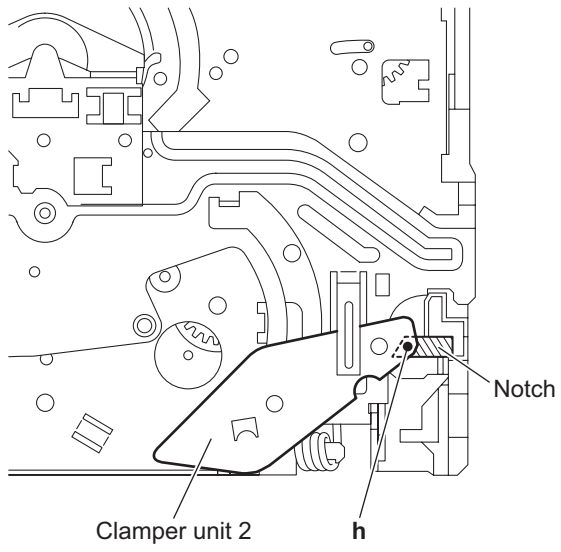

Fig.8

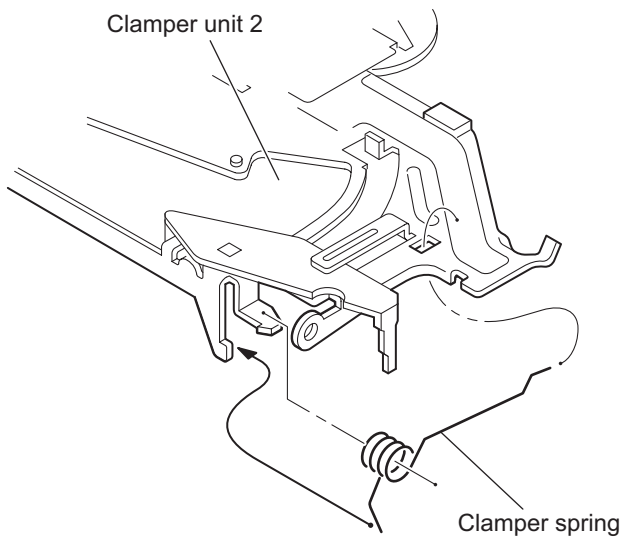

Fig.9

3.2.6 Removing the front unit (See Figs10 to 12)

- Remove the mechanism control board, top cover and mechanism section.
 - From the bottom side of the mechanism section, remove the double-stick tape fixing the flexible wire. (See Fig.10.)
 - From the top side of the mechanism section, remove the screw **D** attaching the front unit 2. (See Figs.11 and 12.)
 - Move the front unit 2 toward the front to release the joint **i**. (See Figs.11 and 12.)
 - Release two joints **j** and **k** on the right side of the CD chassis assembly. (See Fig.12.)
 - Take out the front unit 2 in an upward direction.
 - Remove the double-stick tape fixing the flexible wire and remove the two screws **E** attaching the switch wire. (See Fig.12.)

Reference:

You can remove the switch wire only without removing the front unit 2.

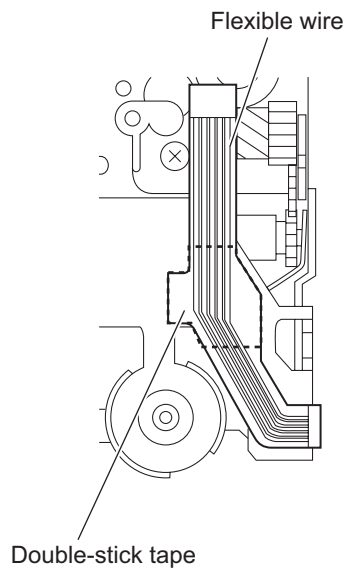

Fig.10

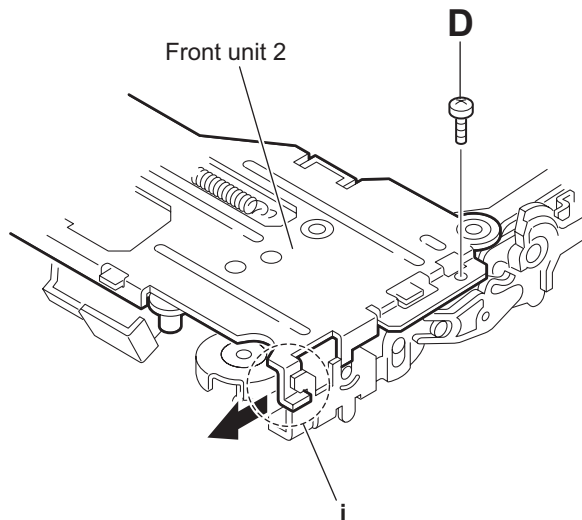

Fig.11

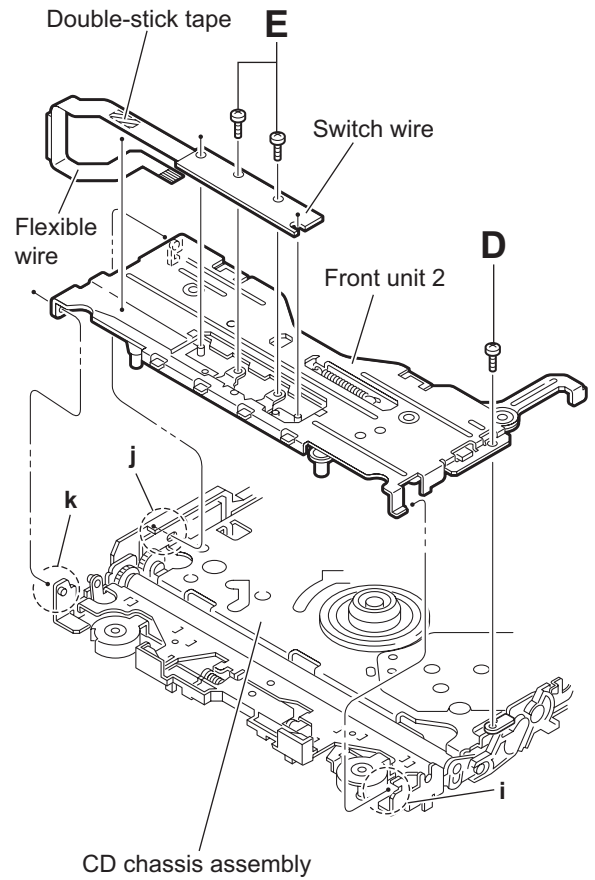

Fig.12

3.2.7 Removing the loading arm assembly (See Figs.13 and 14)

- Remove the mechanism control board, top cover, mechanism section and front unit 2.
 - From top side of the mechanism section, move the loading arm assembly in the direction of the arrow. (See Fig.13.)
 - Release the projections from the right and left joints (**m**, **n**) of the CD chassis assembly. (See Figs.13 and 14.)
 - Release the projection from notch **p** of the connect arm on the right side of the mechanism section and release the projection from notch **q** of the slide cam assembly on the left side. (See Figs.13 and 14.)

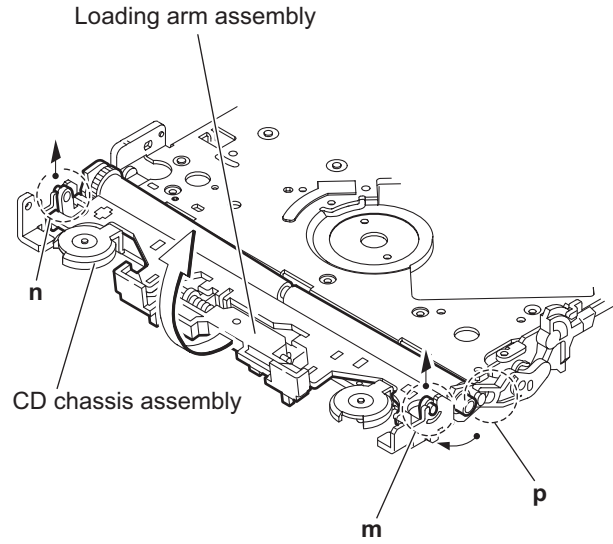

Fig.13

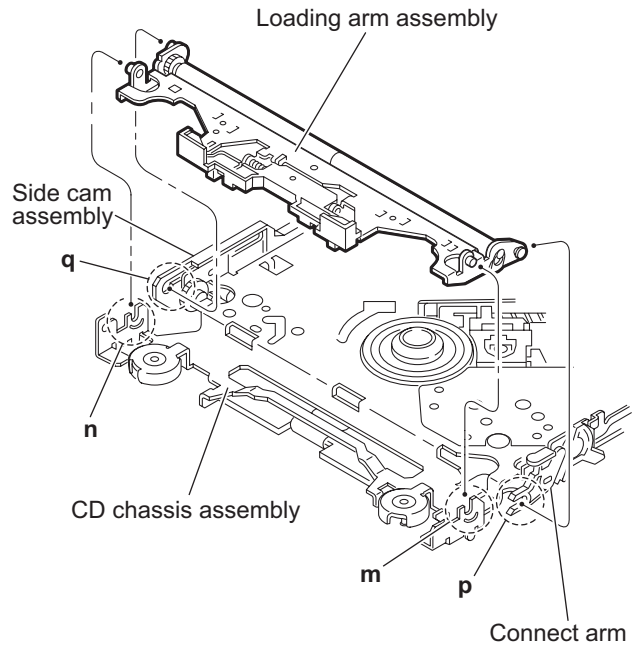

Fig.14

3.2.8 Removing the rod (L), rod (R) and roller assembly (See Figs.15 and 16)

- Remove the mechanism control board, top cover, mechanism section, front unit and loading arm assembly.
 - From the bottom side of the loading arm assembly, release the rod (L) and (R) from the joints *r*. (See Fig.15.)
 - Remove the roller assembly from the loading arm assembly. (See Fig.16.)
 - Remove the two collars and washer from the roller assembly. (See Fig.16.)

Caution:

After attaching the roller assembly to the loading arm assembly, attach the rod (L) and (R). Then attach the rods to the right and left collars of the roller assembly. (See Fig.15.)

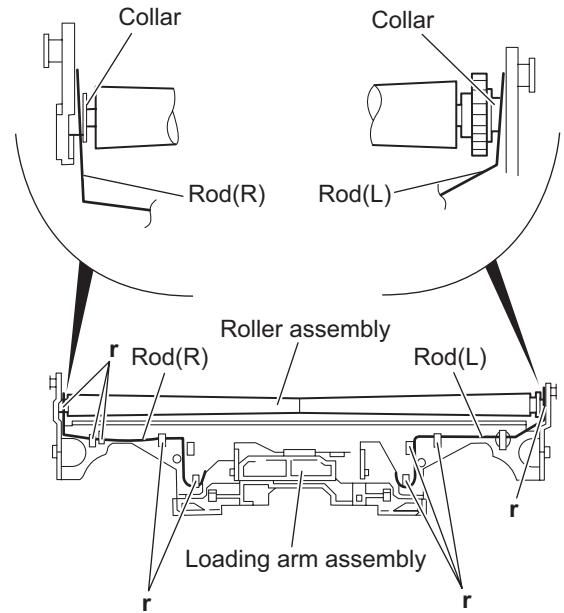

Fig.15

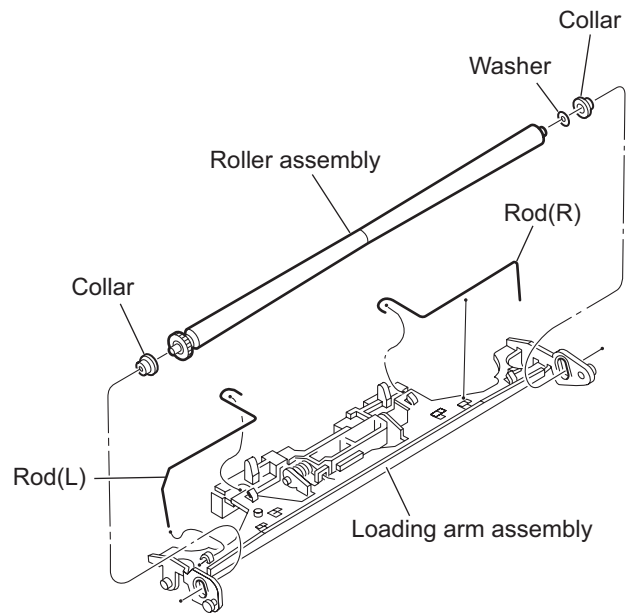

Fig.16

3.2.9 Removing the CD pickup (See Figs.17 to 19)

- Remove the mechanism control board.
 - (1) From the bottom side of the CD mechanism assembly, turn the feed gear in the direction of the arrow to move the CD pickup assembly outwards. (See Fig.17.)
 - (2) Remove the screw **F** and remove the thrust spring. (See Fig.17.)
 - (3) Remove the CD pickup assembly in an upward direction from the side of L.S. gear and release the CD pickup assembly from joint **s** of the sub guide. (See Fig.18.)
 - (4) Move the lead screw of the CD pickup assembly in the direction of the arrow to release at joint **t**. (See Fig.18.)
 - (5) Remove the screw **G** attaching the CD rack spring and CD rack plate on the CD pickup assembly. (See Fig.19.)
 - (6) Pull out the lead screw. (See Fig.19.)

Caution:

- When attaching the CD pickup assembly, attach the CD pickup assembly at joint **s** of sub guide first, and attach the lead screw to the joint **t** on the L.S.holder 2. (See Fig.18.)
- Perform electric adjustment after replacing the pickup.

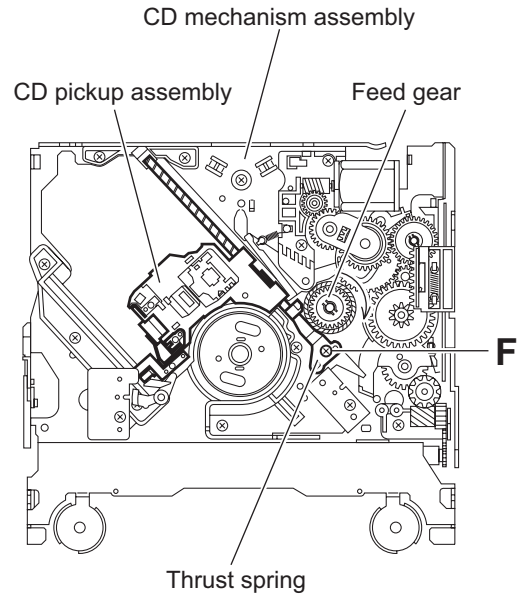

Fig.17

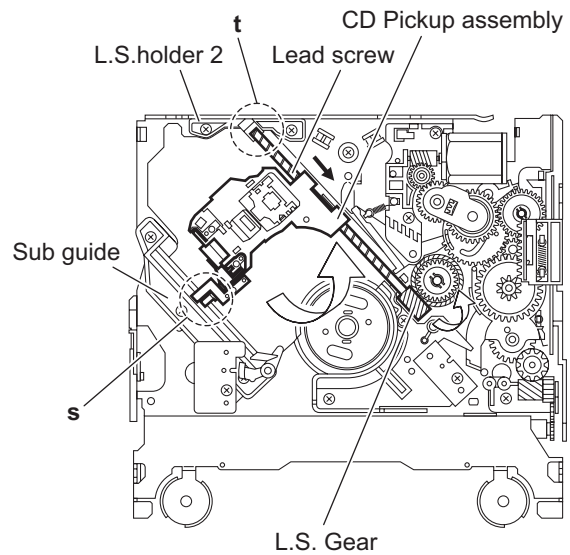

Fig.18

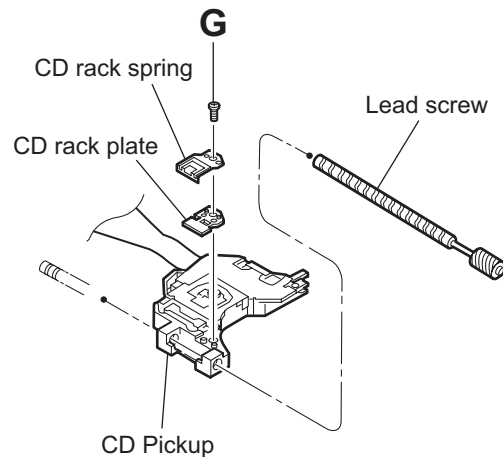

Fig.19

3.2.10 Removing the spindle motor (See Fig.20)

- Remove the mechanism control board, top cover, mechanism section and clamber unit.
 - From the top side of the mechanism section, remove the T.table assembly and washer from the spindle motor.
 - Remove the two screws **H** attaching the spindle motor.
 - Take out the spindle motor from the bottom side of the mechanism section.

Caution:

Perform adjustment when reattaching the spindle motor.

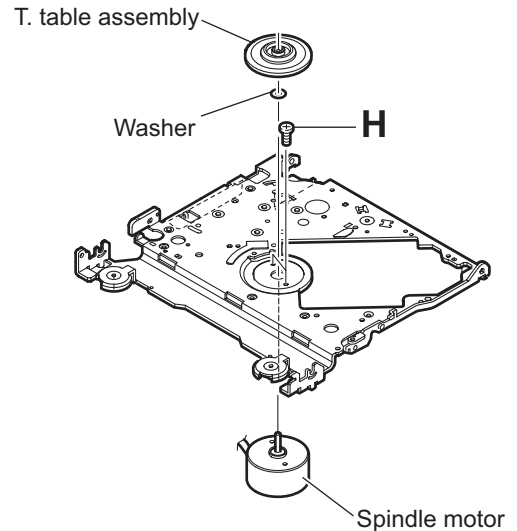

Fig.20

3.2.11 Removing the feed motor (See Figs.21 and 22)

- Remove the mechanism control board.
 - From the bottom side of the CD mechanism assembly, remove the feed TRI. spring. (See Fig.21.)
 - Remove the two screws **J** attaching the feed motor assembly. (See Fig.21.)
 - Remove the slit washer from the motor H. assembly and pull out the worm wheel. (See Fig.22.)
 - Remove the two screws **K** attaching the feed motor. (See Fig.22.)

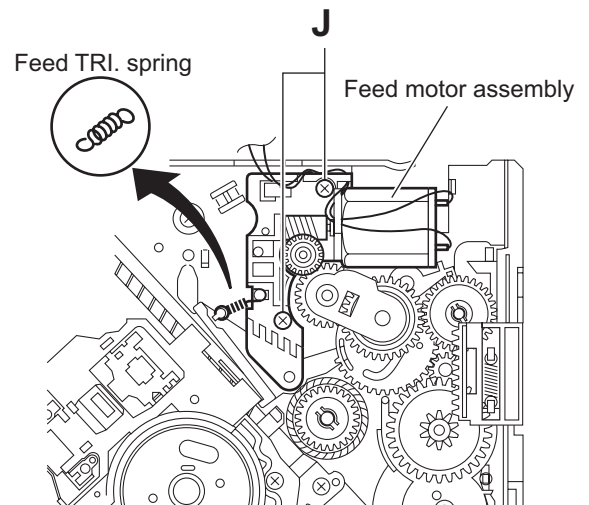

Fig.21

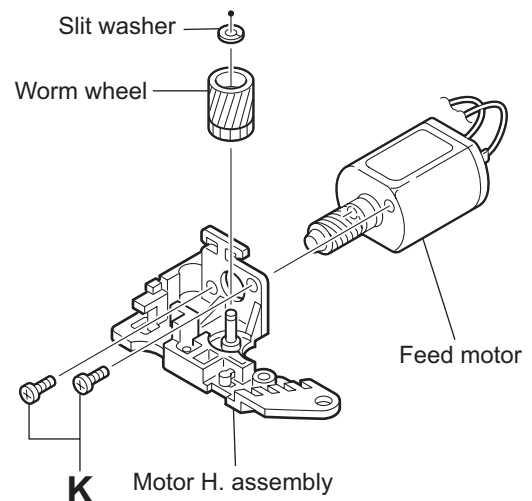

Fig.22

3.2.12 Removing the SW board and rest SW board (See Fig.23)

- Remove the mechanism control board.
 - From the bottom side of the CD mechanism assembly, remove the screw **L** attaching the SW board.
 - Remove the screw **M** attaching the rest SW board.

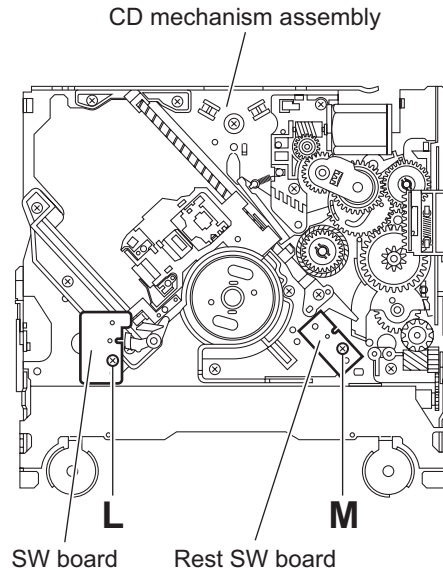

Fig.23

SECTION 4 ADJUSTMENT

4.1 Adjustment method

■ Test instruments required for adjustment

- (1) Digital oscilloscope (100MHz)
- (2) Electric voltmeter
- (3) Digital tester
- (4) Tracking offset meter
- (5) Test Disc JVC :CTS-1000
- (6) Extension cable for check
EXTDV001-20P × 1

■ Standard volume position

Balance and Bass & Treble volume : Indication "0"
Loudness : OFF

■ How to connect the extension cable for adjusting

Caution:

Be sure to attach the heat sink and rear bracket onto the power amplifier IC and regulator IC respectively, before supply the power. If voltage is applied without attaching these parts, the power amplifier IC and regulator IC will be destroyed by heat.

■ Standard measuring conditions

Power supply voltage	DC14.4V(11 to 16V)
Load impedance	20K Ω (2 Speakers connection)
Output Level	Line out 5.0V (Vol. MAX)

■ Dummy load

Exclusive dummy load should be used for AM, and FM. For FM dummy load, there is a loss of 6dB between SSG output and antenna input. The loss of 6dB need not be considered since direct reading of figures are applied in this working standard.

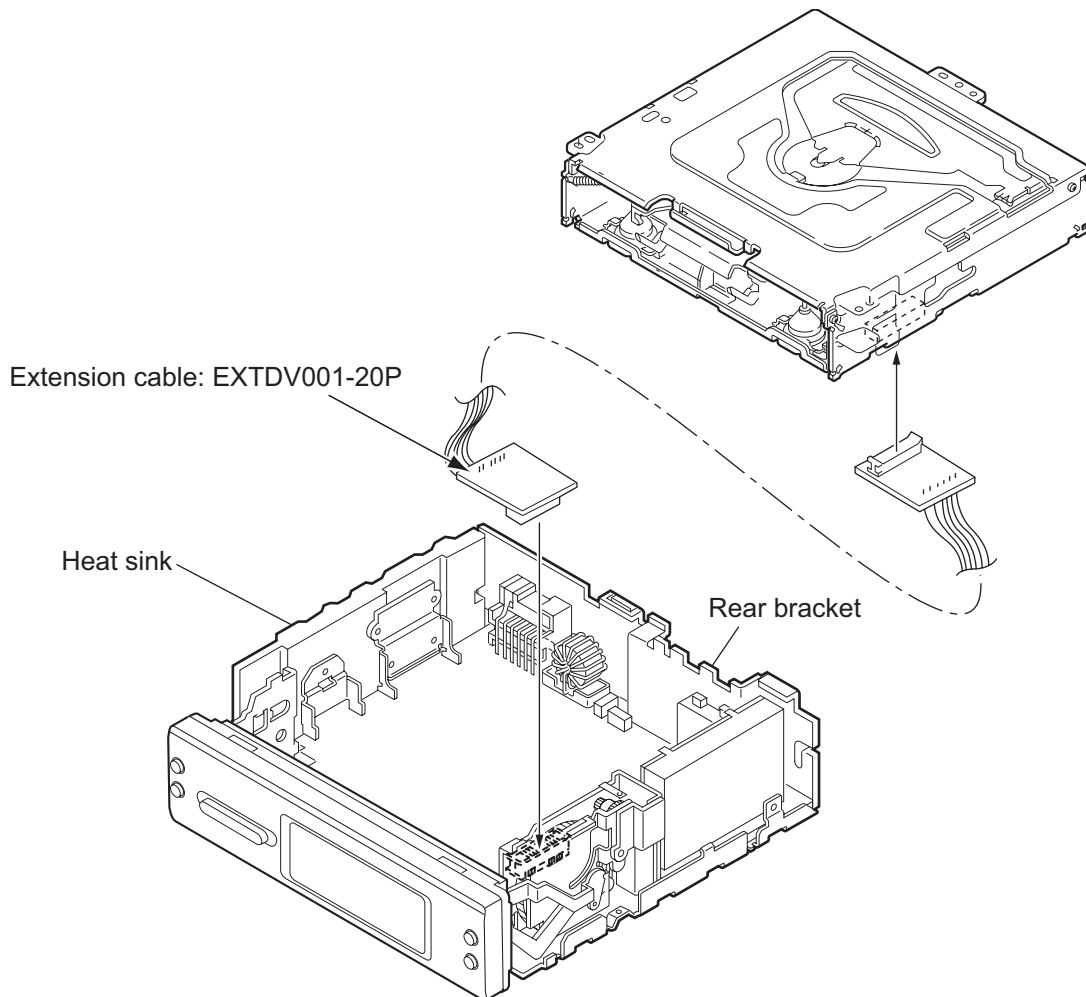

4.2 Service mode

4.2.1 Service mode setting

- (1) Push POWER BOTTON (Power ON)
- (2) Set to service mode
By pushing and holding "DISP" + "VOLUME +" + touch panel "upper right" sequentially.

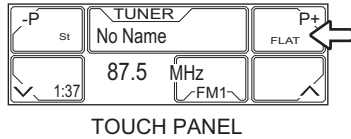
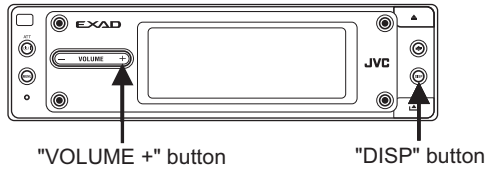

SERVICE MODE3 (MENU)

PRODUCT MODE	SERVICE MODE	RUNNING MODE	DATA CLEAR
DSP TUNER S MODE	DSP TUNER Adjust	VOICE CHECK	BACK

1	2	3	4
5	6	7	8

SERVICE MODE (MENU)

2

VERSION	CD DATA READ	ERR READ	
ROM COLLE	NON		BACK

VERSION

VERSION	X ****	Y ***	V □□□	V □□□	BACK
MAIN	■ ■ ■ ■	DSP	■ ■ ■ ■		
CD V	■ ■ ■ ■				
CH V	■ ■ ■ ■				

·Version display
 *... Terminal AD value
 □... Panel microcom version display
 ■... Display ROM version display

CD DATA READ (MENU)

ADJ NOW	ADJ INIT	OTHERS	
			BACK

CD ERROR READ (MENU)

CD ERR	CH ERR	MECHA ERR	
TDSP ERR			BACK

CD ERROR

CD ERR					
E1	*****	2	*****		
E2	*****	3	*****		
E3	*****	4	*****		
1	*****	5	*****		
					BACK

CD error display
 *... Display by error code chart

CH ERROR

CH ERR					
E1	*****	2	*****		
E2	*****	3	*****		
E3	*****	4	*****		
1	*****	5	*****		
					BACK

CD changer error display
 *... Display by error code chart

MECHA ERROR

MECHA ERR					
E1	*****	2	*****		
E2	*****	3	*****		
E3	*****	4	*****		
1	*****	5	*****		
					BACK

·Door mecha error display
 *... Display by error code chart

DSP TUNER ERROR

TDSP ERROR					
RETRY	NG	TOTAL	***		
		TOTAL	***		
					BACK

·DSP tuner error display
 *... The number of times of the communication error at the time of Power ON is displayed.

(A)

(B)

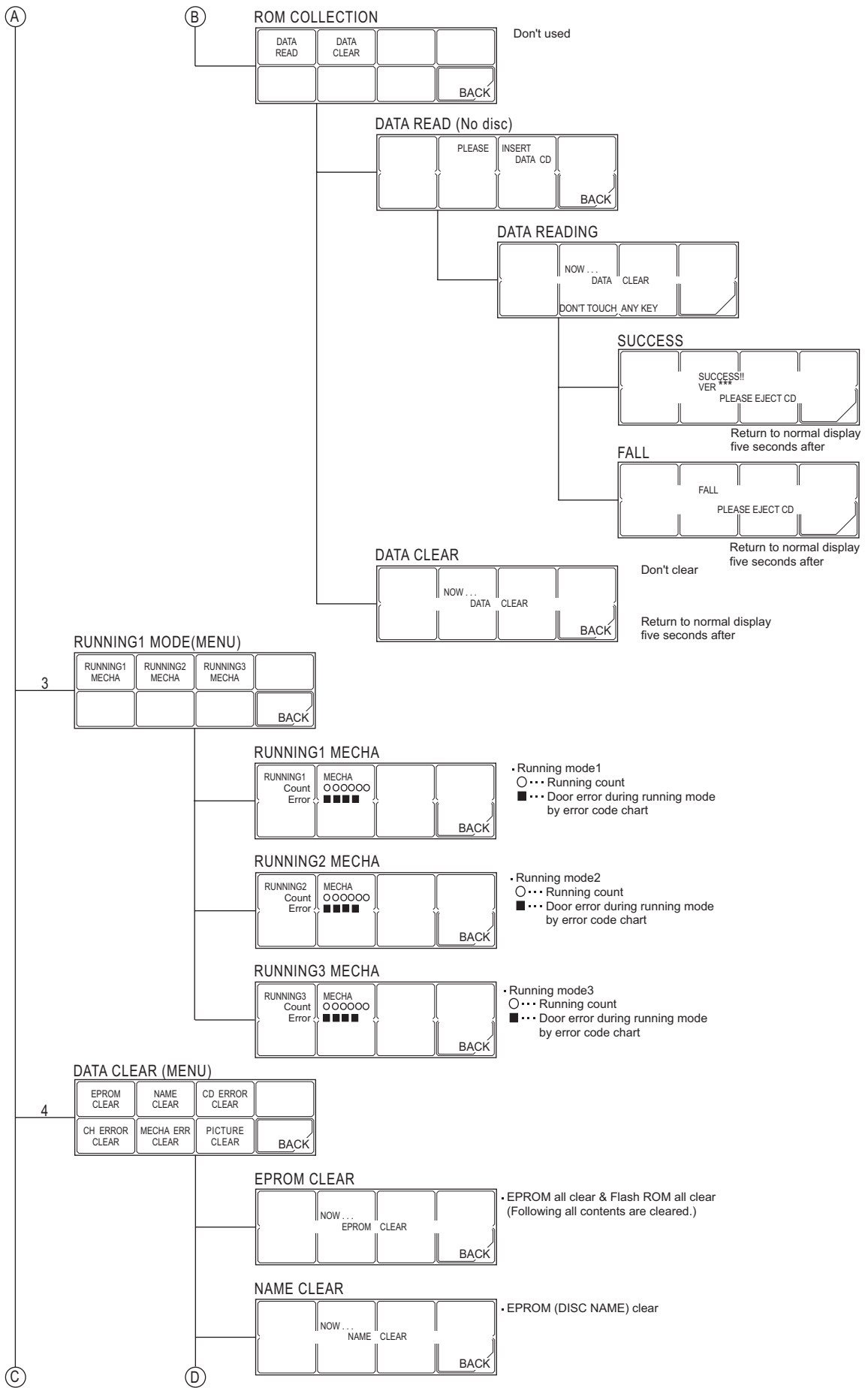

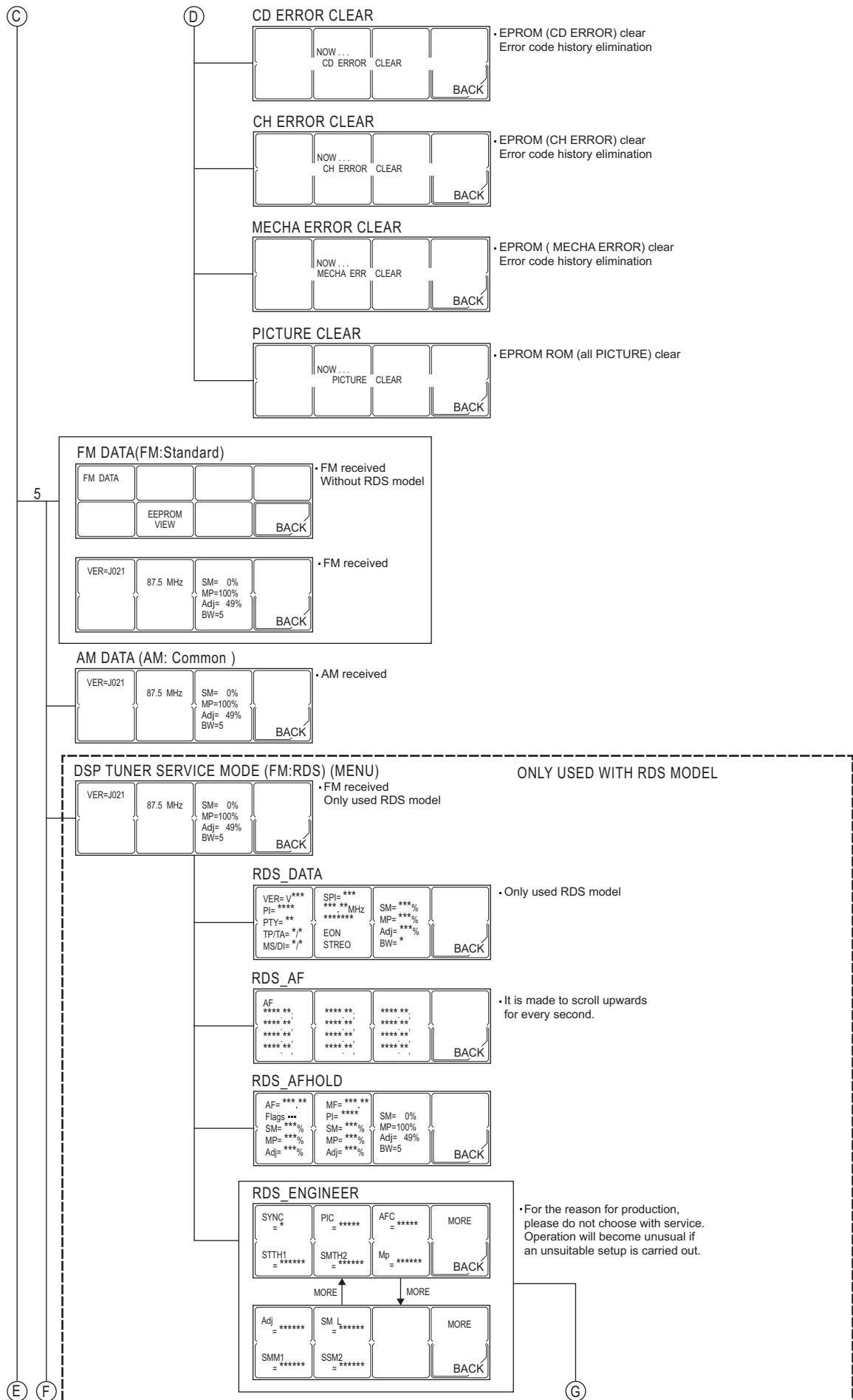

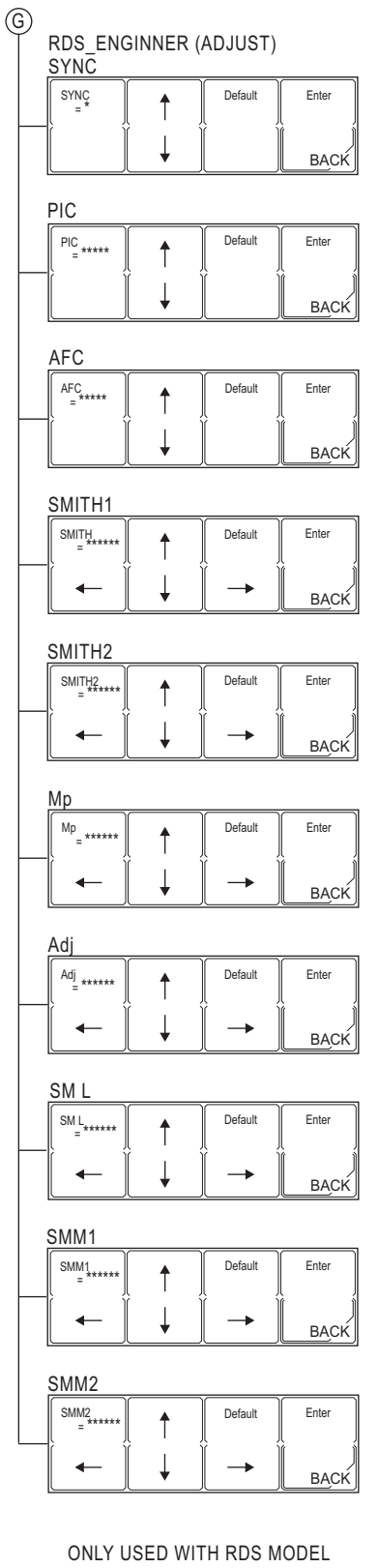
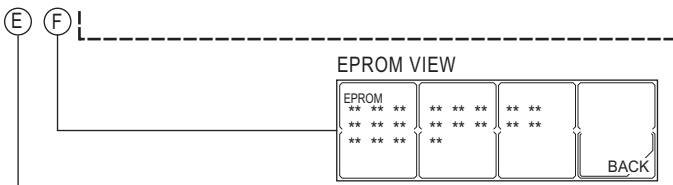

H

H

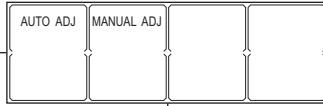

AUTO ADJ

It is not used for the item used inside at the time of manufacture.

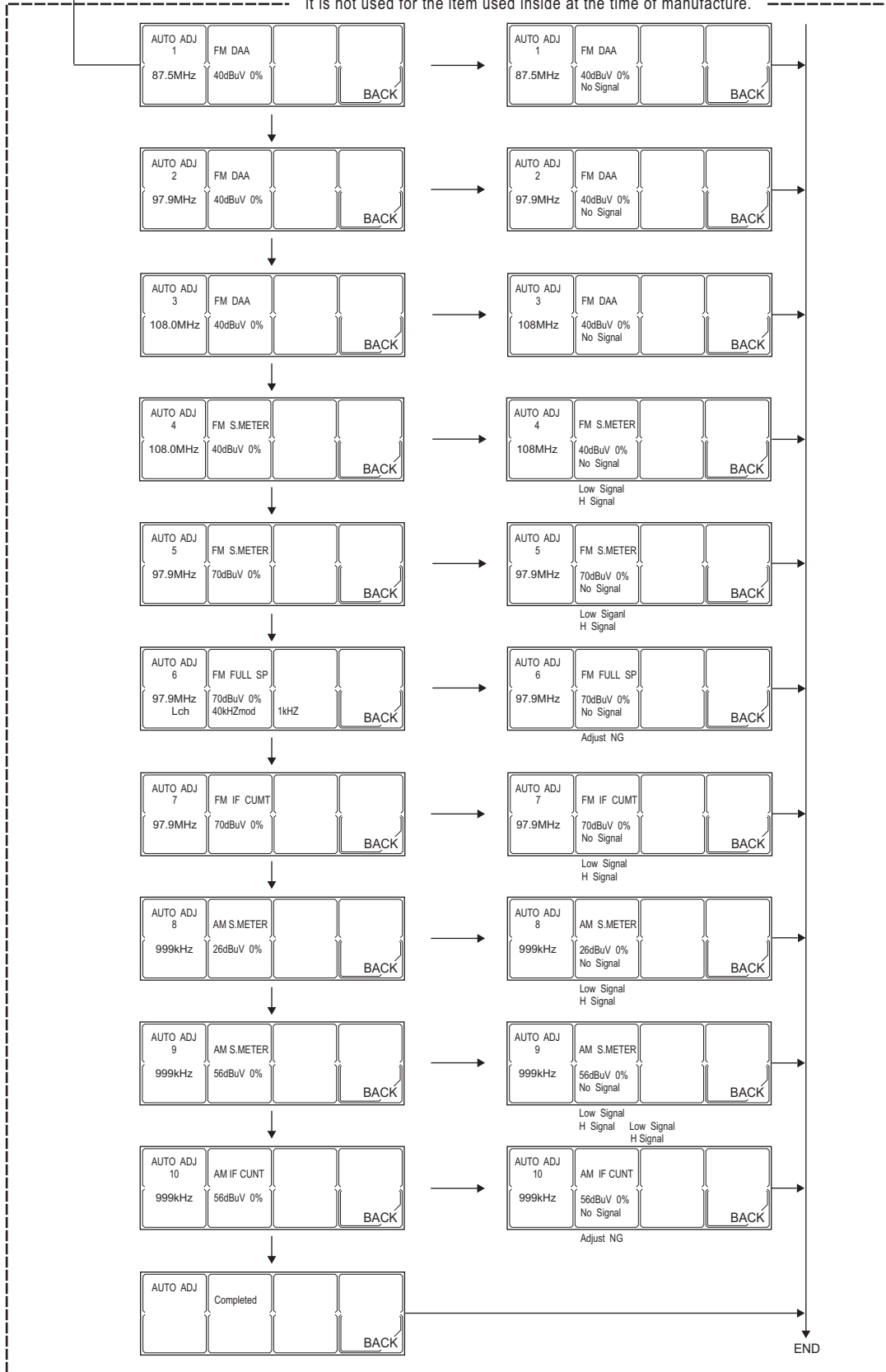

END

J

MANUAL ADJ

It will be used if there are directions.

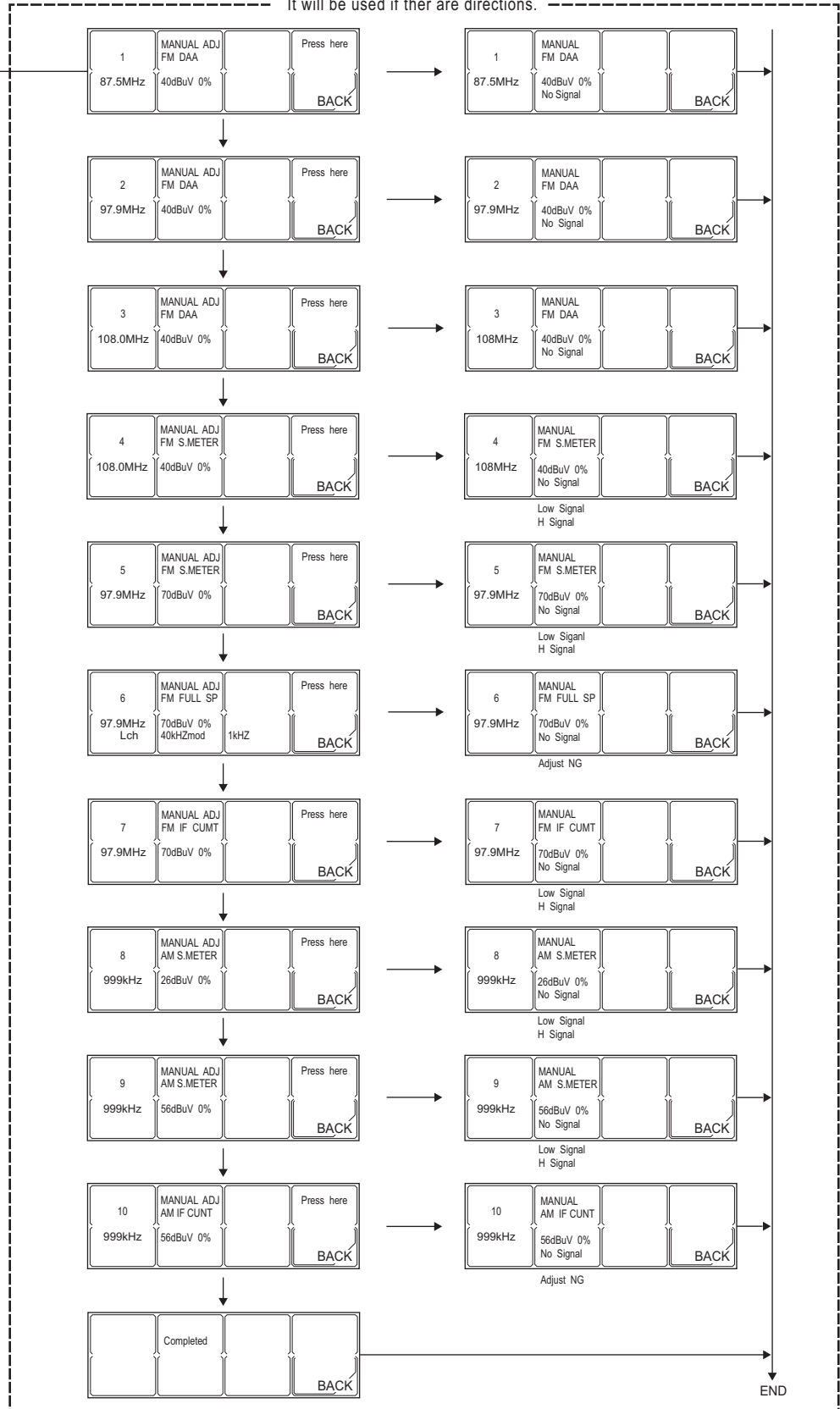

4.2.2 Detailed CD error code

Error	Details of error	Error code	Detailed error code
Pickup movement error	Time over at PUBWD and PUFWD by monitoring RESET SW		
1.Time over of pickup movement in an inner direction(10s)	Pickup cannot move in an inner direction.RESET SW is not on	04	0051
2.Time over of pickup movement in an outer direction(10s)	Pickup cannot move in an outer direction.RESET SW is not off	04	0052
Focus serch error Focus is not adjusted by 3-round focus serch	When focus is not adjusted by 3-round(1set) focus serch after disc change or focus shock, the result is NG	81	0053
Tracking balance adjustment error Time over(1s)	Tracking balance adjustment is not finished 1s after adjustment command(TBA) is executed	82	0054
TOC area search error Time over(10s)	TOC area search is not finished after 10s	80	0055
Focus balance adjustment error Time over(2s)	Focus balance adjustment is not finished 2s after the adjustment command(FBA) is executed	82	0056
Focus gain adjustment error Time over(0.6s)	Foucus gain adjustment error is not finished 0.6s after the adjustment command(FGA) is executed	82	0057
Tracking gain adjustment error Time over(0.6s)	Tracking gain adjustment error is not finished 0.6s after the adjustment command(TGA) is executed	82	0058
TOC read error Time over(30s)	TOC read operation is not finished after 30s	84	0059
1st track access error Time over(10s)	1st track access is not finished 10s after TOC reading is finished	80	0060
Last track access error Time over(10s)	Last track access is not finished 10s after 1st track in running mode	80	0061
Q code read error Time over(0.6s)	Q code is not read for 0.6s during playback of TOC and program area	80	0062
TEXT data read error	ALL TEXT data are not read	80	0063
RF read error	RF is not read RFOK is recognized as L	81	0064
SPT analysis error	SPT processing is not finished within the timer	84	0065
	SPT analysis is not successful	84	0066
FAT analysis error	FAT processing is not finished within the timer	84	0067
	FAT analysis is not successful	84	0068

4.2.3 Detailed error code of mechanism error





Error	Details of error	Error code	Detailed error code
Disc loading error 1.B1 Time out 2.B2 Time out 3.C1 Time out 4.C2 Time out 5.D1 Time out 6.D2 Time out 7.E1 Time out		09 09 09 09 09 09 09	0011 0012 0013 0014 0015 0016 0017
Eject error 1.B1 Time out 2.C2 Time out 3.D2 Time out 4.E2 Time out 5.F1 Time out		01 01 01 01 01	0021 0022 0023 0024 0025
Error while waiting for loading 1.While waiting for loading for 15 seconds, SW1 becomes L before stating loading motor	When a disc is removed	09	0031

4.2.4 Changer mechanism error display

Symptom	Details	Error code	Detailed error code
Tray eject error 1. TRAYINSW TIME OVER (TRAYINSW:L, TRAYOUTSW:H) 2. TRAYOUTSW TIME OVER (TRAYINSW:H, TRAYOUTSW:H) 3. TRAYINSW TIME OVER (TRAYINSW:L, TRAYOUTSW:L) 4. MAGIN SW:L→H	Tray motor TIME OVER Tray motor does not operate.	03	0011
	Tray stops.	03	0012
	TRAYINSW NG etc.	03	0013
	Magazine is ejected while Tray is being ejected.	03	0014
Tray return error 1. TRAYOUTSW TIME OVER (TRAYINSW:H, TRAYOUTSW:L) 2. TRAYINSW TIME OVER (TRAYINSW:H, TRAYOUTSW:H) 3. TRAYIN/OUTSW TIME OVER (TRAYINSW:L, TRAYOUTSW:L) 4. MAGIN SW:L→H	Tray motor TIME OVER Tray motor does not operate.	03	0016
	Tray stops.	03	0017
	TRAYOUTSW NG etc	03	0018
	Magazine is ejected while Tray is being returned.	03	0019
Lifter up error 1. WAIT position TIME OVER 2. WAIT position TIME OVER 3. WAIT position TIME OVER	Position motor TIME OVER Position motor does not operate.	02	0021
	Position is not stable in fine adjustment mode.	02	0022
	Other condition	02	0023
Lifter down error 1. WAIT position TIME OVER 2. WAIT position TIME OVER 3. WAIT position TIME OVER	Position motor TIME OVER Position motor does not operate.	02	0026
	Position is not stable in fine adjustment mode.	02	0027
	Other condition	02	0028
Chucking error 1. PLAY position TIME OVER 2. PLAY position TIME OVER 3. PLAY position TIME OVER	Position motor TIME OVER Position motor does not operate.	02	0031
	Position is not stable in fine adjustment mode.	02	0032
	Other condition	02	0033
Unchucking error 1. WAIT position TIME OVER 2. WAIT position TIME OVER 3. WAIT position TIME OVER	Position motor TIME OVER Position motor does not operate.	02	0036
	Position is not stable in fine adjustment mode.	02	0037
	Other condition	02	0038
EJECT error 1. EJECT position TIME OVER 2. EJECT position TIME OVER 3. MAGINSW TIME OVER	EJECT cannot be carried out. Position motor does not operate.	02	0041
	Improper EJECT position.*	02	0042
	Magazine is not ejected.	01	0043
Initialize error 1. Mechanism SW NG error 2. Absolute position TIME OVER	TRAYINSW and TRAYOUTSW are L.	03	0046
	Position is not stable in absolute position.*	02	0047

**Position is not stable in WAIT position," "Position is not stable in PLAY position," and "Position is not stable in absolute position," and "Improper EJECT position" are all Position Motor TIME OVER.

4.2.5 Error codes of panel mechanism

Angle	Panel	Condition
1	CLOSE	 BODY
2	10°	 10°
3	20°	 20°
4	30°	 30°
OPEN	OPEN	

Error	Error display in service mode	Error display in normal condition
Error in OPEN (Abnormal OPEN) 1. OPEN cannot be detected. TIME OUT	0A01	ERR 01
Error in CLOSE (Abnormal ANGLE1) 1. ANGLE 1 cannot be detected. TIME OUT	0B06	06
Error in angle adjustment Movement to angle 10° (Abnormal ANGLE2) 1. ANGLE 2 cannot be detected in movement in OPEN direction. TIME OUT 2. ANGLE 1 is passed and ANGLE 2 is detected in movement in OPEN direction. 3. ANGLE 2 cannot be detected in movement in CLOSE direction. TIME OUT	0D21 0D22 0D23	21 22 23
Movement to angle 20° (Abnormal ANGLE3) 1. ANGLE 3 cannot be detected in movement in OPEN direction. TIME OUT 2. ANGLE 2 is passed and ANGLE 3 is detected in movement in OPEN direction. 3. ANGLE 3 cannot be detected in movement in CLOSE direction. TIME OUT	0E31 0E32 0E33	31 32 33
Movement to angle 30° (Abnormal ANGLE4) 1. ANGLE 4 cannot be detected in movement in OPEN direction. TIME OUT 2. ANGLE 3 is passed and OPEN position is detected in movement in OPEN direction. 3. ANGLE 4 cannot be detected in movement in CLOSE direction. TIME OUT	0F41 0F42 0F43	41 42 43
Abnormal SW condition in panel movement When a panel is moved in a range from OPEN to CLOSE, ERR 00 is displayed when improper SW condition is detected.	0A00	00

4.2.6 Error history

Indication	Details
E1**????	Last error
E2**????	Second last error
E3**????	Third last error
5_**????	Fifth error
4_**????	Fourth error
3_**????	Third error
2_**????	Second error
1_**????	First error
TOTAL_??	Total amount of errors (100 errors or more is displayed as99)

SECTION 5 TROUBLESHOOTING

5.1 Feed section

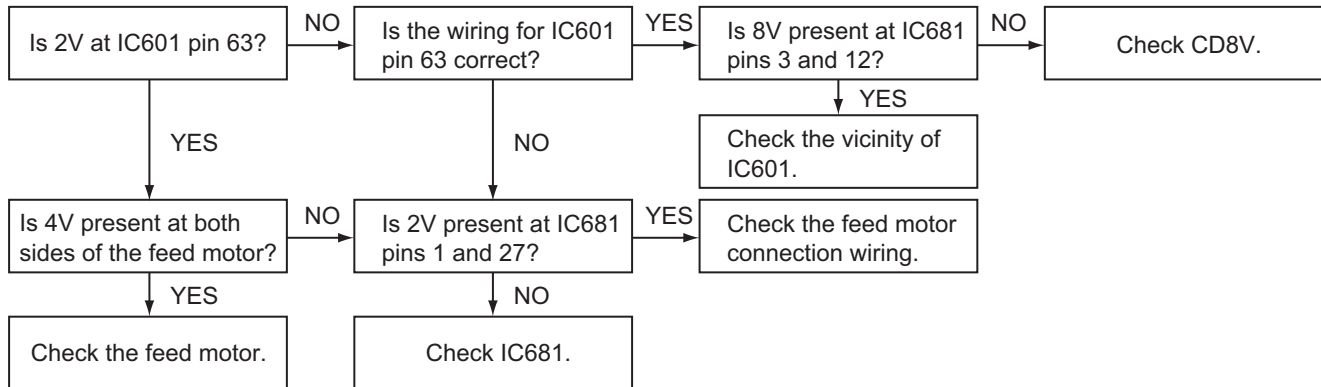

5.2 Focus section

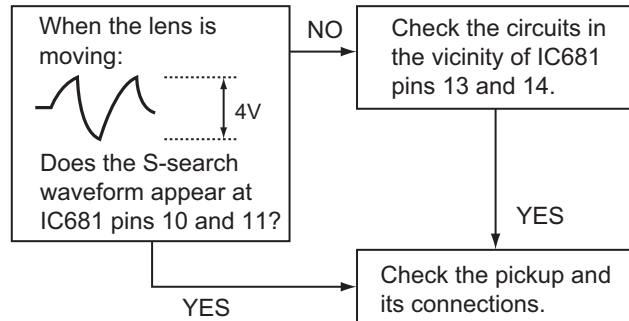

5.3 Spindle section

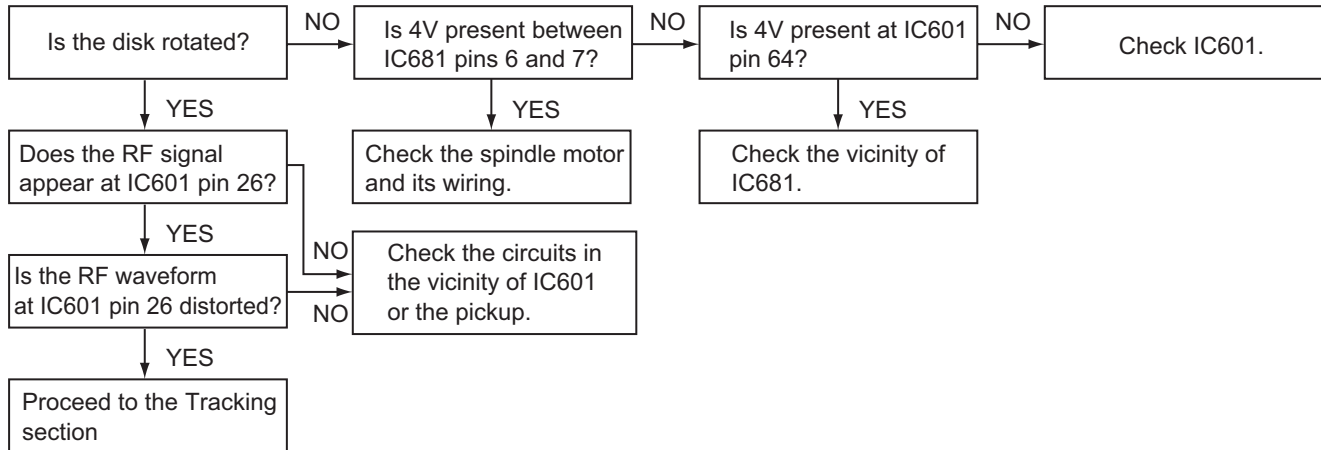

5.4 Tracking section

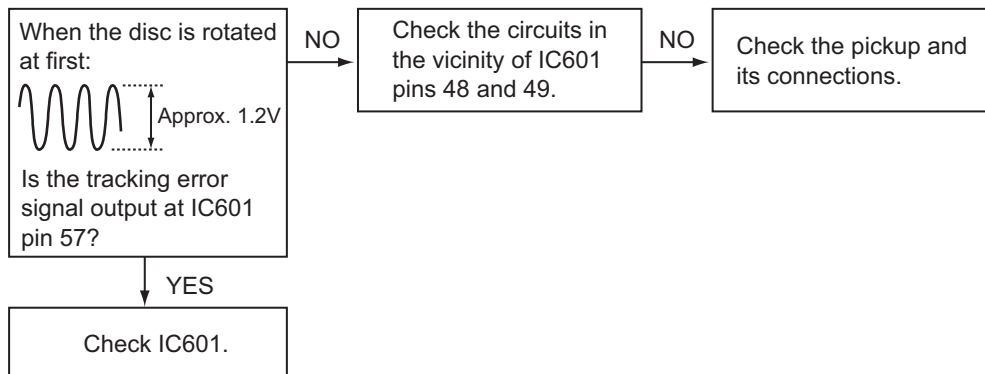

5.5 Signal processing section

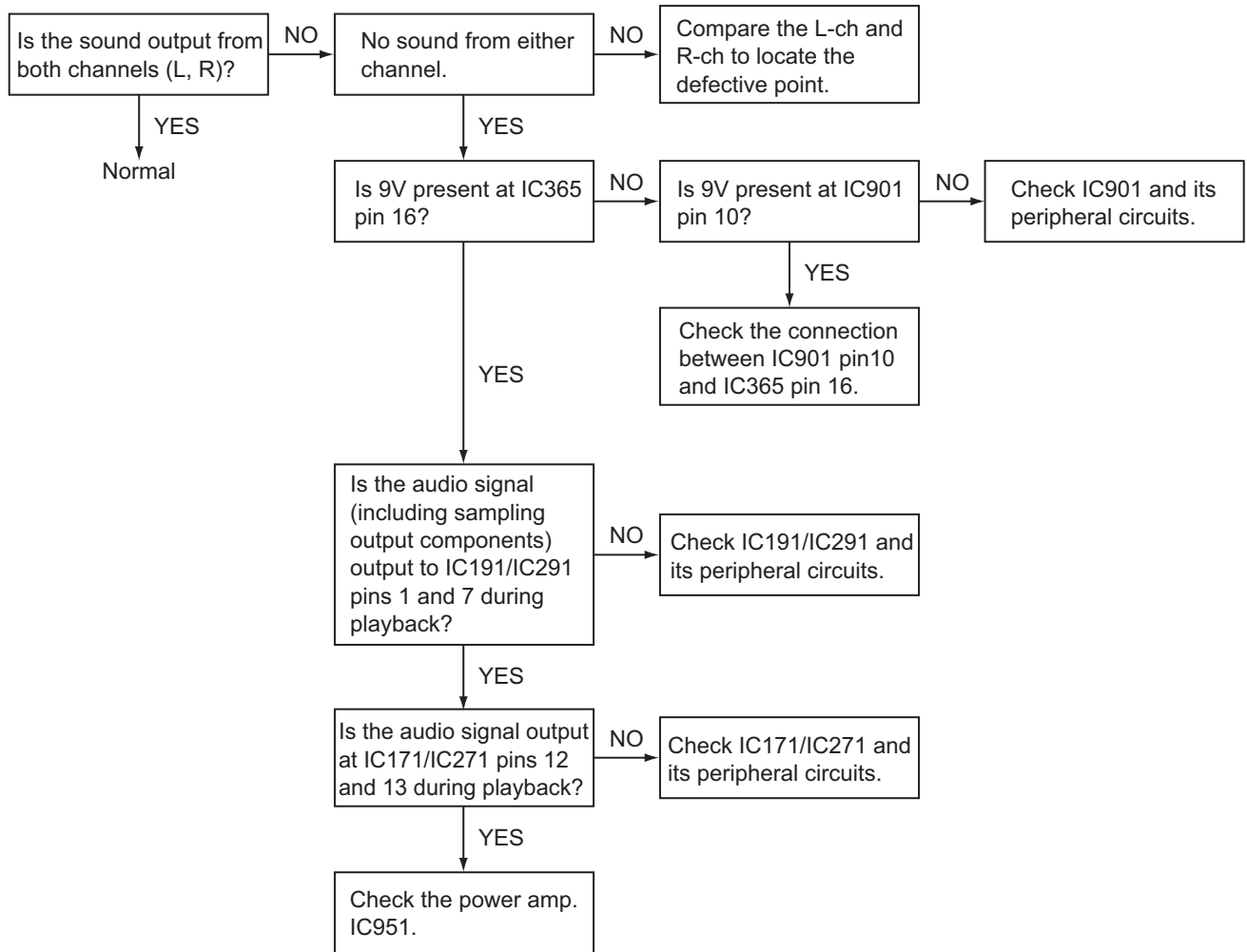

5.6 16 PIN CORD DIAGRAM

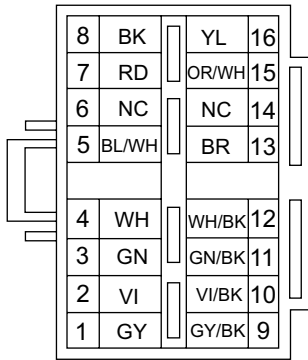

BK	Black	GN	Green
RD	Red	VI	Violet
BL	Blue	GY	Gray
WH	White	YL	Yellow
BR	Brown	OR	Orange

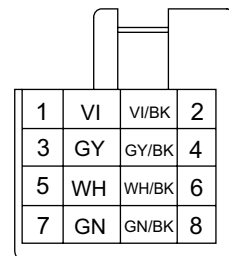
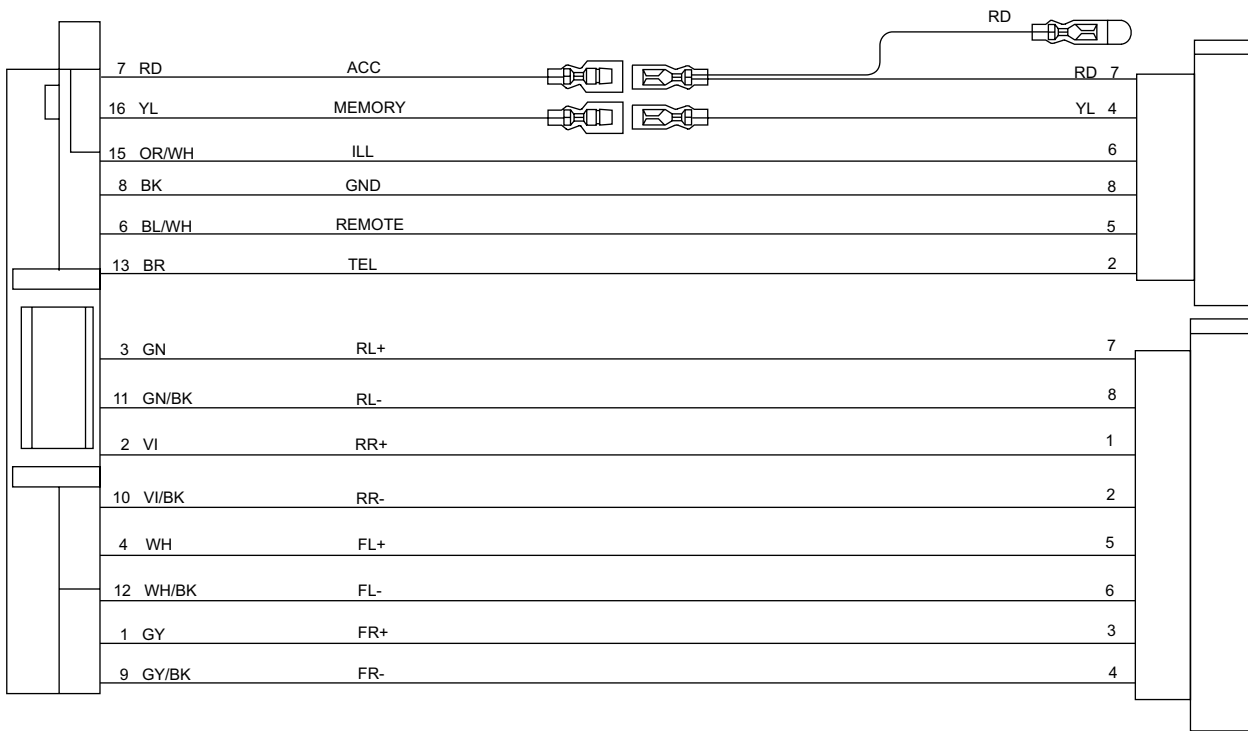
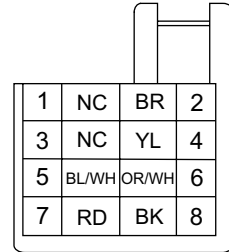

RR	Rear Right	ANT	Auto Antenna
FR	Front Right	ACC	ACC Line
FL	Front Left	TEL	Telephone Muting
RL	Rear Left	GND	Ground
REMOTE	Remote	MEMORY	Memory Backup Battery+
ILL	Illuminations Control		



JVC

Victor Company of Japan, Limited
AV & MULTIMEDIA COMPANY CAR ELECTRONICS CATEGORY 10-1,1chome,Ohwatari-machi,Maebashi-city,371-8543,Japan

(No.MA152)

JVC

SCHEMATIC DIAGRAMS

CD/SD RECEIVER

KD-LHX551, KD-LHX552 KD-LHX557

CD-ROM No.SML200503

KD-LHX551, KD-LHX552

Area suffix

E ----- Southern Europe
EX ----- Northern Europe
EY ----- Eastern Europe
EU ----- Turkey

KD-LHX557

Area suffix

EE ----- Russian Federation

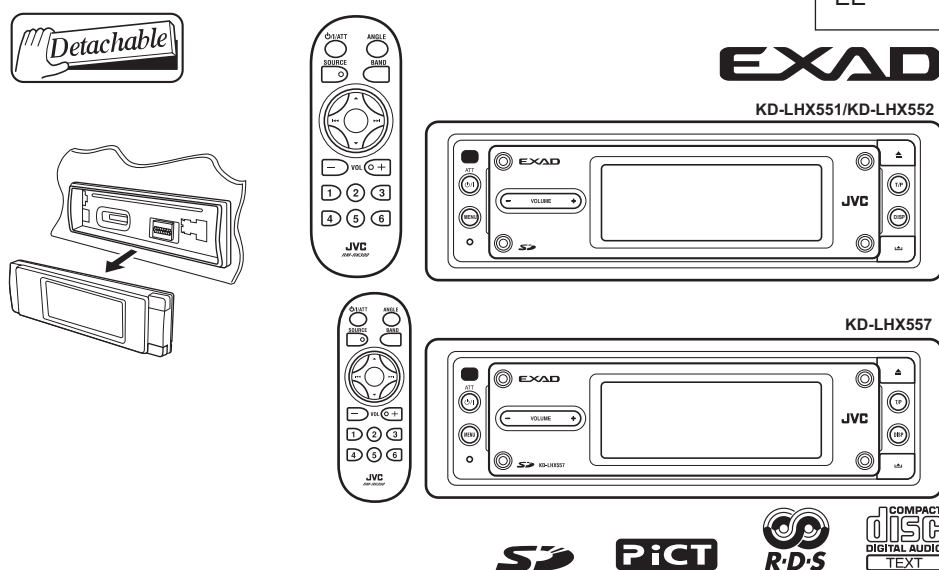

	KD-LHX551	KD-LHX552	KD-LHX557
Control Panel	SILVER	BLACK	BLACK

Contents

Block diagram	2-1
Standard schematic diagrams	2-2 to 10
Printed circuit boards	2-11 to 13

Safety precaution

 **CAUTION** Burrs formed during molding may be left over on some parts of the chassis. Therefore, pay attention to such burrs in the case of performing repair of this system.

 **CAUTION** Please use enough caution not to see the beam directly or touch it in case of an adjustment or operation check.

Block diagram

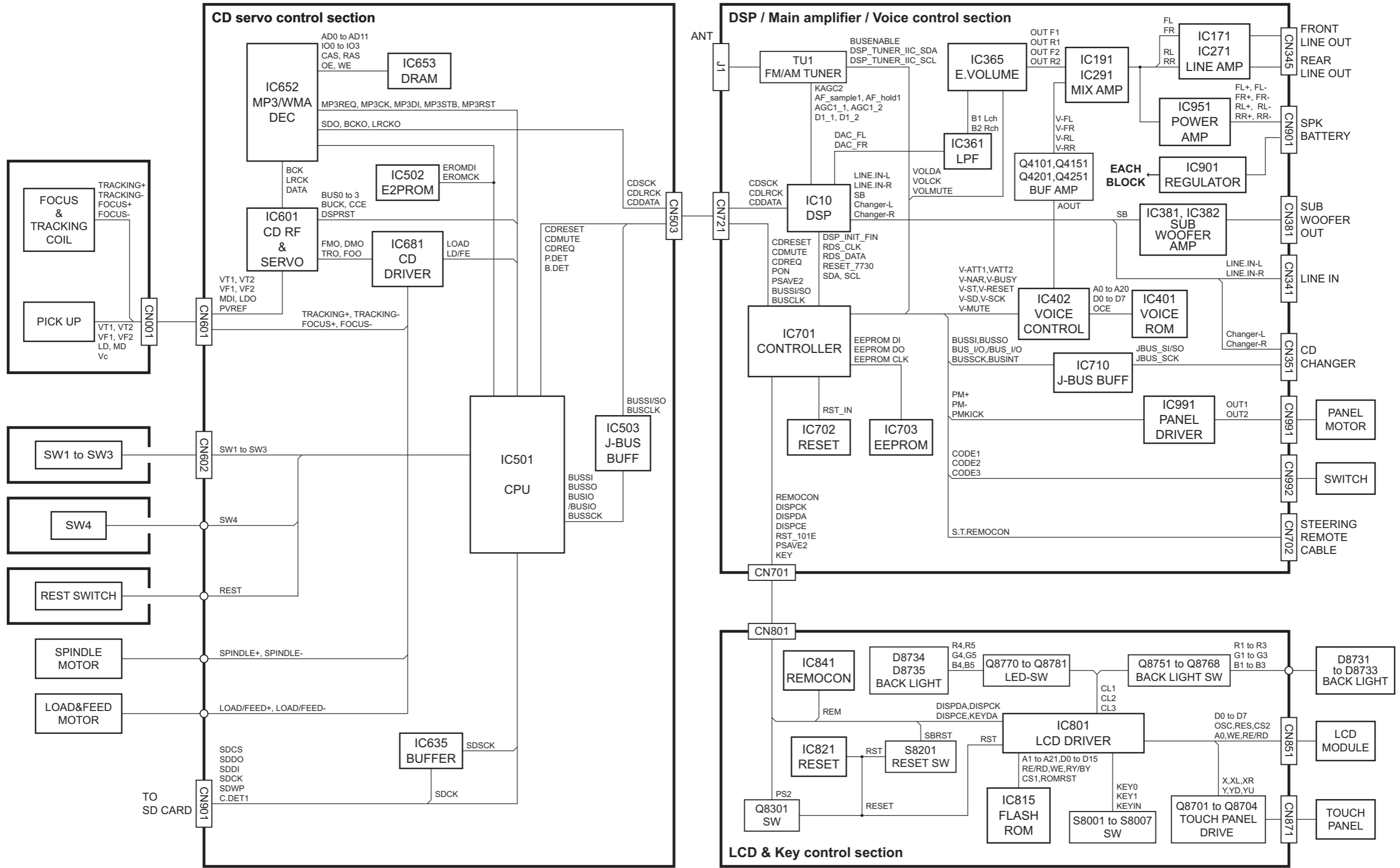

Standard schematic diagrams

■ DSP section (For KD-LHX551 & KD-LHX552)

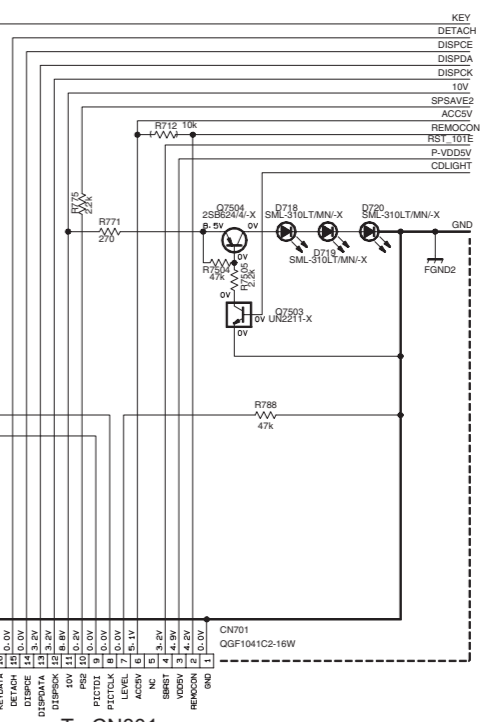
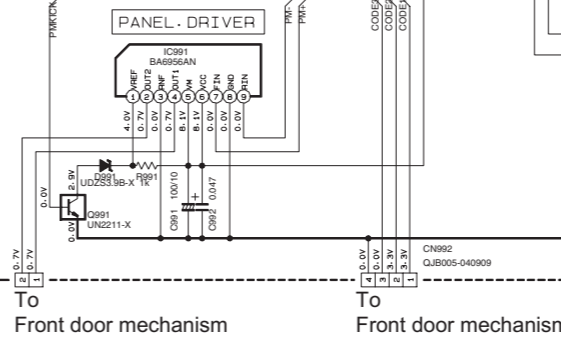
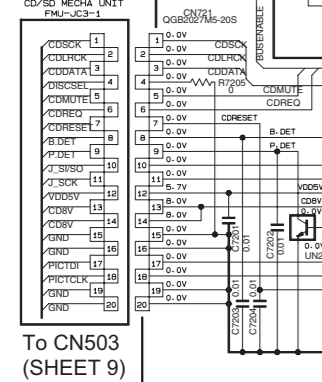
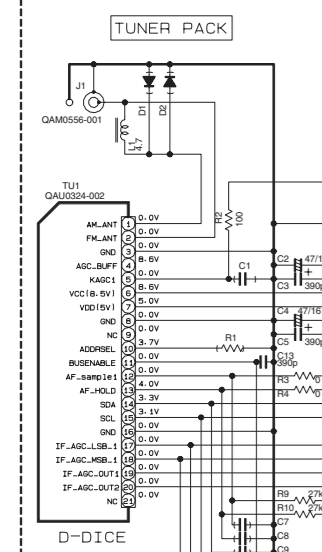
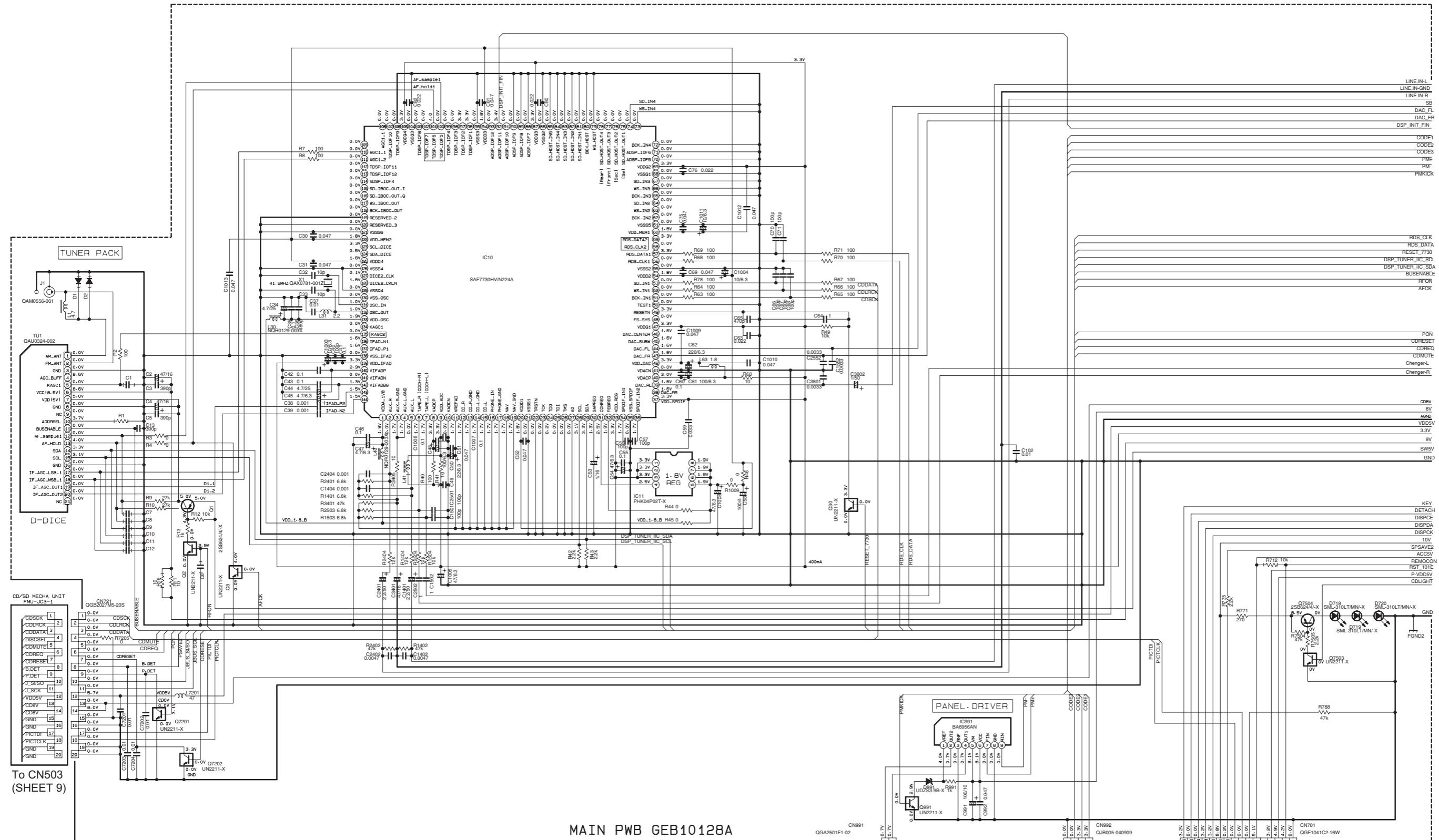

To CN503 (SHEET 9)

To Front door mechanism

To Front door mechanism

To CN801 (SHEET 4)

MAIN PWB GEB10128A

(SHEET 2)

■ Voice control section (For KD-LHX551 & KD-LHX552)

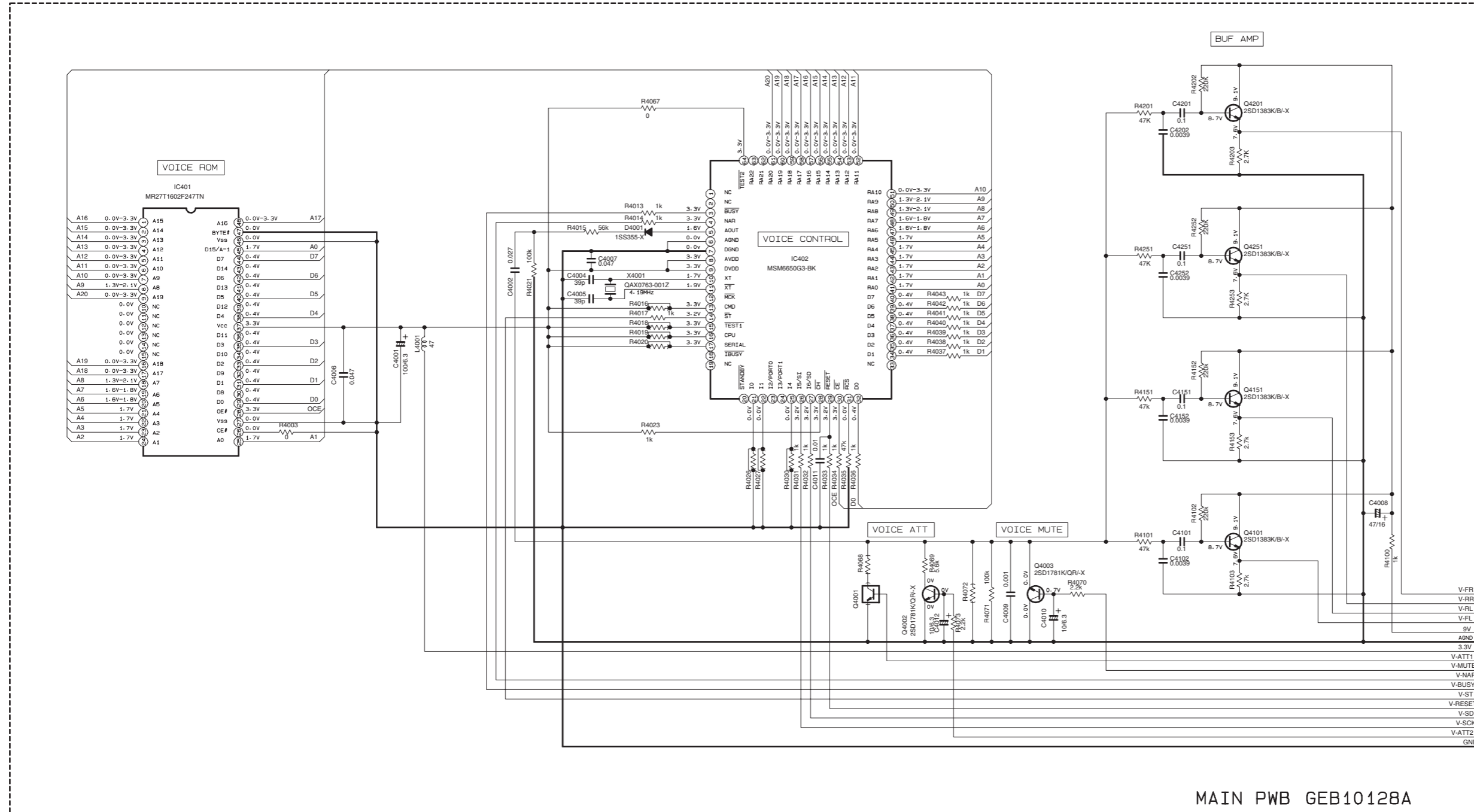

■ LCD & Key control section (For KD-LHX551 & KD-LHX552)

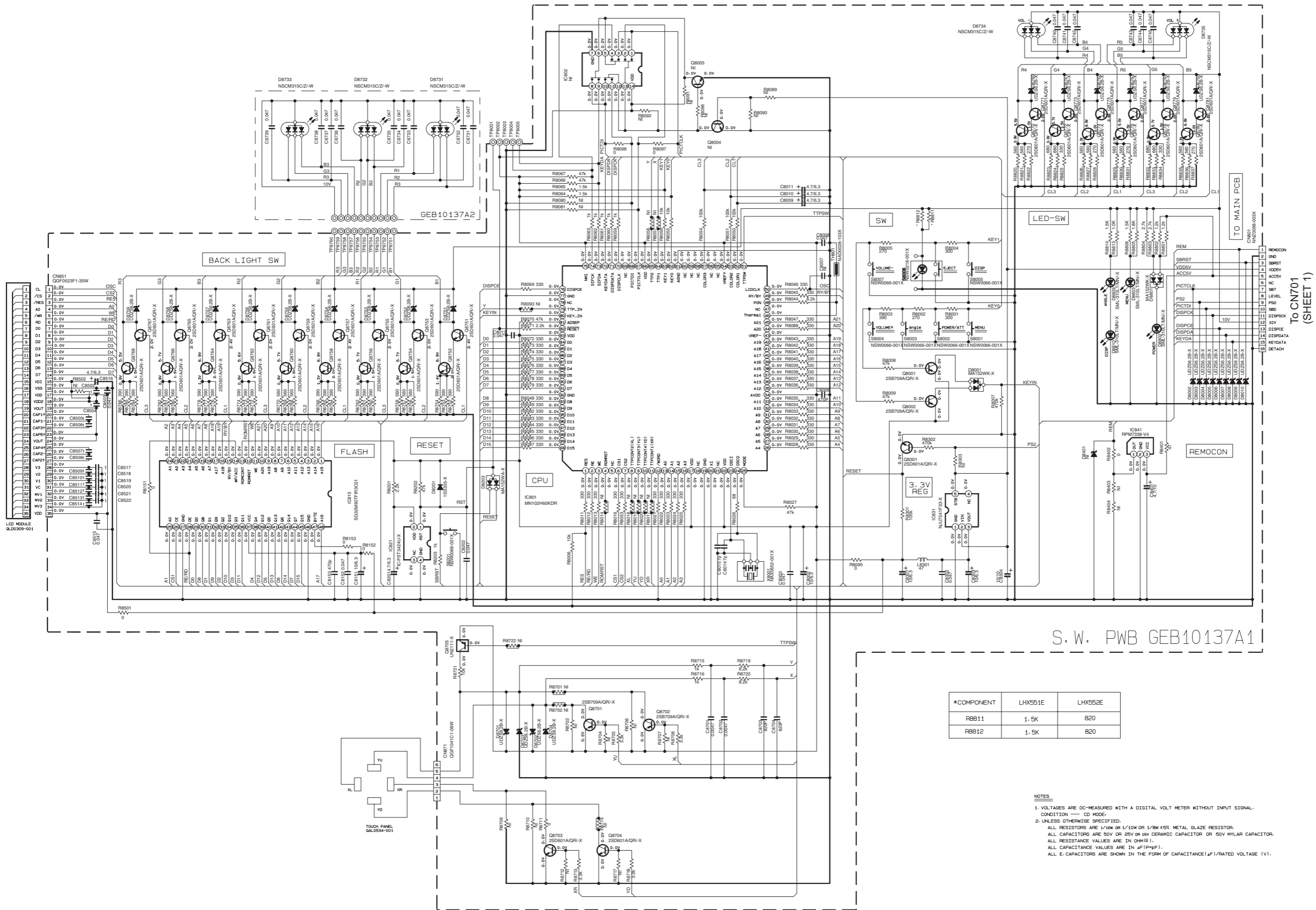

S.W. PWB GEB10137A1

*COMPONENT	LHX551E	LHX552E
R8811	1.5K	820
R8812	1.5K	820

- NOTES
1. VOLTAGES ARE DC-MEASURED WITH A DIGITAL VOLT METER WITHOUT INPUT SIGNAL. CONDITION — CD MODE.
 2. UNLESS OTHERWISE SPECIFIED. ALL RESISTORS ARE 1/16W OR 1/10W OR 1/8W ±5% METAL GLAZE RESISTOR. ALL CAPACITORS ARE 50V OR 25V OR 16V CERAMIC CAPACITOR OR 50V MYLAR CAPACITOR. ALL RESISTANCE VALUES ARE IN Ω(MΩ). ALL CAPACITANCE VALUES ARE IN μF(PμF). ALL E-CAPACITORS ARE SHOWN IN THE FORM OF CAPACITANCE(μF)/RATED VOLTAGE (V).

To CN701 (SHEET 1)

■ DSP section (For KD-LHX557)

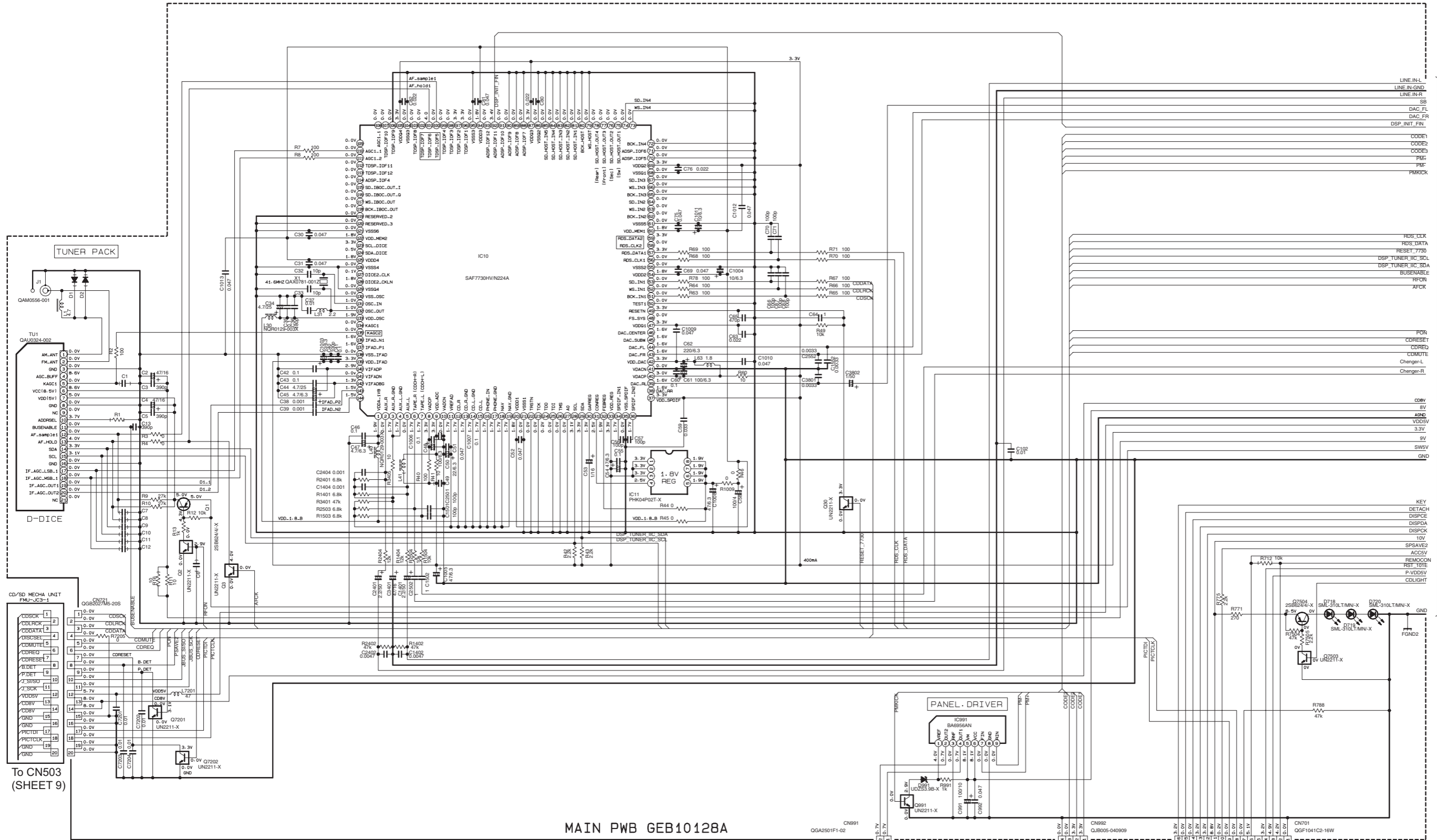

MAIN PWB GEB10128A

To CN503 (SHEET 9)

To Front door mechanism

To Front door mechanism

To CN801 (SHEET 8)

(SHEET 6)

■ Main amplifier section (For KD-LHX557)

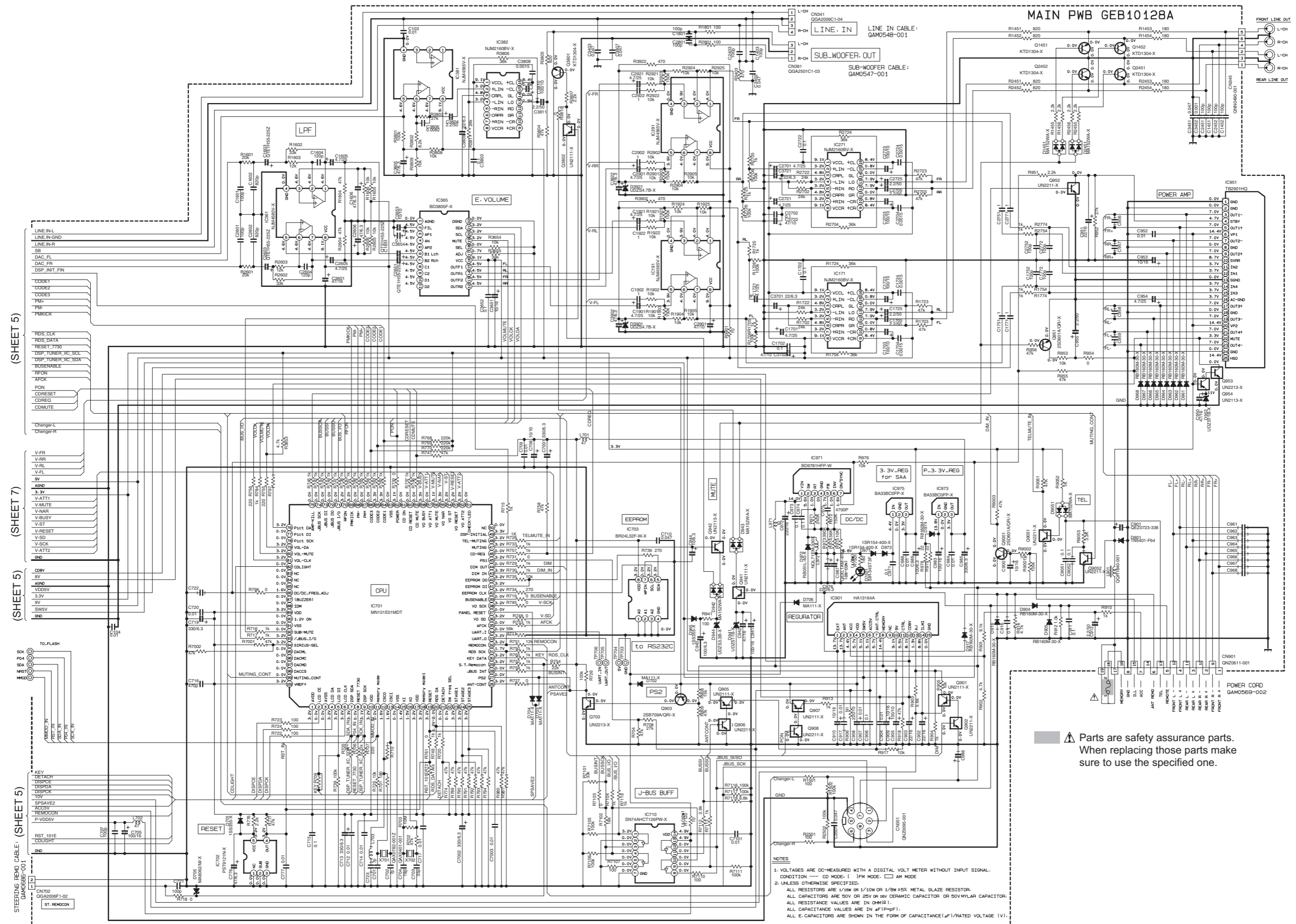

⚠ Parts are safety assurance parts. When replacing those parts make sure to use the specified one.

NOTES

- VOLTAGES ARE DC-MEASURED WITH A DIGITAL VOLT METER WITHOUT INPUT SIGNAL. CONDITION --- CD MODE, I IFM MODE, AM MODE
- UNLESS OTHERWISE SPECIFIED. ALL RESISTORS ARE 1/16W OR 1/10W OR 1/8W ±5% METAL GLAZE RESISTOR. ALL CAPACITORS ARE 50V OR 25V OR 16V CERAMIC CAPACITOR OR 50V/MLR CAPACITOR. ALL RESISTANCE VALUES ARE IN OHM(Ω). ALL CAPACITANCE VALUES ARE IN μF(μF). ALL E-CAPACITORS ARE SHOWN IN THE FORM OF CAPACITANCE (μF)/RATED VOLTAGE (V).

■ Voice control section (For KD-LHX557)

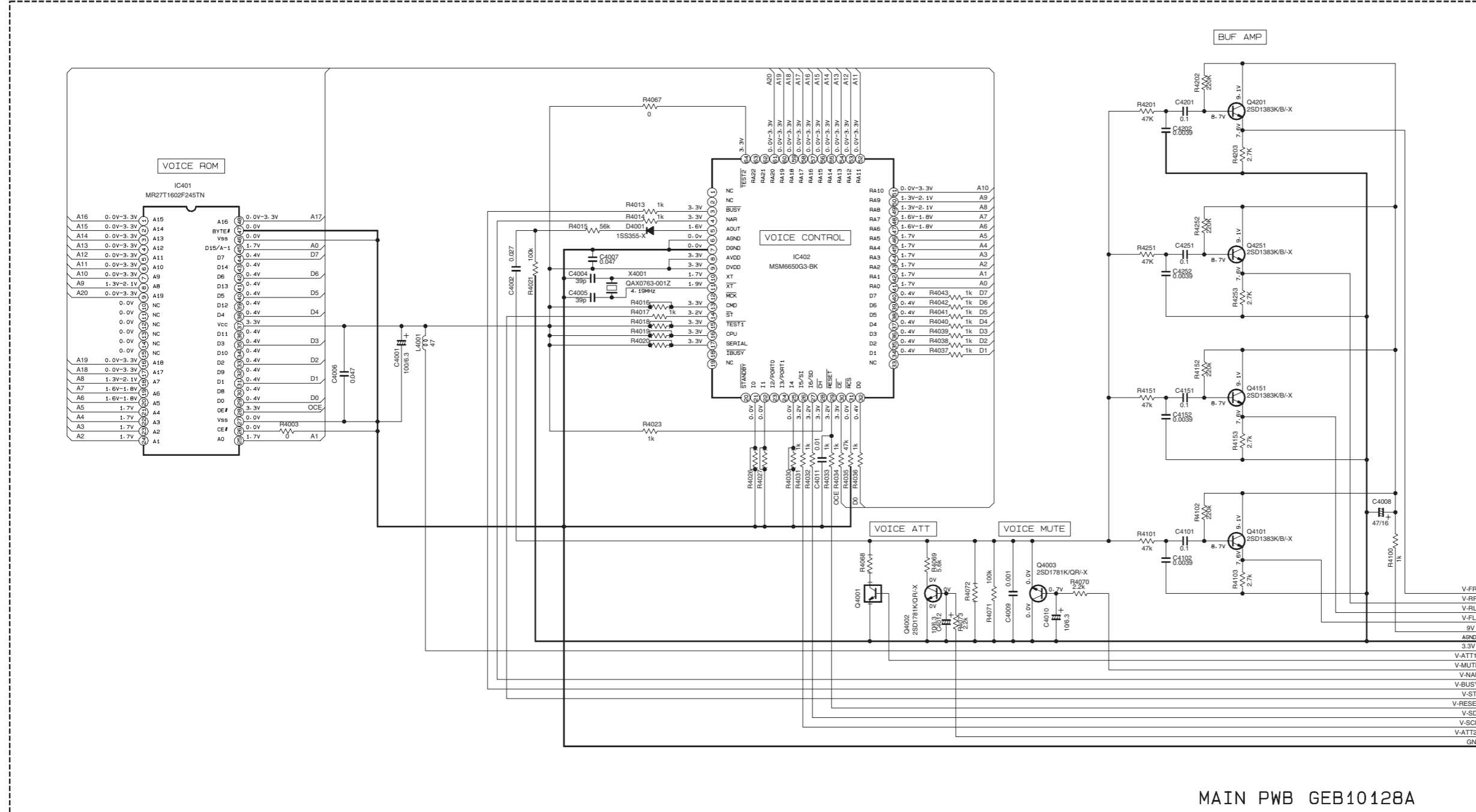

■ LCD & Key control section (For KD-LHX557)

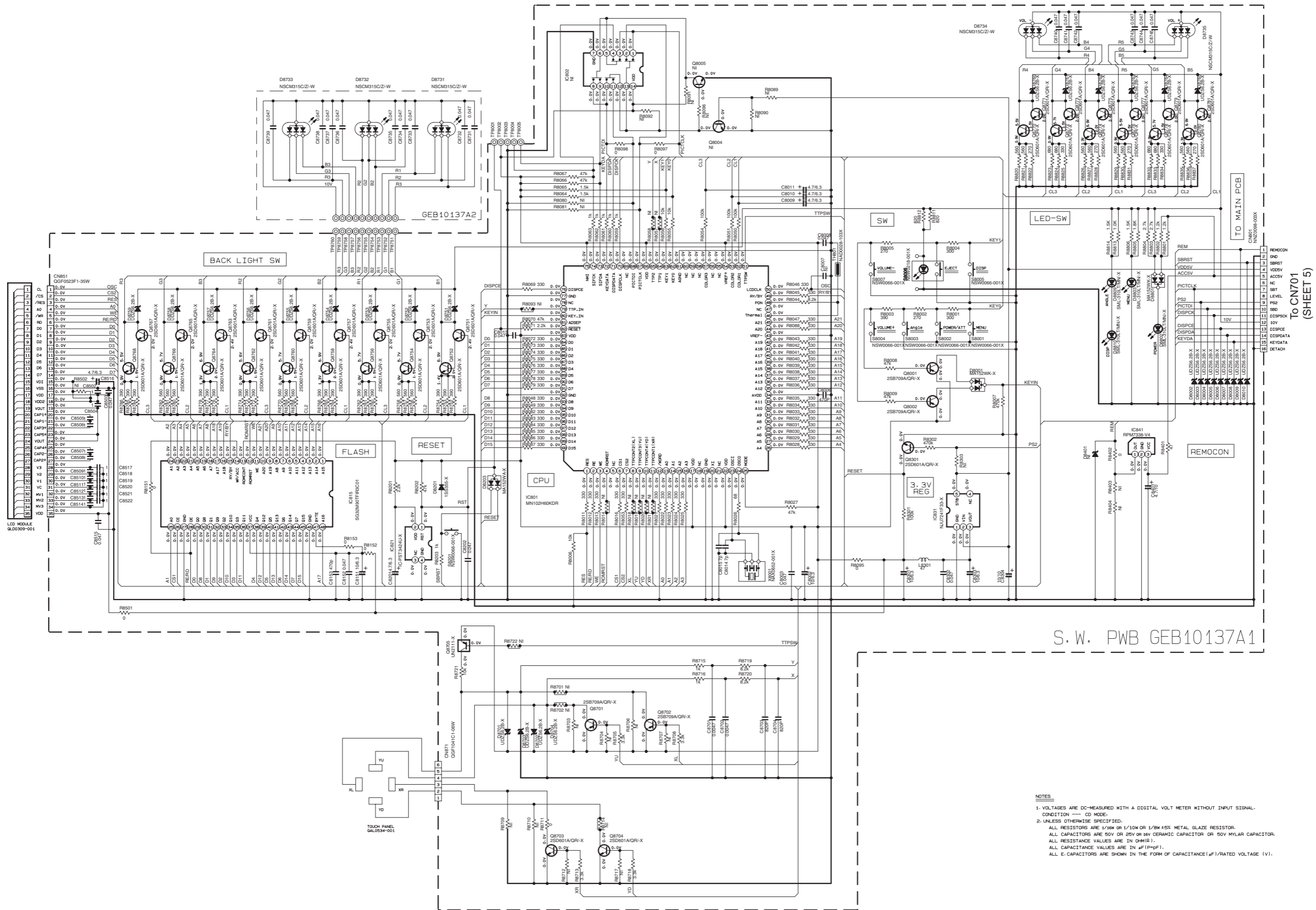

NOTES
1. VOLTAGES ARE DC-MEASURED WITH A DIGITAL VOLT METER WITHOUT INPUT SIGNAL.
CONDITION - CD MODE.
2. UNLESS OTHERWISE SPECIFIED,
ALL RESISTORS ARE 1/16W OR 1/10W OR 1/8W ±5% METAL GLAZE RESISTOR.
ALL CAPACITORS ARE 50V OR 25V OR 16V CERAMIC CAPACITOR OR 50V MYLAR CAPACITOR.
ALL RESISTANCE VALUES ARE IN Ω(MΩ).
ALL CAPACITANCE VALUES ARE IN pF(PpF).
ALL E-CAPACITORS ARE SHOWN IN THE FORM OF CAPACITANCE(μF)/RATED VOLTAGE (V).

CD servo control section (Common)

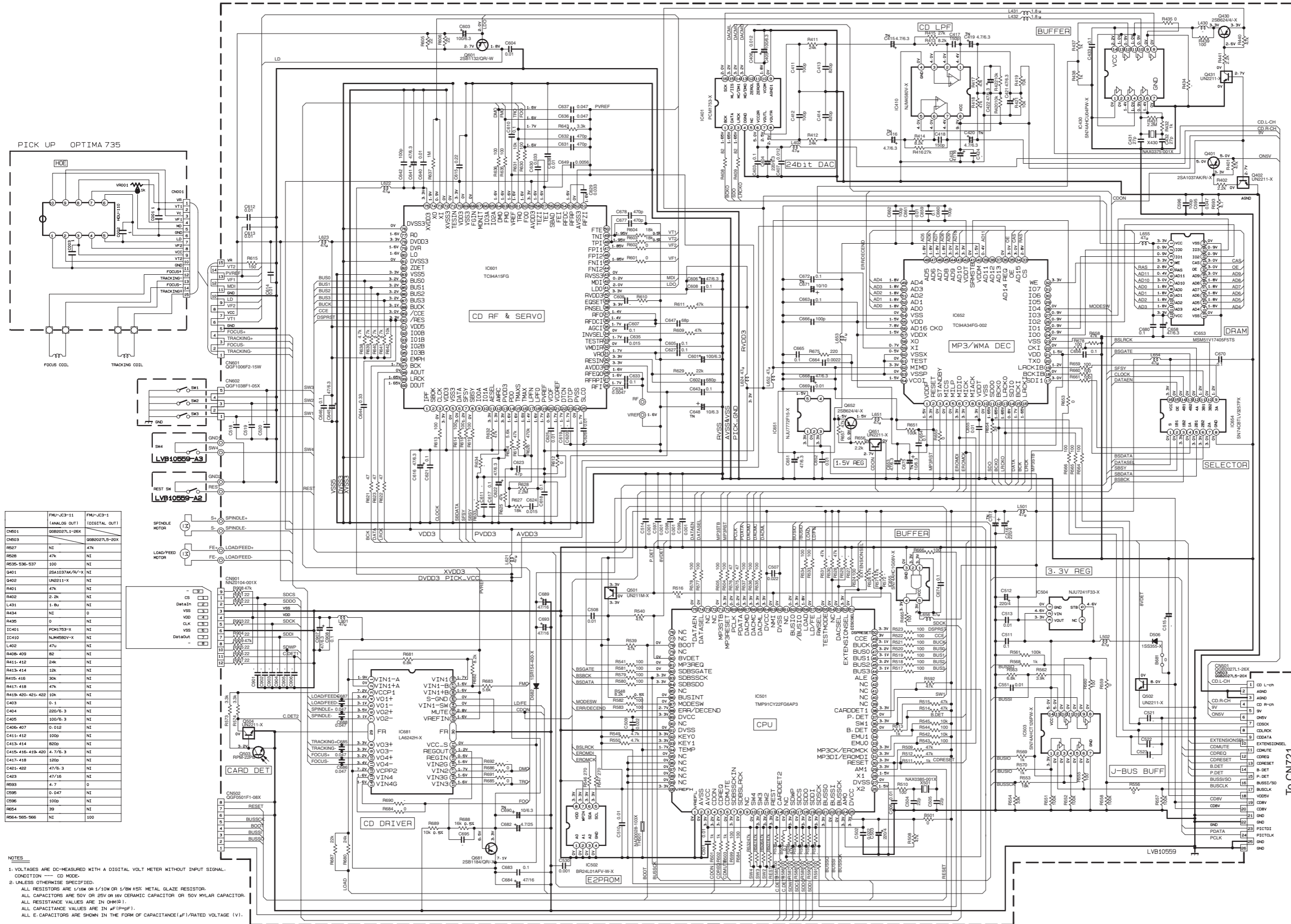

	FMU-JC3-11 (ANALOG OUT)	FMU-JC3-1 (DIGITAL OUT)
CN501	06B0207L1-26X	
CN503	06B0207L5-20X	
R627	NI	47k
R628	NI	47k
R635-636-637	100	NI
Q401	2SA1037AK/R-X	NI
Q402	UN2211-X	NI
R401	47k	NI
R402	2.2k	NI
L431	1.8u	NI
R434	NI	0
R435	0	NI
IC401	PCM1753-X	NI
IC410	NJM4580V-X	NI
L402	47u	NI
R406-409	82	NI
R411-412	24k	NI
R413-414	12k	NI
R415-416	30k	NI
R417-418	47k	NI
R419-420-421-422	10k	NI
C403	0.1	NI
C404	220/6.3	NI
C405	100/6.3	NI
C406-407	0.012	NI
C411-412	100p	NI
C413-414	820p	NI
C415-416-419-420	4.7/6.3	NI
C417-418	120p	NI
C421-422	47/6.3	NI
C423	47/16	NI
R693	4.7	0
C595	0.047	NI
C596	100p	NI
R654	39	NI
R654-565-566	100	NI

NOTES
 1. VOLTAGES ARE DC-MEASURED WITH A DIGITAL VOLT METER WITHOUT INPUT SIGNAL. CONDITION — CD MODE.
 2. UNLESS OTHERWISE SPECIFIED:
 ALL RESISTORS ARE 1/16W OR 1/10W OR 1/8W 5% METAL GLAZE RESISTOR.
 ALL CAPACITORS ARE 50V OR 25V OR 16V CERAMIC CAPACITOR OR 50V MYLAR CAPACITOR.
 ALL RESISTANCE VALUES ARE IN OHM(Ω).
 ALL CAPACITANCE VALUES ARE IN pF(pF).
 ALL E-CAPACITORS ARE SHOWN IN THE FORM OF CAPACITANCE(μF)/RATED VOLTAGE (V).

To CN721
(SHEET 1 OF SHEET 5)

Printed circuit boards

■ Main board

Forward side

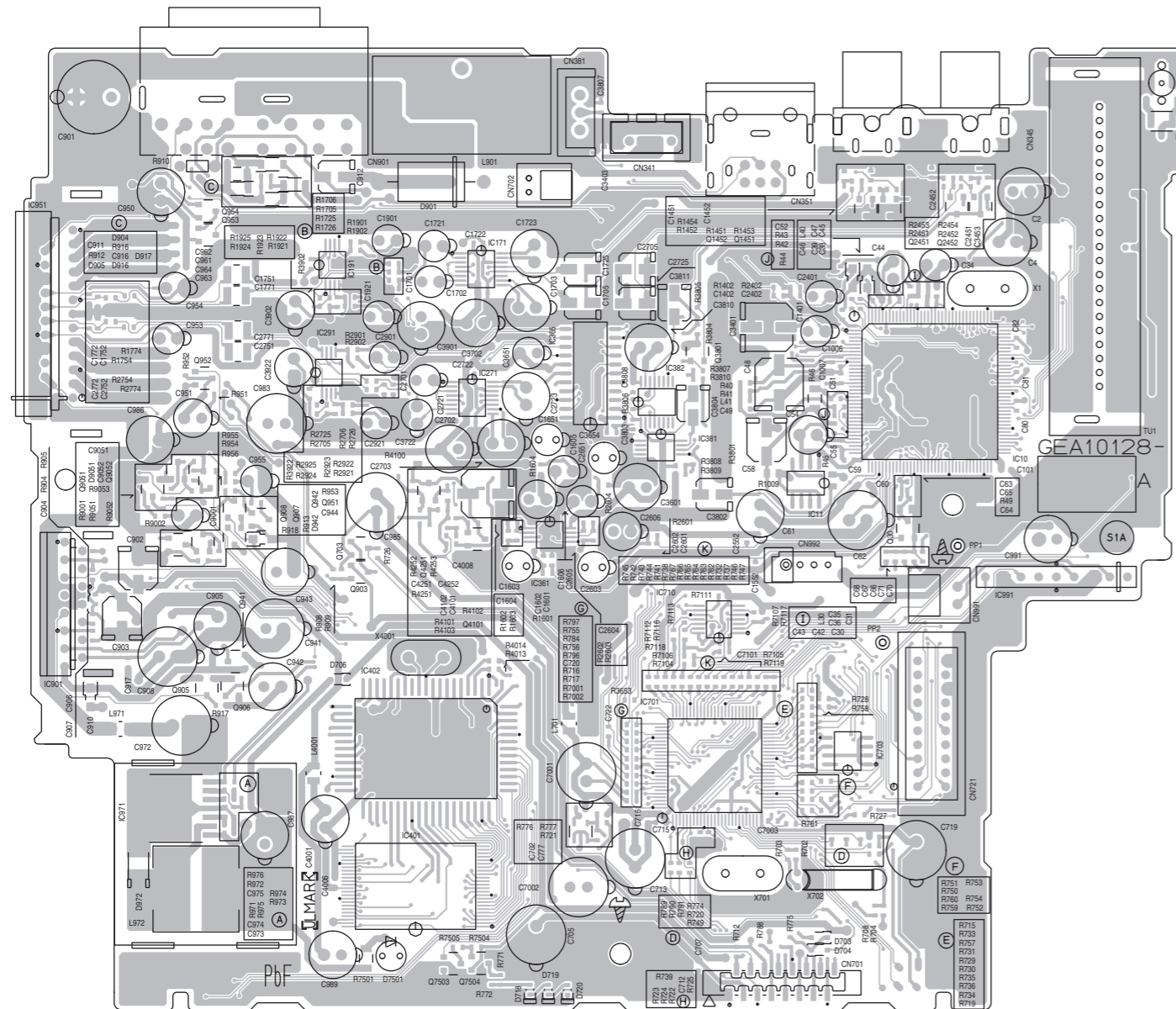

Reverse side

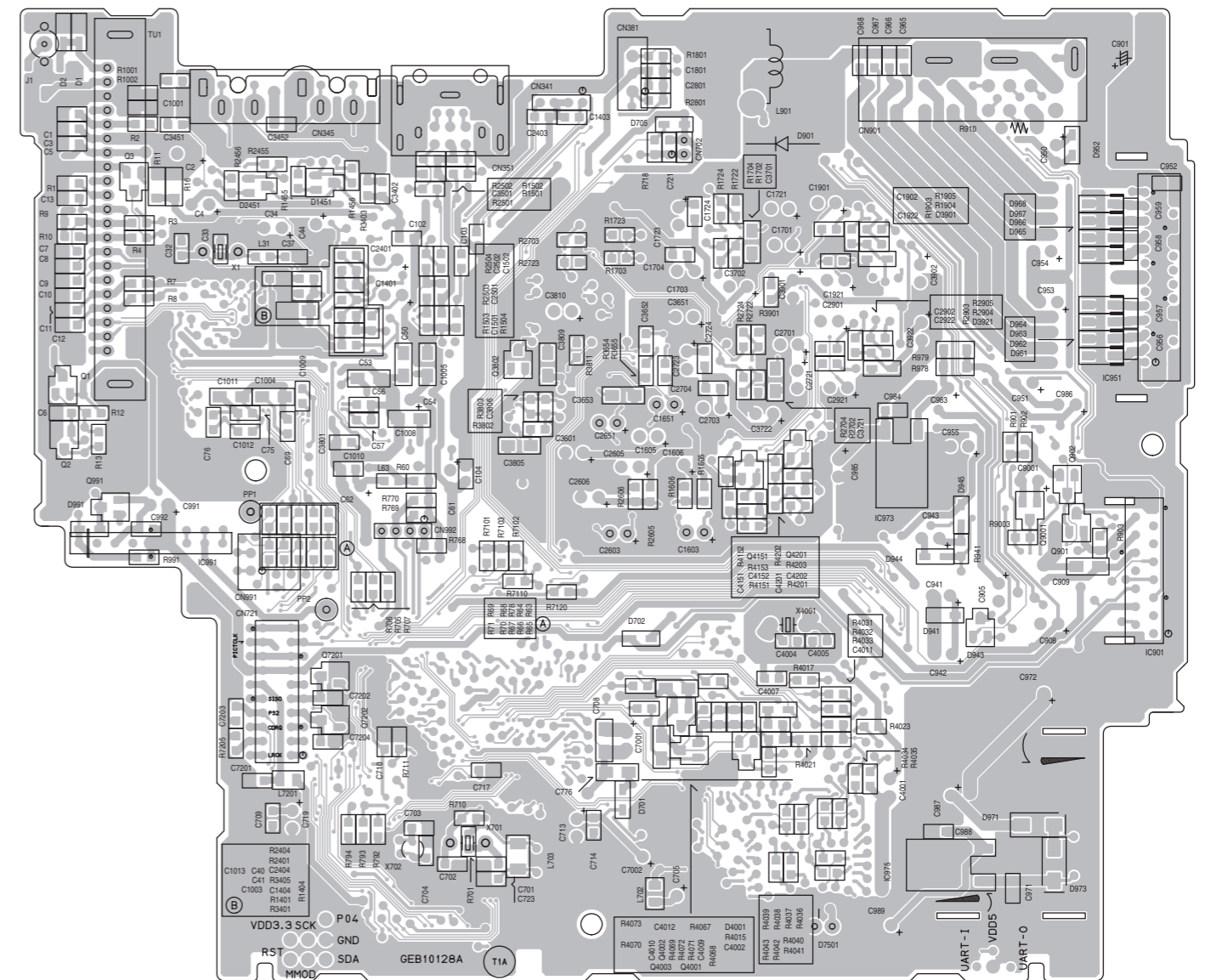

■ Mecha control board

Forward side

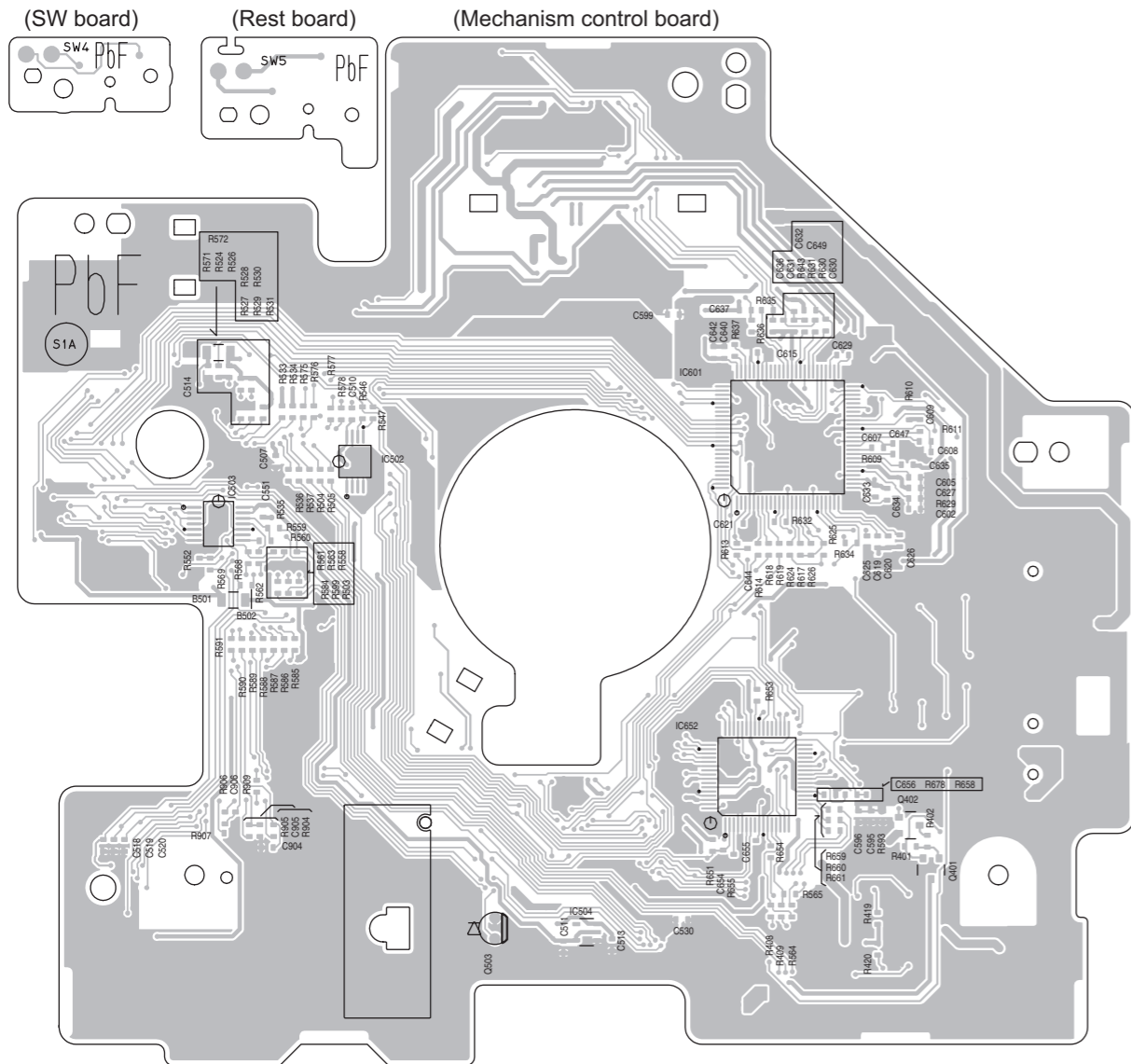

Reverse side

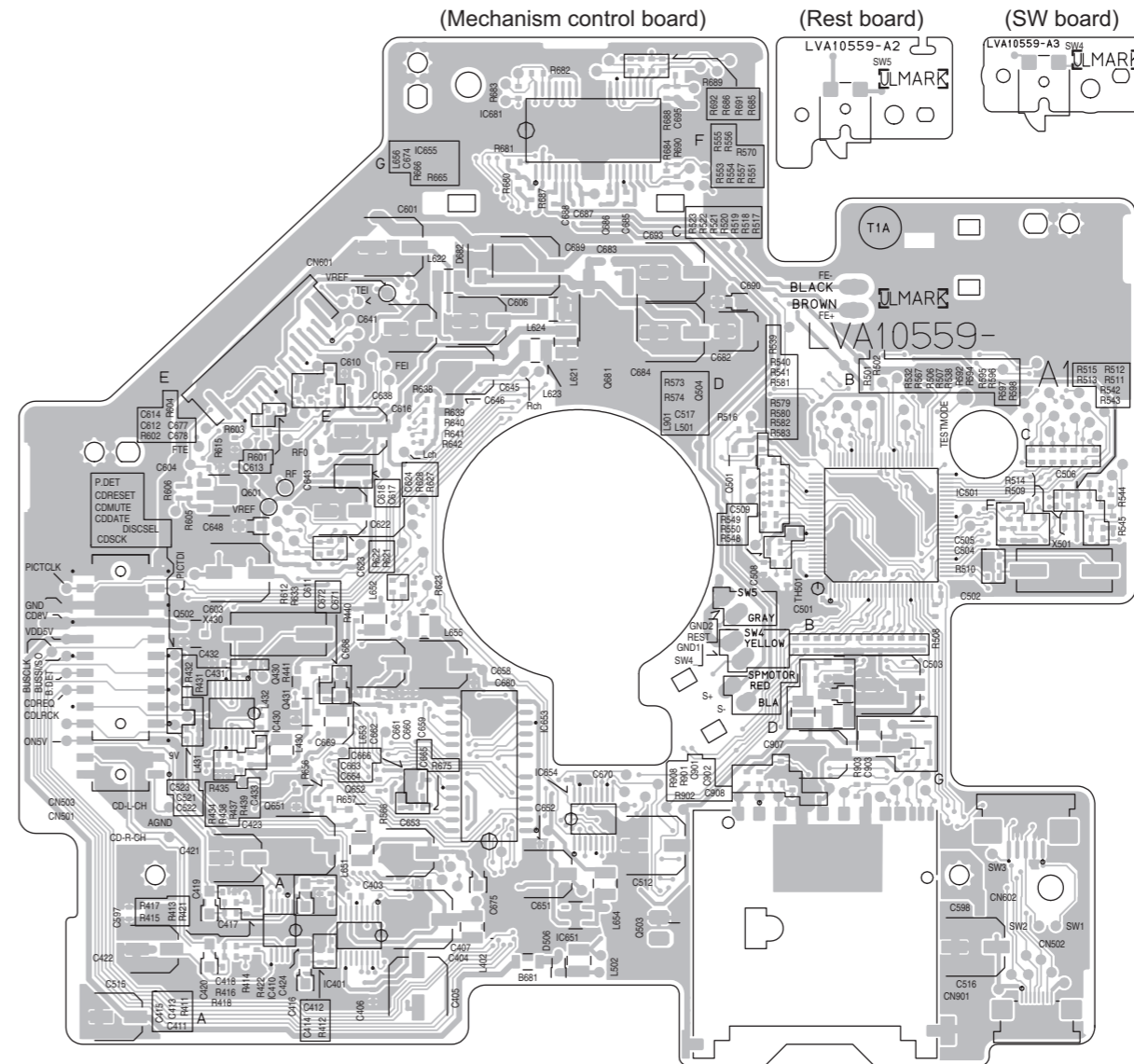

Switch board

Forward side

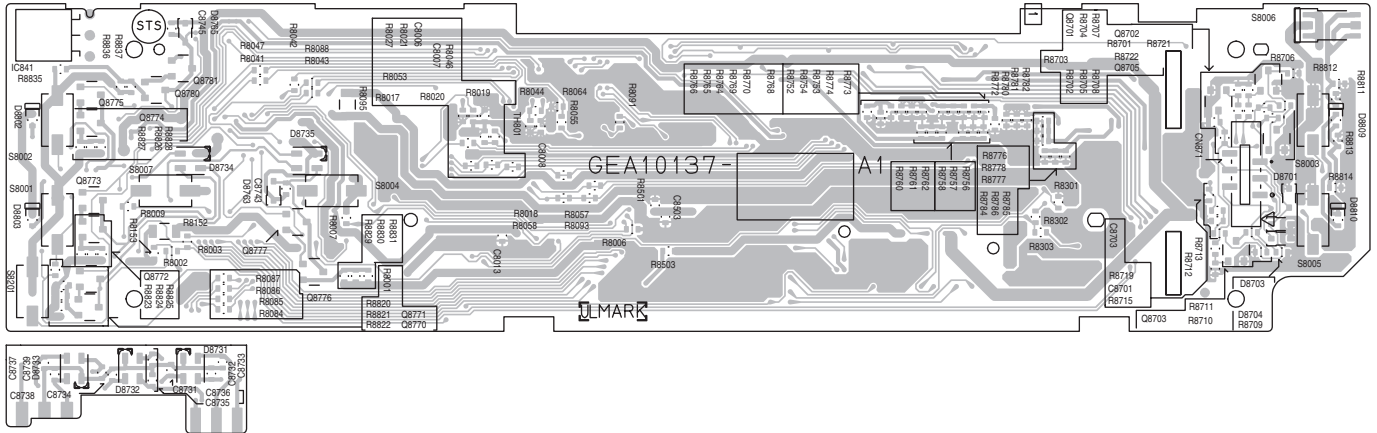

Reverse side

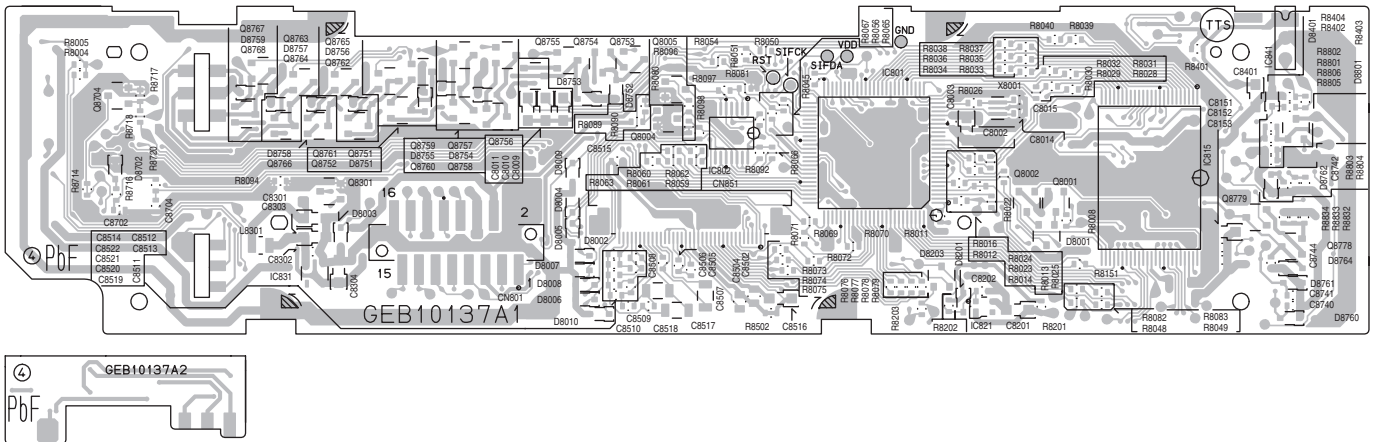

PARTS LIST

[KD-LHX551] [KD-LHX552]
[KD-LHX557]

* All printed circuit boards and its assemblies are not available as service parts.

KD-LHX551, KD-LHX552

Area suffix

E ----- Southern Europe
EX ----- Northern Europe
EY ----- Eastern Europe
EU ----- Turkey

KD-LHX557

Area suffix

EE ----- Russian Federation

- Contents -

Exploded view of general assembly and parts list (Block No.M1)	3- 2
CD mechanism assembly and parts list (Block No.MB)	3- 6
Electrical parts list (Block No.01~03)(KD-LHX551/552)	3- 9
Electrical parts list (Block No.04~06)(KD-LHX557)	3-18
Packing materials and accessories parts list (Block No.M3)	3-28

Exploded view of general assembly and parts list

Block No. **M 1 M M**

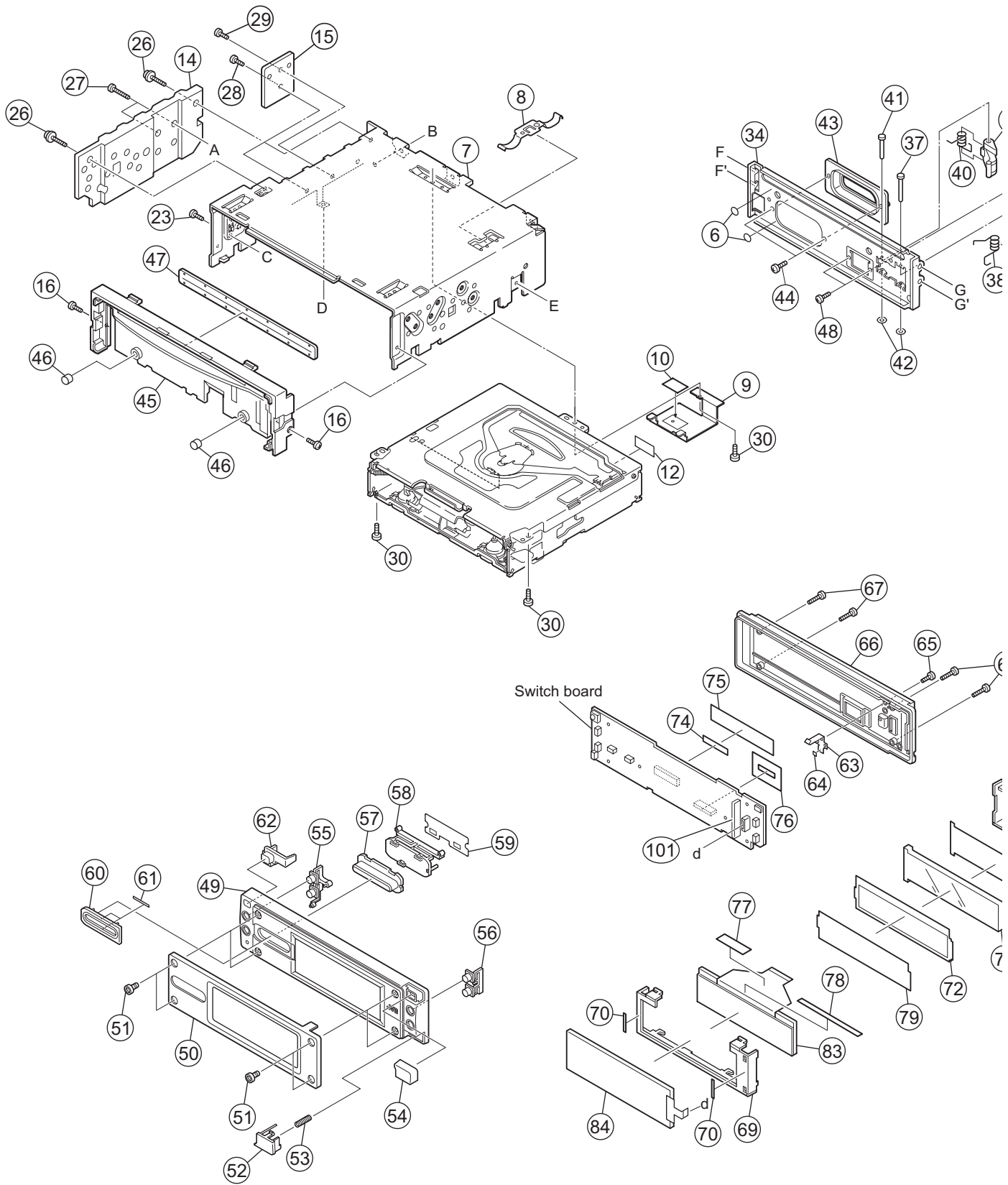

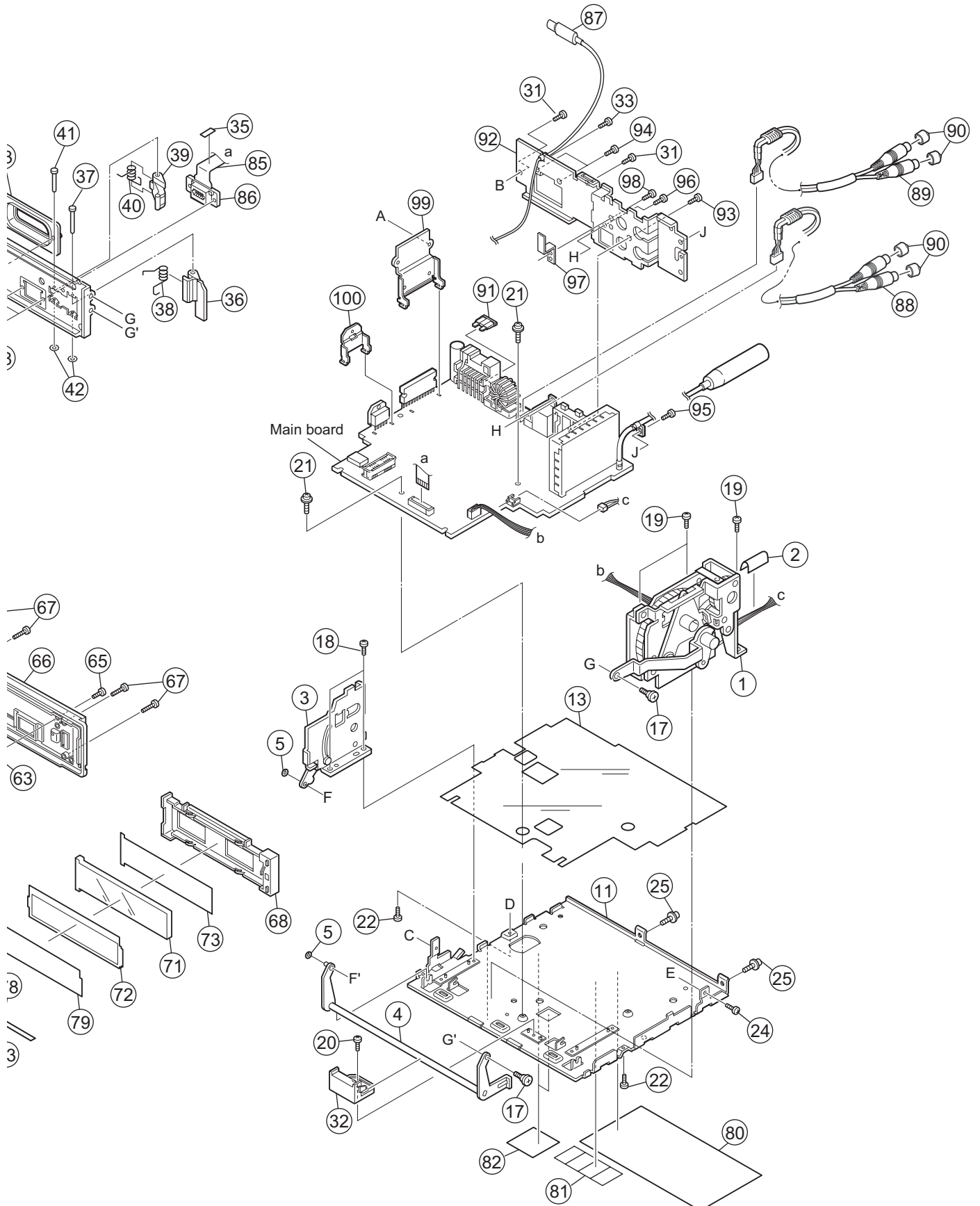

General Assembly

Block No. [M][1][M][M]

Symbol No.	Part No.	Part Name	Description	Local
1	GE20156-001A	GEAR BKT UNIT		
2	FSYH4036-100	SHEET		
3	GE30968-002A	LEVER BKT UNIT		
4	GE30964-003A	LOWER LEVER ASS		
5	WDL215025	WASHER	(x2)	
6	GE40218-017A	SHEET	(x2)	
7	GE10111-001A	TOP CHASSIS		
8	GE40135-001A	EARTH PLATE		
9	GE40259-001A	MECHA HEAT SINK		
10	LV43854-003A	COOLING RUBBER		
11	GE10074-001A	BOTTOM CHASSIS		
12	FSYH4036-100	SHEET		
13	GE31204-003A	INSULATOR		
14	GE31627-001A	HEAT SINK		
15	GE40260-001A	IC HEAT SINK		
16	QYSPSP2003ZA	SCREW	M2 x 3mm(x2)	
17	LV42181-002A	SPECIAL SCREW	(x2)	
18	LV40865-002A	SCREW	(x2)	
19	LV40865-002A	SCREW	(x3)	
20	LV40865-002A	SCREW		
21	LV41200-004A	SPECIAL SCREW	(x2)	
22	QYSDST2606ZA	TAP SCREW	M2.6 x 6mm(x2)	
23	QYSDST2604ZA	TAP SCREW	M2.6 x 4mm	
24	QYSDST2604ZA	TAP SCREW	M2.6 x 4mm	
25	LV41200-004A	SPECIAL SCREW	(x2)	
26	GE40235-001A	SCREW	(x2)	
27	QYSDST2610ZA	TAP SCREW	M2.6 x 10mm(x2)	
28	QYSDST2606ZA	TAP SCREW	M2.6 x 6mm	
29	QYSDST2606ZA	TAP SCREW	M2.6 x 6mm	
30	QYSDST2605ZA	TAP SCREW	M2.6 x 5mm(x3)	
31	QYSDST2604ZA	TAP SCREW	M2.6 x 4mm(x2)	
32	GE30974-001A	FPC GUIDE		
33	QYSDST2604ZA	TAP SCREW	M2.6 x 4mm	
34	LV35330-003A	FRONT BKT ASSY		
35	FSYH4036-100	SHEET		
36	GE30972-001A	DETACH LEVER		
37	GE40192-002A	SHAFT		
38	GE40195-002A	T SPRING		
39	GE30973-001A	KICK LEVER		
40	GE40194-001A	T SPRING		
41	GE40193-002A	SHAFT		
42	WDL123525	SLIT WASHER	(x2)	
43	LV35381-001A	SD GUIDE		
44	VKZ4777-009	MINI SCREW	(x2)	
45	GE31642-001A	F. CHASSIS ASSY		
46	GE40196-002A	ABSORBER	(x2)	
47	GE40156-001A	BLIND		
48	QYSPSGU2040MA	TAP SCREW	M2 x 4mm(x2)	
49	LV35128-005A	F PANEL ASSY		LHX551E,LHX551EU,LHX551EX,LHX551EY
49	LV35128-006A	F.PANEL ASSY		LHX552E,LHX552EU,LHX552EX,LHX552EY, LHX557EE
50	GE20177-007A	AL PLATE		LHX551E,LHX551EU,LHX551EX,LHX551EY
50	GE20177-008A	AL PLATE		LHX552E,LHX552EU,LHX552EX,LHX552EY
50	GE20177-009A	AL PLATE		LHX557EE
51	LV43699-001A	SPECIAL SCREW	(x4)	
52	LV34690-001A	DETACH BUTTON		LHX551E,LHX551EU,LHX551EX,LHX551EY
52	LV34690-002A	DETACH BUTTON		LHX552E,LHX552EU,LHX552EX,LHX552EY, LHX557EE
53	LV43703-001A	COMPRESSION SPRING		
54	LV34752-001A	BUTTON ASSY		LHX551E,LHX551EU,LHX551EX,LHX551EY
54	LV34752-003A	BUTTON ASSY		LHX552E,LHX552EU,LHX552EX,LHX552EY, LHX557EE
55	LV34692-007A	POWER BUTTON		LHX551E,LHX551EU,LHX551EX,LHX551EY
55	LV34692-008A	POWER BUTTON		LHX552E,LHX552EU,LHX552EX,LHX552EY, LHX557EE
56	LV34693-017A	PUSH BUTTON		LHX551E,LHX551EU,LHX551EX,LHX551EY
56	LV34693-019A	PUSH BUTTON		LHX552E,LHX552EU,LHX552EX,LHX552EY, LHX557EE
57	LV34695-001A	VOL BUTTON		
58	LV34696-002A	BUTTON BASE(V)		
59	GE40277-001A	LIGHTING SHEET		
60	LV34702-001A	VOLUME FITTING		
61	LV43906-001A	DOUBLE FACE	(x2)	
62	LV34697-001A	REMOTE LENS		
63	LV34701-002A	LEAF SPRING		

△	Symbol No.	Part No.	Part Name	Description	Local
	64	LV40848-046A	SPACER(P)		
	65	QYSPSPU1730ZA	SCREW	M1.7 x 3mm	
	66	LV10871-006A	REAR COVER		
	67	VKZ4777-010	MINI SCREW	(x4)	
	68	LV34699-003A	LCD HOLDER		
	69	LV34698-003A	LCD CASE		
	70	LV43906-001A	DOUBLE FACE	(x2)	
	71	LV34700-001A	LCD LENS		
	72	LV43710-001A	LCD FILTER		
	73	LV43712-002A	LENS SHEET		
	74	LV43084-001A	DOUBLE FACE		
	75	LV40848-034A	SPACER(P)		
	76	LV43889-001A	SW PWB SHEET		
	77	LV40846-036A	SPACER(F)		
	78	LV43912-001A	SHEET		
	79	LV43713-002A	BRIGHT SHEET		
	80	GE31548-001A	NAME PLATE		LHX551E,LHX551EU,LHX551EX,LHX551EY
	80	GE31551-001A	NAME PLATE		LHX552E,LHX552EU,LHX552EX,LHX552EY
	80	GE31621-001A	NAME PLATE		LHX557EE
	81	LV41843-002A	LASER CAUTION		
	82	GE40218-011A	SHEET		
	83	QLD0309-001	LCD MODULE		
	84	QAL0534-001	TOUCH PANEL		
	85	QAL0587-001	FPC CABLE		
	86	QNZ0664-003	FRONT CONNECTOR		
	87	QAM0686-001	STEERING REMOTE		
	88	QAM0548-001	L-IN CABLE		
	89	QAM0547-001	SUBWOOFER CABEL		
	90	VYTA500-001	PIN CAP	(x4)	
△	91	QMFZ047-150-T	FUSE	15A	
	92	GE31205-013A	REAR BRACKET		
	93	QYSDSF2606ZA	TAP SCREW	M2.6 x 6mm	
	94	QYSDSF2606ZA	TAP SCREW	M2.6 x 6mm(x2)	
	95	LV41200-004A	SPECIAL SCREW		
	96	QYSDST2606ZA	TAP SCREW	M2.6 x 6mm	
	97	GE40214-001A	WIRE HOLDER		
	98	QYSDST2604ZA	TAP SCREW	M2.6 x 4mm	
	99	GE40207-001A	POWER IC BKT		
	100	GE40124-002A	REG BRACKET		
	101	GE40258-001A	SHIELD COVER		

CD mechanism assembly and parts list

FMU-JC3-1D

Block No. M B M M

Grease

- ★ = JVS-1003
- = MOBIL-1
- ▲ = JVG-31N
- = JC-803B

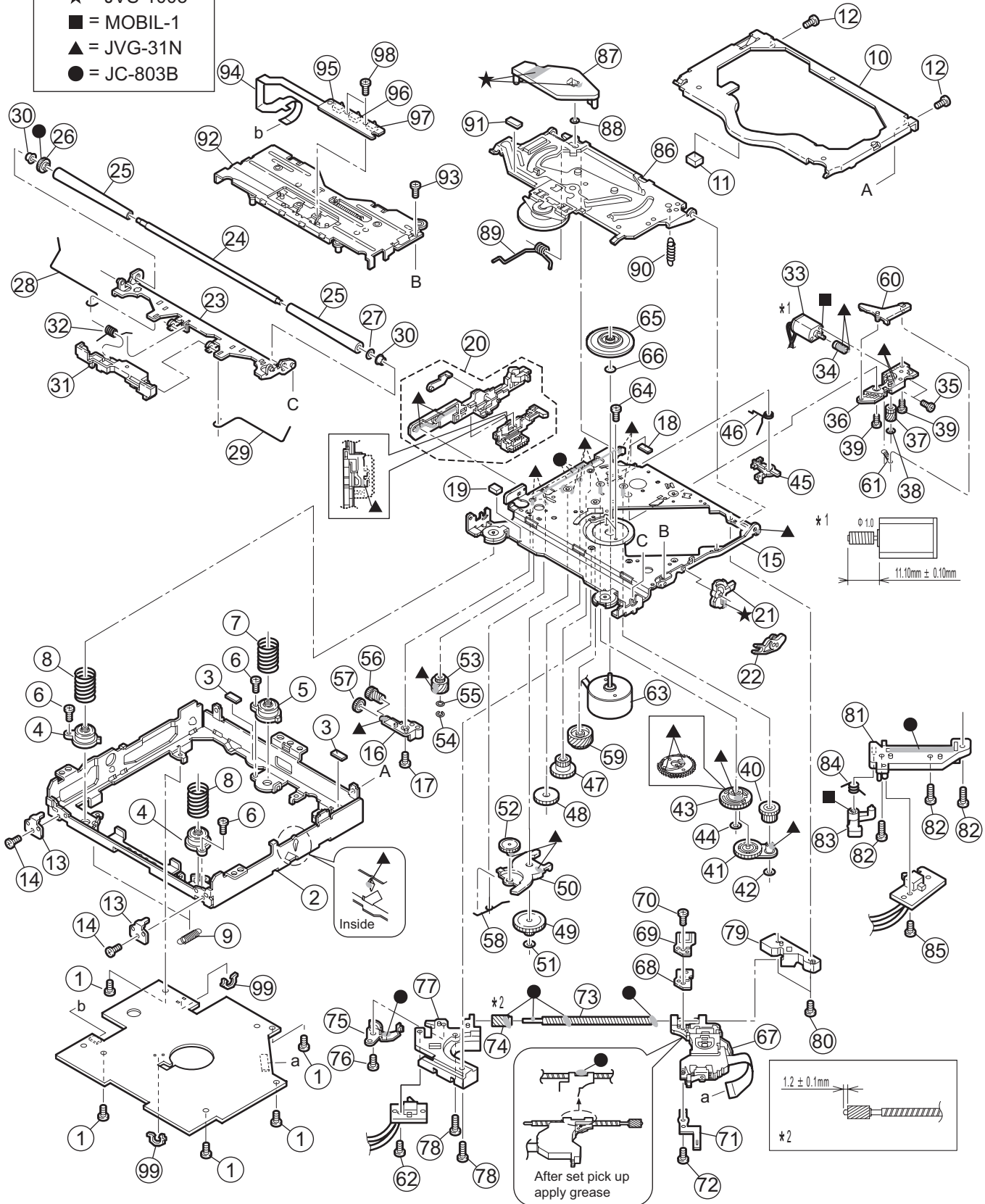

The parts without symbol number are not service.

CD mechanism

Block No. [M][B][M][M]

△	Symbol No.	Part No.	Part Name	Description	Local
	1	VKZ4539-056	MINI SCREW	(x5)	
	2	LV10857-002A	CHASSIS FRAME 2		
	3	LV30225-0J6A	SPACER	(x2)	
	4	LV35272-001A	DAMPER(F)	(x2)	
	5	LV35273-001A	DAMPER(R)		
	6	QYSPSTU2045MA	TAP SCREW	M2 x 4.5mm(x3)	
	7	LV43039-001A	DAMPER SP.(R)		
	8	LV43849-001A	DAMPER SP.(F2)	(x2)	
	9	LV43041-001A	FLOATING SPRING	(x2)	
	10	LV10675-001A	TOP COVER		
	11	LV30225-0J5A	SPACER		
	12	VKZ4539-056	MINI SCREW	(x2)	
	13	LV33669-001A	STOPPER	(x2)	
	14	VKZ4539-056	MINI SCREW	(x2)	
	15	LV21615-001A	CD CHASSIS ASSY		
	16	LV33608-001A	GEAR HOLDER		
	17	VKZ4539-056	MINI SCREW		
	18	LV43561-002A	ABSORBER		
	19	LV30225-0J5A	SPACER		
	20	LV33683-003A	SLIDE CAM ASSY		
	21	LV33610-001A	FLOATING ARM		
	22	LV33611-001A	CONNECT ARM		
	23	LV33678-003A	LOADING A. ASSY		
	24	LV43049-001A	LOADING SHAFT		
	25	LV43052-003A	ROLLER	(x2)	
	26	LV33612-001A	LOADING GEAR		
	27	QYWFM124013	WASHER	4mm/1.2mm x 0.13mm	
	28	LV43053-002A	ROD(L)		
	29	LV43725-001A	ROD(R)		
	30	LV43001-001A	COLLAR	(x2)	
	31	LV21285-002A	PROTECTOR		
	32	LV43055-001A	PROTECTOR SP.		
	33	QAR0144-003	MOTOR		
	34	LV43002-002A	WORM GEAR		
	35	QYSPSPT2025MA	SCREW	M2 x 2.5mm(x2)	
	36	LV33679-001A	MOTOR H. ASSY		
	37	LV33614-002A	WORM WHEEL		
	38	QYWDL1230250	SLIT WASHER	3mm/1.2mm x 0.25mm	
	39	VKZ4539-056	MINI SCREW	(x2)	
	40	LV33615-001A	GEAR 2		
	41	LV43057-003A	IDLER ARM ASSY		
	42	QYWDL1635252	SLIT WASHER	3.5mm/1.6mm x 0.25mm	
	43	LV21286-001A	CONTROL CAM		
	44	QYWDL1230250	SLIT WASHER	3mm/1.2mm x 0.25mm	
	45	LV33616-001A	LOAD.LOCK LEVER		
	46	LV43060-001A	CAM SPRING		
	47	LV43005-001A	GEAR 4		
	48	LV43006-001A	GEAR 5		
	49	LV33617-001A	GEAR 6		
	50	LV33618-002A	LOADING G. ARM		
	51	QYWDL1635252	SLIT WASHER	3.5mm/1.6mm x 0.25mm	
	52	LV43007-001A	GEAR 7		
	53	LV33619-002A	GEAR 8		
	54	LV42132-001A	E RING		
	55	QYWFM215013	WASHER	5mm/2.1mm x 0.13mm	
	56	LV33620-001A	GEAR 9		
	57	LV43008-001A	GEAR10		
	58	LV43061-001A	LOAD SPRING		
	59	LV33621-001A	FEED GEAR		
	60	LV33622-001A	TRIGGER ARM		
	61	LV43062-001A	FEED TRI.SPRING		
	62	QYSPSFT2040ZA	TAP SCREW	M2 x 4mm	
	63	QAR0305-001	SPINDLE MOTOR		
	64	QYSPSPT1720MA	SCREW	M1.7 x 2mm(x2)	
	65	LV43669-002A	T.TABLE ASSY		
	66	QYWFM214025	WASHER	4mm/2.1mm x 0.25mm	
	67	QAL0563-001	PICK UP		
	68	LV34583-002A	CD RACK PLATE		
	69	LV34579-001A	CD RACK SPRING		
	70	LV43903-002A	MINI TAP SCREW		
	71	LV34580-001A	P.S.SPRING		
	72	QYSPSGT1425MA	TAP SCREW	M1.4 x 2.5mm	
	73	LV43670-001A	LEAD SCREW		
	74	LV43010-001A	L.S.GEAR		

Symbol No.	Part No.	Part Name	Description	Local
75	LV43011-001A	THRUST SPRING		
76	QYSPSFT2040ZA	TAP SCREW	M2 x 4mm	
77	LV21604-004A	L.S.HOLDER 1		
78	VKZ4539-056	MINI SCREW	(x2)	
79	LV34582-002A	L.S.HOLDER 2		
80	VKZ4539-056	MINI SCREW	(x2)	
81	LV34581-002A	SUB GUIDE		
82	VKZ4539-056	MINI SCREW	(x3)	
83	LV34915-001A	SW LEVER		
84	LV43898-001A	S.L.SPRING		
85	QYSPSFT2040ZA	TAP SCREW	M2 x 4mm	
86	LV34602-002A	CLAMPER UNIT 2		
87	LV34585-001A	KICK ARM 2		
88	LV43507-001A	SPL WASHER		
89	LV43070-001A	CLAMPER SPRING		
90	LV43355-001A	CLAMPER2 SPRING		
91	LV30225-0J6A	SPACER		
92	LV21616-003A	FRONT UNIT 2		
93	VKZ4539-056	MINI SCREW		
94	LVB30016-001A	SW FPC2		
95	NSW0187-001	SWITCH		
96	NSW0187-001	SWITCH		
97	NSW0187-001	SWITCH		
98	VKZ4539-055	MINI SCREW	(x2)	
99	LV34916-001A	WIRE CLAMP	(x2)	

Electrical parts list

Main board (KD-LHX551/552)

Block No. [0][1]

△ Symbol No.	Part No.	Part Name	Description	Local
IC10	SAF7730HV/N224A	IC		
IC11	PHK04P02T-X	POWER MOS FET		
IC171	NJM2160BV-X	IC		
IC191	NJM4565V-X	IC		
IC271	NJM2160BV-X	IC		
IC291	NJM4565V-X	IC		
IC361	NJM4580V-X	IC		
IC365	BD3805F-X	IC		
IC381	NJM4565V-X	IC		
IC382	NJM2160BV-X	IC		
IC401	MR27T1602F247TN	IC		
IC402	MSM6650G3-BK	IC		
IC701	MN101E01MDT	IC		
IC702	PST9121N-X	IC		
IC703	BR24L32F-W-X	IC		
IC710	SN74AHCT126PW-X	IC(DIGITAL)		
IC901	HA13164A	IC		
IC951	TB2901HQ	IC		
IC971	BD9781HFP-W	DC CONVERTOR		
IC973	BD3930FP-X	IC		
IC975	BA33BC0FP-X	IC		
IC991	BA6956AN	IC		
Q1	2SB624/4-X	TRANSISTOR		
Q2	UN2211-X	TRANSISTOR		
Q30	UN2211-X	TRANSISTOR		
Q703	UN2213-X	DIGI TRANSISTOR		
Q901	UN2111-X	TRANSISTOR		
Q902	UN2211-X	TRANSISTOR		
Q903	2SB709A/QR/-X	TRANSISTOR		
Q907	UN2111-X	TRANSISTOR		
Q908	UN2211-X	TRANSISTOR		
Q941	UN2111-X	TRANSISTOR		
Q942	UN2113-X	DIGI TRANSISTOR		
Q951	2SD601A/QR/-X	TRANSISTOR		
Q952	UN2211-X	TRANSISTOR		
Q953	UN2213-X	DIGI TRANSISTOR		
Q954	UN2113-X	TRANSISTOR		
Q991	UN2211-X	TRANSISTOR		
Q1451	KTD1304-X	TRANSISTOR		
Q1452	KTD1304-X	TRANSISTOR		
Q2451	KTD1304-X	TRANSISTOR		
Q2452	KTD1304-X	TRANSISTOR		
Q3801	KTD1304-X	TRANSISTOR		
Q3802	UN2111-X	TRANSISTOR		
Q4002	2SD1781K/QR/-X	TRANSISTOR		
Q4003	2SD1781K/QR/-X	TRANSISTOR		
Q4101	2SD1383K/B/-X	TRANSISTOR		
Q4151	2SD1383K/B/-X	TRANSISTOR		
Q4201	2SD1383K/B/-X	TRANSISTOR		
Q4251	2SD1383K/B/-X	TRANSISTOR		
Q7201	UN2211-X	TRANSISTOR		
Q7202	UN2211-X	TRANSISTOR		
Q7503	UN2211-X	TRANSISTOR		
Q7504	2SB624/4-X	TRANSISTOR		
Q9001	2SD601A/QR/-X	TRANSISTOR		
Q9051	UN2211-X	TRANSISTOR		
D701	MA111-X	SI DIODE		
D702	MA111-X	SI DIODE		
D703	MA111-X	SI DIODE		
D704	MA111-X	SI DIODE		
D705	MA8062/M/-X	Z DIODE		
D706	MA111-X	SI DIODE		
D718	SML-310LT/MN/-X	LED		
D719	SML-310LT/MN/-X	LED		
D720	SML-310LT/MN/-X	LED		
D901	1N5401-F64	DIODE		
D904	RB160M-30-X	SB DIODE		
D905	RB160M-30-X	SB DIODE		
D941	UDZS11B-X	Z DIODE		
D942	MA152WA-X	DIODE		

△ Symbol No.	Part No.	Part Name	Description	Local
D943	MA152WA-X	DIODE		
D944	UDZS3.3B-X	Z DIODE		
D945	MA111-X	SI DIODE		
D952	UDZS11B-X	Z DIODE		
D961	RB160M-30-X	SB DIODE		
D962	RB160M-30-X	SB DIODE		
D963	RB160M-30-X	SB DIODE		
D964	RB160M-30-X	SB DIODE		
D965	RB160M-30-X	SB DIODE		
D966	RB160M-30-X	SB DIODE		
D967	RB160M-30-X	SB DIODE		
D968	RB160M-30-X	SB DIODE		
D971	1SR154-400-X	DIODE		
D972	RB051L-40-X	SB DIODE		
D973	1SR154-400-X	DIODE		
D974	RB160M-30-X	SB DIODE		
D991	UDZS3.9B-X	Z DIODE		
D1451	MA152WA-X	DIODE		
D2451	MA152WA-X	DIODE		
D3901	UDZS4.7B-X	Z DIODE		
D3921	UDZS4.7B-X	Z DIODE		
D4001	MA111-X	SI DIODE		
D7501	SIR-34ST3F	SI DIODE		
D9051	MA152WA-X	DIODE		
C2	QERF1CM-476Z	E CAPACITOR	47uF 16V M	
C3	NCB31HK-391X	C CAPACITOR	390pF 50V K	
C4	QERF1CM-476Z	E CAPACITOR	47uF 16V M	
C5	NCB31HK-391X	C CAPACITOR	390pF 50V K	
C13	NCB31HK-391X	C CAPACITOR	390pF 50V K	
C30	NCB31CK-473X	C CAPACITOR	0.047uF 16V K	
C31	NCB31CK-473X	C CAPACITOR	0.047uF 16V K	
C32	NDC31HJ-100X	C CAPACITOR	10pF 50V J	
C33	NDC31HJ-100X	C CAPACITOR	10pF 50V J	
C34	QERF1EM-475Z	E CAPACITOR	4.7uF 25V M	
C35	NCB31CK-104X	C CAPACITOR	0.1uF 16V K	
C36	NCS31HJ-181X	C CAPACITOR	180pF 50V J	
C37	NCB31HK-103X	C CAPACITOR	0.01uF 50V K	
C38	NCB31HK-102X	C CAPACITOR	1000pF 50V K	
C39	NCB31HK-102X	C CAPACITOR	1000pF 50V K	
C40	NDC31HJ-101X	C CAPACITOR	100pF 50V J	
C41	NCB31CK-104X	C CAPACITOR	0.1uF 16V K	
C42	NCB31CK-104X	C CAPACITOR	0.1uF 16V K	
C43	NCB31CK-104X	C CAPACITOR	0.1uF 16V K	
C44	QERF1EM-475Z	E CAPACITOR	4.7uF 25V M	
C45	NBE20JM-475X	TA E CAPACITOR	4.7uF 6.3V M	
C46	NCB31CK-104X	C CAPACITOR	0.1uF 16V K	
C47	NBE20JM-475X	TA E CAPACITOR	4.7uF 6.3V M	
C48	NEA70JM-107X	E CAPACITOR	100uF 6.3V M	
C50	NBE20JM-226X	TA E CAPACITOR	22uF 6.3V M	
C51	NCB31CK-473X	C CAPACITOR	0.047uF 16V K	
C52	NCB31CK-473X	C CAPACITOR	0.047uF 16V K	
C53	NBE21CM-105X	TA E CAPACITOR	1uF 16V M	
C54	QERF0JM-476Z	E CAPACITOR	47uF 6.3V M	
C55	NCB31CK-104X	C CAPACITOR	0.1uF 16V K	
C56	NDC31HJ-101X	C CAPACITOR	100pF 50V J	
C57	NDC31HJ-101X	C CAPACITOR	100pF 50V J	
C58	NEA70GM-107X	E CAPACITOR	100uF 4V M	
C59	NCB31CK-333X	C CAPACITOR	0.033uF 16V K	
C60	NCB31CK-104X	C CAPACITOR	0.1uF 16V K	
C61	QERF0JM-107Z	E CAPACITOR	100uF 6.3V M	
C62	QERF0JM-227Z	E CAPACITOR	220uF 6.3V M	
C63	NCB31EK-223X	C CAPACITOR	0.022uF 25V K	
C64	NCB21CK-105X	C CAPACITOR	1uF 16V K	
C65	NCB31HK-471X	C CAPACITOR	470pF 50V K	
C66	NDC31HJ-101X	C CAPACITOR	100pF 50V J	
C67	NDC31HJ-101X	C CAPACITOR	100pF 50V J	
C68	NDC31HJ-101X	C CAPACITOR	100pF 50V J	
C69	NCB31CK-473X	C CAPACITOR	0.047uF 16V K	
C70	NDC31HJ-101X	C CAPACITOR	100pF 50V J	
C71	NDC31HJ-101X	C CAPACITOR	100pF 50V J	
C75	NCB31CK-473X	C CAPACITOR	0.047uF 16V K	
C76	NCB31EK-223X	C CAPACITOR	0.022uF 25V K	
C80	NCB31EK-223X	C CAPACITOR	0.022uF 25V K	
C81	NCB31CK-473X	C CAPACITOR	0.047uF 16V K	
C82	NCB31EK-223X	C CAPACITOR	0.022uF 25V K	

Symbol No.	Part No.	Part Name	Description	Local	Symbol No.	Part No.	Part Name	Description	Local
C102	NCB31HK-103X	C CAPACITOR	0.01uF 50V K		C1552	NCB31HK-332X	C CAPACITOR	3300pF 50V K	
C103	NCB31HK-103X	C CAPACITOR	0.01uF 50V K		C1601	NDC31HJ-101X	C CAPACITOR	100pF 50V J	
C104	NCB31HK-103X	C CAPACITOR	0.01uF 50V K		C1602	NCB31HK-821X	C CAPACITOR	820pF 50V K	
C701	NDC31HJ-7R0X	C CAPACITOR	7pF 50V J		C1603	QTE1H55-225Z	E CAPACITOR	2.2uF 50V	
C702	NDC31HJ-7R0X	C CAPACITOR	7pF 50V J		C1604	NCS31HJ-121X	C CAPACITOR	120pF 50V J	
C703	NDC31HJ-330X	C CAPACITOR	33pF 50V J		C1605	QERF1EM-475Z	E CAPACITOR	4.7uF 25V M	
C704	NDC31HJ-180X	C CAPACITOR	18pF 50V J		C1606	QERF0JM-476Z	E CAPACITOR	47uF 6.3V M	
C705	QERF1CM-107Z	E CAPACITOR	100uF 16V M		C1651	QTE1H55-225Z	E CAPACITOR	2.2uF 50V	
C707	NDC31HJ-101X	C CAPACITOR	100pF 50V J		C1701	QERF1EM-475Z	E CAPACITOR	4.7uF 25V M	
C708	NBE21AM-106X	TA E CAPACITOR	10uF 10V M		C1702	NCB31CK-104X	C CAPACITOR	0.1uF 16V K	
C709	NCB31HK-103X	C CAPACITOR	0.01uF 50V K		C1703	QERF1AM-107Z	E CAPACITOR	100uF 10V M	
C710	NCB31CK-473X	C CAPACITOR	0.047uF 16V K		C1704	NCB31HK-152X	C CAPACITOR	1500pF 50V K	
C712	NCB31HK-103X	C CAPACITOR	0.01uF 50V K		C1705	NEA71HM-225X	E CAPACITOR	2.2uF 50V M	
C713	QERF0JM-337Z	E CAPACITOR	330uF 6.3V M		C1721	QERF1EM-475Z	E CAPACITOR	4.7uF 25V M	
C714	NCB31HK-103X	C CAPACITOR	0.01uF 50V K		C1722	NCB31CK-104X	C CAPACITOR	0.1uF 16V K	
C715	NCB31CK-104X	C CAPACITOR	0.1uF 16V K		C1723	QERF1AM-107Z	E CAPACITOR	100uF 10V M	
C716	NCB31HK-471X	C CAPACITOR	470pF 50V K		C1724	NCB31HK-152X	C CAPACITOR	1500pF 50V K	
C717	NCB31HK-103X	C CAPACITOR	0.01uF 50V K		C1725	NEA71HM-225X	E CAPACITOR	2.2uF 50V M	
C719	QERF0JM-337Z	E CAPACITOR	330uF 6.3V M		C1751	NFV81CM-105X	MF CAPACITOR	1uF 16V M	
C720	NCB31HK-103X	C CAPACITOR	0.01uF 50V K		C1752	NDC31HJ-101X	C CAPACITOR	100pF 50V J	
C721	NDC31HJ-101X	C CAPACITOR	100pF 50V J		C1771	NFV81CM-105X	MF CAPACITOR	1uF 16V M	
C776	NBE20JM-476X	TA E CAPACITOR	47uF 6.3V M		C1772	NDC31HJ-101X	C CAPACITOR	100pF 50V J	
C777	NCB31HK-103X	C CAPACITOR	0.01uF 50V K		C1801	NCB31CK-104X	C CAPACITOR	0.1uF 16V K	
C901	QEZ0723-338	E CAPACITOR	3300uF		C1901	QERF1EM-475Z	E CAPACITOR	4.7uF 25V M	
C902	NEA71CM-226X	E CAPACITOR	22uF 16V M		C1902	NCB21CK-105X	C CAPACITOR	1uF 16V K	
C903	NEA71CM-226X	E CAPACITOR	22uF 16V M		C1921	QERF1EM-475Z	E CAPACITOR	4.7uF 25V M	
C904	NCB31HK-103X	C CAPACITOR	0.01uF 50V K		C1922	NCB21CK-105X	C CAPACITOR	1uF 16V K	
C905	QERF1AM-107Z	E CAPACITOR	100uF 10V M		C2401	QERF1HM-225Z	E CAPACITOR	2.2uF 50V M	
C906	NCB31CK-104X	C CAPACITOR	0.1uF 16V K		C2402	NCB31HK-472X	C CAPACITOR	4700pF 50V K	
C907	NCB31HK-103X	C CAPACITOR	0.01uF 50V K		C2403	NDC31HJ-101X	C CAPACITOR	100pF 50V J	
C908	QERF1AM-227Z	E CAPACITOR	220uF 10V M		C2404	NCB31HK-102X	C CAPACITOR	1000pF 50V K	
C909	NBP21CM-106X	TA E CAPACITOR	10uF 16V M		C2451	NDC31HJ-101X	C CAPACITOR	100pF 50V J	
C910	NBP21CM-106X	TA E CAPACITOR	10uF 16V M		C2452	NDC31HJ-101X	C CAPACITOR	100pF 50V J	
C911	NCB31CK-104X	C CAPACITOR	0.1uF 16V K		C2501	NDC31HJ-101X	C CAPACITOR	100pF 50V J	
C912	NEA71HM-225X	E CAPACITOR	2.2uF 50V M		C2502	NCB30JK-105X	C CAPACITOR	1uF 6.3V K	
C941	QERF1CM-107Z	E CAPACITOR	100uF 16V M		C2552	NCB31HK-332X	C CAPACITOR	3300pF 50V K	
C942	QERF1CM-476Z	E CAPACITOR	47uF 16V M		C2601	NDC31HJ-101X	C CAPACITOR	100pF 50V J	
C943	QERF0JM-107Z	E CAPACITOR	100uF 6.3V M		C2602	NCB31HK-821X	C CAPACITOR	820pF 50V K	
C944	NBE20JM-106X	TA E CAPACITOR	10uF 6.3V M		C2603	QTE1H55-225Z	E CAPACITOR	2.2uF 50V	
C950	QERF1CM-476Z	E CAPACITOR	47uF 16V M		C2604	NCS31HJ-121X	C CAPACITOR	120pF 50V J	
C951	QERF1CM-226Z	E CAPACITOR	22uF 16V M		C2605	QERF1EM-475Z	E CAPACITOR	4.7uF 25V M	
C952	NCB31HK-103X	C CAPACITOR	0.01uF 50V K		C2606	QERF0JM-476Z	E CAPACITOR	47uF 6.3V M	
C953	QERF1CM-106Z	E CAPACITOR	10uF 16V M		C2651	QTE1H55-225Z	E CAPACITOR	2.2uF 50V	
C954	QERF1EM-475Z	E CAPACITOR	4.7uF 25V M		C2701	QERF1EM-475Z	E CAPACITOR	4.7uF 25V M	
C955	QERF1HM-225Z	E CAPACITOR	2.2uF 50V M		C2702	NCB31CK-104X	C CAPACITOR	0.1uF 16V K	
C971	NCB31CK-104X	C CAPACITOR	0.1uF 16V K		C2703	QERF1AM-107Z	E CAPACITOR	100uF 10V M	
C972	QERF1CM-107Z	E CAPACITOR	100uF 16V M		C2704	NCB31HK-152X	C CAPACITOR	1500pF 50V K	
C973	NCB31CK-104X	C CAPACITOR	0.1uF 16V K		C2705	NEA71HM-225X	E CAPACITOR	2.2uF 50V M	
C974	NCB31HK-104X	C CAPACITOR	0.1uF 50V K		C2721	QERF1EM-475Z	E CAPACITOR	4.7uF 25V M	
C975	NCB31HK-472X	C CAPACITOR	4700pF 50V K		C2722	NCB31CK-104X	C CAPACITOR	0.1uF 16V K	
C983	QERF1CM-107Z	E CAPACITOR	100uF 16V M		C2723	QERF1AM-107Z	E CAPACITOR	100uF 10V M	
C984	NCB31HK-103X	C CAPACITOR	0.01uF 50V K		C2724	NCB31HK-152X	C CAPACITOR	1500pF 50V K	
C985	QERF0JM-337Z	E CAPACITOR	330uF 6.3V M		C2725	NEA71HM-225X	E CAPACITOR	2.2uF 50V M	
C987	QEXL1AM-476Z	E CAPACITOR	47uF 10V M		C2751	NFV81CM-105X	MF CAPACITOR	1uF 16V M	
C988	NCB31HK-103X	C CAPACITOR	0.01uF 50V K		C2752	NDC31HJ-101X	C CAPACITOR	100pF 50V J	
C989	QERF0JM-107Z	E CAPACITOR	100uF 6.3V M		C2771	NFV81CM-105X	MF CAPACITOR	1uF 16V M	
C991	QERF1AM-107Z	E CAPACITOR	100uF 10V M		C2772	NDC31HJ-101X	C CAPACITOR	100pF 50V J	
C992	NCB31CK-473X	C CAPACITOR	0.047uF 16V K		C2801	NCB31CK-224X	C CAPACITOR	0.22uF 16V K	
C1001	NCB31HK-103X	C CAPACITOR	0.01uF 50V K		C2901	QERF1EM-475Z	E CAPACITOR	4.7uF 25V M	
C1003	NBE20JM-106X	TA E CAPACITOR	10uF 6.3V M		C2902	NCB21CK-105X	C CAPACITOR	1uF 16V K	
C1004	NBE20JM-106X	TA E CAPACITOR	10uF 6.3V M		C2921	QERF1EM-475Z	E CAPACITOR	4.7uF 25V M	
C1005	NBE20JM-476X	TA E CAPACITOR	47uF 6.3V M		C2922	NCB21CK-105X	C CAPACITOR	1uF 16V K	
C1006	NCB31CK-104X	C CAPACITOR	0.1uF 16V K		C3401	NEA71CM-476X	E CAPACITOR	47uF 16V M	
C1007	NCB31CK-104X	C CAPACITOR	0.1uF 16V K		C3402	NCB31CK-473X	C CAPACITOR	0.047uF 16V K	
C1008	NBE20JM-476X	TA E CAPACITOR	47uF 6.3V M		C3403	NCB31CK-473X	C CAPACITOR	0.047uF 16V K	
C1009	NCB31CK-473X	C CAPACITOR	0.047uF 16V K		C3451	NCB31CK-473X	C CAPACITOR	0.047uF 16V K	
C1010	NCB31CK-473X	C CAPACITOR	0.047uF 16V K		C3452	NCB31HK-102X	C CAPACITOR	1000pF 50V K	
C1011	NBE20JM-106X	TA E CAPACITOR	10uF 6.3V M		C3501	NCB31CK-473X	C CAPACITOR	0.047uF 16V K	
C1012	NCB31CK-473X	C CAPACITOR	0.047uF 16V K		C3601	QERF1CM-476Z	E CAPACITOR	47uF 16V M	
C1013	NCB31CK-473X	C CAPACITOR	0.047uF 16V K		C3651	QERF1CM-106Z	E CAPACITOR	10uF 16V M	
C1401	QERF1HM-225Z	E CAPACITOR	2.2uF 50V M		C3652	NCB31CK-104X	C CAPACITOR	0.1uF 16V K	
C1402	NCB31HK-472X	C CAPACITOR	4700pF 50V K		C3653	NBE21AM-106X	TA E CAPACITOR	10uF 10V M	
C1403	NDC31HJ-101X	C CAPACITOR	100pF 50V J		C3701	NBE20JM-226X	TA E CAPACITOR	22uF 6.3V M	
C1404	NCB31HK-102X	C CAPACITOR	1000pF 50V K		C3702	QERF1AM-476Z	E CAPACITOR	47uF 10V M	
C1451	NDC31HJ-101X	C CAPACITOR	100pF 50V J		C3721	NBE20JM-226X	TA E CAPACITOR	22uF 6.3V M	
C1452	NDC31HJ-101X	C CAPACITOR	100pF 50V J		C3722	QERF1AM-476Z	E CAPACITOR	47uF 10V M	
C1501	NDC31HJ-101X	C CAPACITOR	100pF 50V J		C3801	NCB31HK-332X	C CAPACITOR	3300pF 50V K	
C1502	NCB30JK-105X	C CAPACITOR	1uF 6.3V K		C3802	NEA71HM-105X	E CAPACITOR	1uF 50V M	

△ Symbol No.	Part No.	Part Name	Description	Local	△ Symbol No.	Part No.	Part Name	Description	Local
C3803	NCB31HK-104X	C CAPACITOR	0.1uF 50V K		R708	NRSA63J-273X	MG RESISTOR	27kΩ 1/16W J	
C3804	NEA71HM-225X	E CAPACITOR	2.2uF 50V M		R711	NRSA63J-563X	MG RESISTOR	56kΩ 1/16W J	
C3805	NBE20JM-476X	TA E CAPACITOR	47uF 6.3V M		R715	NRSA63J-102X	MG RESISTOR	1kΩ 1/16W J	
C3806	NCB31HK-822X	C CAPACITOR	8200pF 50V K		R716	NRSA63J-102X	MG RESISTOR	1kΩ 1/16W J	
C3807	NCB31CK-473X	C CAPACITOR	0.047uF 16V K		R717	NRSA63J-102X	MG RESISTOR	1kΩ 1/16W J	
C3808	NCB31HK-152X	C CAPACITOR	1500pF 50V K		R718	NRSA63J-0R0X	MG RESISTOR	0Ω 1/16W J	
C3809	NBE20JM-226X	TA E CAPACITOR	22uF 6.3V M		R720	NRSA63J-102X	MG RESISTOR	1kΩ 1/16W J	
C3810	QERF1AM-107Z	E CAPACITOR	100uF 10V M		R721	NRSA63J-102X	MG RESISTOR	1kΩ 1/16W J	
C3811	NEA71HM-225X	E CAPACITOR	2.2uF 50V M		R722	NRSA63J-101X	MG RESISTOR	100Ω 1/16W J	
C3901	QERF1AM-476Z	E CAPACITOR	47uF 10V M		R723	NRSA63J-101X	MG RESISTOR	100Ω 1/16W J	
C3902	QERF0JM-476Z	E CAPACITOR	47uF 6.3V M		R724	NRSA63J-101X	MG RESISTOR	100Ω 1/16W J	
C3922	QERF0JM-476Z	E CAPACITOR	47uF 6.3V M		R725	NRSA63J-103X	MG RESISTOR	10kΩ 1/16W J	
C4001	QERF0JM-107Z	E CAPACITOR	100uF 6.3V M		R726	NRSA63J-104X	MG RESISTOR	100kΩ 1/16W J	
C4002	NCB31EK-273X	C CAPACITOR	0.027uF 25V K		R729	NRSA63J-102X	MG RESISTOR	1kΩ 1/16W J	
C4004	NDC31HJ-390X	C CAPACITOR	39pF 50V J		R730	NRSA63J-102X	MG RESISTOR	1kΩ 1/16W J	
C4005	NDC31HJ-390X	C CAPACITOR	39pF 50V J		R731	NRSA63J-0R0X	MG RESISTOR	0Ω 1/16W J	
C4006	NCB31CK-473X	C CAPACITOR	0.047uF 16V K		R732	NRSA63J-0R0X	MG RESISTOR	0Ω 1/16W J	
C4007	NCB31CK-473X	C CAPACITOR	0.047uF 16V K		R733	NRSA63J-102X	MG RESISTOR	1kΩ 1/16W J	
C4008	NEA71CM-476X	E CAPACITOR	47uF 16V M		R734	NRSA63J-271X	MG RESISTOR	270Ω 1/16W J	
C4009	NCB31HK-102X	C CAPACITOR	1000pF 50V K		R735	NRSA63J-103X	MG RESISTOR	10kΩ 1/16W J	
C4010	NBE20JM-106X	TA E CAPACITOR	10uF 6.3V M		R736	NRSA63J-271X	MG RESISTOR	270Ω 1/16W J	
C4011	NCB31HK-103X	C CAPACITOR	0.01uF 50V K		R737	NRSA63J-102X	MG RESISTOR	1kΩ 1/16W J	
C4012	NBE20JM-106X	TA E CAPACITOR	10uF 6.3V M		R738	NRSA63J-102X	MG RESISTOR	1kΩ 1/16W J	
C4101	NCB31CK-104X	C CAPACITOR	0.1uF 16V K		R739	NRSA63J-104X	MG RESISTOR	100kΩ 1/16W J	
C4102	NCB31HK-392X	C CAPACITOR	3900pF 50V K		R741	NRSA63J-102X	MG RESISTOR	1kΩ 1/16W J	
C4151	NCB31CK-104X	C CAPACITOR	0.1uF 16V K		R742	NRSA63J-102X	MG RESISTOR	1kΩ 1/16W J	
C4152	NCB31HK-392X	C CAPACITOR	3900pF 50V K		R743	NRSA63J-102X	MG RESISTOR	1kΩ 1/16W J	
C4201	NCB31CK-104X	C CAPACITOR	0.1uF 16V K		R744	NRSA63J-102X	MG RESISTOR	1kΩ 1/16W J	
C4202	NCB31HK-392X	C CAPACITOR	3900pF 50V K		R745	NRSA63J-102X	MG RESISTOR	1kΩ 1/16W J	
C4251	NCB31CK-104X	C CAPACITOR	0.1uF 16V K		R746	NRSA63J-102X	MG RESISTOR	1kΩ 1/16W J	
C4252	NCB31HK-392X	C CAPACITOR	3900pF 50V K		R747	NRSA63J-473X	MG RESISTOR	47kΩ 1/16W J	
C7001	QERF0JM-337Z	E CAPACITOR	330uF 6.3V M		R749	NRSA63J-102X	MG RESISTOR	1kΩ 1/16W J	
C7002	QERF0JM-337Z	E CAPACITOR	330uF 6.3V M		R750	NRSA63J-102X	MG RESISTOR	1kΩ 1/16W J	
C7003	NCB31HK-103X	C CAPACITOR	0.01uF 50V K		R751	NRSA63J-123X	MG RESISTOR	12kΩ 1/16W J	
C7101	NCB31HK-103X	C CAPACITOR	0.01uF 50V K		R752	NRSA63J-102X	MG RESISTOR	1kΩ 1/16W J	
C7201	NCB31HK-103X	C CAPACITOR	0.01uF 50V K		R754	NRSA63J-223X	MG RESISTOR	22kΩ 1/16W J	
C7202	NCB31HK-103X	C CAPACITOR	0.01uF 50V K		R755	NRSA63J-221X	MG RESISTOR	220Ω 1/16W J	
C7203	NCB31HK-103X	C CAPACITOR	0.01uF 50V K		R756	NRSA63J-221X	MG RESISTOR	220Ω 1/16W J	
C7204	NCB31HK-103X	C CAPACITOR	0.01uF 50V K		R757	NRSA63J-102X	MG RESISTOR	1kΩ 1/16W J	
C9001	QERF1CM-106Z	E CAPACITOR	10uF 16V M		R758	NRSA63J-473X	MG RESISTOR	47kΩ 1/16W J	
C9051	NCB31CK-104X	C CAPACITOR	0.1uF 16V K		R759	NRSA63J-102X	MG RESISTOR	1kΩ 1/16W J	
R2	NRSA63J-101X	MG RESISTOR	100Ω 1/16W J		R760	NRSA63J-102X	MG RESISTOR	1kΩ 1/16W J	
R3	NRSA63J-0R0X	MG RESISTOR	0Ω 1/16W J		R761	NRSA63J-0R0X	MG RESISTOR	0Ω 1/16W J	
R4	NRSA63J-0R0X	MG RESISTOR	0Ω 1/16W J		R762	NRSA63J-102X	MG RESISTOR	1kΩ 1/16W J	
R7	NRSA63J-101X	MG RESISTOR	100Ω 1/16W J		R763	NRSA63J-102X	MG RESISTOR	1kΩ 1/16W J	
R8	NRSA63J-101X	MG RESISTOR	100Ω 1/16W J		R764	NRSA63J-102X	MG RESISTOR	1kΩ 1/16W J	
R9	NRSA63J-273X	MG RESISTOR	27kΩ 1/16W J		R765	NRSA63J-102X	MG RESISTOR	1kΩ 1/16W J	
R10	NRSA63J-273X	MG RESISTOR	27kΩ 1/16W J		R766	NRSA63J-102X	MG RESISTOR	1kΩ 1/16W J	
R11	NRS181J-100X	MG RESISTOR	10Ω 1/8W J		R767	NRSA63J-102X	MG RESISTOR	1kΩ 1/16W J	
R12	NRSA63J-103X	MG RESISTOR	10kΩ 1/16W J		R768	NRSA63J-224X	MG RESISTOR	220kΩ 1/16W J	
R13	NRSA63J-102X	MG RESISTOR	1kΩ 1/16W J		R769	NRSA63J-224X	MG RESISTOR	220kΩ 1/16W J	
R40	NRSA63J-101X	MG RESISTOR	100Ω 1/16W J		R770	NRSA63J-224X	MG RESISTOR	220kΩ 1/16W J	
R41	NRSA63J-100X	MG RESISTOR	10Ω 1/16W J		R771	NRSA63J-561X	MG RESISTOR	560Ω 1/16W J	
R42	NRSA63J-222X	MG RESISTOR	2.2kΩ 1/16W J		R772	NRSA63J-561X	MG RESISTOR	560Ω 1/16W J	
R43	NRSA63J-222X	MG RESISTOR	2.2kΩ 1/16W J		R774	NRSA63J-473X	MG RESISTOR	47kΩ 1/16W J	
R44	NRSA63J-0R0X	MG RESISTOR	0Ω 1/16W J		R775	NRSA63J-222X	MG RESISTOR	2.2kΩ 1/16W J	
R45	NRSA02J-0R0X	MG RESISTOR	0Ω 1/10W J		R776	NRSA63J-222X	MG RESISTOR	2.2kΩ 1/16W J	
R46	NRS181J-0R0X	MG RESISTOR	0Ω 1/8W J		R777	NRSA63J-473X	MG RESISTOR	47kΩ 1/16W J	
R49	NRSA63J-103X	MG RESISTOR	10kΩ 1/16W J		R784	NRSA63J-102X	MG RESISTOR	1kΩ 1/16W J	
R60	NRSA02J-100X	MG RESISTOR	10Ω 1/10W J		R788	NRSA63J-473X	MG RESISTOR	47kΩ 1/16W J	
R63	NRSA63J-101X	MG RESISTOR	100Ω 1/16W J		R789	NRSA63J-473X	MG RESISTOR	47kΩ 1/16W J	
R64	NRSA63J-101X	MG RESISTOR	100Ω 1/16W J		R790	NRSA63J-473X	MG RESISTOR	47kΩ 1/16W J	
R65	NRSA63J-101X	MG RESISTOR	100Ω 1/16W J		R791	NRSA63J-473X	MG RESISTOR	47kΩ 1/16W J	
R66	NRSA63J-101X	MG RESISTOR	100Ω 1/16W J		R796	NRSA63J-0R0X	MG RESISTOR	0Ω 1/16W J	
R67	NRSA63J-101X	MG RESISTOR	100Ω 1/16W J		R901	NRSA63J-912X	MG RESISTOR	9.1kΩ 1/16W J	
R68	NRSA63J-101X	MG RESISTOR	100Ω 1/16W J		R902	NRSA63J-472X	MG RESISTOR	4.7kΩ 1/16W J	
R69	NRSA63J-101X	MG RESISTOR	100Ω 1/16W J		R903	NRSA63J-562X	MG RESISTOR	5.6kΩ 1/16W J	
R70	NRSA63J-101X	MG RESISTOR	100Ω 1/16W J		R904	NRSA63J-102X	MG RESISTOR	1kΩ 1/16W J	
R71	NRSA63J-101X	MG RESISTOR	100Ω 1/16W J		R905	NRSA63J-103X	MG RESISTOR	10kΩ 1/16W J	
R78	NRSA63J-101X	MG RESISTOR	100Ω 1/16W J		R908	NRSA63J-153X	MG RESISTOR	15kΩ 1/16W J	
R701	NRSA63J-181X	MG RESISTOR	180Ω 1/16W J		R909	NRSA63J-473X	MG RESISTOR	47kΩ 1/16W J	
R702	NRSA63J-473X	MG RESISTOR	47kΩ 1/16W J		R910	QRE142J-102X	C RESISTOR	1kΩ 1/4W J	
R703	NRSA63J-106X	MG RESISTOR	10MΩ 1/16W J		R912	NRS181J-222X	MG RESISTOR	2.2kΩ 1/8W J	
R704	NRSA63J-473X	MG RESISTOR	47kΩ 1/16W J		R913	NRSA63J-102X	MG RESISTOR	1kΩ 1/16W J	
R705	NRSA63J-221X	MG RESISTOR	220Ω 1/16W J		R918	NRSA63J-473X	MG RESISTOR	47kΩ 1/16W J	
R706	NRSA63J-102X	MG RESISTOR	1kΩ 1/16W J		R941	NRSA02J-101X	MG RESISTOR	100Ω 1/10W J	
R707	NRSA63J-221X	MG RESISTOR	220Ω 1/16W J		R951	NRSA63J-222X	MG RESISTOR	2.2kΩ 1/16W J	
					R952	NRSA63J-273X	MG RESISTOR	27kΩ 1/16W J	

△ Symbol No.	Part No.	Part Name	Description	Local	△ Symbol No.	Part No.	Part Name	Description	Local
R953	NRSA63J-103X	MG RESISTOR	10kΩ 1/16W J		R2705	NRSA63J-102X	MG RESISTOR	1kΩ 1/16W J	
R954	NRSA63J-0R0X	MG RESISTOR	0Ω 1/16W J		R2706	NRSA63J-104X	MG RESISTOR	100kΩ 1/16W J	
R955	NRSA63J-473X	MG RESISTOR	47kΩ 1/16W J		R2722	NRSA63J-243X	MG RESISTOR	24kΩ 1/16W J	
R956	NRSA63J-473X	MG RESISTOR	47kΩ 1/16W J		R2723	NRSA63J-473X	MG RESISTOR	47kΩ 1/16W J	
R971	NRSA63J-394X	MG RESISTOR	390kΩ 1/16W J		R2724	NRSA63J-363X	MG RESISTOR	36kΩ 1/16W J	
R972	NRSA63J-154X	MG RESISTOR	150kΩ 1/16W J		R2725	NRSA63J-102X	MG RESISTOR	1kΩ 1/16W J	
R973	NRSA63D-563X	MG RESISTOR	56kΩ 1/16W D		R2726	NRSA63J-104X	MG RESISTOR	100kΩ 1/16W J	
R974	NRSA63D-394X	MG RESISTOR	390kΩ 1/16W D		R2754	NRSA63J-102X	MG RESISTOR	1kΩ 1/16W J	
R975	NRSA63D-103X	MG RESISTOR	10kΩ 1/16W D		R2774	NRSA63J-102X	MG RESISTOR	1kΩ 1/16W J	
R976	NRSA63J-103X	MG RESISTOR	10kΩ 1/16W J		R2801	NRSA63J-101X	MG RESISTOR	100Ω 1/16W J	
R978	NRS181J-220X	MG RESISTOR	22Ω 1/8W J		R2901	NRSA63D-103X	MG RESISTOR	10kΩ 1/16W D	
R979	NRS181J-220X	MG RESISTOR	22Ω 1/8W J		R2902	NRSA63D-103X	MG RESISTOR	10kΩ 1/16W D	
R991	NRSA63J-102X	MG RESISTOR	1kΩ 1/16W J		R2903	NRSA63J-154X	MG RESISTOR	150kΩ 1/16W J	
R1009	NRSA02J-0R0X	MG RESISTOR	0Ω 1/10W J		R2904	NRSA63J-103X	MG RESISTOR	10kΩ 1/16W J	
R1401	NRSA63J-682X	MG RESISTOR	6.8kΩ 1/16W J		R2905	NRSA63J-103X	MG RESISTOR	10kΩ 1/16W J	
R1402	NRSA63J-473X	MG RESISTOR	47kΩ 1/16W J		R2921	NRSA63D-103X	MG RESISTOR	10kΩ 1/16W D	
R1404	NRSA63J-123X	MG RESISTOR	12kΩ 1/16W J		R2922	NRSA63D-103X	MG RESISTOR	10kΩ 1/16W D	
R1451	NRSA63J-821X	MG RESISTOR	820Ω 1/16W J		R2923	NRSA63J-154X	MG RESISTOR	150kΩ 1/16W J	
R1452	NRSA63J-821X	MG RESISTOR	820Ω 1/16W J		R2924	NRSA63J-103X	MG RESISTOR	10kΩ 1/16W J	
R1453	NRSA63J-181X	MG RESISTOR	180Ω 1/16W J		R2925	NRSA63J-103X	MG RESISTOR	10kΩ 1/16W J	
R1454	NRSA63J-181X	MG RESISTOR	180Ω 1/16W J		R3401	NRSA63J-473X	MG RESISTOR	47kΩ 1/16W J	
R1455	NRSA63J-222X	MG RESISTOR	2.2kΩ 1/16W J		R3403	NRSA63J-471X	MG RESISTOR	470Ω 1/16W J	
R1456	NRSA63J-222X	MG RESISTOR	2.2kΩ 1/16W J		R3405	NRSA63J-100X	MG RESISTOR	10Ω 1/16W J	
R1501	NRSA63J-101X	MG RESISTOR	100Ω 1/16W J		R3653	NRSA63J-472X	MG RESISTOR	4.7kΩ 1/16W J	
R1502	NRSA63J-104X	MG RESISTOR	100kΩ 1/16W J		R3654	NRSA63J-103X	MG RESISTOR	10kΩ 1/16W J	
R1503	NRSA63J-682X	MG RESISTOR	6.8kΩ 1/16W J		R3655	NRSA63J-393X	MG RESISTOR	39kΩ 1/16W J	
R1504	NRSA63J-103X	MG RESISTOR	10kΩ 1/16W J		R3801	NRSA63J-104X	MG RESISTOR	100kΩ 1/16W J	
R1601	NRSA63J-203X	MG RESISTOR	20kΩ 1/16W J		R3802	NRSA63J-822X	MG RESISTOR	8.2kΩ 1/16W J	
R1602	NRSA63J-333X	MG RESISTOR	33kΩ 1/16W J		R3803	NRSA63J-273X	MG RESISTOR	27kΩ 1/16W J	
R1603	NRSA63J-123X	MG RESISTOR	12kΩ 1/16W J		R3804	NRSA63J-473X	MG RESISTOR	47kΩ 1/16W J	
R1604	NRSA63J-473X	MG RESISTOR	47kΩ 1/16W J		R3805	NRSA63J-821X	MG RESISTOR	820Ω 1/16W J	
R1605	NRSA63J-103X	MG RESISTOR	10kΩ 1/16W J		R3806	NRSA63J-363X	MG RESISTOR	36kΩ 1/16W J	
R1606	NRSA63J-103X	MG RESISTOR	10kΩ 1/16W J		R3807	NRSA63J-222X	MG RESISTOR	2.2kΩ 1/16W J	
R1702	NRSA63J-243X	MG RESISTOR	24kΩ 1/16W J		R3808	NRSA63J-103X	MG RESISTOR	10kΩ 1/16W J	
R1703	NRSA63J-473X	MG RESISTOR	47kΩ 1/16W J		R3809	NRSA63J-103X	MG RESISTOR	10kΩ 1/16W J	
R1704	NRSA63J-363X	MG RESISTOR	36kΩ 1/16W J		R3810	NRSA63J-0R0X	MG RESISTOR	0Ω 1/16W J	
R1705	NRSA63J-102X	MG RESISTOR	1kΩ 1/16W J		R3811	NRSA63J-243X	MG RESISTOR	24kΩ 1/16W J	
R1706	NRSA63J-104X	MG RESISTOR	100kΩ 1/16W J		R3901	NRSA63J-100X	MG RESISTOR	10Ω 1/16W J	
R1722	NRSA63J-243X	MG RESISTOR	24kΩ 1/16W J		R3902	NRSA63J-471X	MG RESISTOR	470Ω 1/16W J	
R1723	NRSA63J-473X	MG RESISTOR	47kΩ 1/16W J		R3922	NRSA63J-471X	MG RESISTOR	470Ω 1/16W J	
R1724	NRSA63J-363X	MG RESISTOR	36kΩ 1/16W J		R4013	NRSA63J-102X	MG RESISTOR	1kΩ 1/16W J	
R1725	NRSA63J-102X	MG RESISTOR	1kΩ 1/16W J		R4014	NRSA63J-102X	MG RESISTOR	1kΩ 1/16W J	
R1726	NRSA63J-104X	MG RESISTOR	100kΩ 1/16W J		R4015	NRSA63J-563X	MG RESISTOR	56kΩ 1/16W J	
R1754	NRSA63J-102X	MG RESISTOR	1kΩ 1/16W J		R4017	NRSA63J-102X	MG RESISTOR	1kΩ 1/16W J	
R1774	NRSA63J-102X	MG RESISTOR	1kΩ 1/16W J		R4021	NRSA63J-104X	MG RESISTOR	100kΩ 1/16W J	
R1801	NRSA63J-101X	MG RESISTOR	100Ω 1/16W J		R4023	NRSA63J-102X	MG RESISTOR	1kΩ 1/16W J	
R1901	NRSA63D-103X	MG RESISTOR	10kΩ 1/16W D		R4031	NRSA63J-102X	MG RESISTOR	1kΩ 1/16W J	
R1902	NRSA63D-103X	MG RESISTOR	10kΩ 1/16W D		R4032	NRSA63J-102X	MG RESISTOR	1kΩ 1/16W J	
R1903	NRSA63J-154X	MG RESISTOR	150kΩ 1/16W J		R4033	NRSA63J-102X	MG RESISTOR	1kΩ 1/16W J	
R1904	NRSA63J-103X	MG RESISTOR	10kΩ 1/16W J		R4034	NRSA63J-102X	MG RESISTOR	1kΩ 1/16W J	
R1905	NRSA63J-103X	MG RESISTOR	10kΩ 1/16W J		R4035	NRSA63J-473X	MG RESISTOR	47kΩ 1/16W J	
R1921	NRSA63D-103X	MG RESISTOR	10kΩ 1/16W D		R4036	NRSA63J-102X	MG RESISTOR	1kΩ 1/16W J	
R1922	NRSA63D-103X	MG RESISTOR	10kΩ 1/16W D		R4037	NRSA63J-102X	MG RESISTOR	1kΩ 1/16W J	
R1923	NRSA63J-154X	MG RESISTOR	150kΩ 1/16W J		R4038	NRSA63J-102X	MG RESISTOR	1kΩ 1/16W J	
R1924	NRSA63J-103X	MG RESISTOR	10kΩ 1/16W J		R4039	NRSA63J-102X	MG RESISTOR	1kΩ 1/16W J	
R1925	NRSA63J-103X	MG RESISTOR	10kΩ 1/16W J		R4040	NRSA63J-102X	MG RESISTOR	1kΩ 1/16W J	
R2401	NRSA63J-682X	MG RESISTOR	6.8kΩ 1/16W J		R4041	NRSA63J-102X	MG RESISTOR	1kΩ 1/16W J	
R2402	NRSA63J-473X	MG RESISTOR	47kΩ 1/16W J		R4042	NRSA63J-102X	MG RESISTOR	1kΩ 1/16W J	
R2404	NRSA63J-123X	MG RESISTOR	12kΩ 1/16W J		R4043	NRSA63J-102X	MG RESISTOR	1kΩ 1/16W J	
R2451	NRSA63J-821X	MG RESISTOR	820Ω 1/16W J		R4067	NRSA63J-0R0X	MG RESISTOR	0Ω 1/16W J	
R2452	NRSA63J-821X	MG RESISTOR	820Ω 1/16W J		R4069	NRSA63J-562X	MG RESISTOR	5.6kΩ 1/16W J	
R2453	NRSA63J-181X	MG RESISTOR	180Ω 1/16W J		R4070	NRSA63J-222X	MG RESISTOR	2.2kΩ 1/16W J	
R2454	NRSA63J-181X	MG RESISTOR	180Ω 1/16W J		R4071	NRSA63J-104X	MG RESISTOR	100kΩ 1/16W J	
R2455	NRSA63J-222X	MG RESISTOR	2.2kΩ 1/16W J		R4073	NRSA63J-222X	MG RESISTOR	2.2kΩ 1/16W J	
R2456	NRSA63J-222X	MG RESISTOR	2.2kΩ 1/16W J		R4100	NRSA02J-102X	MG RESISTOR	1kΩ 1/10W J	
R2501	NRSA63J-101X	MG RESISTOR	100Ω 1/16W J		R4101	NRSA63J-473X	MG RESISTOR	47kΩ 1/16W J	
R2502	NRSA63J-104X	MG RESISTOR	100kΩ 1/16W J		R4102	NRSA63J-224X	MG RESISTOR	220kΩ 1/16W J	
R2503	NRSA63J-682X	MG RESISTOR	6.8kΩ 1/16W J		R4103	NRSA63J-272X	MG RESISTOR	2.7kΩ 1/16W J	
R2504	NRSA63J-103X	MG RESISTOR	10kΩ 1/16W J		R4151	NRSA63J-473X	MG RESISTOR	47kΩ 1/16W J	
R2601	NRSA63J-203X	MG RESISTOR	20kΩ 1/16W J		R4152	NRSA63J-224X	MG RESISTOR	220kΩ 1/16W J	
R2602	NRSA63J-333X	MG RESISTOR	33kΩ 1/16W J		R4153	NRSA63J-272X	MG RESISTOR	2.7kΩ 1/16W J	
R2603	NRSA63J-123X	MG RESISTOR	12kΩ 1/16W J		R4201	NRSA63J-473X	MG RESISTOR	47kΩ 1/16W J	
R2604	NRSA63J-473X	MG RESISTOR	47kΩ 1/16W J		R4202	NRSA63J-224X	MG RESISTOR	220kΩ 1/16W J	
R2605	NRSA63J-103X	MG RESISTOR	10kΩ 1/16W J		R4203	NRSA63J-272X	MG RESISTOR	2.7kΩ 1/16W J	
R2606	NRSA63J-103X	MG RESISTOR	10kΩ 1/16W J		R4251	NRSA63J-473X	MG RESISTOR	47kΩ 1/16W J	
R2702	NRSA63J-243X	MG RESISTOR	24kΩ 1/16W J		R4252	NRSA63J-224X	MG RESISTOR	220kΩ 1/16W J	
R2703	NRSA63J-473X	MG RESISTOR	47kΩ 1/16W J		R4253	NRSA63J-272X	MG RESISTOR	2.7kΩ 1/16W J	
R2704	NRSA63J-363X	MG RESISTOR	36kΩ 1/16W J		R7002	NRSA63J-473X	MG RESISTOR	47kΩ 1/16W J	

△ Symbol No.	Part No.	Part Name	Description	Local	△ Symbol No.	Part No.	Part Name	Description	Local
R7101	NRSA63J-333X	MG RESISTOR	33kΩ 1/16W J		Q8704	2SD601A/QR/-X	TRANSISTOR		
R7102	NRSA63J-183X	MG RESISTOR	18kΩ 1/16W J		Q8705	UN2111-X	TRANSISTOR		
R7103	NRSA63J-0R0X	MG RESISTOR	0Ω 1/16W J		Q8751	2SD601A/QR/-X	TRANSISTOR		
R7104	NRSA63J-102X	MG RESISTOR	1kΩ 1/16W J		Q8752	2SD601A/QR/-X	TRANSISTOR		
R7105	NRSA63J-104X	MG RESISTOR	100kΩ 1/16W J		Q8753	2SD601A/QR/-X	TRANSISTOR		
R7106	NRSA63J-104X	MG RESISTOR	100kΩ 1/16W J		Q8754	2SD601A/QR/-X	TRANSISTOR		
R7107	NRSA63J-101X	MG RESISTOR	100Ω 1/16W J		Q8755	2SD601A/QR/-X	TRANSISTOR		
R7110	NRSA63J-101X	MG RESISTOR	100Ω 1/16W J		Q8756	2SD601A/QR/-X	TRANSISTOR		
R7111	NRSA63J-104X	MG RESISTOR	100kΩ 1/16W J		Q8757	2SD601A/QR/-X	TRANSISTOR		
R7112	NRSA63J-392X	MG RESISTOR	3.9kΩ 1/16W J		Q8758	2SD601A/QR/-X	TRANSISTOR		
R7113	NRSA63J-102X	MG RESISTOR	1kΩ 1/16W J		Q8759	2SD601A/QR/-X	TRANSISTOR		
R7116	NRSA63J-104X	MG RESISTOR	100kΩ 1/16W J		Q8760	2SD601A/QR/-X	TRANSISTOR		
R7117	NRSA63J-104X	MG RESISTOR	100kΩ 1/16W J		Q8761	2SD601A/QR/-X	TRANSISTOR		
R7118	NRSA63J-682X	MG RESISTOR	6.8kΩ 1/16W J		Q8762	2SD601A/QR/-X	TRANSISTOR		
R7119	NRSA63J-102X	MG RESISTOR	1kΩ 1/16W J		Q8763	2SD601A/QR/-X	TRANSISTOR		
R7120	NRSA02J-100X	MG RESISTOR	10Ω 1/10W J		Q8764	2SD601A/QR/-X	TRANSISTOR		
R7205	NRSA63J-0R0X	MG RESISTOR	0Ω 1/16W J		Q8765	2SD601A/QR/-X	TRANSISTOR		
R7501	NRS181J-181X	MG RESISTOR	180Ω 1/8W J		Q8766	2SD601A/QR/-X	TRANSISTOR		
R7504	NRSA63J-473X	MG RESISTOR	47kΩ 1/16W J		Q8767	2SD601A/QR/-X	TRANSISTOR		
R7505	NRSA63J-222X	MG RESISTOR	2.2kΩ 1/16W J		Q8768	2SD601A/QR/-X	TRANSISTOR		
R9001	NRSA63J-104X	MG RESISTOR	100kΩ 1/16W J		Q8770	2SD601A/QR/-X	TRANSISTOR		
R9002	NRSA63J-103X	MG RESISTOR	10kΩ 1/16W J		Q8771	2SD601A/QR/-X	TRANSISTOR		
R9003	NRSA63J-473X	MG RESISTOR	47kΩ 1/16W J		Q8772	2SD601A/QR/-X	TRANSISTOR		
R9051	NRSA63J-473X	MG RESISTOR	47kΩ 1/16W J		Q8773	2SD601A/QR/-X	TRANSISTOR		
R9052	NRSA63J-102X	MG RESISTOR	1kΩ 1/16W J		Q8774	2SD601A/QR/-X	TRANSISTOR		
L1	NQL334J-4R7X	COIL	4.7uH J		Q8775	2SD601A/QR/-X	TRANSISTOR		
L30	NQR0129-003X	FERRITE BESDA			Q8776	2SD601A/QR/-X	TRANSISTOR		
L31	NQL093K-2R2X	COIL	2.2uH K		Q8777	2SD601A/QR/-X	TRANSISTOR		
L40	NQR0129-003X	FERRITE BESDA			Q8778	2SD601A/QR/-X	TRANSISTOR		
L63	NQL093K-1R8X	COIL	1.8uH K		Q8779	2SD601A/QR/-X	TRANSISTOR		
L701	NQL79GM-470X	COIL	47uH M		Q8780	2SD601A/QR/-X	TRANSISTOR		
L702	NQL79GM-470X	COIL	47uH M		Q8781	2SD601A/QR/-X	TRANSISTOR		
L901	QQR1640-001	CHOKE COIL			D8001	MA152WK-X	SI DIODE		
L971	NQLB7GM-100X	COIL	10uH M		D8002	UDZS6.2B-X	Z DIODE		
L972	NQL71EM-330X	COIL	33uH M		D8003	UDZS6.2B-X	Z DIODE		
L4001	NQL79GM-470X	COIL	47uH M		D8004	UDZS6.2B-X	Z DIODE		
L7201	NQL79GM-470X	COIL	47uH M		D8005	UDZS6.2B-X	Z DIODE		
CN341	QGA2006C1-04	CONNECTOR	W-B (1-4)		D8006	UDZS6.2B-X	Z DIODE		
CN345	QNN0490-001	PIN JACK			D8007	UDZS6.2B-X	Z DIODE		
CN351	QNZ0095-001	CONNECTOR			D8008	UDZS6.2B-X	Z DIODE		
CN381	QGA2501C1-03	CONNECTOR	W-B (1-3)		D8009	UDZS6.2B-X	Z DIODE		
CN701	QGF1041C3-16W	CONNECTOR	FFC/FPC (1-16)		D8010	UDZS6.2B-X	Z DIODE		
CN702	QGA2006F1-02	CONNECTOR	W-B (1-2)		D8201	MA1111-X	SI DIODE		
CN721	QGB2027M5-20S	CONNECTOR	B-B (1-20)		D8203	MA152WA-X	DIODE		
CN901	QNZ0611-001	16P CONNECTOR			D8701	UDZS6.2B-X	Z DIODE		
CN991	QGA2501F1-02	CONNECTOR	W-B (1-2)		D8702	UDZS6.2B-X	Z DIODE		
CN992	QJB005-040909	SIN ID C-B WIRE			D8703	UDZS6.2B-X	Z DIODE		
J1	QAM0556-001	ANT CABLE			D8704	UDZS6.2B-X	Z DIODE		
PP2	QZW0010-001	STYLE PIN			D8731	NSCM315C/ZI-W	LED		
TU1	QAU0324-002	TUNER PUCK			D8732	NSCM315C/ZI-W	LED		
X1	QAX0781-001Z	CRYSTAL	41.600MHz		D8733	NSCM315C/ZI-W	LED		
X701	QAX0782-001Z	CRYSTAL	32.000MHz		D8734	NSCM315C/ZI-W	LED		
X702	QAX0401-001	CRYSTAL	32.768KHz		D8735	NSCM315C/ZI-W	LED		
X4001	QAX0763-001Z	C RESONATOR	4.19MHz		D8751	UDZS6.2B-X	Z DIODE		

Switch board (KD-LHX551/552)

Block No. [0][2]

△ Symbol No.	Part No.	Part Name	Description	Local	△ Symbol No.	Part No.	Part Name	Description	Local
IC801	MN102H60KDR	IC			D8752	UDZS6.2B-X	Z DIODE		
IC815	SG32M90TFIR3C01	IC			D8753	UDZS6.2B-X	Z DIODE		
IC821	IC-PST3424U-X	IC			D8754	UDZS6.2B-X	Z DIODE		
IC831	NJU7241F33-X	IC			D8755	UDZS6.2B-X	Z DIODE		
IC841	RPM7338-V4	RM.RECEIVER			D8756	UDZS6.2B-X	Z DIODE		
Q8001	2SB709A/QR/-X	TRANSISTOR			D8757	UDZS6.2B-X	Z DIODE		
Q8002	2SB709A/QR/-X	TRANSISTOR			D8758	UDZS6.2B-X	Z DIODE		
Q8301	2SD601A/QR/-X	TRANSISTOR			D8759	UDZS6.2B-X	Z DIODE		
Q8701	2SB709A/QR/-X	TRANSISTOR			D8760	UDZS6.2B-X	Z DIODE		
Q8702	2SB709A/QR/-X	TRANSISTOR			D8761	UDZS6.2B-X	Z DIODE		
Q8703	2SD601A/QR/-X	TRANSISTOR			D8762	UDZS6.2B-X	Z DIODE		
					D8763	UDZS6.2B-X	Z DIODE		
					D8764	UDZS6.2B-X	Z DIODE		
					D8765	UDZS6.2B-X	Z DIODE		
					D8801	MA152WK-X	SI DIODE		
					D8802	SML-310LT/MN/-X	LED		
					D8803	SML-310LT/MN/-X	LED		
					D8809	SML-310LT/MN/-X	LED		
					D8810	SML-310LT/MN/-X	LED		
					C8002	NBE20JM-106X	TA E CAPACITOR	10uF 6.3V M	
					C8003	NCB31CK-473X	C CAPACITOR	0.047uF 16V K	
					C8006	NCB31HK-471X	C CAPACITOR	470pF 50V K	

△ Symbol No.	Part No.	Part Name	Description	Local	△ Symbol No.	Part No.	Part Name	Description	Local
C8008	NCB31CK-473X	C CAPACITOR	0.047uF 16V K		R8028	NRSA63J-331X	MG RESISTOR	330Ω 1/16W J	
C8009	NBE20JM-475X	TA E CAPACITOR	4.7uF 6.3V M		R8029	NRSA63J-331X	MG RESISTOR	330Ω 1/16W J	
C8010	NBE20JM-475X	TA E CAPACITOR	4.7uF 6.3V M		R8030	NRSA63J-331X	MG RESISTOR	330Ω 1/16W J	
C8011	NBE20JM-475X	TA E CAPACITOR	4.7uF 6.3V M		R8031	NRSA63J-331X	MG RESISTOR	330Ω 1/16W J	
C8013	NCB31CK-473X	C CAPACITOR	0.047uF 16V K		R8032	NRSA63J-331X	MG RESISTOR	330Ω 1/16W J	
C8014	NDC31HJ-7R0X	C CAPACITOR	7pF 50V J		R8033	NRSA63J-331X	MG RESISTOR	330Ω 1/16W J	
C8015	NDC31HJ-7R0X	C CAPACITOR	7pF 50V J		R8034	NRSA63J-331X	MG RESISTOR	330Ω 1/16W J	
C8151	NBE20JM-106X	TA E CAPACITOR	10uF 6.3V M		R8035	NRSA63J-331X	MG RESISTOR	330Ω 1/16W J	
C8152	NCB31CK-473X	C CAPACITOR	0.047uF 16V K		R8036	NRSA63J-331X	MG RESISTOR	330Ω 1/16W J	
C8153	NCB31HK-471X	C CAPACITOR	470pF 50V K		R8037	NRSA63J-331X	MG RESISTOR	330Ω 1/16W J	
C8201	NBE20JM-475X	TA E CAPACITOR	4.7uF 6.3V M		R8038	NRSA63J-331X	MG RESISTOR	330Ω 1/16W J	
C8202	NCB31CK-473X	C CAPACITOR	0.047uF 16V K		R8039	NRSA63J-331X	MG RESISTOR	330Ω 1/16W J	
C8301	NBE20JM-106X	TA E CAPACITOR	10uF 6.3V M		R8040	NRSA63J-331X	MG RESISTOR	330Ω 1/16W J	
C8302	NCB31CK-473X	C CAPACITOR	0.047uF 16V K		R8041	NRSA63J-331X	MG RESISTOR	330Ω 1/16W J	
C8303	NBE20JM-106X	TA E CAPACITOR	10uF 6.3V M		R8042	NRSA63J-331X	MG RESISTOR	330Ω 1/16W J	
C8304	NBE21AM-106X	TA E CAPACITOR	10uF 10V M		R8043	NRSA63J-331X	MG RESISTOR	330Ω 1/16W J	
C8401	NBE21AM-475X	TA E CAPACITOR	4.7uF 10V M		R8044	NRSA63J-822X	MG RESISTOR	8.2kΩ 1/16W J	
C8502	NCB21CK-105X	C CAPACITOR	1uF 16V K		R8045	NRSA63J-331X	MG RESISTOR	330Ω 1/16W J	
C8503	NCB31CK-473X	C CAPACITOR	0.047uF 16V K		R8046	NRSA63J-331X	MG RESISTOR	330Ω 1/16W J	
C8504	NCB21CK-105X	C CAPACITOR	1uF 16V K		R8047	NRSA63J-331X	MG RESISTOR	330Ω 1/16W J	
C8505	NCJ31CK-105X-A	C CAPACITOR			R8048	NRSA63J-331X	MG RESISTOR	330Ω 1/16W J	
C8506	NCJ31CK-105X-A	C CAPACITOR			R8049	NRSA63J-331X	MG RESISTOR	330Ω 1/16W J	
C8507	NCB11EM-105X	C CAPACITOR	1uF 25V M		R8050	NRSA63J-104X	MG RESISTOR	100kΩ 1/16W J	
C8508	NCJ31CK-105X-A	C CAPACITOR			R8051	NRSA63J-104X	MG RESISTOR	100kΩ 1/16W J	
C8509	NCB11EM-105X	C CAPACITOR	1uF 25V M		R8052	NRSA63J-331X	MG RESISTOR	330Ω 1/16W J	
C8510	NCJ31CK-105X-A	C CAPACITOR			R8053	NRSA63J-104X	MG RESISTOR	100kΩ 1/16W J	
C8511	NCJ31CK-105X-A	C CAPACITOR			R8054	NRSA63J-104X	MG RESISTOR	100kΩ 1/16W J	
C8512	NCJ31CK-105X-A	C CAPACITOR			R8055	NRSA63J-103X	MG RESISTOR	10kΩ 1/16W J	
C8513	NCJ31CK-105X-A	C CAPACITOR			R8056	NRSA63J-103X	MG RESISTOR	10kΩ 1/16W J	
C8514	NCJ31CK-105X-A	C CAPACITOR			R8059	NRSA63J-102X	MG RESISTOR	1kΩ 1/16W J	
C8515	NCB31CK-473X	C CAPACITOR	0.047uF 16V K		R8060	NRSA63J-102X	MG RESISTOR	1kΩ 1/16W J	
C8516	NBE20JM-475X	TA E CAPACITOR	4.7uF 6.3V M		R8061	NRSA63J-102X	MG RESISTOR	1kΩ 1/16W J	
C8517	NCB11EM-105X	C CAPACITOR	1uF 25V M		R8062	NRSA63J-102X	MG RESISTOR	1kΩ 1/16W J	
C8518	NCJ31CK-105X-A	C CAPACITOR			R8063	NRSA63J-102X	MG RESISTOR	1kΩ 1/16W J	
C8519	NCJ31CK-105X-A	C CAPACITOR			R8064	NRSA63J-152X	MG RESISTOR	1.5kΩ 1/16W J	
C8520	NCJ31CK-105X-A	C CAPACITOR			R8065	NRSA63J-152X	MG RESISTOR	1.5kΩ 1/16W J	
C8521	NCJ31CK-105X-A	C CAPACITOR			R8066	NRSA63J-473X	MG RESISTOR	47kΩ 1/16W J	
C8522	NCJ31CK-105X-A	C CAPACITOR			R8067	NRSA63J-473X	MG RESISTOR	47kΩ 1/16W J	
C8701	NCB31HK-472X	C CAPACITOR	4700pF 50V K		R8069	NRSA63J-331X	MG RESISTOR	330Ω 1/16W J	
C8702	NCB31HK-472X	C CAPACITOR	4700pF 50V K		R8070	NRSA63J-473X	MG RESISTOR	47kΩ 1/16W J	
C8703	NCB31HK-821X	C CAPACITOR	820pF 50V K		R8071	NRSA63J-222X	MG RESISTOR	2.2kΩ 1/16W J	
C8704	NCB31HK-821X	C CAPACITOR	820pF 50V K		R8072	NRSA63J-331X	MG RESISTOR	330Ω 1/16W J	
C8731	NCB31CK-473X	C CAPACITOR	0.047uF 16V K		R8073	NRSA63J-331X	MG RESISTOR	330Ω 1/16W J	
C8732	NCB31CK-473X	C CAPACITOR	0.047uF 16V K		R8074	NRSA63J-331X	MG RESISTOR	330Ω 1/16W J	
C8733	NCB31CK-473X	C CAPACITOR	0.047uF 16V K		R8075	NRSA63J-331X	MG RESISTOR	330Ω 1/16W J	
C8734	NCB31CK-473X	C CAPACITOR	0.047uF 16V K		R8076	NRSA63J-331X	MG RESISTOR	330Ω 1/16W J	
C8735	NCB31CK-473X	C CAPACITOR	0.047uF 16V K		R8077	NRSA63J-331X	MG RESISTOR	330Ω 1/16W J	
C8736	NCB31CK-473X	C CAPACITOR	0.047uF 16V K		R8078	NRSA63J-331X	MG RESISTOR	330Ω 1/16W J	
C8737	NCB31CK-473X	C CAPACITOR	0.047uF 16V K		R8079	NRSA63J-331X	MG RESISTOR	330Ω 1/16W J	
C8738	NCB31CK-473X	C CAPACITOR	0.047uF 16V K		R8082	NRSA63J-331X	MG RESISTOR	330Ω 1/16W J	
C8739	NCB31CK-473X	C CAPACITOR	0.047uF 16V K		R8083	NRSA63J-331X	MG RESISTOR	330Ω 1/16W J	
C8740	NCB31CK-473X	C CAPACITOR	0.047uF 16V K		R8084	NRSA63J-331X	MG RESISTOR	330Ω 1/16W J	
C8742	NCB31CK-473X	C CAPACITOR	0.047uF 16V K		R8085	NRSA63J-331X	MG RESISTOR	330Ω 1/16W J	
C8743	NCB31CK-473X	C CAPACITOR	0.047uF 16V K		R8086	NRSA63J-331X	MG RESISTOR	330Ω 1/16W J	
C8744	NCB31CK-473X	C CAPACITOR	0.047uF 16V K		R8087	NRSA63J-331X	MG RESISTOR	330Ω 1/16W J	
C8745	NCB31CK-473X	C CAPACITOR	0.047uF 16V K		R8088	NRSA63J-331X	MG RESISTOR	330Ω 1/16W J	
R8001	NRSA63J-301X	MG RESISTOR	300Ω 1/16W J		R8095	NRS181J-0R0X	MG RESISTOR	0Ω 1/8W J	
R8002	NRSA63J-271X	MG RESISTOR	270Ω 1/16W J		R8097	NRSA63J-0R0X	MG RESISTOR	0Ω 1/16W J	
R8003	NRSA63J-391X	MG RESISTOR	390Ω 1/16W J		R8098	NRSA63J-0R0X	MG RESISTOR	0Ω 1/16W J	
R8004	NRSA63J-301X	MG RESISTOR	300Ω 1/16W J		R8152	NRS181J-0R0X	MG RESISTOR	0Ω 1/8W J	
R8005	NRSA63J-271X	MG RESISTOR	270Ω 1/16W J		R8153	NRSA63J-0R0X	MG RESISTOR	0Ω 1/16W J	
R8006	NRSA63J-103X	MG RESISTOR	10kΩ 1/16W J		R8201	NRSA63J-222X	MG RESISTOR	2.2kΩ 1/16W J	
R8007	NRSA63J-474X	MG RESISTOR	470kΩ 1/16W J		R8202	NRSA63J-473X	MG RESISTOR	47kΩ 1/16W J	
R8008	NRSA63J-473X	MG RESISTOR	47kΩ 1/16W J		R8203	NRSA63J-102X	MG RESISTOR	1kΩ 1/16W J	
R8009	NRSA63J-473X	MG RESISTOR	47kΩ 1/16W J		R8301	NRSA63J-104X	MG RESISTOR	100kΩ 1/16W J	
R8011	NRSA63J-331X	MG RESISTOR	330Ω 1/16W J		R8302	NRSA63J-474X	MG RESISTOR	470kΩ 1/16W J	
R8012	NRSA63J-331X	MG RESISTOR	330Ω 1/16W J		R8401	NRSA63J-470X	MG RESISTOR	47Ω 1/16W J	
R8013	NRSA63J-331X	MG RESISTOR	330Ω 1/16W J		R8402	NRSA63J-0R0X	MG RESISTOR	0Ω 1/16W J	
R8016	NRSA63J-331X	MG RESISTOR	330Ω 1/16W J		R8501	NRSA63J-0R0X	MG RESISTOR	0Ω 1/16W J	
R8021	NRSA63J-331X	MG RESISTOR	330Ω 1/16W J		R8705	NRSA63J-332X	MG RESISTOR	3.3kΩ 1/16W J	
R8022	NRSA63J-331X	MG RESISTOR	330Ω 1/16W J		R8708	NRSA63J-332X	MG RESISTOR	3.3kΩ 1/16W J	
R8023	NRSA63J-331X	MG RESISTOR	330Ω 1/16W J		R8711	NRSA63J-0R0X	MG RESISTOR	0Ω 1/16W J	
R8024	NRSA63J-331X	MG RESISTOR	330Ω 1/16W J		R8713	NRSA63J-332X	MG RESISTOR	3.3kΩ 1/16W J	
R8025	NRSA63J-331X	MG RESISTOR	330Ω 1/16W J		R8715	NRSA63J-102X	MG RESISTOR	1kΩ 1/16W J	
R8026	NRSA63J-680X	MG RESISTOR	68Ω 1/16W J		R8716	NRSA63J-102X	MG RESISTOR	1kΩ 1/16W J	
R8027	NRSA63J-473X	MG RESISTOR	47kΩ 1/16W J		R8718	NRSA63J-332X	MG RESISTOR	3.3kΩ 1/16W J	
					R8719	NRSA63J-822X	MG RESISTOR	8.2kΩ 1/16W J	
					R8720	NRSA63J-822X	MG RESISTOR	8.2kΩ 1/16W J	
					R8721	NRSA63J-103X	MG RESISTOR	10kΩ 1/16W J	

△ Symbol No.	Part No.	Part Name	Description	Local	△ Symbol No.	Part No.	Part Name	Description	Local
R8752	NRSA63J-391X	MG RESISTOR	390Ω 1/16W J		TH801	NAD0028-103X	N THERMISTOR	10kΩ	
R8753	NRSA63J-391X	MG RESISTOR	390Ω 1/16W J		X8001	NAX0652-001X	C RESONATOR	25.000MHz	
R8754	NRSA63J-391X	MG RESISTOR	390Ω 1/16W J		Mechanism control board (KD-LHX551/552) Block No. [0][3]				
R8756	NRSA63J-561X	MG RESISTOR	560Ω 1/16W J						
R8757	NRSA63J-561X	MG RESISTOR	560Ω 1/16W J		△ Symbol No.	Part No.	Part Name	Description	Local
R8758	NRSA63J-561X	MG RESISTOR	560Ω 1/16W J		IC430	SN74AHC04PW-X	IC		
R8760	NRSA63J-391X	MG RESISTOR	390Ω 1/16W J		IC501	TMP91CY22FG6AP3	IC		
R8761	NRSA63J-391X	MG RESISTOR	390Ω 1/16W J		IC502	BR24L01AFV-W-X	IC		
R8762	NRSA63J-391X	MG RESISTOR	390Ω 1/16W J		IC503	SN74AHCT126PW-X	IC(DIGITAL)		
R8764	NRSA63J-391X	MG RESISTOR	390Ω 1/16W J		IC504	NJU7241F33-X	IC		
R8765	NRSA63J-391X	MG RESISTOR	390Ω 1/16W J		IC601	TC94A15FG	IC		
R8766	NRSA63J-391X	MG RESISTOR	390Ω 1/16W J		IC651	NJU7772F15-X	IC		
R8768	NRSA63J-561X	MG RESISTOR	560Ω 1/16W J		IC652	TC94A34FG-002	IC		
R8769	NRSA63J-561X	MG RESISTOR	560Ω 1/16W J		IC653	MSM51V17405F5TS	IC		
R8770	NRSA63J-561X	MG RESISTOR	560Ω 1/16W J		IC654	SN74CBTLV3257PX	IC		
R8772	NRSA63J-391X	MG RESISTOR	390Ω 1/16W J		IC655	SN74AHC1G08V-X	IC		
R8773	NRSA63J-391X	MG RESISTOR	390Ω 1/16W J		IC681	LA6242H-X	IC		
R8774	NRSA63J-391X	MG RESISTOR	390Ω 1/16W J		Q430	2SB624/4/-X	TRANSISTOR		
R8776	NRSA63J-391X	MG RESISTOR	390Ω 1/16W J		Q431	UN2211-X	TRANSISTOR		
R8777	NRSA63J-391X	MG RESISTOR	390Ω 1/16W J		Q501	UN2111-X	TRANSISTOR		
R8778	NRSA63J-391X	MG RESISTOR	390Ω 1/16W J		Q502	UN2211-X	TRANSISTOR		
R8780	NRSA63J-561X	MG RESISTOR	560Ω 1/16W J		Q503	RPM-22PB	PHOTO TRANSISTOR		
R8781	NRSA63J-561X	MG RESISTOR	560Ω 1/16W J		Q504	UN2211-X	TRANSISTOR		
R8782	NRSA63J-561X	MG RESISTOR	560Ω 1/16W J		Q601	2SB1132/QR/-W	TRANSISTOR		
R8784	NRSA63J-391X	MG RESISTOR	390Ω 1/16W J		Q651	UN2211-X	TRANSISTOR		
R8785	NRSA63J-391X	MG RESISTOR	390Ω 1/16W J		Q652	2SB624/4/-X	TRANSISTOR		
R8786	NRSA63J-391X	MG RESISTOR	390Ω 1/16W J		Q681	2SB1184/QR/-X	TRANSISTOR		
R8801	NRSA63J-122X	MG RESISTOR	1.2kΩ 1/16W J		D506	1SS355-X	SI DIODE		
R8802	NRSA63J-122X	MG RESISTOR	1.2kΩ 1/16W J		D682	1SR154-400-X	DIODE		
R8803	NRSA63J-272X	MG RESISTOR	2.7kΩ 1/16W J		C431	NDC31HJ-270X	C CAPACITOR	27pF 50V J	
R8804	NRSA63J-272X	MG RESISTOR	2.7kΩ 1/16W J		C432	NDC31HJ-270X	C CAPACITOR	27pF 50V J	
R8805	NRSA63J-182X	MG RESISTOR	1.8kΩ 1/16W J		C433	NCB31CK-104X	C CAPACITOR	0.1uF 16V K	
R8806	NRSA63J-152X	MG RESISTOR	1.5kΩ 1/16W J		C501	NCB31HK-103X	C CAPACITOR	0.01uF 50V K	
R8811	NRSA63J-152X	MG RESISTOR	1.5kΩ 1/16W J	LHX55 1E,LH X551E U,LHX 551EX .LHX5 51EY	C502	NCB31HK-223X	C CAPACITOR	0.022uF 50V K	
R8811	NRSA63J-821X	MG RESISTOR	820Ω 1/16W J	LHX55 2E,LH X552E U,LHX 552EX .LHX5 52EY	C503	NEAD0GM-227X	E CAPACITOR	220uF 4V M	
R8812	NRSA63J-152X	MG RESISTOR	1.5kΩ 1/16W J	LHX55 1E,LH X551E U,LHX 551EX .LHX5 51EY	C504	NDC31HJ-220X	C CAPACITOR	22pF 50V J	
R8812	NRSA63J-821X	MG RESISTOR	820Ω 1/16W J	LHX55 2E,LH X552E U,LHX 552EX .LHX5 52EY	C505	NDC31HJ-220X	C CAPACITOR	22pF 50V J	
R8813	NRSA63J-102X	MG RESISTOR	1kΩ 1/16W J		C506	NCB31HK-103X	C CAPACITOR	0.01uF 50V K	
R8814	NRSA63J-152X	MG RESISTOR	1.5kΩ 1/16W J		C507	NCB31HK-223X	C CAPACITOR	0.022uF 50V K	
R8822	NRSA63J-271X	MG RESISTOR	270Ω 1/16W J		C508	NCB31HK-103X	C CAPACITOR	0.01uF 50V K	
R8825	NRSA63J-331X	MG RESISTOR	330Ω 1/16W J		C509	NCB31HK-223X	C CAPACITOR	0.022uF 50V K	
R8828	NRSA63J-271X	MG RESISTOR	270Ω 1/16W J		C510	NCB31HK-103X	C CAPACITOR	0.01uF 50V K	
R8831	NRSA63J-271X	MG RESISTOR	270Ω 1/16W J		C511	NCB31CK-104X	C CAPACITOR	0.1uF 16V K	
R8834	NRSA63J-331X	MG RESISTOR	330Ω 1/16W J		C512	NEAD0GM-227X	E CAPACITOR	220uF 4V M	
R8837	NRSA63J-271X	MG RESISTOR	270Ω 1/16W J		C513	NCB31HK-103X	C CAPACITOR	0.01uF 50V K	
L8301	NQL79GM-470X	COIL	47uH M		C514	NDC31HJ-102X	C CAPACITOR	1000pF 50V J	
CN801	NNZ0098-003X	CAR CONNECTOR			C516	NEAD0GM-227X	E CAPACITOR	220uF 4V M	
CN851	QGF0523F1-35W	CONNECTOR	FFC/FPC (1-35)		C530	NDC31HJ-102X	C CAPACITOR	1000pF 50V J	
CN871	QGF1041C1-06W	CONNECTOR	FFC/FPC (1-6)		C551	NCB31HK-103X	C CAPACITOR	0.01uF 50V K	
S8001	NSW0066-001X	TACT SW			C597	NDC31HJ-102X	C CAPACITOR	1000pF 50V J	
S8002	NSW0066-001X	TACT SW			C598	NDC31HJ-102X	C CAPACITOR	1000pF 50V J	
S8003	NSW0066-001X	TACT SW			C599	NDC31HJ-102X	C CAPACITOR	1000pF 50V J	
S8004	NSW0066-001X	TACT SW			C601	NEAF0JM-107X	E CAPACITOR	100uF 6.3V M	
S8005	NSW0066-001X	TACT SW			C602	NCB31HK-681X	C CAPACITOR	680pF 50V K	
S8006	NSW0218-001X	LUMISWITCH			C603	NEAF0JM-107X	E CAPACITOR	100uF 6.3V M	
S8007	NSW0066-001X	TACT SW			C604	NCB31HK-103X	C CAPACITOR	0.01uF 50V K	
S8201	NSW0066-001X	TACT SW			C605	NCB31CK-104X	C CAPACITOR	0.1uF 16V K	
					C606	NEAF0JM-476X	E CAPACITOR	47uF 6.3V M	
					C607	NCB31CK-104X	C CAPACITOR	0.1uF 16V K	
					C608	NCB31CK-104X	C CAPACITOR	0.1uF 16V K	
					C610	NCB31CK-104X	C CAPACITOR	0.1uF 16V K	
					C612	NCB31HK-103X	C CAPACITOR	0.01uF 50V K	
					C613	NCB31HK-103X	C CAPACITOR	0.01uF 50V K	
					C614	NCB31HK-103X	C CAPACITOR	0.01uF 50V K	
					C615	NCB31CK-224X	C CAPACITOR	0.22uF 16V K	

△ Symbol No.	Part No.	Part Name	Description	Local	△ Symbol No.	Part No.	Part Name	Description	Local
C616	NEAF0JM-476X	E CAPACITOR	47uF 6.3V M		R503	NRSA63J-102X	MG RESISTOR	1kΩ 1/16W J	
C617	NCB31CK-104X	C CAPACITOR	0.1uF 16V K		R504	NRSA63J-101X	MG RESISTOR	100Ω 1/16W J	
C618	NCB31CK-104X	C CAPACITOR	0.1uF 16V K		R505	NRSA63J-101X	MG RESISTOR	100Ω 1/16W J	
C621	NCB31CK-104X	C CAPACITOR	0.1uF 16V K		R506	NRSA63J-473X	MG RESISTOR	47kΩ 1/16W J	
C622	NEAF0JM-476X	E CAPACITOR	47uF 6.3V M		R507	NRSA63J-473X	MG RESISTOR	47kΩ 1/16W J	
C623	NCS31HJ-470X	C CAPACITOR	47pF 50V J		R508	NRSA63J-473X	MG RESISTOR	47kΩ 1/16W J	
C624	NCB31HK-153X	C CAPACITOR	0.015uF 50V K		R509	NRSA63J-473X	MG RESISTOR	47kΩ 1/16W J	
C625	NCB31HK-103X	C CAPACITOR	0.01uF 50V K		R510	NRSA63J-101X	MG RESISTOR	100Ω 1/16W J	
C626	NCB31HK-103X	C CAPACITOR	0.01uF 50V K		R511	NRSA63J-102X	MG RESISTOR	1kΩ 1/16W J	
C627	NCB31CK-104X	C CAPACITOR	0.1uF 16V K		R512	NRSA63J-473X	MG RESISTOR	47kΩ 1/16W J	
C629	NCB31EK-333X	C CAPACITOR	0.033uF 25V K		R513	NRSA63J-102X	MG RESISTOR	1kΩ 1/16W J	
C630	NCB31EK-333X	C CAPACITOR	0.033uF 25V K		R514	NRSA63J-473X	MG RESISTOR	47kΩ 1/16W J	
C631	NCS31HJ-471X	C CAPACITOR	470pF 50V J		R515	NRSA63J-473X	MG RESISTOR	47kΩ 1/16W J	
C632	NCS31HJ-471X	C CAPACITOR	470pF 50V J		R516	NRSA63J-102X	MG RESISTOR	1kΩ 1/16W J	
C633	NCB31CK-104X	C CAPACITOR	0.1uF 16V K		R517	NRSA63J-101X	MG RESISTOR	100Ω 1/16W J	
C634	NCB31HK-472X	C CAPACITOR	4700pF 50V K		R518	NRSA63J-101X	MG RESISTOR	100Ω 1/16W J	
C635	NCB31CK-153X	C CAPACITOR	0.015uF 16V K		R519	NRSA63J-101X	MG RESISTOR	100Ω 1/16W J	
C636	NCB31CK-473X	C CAPACITOR	0.047uF 16V K		R520	NRSA63J-101X	MG RESISTOR	100Ω 1/16W J	
C637	NCB31CK-473X	C CAPACITOR	0.047uF 16V K		R521	NRSA63J-101X	MG RESISTOR	100Ω 1/16W J	
C638	NCB31HK-103X	C CAPACITOR	0.01uF 50V K		R522	NRSA63J-101X	MG RESISTOR	100Ω 1/16W J	
C640	NCB31HK-103X	C CAPACITOR	0.01uF 50V K		R523	NRSA63J-101X	MG RESISTOR	100Ω 1/16W J	
C641	NEAF0JM-476X	E CAPACITOR	47uF 6.3V M		R524	NRSA63J-101X	MG RESISTOR	100Ω 1/16W J	
C642	NCS31HJ-101X	C CAPACITOR	100pF 50V J		R526	NRSA63J-473X	MG RESISTOR	47kΩ 1/16W J	
C643	NCB31CK-104X	C CAPACITOR	0.1uF 16V K		R527	NRSA63J-473X	MG RESISTOR	47kΩ 1/16W J	
C644	NCB31AK-334X	C CAPACITOR	0.33uF 10V K		R531	NRSA63J-473X	MG RESISTOR	47kΩ 1/16W J	
C645	NEAF0JM-476X	E CAPACITOR	47uF 6.3V M		R532	NRSA63J-473X	MG RESISTOR	47kΩ 1/16W J	
C646	NCB31CK-104X	C CAPACITOR	0.1uF 16V K		R533	NRSA63J-101X	MG RESISTOR	100Ω 1/16W J	
C647	NCS31HJ-680X	C CAPACITOR	68pF 50V J		R534	NRSA63J-101X	MG RESISTOR	100Ω 1/16W J	
C648	NBE20JM-106X	TA E CAPACITOR	10uF 6.3V M		R539	NRSA63J-473X	MG RESISTOR	47kΩ 1/16W J	
C649	NCB31HK-562X	C CAPACITOR	5600pF 50V K		R540	NRSA63J-473X	MG RESISTOR	47kΩ 1/16W J	
C651	NEAF0JM-476X	E CAPACITOR	47uF 6.3V M		R541	NRSA63J-101X	MG RESISTOR	100Ω 1/16W J	
C652	NCB31HK-103X	C CAPACITOR	0.01uF 50V K		R542	NRSA63J-103X	MG RESISTOR	10kΩ 1/16W J	
C653	NEAF0JM-476X	E CAPACITOR	47uF 6.3V M		R543	NRSA63J-101X	MG RESISTOR	100Ω 1/16W J	
C654	NCB31CK-104X	C CAPACITOR	0.1uF 16V K		R544	NRSA63J-101X	MG RESISTOR	100Ω 1/16W J	
C655	NCB31HK-103X	C CAPACITOR	0.01uF 50V K		R545	NRSA63J-103X	MG RESISTOR	10kΩ 1/16W J	
C656	NCB31CK-104X	C CAPACITOR	0.1uF 16V K		R546	NRSA63J-271X	MG RESISTOR	270Ω 1/16W J	
C658	NEAF0JM-476X	E CAPACITOR	47uF 6.3V M		R547	NRSA63J-271X	MG RESISTOR	270Ω 1/16W J	
C659	NCB31CK-104X	C CAPACITOR	0.1uF 16V K		R548	NRSA63D-822X	MG RESISTOR	8.2kΩ 1/16W D	
C660	NCS31HJ-101X	C CAPACITOR	100pF 50V J		R549	NRSA63J-472X	MG RESISTOR	4.7kΩ 1/16W J	
C661	NCB31HK-103X	C CAPACITOR	0.01uF 50V K		R550	NRSA63J-472X	MG RESISTOR	4.7kΩ 1/16W J	
C662	NCS31HJ-101X	C CAPACITOR	100pF 50V J		R551	NRSA63J-104X	MG RESISTOR	100kΩ 1/16W J	
C663	NCB31CK-104X	C CAPACITOR	0.1uF 16V K		R552	NRSA63J-104X	MG RESISTOR	100kΩ 1/16W J	
C664	NCB31HK-222X	C CAPACITOR	2200pF 50V K		R553	NRSA63J-183X	MG RESISTOR	18kΩ 1/16W J	
C665	NCB31CK-104X	C CAPACITOR	0.1uF 16V K		R554	NRSA63J-333X	MG RESISTOR	33kΩ 1/16W J	
C666	NCS31HJ-101X	C CAPACITOR	100pF 50V J		R555	NRSA63J-101X	MG RESISTOR	100Ω 1/16W J	
C668	NEAF0JM-476X	E CAPACITOR	47uF 6.3V M		R556	NRSA63J-0R0X	MG RESISTOR	0Ω 1/16W J	
C669	NCB31HK-103X	C CAPACITOR	0.01uF 50V K		R557	NRSA63J-104X	MG RESISTOR	100kΩ 1/16W J	
C670	NCB31CK-104X	C CAPACITOR	0.1uF 16V K		R558	NRSA63J-104X	MG RESISTOR	100kΩ 1/16W J	
C671	NBE21AM-106X	TA E CAPACITOR	10uF 10V M		R559	NRSA63J-0R0X	MG RESISTOR	0Ω 1/16W J	
C672	NCB31CK-104X	C CAPACITOR	0.1uF 16V K		R560	NRSA63J-101X	MG RESISTOR	100Ω 1/16W J	
C674	NCB31CK-104X	C CAPACITOR	0.1uF 16V K		R561	NRSA63J-104X	MG RESISTOR	100kΩ 1/16W J	
C675	NBE20JM-106X	TA E CAPACITOR	10uF 6.3V M		R562	NRSA63J-392X	MG RESISTOR	3.9kΩ 1/16W J	
C677	NDC31HJ-471X	C CAPACITOR	470pF 50V J		R563	NRSA63J-682X	MG RESISTOR	6.8kΩ 1/16W J	
C678	NDC31HJ-471X	C CAPACITOR	470pF 50V J		R564	NRSA63J-101X	MG RESISTOR	100Ω 1/16W J	
C680	NCB31CK-104X	C CAPACITOR	0.1uF 16V K		R565	NRSA63J-101X	MG RESISTOR	100Ω 1/16W J	
C682	NEAF1EM-475X	E CAPACITOR	4.7uF 25V M		R566	NRSA63J-101X	MG RESISTOR	100Ω 1/16W J	
C683	NCB31CK-104X	C CAPACITOR	0.1uF 16V K		R567	NRSA63J-473X	MG RESISTOR	47kΩ 1/16W J	
C684	NEAF1CM-476X	E CAPACITOR	47uF 16V M		R568	NRSA63J-102X	MG RESISTOR	1kΩ 1/16W J	
C685	NCB31CK-473X	C CAPACITOR	0.047uF 16V K		R569	NRSA63J-102X	MG RESISTOR	1kΩ 1/16W J	
C686	NCB31CK-473X	C CAPACITOR	0.047uF 16V K		R570	NRSA63J-102X	MG RESISTOR	1kΩ 1/16W J	
C687	NCB31CK-473X	C CAPACITOR	0.047uF 16V K		R571	NRSA63J-473X	MG RESISTOR	47kΩ 1/16W J	
C688	NCB31CK-473X	C CAPACITOR	0.047uF 16V K		R573	NRSA63J-332X	MG RESISTOR	3.3kΩ 1/16W J	
C689	NEAF1CM-476X	E CAPACITOR	47uF 16V M		R574	NRSA63J-332X	MG RESISTOR	3.3kΩ 1/16W J	
C690	NBE20JM-106X	TA E CAPACITOR	10uF 6.3V M		R575	NRSA63J-470X	MG RESISTOR	47Ω 1/16W J	
C693	NEAF1CM-476X	E CAPACITOR	47uF 16V M		R576	NRSA63J-470X	MG RESISTOR	47Ω 1/16W J	
C907	NEAF0JM-476X	E CAPACITOR	47uF 6.3V M		R577	NRSA63J-101X	MG RESISTOR	100Ω 1/16W J	
C908	NCB31CK-104X	C CAPACITOR	0.1uF 16V K		R578	NRSA63J-101X	MG RESISTOR	100Ω 1/16W J	
R431	NRSA63J-225X	MG RESISTOR	2.2MΩ 1/16W J		R579	NRSA63J-101X	MG RESISTOR	100Ω 1/16W J	
R432	NRSA63J-102X	MG RESISTOR	1kΩ 1/16W J		R580	NRSA63J-101X	MG RESISTOR	100Ω 1/16W J	
R434	NRSA63J-0R0X	MG RESISTOR	0Ω 1/16W J		R581	NRSA63J-101X	MG RESISTOR	100Ω 1/16W J	
R437	NRSA63J-102X	MG RESISTOR	1kΩ 1/16W J		R582	NRSA63J-101X	MG RESISTOR	100Ω 1/16W J	
R438	NRSA63J-102X	MG RESISTOR	1kΩ 1/16W J		R583	NRSA63J-101X	MG RESISTOR	100Ω 1/16W J	
R439	NRSA63J-101X	MG RESISTOR	100Ω 1/16W J		R584	NRSA63J-101X	MG RESISTOR	100Ω 1/16W J	
R440	NRSA63J-473X	MG RESISTOR	47kΩ 1/16W J		R585	NRSA63J-101X	MG RESISTOR	100Ω 1/16W J	
R441	NRSA63J-222X	MG RESISTOR	2.2kΩ 1/16W J		R586	NRSA63J-101X	MG RESISTOR	100Ω 1/16W J	
R501	NRSA63J-102X	MG RESISTOR	1kΩ 1/16W J		R587	NRSA63J-101X	MG RESISTOR	100Ω 1/16W J	
R502	NRSA63J-102X	MG RESISTOR	1kΩ 1/16W J		R588	NRSA63J-101X	MG RESISTOR	100Ω 1/16W J	
					R589	NRSA63J-101X	MG RESISTOR	100Ω 1/16W J	

△ Symbol No.	Part No.	Part Name	Description	Local	△ Symbol No.	Part No.	Part Name	Description	Local
R590	NRSA63J-101X	MG RESISTOR	100Ω 1/16W J		L621	NQL114K-470X	COIL	47uH K	
R591	NRSA63J-101X	MG RESISTOR	100Ω 1/16W J		L622	NQL114K-470X	COIL	47uH K	
R592	NRSA63J-473X	MG RESISTOR	47kΩ 1/16W J		L623	NQL114K-470X	COIL	47uH K	
R593	NRSA63J-0R0X	MG RESISTOR	0Ω 1/16W J		L624	NQL114K-470X	COIL	47uH K	
R594	NRSA63J-473X	MG RESISTOR	47kΩ 1/16W J		L651	NQL114K-470X	COIL	47uH K	
R599	NRSA63J-101X	MG RESISTOR	100Ω 1/16W J		L652	NQL114K-470X	COIL	47uH K	
R601	NRSA63J-0R0X	MG RESISTOR	0Ω 1/16W J		L653	NQL114K-470X	COIL	47uH K	
R602	NRSA63J-0R0X	MG RESISTOR	0Ω 1/16W J		L654	NQL114K-470X	COIL	47uH K	
R603	NRSA63D-183X	MG RESISTOR	18kΩ 1/16W D		L655	NQL114K-470X	COIL	47uH K	
R604	NRSA63D-183X	MG RESISTOR	18kΩ 1/16W D		L656	NQL114K-470X	COIL	47uH K	
R605	NRSA63J-220X	MG RESISTOR	22Ω 1/16W J		L901	NQL114K-470X	COIL	47uH K	
R606	NRSA63J-220X	MG RESISTOR	22Ω 1/16W J						
R609	NRSA63J-473X	MG RESISTOR	47kΩ 1/16W J		CN502	QGF0501F1-08X	CONNECTOR	FFC/FPC (1-8)	
R611	NRSA63J-473X	MG RESISTOR	47kΩ 1/16W J		CN503	QGB2027L5-20X	CONNECTOR	B-B (1-20)	
R612	NRSA63J-0R0X	MG RESISTOR	0Ω 1/16W J		CN601	QGF1006F2-15W	CONNECTOR	FFC/FPC (1-15)	
R613	NRSA63J-101X	MG RESISTOR	100Ω 1/16W J		CN602	QGF1038F1-05X	CONNECTOR	FFC/FPC (1-5)	
R614	NRSA63J-101X	MG RESISTOR	100Ω 1/16W J		CN901	NNZ0104-001X	SD CARD CONNE		
R615	NRSA63J-151X	MG RESISTOR	150Ω 1/16W J		SW4	NSW0219-001X	PUSH SWITCH		
R617	NRSA63J-473X	MG RESISTOR	47kΩ 1/16W J		SW5	NSW0219-001X	PUSH SWITCH		
R618	NRSA63J-101X	MG RESISTOR	100Ω 1/16W J		TH501	NAD0028-103X	N THERMISTOR	10kΩ	
R619	NRSA63J-101X	MG RESISTOR	100Ω 1/16W J		X430	NAX0375-001X	CRYSTAL	16.9344MHz	
R621	NRSA63J-470X	MG RESISTOR	47Ω 1/16W J		X501	NAX0385-001X	CRYSTAL	24.576MHz	
R622	NRSA63J-470X	MG RESISTOR	47Ω 1/16W J						
R623	NRSA63J-470X	MG RESISTOR	47Ω 1/16W J						
R624	NRSA63J-562X	MG RESISTOR	5.6kΩ 1/16W J						
R625	NRSA63J-473X	MG RESISTOR	47kΩ 1/16W J						
R626	NRSA63J-474X	MG RESISTOR	470kΩ 1/16W J						
R627	NRSA63J-183X	MG RESISTOR	18kΩ 1/16W J						
R628	NRSA63J-225X	MG RESISTOR	2.2MΩ 1/16W J						
R629	NRSA63J-223X	MG RESISTOR	22kΩ 1/16W J						
R630	NRSA63J-101X	MG RESISTOR	100Ω 1/16W J						
R631	NRSA63J-103X	MG RESISTOR	10kΩ 1/16W J						
R632	NRSA63J-473X	MG RESISTOR	47kΩ 1/16W J						
R635	NRSA63J-101X	MG RESISTOR	100Ω 1/16W J						
R636	NRSA63J-101X	MG RESISTOR	100Ω 1/16W J						
R637	NRSA63J-105X	MG RESISTOR	1MΩ 1/16W J						
R638	NRSA63J-472X	MG RESISTOR	4.7kΩ 1/16W J						
R639	NRSA63J-472X	MG RESISTOR	4.7kΩ 1/16W J						
R640	NRSA63J-472X	MG RESISTOR	4.7kΩ 1/16W J						
R641	NRSA63J-472X	MG RESISTOR	4.7kΩ 1/16W J						
R642	NRSA63J-103X	MG RESISTOR	10kΩ 1/16W J						
R643	NRSA63J-332X	MG RESISTOR	3.3kΩ 1/16W J						
R651	NRSA63J-104X	MG RESISTOR	100kΩ 1/16W J						
R653	NRSA63J-0R0X	MG RESISTOR	0Ω 1/16W J						
R655	NRSA63J-0R0X	MG RESISTOR	0Ω 1/16W J						
R656	NRSA63J-222X	MG RESISTOR	2.2kΩ 1/16W J						
R657	NRSA63J-473X	MG RESISTOR	47kΩ 1/16W J						
R658	NRSA63J-473X	MG RESISTOR	47kΩ 1/16W J						
R659	NRSA63J-101X	MG RESISTOR	100Ω 1/16W J						
R660	NRSA63J-101X	MG RESISTOR	100Ω 1/16W J						
R661	NRSA63J-101X	MG RESISTOR	100Ω 1/16W J						
R665	NRSA63J-101X	MG RESISTOR	100Ω 1/16W J						
R666	NRSA63J-101X	MG RESISTOR	100Ω 1/16W J						
R675	NRSA63J-221X	MG RESISTOR	220Ω 1/16W J						
R678	NRSA63J-101X	MG RESISTOR	100Ω 1/16W J						
R680	NRSA63J-243X	MG RESISTOR	24kΩ 1/16W J						
R681	NRSA63J-682X	MG RESISTOR	6.8kΩ 1/16W J						
R682	NRSA63J-822X	MG RESISTOR	8.2kΩ 1/16W J						
R683	NRSA63J-562X	MG RESISTOR	5.6kΩ 1/16W J						
R684	NRSA63J-0R0X	MG RESISTOR	0Ω 1/16W J						
R685	NRSA63J-0R0X	MG RESISTOR	0Ω 1/16W J						
R686	NRSA63J-0R0X	MG RESISTOR	0Ω 1/16W J						
R687	NRSA63J-223X	MG RESISTOR	22kΩ 1/16W J						
R688	NRSA63D-163X	MG RESISTOR	16kΩ 1/16W D						
R689	NRSA63D-103X	MG RESISTOR	10kΩ 1/16W D						
R901	NRSA63J-220X	MG RESISTOR	22Ω 1/16W J						
R902	NRSA63J-220X	MG RESISTOR	22Ω 1/16W J						
R903	NRSA63J-220X	MG RESISTOR	22Ω 1/16W J						
R904	NRSA63J-220X	MG RESISTOR	22Ω 1/16W J						
R905	NRSA63J-220X	MG RESISTOR	22Ω 1/16W J						
R906	NRSA63J-220X	MG RESISTOR	22Ω 1/16W J						
R907	NRSA63J-220X	MG RESISTOR	22Ω 1/16W J						
R908	NRSA63J-473X	MG RESISTOR	47kΩ 1/16W J						
R909	NRSA63J-473X	MG RESISTOR	47kΩ 1/16W J						
L432	NQL093K-1R8X	COIL	1.8uH K						
L501	NQL114K-470X	COIL	47uH K						
L502	NQL114K-470X	COIL	47uH K						

Main board (KD-LHX557)

Block No. [0][4]

Symbol No.	Part No.	Part Name	Description	Local
------------	----------	-----------	-------------	-------

IC10	SAF7730HV/N224A	IC		
IC11	PHK04P02T-X	POWER MOS FET		
IC171	NJM2160BV-X	IC		
IC191	NJM4565V-X	IC		
IC271	NJM2160BV-X	IC		
IC291	NJM4565V-X	IC		
IC361	NJM4580V-X	IC		
IC365	BD3805F-X	IC		
IC381	NJM4565V-X	IC		
IC382	NJM2160BV-X	IC		
IC401	MR27T1602F245TN	IC		
IC402	MSM6650G3-BK	IC		
IC701	MN101E01MDT	IC		
IC702	PST9121N-X	IC		
IC703	BR24L32F-W-X	IC		
IC710	SN74AHCT126PW-X	IC(DIGITAL)		
IC901	HA13164A	IC		
IC951	TB2901HQ	IC		
IC971	BD9781HFP-W	DC CONVERTOR		
IC973	BD3930FP-X	IC		
IC975	BA33BC0FP-X	IC		
IC991	BA6956AN	IC		
Q1	2SB624/4/-X	TRANSISTOR		
Q2	UN2211-X	TRANSISTOR		
Q30	UN2211-X	TRANSISTOR		
Q703	UN2213-X	DIGI TRANSISTOR		
Q901	UN2111-X	TRANSISTOR		
Q902	UN2211-X	TRANSISTOR		
Q903	2SB709A/QR/-X	TRANSISTOR		
Q907	UN2111-X	TRANSISTOR		
Q908	UN2211-X	TRANSISTOR		
Q941	UN2111-X	TRANSISTOR		
Q942	UN2113-X	DIGI TRANSISTOR		
Q951	2SD601A/QR/-X	TRANSISTOR		
Q952	UN2211-X	TRANSISTOR		
Q953	UN2213-X	DIGI TRANSISTOR		
Q954	UN2113-X	DIGI TRANSISTOR		
Q991	UN2211-X	TRANSISTOR		
Q1451	KTD1304-X	TRANSISTOR		
Q1452	KTD1304-X	TRANSISTOR		
Q2451	KTD1304-X	TRANSISTOR		
Q2452	KTD1304-X	TRANSISTOR		
Q3801	KTD1304-X	TRANSISTOR		
Q3802	UN2111-X	TRANSISTOR		
Q4002	2SD1781K/QR/-X	TRANSISTOR		
Q4003	2SD1781K/QR/-X	TRANSISTOR		
Q4101	2SD1383K/B/-X	TRANSISTOR		
Q4151	2SD1383K/B/-X	TRANSISTOR		
Q4201	2SD1383K/B/-X	TRANSISTOR		
Q4251	2SD1383K/B/-X	TRANSISTOR		
Q7201	UN2211-X	TRANSISTOR		
Q7202	UN2211-X	TRANSISTOR		
Q7503	UN2211-X	TRANSISTOR		
Q7504	2SB624/4/-X	TRANSISTOR		
Q9001	2SD601A/QR/-X	TRANSISTOR		
Q9051	UN2211-X	TRANSISTOR		
D701	MA111-X	SI DIODE		
D702	MA111-X	SI DIODE		
D703	MA111-X	SI DIODE		
D704	MA111-X	SI DIODE		
D705	MA8062/M/-X	Z DIODE		
D706	MA111-X	SI DIODE		
D718	SML-310LT/MN/-X	LED		
D719	SML-310LT/MN/-X	LED		
D720	SML-310LT/MN/-X	LED		
D901	1N5401-F64	DIODE		
D904	RB160M-30-X	SB DIODE		
D905	RB160M-30-X	SB DIODE		
D941	UDZS11B-X	Z DIODE		
D942	MA152WA-X	DIODE		
D943	MA152WA-X	DIODE		

Symbol No.	Part No.	Part Name	Description	Local
D944	UDZS3.3B-X	Z DIODE		
D945	MA111-X	SI DIODE		
D952	UDZS11B-X	Z DIODE		
D961	RB160M-30-X	SB DIODE		
D962	RB160M-30-X	SB DIODE		
D963	RB160M-30-X	SB DIODE		
D964	RB160M-30-X	SB DIODE		
D965	RB160M-30-X	SB DIODE		
D966	RB160M-30-X	SB DIODE		
D967	RB160M-30-X	SB DIODE		
D968	RB160M-30-X	SB DIODE		
D971	1SR154-400-X	DIODE		
D972	RB051L-40-X	SB DIODE		
D973	1SR154-400-X	DIODE		
D974	RB160M-30-X	SB DIODE		
D991	UDZS3.9B-X	Z DIODE		
D1451	MA152WA-X	DIODE		
D2451	MA152WA-X	DIODE		
D3901	UDZS4.7B-X	Z DIODE		
D3921	UDZS4.7B-X	Z DIODE		
D4001	MA111-X	SI DIODE		
D7501	SIR-34ST3F	SI DIODE		
D9051	MA152WA-X	DIODE		
C2	QERF1CM-476Z	E CAPACITOR	47uF 16V M	
C3	NCB31HK-391X	C CAPACITOR	390pF 50V K	
C4	QERF1CM-476Z	E CAPACITOR	47uF 16V M	
C5	NCB31HK-391X	C CAPACITOR	390pF 50V K	
C13	NCB31HK-391X	C CAPACITOR	390pF 50V K	
C30	NCB31CK-473X	C CAPACITOR	0.047uF 16V K	
C31	NCB31CK-473X	C CAPACITOR	0.047uF 16V K	
C32	NDC31HJ-100X	C CAPACITOR	10pF 50V J	
C33	NDC31HJ-100X	C CAPACITOR	10pF 50V J	
C34	QERF1EM-475Z	E CAPACITOR	4.7uF 25V M	
C35	NCB31CK-104X	C CAPACITOR	0.1uF 16V K	
C36	NCS31HJ-181X	C CAPACITOR	180pF 50V J	
C37	NCB31HK-103X	C CAPACITOR	0.01uF 50V K	
C38	NCB31HK-102X	C CAPACITOR	1000pF 50V K	
C39	NCB31HK-102X	C CAPACITOR	1000pF 50V K	
C40	NDC31HJ-101X	C CAPACITOR	100pF 50V J	
C41	NCB31CK-104X	C CAPACITOR	0.1uF 16V K	
C42	NCB31CK-104X	C CAPACITOR	0.1uF 16V K	
C43	NCB31CK-104X	C CAPACITOR	0.1uF 16V K	
C44	QERF1EM-475Z	E CAPACITOR	4.7uF 25V M	
C45	NBE20JM-475X	TA E CAPACITOR	4.7uF 6.3V M	
C46	NCB31CK-104X	C CAPACITOR	0.1uF 16V K	
C47	NBE20JM-475X	TA E CAPACITOR	4.7uF 6.3V M	
C48	NEA70JM-107X	E CAPACITOR	100uF 6.3V M	
C50	NBE20JM-226X	TA E CAPACITOR	22uF 6.3V M	
C51	NCB31CK-473X	C CAPACITOR	0.047uF 16V K	
C52	NCB31CK-473X	C CAPACITOR	0.047uF 16V K	
C53	NBE21CM-105X	TA E CAPACITOR	1uF 16V M	
C54	QERF0JM-476Z	E CAPACITOR	47uF 6.3V M	
C55	NCB31CK-104X	C CAPACITOR	0.1uF 16V K	
C56	NDC31HJ-101X	C CAPACITOR	100pF 50V J	
C57	NDC31HJ-101X	C CAPACITOR	100pF 50V J	
C58	NEA70GM-107X	E CAPACITOR	100uF 4V M	
C59	NCB31CK-333X	C CAPACITOR	0.033uF 16V K	
C60	NCB31CK-104X	C CAPACITOR	0.1uF 16V K	
C61	QERF0JM-107Z	E CAPACITOR	100uF 6.3V M	
C62	QERF0JM-227Z	E CAPACITOR	220uF 6.3V M	
C63	NCB31EK-223X	C CAPACITOR	0.022uF 25V K	
C64	NCB21CK-105X	C CAPACITOR	1uF 16V K	
C65	NCB31HK-471X	C CAPACITOR	470pF 50V K	
C66	NDC31HJ-101X	C CAPACITOR	100pF 50V J	
C67	NDC31HJ-101X	C CAPACITOR	100pF 50V J	
C68	NDC31HJ-101X	C CAPACITOR	100pF 50V J	
C69	NCB31CK-473X	C CAPACITOR	0.047uF 16V K	
C70	NDC31HJ-101X	C CAPACITOR	100pF 50V J	
C71	NDC31HJ-101X	C CAPACITOR	100pF 50V J	
C75	NCB31CK-473X	C CAPACITOR	0.047uF 16V K	
C76	NCB31EK-223X	C CAPACITOR	0.022uF 25V K	
C80	NCB31EK-223X	C CAPACITOR	0.022uF 25V K	
C81	NCB31CK-473X	C CAPACITOR	0.047uF 16V K	
C82	NCB31EK-223X	C CAPACITOR	0.022uF 25V K	
C102	NCB31HK-103X	C CAPACITOR	0.01uF 50V K	
C103	NCB31HK-103X	C CAPACITOR	0.01uF 50V K	

△ Symbol No.	Part No.	Part Name	Description	Local	△ Symbol No.	Part No.	Part Name	Description	Local
C104	NCB31HK-103X	C CAPACITOR	0.01uF 50V K		C1601	NDC31HJ-101X	C CAPACITOR	100pF 50V J	
C701	NDC31HJ-7R0X	C CAPACITOR	7pF 50V J		C1602	NCB31HK-821X	C CAPACITOR	820pF 50V K	
C702	NDC31HJ-7R0X	C CAPACITOR	7pF 50V J		C1603	QTE1H55-225Z	E CAPACITOR	2.2uF 50V	
C703	NDC31HJ-330X	C CAPACITOR	33pF 50V J		C1604	NCS31HJ-121X	C CAPACITOR	120pF 50V J	
C704	NDC31HJ-180X	C CAPACITOR	18pF 50V J		C1605	QERF1EM-475Z	E CAPACITOR	4.7uF 25V M	
C705	QERF1CM-107Z	E CAPACITOR	100uF 16V M		C1606	QERF0JM-476Z	E CAPACITOR	47uF 6.3V M	
C707	NDC31HJ-101X	C CAPACITOR	100pF 50V J		C1651	QTE1H55-225Z	E CAPACITOR	2.2uF 50V	
C708	NBE21AM-106X	TA E CAPACITOR	10uF 10V M		C1701	QERF1EM-475Z	E CAPACITOR	4.7uF 25V M	
C709	NCB31HK-103X	C CAPACITOR	0.01uF 50V K		C1702	NCB31CK-104X	C CAPACITOR	0.1uF 16V K	
C710	NCB31CK-473X	C CAPACITOR	0.047uF 16V K		C1703	QERF1AM-107Z	E CAPACITOR	100uF 10V M	
C712	NCB31HK-103X	C CAPACITOR	0.01uF 50V K		C1704	NCB31HK-152X	C CAPACITOR	1500pF 50V K	
C713	QERF0JM-337Z	E CAPACITOR	330uF 6.3V M		C1705	NEA71HM-225X	E CAPACITOR	2.2uF 50V M	
C714	NCB31HK-103X	C CAPACITOR	0.01uF 50V K		C1721	QERF1EM-475Z	E CAPACITOR	4.7uF 25V M	
C715	NCB31CK-104X	C CAPACITOR	0.1uF 16V K		C1722	NCB31CK-104X	C CAPACITOR	0.1uF 16V K	
C716	NCB31HK-471X	C CAPACITOR	470pF 50V K		C1723	QERF1AM-107Z	E CAPACITOR	100uF 10V M	
C717	NCB31HK-103X	C CAPACITOR	0.01uF 50V K		C1724	NCB31HK-152X	C CAPACITOR	1500pF 50V K	
C719	QERF0JM-337Z	E CAPACITOR	330uF 6.3V M		C1725	NEA71HM-225X	E CAPACITOR	2.2uF 50V M	
C720	NCB31HK-103X	C CAPACITOR	0.01uF 50V K		C1751	NFV81CM-105X	MF CAPACITOR	1uF 16V M	
C721	NDC31HJ-101X	C CAPACITOR	100pF 50V J		C1752	NDC31HJ-101X	C CAPACITOR	100pF 50V J	
C776	NBE20JM-476X	TA E CAPACITOR	47uF 6.3V M		C1771	NFV81CM-105X	MF CAPACITOR	1uF 16V M	
C777	NCB31HK-103X	C CAPACITOR	0.01uF 50V K		C1772	NDC31HJ-101X	C CAPACITOR	100pF 50V J	
C901	QEZ0723-338	E CAPACITOR	3300uF		C1801	NCB31CK-104X	C CAPACITOR	0.1uF 16V K	
C902	NEA71CM-226X	E CAPACITOR	22uF 16V M		C1901	QERF1EM-475Z	E CAPACITOR	4.7uF 25V M	
C903	NEA71CM-226X	E CAPACITOR	22uF 16V M		C1902	NCB21CK-105X	C CAPACITOR	1uF 16V K	
C904	NCB31HK-103X	C CAPACITOR	0.01uF 50V K		C1921	QERF1EM-475Z	E CAPACITOR	4.7uF 25V M	
C905	QERF1AM-107Z	E CAPACITOR	100uF 10V M		C1922	NCB21CK-105X	C CAPACITOR	1uF 16V K	
C906	NCB31CK-104X	C CAPACITOR	0.1uF 16V K		C2401	QERF1HM-225Z	E CAPACITOR	2.2uF 50V M	
C907	NCB31HK-103X	C CAPACITOR	0.01uF 50V K		C2402	NCB31HK-472X	C CAPACITOR	4700pF 50V K	
C908	QERF1AM-227Z	E CAPACITOR	220uF 10V M		C2403	NDC31HJ-101X	C CAPACITOR	100pF 50V J	
C909	NBP21CM-106X	TA E CAPACITOR	10uF 16V M		C2404	NCB31HK-102X	C CAPACITOR	1000pF 50V K	
C910	NBP21CM-106X	TA E CAPACITOR	10uF 16V M		C2451	NDC31HJ-101X	C CAPACITOR	100pF 50V J	
C911	NCB31CK-104X	C CAPACITOR	0.1uF 16V K		C2452	NDC31HJ-101X	C CAPACITOR	100pF 50V J	
C912	NEA71HM-225X	E CAPACITOR	2.2uF 50V M		C2501	NDC31HJ-101X	C CAPACITOR	100pF 50V J	
C941	QERF1CM-107Z	E CAPACITOR	100uF 16V M		C2502	NCB30JK-105X	C CAPACITOR	1uF 6.3V K	
C942	QERF1CM-476Z	E CAPACITOR	47uF 16V M		C2552	NCB31HK-332X	C CAPACITOR	3300pF 50V K	
C943	QERF0JM-107Z	E CAPACITOR	100uF 6.3V M		C2601	NDC31HJ-101X	C CAPACITOR	100pF 50V J	
C944	NBE20JM-106X	TA E CAPACITOR	10uF 6.3V M		C2602	NCB31HK-821X	C CAPACITOR	820pF 50V K	
C950	QERF1CM-476Z	E CAPACITOR	47uF 16V M		C2603	QTE1H55-225Z	E CAPACITOR	2.2uF 50V	
C951	QERF1CM-226Z	E CAPACITOR	22uF 16V M		C2604	NCS31HJ-121X	C CAPACITOR	120pF 50V J	
C952	NCB31HK-103X	C CAPACITOR	0.01uF 50V K		C2605	QERF1EM-475Z	E CAPACITOR	4.7uF 25V M	
C953	QERF1CM-106Z	E CAPACITOR	10uF 16V M		C2606	QERF0JM-476Z	E CAPACITOR	47uF 6.3V M	
C954	QERF1EM-475Z	E CAPACITOR	4.7uF 25V M		C2651	QTE1H55-225Z	E CAPACITOR	2.2uF 50V	
C955	QERF1HM-225Z	E CAPACITOR	2.2uF 50V M		C2701	QERF1EM-475Z	E CAPACITOR	4.7uF 25V M	
C971	NCB31CK-104X	C CAPACITOR	0.1uF 16V K		C2702	NCB31CK-104X	C CAPACITOR	0.1uF 16V K	
C972	QERF1CM-107Z	E CAPACITOR	100uF 16V M		C2703	QERF1AM-107Z	E CAPACITOR	100uF 10V M	
C973	NCB31CK-104X	C CAPACITOR	0.1uF 16V K		C2704	NCB31HK-152X	C CAPACITOR	1500pF 50V K	
C974	NCB31HK-104X	C CAPACITOR	0.1uF 50V K		C2705	NEA71HM-225X	E CAPACITOR	2.2uF 50V M	
C975	NCB31HK-472X	C CAPACITOR	4700pF 50V K		C2721	QERF1EM-475Z	E CAPACITOR	4.7uF 25V M	
C983	QERF1CM-107Z	E CAPACITOR	100uF 16V M		C2722	NCB31CK-104X	C CAPACITOR	0.1uF 16V K	
C984	NCB31HK-103X	C CAPACITOR	0.01uF 50V K		C2723	QERF1AM-107Z	E CAPACITOR	100uF 10V M	
C985	QERF0JM-337Z	E CAPACITOR	330uF 6.3V M		C2724	NCB31HK-152X	C CAPACITOR	1500pF 50V K	
C987	QEXL1AM-476Z	E CAPACITOR	47uF 10V M		C2725	NEA71HM-225X	E CAPACITOR	2.2uF 50V M	
C988	NCB31HK-103X	C CAPACITOR	0.01uF 50V K		C2751	NFV81CM-105X	MF CAPACITOR	1uF 16V M	
C989	QERF0JM-107Z	E CAPACITOR	100uF 6.3V M		C2752	NDC31HJ-101X	C CAPACITOR	100pF 50V J	
C991	QERF1AM-107Z	E CAPACITOR	100uF 10V M		C2757	NFV81CM-105X	MF CAPACITOR	1uF 16V M	
C992	NCB31CK-473X	C CAPACITOR	0.047uF 16V K		C2772	NDC31HJ-101X	C CAPACITOR	100pF 50V J	
C1001	NCB31HK-103X	C CAPACITOR	0.01uF 50V K		C2801	NCB31CK-224X	C CAPACITOR	0.22uF 16V K	
C1003	NBE20JM-106X	TA E CAPACITOR	10uF 6.3V M		C2901	QERF1EM-475Z	E CAPACITOR	4.7uF 25V M	
C1004	NBE20JM-106X	TA E CAPACITOR	10uF 6.3V M		C2902	NCB21CK-105X	C CAPACITOR	1uF 16V K	
C1005	NBE20JM-476X	TA E CAPACITOR	47uF 6.3V M		C2921	QERF1EM-475Z	E CAPACITOR	4.7uF 25V M	
C1006	NCB31CK-104X	C CAPACITOR	0.1uF 16V K		C2922	NCB21CK-105X	C CAPACITOR	1uF 16V K	
C1007	NCB31CK-104X	C CAPACITOR	0.1uF 16V K		C3401	NEA71CM-476X	E CAPACITOR	47uF 16V M	
C1008	NBE20JM-476X	TA E CAPACITOR	47uF 6.3V M		C3402	NCB31CK-473X	C CAPACITOR	0.047uF 16V K	
C1009	NCB31CK-473X	C CAPACITOR	0.047uF 16V K		C3403	NCB31CK-473X	C CAPACITOR	0.047uF 16V K	
C1010	NCB31CK-473X	C CAPACITOR	0.047uF 16V K		C3451	NCB31CK-473X	C CAPACITOR	0.047uF 16V K	
C1011	NBE20JM-106X	TA E CAPACITOR	10uF 6.3V M		C3452	NCB31HK-102X	C CAPACITOR	1000pF 50V K	
C1012	NCB31CK-473X	C CAPACITOR	0.047uF 16V K		C3501	NCB31CK-473X	C CAPACITOR	0.047uF 16V K	
C1013	NCB31CK-473X	C CAPACITOR	0.047uF 16V K		C3601	QERF1CM-476Z	E CAPACITOR	47uF 16V M	
C1401	QERF1HM-225Z	E CAPACITOR	2.2uF 50V M		C3651	QERF1CM-106Z	E CAPACITOR	10uF 16V M	
C1402	NCB31HK-472X	C CAPACITOR	4700pF 50V K		C3652	NCB31CK-104X	C CAPACITOR	0.1uF 16V K	
C1403	NDC31HJ-101X	C CAPACITOR	100pF 50V J		C3653	NBE21AM-106X	TA E CAPACITOR	10uF 10V M	
C1404	NCB31HK-102X	C CAPACITOR	1000pF 50V K		C3701	NBE20JM-226X	TA E CAPACITOR	22uF 6.3V M	
C1451	NDC31HJ-101X	C CAPACITOR	100pF 50V J		C3702	QERF1AM-476Z	E CAPACITOR	47uF 10V M	
C1452	NDC31HJ-101X	C CAPACITOR	100pF 50V J		C3721	NBE20JM-226X	TA E CAPACITOR	22uF 6.3V M	
C1501	NDC31HJ-101X	C CAPACITOR	100pF 50V J		C3722	QERF1AM-476Z	E CAPACITOR	47uF 10V M	
C1502	NCB30JK-105X	C CAPACITOR	1uF 6.3V K		C3801	NCB31HK-332X	C CAPACITOR	3300pF 50V K	
C1552	NCB31HK-332X	C CAPACITOR	3300pF 50V K		C3802	NEA71HM-105X	E CAPACITOR	1uF 50V M	

△ Symbol No.	Part No.	Part Name	Description	Local	△ Symbol No.	Part No.	Part Name	Description	Local
C3803	NCB31HK-104X	C CAPACITOR	0.1uF 50V K		R707	NRSA63J-221X	MG RESISTOR	220Ω 1/16W J	
C3804	NEA71HM-225X	E CAPACITOR	2.2uF 50V M		R708	NRSA63J-273X	MG RESISTOR	27kΩ 1/16W J	
C3805	NBE20JM-476X	TA E CAPACITOR	47uF 6.3V M		R711	NRSA63J-563X	MG RESISTOR	56kΩ 1/16W J	
C3806	NCB31HK-822X	C CAPACITOR	8200pF 50V K		R715	NRSA63J-102X	MG RESISTOR	1kΩ 1/16W J	
C3807	NCB31CK-473X	C CAPACITOR	0.047uF 16V K		R716	NRSA63J-102X	MG RESISTOR	1kΩ 1/16W J	
C3808	NCB31HK-152X	C CAPACITOR	1500pF 50V K		R717	NRSA63J-102X	MG RESISTOR	1kΩ 1/16W J	
C3809	NBE20JM-226X	TA E CAPACITOR	22uF 6.3V M		R718	NRSA63J-0R0X	MG RESISTOR	0Ω 1/16W J	
C3810	QERF1AM-107Z	E CAPACITOR	100uF 10V M		R720	NRSA63J-102X	MG RESISTOR	1kΩ 1/16W J	
C3811	NEA71HM-225X	E CAPACITOR	2.2uF 50V M		R721	NRSA63J-102X	MG RESISTOR	1kΩ 1/16W J	
C3901	QERF1AM-476Z	E CAPACITOR	47uF 10V M		R722	NRSA63J-101X	MG RESISTOR	100Ω 1/16W J	
C3902	QERF0JM-476Z	E CAPACITOR	47uF 6.3V M		R723	NRSA63J-101X	MG RESISTOR	100Ω 1/16W J	
C3922	QERF0JM-476Z	E CAPACITOR	47uF 6.3V M		R724	NRSA63J-101X	MG RESISTOR	100Ω 1/16W J	
C4001	QERF0JM-107Z	E CAPACITOR	100uF 6.3V M		R725	NRSA63J-103X	MG RESISTOR	10kΩ 1/16W J	
C4002	NCB31EK-273X	C CAPACITOR	0.027uF 25V K		R726	NRSA63J-104X	MG RESISTOR	100kΩ 1/16W J	
C4004	NDC31HJ-390X	C CAPACITOR	39pF 50V J		R729	NRSA63J-102X	MG RESISTOR	1kΩ 1/16W J	
C4005	NDC31HJ-390X	C CAPACITOR	39pF 50V J		R730	NRSA63J-102X	MG RESISTOR	1kΩ 1/16W J	
C4006	NCB31CK-473X	C CAPACITOR	0.047uF 16V K		R731	NRSA63J-0R0X	MG RESISTOR	0Ω 1/16W J	
C4007	NCB31CK-473X	C CAPACITOR	0.047uF 16V K		R732	NRSA63J-0R0X	MG RESISTOR	0Ω 1/16W J	
C4008	NEA71CM-476X	E CAPACITOR	47uF 16V M		R733	NRSA63J-102X	MG RESISTOR	1kΩ 1/16W J	
C4009	NCB31HK-102X	C CAPACITOR	1000pF 50V K		R734	NRSA63J-271X	MG RESISTOR	270Ω 1/16W J	
C4010	NBE20JM-106X	TA E CAPACITOR	10uF 6.3V M		R735	NRSA63J-103X	MG RESISTOR	10kΩ 1/16W J	
C4011	NCB31HK-103X	C CAPACITOR	0.01uF 50V K		R736	NRSA63J-271X	MG RESISTOR	270Ω 1/16W J	
C4012	NBE20JM-106X	TA E CAPACITOR	10uF 6.3V M		R737	NRSA63J-102X	MG RESISTOR	1kΩ 1/16W J	
C4101	NCB31CK-104X	C CAPACITOR	0.1uF 16V K		R738	NRSA63J-102X	MG RESISTOR	1kΩ 1/16W J	
C4102	NCB31HK-392X	C CAPACITOR	3900pF 50V K		R739	NRSA63J-104X	MG RESISTOR	100kΩ 1/16W J	
C4151	NCB31CK-104X	C CAPACITOR	0.1uF 16V K		R741	NRSA63J-102X	MG RESISTOR	1kΩ 1/16W J	
C4152	NCB31HK-392X	C CAPACITOR	3900pF 50V K		R742	NRSA63J-102X	MG RESISTOR	1kΩ 1/16W J	
C4201	NCB31CK-104X	C CAPACITOR	0.1uF 16V K		R743	NRSA63J-102X	MG RESISTOR	1kΩ 1/16W J	
C4202	NCB31HK-392X	C CAPACITOR	3900pF 50V K		R744	NRSA63J-102X	MG RESISTOR	1kΩ 1/16W J	
C4251	NCB31CK-104X	C CAPACITOR	0.1uF 16V K		R745	NRSA63J-102X	MG RESISTOR	1kΩ 1/16W J	
C4252	NCB31HK-392X	C CAPACITOR	3900pF 50V K		R746	NRSA63J-102X	MG RESISTOR	1kΩ 1/16W J	
C7001	QERF0JM-337Z	E CAPACITOR	330uF 6.3V M		R747	NRSA63J-473X	MG RESISTOR	47kΩ 1/16W J	
C7002	QERF0JM-337Z	E CAPACITOR	330uF 6.3V M		R749	NRSA63J-102X	MG RESISTOR	1kΩ 1/16W J	
C7003	NCB31HK-103X	C CAPACITOR	0.01uF 50V K		R750	NRSA63J-102X	MG RESISTOR	1kΩ 1/16W J	
C7101	NCB31HK-103X	C CAPACITOR	0.01uF 50V K		R751	NRSA63J-123X	MG RESISTOR	12kΩ 1/16W J	
C7201	NCB31HK-103X	C CAPACITOR	0.01uF 50V K		R752	NRSA63J-102X	MG RESISTOR	1kΩ 1/16W J	
C7202	NCB31HK-103X	C CAPACITOR	0.01uF 50V K		R754	NRSA63J-223X	MG RESISTOR	22kΩ 1/16W J	
C7203	NCB31HK-103X	C CAPACITOR	0.01uF 50V K		R755	NRSA63J-221X	MG RESISTOR	220Ω 1/16W J	
C7204	NCB31HK-103X	C CAPACITOR	0.01uF 50V K		R756	NRSA63J-221X	MG RESISTOR	220Ω 1/16W J	
C9001	QERF1CM-106Z	E CAPACITOR	10uF 16V M		R757	NRSA63J-102X	MG RESISTOR	1kΩ 1/16W J	
C9051	NCB31CK-104X	C CAPACITOR	0.1uF 16V K		R758	NRSA63J-473X	MG RESISTOR	47kΩ 1/16W J	
R2	NRSA63J-101X	MG RESISTOR	100Ω 1/16W J		R759	NRSA63J-102X	MG RESISTOR	1kΩ 1/16W J	
R3	NRSA63J-0R0X	MG RESISTOR	0Ω 1/16W J		R760	NRSA63J-102X	MG RESISTOR	1kΩ 1/16W J	
R4	NRSA63J-0R0X	MG RESISTOR	0Ω 1/16W J		R761	NRSA63J-0R0X	MG RESISTOR	0Ω 1/16W J	
R7	NRSA63J-101X	MG RESISTOR	100Ω 1/16W J		R762	NRSA63J-102X	MG RESISTOR	1kΩ 1/16W J	
R8	NRSA63J-101X	MG RESISTOR	100Ω 1/16W J		R763	NRSA63J-102X	MG RESISTOR	1kΩ 1/16W J	
R9	NRSA63J-273X	MG RESISTOR	27kΩ 1/16W J		R764	NRSA63J-102X	MG RESISTOR	1kΩ 1/16W J	
R10	NRSA63J-273X	MG RESISTOR	27kΩ 1/16W J		R765	NRSA63J-102X	MG RESISTOR	1kΩ 1/16W J	
R11	NRS181J-100X	MG RESISTOR	10Ω 1/8W J		R766	NRSA63J-102X	MG RESISTOR	1kΩ 1/16W J	
R12	NRSA63J-103X	MG RESISTOR	10kΩ 1/16W J		R767	NRSA63J-102X	MG RESISTOR	1kΩ 1/16W J	
R13	NRSA63J-102X	MG RESISTOR	1kΩ 1/16W J		R768	NRSA63J-224X	MG RESISTOR	220kΩ 1/16W J	
R40	NRSA63J-101X	MG RESISTOR	100Ω 1/16W J		R769	NRSA63J-224X	MG RESISTOR	220kΩ 1/16W J	
R41	NRSA63J-100X	MG RESISTOR	10Ω 1/16W J		R770	NRSA63J-224X	MG RESISTOR	220kΩ 1/16W J	
R42	NRSA63J-222X	MG RESISTOR	2.2kΩ 1/16W J		R771	NRSA63J-561X	MG RESISTOR	560Ω 1/16W J	
R43	NRSA63J-222X	MG RESISTOR	2.2kΩ 1/16W J		R772	NRSA63J-561X	MG RESISTOR	560Ω 1/16W J	
R44	NRSA63J-0R0X	MG RESISTOR	0Ω 1/16W J		R774	NRSA63J-473X	MG RESISTOR	47kΩ 1/16W J	
R45	NRSA02J-0R0X	MG RESISTOR	0Ω 1/10W J		R775	NRSA63J-222X	MG RESISTOR	2.2kΩ 1/16W J	
R46	NRS181J-0R0X	MG RESISTOR	0Ω 1/8W J		R776	NRSA63J-222X	MG RESISTOR	2.2kΩ 1/16W J	
R49	NRSA63J-103X	MG RESISTOR	10kΩ 1/16W J		R777	NRSA63J-473X	MG RESISTOR	47kΩ 1/16W J	
R60	NRSA02J-100X	MG RESISTOR	10Ω 1/10W J		R784	NRSA63J-102X	MG RESISTOR	1kΩ 1/16W J	
R63	NRSA63J-101X	MG RESISTOR	100Ω 1/16W J		R788	NRSA63J-473X	MG RESISTOR	47kΩ 1/16W J	
R64	NRSA63J-101X	MG RESISTOR	100Ω 1/16W J		R789	NRSA63J-473X	MG RESISTOR	47kΩ 1/16W J	
R65	NRSA63J-101X	MG RESISTOR	100Ω 1/16W J		R790	NRSA63J-473X	MG RESISTOR	47kΩ 1/16W J	
R66	NRSA63J-101X	MG RESISTOR	100Ω 1/16W J		R794	NRSA63J-473X	MG RESISTOR	47kΩ 1/16W J	
R67	NRSA63J-101X	MG RESISTOR	100Ω 1/16W J		R796	NRSA63J-0R0X	MG RESISTOR	0Ω 1/16W J	
R68	NRSA63J-101X	MG RESISTOR	100Ω 1/16W J		R901	NRSA63J-912X	MG RESISTOR	9.1kΩ 1/16W J	
R69	NRSA63J-101X	MG RESISTOR	100Ω 1/16W J		R902	NRSA63J-472X	MG RESISTOR	4.7kΩ 1/16W J	
R70	NRSA63J-101X	MG RESISTOR	100Ω 1/16W J		R903	NRSA63J-562X	MG RESISTOR	5.6kΩ 1/16W J	
R71	NRSA63J-101X	MG RESISTOR	100Ω 1/16W J		R904	NRSA63J-102X	MG RESISTOR	1kΩ 1/16W J	
R78	NRSA63J-101X	MG RESISTOR	100Ω 1/16W J		R905	NRSA63J-103X	MG RESISTOR	10kΩ 1/16W J	
R701	NRSA63J-181X	MG RESISTOR	180Ω 1/16W J		R908	NRSA63J-153X	MG RESISTOR	15kΩ 1/16W J	
R702	NRSA63J-473X	MG RESISTOR	47kΩ 1/16W J		R909	NRSA63J-473X	MG RESISTOR	47kΩ 1/16W J	
R703	NRSA63J-106X	MG RESISTOR	10MΩ 1/16W J		R910	QRE142J-102X	C RESISTOR	1kΩ 1/4W J	
R704	NRSA63J-473X	MG RESISTOR	47kΩ 1/16W J		R912	NRS181J-222X	MG RESISTOR	2.2kΩ 1/8W J	
R705	NRSA63J-221X	MG RESISTOR	220Ω 1/16W J		R913	NRSA63J-102X	MG RESISTOR	1kΩ 1/16W J	
R706	NRSA63J-102X	MG RESISTOR	1kΩ 1/16W J		R918	NRSA63J-473X	MG RESISTOR	47kΩ 1/16W J	
					R941	NRSA02J-101X	MG RESISTOR	100Ω 1/10W J	

△ Symbol No.	Part No.	Part Name	Description	Local	△ Symbol No.	Part No.	Part Name	Description	Local
R951	NRSA63J-222X	MG RESISTOR	2.2kΩ 1/16W J		R2702	NRSA63J-243X	MG RESISTOR	24kΩ 1/16W J	
R952	NRSA63J-273X	MG RESISTOR	27kΩ 1/16W J		R2703	NRSA63J-473X	MG RESISTOR	47kΩ 1/16W J	
R953	NRSA63J-103X	MG RESISTOR	10kΩ 1/16W J		R2704	NRSA63J-363X	MG RESISTOR	36kΩ 1/16W J	
R954	NRSA63J-0R0X	MG RESISTOR	0Ω 1/16W J		R2705	NRSA63J-102X	MG RESISTOR	1kΩ 1/16W J	
R955	NRSA63J-473X	MG RESISTOR	47kΩ 1/16W J		R2706	NRSA63J-104X	MG RESISTOR	100kΩ 1/16W J	
R956	NRSA63J-473X	MG RESISTOR	47kΩ 1/16W J		R2722	NRSA63J-243X	MG RESISTOR	24kΩ 1/16W J	
R971	NRSA63J-394X	MG RESISTOR	390kΩ 1/16W J		R2723	NRSA63J-473X	MG RESISTOR	47kΩ 1/16W J	
R972	NRSA63J-154X	MG RESISTOR	150kΩ 1/16W J		R2724	NRSA63J-363X	MG RESISTOR	36kΩ 1/16W J	
R973	NRSA63D-563X	MG RESISTOR	56kΩ 1/16W D		R2725	NRSA63J-102X	MG RESISTOR	1kΩ 1/16W J	
R974	NRSA63D-394X	MG RESISTOR	390kΩ 1/16W D		R2726	NRSA63J-104X	MG RESISTOR	100kΩ 1/16W J	
R975	NRSA63D-103X	MG RESISTOR	10kΩ 1/16W D		R2754	NRSA63J-102X	MG RESISTOR	1kΩ 1/16W J	
R976	NRSA63J-103X	MG RESISTOR	10kΩ 1/16W J		R2774	NRSA63J-102X	MG RESISTOR	1kΩ 1/16W J	
R978	NRS181J-220X	MG RESISTOR	22Ω 1/8W J		R2801	NRSA63J-101X	MG RESISTOR	100Ω 1/16W J	
R979	NRS181J-220X	MG RESISTOR	22Ω 1/8W J		R2901	NRSA63D-103X	MG RESISTOR	10kΩ 1/16W D	
R991	NRSA63J-102X	MG RESISTOR	1kΩ 1/16W J		R2902	NRSA63D-103X	MG RESISTOR	10kΩ 1/16W D	
R1009	NRSA02J-0R0X	MG RESISTOR	0Ω 1/10W J		R2903	NRSA63J-154X	MG RESISTOR	150kΩ 1/16W J	
R1401	NRSA63J-682X	MG RESISTOR	6.8kΩ 1/16W J		R2904	NRSA63J-103X	MG RESISTOR	10kΩ 1/16W J	
R1402	NRSA63J-473X	MG RESISTOR	47kΩ 1/16W J		R2905	NRSA63J-103X	MG RESISTOR	10kΩ 1/16W J	
R1404	NRSA63J-123X	MG RESISTOR	12kΩ 1/16W J		R2921	NRSA63D-103X	MG RESISTOR	10kΩ 1/16W D	
R1451	NRSA63J-821X	MG RESISTOR	820Ω 1/16W J		R2922	NRSA63D-103X	MG RESISTOR	10kΩ 1/16W D	
R1452	NRSA63J-821X	MG RESISTOR	820Ω 1/16W J		R2923	NRSA63J-154X	MG RESISTOR	150kΩ 1/16W J	
R1453	NRSA63J-181X	MG RESISTOR	180Ω 1/16W J		R2924	NRSA63J-103X	MG RESISTOR	10kΩ 1/16W J	
R1454	NRSA63J-181X	MG RESISTOR	180Ω 1/16W J		R2925	NRSA63J-103X	MG RESISTOR	10kΩ 1/16W J	
R1455	NRSA63J-222X	MG RESISTOR	2.2kΩ 1/16W J		R3401	NRSA63J-473X	MG RESISTOR	47kΩ 1/16W J	
R1456	NRSA63J-222X	MG RESISTOR	2.2kΩ 1/16W J		R3403	NRSA63J-471X	MG RESISTOR	470Ω 1/16W J	
R1501	NRSA63J-101X	MG RESISTOR	100Ω 1/16W J		R3405	NRSA63J-100X	MG RESISTOR	10Ω 1/16W J	
R1502	NRSA63J-104X	MG RESISTOR	100kΩ 1/16W J		R3653	NRSA63J-472X	MG RESISTOR	4.7kΩ 1/16W J	
R1503	NRSA63J-682X	MG RESISTOR	6.8kΩ 1/16W J		R3654	NRSA63J-103X	MG RESISTOR	10kΩ 1/16W J	
R1504	NRSA63J-103X	MG RESISTOR	10kΩ 1/16W J		R3655	NRSA63J-393X	MG RESISTOR	39kΩ 1/16W J	
R1601	NRSA63J-203X	MG RESISTOR	20kΩ 1/16W J		R3801	NRSA63J-104X	MG RESISTOR	100kΩ 1/16W J	
R1602	NRSA63J-333X	MG RESISTOR	33kΩ 1/16W J		R3802	NRSA63J-822X	MG RESISTOR	8.2kΩ 1/16W J	
R1603	NRSA63J-123X	MG RESISTOR	12kΩ 1/16W J		R3803	NRSA63J-273X	MG RESISTOR	27kΩ 1/16W J	
R1604	NRSA63J-473X	MG RESISTOR	47kΩ 1/16W J		R3804	NRSA63J-473X	MG RESISTOR	47kΩ 1/16W J	
R1605	NRSA63J-103X	MG RESISTOR	10kΩ 1/16W J		R3805	NRSA63J-821X	MG RESISTOR	820Ω 1/16W J	
R1606	NRSA63J-103X	MG RESISTOR	10kΩ 1/16W J		R3806	NRSA63J-363X	MG RESISTOR	36kΩ 1/16W J	
R1702	NRSA63J-243X	MG RESISTOR	24kΩ 1/16W J		R3807	NRSA63J-222X	MG RESISTOR	2.2kΩ 1/16W J	
R1703	NRSA63J-473X	MG RESISTOR	47kΩ 1/16W J		R3808	NRSA63J-103X	MG RESISTOR	10kΩ 1/16W J	
R1704	NRSA63J-363X	MG RESISTOR	36kΩ 1/16W J		R3809	NRSA63J-103X	MG RESISTOR	10kΩ 1/16W J	
R1705	NRSA63J-102X	MG RESISTOR	1kΩ 1/16W J		R3810	NRSA63J-0R0X	MG RESISTOR	0Ω 1/16W J	
R1706	NRSA63J-104X	MG RESISTOR	100kΩ 1/16W J		R3811	NRSA63J-243X	MG RESISTOR	24kΩ 1/16W J	
R1722	NRSA63J-243X	MG RESISTOR	24kΩ 1/16W J		R3901	NRSA63J-100X	MG RESISTOR	10Ω 1/16W J	
R1723	NRSA63J-473X	MG RESISTOR	47kΩ 1/16W J		R3902	NRSA63J-471X	MG RESISTOR	470Ω 1/16W J	
R1724	NRSA63J-363X	MG RESISTOR	36kΩ 1/16W J		R3922	NRSA63J-471X	MG RESISTOR	470Ω 1/16W J	
R1725	NRSA63J-102X	MG RESISTOR	1kΩ 1/16W J		R4013	NRSA63J-102X	MG RESISTOR	1kΩ 1/16W J	
R1726	NRSA63J-104X	MG RESISTOR	100kΩ 1/16W J		R4014	NRSA63J-102X	MG RESISTOR	1kΩ 1/16W J	
R1754	NRSA63J-102X	MG RESISTOR	1kΩ 1/16W J		R4015	NRSA63J-563X	MG RESISTOR	56kΩ 1/16W J	
R1774	NRSA63J-102X	MG RESISTOR	1kΩ 1/16W J		R4017	NRSA63J-102X	MG RESISTOR	1kΩ 1/16W J	
R1801	NRSA63J-101X	MG RESISTOR	100Ω 1/16W J		R4021	NRSA63J-104X	MG RESISTOR	100kΩ 1/16W J	
R1901	NRSA63D-103X	MG RESISTOR	10kΩ 1/16W D		R4023	NRSA63J-102X	MG RESISTOR	1kΩ 1/16W J	
R1902	NRSA63D-103X	MG RESISTOR	10kΩ 1/16W D		R4031	NRSA63J-102X	MG RESISTOR	1kΩ 1/16W J	
R1903	NRSA63J-154X	MG RESISTOR	150kΩ 1/16W J		R4032	NRSA63J-102X	MG RESISTOR	1kΩ 1/16W J	
R1904	NRSA63J-103X	MG RESISTOR	10kΩ 1/16W J		R4033	NRSA63J-102X	MG RESISTOR	1kΩ 1/16W J	
R1905	NRSA63J-103X	MG RESISTOR	10kΩ 1/16W J		R4034	NRSA63J-102X	MG RESISTOR	1kΩ 1/16W J	
R1921	NRSA63D-103X	MG RESISTOR	10kΩ 1/16W D		R4035	NRSA63J-473X	MG RESISTOR	47kΩ 1/16W J	
R1922	NRSA63D-103X	MG RESISTOR	10kΩ 1/16W D		R4036	NRSA63J-102X	MG RESISTOR	1kΩ 1/16W J	
R1923	NRSA63J-154X	MG RESISTOR	150kΩ 1/16W J		R4037	NRSA63J-102X	MG RESISTOR	1kΩ 1/16W J	
R1924	NRSA63J-103X	MG RESISTOR	10kΩ 1/16W J		R4038	NRSA63J-102X	MG RESISTOR	1kΩ 1/16W J	
R1925	NRSA63J-103X	MG RESISTOR	10kΩ 1/16W J		R4039	NRSA63J-102X	MG RESISTOR	1kΩ 1/16W J	
R2401	NRSA63J-682X	MG RESISTOR	6.8kΩ 1/16W J		R4040	NRSA63J-102X	MG RESISTOR	1kΩ 1/16W J	
R2402	NRSA63J-473X	MG RESISTOR	47kΩ 1/16W J		R4041	NRSA63J-102X	MG RESISTOR	1kΩ 1/16W J	
R2404	NRSA63J-123X	MG RESISTOR	12kΩ 1/16W J		R4042	NRSA63J-102X	MG RESISTOR	1kΩ 1/16W J	
R2451	NRSA63J-821X	MG RESISTOR	820Ω 1/16W J		R4043	NRSA63J-102X	MG RESISTOR	1kΩ 1/16W J	
R2452	NRSA63J-821X	MG RESISTOR	820Ω 1/16W J		R4067	NRSA63J-0R0X	MG RESISTOR	0Ω 1/16W J	
R2453	NRSA63J-181X	MG RESISTOR	180Ω 1/16W J		R4069	NRSA63J-562X	MG RESISTOR	5.6kΩ 1/16W J	
R2454	NRSA63J-181X	MG RESISTOR	180Ω 1/16W J		R4070	NRSA63J-222X	MG RESISTOR	2.2kΩ 1/16W J	
R2455	NRSA63J-222X	MG RESISTOR	2.2kΩ 1/16W J		R4071	NRSA63J-104X	MG RESISTOR	100kΩ 1/16W J	
R2456	NRSA63J-222X	MG RESISTOR	2.2kΩ 1/16W J		R4073	NRSA63J-222X	MG RESISTOR	2.2kΩ 1/16W J	
R2501	NRSA63J-101X	MG RESISTOR	100Ω 1/16W J		R4100	NRSA02J-102X	MG RESISTOR	1kΩ 1/10W J	
R2502	NRSA63J-104X	MG RESISTOR	100kΩ 1/16W J		R4101	NRSA63J-473X	MG RESISTOR	47kΩ 1/16W J	
R2503	NRSA63J-682X	MG RESISTOR	6.8kΩ 1/16W J		R4102	NRSA63J-224X	MG RESISTOR	220kΩ 1/16W J	
R2504	NRSA63J-103X	MG RESISTOR	10kΩ 1/16W J		R4103	NRSA63J-272X	MG RESISTOR	2.7kΩ 1/16W J	
R2601	NRSA63J-203X	MG RESISTOR	20kΩ 1/16W J		R4151	NRSA63J-473X	MG RESISTOR	47kΩ 1/16W J	
R2602	NRSA63J-333X	MG RESISTOR	33kΩ 1/16W J		R4152	NRSA63J-224X	MG RESISTOR	220kΩ 1/16W J	
R2603	NRSA63J-123X	MG RESISTOR	12kΩ 1/16W J		R4153	NRSA63J-272X	MG RESISTOR	2.7kΩ 1/16W J	
R2604	NRSA63J-473X	MG RESISTOR	47kΩ 1/16W J		R4201	NRSA63J-473X	MG RESISTOR	47kΩ 1/16W J	
R2605	NRSA63J-103X	MG RESISTOR	10kΩ 1/16W J		R4202	NRSA63J-224X	MG RESISTOR	220kΩ 1/16W J	
R2606	NRSA63J-103X	MG RESISTOR	10kΩ 1/16W J		R4203	NRSA63J-272X	MG RESISTOR	2.7kΩ 1/16W J	

△ Symbol No.	Part No.	Part Name	Description	Local	△ Symbol No.	Part No.	Part Name	Description	Local
R4251	NRSA63J-473X	MG RESISTOR	47kΩ 1/16W J		Q8002	2SB709A/QR/-X	TRANSISTOR		
R4252	NRSA63J-224X	MG RESISTOR	220kΩ 1/16W J		Q8301	2SD601A/QR/-X	TRANSISTOR		
R4253	NRSA63J-272X	MG RESISTOR	2.7kΩ 1/16W J		Q8701	2SB709A/QR/-X	TRANSISTOR		
R7002	NRSA63J-473X	MG RESISTOR	47kΩ 1/16W J		Q8702	2SB709A/QR/-X	TRANSISTOR		
R7101	NRSA63J-333X	MG RESISTOR	33kΩ 1/16W J		Q8703	2SD601A/QR/-X	TRANSISTOR		
R7102	NRSA63J-183X	MG RESISTOR	18kΩ 1/16W J		Q8704	2SD601A/QR/-X	TRANSISTOR		
R7103	NRSA63J-0R0X	MG RESISTOR	0Ω 1/16W J		Q8705	UN2111-X	TRANSISTOR		
R7104	NRSA63J-102X	MG RESISTOR	1kΩ 1/16W J		Q8751	2SD601A/QR/-X	TRANSISTOR		
R7105	NRSA63J-104X	MG RESISTOR	100kΩ 1/16W J		Q8752	2SD601A/QR/-X	TRANSISTOR		
R7106	NRSA63J-104X	MG RESISTOR	100kΩ 1/16W J		Q8753	2SD601A/QR/-X	TRANSISTOR		
R7107	NRSA63J-101X	MG RESISTOR	100Ω 1/16W J		Q8754	2SD601A/QR/-X	TRANSISTOR		
R7110	NRSA63J-101X	MG RESISTOR	100Ω 1/16W J		Q8755	2SD601A/QR/-X	TRANSISTOR		
R7111	NRSA63J-104X	MG RESISTOR	100kΩ 1/16W J		Q8756	2SD601A/QR/-X	TRANSISTOR		
R7112	NRSA63J-392X	MG RESISTOR	3.9kΩ 1/16W J		Q8757	2SD601A/QR/-X	TRANSISTOR		
R7113	NRSA63J-102X	MG RESISTOR	1kΩ 1/16W J		Q8758	2SD601A/QR/-X	TRANSISTOR		
R7116	NRSA63J-104X	MG RESISTOR	100kΩ 1/16W J		Q8759	2SD601A/QR/-X	TRANSISTOR		
R7117	NRSA63J-104X	MG RESISTOR	100kΩ 1/16W J		Q8760	2SD601A/QR/-X	TRANSISTOR		
R7118	NRSA63J-682X	MG RESISTOR	6.8kΩ 1/16W J		Q8761	2SD601A/QR/-X	TRANSISTOR		
R7119	NRSA63J-102X	MG RESISTOR	1kΩ 1/16W J		Q8762	2SD601A/QR/-X	TRANSISTOR		
R7120	NRSA02J-100X	MG RESISTOR	10Ω 1/10W J		Q8763	2SD601A/QR/-X	TRANSISTOR		
R7205	NRSA63J-0R0X	MG RESISTOR	0Ω 1/16W J		Q8764	2SD601A/QR/-X	TRANSISTOR		
R7501	NRS181J-181X	MG RESISTOR	180Ω 1/8W J		Q8765	2SD601A/QR/-X	TRANSISTOR		
R7504	NRSA63J-473X	MG RESISTOR	47kΩ 1/16W J		Q8766	2SD601A/QR/-X	TRANSISTOR		
R7505	NRSA63J-222X	MG RESISTOR	2.2kΩ 1/16W J		Q8767	2SD601A/QR/-X	TRANSISTOR		
R9001	NRSA63J-104X	MG RESISTOR	100kΩ 1/16W J		Q8768	2SD601A/QR/-X	TRANSISTOR		
R9002	NRSA63J-103X	MG RESISTOR	10kΩ 1/16W J		Q8770	2SD601A/QR/-X	TRANSISTOR		
R9003	NRSA63J-473X	MG RESISTOR	47kΩ 1/16W J		Q8771	2SD601A/QR/-X	TRANSISTOR		
R9051	NRSA63J-473X	MG RESISTOR	47kΩ 1/16W J		Q8772	2SD601A/QR/-X	TRANSISTOR		
R9052	NRSA63J-102X	MG RESISTOR	1kΩ 1/16W J		Q8773	2SD601A/QR/-X	TRANSISTOR		
L1	NQL334J-4R7X	COIL	4.7uH J		Q8774	2SD601A/QR/-X	TRANSISTOR		
L30	NQR0129-003X	FERRITE BESDA			Q8775	2SD601A/QR/-X	TRANSISTOR		
L31	NQL093K-2R2X	COIL	2.2uH K		Q8776	2SD601A/QR/-X	TRANSISTOR		
L40	NQR0129-003X	FERRITE BESDA			Q8777	2SD601A/QR/-X	TRANSISTOR		
L63	NQL093K-1R8X	COIL	1.8uH K		Q8778	2SD601A/QR/-X	TRANSISTOR		
L701	NQL79GM-470X	COIL	47uH M		Q8779	2SD601A/QR/-X	TRANSISTOR		
L702	NQL79GM-470X	COIL	47uH M		Q8780	2SD601A/QR/-X	TRANSISTOR		
L901	QQR1640-001	CHOKE COIL			Q8781	2SD601A/QR/-X	TRANSISTOR		
L971	NQLB7GM-100X	COIL	10uH M		D8001	MA152WK-X	SI DIODE		
L972	NQL71EM-330X	COIL	33uH M		D8002	UDZS6.2B-X	Z DIODE		
L4001	NQL79GM-470X	COIL	47uH M		D8003	UDZS6.2B-X	Z DIODE		
L7201	NQL79GM-470X	COIL	47uH M		D8004	UDZS6.2B-X	Z DIODE		
CN341	QGA2006C1-04	CONNECTOR	W-B (1-4)		D8005	UDZS6.2B-X	Z DIODE		
CN345	QNN0490-001	PIN JACK			D8006	UDZS6.2B-X	Z DIODE		
CN351	QNZ0095-001	CONNECTOR			D8007	UDZS6.2B-X	Z DIODE		
CN381	QGA2501C1-03	CONNECTOR	W-B (1-3)		D8008	UDZS6.2B-X	Z DIODE		
CN701	QGF1041C3-16W	CONNECTOR	FFC/FPC (1-16)		D8009	UDZS6.2B-X	Z DIODE		
CN702	QGA2006F1-02	CONNECTOR	W-B (1-2)		D8010	UDZS6.2B-X	Z DIODE		
CN721	QGB2027M5-20S	CONNECTOR	B-B (1-20)		D8201	MA111-X	SI DIODE		
CN901	QNZ0611-001	16P CONNECTOR			D8203	MA152WA-X	DIODE		
CN991	QGA2501F1-02	CONNECTOR	W-B (1-2)		D8701	UDZS6.2B-X	Z DIODE		
CN992	QJB005-040909	SIN ID C-B WIRE			D8702	UDZS6.2B-X	Z DIODE		
J1	QAM0556-001	ANT CABLE			D8703	UDZS6.2B-X	Z DIODE		
PP2	QZW0010-001	STYLE PIN			D8704	UDZS6.2B-X	Z DIODE		
TU1	QAU0324-002	TUNER PUCK			D8731	NSCM315C/Z/-W	LED		
X1	QAX0781-001Z	CRYSTAL	41.600MHz		D8732	NSCM315C/Z/-W	LED		
X701	QAX0782-001Z	CRYSTAL	32.000MHz		D8733	NSCM315C/Z/-W	LED		
X702	QAX0401-001	CRYSTAL	32.768KHz		D8734	NSCM315C/Z/-W	LED		
X4001	QAX0763-001Z	C RESONATOR	4.19MHz		D8735	NSCM315C/Z/-W	LED		
					D8751	UDZS6.2B-X	Z DIODE		
					D8752	UDZS6.2B-X	Z DIODE		
					D8753	UDZS6.2B-X	Z DIODE		
					D8754	UDZS6.2B-X	Z DIODE		
					D8755	UDZS6.2B-X	Z DIODE		
					D8756	UDZS6.2B-X	Z DIODE		
					D8757	UDZS6.2B-X	Z DIODE		
					D8758	UDZS6.2B-X	Z DIODE		
					D8759	UDZS6.2B-X	Z DIODE		
					D8760	UDZS6.2B-X	Z DIODE		
					D8761	UDZS6.2B-X	Z DIODE		
					D8762	UDZS6.2B-X	Z DIODE		
					D8763	UDZS6.2B-X	Z DIODE		
					D8764	UDZS6.2B-X	Z DIODE		
					D8765	UDZS6.2B-X	Z DIODE		
					D8801	MA152WK-X	SI DIODE		
					D8802	SML-310LT/MN/-X	LED		
					D8803	SML-310LT/MN/-X	LED		
					D8809	SML-310LT/MN/-X	LED		

Switch board (KD-LHX557)

Block No. [0][5]

△ Symbol No.	Part No.	Part Name	Description	Local
IC801	MN102H60KDR	IC		
IC815	SG32M90TFIR3C01	IC		
IC821	IC-PST3424U-X	IC		
IC831	NJU7241F33-X	IC		
IC841	RPM7338-V4	RM.RECEIVER		
Q8001	2SB709A/QR/-X	TRANSISTOR		

△ Symbol No.	Part No.	Part Name	Description	Local	△ Symbol No.	Part No.	Part Name	Description	Local
D8810	SML-310LT/MN/-X	LED			R8023	NRSA63J-331X	MG RESISTOR	330Ω 1/16W J	
C8002	NBE20JM-106X	TA E CAPACITOR	10uF 6.3V M		R8024	NRSA63J-331X	MG RESISTOR	330Ω 1/16W J	
C8003	NCB31CK-473X	C CAPACITOR	0.047uF 16V K		R8025	NRSA63J-331X	MG RESISTOR	330Ω 1/16W J	
C8006	NCB31HK-471X	C CAPACITOR	470pF 50V K		R8026	NRSA63J-680X	MG RESISTOR	68Ω 1/16W J	
C8008	NCB31CK-473X	C CAPACITOR	0.047uF 16V K		R8027	NRSA63J-473X	MG RESISTOR	47kΩ 1/16W J	
C8009	NBE20JM-475X	TA E CAPACITOR	4.7uF 6.3V M		R8028	NRSA63J-331X	MG RESISTOR	330Ω 1/16W J	
C8010	NBE20JM-475X	TA E CAPACITOR	4.7uF 6.3V M		R8029	NRSA63J-331X	MG RESISTOR	330Ω 1/16W J	
C8011	NBE20JM-475X	TA E CAPACITOR	4.7uF 6.3V M		R8030	NRSA63J-331X	MG RESISTOR	330Ω 1/16W J	
C8013	NCB31CK-473X	C CAPACITOR	0.047uF 16V K		R8031	NRSA63J-331X	MG RESISTOR	330Ω 1/16W J	
C8014	NDC31HJ-7R0X	C CAPACITOR	7pF 50V J		R8032	NRSA63J-331X	MG RESISTOR	330Ω 1/16W J	
C8015	NDC31HJ-7R0X	C CAPACITOR	7pF 50V J		R8033	NRSA63J-331X	MG RESISTOR	330Ω 1/16W J	
C8151	NBE20JM-106X	TA E CAPACITOR	10uF 6.3V M		R8034	NRSA63J-331X	MG RESISTOR	330Ω 1/16W J	
C8152	NCB31CK-473X	C CAPACITOR	0.047uF 16V K		R8035	NRSA63J-331X	MG RESISTOR	330Ω 1/16W J	
C8153	NCB31HK-471X	C CAPACITOR	470pF 50V K		R8036	NRSA63J-331X	MG RESISTOR	330Ω 1/16W J	
C8201	NBE20JM-475X	TA E CAPACITOR	4.7uF 6.3V M		R8037	NRSA63J-331X	MG RESISTOR	330Ω 1/16W J	
C8202	NCB31CK-473X	C CAPACITOR	0.047uF 16V K		R8038	NRSA63J-331X	MG RESISTOR	330Ω 1/16W J	
C8301	NBE20JM-106X	TA E CAPACITOR	10uF 6.3V M		R8039	NRSA63J-331X	MG RESISTOR	330Ω 1/16W J	
C8302	NCB31CK-473X	C CAPACITOR	0.047uF 16V K		R8040	NRSA63J-331X	MG RESISTOR	330Ω 1/16W J	
C8303	NBE20JM-106X	TA E CAPACITOR	10uF 6.3V M		R8041	NRSA63J-331X	MG RESISTOR	330Ω 1/16W J	
C8304	NBE21AM-106X	TA E CAPACITOR	10uF 10V M		R8042	NRSA63J-331X	MG RESISTOR	330Ω 1/16W J	
C8401	NBE21AM-475X	TA E CAPACITOR	4.7uF 10V M		R8043	NRSA63J-331X	MG RESISTOR	330Ω 1/16W J	
C8502	NCB21CK-105X	C CAPACITOR	1uF 16V K		R8044	NRSA63J-822X	MG RESISTOR	8.2kΩ 1/16W J	
C8503	NCB31CK-473X	C CAPACITOR	0.047uF 16V K		R8045	NRSA63J-331X	MG RESISTOR	330Ω 1/16W J	
C8504	NCB21CK-105X	C CAPACITOR	1uF 16V K		R8046	NRSA63J-331X	MG RESISTOR	330Ω 1/16W J	
C8505	NCJ31CK-105X-A	C CAPACITOR			R8047	NRSA63J-331X	MG RESISTOR	330Ω 1/16W J	
C8506	NCJ31CK-105X-A	C CAPACITOR			R8048	NRSA63J-331X	MG RESISTOR	330Ω 1/16W J	
C8507	NCB11EM-105X	C CAPACITOR	1uF 25V M		R8049	NRSA63J-331X	MG RESISTOR	330Ω 1/16W J	
C8508	NCJ31CK-105X-A	C CAPACITOR			R8050	NRSA63J-104X	MG RESISTOR	100kΩ 1/16W J	
C8509	NCB11EM-105X	C CAPACITOR	1uF 25V M		R8051	NRSA63J-104X	MG RESISTOR	100kΩ 1/16W J	
C8510	NCJ31CK-105X-A	C CAPACITOR			R8053	NRSA63J-331X	MG RESISTOR	330Ω 1/16W J	
C8511	NCJ31CK-105X-A	C CAPACITOR			R8054	NRSA63J-104X	MG RESISTOR	100kΩ 1/16W J	
C8512	NCJ31CK-105X-A	C CAPACITOR			R8055	NRSA63J-103X	MG RESISTOR	10kΩ 1/16W J	
C8513	NCJ31CK-105X-A	C CAPACITOR			R8056	NRSA63J-103X	MG RESISTOR	10kΩ 1/16W J	
C8514	NCJ31CK-105X-A	C CAPACITOR			R8059	NRSA63J-102X	MG RESISTOR	1kΩ 1/16W J	
C8515	NCB31CK-473X	C CAPACITOR	0.047uF 16V K		R8060	NRSA63J-102X	MG RESISTOR	1kΩ 1/16W J	
C8516	NBE20JM-475X	TA E CAPACITOR	4.7uF 6.3V M		R8061	NRSA63J-102X	MG RESISTOR	1kΩ 1/16W J	
C8517	NCB11EM-105X	C CAPACITOR	1uF 25V M		R8062	NRSA63J-102X	MG RESISTOR	1kΩ 1/16W J	
C8518	NCJ31CK-105X-A	C CAPACITOR			R8063	NRSA63J-102X	MG RESISTOR	1kΩ 1/16W J	
C8519	NCJ31CK-105X-A	C CAPACITOR			R8064	NRSA63J-152X	MG RESISTOR	1.5kΩ 1/16W J	
C8520	NCJ31CK-105X-A	C CAPACITOR			R8065	NRSA63J-152X	MG RESISTOR	1.5kΩ 1/16W J	
C8521	NCJ31CK-105X-A	C CAPACITOR			R8066	NRSA63J-473X	MG RESISTOR	47kΩ 1/16W J	
C8522	NCJ31CK-105X-A	C CAPACITOR			R8067	NRSA63J-473X	MG RESISTOR	47kΩ 1/16W J	
C8701	NCB31HK-472X	C CAPACITOR	4700pF 50V K		R8069	NRSA63J-331X	MG RESISTOR	330Ω 1/16W J	
C8702	NCB31HK-472X	C CAPACITOR	4700pF 50V K		R8070	NRSA63J-473X	MG RESISTOR	47kΩ 1/16W J	
C8703	NCB31HK-821X	C CAPACITOR	820pF 50V K		R8071	NRSA63J-222X	MG RESISTOR	2.2kΩ 1/16W J	
C8704	NCB31HK-821X	C CAPACITOR	820pF 50V K		R8072	NRSA63J-331X	MG RESISTOR	330Ω 1/16W J	
C8731	NCB31CK-473X	C CAPACITOR	0.047uF 16V K		R8073	NRSA63J-331X	MG RESISTOR	330Ω 1/16W J	
C8732	NCB31CK-473X	C CAPACITOR	0.047uF 16V K		R8074	NRSA63J-331X	MG RESISTOR	330Ω 1/16W J	
C8733	NCB31CK-473X	C CAPACITOR	0.047uF 16V K		R8075	NRSA63J-331X	MG RESISTOR	330Ω 1/16W J	
C8734	NCB31CK-473X	C CAPACITOR	0.047uF 16V K		R8076	NRSA63J-331X	MG RESISTOR	330Ω 1/16W J	
C8735	NCB31CK-473X	C CAPACITOR	0.047uF 16V K		R8077	NRSA63J-331X	MG RESISTOR	330Ω 1/16W J	
C8736	NCB31CK-473X	C CAPACITOR	0.047uF 16V K		R8078	NRSA63J-331X	MG RESISTOR	330Ω 1/16W J	
C8737	NCB31CK-473X	C CAPACITOR	0.047uF 16V K		R8079	NRSA63J-331X	MG RESISTOR	330Ω 1/16W J	
C8738	NCB31CK-473X	C CAPACITOR	0.047uF 16V K		R8082	NRSA63J-331X	MG RESISTOR	330Ω 1/16W J	
C8739	NCB31CK-473X	C CAPACITOR	0.047uF 16V K		R8083	NRSA63J-331X	MG RESISTOR	330Ω 1/16W J	
C8740	NCB31CK-473X	C CAPACITOR	0.047uF 16V K		R8084	NRSA63J-331X	MG RESISTOR	330Ω 1/16W J	
C8741	NCB31CK-473X	C CAPACITOR	0.047uF 16V K		R8085	NRSA63J-331X	MG RESISTOR	330Ω 1/16W J	
C8742	NCB31CK-473X	C CAPACITOR	0.047uF 16V K		R8086	NRSA63J-331X	MG RESISTOR	330Ω 1/16W J	
C8743	NCB31CK-473X	C CAPACITOR	0.047uF 16V K		R8087	NRSA63J-331X	MG RESISTOR	330Ω 1/16W J	
C8744	NCB31CK-473X	C CAPACITOR	0.047uF 16V K		R8088	NRSA63J-331X	MG RESISTOR	330Ω 1/16W J	
C8745	NCB31CK-473X	C CAPACITOR	0.047uF 16V K		R8095	NRS181J-0R0X	MG RESISTOR	0Ω 1/8W J	
R8001	NRSA63J-301X	MG RESISTOR	300Ω 1/16W J		R8097	NRSA63J-0R0X	MG RESISTOR	0Ω 1/16W J	
R8002	NRSA63J-271X	MG RESISTOR	270Ω 1/16W J		R8098	NRSA63J-0R0X	MG RESISTOR	0Ω 1/16W J	
R8003	NRSA63J-391X	MG RESISTOR	390Ω 1/16W J		R8152	NRS181J-0R0X	MG RESISTOR	0Ω 1/8W J	
R8004	NRSA63J-301X	MG RESISTOR	300Ω 1/16W J		R8153	NRSA63J-0R0X	MG RESISTOR	0Ω 1/16W J	
R8005	NRSA63J-271X	MG RESISTOR	270Ω 1/16W J		R8201	NRSA63J-222X	MG RESISTOR	2.2kΩ 1/16W J	
R8006	NRSA63J-103X	MG RESISTOR	10kΩ 1/16W J		R8202	NRSA63J-473X	MG RESISTOR	47kΩ 1/16W J	
R8007	NRSA63J-474X	MG RESISTOR	470kΩ 1/16W J		R8203	NRSA63J-102X	MG RESISTOR	1kΩ 1/16W J	
R8008	NRSA63J-473X	MG RESISTOR	47kΩ 1/16W J		R8301	NRSA63J-104X	MG RESISTOR	100kΩ 1/16W J	
R8009	NRSA63J-473X	MG RESISTOR	47kΩ 1/16W J		R8302	NRSA63J-474X	MG RESISTOR	470kΩ 1/16W J	
R8011	NRSA63J-331X	MG RESISTOR	330Ω 1/16W J		R8401	NRSA63J-470X	MG RESISTOR	47Ω 1/16W J	
R8012	NRSA63J-331X	MG RESISTOR	330Ω 1/16W J		R8402	NRSA63J-0R0X	MG RESISTOR	0Ω 1/16W J	
R8013	NRSA63J-331X	MG RESISTOR	330Ω 1/16W J		R8501	NRSA63J-0R0X	MG RESISTOR	0Ω 1/16W J	
R8016	NRSA63J-331X	MG RESISTOR	330Ω 1/16W J		R8705	NRSA63J-332X	MG RESISTOR	3.3kΩ 1/16W J	
R8021	NRSA63J-331X	MG RESISTOR	330Ω 1/16W J		R8708	NRSA63J-332X	MG RESISTOR	3.3kΩ 1/16W J	
R8022	NRSA63J-331X	MG RESISTOR	330Ω 1/16W J		R8711	NRSA63J-0R0X	MG RESISTOR	0Ω 1/16W J	
					R8713	NRSA63J-332X	MG RESISTOR	3.3kΩ 1/16W J	
					R8715	NRSA63J-102X	MG RESISTOR	1kΩ 1/16W J	

△ Symbol No. Part No. Part Name Description Local

Mechanism control board (KD-LHX557)

Block No. [0][6]

△ Symbol No.	Part No.	Part Name	Description	Local
R8716	NRSA63J-102X	MG RESISTOR	1kΩ 1/16W J	
R8718	NRSA63J-332X	MG RESISTOR	3.3kΩ 1/16W J	
R8719	NRSA63J-822X	MG RESISTOR	8.2kΩ 1/16W J	
R8720	NRSA63J-822X	MG RESISTOR	8.2kΩ 1/16W J	
R8721	NRSA63J-103X	MG RESISTOR	10kΩ 1/16W J	
R8752	NRSA63J-391X	MG RESISTOR	390Ω 1/16W J	
R8753	NRSA63J-391X	MG RESISTOR	390Ω 1/16W J	
R8754	NRSA63J-391X	MG RESISTOR	390Ω 1/16W J	
R8756	NRSA63J-561X	MG RESISTOR	560Ω 1/16W J	
R8757	NRSA63J-561X	MG RESISTOR	560Ω 1/16W J	
R8758	NRSA63J-561X	MG RESISTOR	560Ω 1/16W J	
R8760	NRSA63J-391X	MG RESISTOR	390Ω 1/16W J	
R8761	NRSA63J-391X	MG RESISTOR	390Ω 1/16W J	
R8762	NRSA63J-391X	MG RESISTOR	390Ω 1/16W J	
R8764	NRSA63J-391X	MG RESISTOR	390Ω 1/16W J	
R8765	NRSA63J-391X	MG RESISTOR	390Ω 1/16W J	
R8766	NRSA63J-391X	MG RESISTOR	390Ω 1/16W J	
R8768	NRSA63J-561X	MG RESISTOR	560Ω 1/16W J	
R8769	NRSA63J-561X	MG RESISTOR	560Ω 1/16W J	
R8770	NRSA63J-561X	MG RESISTOR	560Ω 1/16W J	
R8772	NRSA63J-391X	MG RESISTOR	390Ω 1/16W J	
R8773	NRSA63J-391X	MG RESISTOR	390Ω 1/16W J	
R8774	NRSA63J-391X	MG RESISTOR	390Ω 1/16W J	
R8776	NRSA63J-391X	MG RESISTOR	390Ω 1/16W J	
R8777	NRSA63J-391X	MG RESISTOR	390Ω 1/16W J	
R8778	NRSA63J-391X	MG RESISTOR	390Ω 1/16W J	
R8780	NRSA63J-561X	MG RESISTOR	560Ω 1/16W J	
R8781	NRSA63J-561X	MG RESISTOR	560Ω 1/16W J	
R8782	NRSA63J-561X	MG RESISTOR	560Ω 1/16W J	
R8784	NRSA63J-391X	MG RESISTOR	390Ω 1/16W J	
R8785	NRSA63J-391X	MG RESISTOR	390Ω 1/16W J	
R8786	NRSA63J-391X	MG RESISTOR	390Ω 1/16W J	
R8801	NRSA63J-122X	MG RESISTOR	1.2kΩ 1/16W J	
R8802	NRSA63J-122X	MG RESISTOR	1.2kΩ 1/16W J	
R8803	NRSA63J-272X	MG RESISTOR	2.7kΩ 1/16W J	
R8804	NRSA63J-272X	MG RESISTOR	2.7kΩ 1/16W J	
R8805	NRSA63J-182X	MG RESISTOR	1.8kΩ 1/16W J	
R8806	NRSA63J-152X	MG RESISTOR	1.5kΩ 1/16W J	
R8811	NRSA63J-821X	MG RESISTOR	820Ω 1/16W J	
R8812	NRSA63J-821X	MG RESISTOR	820Ω 1/16W J	
R8813	NRSA63J-102X	MG RESISTOR	1kΩ 1/16W J	
R8814	NRSA63J-152X	MG RESISTOR	1.5kΩ 1/16W J	
R8822	NRSA63J-271X	MG RESISTOR	270Ω 1/16W J	
R8825	NRSA63J-331X	MG RESISTOR	330Ω 1/16W J	
R8828	NRSA63J-271X	MG RESISTOR	270Ω 1/16W J	
R8831	NRSA63J-271X	MG RESISTOR	270Ω 1/16W J	
R8834	NRSA63J-331X	MG RESISTOR	330Ω 1/16W J	
R8837	NRSA63J-271X	MG RESISTOR	270Ω 1/16W J	
L8301	NQL79GM-470X	COIL	47uH M	
CN801	NNZ0098-003X	CAR CONNECTOR		
CN851	QGF0523F1-35W	CONNECTOR	FFC/FPC (1-35)	
CN871	QGF1041C1-06W	CONNECTOR	FFC/FPC (1-6)	
S8001	NSW0066-001X	TACT SW		
S8002	NSW0066-001X	TACT SW		
S8003	NSW0066-001X	TACT SW		
S8004	NSW0066-001X	TACT SW		
S8005	NSW0066-001X	TACT SW		
S8006	NSW0218-001X	LUMISWITCH		
S8007	NSW0066-001X	TACT SW		
S8201	NSW0066-001X	TACT SW		
TH801	NAD0028-103X	N THERMISTOR	10kΩ	
X8001	NAX0652-001X	C RESONATOR	25.000MHZ	

△ Symbol No. Part No. Part Name Description Local

△ Symbol No.	Part No.	Part Name	Description	Local
IC430	SN74AHC04PW-X	IC		
IC501	TMP91CY22FG6AP3	IC		
IC502	BR24L01AFV-W-X	IC		
IC503	SN74AHC126PW-X	IC(DIGITAL)		
IC504	NJU7241F33-X	IC		
IC601	TC94A15FG	IC		
IC651	NJU7772F15-X	IC		
IC652	TC94A34FG-002	IC		
IC653	MSM51V17405F5TS	IC		
IC654	SN74CBTLV3257PX	IC		
IC655	SN74AHC1G08V-X	IC		
IC681	LA6242H-X	IC		
Q430	2SB624/4/-X	TRANSISTOR		
Q431	UN2211-X	TRANSISTOR		
Q501	UN2111-X	TRANSISTOR		
Q502	UN2211-X	TRANSISTOR		
Q503	RPM-22PB	PHOTO		
Q504	UN2211-X	TRANSISTOR		
Q601	2SB1132/QR/-W	TRANSISTOR		
Q651	UN2211-X	TRANSISTOR		
Q652	2SB624/4/-X	TRANSISTOR		
Q681	2SB1184/QR/-X	TRANSISTOR		
D506	1SS355-X	SI DIODE		
D682	1SR154-400-X	DIODE		
C431	NDC31HJ-270X	C CAPACITOR	27pF 50V J	
C432	NDC31HJ-270X	C CAPACITOR	27pF 50V J	
C433	NCB31CK-104X	C CAPACITOR	0.1uF 16V K	
C501	NCB31HK-103X	C CAPACITOR	0.01uF 50V K	
C502	NCB31HK-223X	C CAPACITOR	0.022uF 50V K	
C503	NEAD0GM-227X	E CAPACITOR	220uF 4V M	
C504	NDC31HJ-220X	C CAPACITOR	22pF 50V J	
C505	NDC31HJ-220X	C CAPACITOR	22pF 50V J	
C506	NCB31HK-103X	C CAPACITOR	0.01uF 50V K	
C507	NCB31HK-223X	C CAPACITOR	0.022uF 50V K	
C508	NCB31HK-103X	C CAPACITOR	0.01uF 50V K	
C509	NCB31HK-223X	C CAPACITOR	0.022uF 50V K	
C510	NCB31HK-103X	C CAPACITOR	0.01uF 50V K	
C511	NCB31CK-104X	C CAPACITOR	0.1uF 16V K	
C512	NEAD0GM-227X	E CAPACITOR	220uF 4V M	
C513	NCB31HK-103X	C CAPACITOR	0.01uF 50V K	
C514	NDC31HJ-102X	C CAPACITOR	1000pF 50V J	
C516	NEAD0GM-227X	E CAPACITOR	220uF 4V M	
C530	NDC31HJ-102X	C CAPACITOR	1000pF 50V J	
C551	NCB31HK-103X	C CAPACITOR	0.01uF 50V K	
C597	NDC31HJ-102X	C CAPACITOR	1000pF 50V J	
C598	NDC31HJ-102X	C CAPACITOR	1000pF 50V J	
C599	NDC31HJ-102X	C CAPACITOR	1000pF 50V J	
C601	NEAF0JM-107X	E CAPACITOR	100uF 6.3V M	
C602	NCB31HK-681X	C CAPACITOR	680pF 50V K	
C603	NEAF0JM-107X	E CAPACITOR	100uF 6.3V M	
C604	NCB31HK-103X	C CAPACITOR	0.01uF 50V K	
C605	NCB31CK-104X	C CAPACITOR	0.1uF 16V K	
C606	NEAF0JM-476X	E CAPACITOR	47uF 6.3V M	
C607	NCB31CK-104X	C CAPACITOR	0.1uF 16V K	
C608	NCB31CK-104X	C CAPACITOR	0.1uF 16V K	
C610	NCB31CK-104X	C CAPACITOR	0.1uF 16V K	
C612	NCB31HK-103X	C CAPACITOR	0.01uF 50V K	
C613	NCB31HK-103X	C CAPACITOR	0.01uF 50V K	
C614	NCB31HK-103X	C CAPACITOR	0.01uF 50V K	
C615	NCB31CK-224X	C CAPACITOR	0.22uF 16V K	
C616	NEAF0JM-476X	E CAPACITOR	47uF 6.3V M	
C617	NCB31CK-104X	C CAPACITOR	0.1uF 16V K	
C618	NCB31CK-104X	C CAPACITOR	0.1uF 16V K	
C621	NCB31CK-104X	C CAPACITOR	0.1uF 16V K	
C622	NEAF0JM-476X	E CAPACITOR	47uF 6.3V M	
C623	NCS31HJ-470X	C CAPACITOR	47pF 50V J	
C624	NCB31HK-153X	C CAPACITOR	0.015uF 50V K	
C625	NCB31HK-103X	C CAPACITOR	0.01uF 50V K	
C626	NCB31HK-103X	C CAPACITOR	0.01uF 50V K	
C627	NCB31CK-104X	C CAPACITOR	0.1uF 16V K	

△ Symbol No.	Part No.	Part Name	Description	Local	△ Symbol No.	Part No.	Part Name	Description	Local
C629	NCB31EK-333X	C CAPACITOR	0.033uF 25V K		R513	NRSA63J-102X	MG RESISTOR	1kΩ 1/16W J	
C630	NCB31EK-333X	C CAPACITOR	0.033uF 25V K		R514	NRSA63J-473X	MG RESISTOR	47kΩ 1/16W J	
C631	NCS31HJ-471X	C CAPACITOR	470pF 50V J		R515	NRSA63J-473X	MG RESISTOR	47kΩ 1/16W J	
C632	NCS31HJ-471X	C CAPACITOR	470pF 50V J		R516	NRSA63J-102X	MG RESISTOR	1kΩ 1/16W J	
C633	NCB31CK-104X	C CAPACITOR	0.1uF 16V K		R517	NRSA63J-101X	MG RESISTOR	100Ω 1/16W J	
C634	NCB31HK-472X	C CAPACITOR	4700pF 50V K		R518	NRSA63J-101X	MG RESISTOR	100Ω 1/16W J	
C635	NCB31CK-153X	C CAPACITOR	0.015uF 16V K		R519	NRSA63J-101X	MG RESISTOR	100Ω 1/16W J	
C636	NCB31CK-473X	C CAPACITOR	0.047uF 16V K		R520	NRSA63J-101X	MG RESISTOR	100Ω 1/16W J	
C637	NCB31CK-473X	C CAPACITOR	0.047uF 16V K		R521	NRSA63J-101X	MG RESISTOR	100Ω 1/16W J	
C638	NCB31HK-103X	C CAPACITOR	0.01uF 50V K		R522	NRSA63J-101X	MG RESISTOR	100Ω 1/16W J	
C640	NCB31HK-103X	C CAPACITOR	0.01uF 50V K		R523	NRSA63J-101X	MG RESISTOR	100Ω 1/16W J	
C641	NEAF0JM-476X	E CAPACITOR	47uF 6.3V M		R524	NRSA63J-101X	MG RESISTOR	100Ω 1/16W J	
C642	NCS31HJ-101X	C CAPACITOR	100pF 50V J		R526	NRSA63J-473X	MG RESISTOR	47kΩ 1/16W J	
C643	NCB31CK-104X	C CAPACITOR	0.1uF 16V K		R527	NRSA63J-473X	MG RESISTOR	47kΩ 1/16W J	
C644	NCB31AK-334X	C CAPACITOR	0.33uF 10V K		R531	NRSA63J-473X	MG RESISTOR	47kΩ 1/16W J	
C645	NEAF0JM-476X	E CAPACITOR	47uF 6.3V M		R532	NRSA63J-473X	MG RESISTOR	47kΩ 1/16W J	
C646	NCB31CK-104X	C CAPACITOR	0.1uF 16V K		R533	NRSA63J-101X	MG RESISTOR	100Ω 1/16W J	
C647	NCS31HJ-680X	C CAPACITOR	68pF 50V J		R534	NRSA63J-101X	MG RESISTOR	100Ω 1/16W J	
C648	NBE20JM-106X	TA E CAPACITOR	10uF 6.3V M		R539	NRSA63J-473X	MG RESISTOR	47kΩ 1/16W J	
C649	NCB31HK-562X	C CAPACITOR	5600pF 50V K		R540	NRSA63J-473X	MG RESISTOR	47kΩ 1/16W J	
C651	NEAF0JM-476X	E CAPACITOR	47uF 6.3V M		R541	NRSA63J-101X	MG RESISTOR	100Ω 1/16W J	
C652	NCB31HK-103X	C CAPACITOR	0.01uF 50V K		R542	NRSA63J-103X	MG RESISTOR	10kΩ 1/16W J	
C653	NEAF0JM-476X	E CAPACITOR	47uF 6.3V M		R543	NRSA63J-101X	MG RESISTOR	100Ω 1/16W J	
C654	NCB31CK-104X	C CAPACITOR	0.1uF 16V K		R544	NRSA63J-101X	MG RESISTOR	100Ω 1/16W J	
C655	NCB31HK-103X	C CAPACITOR	0.01uF 50V K		R545	NRSA63J-103X	MG RESISTOR	10kΩ 1/16W J	
C656	NCB31CK-104X	C CAPACITOR	0.1uF 16V K		R546	NRSA63J-271X	MG RESISTOR	270Ω 1/16W J	
C658	NEAF0JM-476X	E CAPACITOR	47uF 6.3V M		R547	NRSA63J-271X	MG RESISTOR	270Ω 1/16W J	
C659	NCB31CK-104X	C CAPACITOR	0.1uF 16V K		R548	NRSA63D-822X	MG RESISTOR	8.2kΩ 1/16W D	
C660	NCS31HJ-101X	C CAPACITOR	100pF 50V J		R549	NRSA63J-472X	MG RESISTOR	4.7kΩ 1/16W J	
C661	NCB31HK-103X	C CAPACITOR	0.01uF 50V K		R550	NRSA63J-472X	MG RESISTOR	4.7kΩ 1/16W J	
C662	NCS31HJ-101X	C CAPACITOR	100pF 50V J		R551	NRSA63J-104X	MG RESISTOR	100kΩ 1/16W J	
C663	NCB31CK-104X	C CAPACITOR	0.1uF 16V K		R552	NRSA63J-104X	MG RESISTOR	100kΩ 1/16W J	
C664	NCB31HK-222X	C CAPACITOR	2200pF 50V K		R553	NRSA63J-183X	MG RESISTOR	18kΩ 1/16W J	
C665	NCB31CK-104X	C CAPACITOR	0.1uF 16V K		R554	NRSA63J-333X	MG RESISTOR	33kΩ 1/16W J	
C666	NCS31HJ-101X	C CAPACITOR	100pF 50V J		R555	NRSA63J-101X	MG RESISTOR	100Ω 1/16W J	
C668	NEAF0JM-476X	E CAPACITOR	47uF 6.3V M		R556	NRSA63J-0R0X	MG RESISTOR	0Ω 1/16W J	
C669	NCB31HK-103X	C CAPACITOR	0.01uF 50V K		R557	NRSA63J-104X	MG RESISTOR	100kΩ 1/16W J	
C670	NCB31CK-104X	C CAPACITOR	0.1uF 16V K		R558	NRSA63J-104X	MG RESISTOR	100kΩ 1/16W J	
C671	NBE21AM-106X	TA E CAPACITOR	10uF 10V M		R559	NRSA63J-0R0X	MG RESISTOR	0Ω 1/16W J	
C672	NCB31CK-104X	C CAPACITOR	0.1uF 16V K		R560	NRSA63J-101X	MG RESISTOR	100Ω 1/16W J	
C674	NCB31CK-104X	C CAPACITOR	0.1uF 16V K		R561	NRSA63J-104X	MG RESISTOR	100kΩ 1/16W J	
C675	NBE20JM-106X	TA E CAPACITOR	10uF 6.3V M		R562	NRSA63J-392X	MG RESISTOR	3.9kΩ 1/16W J	
C677	NDC31HJ-471X	C CAPACITOR	470pF 50V J		R563	NRSA63J-682X	MG RESISTOR	6.8kΩ 1/16W J	
C678	NDC31HJ-471X	C CAPACITOR	470pF 50V J		R564	NRSA63J-101X	MG RESISTOR	100Ω 1/16W J	
C680	NCB31CK-104X	C CAPACITOR	0.1uF 16V K		R565	NRSA63J-101X	MG RESISTOR	100Ω 1/16W J	
C682	NEAF1EM-475X	E CAPACITOR	4.7uF 25V M		R566	NRSA63J-101X	MG RESISTOR	100Ω 1/16W J	
C683	NCB31CK-104X	C CAPACITOR	0.1uF 16V K		R567	NRSA63J-473X	MG RESISTOR	47kΩ 1/16W J	
C684	NEAF1CM-476X	E CAPACITOR	47uF 16V M		R568	NRSA63J-102X	MG RESISTOR	1kΩ 1/16W J	
C685	NCB31CK-473X	C CAPACITOR	0.047uF 16V K		R569	NRSA63J-102X	MG RESISTOR	1kΩ 1/16W J	
C686	NCB31CK-473X	C CAPACITOR	0.047uF 16V K		R570	NRSA63J-102X	MG RESISTOR	1kΩ 1/16W J	
C687	NCB31CK-473X	C CAPACITOR	0.047uF 16V K		R571	NRSA63J-473X	MG RESISTOR	47kΩ 1/16W J	
C688	NCB31CK-473X	C CAPACITOR	0.047uF 16V K		R573	NRSA63J-332X	MG RESISTOR	3.3kΩ 1/16W J	
C689	NEAF1CM-476X	E CAPACITOR	47uF 16V M		R574	NRSA63J-332X	MG RESISTOR	3.3kΩ 1/16W J	
C690	NBE20JM-106X	TA E CAPACITOR	10uF 6.3V M		R575	NRSA63J-470X	MG RESISTOR	47Ω 1/16W J	
C693	NEAF1CM-476X	E CAPACITOR	47uF 16V M		R576	NRSA63J-470X	MG RESISTOR	47Ω 1/16W J	
C907	NEAF0JM-476X	E CAPACITOR	47uF 6.3V M		R577	NRSA63J-101X	MG RESISTOR	100Ω 1/16W J	
C908	NCB31CK-104X	C CAPACITOR	0.1uF 16V K		R578	NRSA63J-101X	MG RESISTOR	100Ω 1/16W J	
					R579	NRSA63J-101X	MG RESISTOR	100Ω 1/16W J	
R431	NRSA63J-225X	MG RESISTOR	2.2MΩ 1/16W J		R580	NRSA63J-101X	MG RESISTOR	100Ω 1/16W J	
R432	NRSA63J-102X	MG RESISTOR	1kΩ 1/16W J		R581	NRSA63J-101X	MG RESISTOR	100Ω 1/16W J	
R434	NRSA63J-0R0X	MG RESISTOR	0Ω 1/16W J		R582	NRSA63J-101X	MG RESISTOR	100Ω 1/16W J	
R437	NRSA63J-102X	MG RESISTOR	1kΩ 1/16W J		R583	NRSA63J-101X	MG RESISTOR	100Ω 1/16W J	
R438	NRSA63J-102X	MG RESISTOR	1kΩ 1/16W J		R584	NRSA63J-101X	MG RESISTOR	100Ω 1/16W J	
R439	NRSA63J-101X	MG RESISTOR	100Ω 1/16W J		R585	NRSA63J-101X	MG RESISTOR	100Ω 1/16W J	
R440	NRSA63J-473X	MG RESISTOR	47kΩ 1/16W J		R586	NRSA63J-101X	MG RESISTOR	100Ω 1/16W J	
R441	NRSA63J-222X	MG RESISTOR	2.2kΩ 1/16W J		R587	NRSA63J-101X	MG RESISTOR	100Ω 1/16W J	
R501	NRSA63J-102X	MG RESISTOR	1kΩ 1/16W J		R588	NRSA63J-101X	MG RESISTOR	100Ω 1/16W J	
R502	NRSA63J-102X	MG RESISTOR	1kΩ 1/16W J		R589	NRSA63J-101X	MG RESISTOR	100Ω 1/16W J	
R503	NRSA63J-102X	MG RESISTOR	1kΩ 1/16W J		R590	NRSA63J-101X	MG RESISTOR	100Ω 1/16W J	
R504	NRSA63J-101X	MG RESISTOR	100Ω 1/16W J		R591	NRSA63J-101X	MG RESISTOR	100Ω 1/16W J	
R505	NRSA63J-101X	MG RESISTOR	100Ω 1/16W J		R592	NRSA63J-473X	MG RESISTOR	47kΩ 1/16W J	
R506	NRSA63J-473X	MG RESISTOR	47kΩ 1/16W J		R593	NRSA63J-0R0X	MG RESISTOR	0Ω 1/16W J	
R507	NRSA63J-473X	MG RESISTOR	47kΩ 1/16W J		R594	NRSA63J-473X	MG RESISTOR	47kΩ 1/16W J	
R508	NRSA63J-473X	MG RESISTOR	47kΩ 1/16W J		R599	NRSA63J-101X	MG RESISTOR	100Ω 1/16W J	
R509	NRSA63J-473X	MG RESISTOR	47kΩ 1/16W J		R601	NRSA63J-0R0X	MG RESISTOR	0Ω 1/16W J	
R510	NRSA63J-101X	MG RESISTOR	100Ω 1/16W J		R602	NRSA63J-0R0X	MG RESISTOR	0Ω 1/16W J	
R511	NRSA63J-102X	MG RESISTOR	1kΩ 1/16W J		R603	NRSA63D-183X	MG RESISTOR	18kΩ 1/16W D	
R512	NRSA63J-473X	MG RESISTOR	47kΩ 1/16W J		R604	NRSA63D-183X	MG RESISTOR	18kΩ 1/16W D	

△ Symbol No.	Part No.	Part Name	Description	Local	△ Symbol No.	Part No.	Part Name	Description	Local
R605	NRSA63J-220X	MG RESISTOR	22Ω 1/16W J		L901	NQL114K-470X	COIL	47uH K	
R606	NRSA63J-220X	MG RESISTOR	22Ω 1/16W J		CN502	QGF0501F1-08X	CONNECTOR	FFC/FPC (1-8)	
R609	NRSA63J-473X	MG RESISTOR	47kΩ 1/16W J		CN503	QGB2027L5-20X	CONNECTOR	B-B (1-20)	
R611	NRSA63J-473X	MG RESISTOR	47kΩ 1/16W J		CN601	QGF1006F2-15W	CONNECTOR	FFC/FPC (1-15)	
R612	NRSA63J-0R0X	MG RESISTOR	0Ω 1/16W J		CN602	QGF1038F1-05X	CONNECTOR	FFC/FPC (1-5)	
R613	NRSA63J-101X	MG RESISTOR	100Ω 1/16W J		CN901	NNZ0104-001X	SD CARD CONNE		
R614	NRSA63J-101X	MG RESISTOR	100Ω 1/16W J		SW4	NSW0219-001X	PUSH SWITCH		
R615	NRSA63J-151X	MG RESISTOR	150Ω 1/16W J		SW5	NSW0219-001X	PUSH SWITCH		
R617	NRSA63J-473X	MG RESISTOR	47kΩ 1/16W J		TH501	NAD0028-103X	N THERMISTOR	10kΩ	
R618	NRSA63J-101X	MG RESISTOR	100Ω 1/16W J		X430	NAX0375-001X	CRYSTAL	16.9344MHz	
R619	NRSA63J-101X	MG RESISTOR	100Ω 1/16W J		X501	NAX0385-001X	CRYSTAL	24.576MHz	
R621	NRSA63J-470X	MG RESISTOR	47Ω 1/16W J						
R622	NRSA63J-470X	MG RESISTOR	47Ω 1/16W J						
R623	NRSA63J-470X	MG RESISTOR	47Ω 1/16W J						
R624	NRSA63J-562X	MG RESISTOR	5.6kΩ 1/16W J						
R625	NRSA63J-473X	MG RESISTOR	47kΩ 1/16W J						
R626	NRSA63J-474X	MG RESISTOR	470kΩ 1/16W J						
R627	NRSA63J-183X	MG RESISTOR	18kΩ 1/16W J						
R628	NRSA63J-225X	MG RESISTOR	2.2MΩ 1/16W J						
R629	NRSA63J-223X	MG RESISTOR	22kΩ 1/16W J						
R630	NRSA63J-101X	MG RESISTOR	100Ω 1/16W J						
R631	NRSA63J-103X	MG RESISTOR	10kΩ 1/16W J						
R632	NRSA63J-473X	MG RESISTOR	47kΩ 1/16W J						
R635	NRSA63J-101X	MG RESISTOR	100Ω 1/16W J						
R636	NRSA63J-101X	MG RESISTOR	100Ω 1/16W J						
R637	NRSA63J-105X	MG RESISTOR	1MΩ 1/16W J						
R638	NRSA63J-472X	MG RESISTOR	4.7kΩ 1/16W J						
R639	NRSA63J-472X	MG RESISTOR	4.7kΩ 1/16W J						
R640	NRSA63J-472X	MG RESISTOR	4.7kΩ 1/16W J						
R641	NRSA63J-472X	MG RESISTOR	4.7kΩ 1/16W J						
R642	NRSA63J-103X	MG RESISTOR	10kΩ 1/16W J						
R643	NRSA63J-332X	MG RESISTOR	3.3kΩ 1/16W J						
R651	NRSA63J-104X	MG RESISTOR	100kΩ 1/16W J						
R653	NRSA63J-0R0X	MG RESISTOR	0Ω 1/16W J						
R655	NRSA63J-0R0X	MG RESISTOR	0Ω 1/16W J						
R656	NRSA63J-222X	MG RESISTOR	2.2kΩ 1/16W J						
R657	NRSA63J-473X	MG RESISTOR	47kΩ 1/16W J						
R658	NRSA63J-473X	MG RESISTOR	47kΩ 1/16W J						
R659	NRSA63J-101X	MG RESISTOR	100Ω 1/16W J						
R660	NRSA63J-101X	MG RESISTOR	100Ω 1/16W J						
R661	NRSA63J-101X	MG RESISTOR	100Ω 1/16W J						
R665	NRSA63J-101X	MG RESISTOR	100Ω 1/16W J						
R666	NRSA63J-101X	MG RESISTOR	100Ω 1/16W J						
R675	NRSA63J-221X	MG RESISTOR	220Ω 1/16W J						
R678	NRSA63J-101X	MG RESISTOR	100Ω 1/16W J						
R680	NRSA63J-243X	MG RESISTOR	24kΩ 1/16W J						
R681	NRSA63J-682X	MG RESISTOR	6.8kΩ 1/16W J						
R682	NRSA63J-822X	MG RESISTOR	8.2kΩ 1/16W J						
R683	NRSA63J-562X	MG RESISTOR	5.6kΩ 1/16W J						
R684	NRSA63J-0R0X	MG RESISTOR	0Ω 1/16W J						
R685	NRSA63J-0R0X	MG RESISTOR	0Ω 1/16W J						
R686	NRSA63J-0R0X	MG RESISTOR	0Ω 1/16W J						
R687	NRSA63J-223X	MG RESISTOR	22kΩ 1/16W J						
R688	NRSA63D-163X	MG RESISTOR	16kΩ 1/16W D						
R689	NRSA63D-103X	MG RESISTOR	10kΩ 1/16W D						
R901	NRSA63J-220X	MG RESISTOR	22Ω 1/16W J						
R902	NRSA63J-220X	MG RESISTOR	22Ω 1/16W J						
R903	NRSA63J-220X	MG RESISTOR	22Ω 1/16W J						
R904	NRSA63J-220X	MG RESISTOR	22Ω 1/16W J						
R905	NRSA63J-220X	MG RESISTOR	22Ω 1/16W J						
R906	NRSA63J-220X	MG RESISTOR	22Ω 1/16W J						
R907	NRSA63J-220X	MG RESISTOR	22Ω 1/16W J						
R908	NRSA63J-473X	MG RESISTOR	47kΩ 1/16W J						
R909	NRSA63J-473X	MG RESISTOR	47kΩ 1/16W J						
L432	NQL093K-1R8X	COIL	1.8uH K						
L501	NQL114K-470X	COIL	47uH K						
L502	NQL114K-470X	COIL	47uH K						
L621	NQL114K-470X	COIL	47uH K						
L622	NQL114K-470X	COIL	47uH K						
L623	NQL114K-470X	COIL	47uH K						
L624	NQL114K-470X	COIL	47uH K						
L651	NQL114K-470X	COIL	47uH K						
L652	NQL114K-470X	COIL	47uH K						
L653	NQL114K-470X	COIL	47uH K						
L654	NQL114K-470X	COIL	47uH K						
L655	NQL114K-470X	COIL	47uH K						
L656	NQL114K-470X	COIL	47uH K						

<MEMO>

Packing materials and accessories parts list

Block No. **M 3 M M**

No additional / supplemental order of WARRANTY CARDS are available.

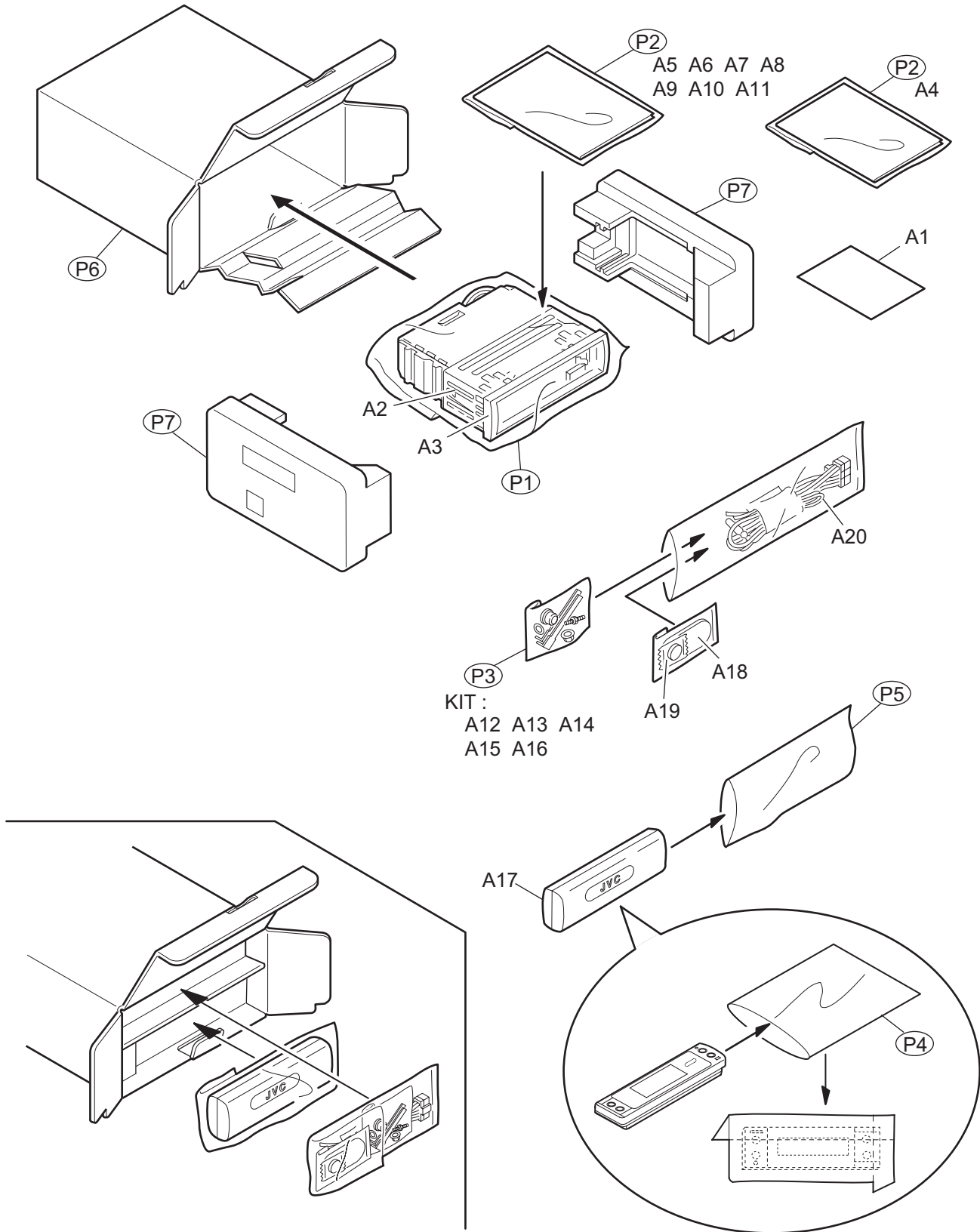

Packing and Accessories

Block No. [M][3][M][M]

△ Symbol No.	Part No.	Part Name	Description	Local
A 1	VND3050-002	IDENTITY CARD		LHX551E,LHX551EX,LHX551EY,LHX552E, LHX552EX,LHX552EY
A 2	GE20137-003A	MOUNTING SLEEVE		
A 3	LV21648-201A	TRIM PLATE		LHX551E,LHX551EU,LHX551EX,LHX551EY LHX552E,LHX552EU,LHX552EX,LHX552EY, LHX557EE
A 3	LV21648-202A	TRIM PLATE		LHX551E,LHX552E
A 4	GET0284-001A	INST BOOK	GER FRE ITA	LHX551E,LHX551EX,LHX552EU,LHX552EX
A 4	GET0284-003A	INST BOOK	ENG FRE	LHX551EY,LHX552EY
A 4	GET0284-006A	INST BOOK	ENG GER RUS	LHX557EE
A 4	GET0285-001A	INST BOOK	ENG RUS	LHX551E,LHX552E
A 5	GET0284-002A	INST BOOK	SPA GRE POR	LHX551EU,LHX552EU
A 5	GET0284-005A	INST BOOK	SPA TUR PER	LHX551EX,LHX552EX
A 5	GET0284-004A	INST BOOK	DUT SWE DAN FIN	LHX551EY,LHX552EY
A 5	GET0284-007A	INST BOOK	POL CZE HUN	LHX557EE
A 5	GET0285-002A	INSTALL MANUAL		LHX551E,LHX552E
A 6	GET0284-008A	INSTALL MANUAL		LHX551EU,LHX551EX,LHX552EU,LHX552EX
A 6	GET0284-010A	INSTALL MANUAL		LHX551EY,LHX552EY
A 6	GET0284-013A	INSTALL MANUAL		LHX551E,LHX552E
A 7	GET0284-009A	INSTALL MANUAL		LHX551EU,LHX552EU
A 7	GET0284-012A	INSTALL MANUAL		LHX551EX,LHX552EX
A 7	GET0284-011A	INSTALL MANUAL		LHX551EY,LHX552EY
A 7	GET0284-014A	INSTALL MANUAL		
A 8	LVT1299-003A	IMAGE CONV.SHT		
A 9	VND3046-001	SERIAL TICKET		LHX551E,LHX551EX,LHX551EY,LHX552E, LHX552EX,LHX552EY,LHX557EE
A 10	-----	WARRANTY CARD	BT-54023-1	LHX551E,LHX551EX,LHX551EY,LHX552E, LHX552EX,LHX552EY,LHX557EE
A 11	QAM0689-001	CD ROM		
A 12	VKZ4027-202	PLUG NUT		
A 13	VKH4871-003	MOUNT BOLT		
A 14	VKZ4328-003	LOCK NUT		
A 15	QYWWS53A008ZA	WASHER	0mm/5.3mm x (x2)	
A 16	GE40130-002A	HOOK		
A 17	FSJB3002-00F	HARD CASE ASSY		
A 18	RM-RK300	REMOCON		
A 19	-----	BATTERY		
A 20	QAM0569-002	POWER CORD		
KIT	SRW-385U	SCREW PART KIT	A12 A13 A14 A15 A16	
P 1	QPC03004315P	POLY BAG	30cm x 43cm	
P 2	FSPG4002-001	POLY BAG	(x2)	LHX551E,LHX551EU,LHX551EX,LHX551EY, LHX552E,LHX552EU,LHX552EX,LHX552EY, LHX557EE
P 2	FSPG4002-001	POLY BAG		
P 3	QPA00801205	POLY BAG	8cm x 12cm	
P 4	QPC01002515	POLY BAG	10cm x 25cm	
P 5	QPA01003003	POLY BAG	10cm x 30cm	
P 6	GE31549-002A	CARTON		LHX551E,LHX551EU,LHX551EX,LHX551EY
P 6	GE31552-002A	CARTON		LHX552E,LHX552EU,LHX552EX,LHX552EY
P 6	GE31622-003A	CARTON		LHX557EE
P 7	GE10086-004A	CUSHION	(x2)	