

5-CH BTL DRIVER FOR DVD PLAYER WITH DISC BIDIRECTINAL DRIVER

DESCRIPTION

The SA5668 is a five-channel BTL driver IC for driving the motors and actuators in products such as CD - ROM / DVD drivers. It is also build-in one channel bi-direction DC motor driver for tray.

FEATURES

- * Wide dynamic range (4.0V (Typ.) when $V_{CC} = 12V$, $PV_{CC} = 5V$, and $R_L = 8\Omega$).
- * Level shift circuit on chip.
- * Thermal shutdown circuit on chip.
- * Mute mode built-in.
- * Five drivers build-in: dual actuator drivers, sled motor driver, spindle driver and tray in-out driver.

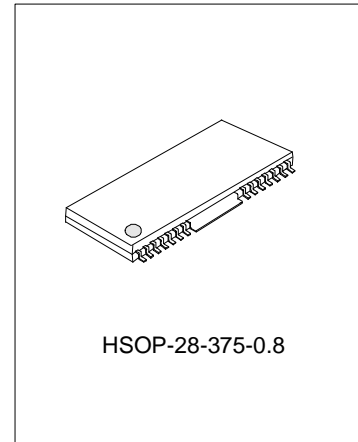

APPLICATIONS

- * CD
- * CD-ROM
- * DVD

ORDERING INFORMATION

Part No.	Package
SA5668	HSOP-28-375-0.8

BLOCK DIAGRAM

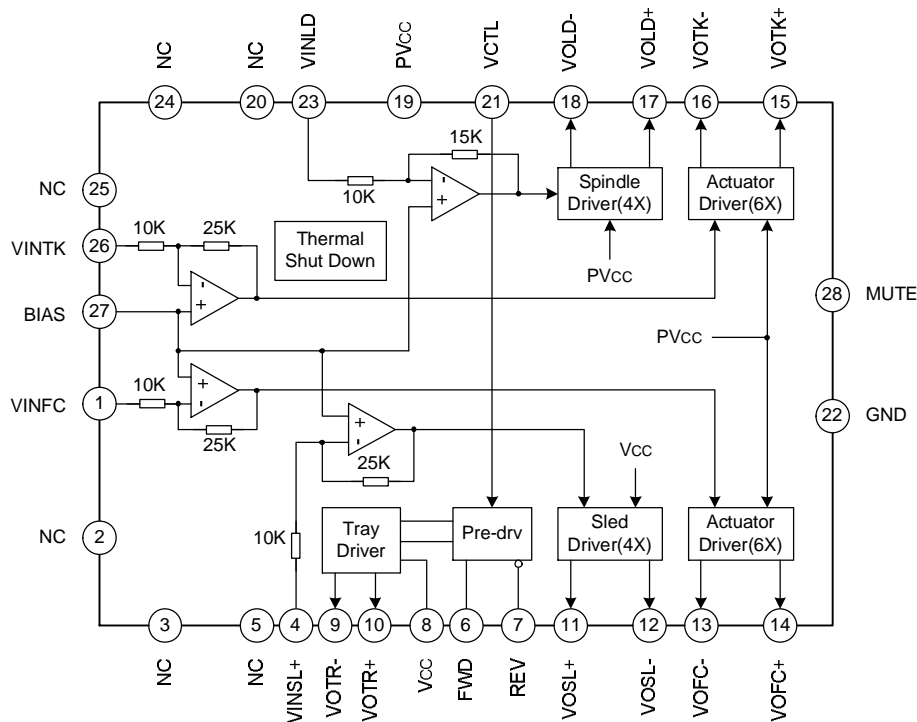

ABSOLUTE MAXIMUM RATING (Tamb=25°C)

Characteristics	Symbol	Value	Unit
Power Supply Voltage	VCC, PVCC	13.5	V
Power Dissipation	PD	1.7*	W
Operating Temperature	Topr	-35~+85	°C
Storage Temperature	Tstg	-55~+150	°C

* When mounted on a 70mm X 70mm X 1.6mm glass epoxy board.
Reduced by 13.6mW for each increase in Tamb of 1°C over 25°C.

ELECTRICAL CHARACTERISTICS

(Unless other specified, Tamb=25°C, VCC=12V, PVCC=5V, BIAS=2.5V, RL=8Ω/10Ω/20Ω/45Ω)

Characteristics	Symbol	Test conditions	Min.	Typ.	Max.	Unit
Quiescent Current	Icc		--	30		mA
Actuator Driver						
Output Offset Voltage	Voo		-6	--	6	mA
Maximum Output Amplitude	VOM		3.6	4.0	--	V
Voltage Gain	Gv	VIN=BIAS ±0.2V	--	23.5	--	dB
Spindle Driver						
Input Op-Amp Same Phase Input Range	VICM		-0.3	--	11.0	V
Input Bias Current (Outflow Current)	IBOP		--	30	300	nA
Output High Level Voltage	VOHOP	No load	10.8	11.1	--	V
Output Low Level Voltage	VOLOP	No load	--	0.8	1.1	V
Output Offset Voltage	VOOFLD		-100	0	100	mV
Maximum Output Amplitude	VOMLD		7.5	9.0	--	V
Closed-Circuit Voltage Gain	GVLD	VIN=BIAS ±0.2V	18.0	20.0	22.0	dB
Sled Driver						
Offset Voltage	VOOFSL		-50	0	50	mV
Maximum Output Amplitude	VOMSL		3.6	4.0	--	V
Voltage Gain	GVSL	VIN=BIAS ±0.2V	13.5	15.5	17.5	dB
F/R Gain Differential	ΔGVSL	VIN=BIAS ±0.2V	0	1	2	dB
STBY Logic						
STBY On Voltage	VSTBY1	All Channels Off	0	--	0.5	V
STBY Off Voltage	VSTBY2	All Channels On	2.0	--	--	V
Tray Motor Driver Input Logic						
High Level Input Voltage	VIH		1.5	-	VCC	V
Low Level Input Voltage	VIL		-0.3	-	0.5	V
High Level Input Current	IiH	VFWD=VREV=5V	-	180	270	μA

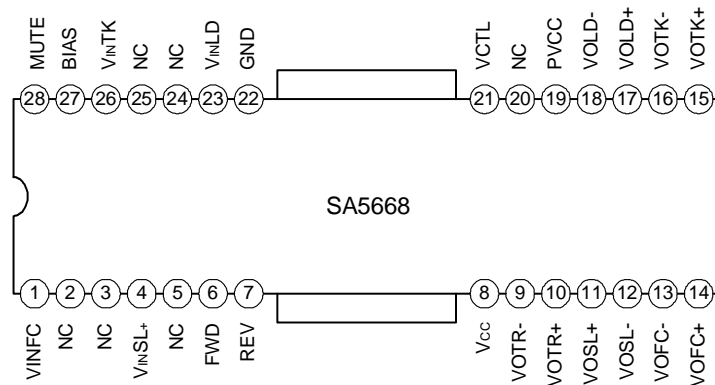
PIN CONFIGURATION

PIN DESCRIPTIONS

Pin No.	Pin Name	Descriptions
1	VINFC	Focus driver input
2	NC	Unconnected
3	NC	Unconnected
4	VINSL+	Sled driver input
5	NC	Unconnected
6	FWD	Tray driver forward input
7	REV	Tray driver reverse input
8	VCC	VCC
9	VOTR-	Tray driver output(-)
10	VOTR+	Tray driver output(+)
11	VOSL+	Sled driver output (+)
12	VOSL-	Sled driver output (-)
13	VOFC-	Focus driver output (-)
14	VOFC+	Focus driver output (+)
15	VOTK+	Tracking driver output (+)
16	VOTK-	Tracking driver output (-)
17	VOLD+	Spindle driver output (+)
18	VOLD-	Spindle driver output (-)
19	PVCC	Vcc for power block of spindle, tracking and focus
20	NC	Unconnected

(To be continued)

(Continued)

Pin No.	Pin Name	Description
21	VCTL	Speed control input of tray driver
22	GND	Ground
23	VINLD	Spindle driver input
24	NC	Unconnected
25	NC	Unconnected
26	VINTK	Tracking driver input
27	BIAS	Bias input
28	MUTE	Standby

Notes: The indicated polarities for the output pins are means polarity to inputs.

Always ensure that $V_{CC} \geq PV_{CC}$

FUNCTION DESCRIPTION

Operation notes

- (1) This IC has a built in thermal shutdown circuit that mutes the output current when the chip temperature reaches 175°C (typ.). The hysteresis is set to 25 °C (typ.), so the driver circuits start up again when the chip temperature falls to 150° C (typ.).
- (2) The driver buffer is switched off when the supply voltage falls below 3.6V (typ.), and is switched back on when the voltage reaches 3.8V (typ.) again.
- (3) Bias pin (pin27) should be pulled up to more than 1.2V. In case the bias pin voltage is pulled down below 0.9V (Typ), the output current is muted.
- (4) The stand by circuit logic is active low.
- (5) Mute is applied when the buffer pin voltage falls below 0.6V (typ.). Normally, operate with this pin at 2.0V at least.
- (6) Connect a bypass capacitor between the bases of the power supply pins of this IC.
- (7) Tray driver logic input:

FWD(pin6)	REV(pin7)	VOTR+(pin10)	VOTR-(pin9)	Function
L	L	OPEN	OPEN	Open mode
L	H	L	H	Reverse mode
H	L	H	L	Forward mode
H	H	L	L	Brake mode

The design of 6,7 pin, consider the driver upper and lower unable ducting at the same time, be sure to do it, the motor forward and reverse input by the open mode, and the interval of the open mode is more than 10ms.

Output high level voltage (VOL+, VOL-) ,varied with the motor controller, it can output 3 times voltage of 21pin, and in high level. In this time, the low level voltage input power pipe as the output saturation voltage.

ELECTRICAL CHARACTERISTICS CURVES

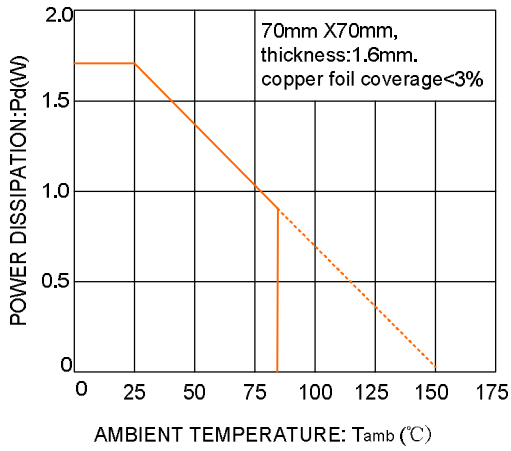

Fig 1. Thermal dissipation curve

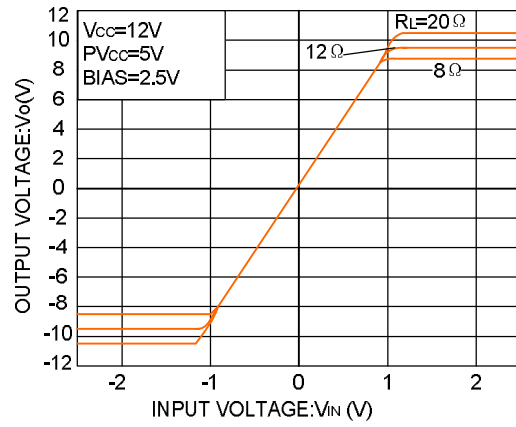

Fig 2. Driver I/O characteristics (Spindle)

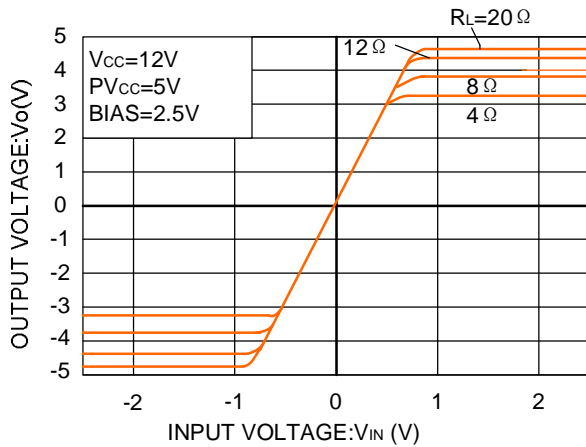
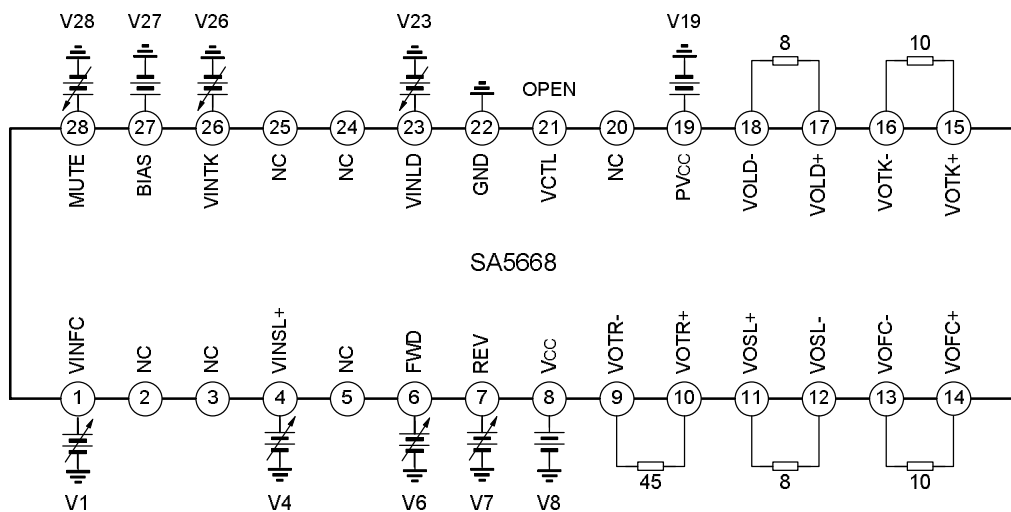
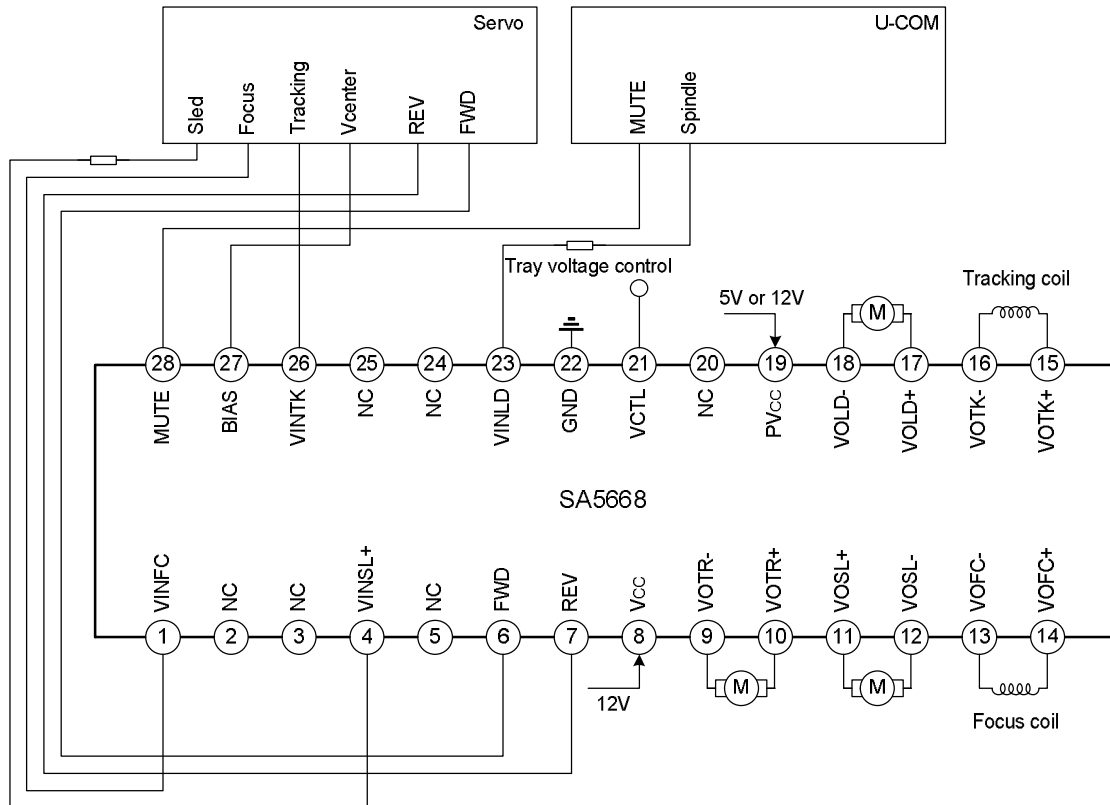

Fig 3. Driver I/O characteristics (sled)

TEST CIRCUIT



TYPICAL APPLICATION CIRCUIT



PACKAGE OUTLINE

