



Internal Use Only

website:<http://biz.LGservice.com>

PLASMA TV

SERVICE MANUAL

CHASSIS : PD81A

MODEL : 32PG6000

32PG6000-ZA

CAUTION

BEFORE SERVICING THE CHASSIS,
READ THE SAFETY PRECAUTIONS IN THIS MANUAL.

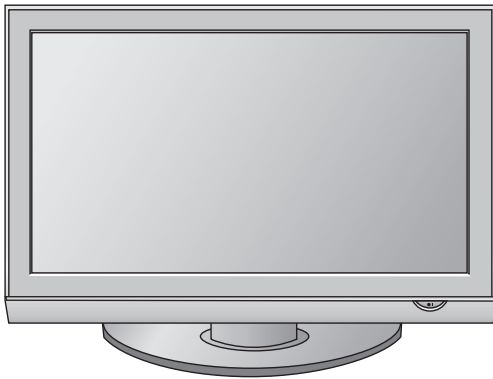

CONTENTS

CONTENTS	2
SAFETY PRECAUTIONS	3
SPECIFICATION	4
ADJUSTMENT INSTRUCTION	7
TROUBLE SHOOTING	12
BLOCK DIAGRAM.....	21
EXPLODED VIEW	30
SVC. SHEET	
PRINTED CIRCUIT DIAGRAM	

SAFETY PRECAUTIONS

IMPORTANT SAFETY NOTICE

Many electrical and mechanical parts in this chassis have special safety-related characteristics. These parts are identified by \triangle in the Schematic Diagram and Replacement Parts List.

It is essential that these special safety parts should be replaced with the same components as recommended in this manual to prevent X-RADIATION, Shock, Fire, or other Hazards.

Do not modify the original design without permission of manufacturer.

General Guidance

An **isolation Transformer should always be used** during the servicing of a receiver whose chassis is not isolated from the AC power line. Use a transformer of adequate power rating as this protects the technician from accidents resulting in personal injury from electrical shocks.

It will also protect the receiver and its components from being damaged by accidental shorts of the circuitry that may be inadvertently introduced during the service operation.

If any fuse (or Fusible Resistor) in this monitor is blown, replace it with the specified.

When replacing a high wattage resistor (Oxide Metal Film Resistor, over 1W), keep the resistor 10mm away from PCB.

Keep wires away from high voltage or high temperature parts.

Due to high vacuum and large surface area of picture tube, extreme care should be used in **handling the Picture Tube**. Do not lift the Picture tube by its Neck.

Leakage Current Cold Check(Antenna Cold Check)

With the instrument AC plug removed from AC source, connect an electrical jumper across the two AC plug prongs. Place the AC switch in the on position, connect one lead of ohm-meter to the AC plug prongs tied together and touch other ohm-meter lead in turn to each exposed metallic parts such as antenna terminals, phone jacks, etc.

If the exposed metallic part has a return path to the chassis, the measured resistance should be between $1M\Omega$ and $5.2M\Omega$.

When the exposed metal has no return path to the chassis the reading must be infinite.

An other abnormality exists that must be corrected before the receiver is returned to the customer.

Leakage Current Hot Check (See below Figure)

Plug the AC cord directly into the AC outlet.

Do not use a line Isolation Transformer during this check.

Connect 1.5K/10watt resistor in parallel with a 0.15uF capacitor between a known good earth ground (Water Pipe, Conduit, etc.) and the exposed metallic parts.

Measure the AC voltage across the resistor using AC voltmeter with 1000 ohms/volt or more sensitivity.

Reverse plug the AC cord into the AC outlet and repeat AC voltage measurements for each exposed metallic part. Any voltage measured must not exceed 0.75 volt RMS which corresponds to 0.5mA.

In case any measurement is out of the limits specified, there is possibility of shock hazard and the set must be checked and repaired before it is returned to the customer.

Leakage Current Hot Check circuit

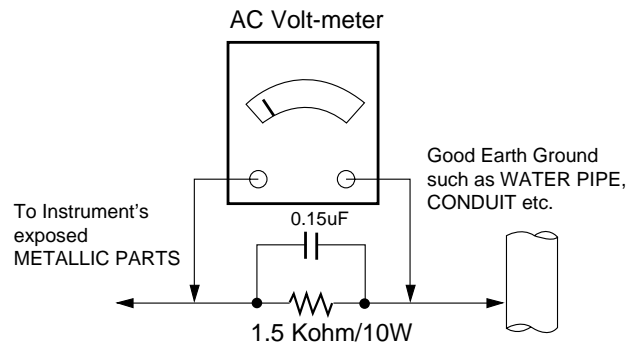

SPECIFICATIONS

NOTE : Specifications and others are subject to change without notice for improvement.

√ Application Range

This spec is applied to the PD81A Chassis.

Chassis	Model Name	Market	Brand
PD81A	50PG6000/42PG6000/ 32PG6000/50PG7000/ 60PG7000/50PG4000	Austria,Belgium,Bulgaria,Coratia,Czech,Denmark,Finland,France,Germany,Greece,Hungary,Italy,Luxembourg, Netherlands,Norway,Poland,Portugal,Rumania,Russia, Serbia,Slovenia,Spain,Sweden,Switzerland,UK,Morocco,Turkey	LG

√ Specification

Each part is tested as below without special appointment.

- 1) Temperature : 25±5°C (77±9°F), CST : 40±5
- 2) Relative Humidity: 65±10%
- 3) Power Voltage: Standard Input voltage (100-240V~, 50/60Hz)
* Standard Voltage of each product is marked by models.
- 4) Specification and performance of each parts are followed each drawing and specification by part number in accordance with SBOM.
- 5) The receiver must be operated for about 20 minutes prior to the adjustment.

√ Test Method

- 1) Performance : LGE TV test method followed.
- 2) Demanded other specification
Safety : CE, IEC specification
EMC : CE, IEC specification

Model	Market	Appliance
50PG6000/42PG6000/ 32PG6000/50PG7000/ 60PG7000/50PG4000	Austria,Belgium,Bulgaria,Coratia,Czech,Denmark,Finland,France, Germany,Greece,Hungary,Italy,Luxembourg, Netherlands,Norway,Poland,Portugal,Rumania,Russia, Serbia,Slovenia,Spain,Sweden,Switzerland,UK,Morocco,Turkey	Safety : IEC/EN60065 EMI : EN55013 EMS : EN55020

√ Module General Specification

(1) 50" WXGA Module

No	Item	Specification	Remark
1	Display Screen Device	50 inch Wide Color Display Module	PDP
2	Aspect Ratio	16:9	
3	PDP Module	PDP50G1####, RGB Closed(Well) Type, Glass Filter(38%) Pixel Format : 1365 horiz. By 768 ver.	
4	Operating Environment	1) Temp. : 0 ~ 40 deg 2) Humidity : 20 ~ 80 %	LGE SPEC.
5	Storage Environment	3) Temp. : -20 ~ 60 deg 4) Humidity : 10 ~ 90 %	
6	Input Voltage	100-240V~, 50/60Hz	Maker LG

(2) 42" XGA Module

No	Item	Specification	Remark
1	Display Screen Device	42 inch Wide Color Display Module	PDP
2	Aspect Ratio	16:9	
3	PDP Module	PDP42G1####, RGB Closed(Well) Type, Glass Filter(38%) Pixel Format : 1024 horiz. By 768 ver.	
4	Operating Environment	1) Temp. : 0 ~ 40 deg 2) Humidity : 20 ~ 80 %	LGE SPEC.
5	Storage Environment	3) Temp. : -20 ~ 60 deg 4) Humidity : 10 ~ 90 %	
6	Input Voltage	100-240V~, 50/60Hz	Maker LG

(3) 50" FHD Module

No	Item	Specification	Remark
1	Display Screen Device	50 inch Wide Color Display Module	PDP
2	Aspect Ratio	16:9	
3	PDP Module	PDP50H2####, RGB Closed(Well) Type, Glass Filter(38%) Pixel Format : 1920 horiz. By 1080 ver.	
4	Operating Environment	1) Temp. : 0 ~ 40 deg 2) Humidity : 20 ~ 80 %	LGE SPEC.
5	Storage Environment	3) Temp. : -20 ~ 60 deg 4) Humidity : 10 ~ 90 %	
6	Input Voltage	100-240V~, 50/60Hz	Maker LG

(4) 60" FHD Module

No	Item	Specification	Remark
1	Display Screen Device	60 inch Wide Color Display Module	PDP
2	Aspect Ratio	16:9	
3	PDP Module	PDP60H2####, RGB Closed(Well) Type, Glass Filter(38%) Pixel Format : 1920 horiz. By 1080 ver.	
4	Operating Environment	1) Temp. : 0 ~ 40 deg 2) Humidity : 20 ~ 80 %	LGE SPEC.
5	Storage Environment	3) Temp. : -20 ~ 60 deg 4) Humidity : 10 ~ 90 %	
6	Input Voltage	100-240V~, 50/60Hz	Maker LG

(5) 32" XGA Module

No	Item	Specification	Remark
1	Display Screen Device	32 inch Wide Color Display Module	PDP
2	Aspect Ratio	16:9	
3	PDP Module	PDP32G1#####, RGB Closed(Well) Type, Glass Filter(38%) Pixel Format : 1024 horiz. By 720 ver.	
4	Operating Environment	1) Temp. : 0 ~ 40 deg 2) Humidity : 20 ~ 80 %	LGE SPEC.
5	Storage Environment	3) Temp. : -20 ~ 60 deg 4) Humidity : 10 ~ 90 %	
6	Input Voltage	100-240V~, 50/60Hz	Maker LG

√ Model General Specification

No	Item	Specification	Remark
1	Market	Austria,Belgium,Bulgaria,Coratia,Czech,Denmark,Finland ,France,Germany,Greece,Hungary,Italy,Luxembourg, Netherlands,Norway,Poland,Portugal,Rumania,Russia, Serbia,Slovenia,Spain,Sweden,Switzerland,UK,Morocco, Turkey	27 Country
2	Broadcasting system	1) PAL/SECAM BG 2) PAL/SECAM DK 3) PAL I / II 4) SECAM L/L' 5) DVB T	EU(PAL Market)
3	Receiving system	Analog : Upper Heterodyne Digital : COFDM	
4	Scart Jack(2EA)	PAL, SECAM	Scart1 Jack is Full scart and support RF-OUT(Analoge) Scart2 Jack is Half scart and support MNT-OUT
5	Video Input (1EA)	PAL, SECAM, NTSC	Side AV
6	S-Video Input (1EA)	PAL, SECAM, NTSC	Side AV
7	Component Input (1EA)	Y/Cb/Cr, Y/Pb/Pr	
8	RGB Input	RGB-PC	Analog(D-Sub 15Pin)
9	HDMI Input(4EA)	HDMI-PC HDMI-DTV	HDMI1/DVI,HDMI2,HDMI3,HDMI4
10	Audio Input (3EA)	RGB/DVI Audio, Component, AV	L/R Input
11	SPDIF Out(1EA)	SPDIF OUT	
12	USB	For SVC, S/W Download, X-Studio	Side(X-Studio Only PG60 Series)

ADJUSTMENT INSTRUCTION

1. Application Range

This spec. sheet is applied to all of the PD81A chassis manufactured at LG TV Plant all over the world.

Ex.) PD81A: 50PG6000-ZA, 42PG6000-ZA, 50PG7000-ZB, 60PG7000-ZB, 32PG6000-ZA ...

2. Specification.

- [Caution: The module keeping condition
1. The module keeping condition: The normal temperature condition (more than 15°C)
--> Immediately the line supply.
 2. The module keeping condition: 0°C
--> The module must be kept for more than 2 hours at the normal temperature.
 3. The module keeping condition: -20°C
--> The module must be kept for more than 3 hours at the normal temperature.
 4. The case of Gu-mi factory at the winter season.
--> The module must be kept for more than 5 minutes at the heating zone (40°C~45°C).

- (1) Because this is not a hot chassis, it is not necessary to use an isolation transformer. However, the use of isolation transformer will help protect test instrument.
 - (2) Adjustment must be done in the correct order.
 - (3) The adjustment must be performed in the circumstance of 25±5°C of temperature and 65±10% of relative humidity if there is no specific designation.
 - (4) The input voltage of the receiver must keep 100~240V, 50/60Hz.
 - (5) The receiver must be operated for about 5 minutes prior to the adjustment.
 - After RGB Full White in HEAT-RUN Mode, the receiver must be operated prior to the adjustment.
 - Enter into HEAT-RUN MODE
 - 1) Press the POWER ON KEY on R/C for adjustment.
 - 2) Press the ADJ KEY on R/C and enter EZ ADJUST
Select "3. Test Pattern" by using D/E (CH +/-) and press ENTER(✓)
Select "White" by using F/G (VOL +/-) and press ENTER(✓)
- Set is activated HEAT run without signal generator in this mode.
 - Single color pattern (RED / BLUE / GREEN) of HEAT RUN MODE uses to check panel.
 - Caution: If you turn on a still screen more than 20 minutes (Especially digital pattern, cross hatch pattern), an after image may occur in the black level part of the screen.

[Caution

- Using 'power on' button of the control R/C, power on TV.
- All adjustment process is executed through RS-232C.
- Do not connect external input cable.

3. S/W Auto Download Using the USB Memory Stick

[Caution

- Using 'power on' button of the control R/C, power on TV.
- USB file (EPK) version must be bigger than downloaded version of main B/D.

- (1) Insert the USB memory stick to the SET.
- (2) Using 'power on' button of the control R/C, power on TV.
- (3) S/W download process is executed automatically.

4. Auto-control Adjustment is Process

- (1) All adjustment process is executed through RS-232C.
- (2) Command send --> ADC Calibration --> Model name download --> EDID download.

(3) Auto-control adjustment protocol (RS-232C)

No	Item	CMD 1	CMD 2	Data 0	Remark
1	Ready	a	d	0 0	ready
2	ADC	a	d	1 0	ADC start
3	ADC Mode Out	a	d	9 0	
4	ADC Confirmation	a	d	9 9	
5	EDID Download	a	e	1 0 ~ 4,9	All=0 : HDMI1,2,3,4=1,2,3,4 : RGB=9
6	Check EDID Status	a	e	2 0 ~ 4,9	All=0 : HDMI1,2,3,4=1,2,3,4 : RGB=9
7	Download Mode In	a	e	0 0	Transmitting adjustment mode In instruction, operate adjustment command.
8	Define model name	a	e	5 1 ~ 9	Model define index(Data0) are listed at next table.
9	Download Mode Out	a	e	9 0	
10	Adjustment Confirmation	a	e	9 9	EDID data existence check in SET assembly

(4) Defined model name protocol (RS-232C)

CMD 1	CMD 2	Data 0	Remark
a	e	5 1	50PG4000-ZA
a	e	5 2	50PG6000-ZA
a	e	5 3	42PG6000-ZA
a	e	5 4	32PG6000-ZA
a	e	5 5	50PG6010-ZE
a	e	5 6	42PG6010-ZE
a	e	5 7	32PG6010-ZE
a	e	5 8	50PG7000-ZB
a	e	5 9	60PG7000-ZB

5. Manual Model Name Download

- (1) Press ADJ key on R/C for model name D/L
- (2) Select “. Model Option” and press ENTER(√)
- (3) Insert Option value by a number key
- (4) Press the ENTER(√)

Model Name	Model Option Value
50PG6000-ZA	36000000
50PG6010-ZE	36001004
42PG6000-ZA	56000000
42PG6010-ZE	56001004
32PG6000-ZA	76000000
32PG6010-ZE	76001004
50PG7000-ZB	37000001
60PG7000-ZB	17000001
50PG4000-ZA	34000000

6. Manual ADC Adjustment

[Caution

- Do not connect external input cable
- Adjustment result is applied to SET On/Off later.

RF Input	AV / Component / RGB input
NO SIGNAL or White noise	NO SIGNAL

[Adjustment is done using internal ADC, so input signal is not necessary.

- (1) Press ADJ key on R/C for adjustment.
- (2) Select “2. ADC calibration” by using D/E (CH +/-) and press ENTER(√).
- (3) Select “Start” by using F/G (VOL +/-) and press ENTER(√).
- (4) ADC adjustment is executed automatically.

7. Manual EDID Download

- (1) Press the ADJ KEY on R/C and enter EZ ADJUST.
- (2) Select “5. EDID D/L” by using D/E (CH +/-) and press ENTER(√).
- (3) Select “Start” and press ENTER(√).
- (4) EDID download is executed automatically.
- (5) Press EXIT key on R/C.

8. EDID Data

(1) HDMI 1 (256 bytes)

	0	1	2	3	4	5	6	7	8	9	A	B	C	D	E	F
00	00	FF	FF	FF	FF	FF	FF	00	1E	5D						
10			01	03	80	46	27	78	EA	09	80	A3	57	49	9C	25
20	11	49	4B	A1	08	00	01	40	45	40	51	40	81	80	90	40
30	A9	40	01	C0	01	01	1A	36	80	A0	70	38	1F	40	30	20
40	35	00	28	26	32	00	00	1A	1B	21	50	A0	51	00	1E	30
50	48	88	35	00	9C	86	21	00	00	1C	00	00	00	FD	00	39
60	4B	1F	54	12	00	3A	20	20	20	20	20	20				
70													0A	20	01	

	0	1	2	3	4	5	6	7	8	9	A	B	C	D	E	F
00	00	03	21	F1	4E	81	02	03	15	12	13	04	14	05	20	21
10	22	1F	10	23	15	07	50	83	01	50	00	85	03	0C	00	10
20	00	01	1D	00	80	51	00	1C	20	40	80	25	00	9C	88	21
30	00	00	1E	9C	3A	00	3A	20	20	10	10	3E	86	00	13	
40	8E	21	00	00	18	02	3A	80	18	71	38	20	40	58	2C	45
50	00	06	44	21	00	00	1E	01	1D	80	18	71	1C	16	20	58
60	2C	25	00	C4	8E	21	00	00	9E	4E	1F	00	80	51	00	1E
70	30	40	90	37	00	9C	88	21	00	00	18	00	00	18	00	

(2) RGB (128 bytes)

	0	1	2	3	4	5	6	7	8	9	A	B	C	D	E	F
00	00	FF	FF	FF	FF	FF	00	1E	5D							
10			01	03	80	46	27	78	EA	09	80	A3	57	49	9C	25
20	11	49	4B	A1	08	00	01	40	45	40	51	40	81	80	90	40
30	01	C0	01	01	01	1A	36	80	A0	70	38	1F	40	30	20	
40	35	00	28	26	32	00	00	1A	1B	2F	78	80	51	1A	25	40
50	58	98	14	00	28	26	32	00	00	1A	00	00	00	FD	00	39
60	4B	1F	54	12	00	3A	20	20	20	20	20	20				
70													20	20	00	

=> Detail EDID Options are below(㉠, ㉡, ㉢, ㉣, ㉤, ㉥)

1. ㉠ -> Product ID

MODEL	EDID MODEL	PRODUCT_ID	FUNCTION
42PG6000-ZA	42PG6000-ZA	40239(9D2F)	Analog
42PG6000-ZA	42PG6000-ZA	40240(9D30)	Digital
50PG6000-ZA	50PG6000-ZA	50097(C3B1)	Analog
50PG6000-ZA	50PG6000-ZA	50098(C3B2)	Digital
32PG6000-ZA	32PG6000-ZA	30225(7611)	Analog
32PG6000-ZA	32PG6000-ZA	30226(7612)	Digital
32PG6010-ZE	32PG6010-ZE	30227(7613)	Analog
32PG6010-ZE	32PG6010-ZE	30228(7614)	Digital
42PG6010-ZE	42PG6010-ZE	40269(9D4D)	Analog
42PG6010-ZE	42PG6010-ZE	40270(9D4E)	Digital
50PG6010-ZE	50PG6010-ZE	50138(C3DA)	Analog
50PG6010-ZE	50PG6010-ZE	50139(C3DB)	Digital
50PG7000-ZB	50PG7000-ZB	50150(C3E6)	Analog
50PG7000-ZB	50PG7000-ZB	50151(C3E7)	Digital
60PG7000-ZB	60PG7000-ZB	50148(C3E4)	Analog
60PG7000-ZB	60PG7000-ZB	50149(C3E5)	Digital
50PG4000-ZA	50PG4000-ZA	50178(C402)	Analog
50PG4000-ZA	50PG4000-ZA	50179(C403)	Digital

2. ㉡ -> Serial No : Controlled on production line

3. ㉢ -> Month, Year : Controlled on production line

4. ㉔ -> Model Name

MODEL NAME	MODEL NAME (HEX)
50PG6000	000000FC0035305047363030300A20202020
42PG6000	000000FC0034325047363030300A20202020
32PG6000	000000FC0033325047363030300A20202020
50PG6010	000000FC0035305047363031300A20202020
42PG6010	000000FC0034325047363031300A20202020
32PG6010	000000FC0033325047363031300A20202020
50PG7000	000000FC0035305047373030300A20202020
60PG7000	000000FC0036305047373030300A20202020
50PG4000	000000FC0035305047373030300A20202020

5. ㉔ -> Checksum : Changeable by total EDID data.

9. PCMCIA CARD Checking Method

You must adjust DTV 29 Channel and insert PCMCIA CARD to socket.

- (1) If PCMCIA CARD works normally, normal signals display on screen.
But it works abnormally, "No CA module" words display on screen.

[Caution: Set up "RF mode" before launching products.

Caution: Each PCB assembly must be checked by check JIG set. (Because power PCB Assembly damages to PDP Module, especially be careful)

Caution: Set up "RF mode(noise)" before voltage adjustment.
- Test equipment: D.M.M 1EA
- Connection Diagram for Measuring: refer to fig.1, fig 2, fig 3. fig 4

10. 50" POWER PCB Ass'y Voltage Adjustment (Va, Vs voltage Adjustment)

10-1. Model name: 50PG6000, 50PG6010

10-2. Adjustment Method

- (1) 50" Va Adjustment (refer fig. 1)
 - 1) After receiving 100% Full White Pattern, HEAT RUN.
 - 2) Connect + terminal of D. M. M. to Va pin of P811, connect -terminal to GND pin of P811.
 - 3) After turning VR901, voltage of D.M.M adjustment as same as Va voltage which on label of panel right/top (deviation; $\pm 0.5V$)
- (2) 50" Vs Adjustment (refer fig. 1)
 - 1) Connect + terminal of D. M. M. to Vs pin of P811, connect -terminal to GND pin of P811.
 - 2) After turning VR951, voltage of D.M.M adjustment as same as Vs voltage which on label of panel right/top (deviation ; $\pm 0.5V$)

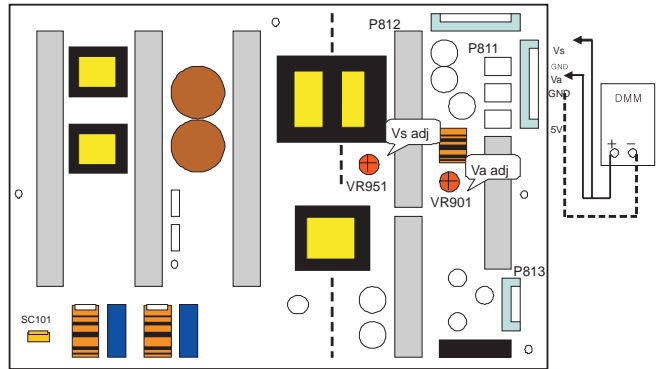

(Fig. 1) 50inch Power PCB Assy Voltage Adjustment

11. 42" POWER PCB Ass'y Voltage Adjustment (Va, Vs voltage Adjustment)

11-1. Model name: 42PG6000, 42PG6010

11-2. Adjustment Method

- (1) 42" Va Adjustment (refer fig. 2)
 - 1) After receiving 100% Full White Pattern, HEAT RUN.
 - 2) Connect + terminal of D. M. M. to Va pin of P811, connect -terminal to GND pin of P811.
 - 3) After turning VR901, voltage of D.M.M adjustment as same as Va voltage which on label of panel right/top (deviation; $\pm 0.5V$)
- (2) 42" Vs Adjustment (refer fig. 2)
 - 1) Connect + terminal of D. M. M. to Vs pin of P811, connect -terminal to GND pin of P811.
 - 2) After turning VR951, voltage of D.M.M adjustment as same as Vs voltage which on label of panel right/top (deviation ; $\pm 0.5V$)

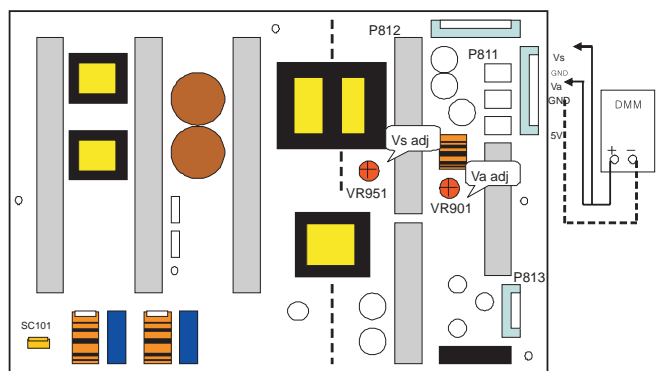

(Fig. 2) 42inch Power PCB Assy Voltage Adjustment

12. 60"(FHD), 50"(FHD) POWER PCB Ass'y Voltage Adjustment (Va, Vs voltage Adjustment)

12-1. Model name: 50PG7000, 60PG7000, 50PG4000

12-2. Adjustment Method

- (1) 60" FHD Va Adjustment (refer fig. 3)
 - 1) After receiving 100% Full White Pattern, HEAT RUN.
 - 2) Connect + terminal of D. M..M. to Va pin of P11, connect -terminal to GND pin of P11.
 - 3) After turning VR901, voltage of D.M.M adjustment as same as Va voltage which on label of panel right/top (deviation; $\pm 0.5V$)
- (2) 60" FHD Vs Adjustment (refer fig. 3)
 - 1) Connect + terminal of D. M..M. to Vs pin of P11, connect -terminal to GND pin of P11.
 - 2) After turning VR951, voltage of D.M.M adjustment as same as Vs voltage which on label of panel right/top (deviation ; $\pm 0.5V$)

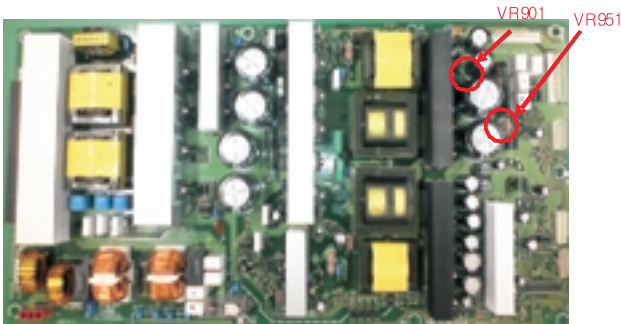

(Fig. 3) 60inch FHD Power PCB Assy Voltage Adjustment

13. 32"(XGA) POWER PCB Ass'y Voltage Adjustment (Va, Vs voltage Adjustment)

13-1. Model name: 32PG6000, 32PG6010

13-2. Adjustment Method

- (1) 32" Va Adjustment (refer fig. 4)
 - 1) After receiving 100% Full White Pattern, HEAT RUN.
 - 2) Connect + terminal of D. M..M. to Va pin of P811, connect -terminal to GND pin of P811.
 - 3) After turning VR901, voltage of D.M.M adjustment as same as Va voltage which on label of panel right/top (deviation; $\pm 0.5V$)
- (2) 32" Vs Adjustment (refer fig. 4)
 - 1) Connect + terminal of D. M..M. to Vs pin of P811, connect -terminal to GND pin of P811.
 - 2) After turning VR951, voltage of D.M.M adjustment as same as Vs voltage which on label of panel right/top (deviation ; $\pm 0.5V$)

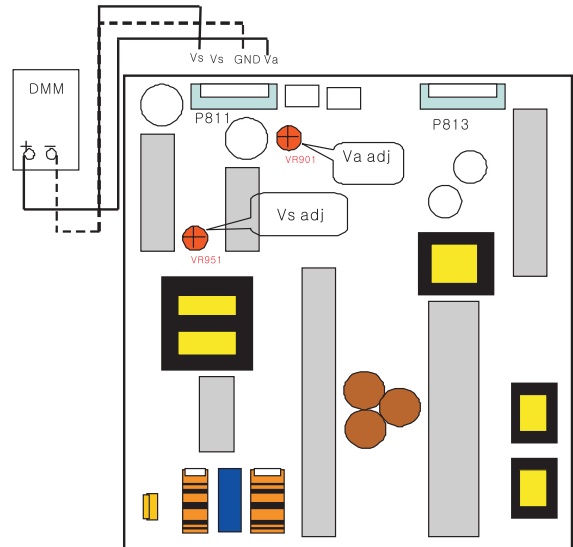

(Fig. 4) 32inch Power PCB Assy Voltage Adjustment

- Before adjusting White-balance , the AV ADC should be done.
- If ADC status were "NG", Need to ADC adjustment.

14. Adjustment of White Balance

Caution: Press the POWER ON KEY on R/C before W/B adjustment.

14-1. Test Equipment

- Color Analyzer (CS-1000, CA-100+(CH.10), CA-210(CH.10))

[Please adjust CA-100+ / CA-210 by CS-1000 before measuring

--> You should use Channel 10 which is Matrix compensated (White, Red, Green, Blue revised) by CS-1000 and adjust in accordance with White balance adjustment coordinate.

- o Color temperature standards according to CSM and Module

CSM	PLASMA
Cool	11000K
Medium	9300K
Warm	6500K

- o Change target luminance and range of the Auto adjustment W/B equipment.

Target luminance	65
Range	20

o White balance adjustment coordinate and color temperature

Cool	CS-1000	CA-100+ (CH.10)	CA-210 (CH.10)
x	0.276	0.276±0.002	0.276±0.002
y	0.283	0.283±0.002	0.283±0.002
Δuv	0.000	0.000	0.000
Medium	CS-1000	CA-100+ (CH.10)	CA-210 (CH.10)
x	0.285	0.285±0.002	0.285±0.002
y	0.293	0.293±0.002	0.293±0.002
Δuv	0.000	0.000	0.000
Warm	CS-1000	CA-100+ (CH.10)	CA-210 (CH.10)
x	0.313	0.313±0.002	0.313±0.002
y	0.329	0.329±0.002	0.329±0.002
Δuv	0.003	0.003	0.003

PC (for communication through RS-232C) ==> UART Baud rate : 115200 bps

14-2. Connecting Picture of the Measuring Instrument (On Automatic control)

Inside PATTERN is used when W/B is controlled. Connect to auto controller or push control R/C INSTART → Enter the mode of White-Balance, the pattern will come out.

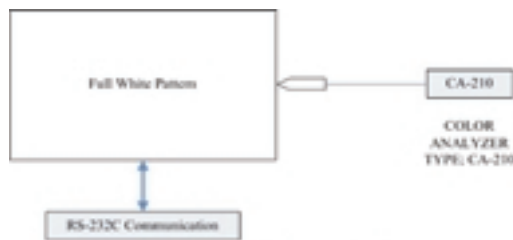

[Fig.5] connecting picture (On Automatic Control)

14-3. Auto-control Interface and Directions

- Adjust in the place where the influx of light like floodlight around is blocked. (illumination is less than 10ux).
- In case of PDP: Measure and adjust after sticking the Color Analyzer (CA-100+, CA210) to the side of the module.

In case of LCD: Adhere closely the Color Analyzer (CA210) to the module less than 10cm distance, keep it with the surface of the Module and Color Analyzer's Prove vertically.(80~100°).

- Aging time
 - After aging start, keep the power on (no suspension of power supply) and heat-run over 5 minutes.
 - In case of PDP, keep white pattern using inside pattern.
 - In case of LCD, using 'no signal' or 'full white pattern' or the others, check the back light on.

o Auto Adjustment Map(RS-232C)

	RS-232C COMMAND [CMD ID DATA]			Min	CENTER (DEFAULT)			MAX
	Cool	Med	Warm		Cool	Med	Warm	
R Gain	jd	Ja	jd	00	192	192	192	255
G Gain	jh	Jb	je	00	192	192	192	255
B Gain	ji	Jc	jf	00	192	192	192	255
42G1	R Cut				65	65	62	128
	G Cut				56	56	53	128
	B Cut				71	70	76	128
50G1	R Cut				62	63	66	128
	G Cut				58	57	62	128
	B Cut				71	71	64	128
32G1	R Cut				64	64	64	128
	G Cut				64	64	64	128
	B Cut				64	64	64	128
50H2 60H2	R Cut				64	64	64	128
	G Cut				64	64	64	128
	B Cut				64	64	64	128

14-4. Manual White Balance

- Zero Calibrate CA-100+ / CA-210, and when controlling, stick the sensor to the center of PDP module surface.
- Press the ADJ KEY on R/C and enter EZ ASJUST Select "2. White Balance" and press G (VOL +) Set test-pattern on and display inside pattern.
- Control is carried out on three color temperatures, COOL, MEDIUM, WARM. (Control is carried out three times)

- <Temperature: COOL>
- R-Cut/ G-Cut / B-Cut is set to 64
 - Control R-Gain and G-Gain.
 - Each gain is limited to 192

- <Temperature: MEDIUM>
- R-Cut/ G-Cut / B-Cut is set to 64
 - Control R-Gain and G-Gain.
 - Each gain is limited to 192

- <Temperature: WARM>
- R-Cut/ G-Cut / B-Cut is set to 64
 - Control G-Gain and B-Gain.
 - Each gain is limited to 192

TROUBLE SHOOTING GUIDE

1. Power Board

1-1. The whole flowchart which it follows in voltage output state

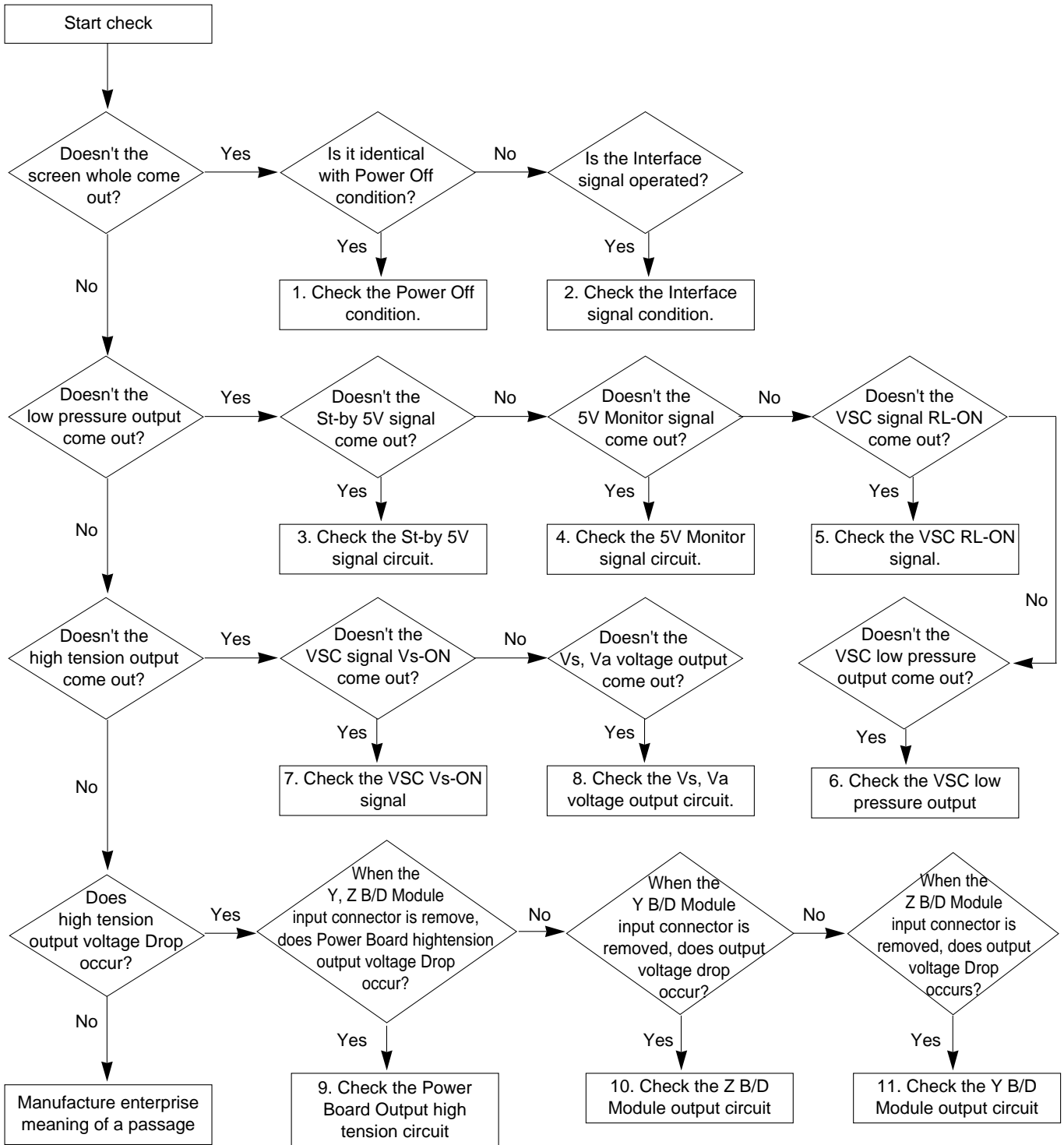

1-2. Power Board Structure

(1) Pin Layout

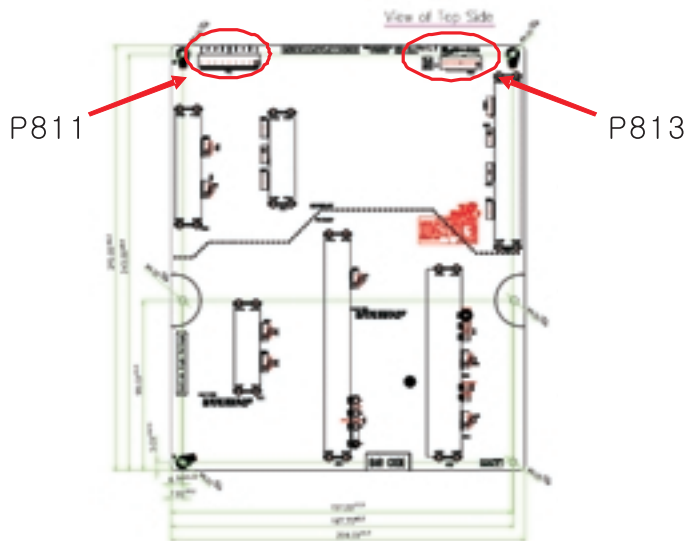

(2) Pin Spec

PSU ↔ PDP Module

	32inch
	P811
1	Vs
2	Vs
3	NC
4	GND
5	GND
6	GND
7	Va
8	GND
9	M5V
Wafer	YW396-9V

PSU ↔ VSC Board

P813			
1	16.5V	2	16.5V
3	GND	4	GND
5	12V	6	12V
7	GND	8	GND
9	5V	10	5V
11	5V	12	5V
13	GND	14	GND
15	GND	16	GND
17	5V DET	18	AC DET
19	RL-ON	20	Vs-ON
21	M5V-ON	22	AUTO_GND
Wafer	SMW200-22C		

2. No Power

(1) Symptom

- 1) Doesn't minute discharge at module.
- 2) Non does not come in into the front LED.



(2) Check following

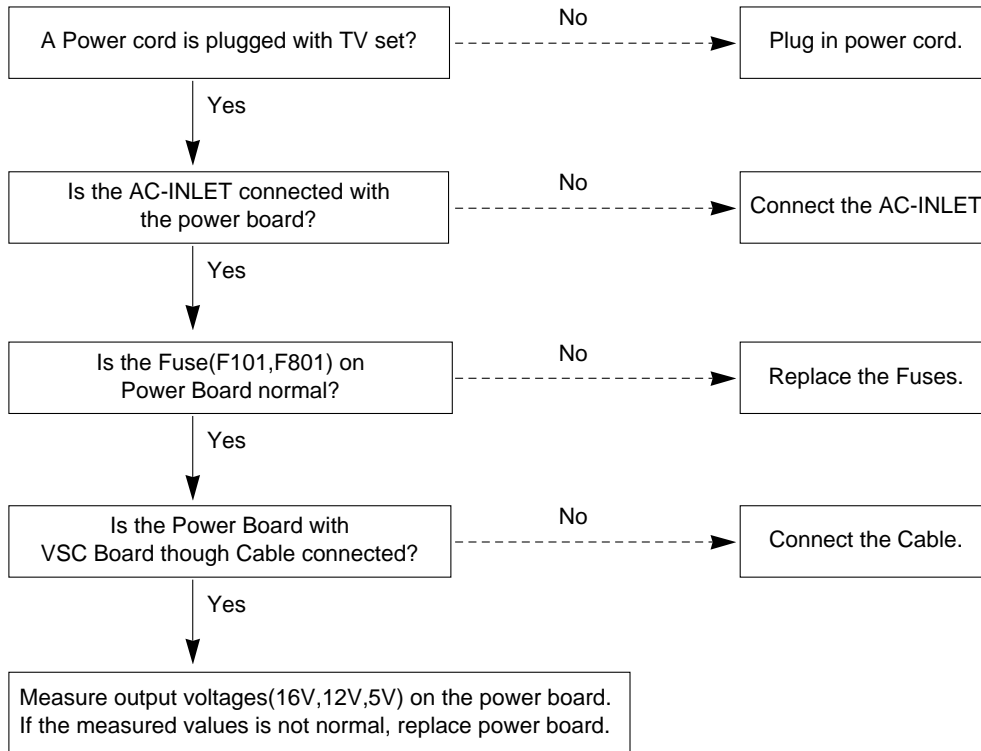

3. Protect Mode

(1) Symptom

- 1) After once shining, it does not discharge minutely from module.
- 2) The Relay falls.(The sound is audible "click")
- 3) It is converted with the color where the front LED is red from green.

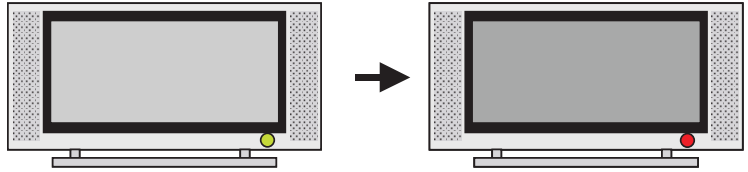

(2) Check following

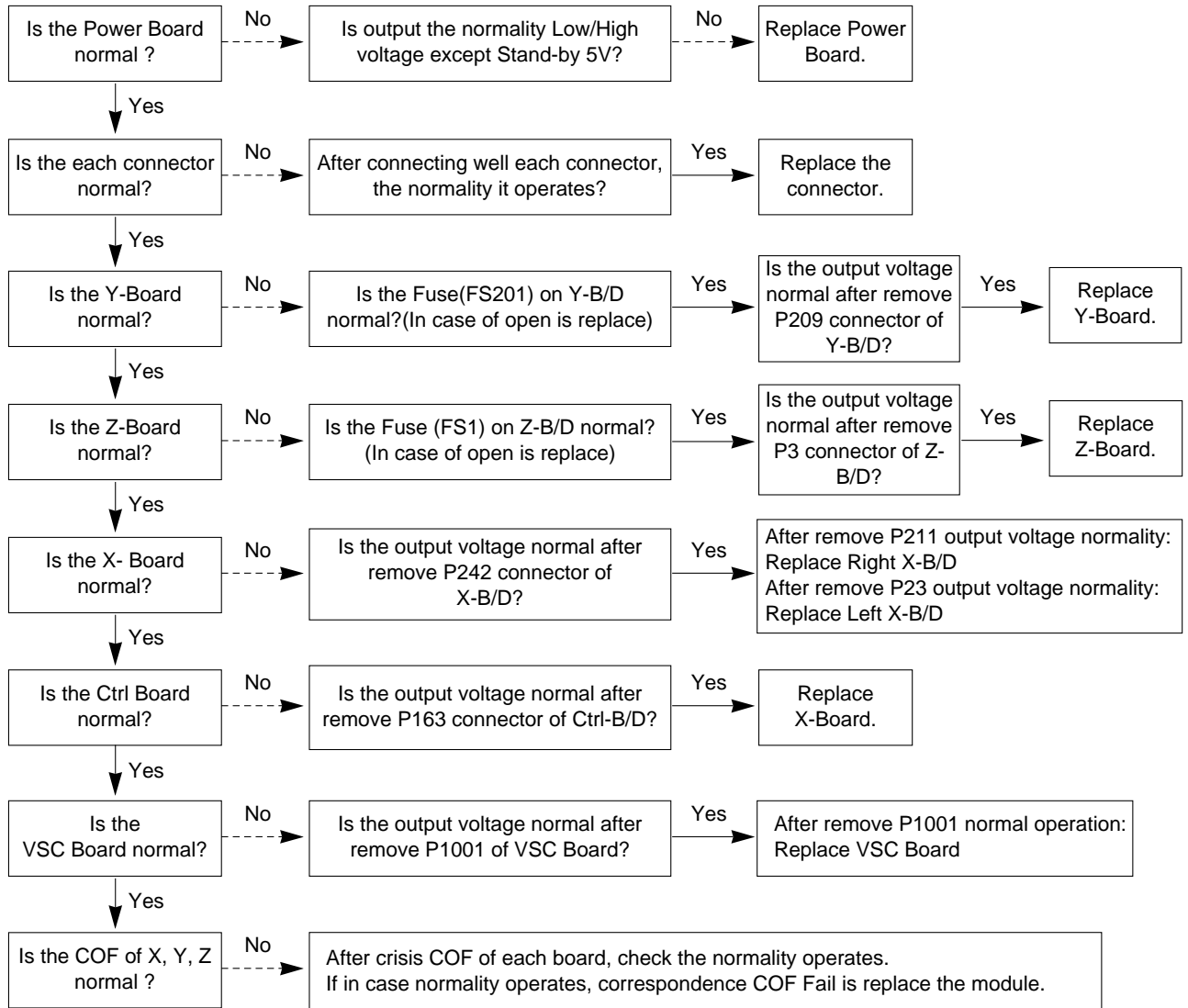

4. No Raster

(1) Symptom

- 1) No OSD and image occur at screen.
- 2) It maintains the condition where the front LED is green.



(2) Check the followings

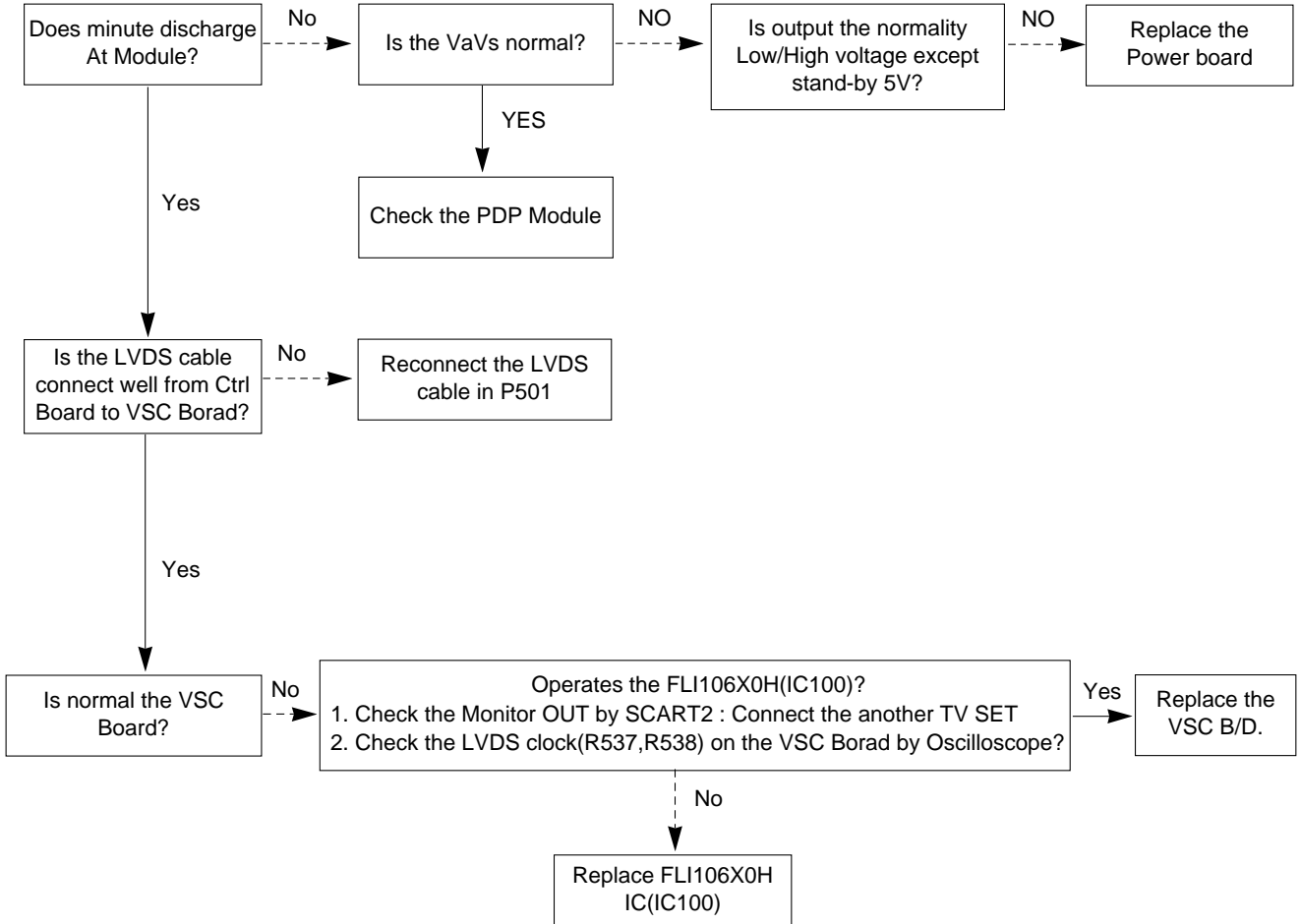

5. In case of occurring strange screen into specific mode

5-1. In case the OSD does not displayed

(1) Symptom

- 1) LED is green.
- 2) The minute discharged continuously becomes Accomplished from module.

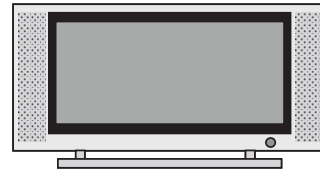

(2) Check following

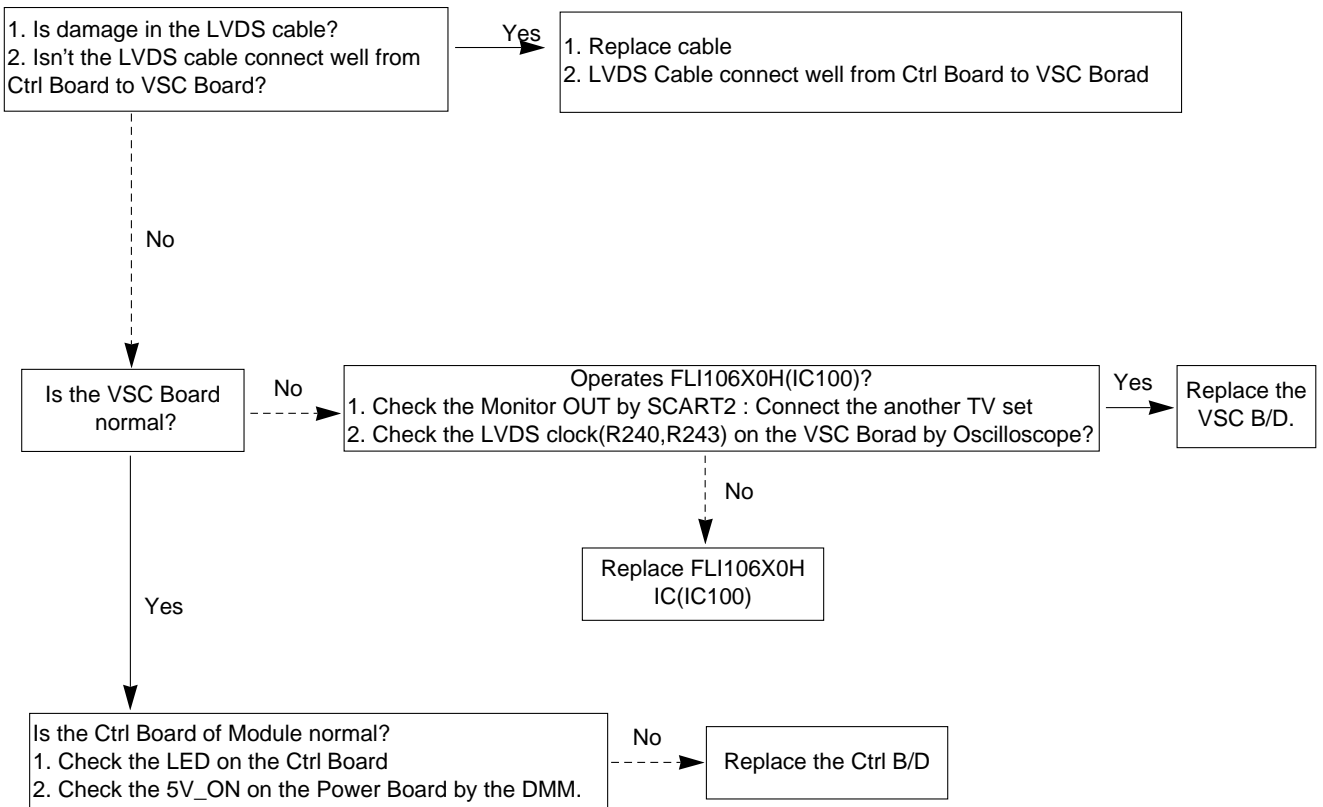

5-2. In case of does't display the screen into specific mode

(1) Symptom

- The screen does not become the display from specific input mode (RF, AV, Component, RGB, DVI).

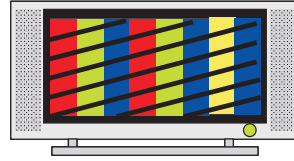

(2) Check following

- Check the all input mode should become normality display.

(3) In case of becomes unusual display from RF mode

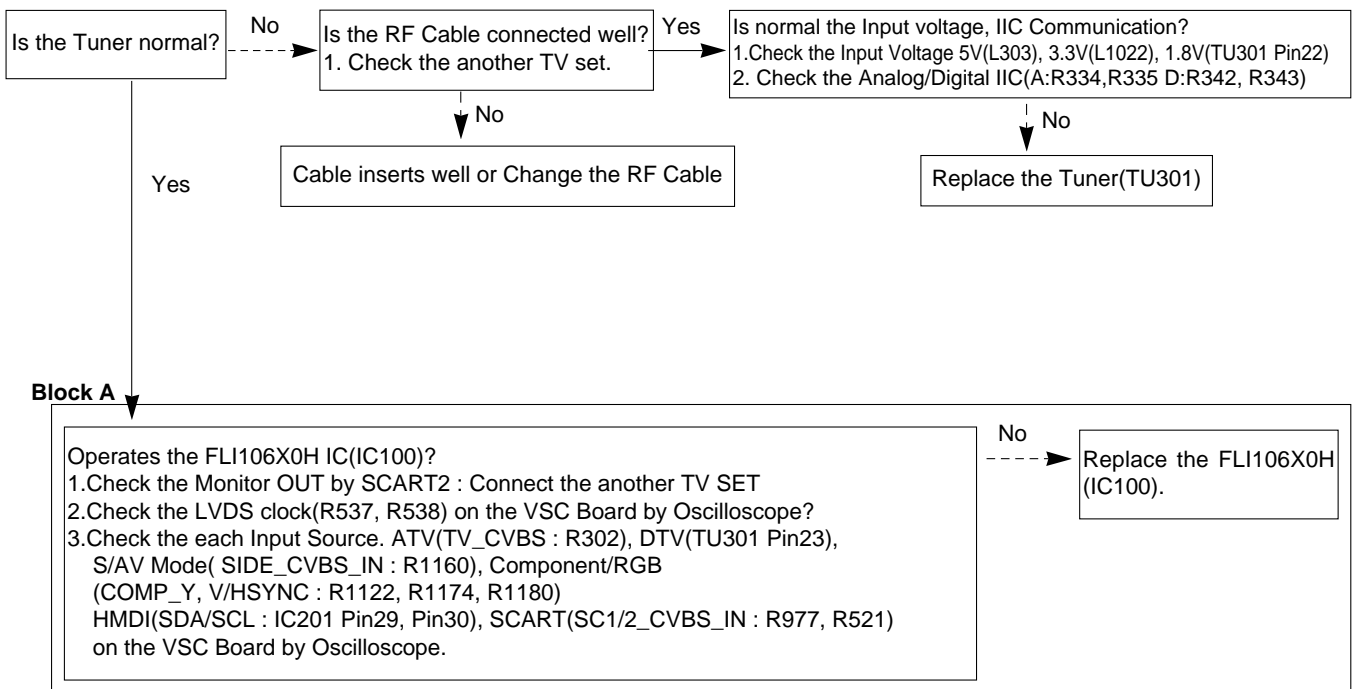

(4) In the case of becomes unusual display from side S-video/AV mode

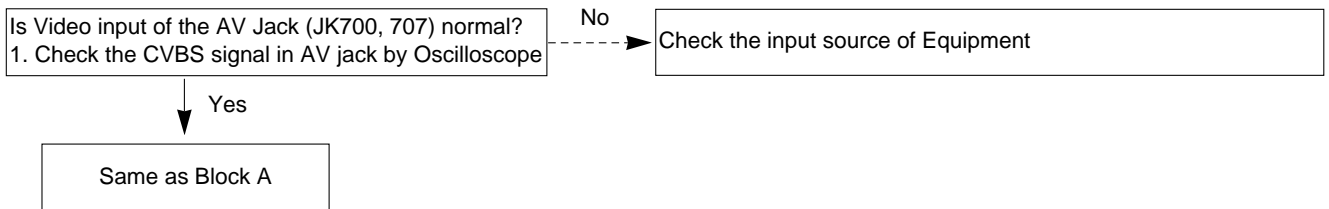

(5) In the case of becomes unusual display from Component, RGB mode

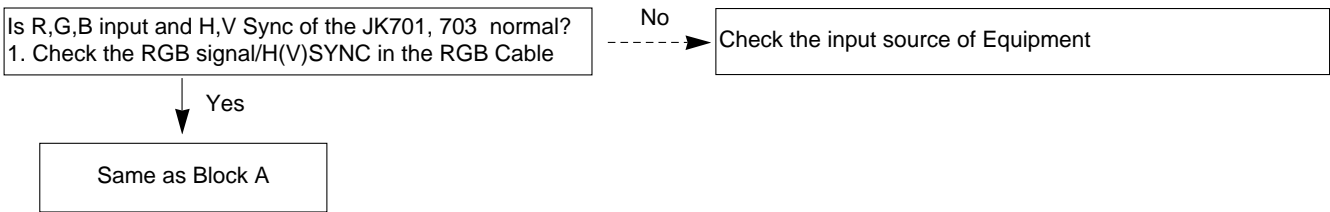

(6) In the case of becomes unusual display from HDMI mode

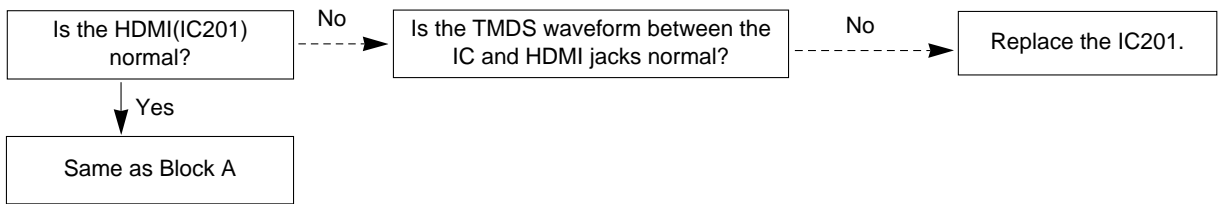

(7) In the case of becomes unusual display from SCART mode

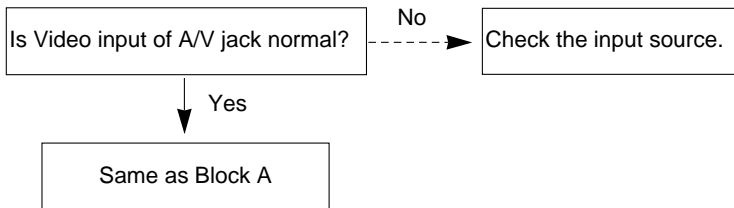

6. In case of no sound

(1) Symptom

- 1) LED is Green.
- 2) Screen display but sound is not output.



(2) Check following

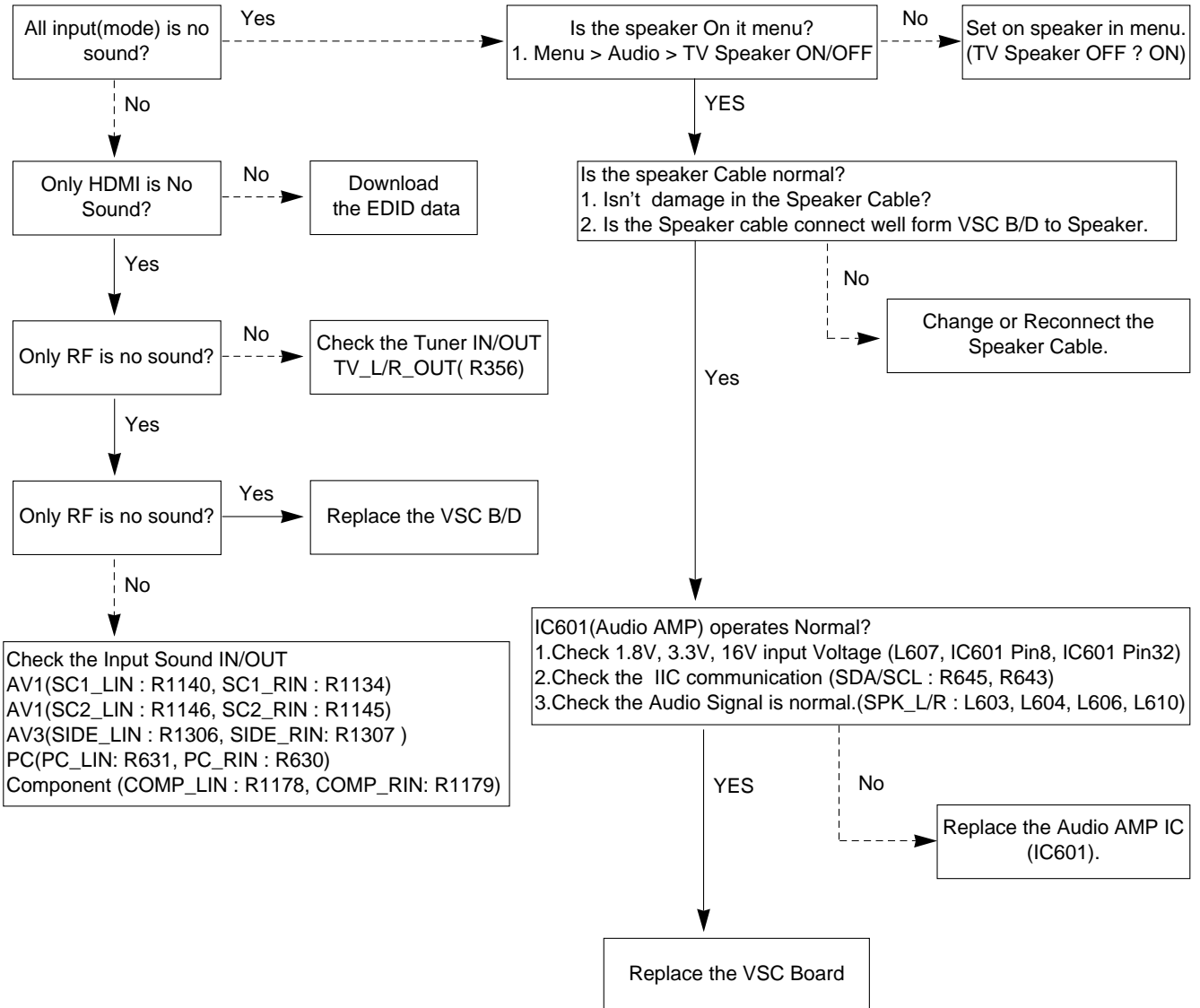

BLOCK DIAGRAM

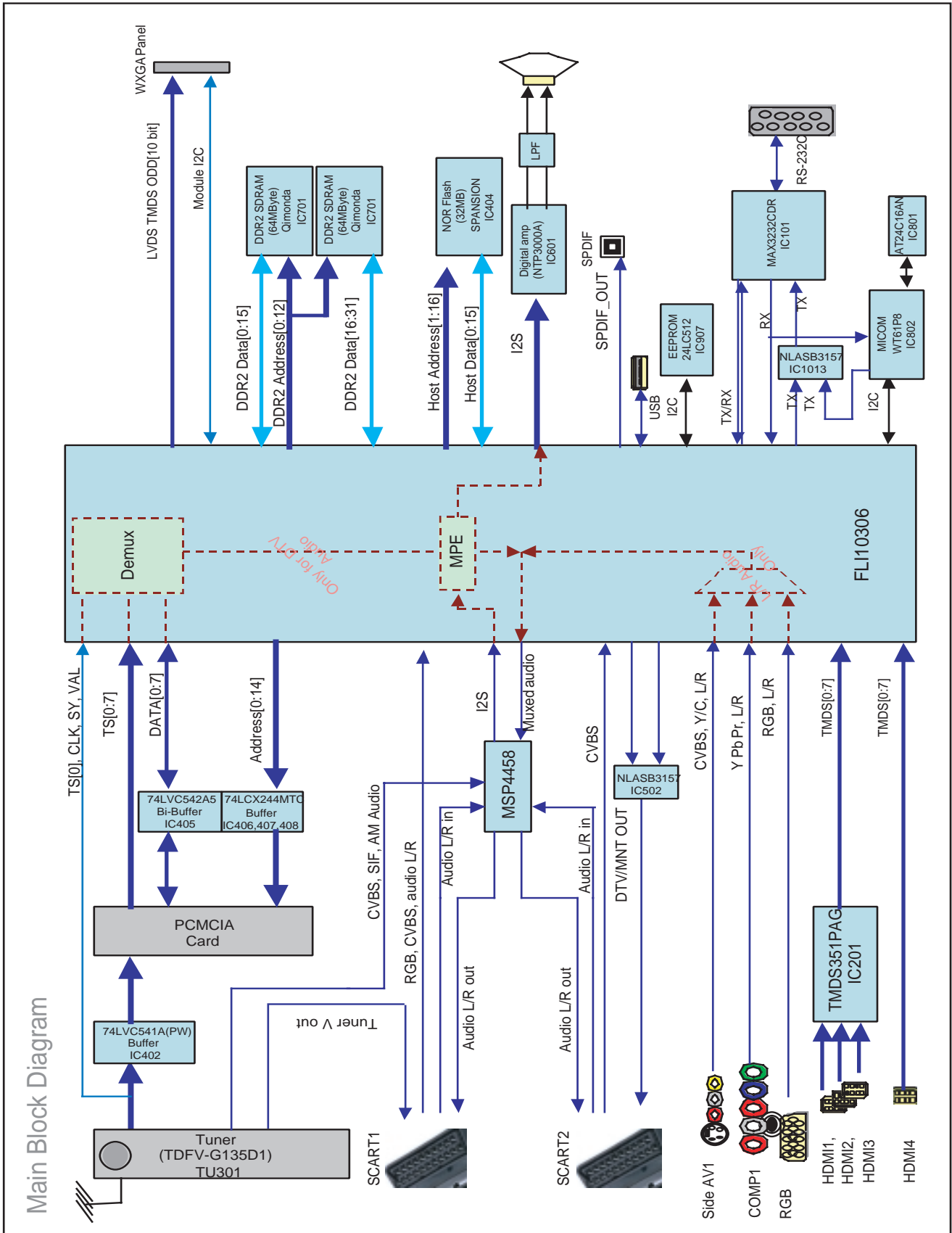

SCART 1	SCART 2
1:Audio R out (TV)	1:Audio R out (DTV)
2:audio R in	2:audio R in
3:audio L out (TV)	3:audio L out (DTV)
4:audio GND	4:audio GND
5:blue GND	5:GND
6:audio L in	6:audio L in
7:Blue	7:NC
8:SCART ID	8:function select
9:green GND	9: NC
10:data 2 (NC)	10:data 2 (NC)
11:Green	11:NC
12:data 1 (NC)	12:data1 (NC)
13: Link (red GND)	13: Link
14:data GND (NC)	14:data GND (NC)
15:Red	15: NC
16:SCART FB	16: NC
17:video GND	17:video GND
18:RGB Control GND	18:GND
19:CVBS out (TV out)	19:CVBS out (DTV out)
20:CVBS in	20:CVBS in
21:safety GND	21:safety GND
22:GND	22:GND
23:GND	23:GND

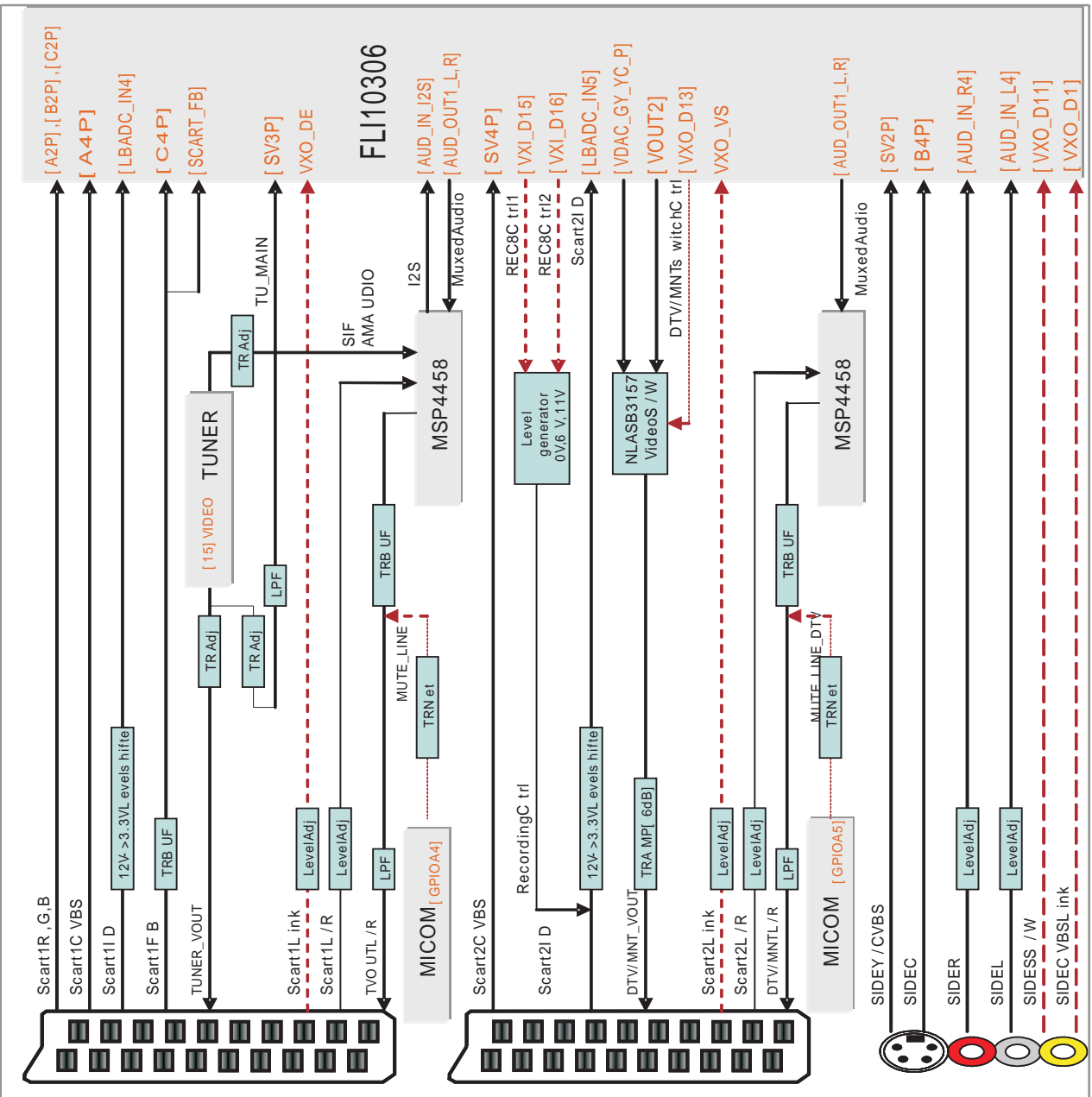

BlockDiagram (Component & RGB & HDMI)

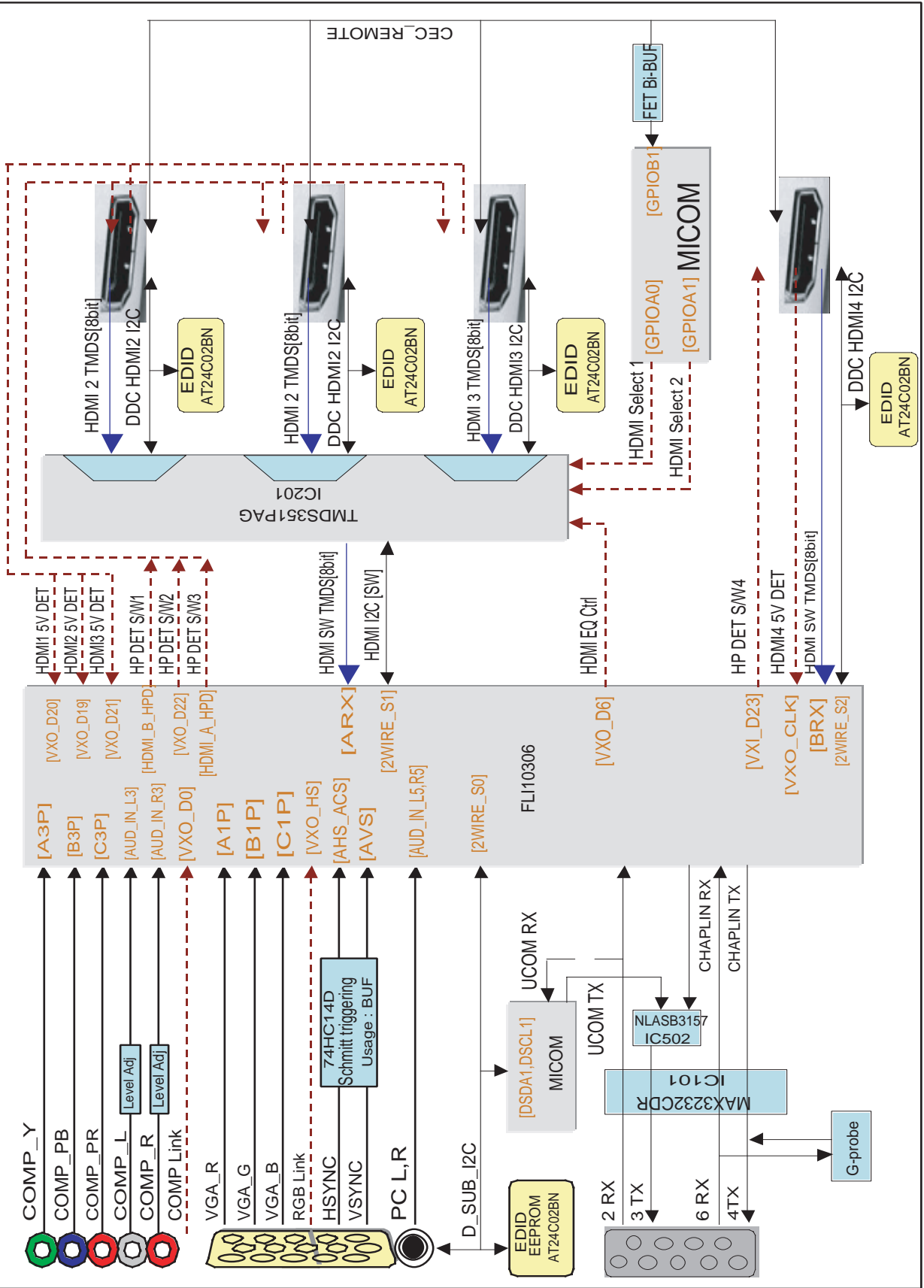

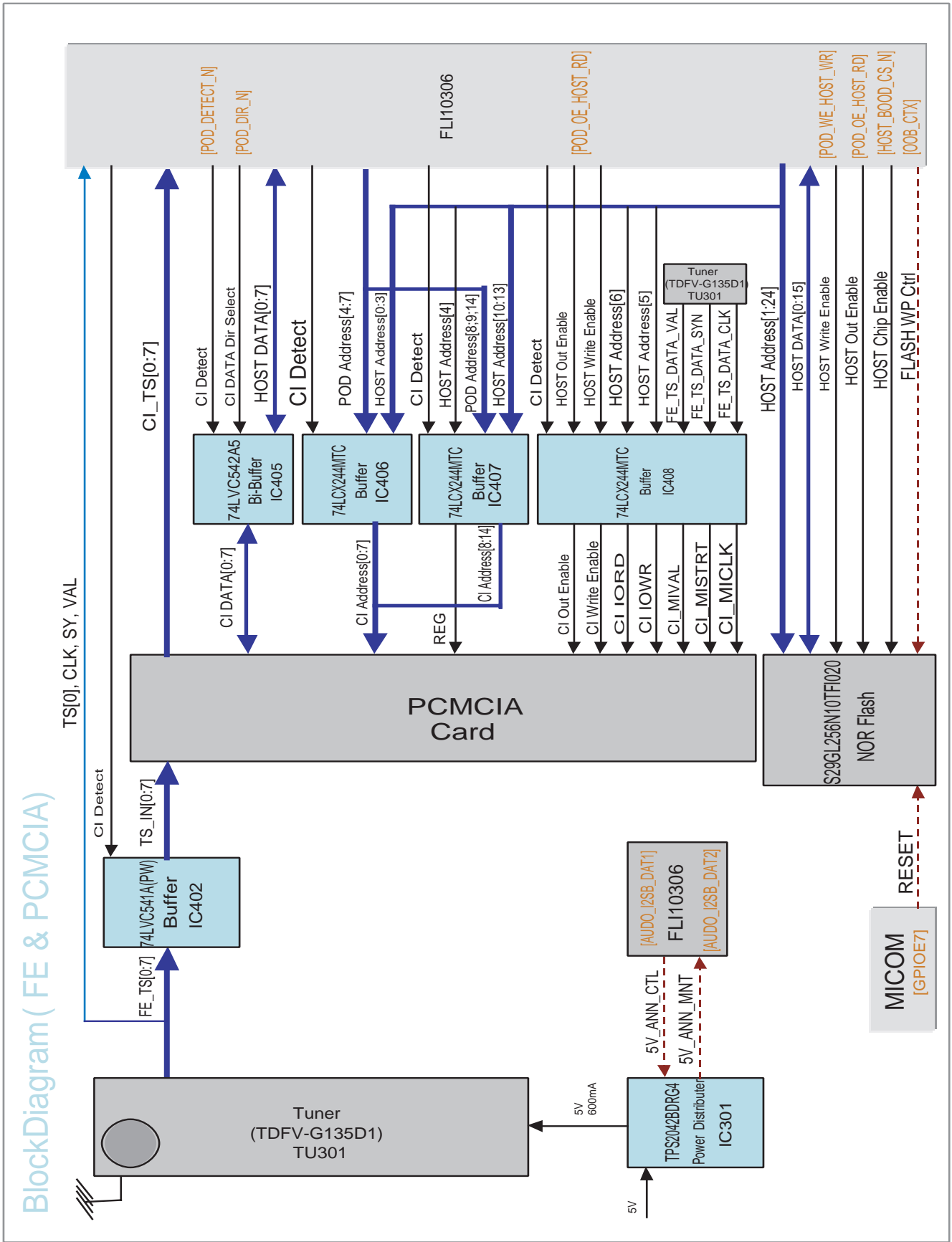

BlockDiagram(Audio & etc)

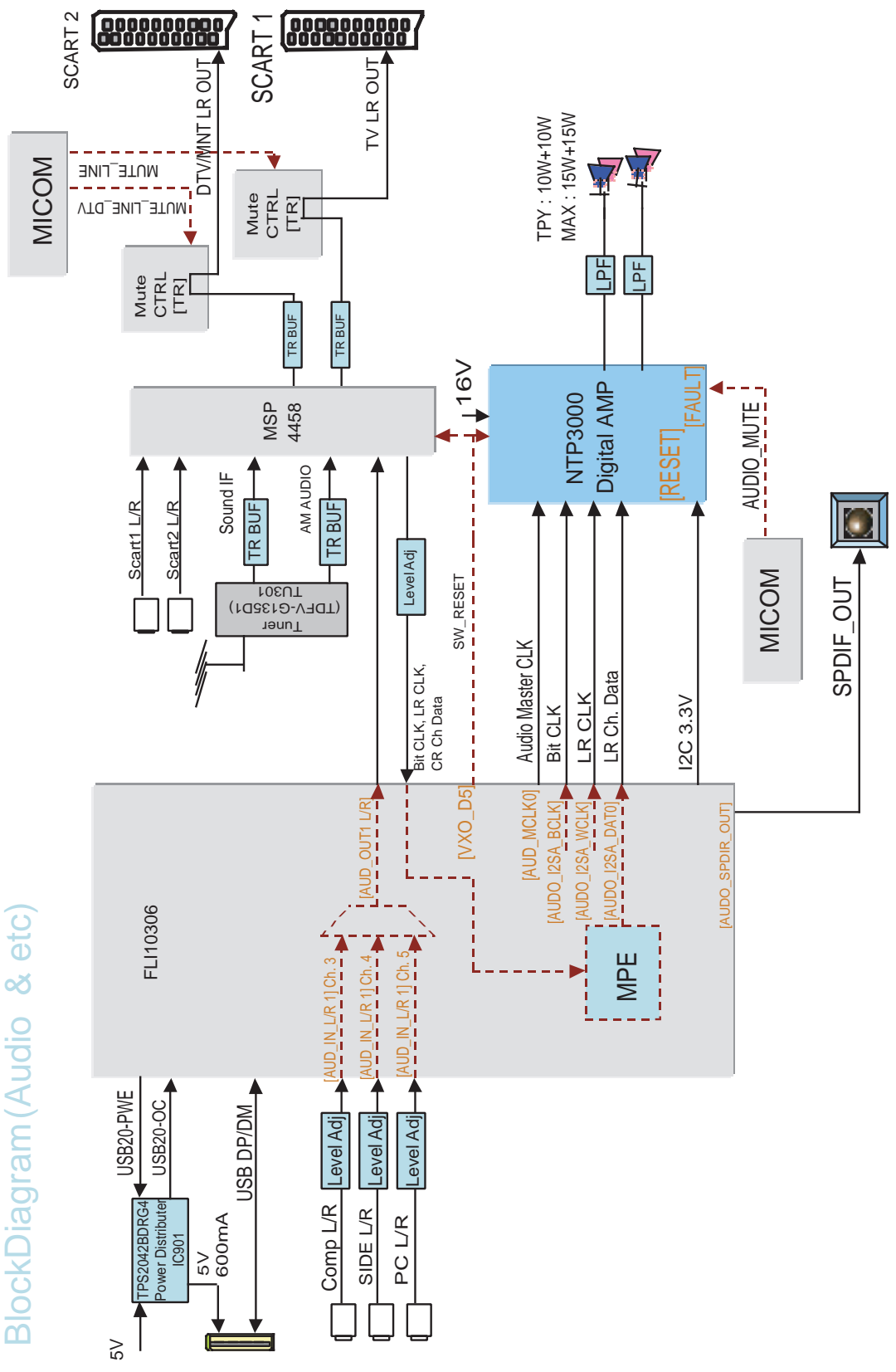

BlockDiagram (Reset)

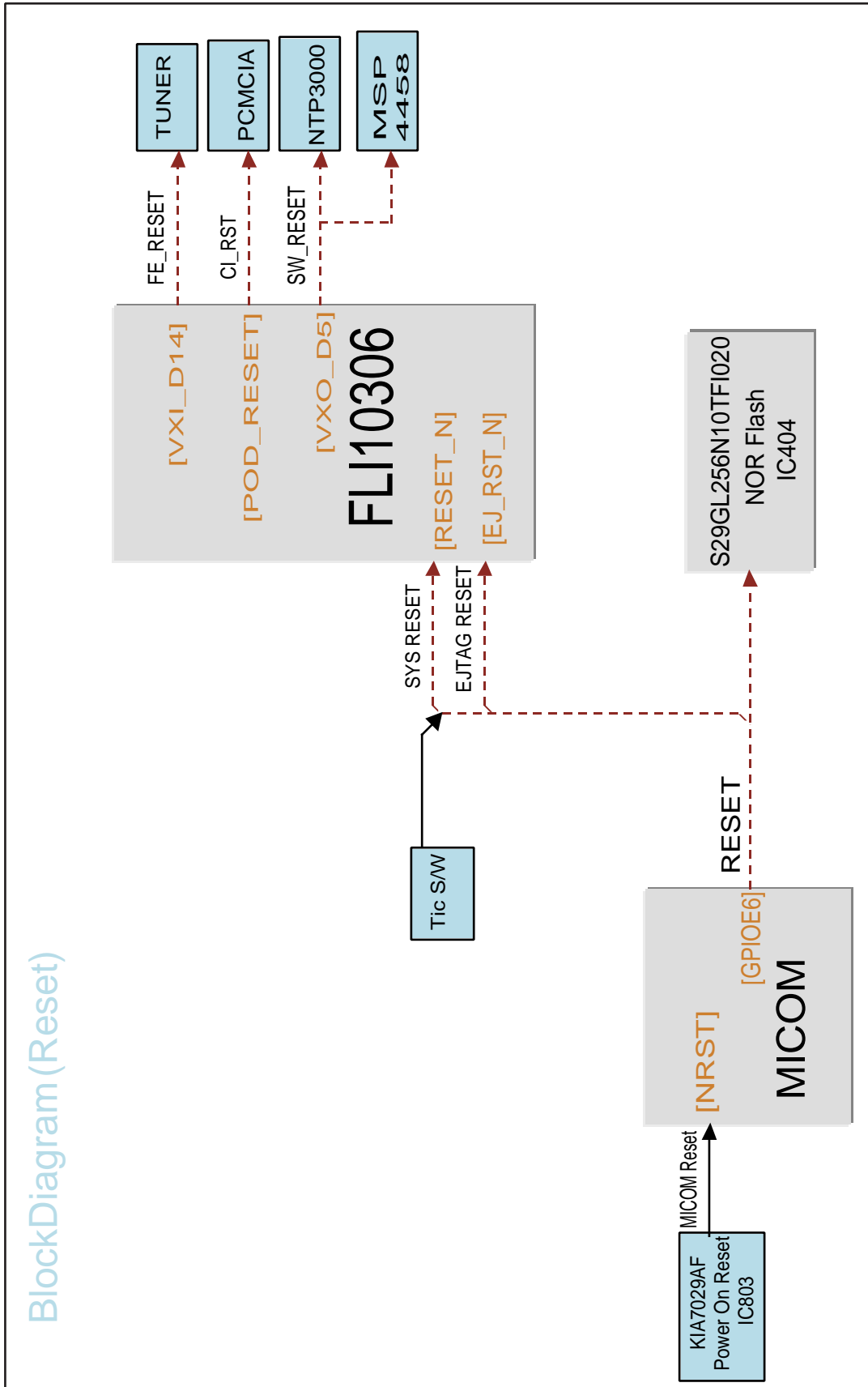

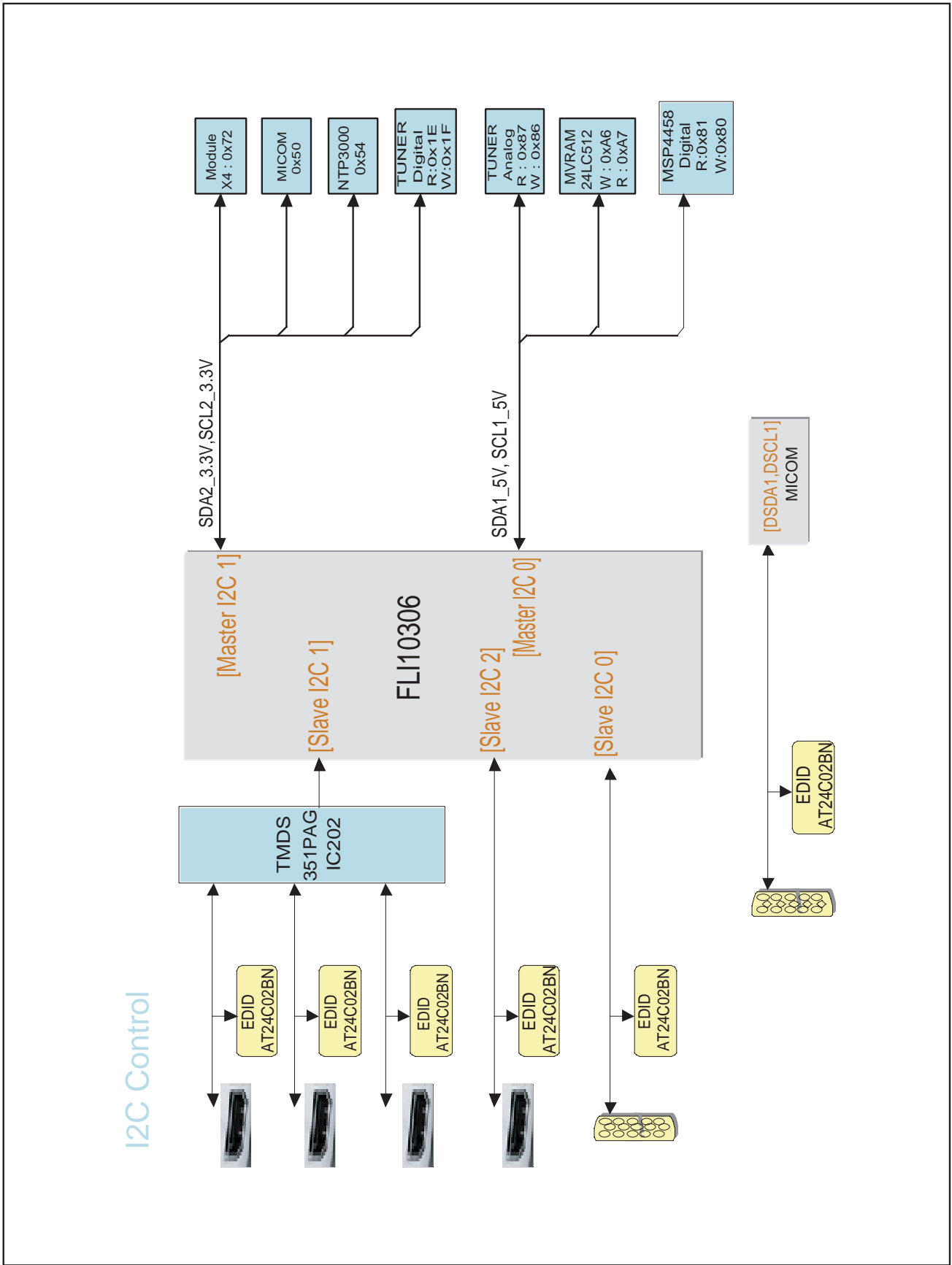

Power Voltage BlockDiagram

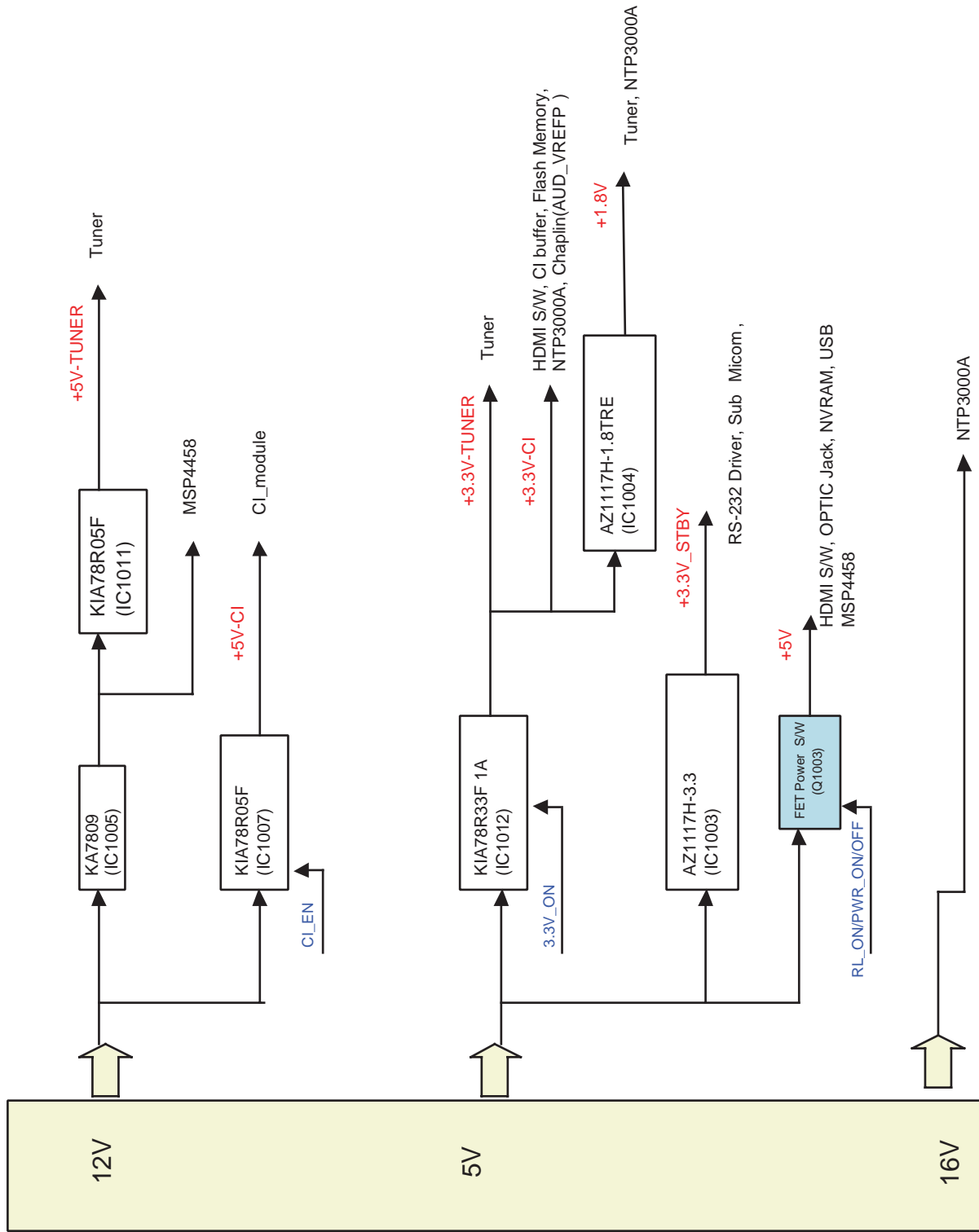

Power Voltage BlockDiagram

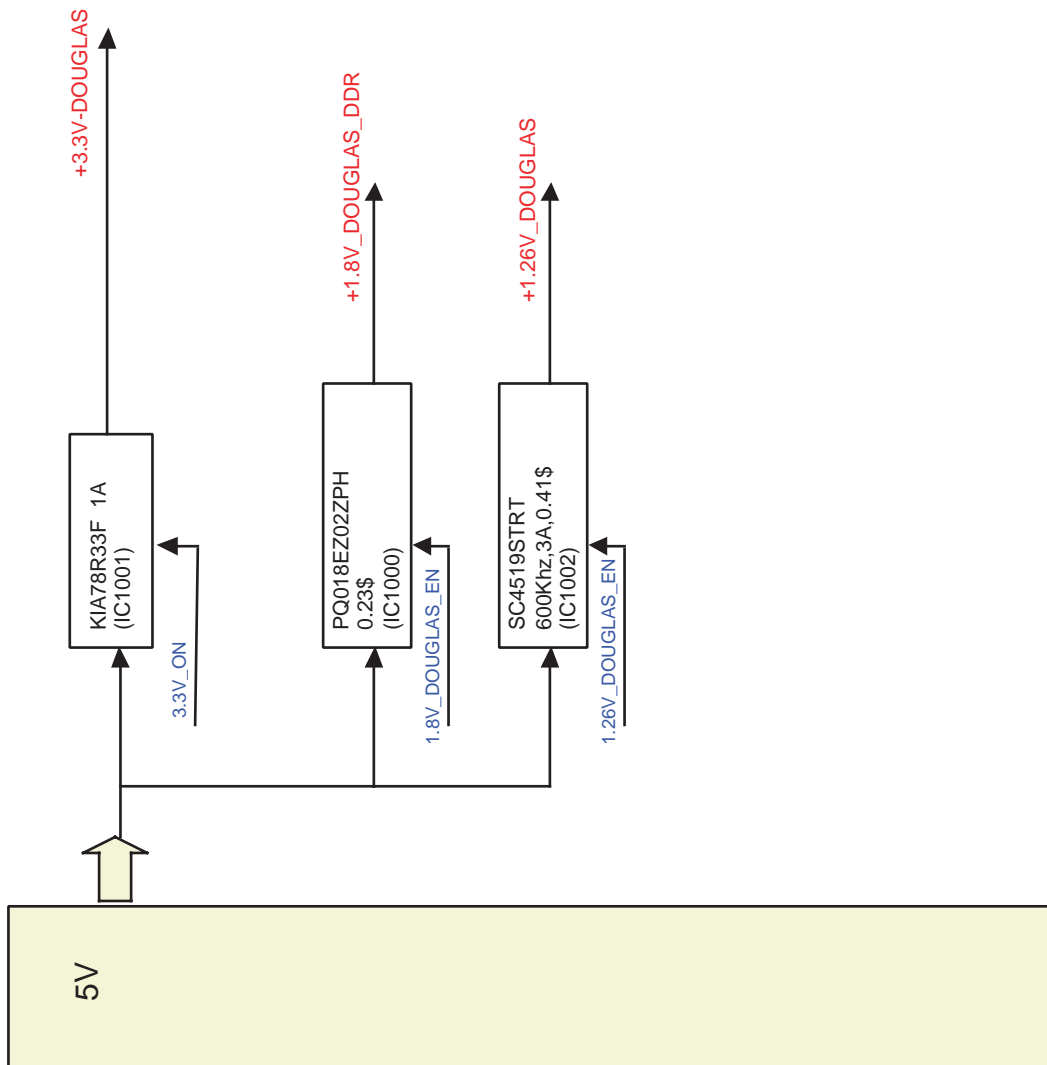

EXPLODED VIEW

IMPORTANT SAFETY NOTICE

Many electrical and mechanical parts in this chassis have special safety-related characteristics. These parts are identified by \triangle in the Schematic Diagram and EXPLODED VIEW. It is essential that these special safety parts should be replaced with the same components as recommended in this manual to prevent X-RADIATION, Shock, Fire, or other Hazards. Do not modify the original design without permission of manufacturer.

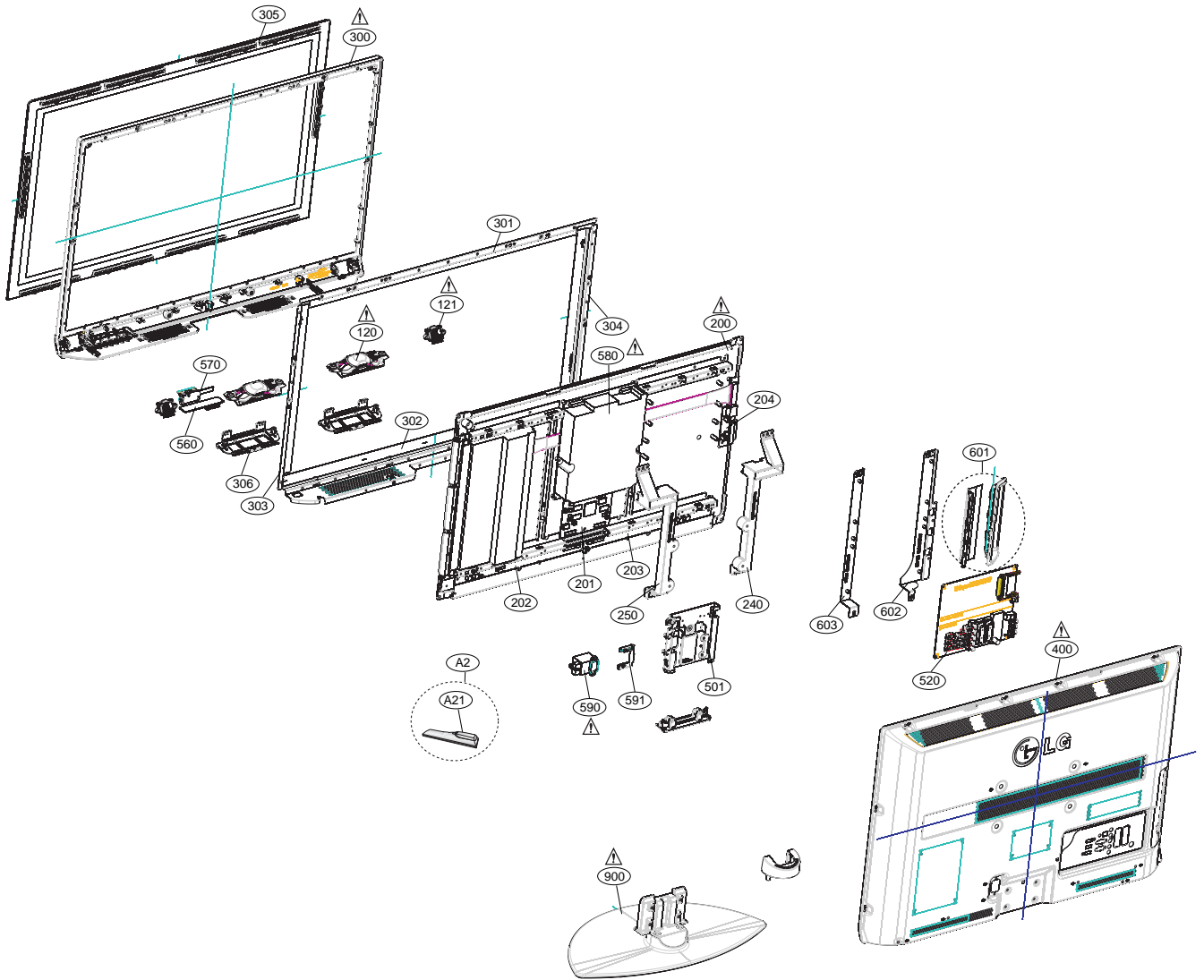

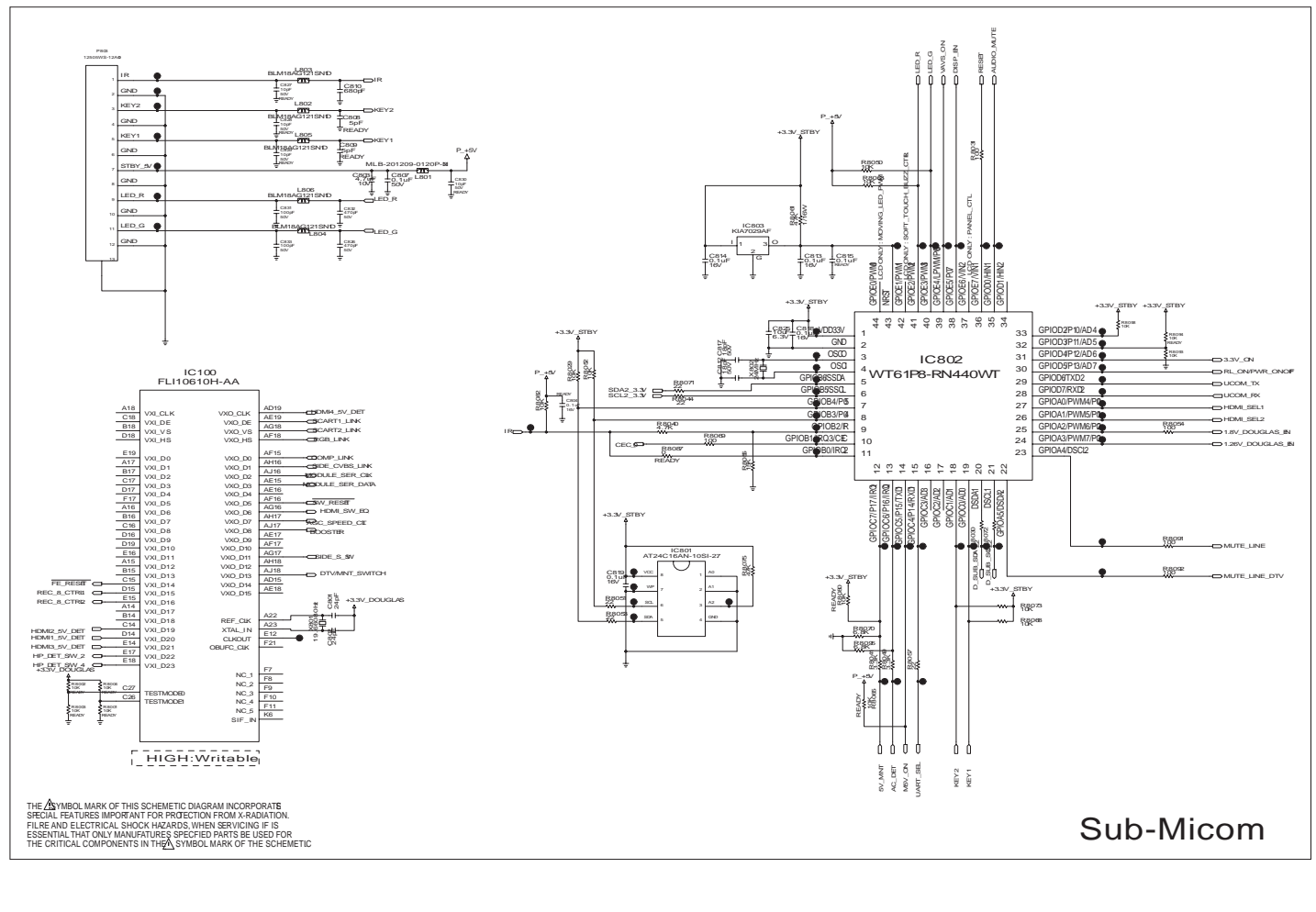
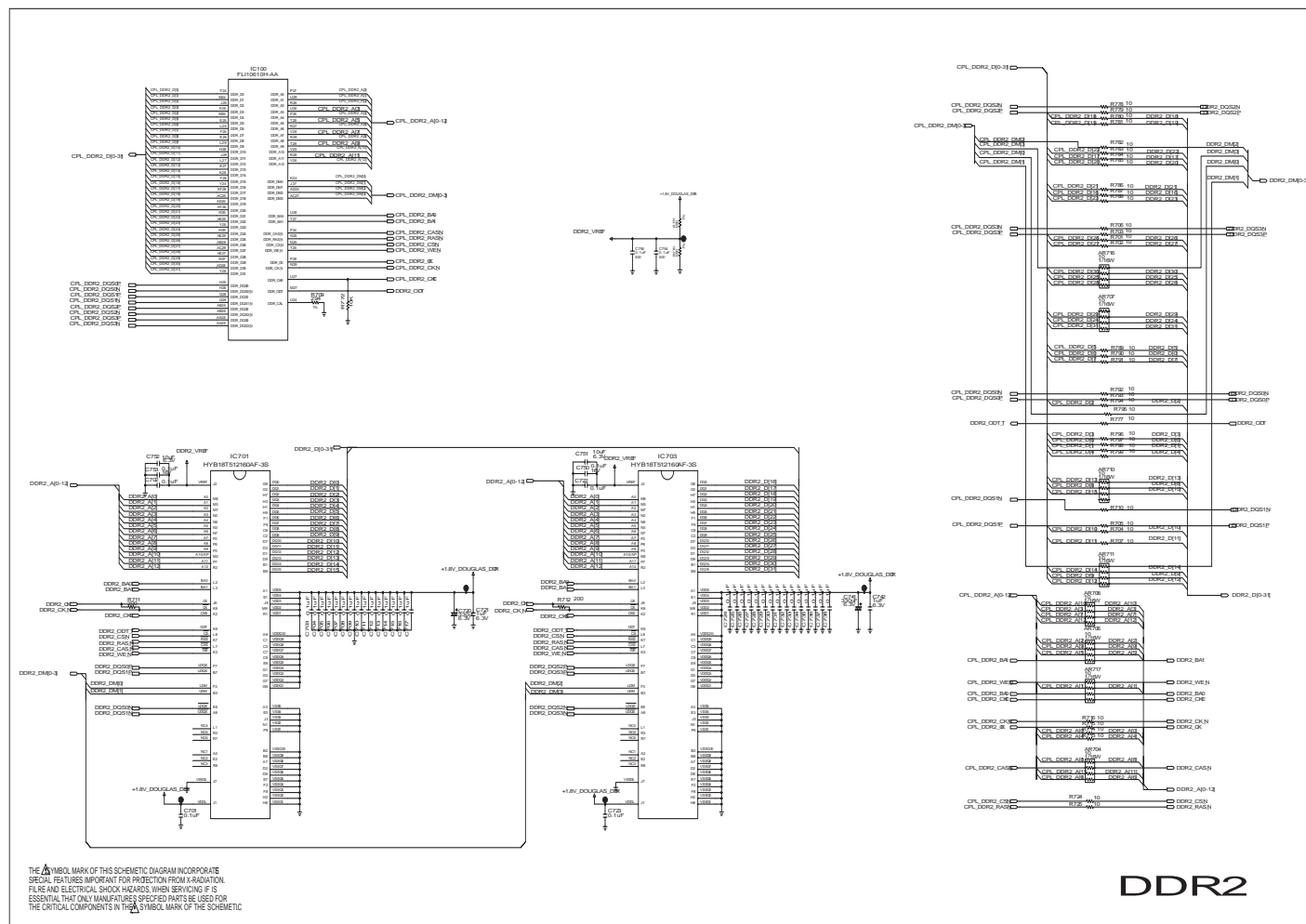
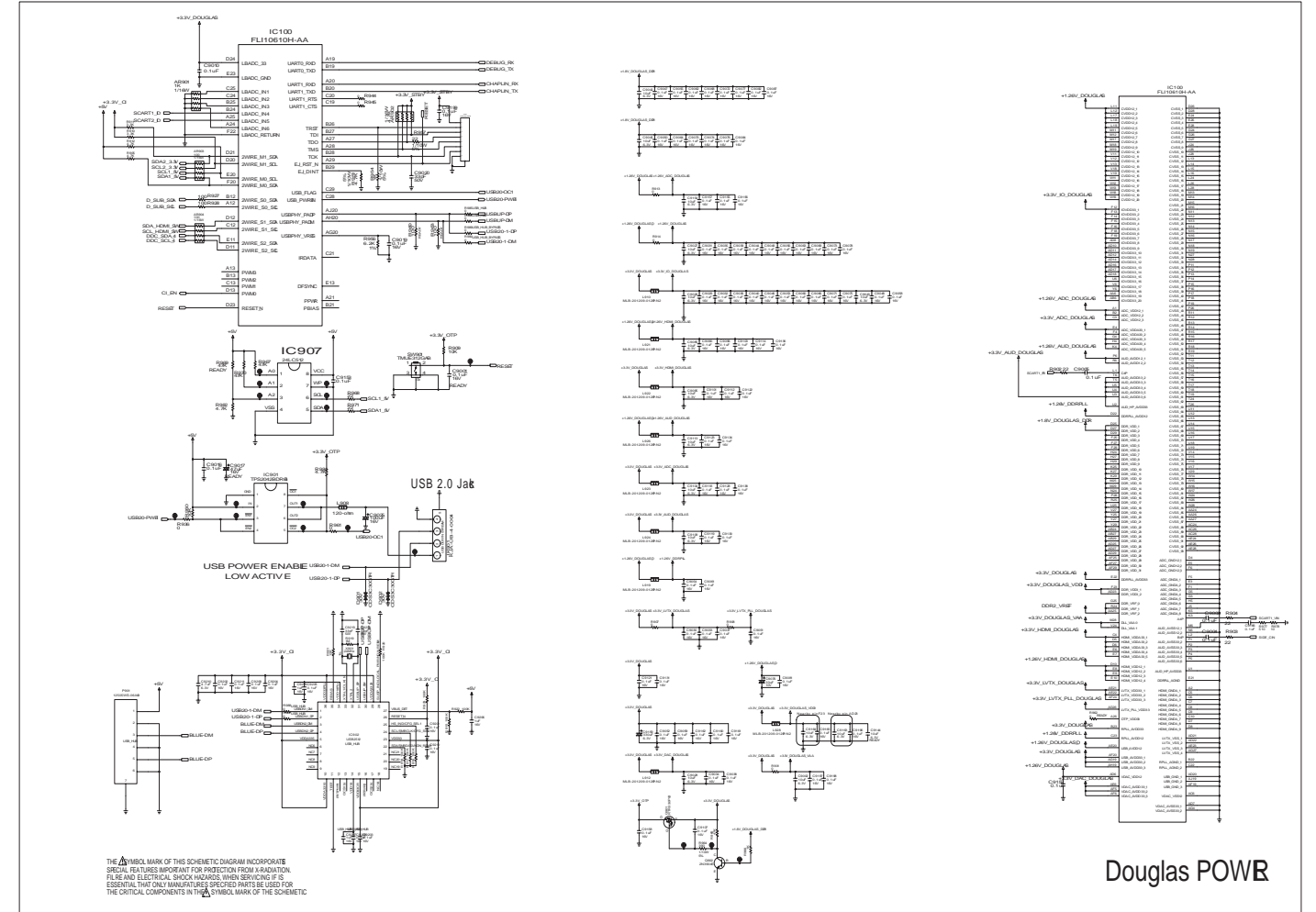
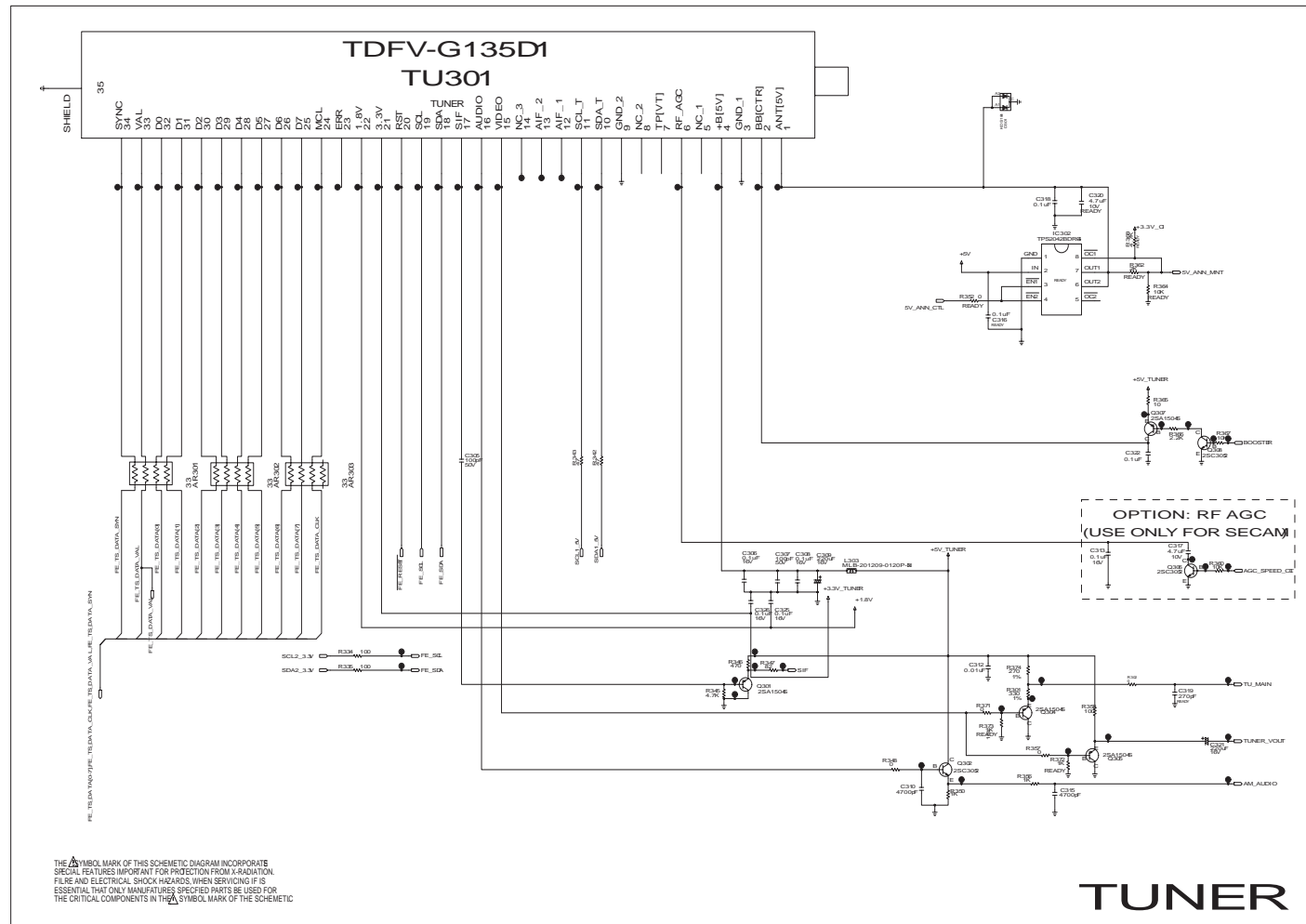

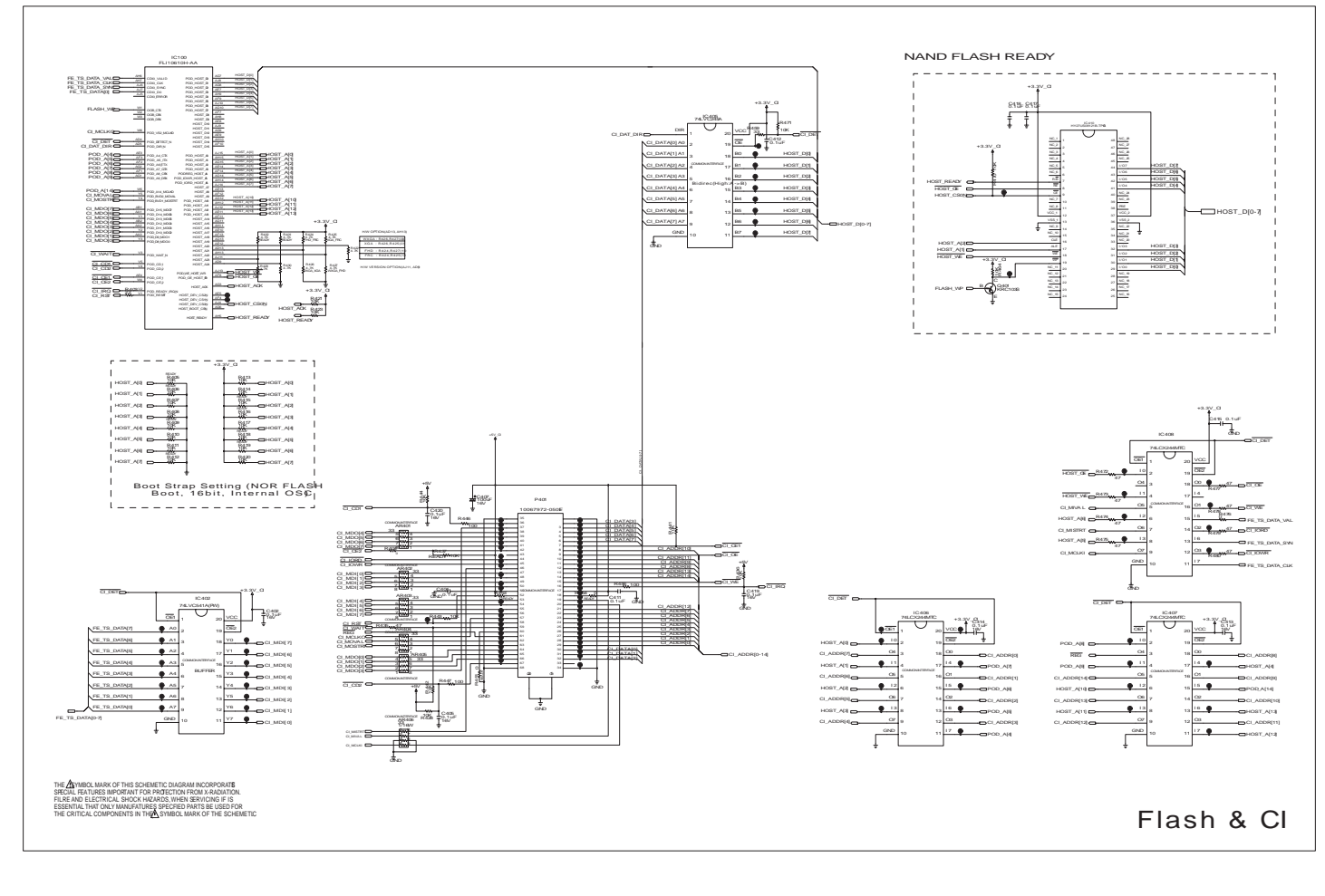
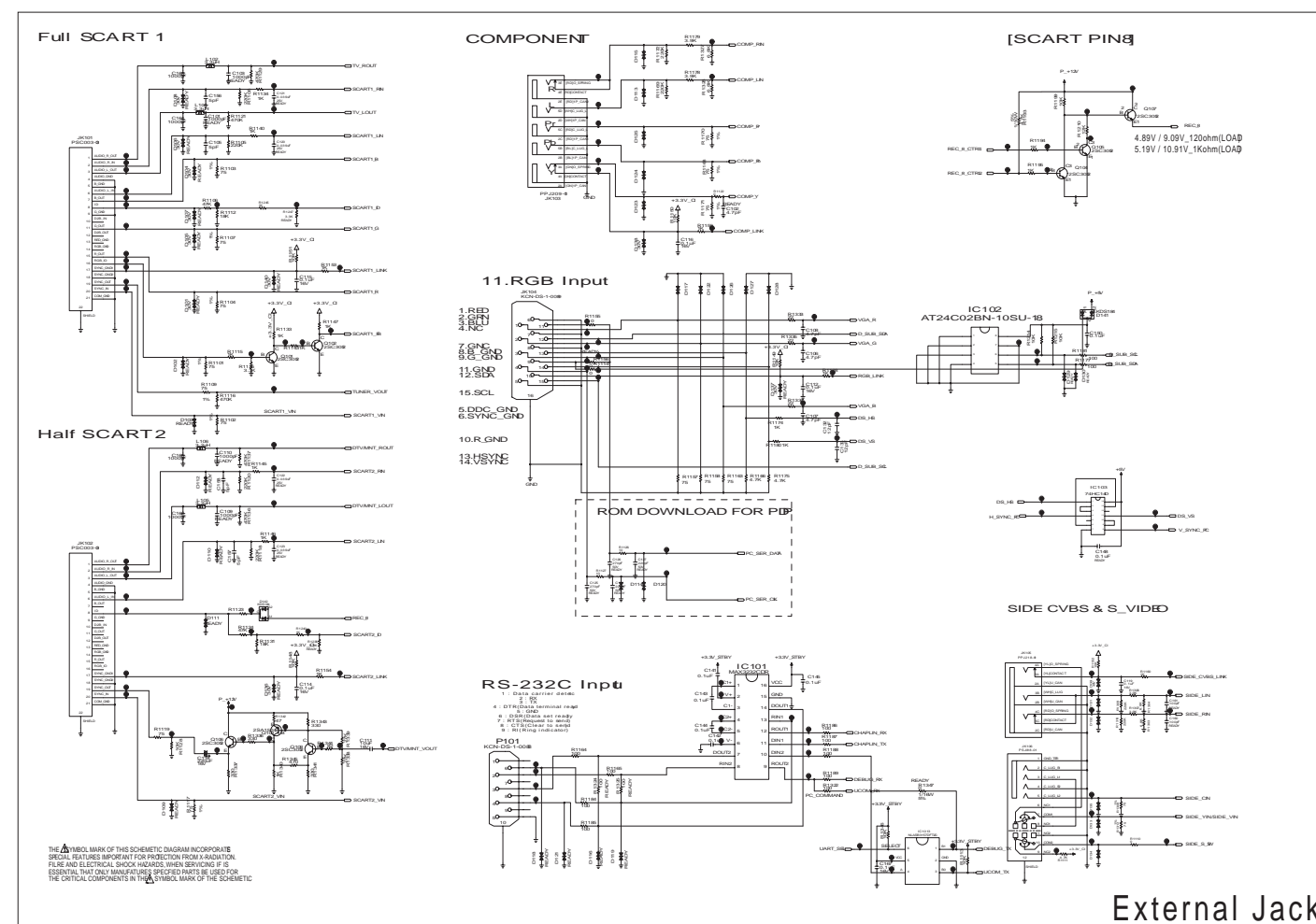
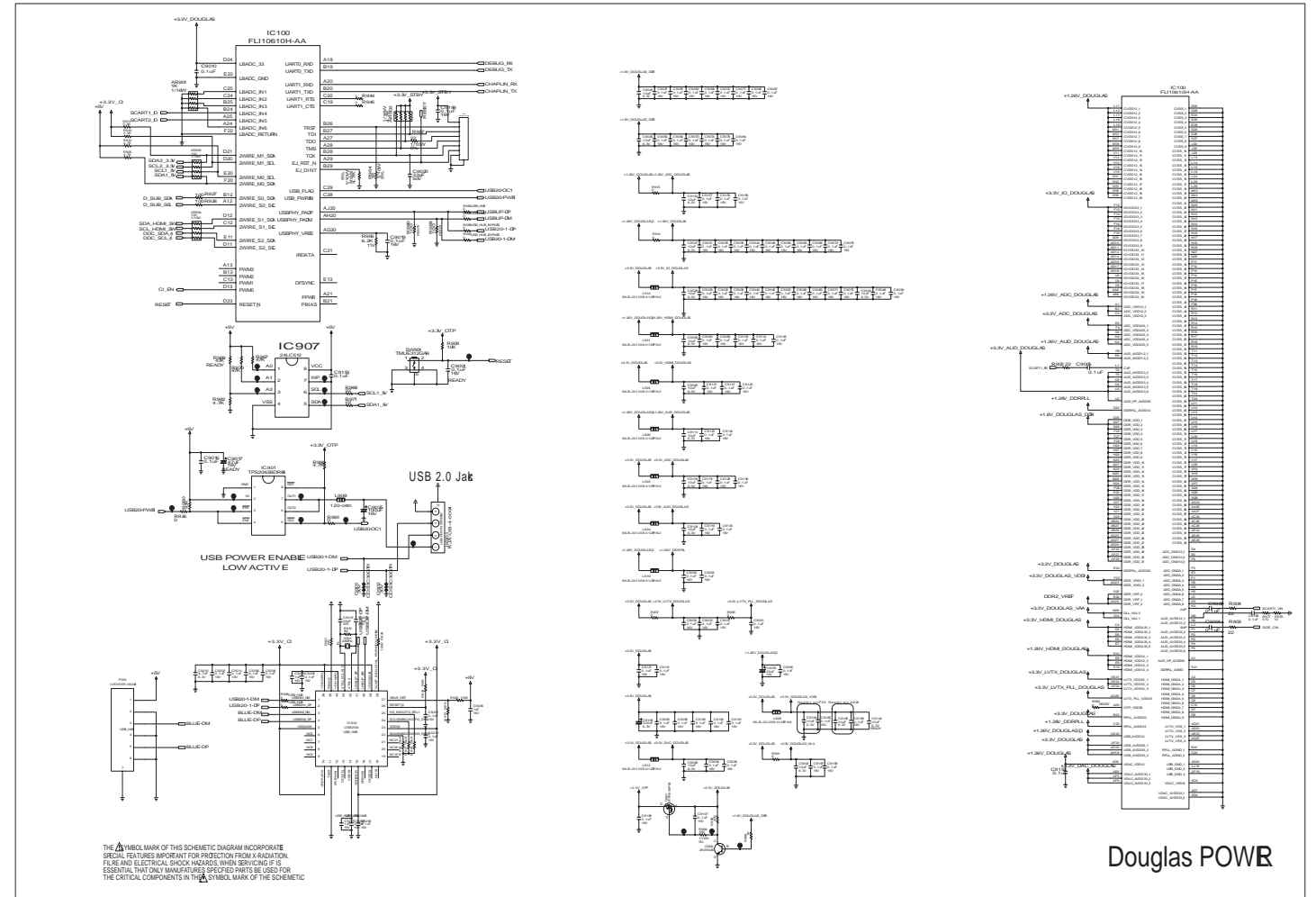
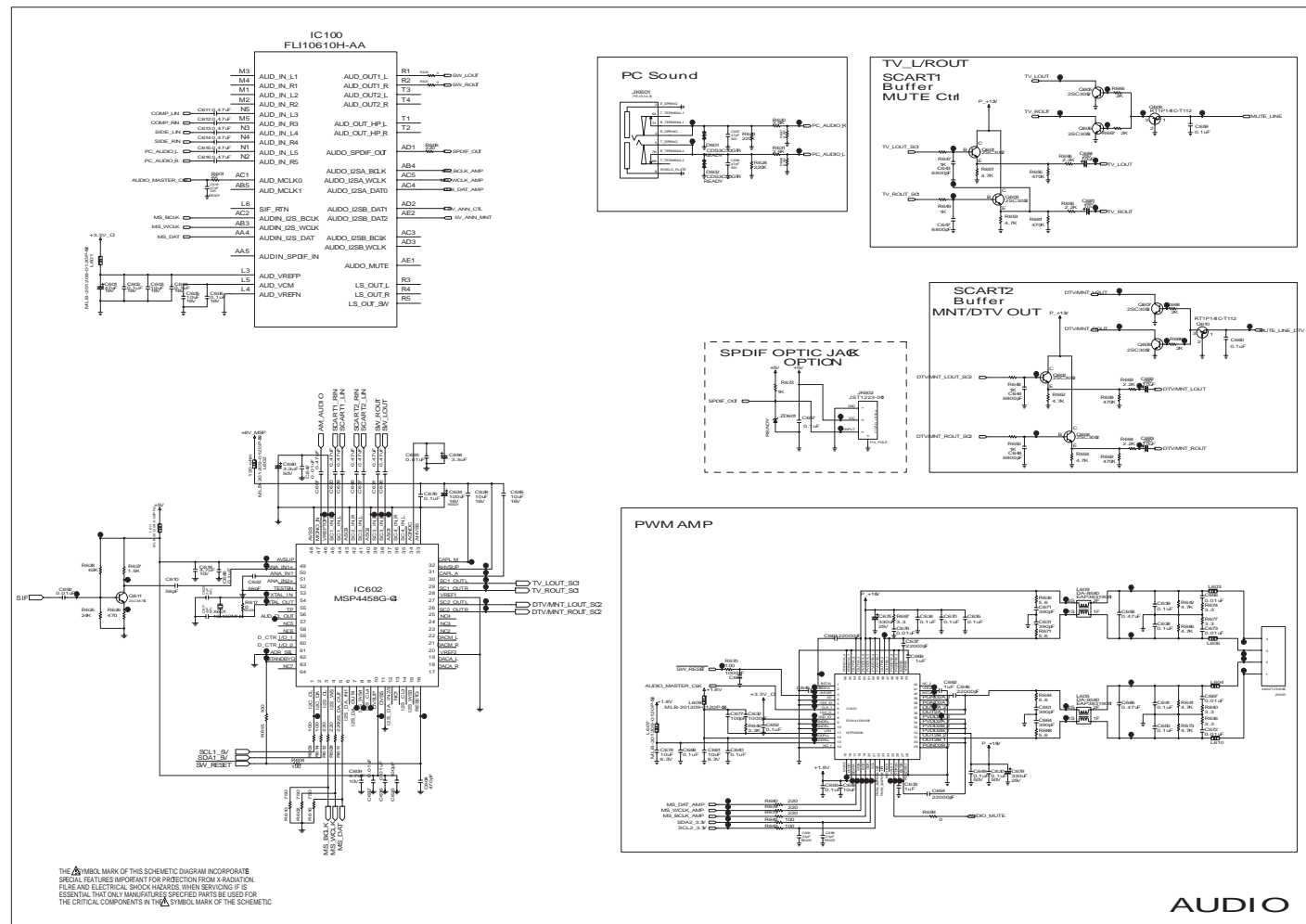

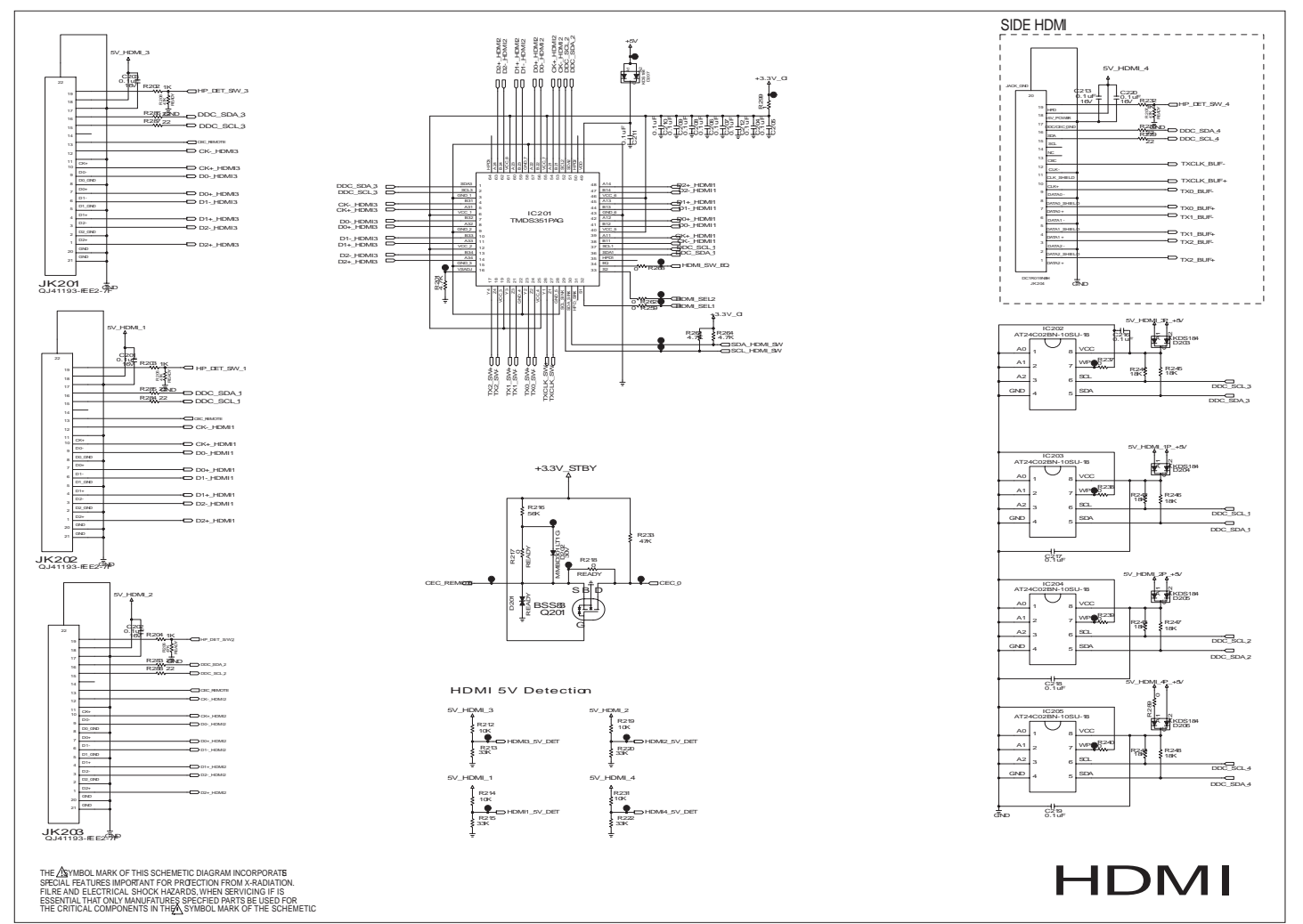
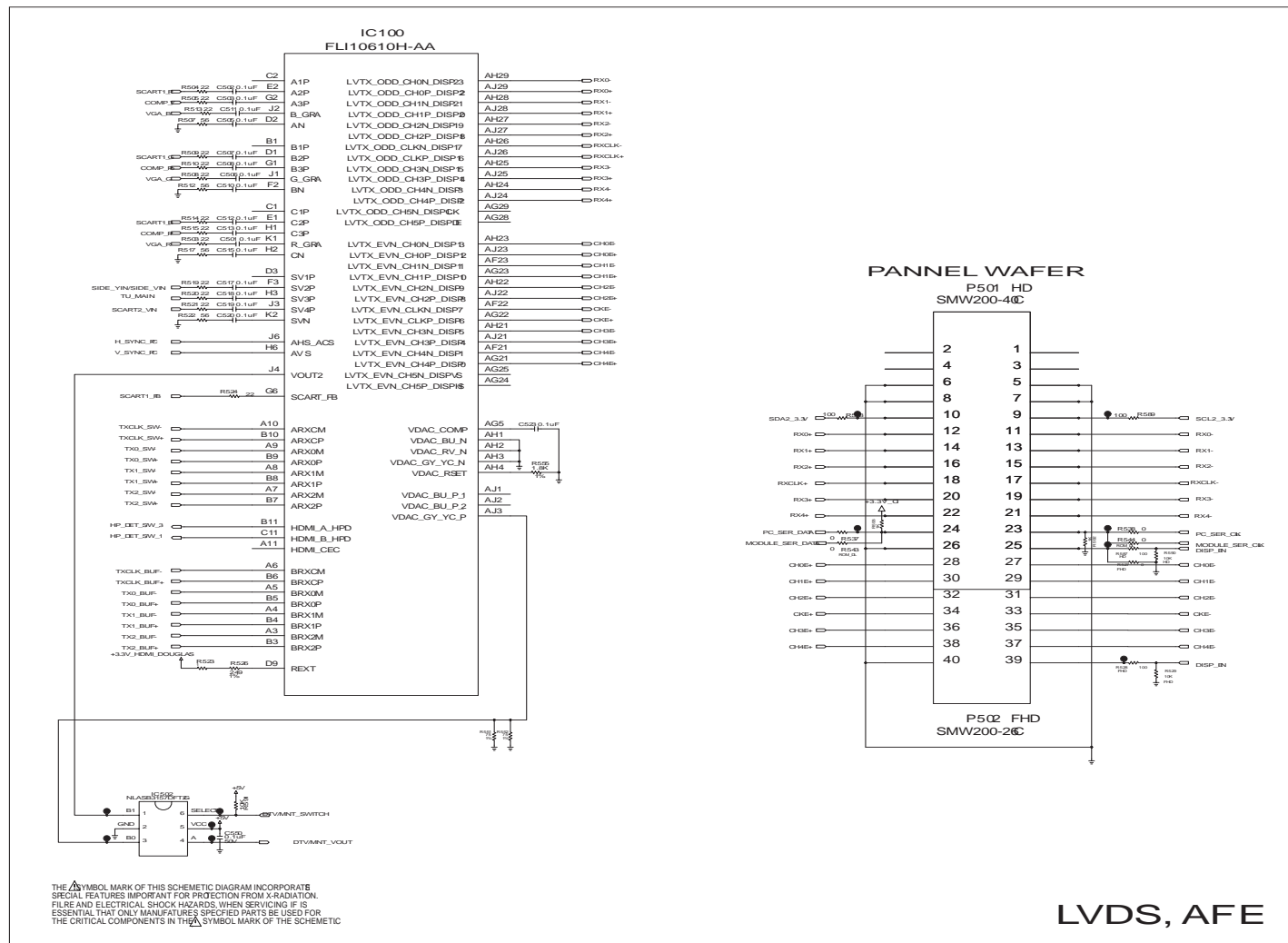

MAIN(TOP)

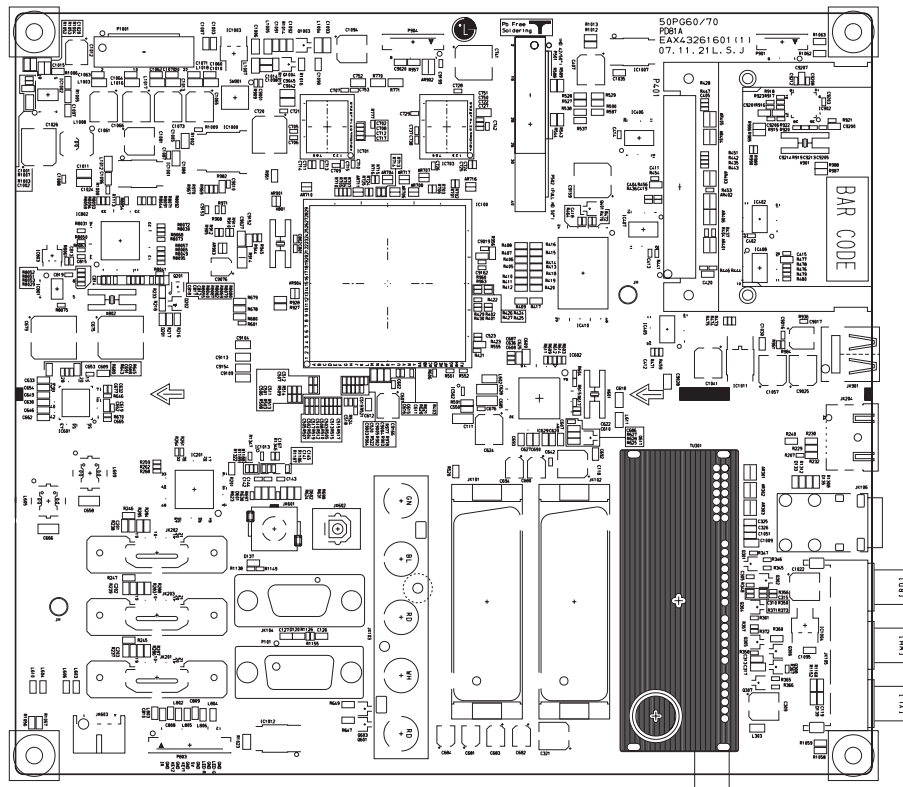

MAIN(BOTTOM)

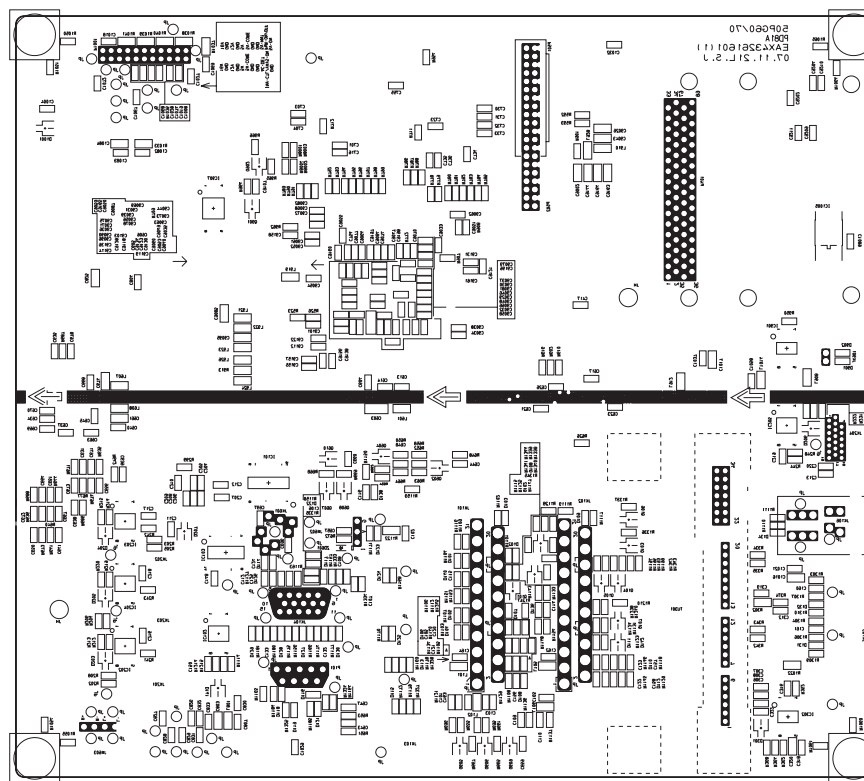

Control B/D(TOP)

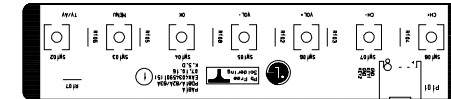

Control B/D(BOTTOM)

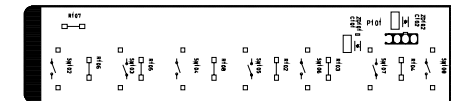

PRE AMP(TOP)

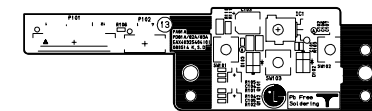

PRE AMP(BOTTOM)

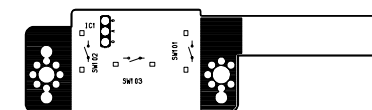



P/NO : MFL41181008

June, 2008
Printed in Korea

