

CIRCUIT DIAGRAM FOR MC-006A CHASSIS MAIN1

P/N : 3854VA0075A-S1(1/2)
Date : 2001.02.01

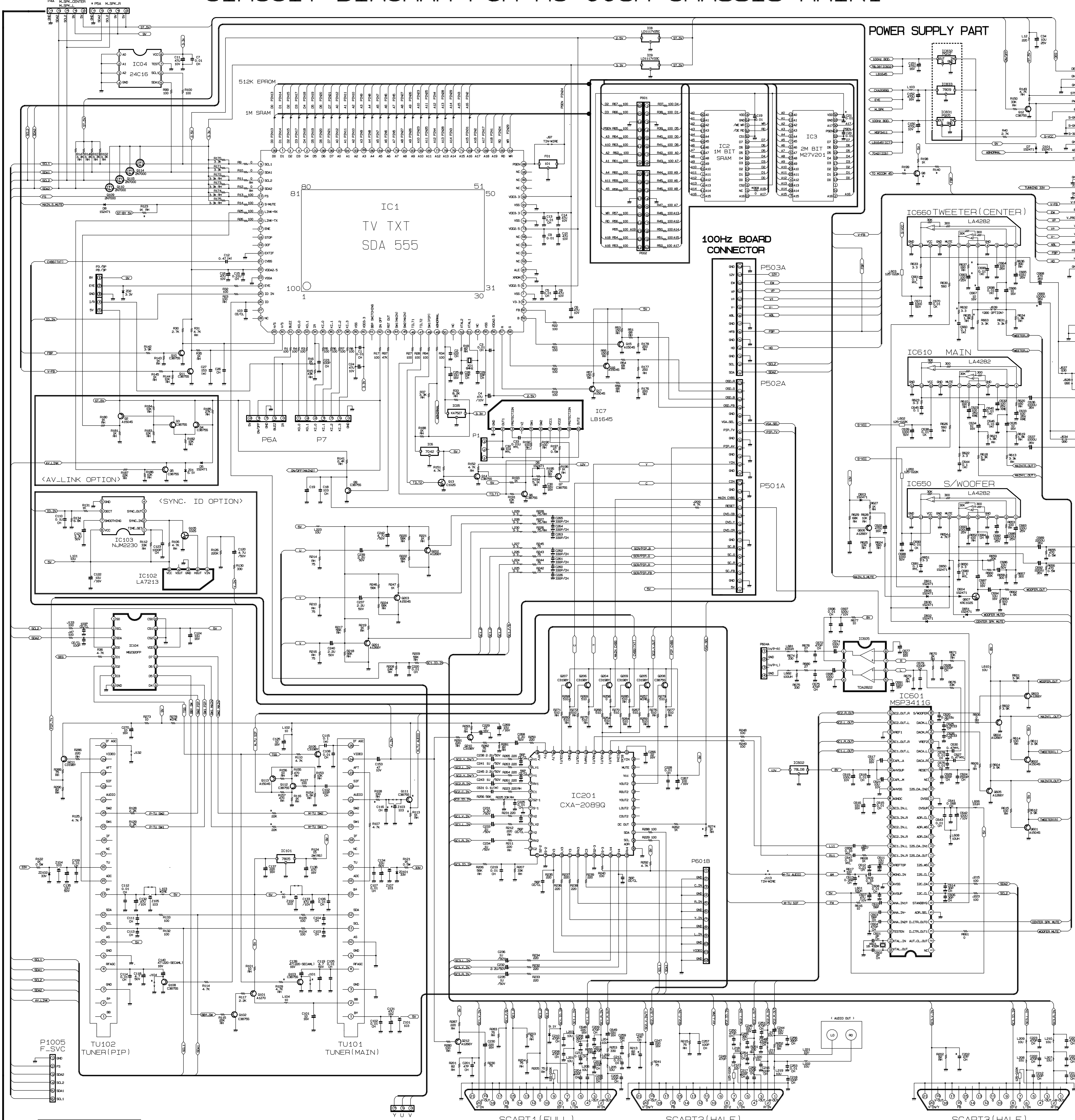

MODEL OPTION
1. MAIN2

REF	QTY	DESCRIPTION	REMARK
C209	470PF	CHP	800PF - CHP
C210	470PF	CHP	800PF - CHP
C250	470PF	CHP	800PF - CHP
C251	470PF	CHP	800PF - CHP
C252	470PF	CHP	800PF - CHP
C253	470PF	CHP	800PF - CHP
J113	100	TIN-WIRE	100 - 1/2W
L6B1	100UH	TIN-WIRE	TIN-WIRE
L6B2	100UH	TIN-WIRE	TIN-WIRE
RE06	0 - 1/10W	IK - 1/10W	IK - 1/10W
RE09	0 - 1/10W	IK - 1/10W	IK - 1/10W
RE17	100 - 1/2W	TIN-WIRE	100 - 1/2W

CIRCUIT DIAGRAM FOR MC-006A CHASSIS 100HZ

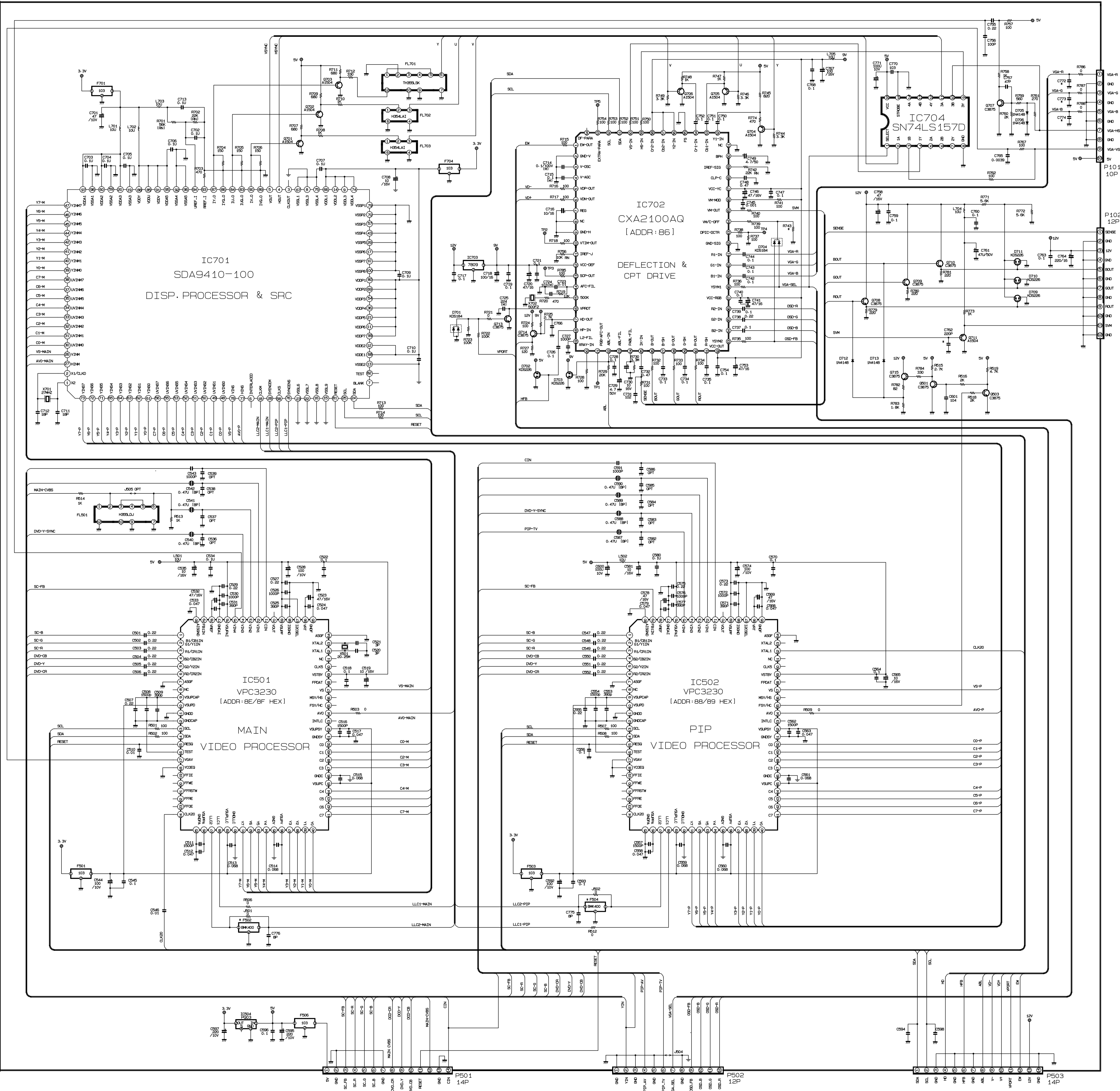

Trouble Shooting

NO POWER ON BUT SMPS WORKING

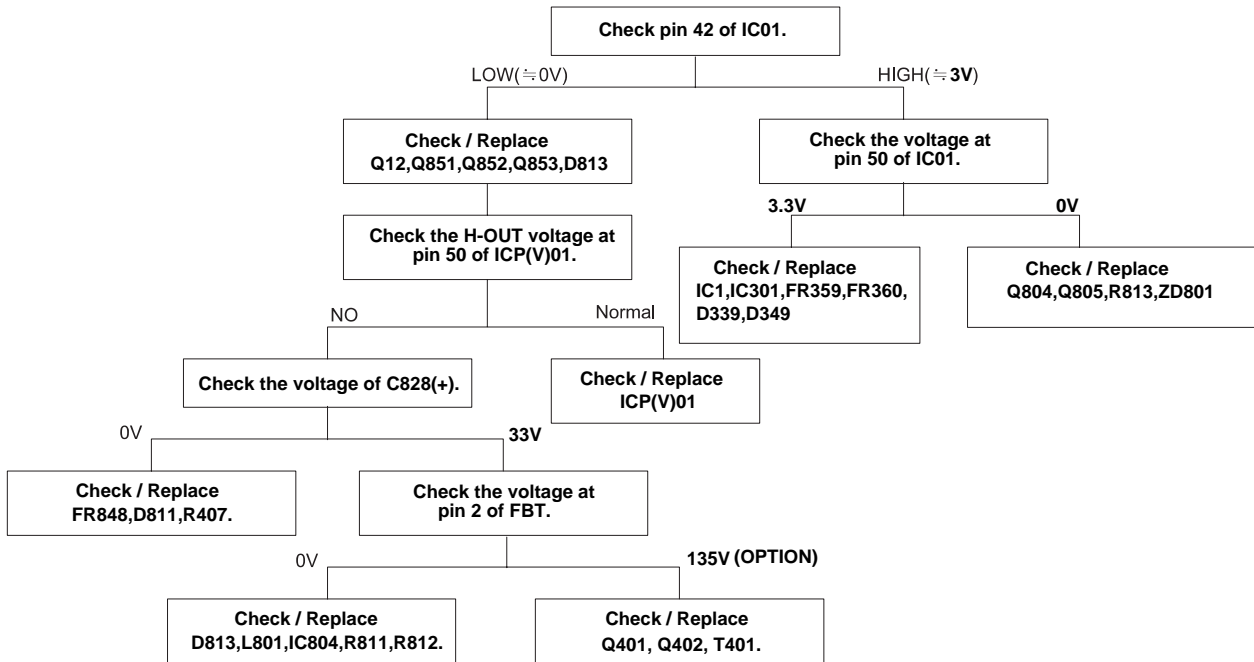

NO POWER (NOT WORKING SMPS)

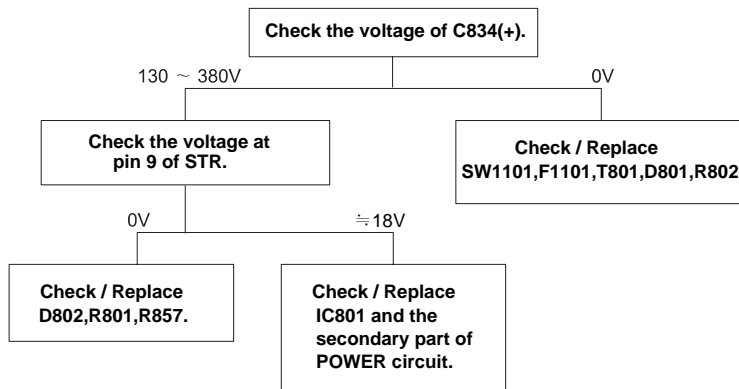

NO RASTER & PICTURE (H-OUT OK)

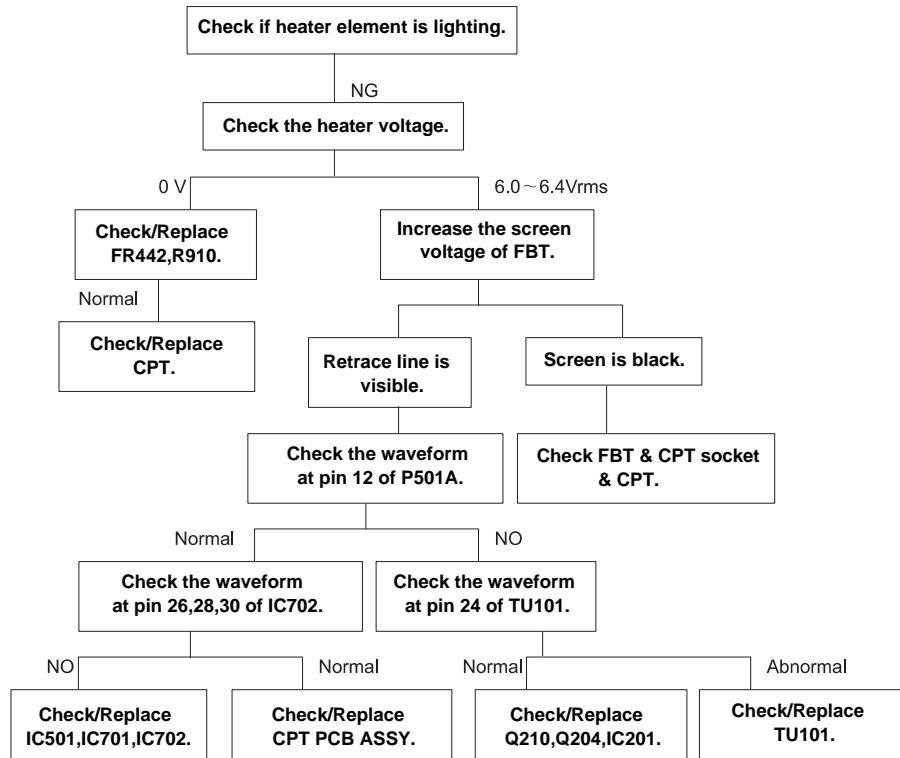

VM DON'T WORKING

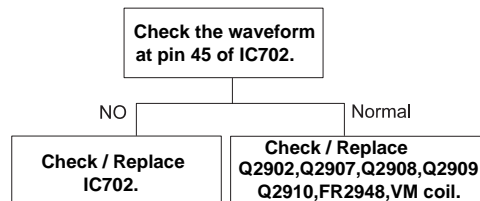

DON'T CATCH CHANNEL(MAIN)

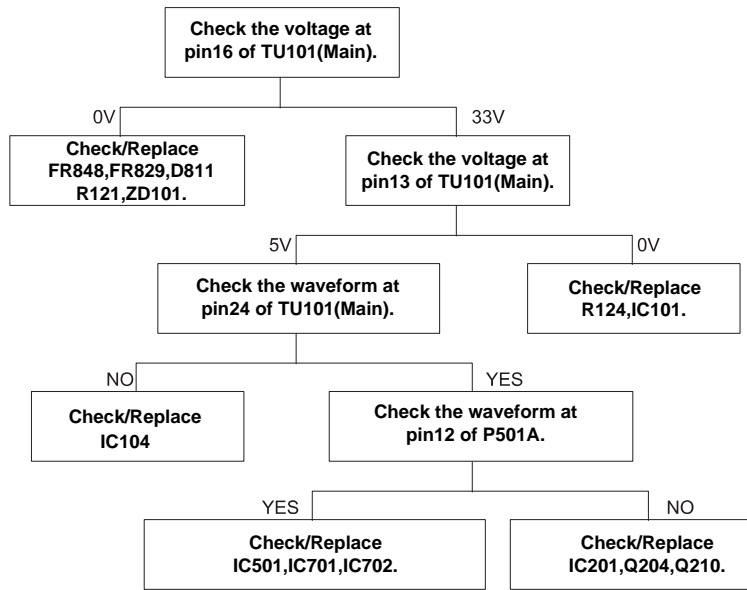

NO PIP / NO DOUBLE WINDOW

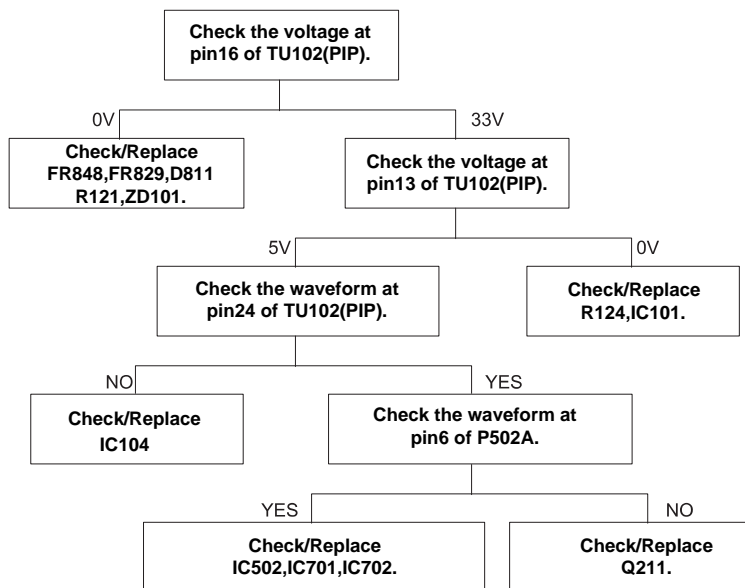

NO CENTER SPEAKER SOUND (BUT MAIN SOUND OK)

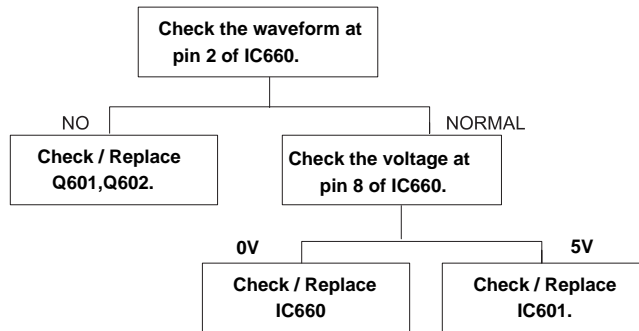

NO WOOFER SPEAKER SOUND (BUT MAIN SOUND OK)

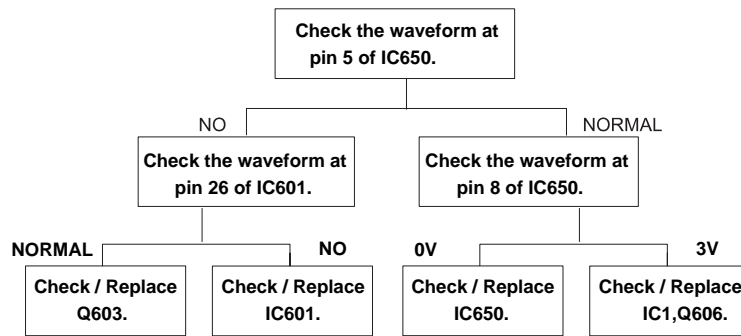

NO TELETEXT

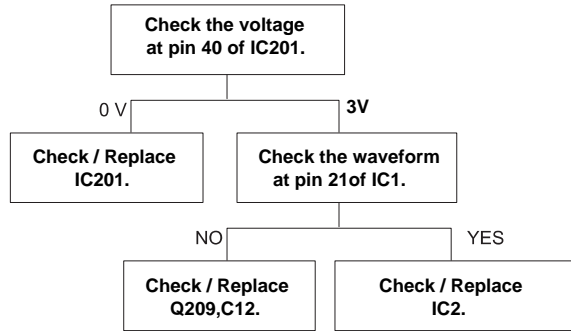

NO VERTICAL DEFLECTION

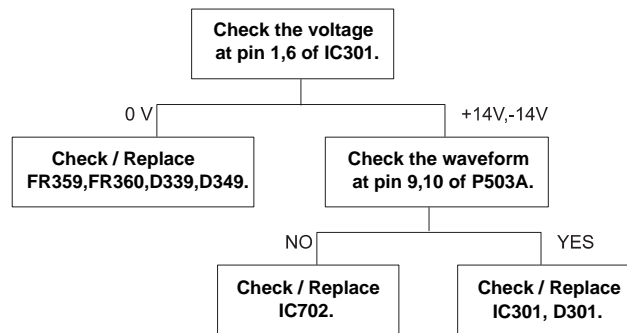

BARREL DISTORTION

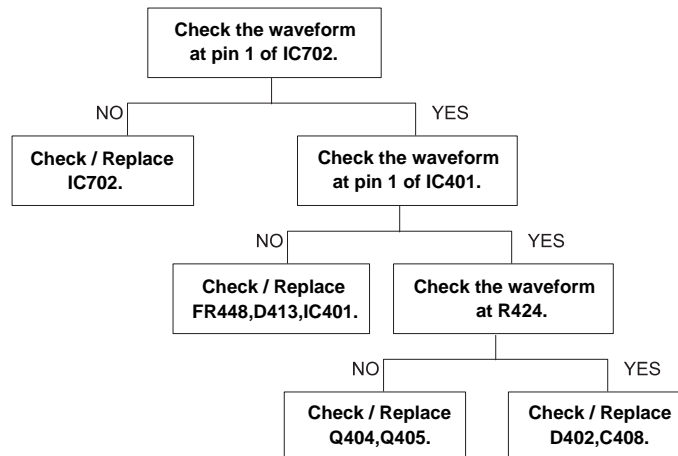

NO FRONT L,R SPEAKER SOUND(PICTURE OK)

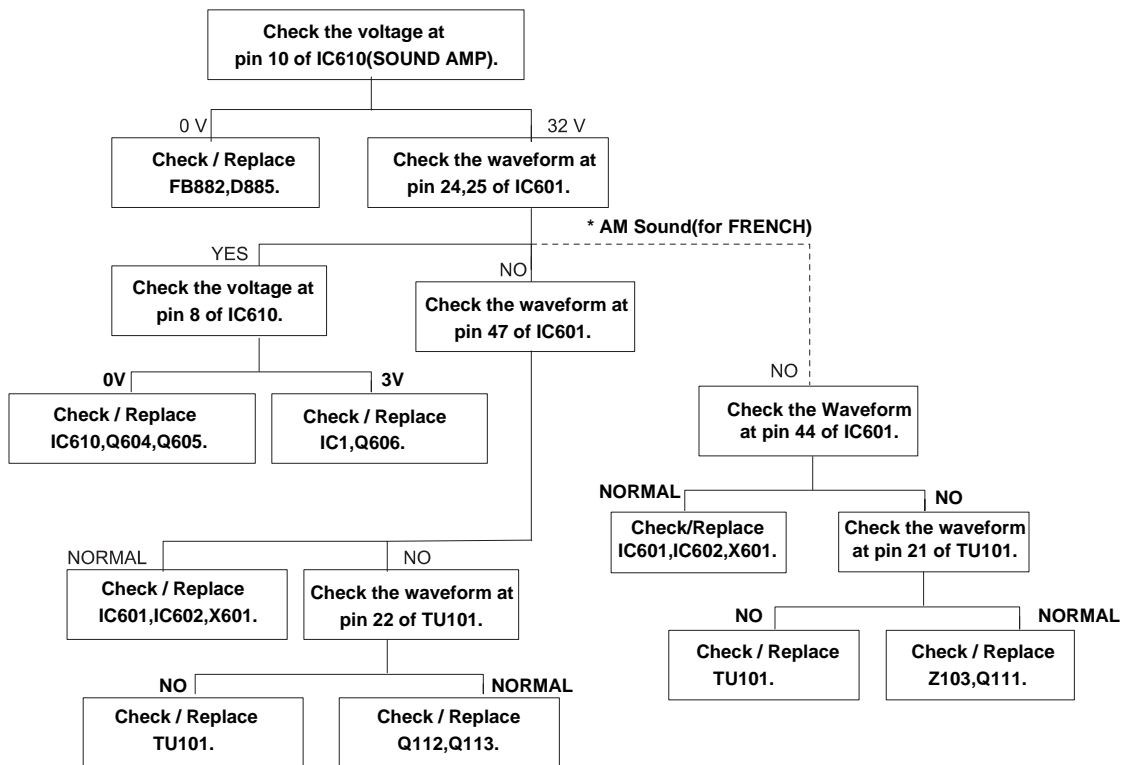

NO SOUND FROM H/P jack(OPTION) (but Main Sound OK)

