

DAEWOO

Service Manual

38 / 48 / 51 Cm Mono Colour Television

CHASSIS : CP-370

MODEL : 14Q1/20Q1/21Q1
14Q2/20Q2/21Q2
14Q3/20Q3/21Q4
14T1/20T1/21T1
14T2/20T2/21T2
14T3/20T3

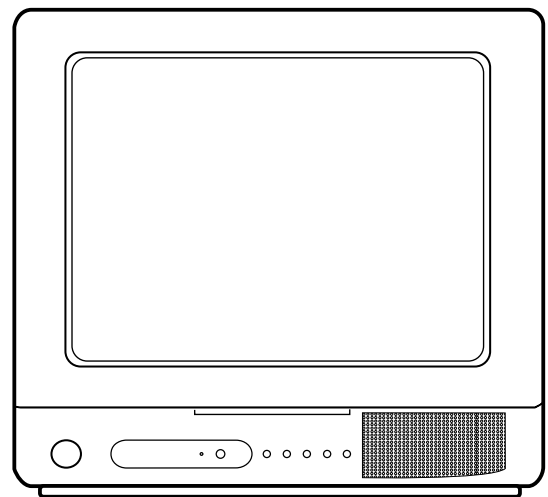

DAEWOO ELECTRONICS CO., LTD.

CONTENTS

Specifications	1
Safety Instruction	2
Circuit block Diagram	3
Alignment Instructions	4
IC Description	7
Circuit Description	31
PCB Layouts	
■ PRINTED CIRCUIT BOARDS	38
■ SCHEMATIC DIAGRAM	39
Trouble Shooting Charis	40
Important IC Voltage Charts	47
Electrical Part List.....	49
Q Model T Model Difference Part List	64
Inch difference Part List	65
Mechanical Exploded View and Part List	66

■ Specifications

※ Q : 1SPEAKER MODEL, T : 2SPEAKER MODEL
 VM : WITHOUT TXT. MODEL, TM : WITH TXT. MODEL

TV Standard	PAL/SECAM-B/G, D/K, I, H, NTSC-3.58/4.43
Mains Voltage	100~250V AC, 50/60Hz
Power Consumption	14"Q = 69W, 14"T = 74W 20"Q = 79W, 20"T = 84W 21"Q = 79W, 21"T = 84W
Sound output	- . 1 Speaker : 3W(at 80% MOD. 10% THD) - . 2 Speaker : 4W + 4W(at 80% MOD. 10% THD)
Speaker	- . 1 Speaker : 3W, 16 ohm - . 2 Speaker : 7.5W, 8 ohm(2EA)
Antenna Impedance	75 ohm unbalanced 300 ohm balanced with supplied balun
Tuning system	Voltage Synthesize Tuning System
Memory channel	VM : 100 channels, TM : 70 channels
Reception channel Unit	VHF - L : CH2 - CH4 VHF - H : CH5 - CH12 Cable Band : CHS1' - CHS3', CHS1 - CHS20 Hyper Band : CHS21 - CHS40(option) UHF : CH21 - CH69
Remote control	VM : R-28B04, TM : R-28B03
Screen size	14" : 34cm (A34JLL 90 × 02) 20" : 48cm (A48JLL 90 × 02) 21" : 51cm (A51JLL 90 × 02)
Weight	14" : 9.5Kg(set) 20" : 16.5Kg(set) 21" : 20.5Kg(set)
Indication	On-Screen Display - MENU · Picture(Bright, Color, Contrast, Sharpness, TINT) · TIMER(CLOCK, WAKE-UP-TIME, ACTIVATE, WAKE-UP-PROG) · LANGUAGE · PRESET · EDIT · SLEEP TIMER · AV · SOUND MUTE · VOLUME CONTROL

Alignment Instructions

1. AFT

1.1 Standard B/G,D/K,I

- 1) Set a Signal Generator with
 - RF FREQUENCY = 38.9 MHz,
 - RF OUTPUT LEVEL = 80 ± 5 dBuV
 - System = PAL / SECAM - B/G, D/K, I
NTSC - 3.58/4.43
- 2) Connect the Signal Generator RF Output to P101 (Tuner IF Output).
There must be no signal input to the tuner.
- 3) Press the "AFT" KEY and wait until the TV screen display "AFT OK".

2. AGC

- 1) Set a Pattern Generator with RF LEVEL 63 ± 2 dBuV .
- 2) Connect a OSCILLOSCOPE PROBE to P102 (TUNER AGC INPUT).
- 3) Adjust AGC UP/DOWN KEY the voltage drop 3.5V dc point its maximum voltage.(TDA8374A N1 VERSION)
 - ※ Adjust AGC UP/DOWN KEY the voltage drop 1.5V dc over blow its maximum voltage(TDA8374A N3 VERSION)

* Alternative Method

- 1) Set a Pattern Generator with
 - RF LEVEL 80 ± 5 dBuV
 - PAL CROSSHATCH
(without SOUND CARRIER)
- 2) Connect a OSCILLOSCOPE
(Bandwidth ≥ 100 MHz) PROBE
to P101 (TUNER IF OUTPUT).
- 3) Use AGC UP/DOWN KEY to obtain
an envelop amplitude $200 + 20$ mVp-p.

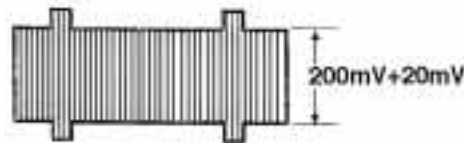

3. SCREEN

- 1) Apply a COLOR BAR pattern signal.
- 2) Set the CONTRAST, BRIGHTNESS to MAX, COLOR to MIN.
- 3) Set the R,G,B LEVEL to CENTER (31/63) with R,G,B UP/DOWN KEY.
- 4) Connect a OSCILLOSCOPE PROBE to P904 (CRT CATHOD R, G, B).
- 5) Adjust the SCREEN VOLUME on FBT such that the highest black level voltage 160 ± 5 Vdc (20", 21"), 130 ± 5 Vdc (14").

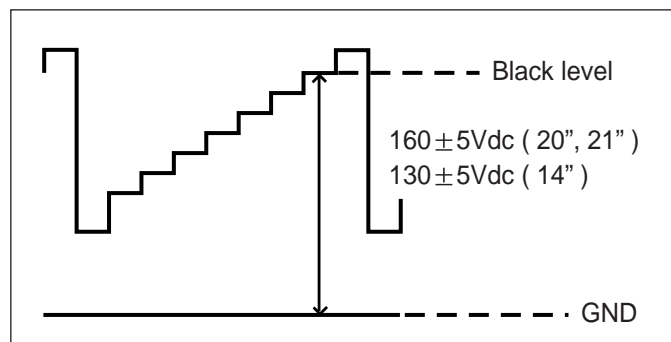

4. WHITE BALANCE

- 1) Set the TV to NOR I mode.
- 2) Set the R,G,B LEVEL to CENTER with R,G,B UP/DOWN KEY .
- 3) Adjust the R,G,B UP/DOWN KEY of the other color which did not appear on the screen to obtain WHITE.

5. FOCUS

- 1) Apply a RETMA PATTERN signal.
- 2) Adjust the FOCUS VOLUME on FBT to obtain optimal resolution.

6. GEOMETRY

6.1 VERTICAL CENTER

- 1) Set the TV to NOR I mode.
- 2) Pressing the V-SIZE UP/DOWN KEY, the lower half of the screen is blanked.
- 3) Adjust the border line of blanked picture coincident with the mechanical center marks of the CRT using the V-CENTER UP/DOWN KEY.

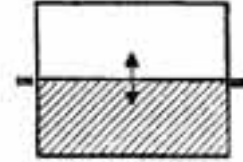

6.2 VERTICAL SIZE

- * The VERTICAL CENTER adjustment has to be done in advance.
- 1) Apply a RETMA PATTERN signal.
 - 2) Set the TV to NOR I mode.
 - 3) Adjust the upper part of the picture with the V-SIZE UP/DOWN keys.

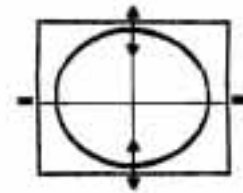

6.3 VERTICAL SLOPE

- * The VERTICAL SIZE adjustment has to be done in advance.
- 1) Apply a RETMA PATTERN signal.
 - 2) Adjust the lower part of the picture with the V-SLOPE UP/DOWN keys.

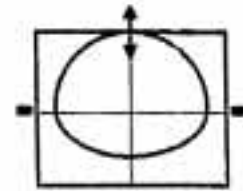

6.4 VERTICAL S-CORRECTION

- 1) Apply a CROSSHATCH PATTERN signal.
- 2) Adjust the S-COR UP/DOWN KEY to obtain the same distance between horizontal lines.

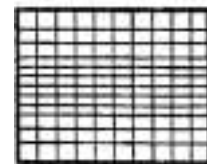

6.5 HORIZONTAL CENTER

- 1) Apply a RETMA PATTERN signal.
- 2) Adjust picture centering with H-CENTER LEFT/RIGHT keys.

If EEPROM(1703) has been changed ;

- Option data has to be changed and
- all alignment function has to be readjusted.

* The initial state of adjustment are as follows;

- V-Center, V-Slope V-Size, H-Center, R, G, B, AFT = Center (30/64 - 33/64)
- S-Correction = 00/64
- AGC = 15~60/64

* Service Remocon

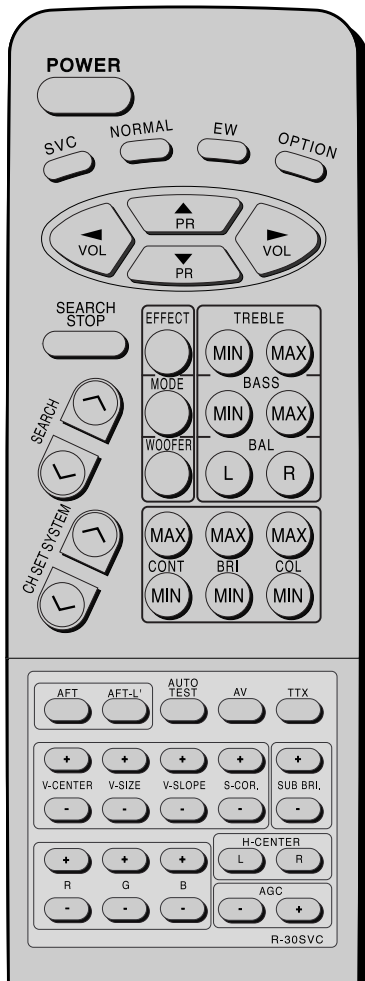

■ IC Description

DW370ASM* (Micro-controller for Non-Teletext Model) =TMS370C08A05 (TI Type No.)

(1) General Description

The TMS370C08A05 devices are members of the cMCU370 family single-chip microcontrollers.

The cMCU370 family provides cost effective real-time system control through use of the PRISM methodology.

The PRISM methodology modular fabrication process integrates analog, digital, linear and power technologies on a single chip, thereby maximizing the total integration strategy.

The TMS370C08A05 devices are designed with the high-performance 8-bit TMS370C8 CPU.

Features of the 'C8 CPU and system module as implemented on this device include three CPU registers (stack pointer, status register, and the program counter), two external interrupts, reset, memory mapped control registers.

(2) Feature

• Internal Memory Configurations

- 16K-Byte ROM Program Memory
- 512-Byte RAM

• Operating Features

- Supply Voltage (VCC) $5\text{ V} \pm 10\%$
- Input Clock Frequency 2, 20MHz
- Industrial Temperature Range

• Device Integrity Features

- Address Out-of-Range Reset
- Stack Overflow Reset
- Parallel Signature Analysis (CRC)

• Two 16-Bit General Purpose Timer(T8A)

Each Includes:

- 16-Bit Resettable Counters with individual 8-Bit Prescaler
- 2 PWM Channels or
- 2 Input Captures or
- 1 Input Capture and 1 PWM Channel

• One 14-Bit PWM Module

- 14-Bit Resettable Counters
- 14-Bit PWM Output Port

• One 8-Bit PWM Module

- 8-Bit Resettable Counters
- 8-Bit PWM Output Port with 12V Open Drain

• OSD Module

- Blanking/ Contrast reduction out
- Transparent Background
- Transparent Foreground
- Full Screen Background Color
- Controlled Color, Blink, Size, Smoothing, Fringe of Each lines of Character
- Two size of different Font 12x10 and 12x18 by Hard Masking
- OSD Window Display with 40x25 lines

• 8-Bit A/D Converter With 3 Inputs

- Single or Dual Channel Operation
- Single or Continuous Conversion Modes

• Flexible Interrupt Handling

- Global and Individual Interrupt Masking
- 2 S/W Programmable Interrupt Levels
- 2 External Interrupt (1 Non-Maskable)
- Programmable Rising or Falling Edge Detect

- **09 CMOS Compatible I/O Pins**

- All Peripheral Function Pins Software Configurable for Digital I/O
- 6 Bidirectionals, 3 Input Pins

- **Plastic 42 YSDP Pins Package**

(3) Block Diagram

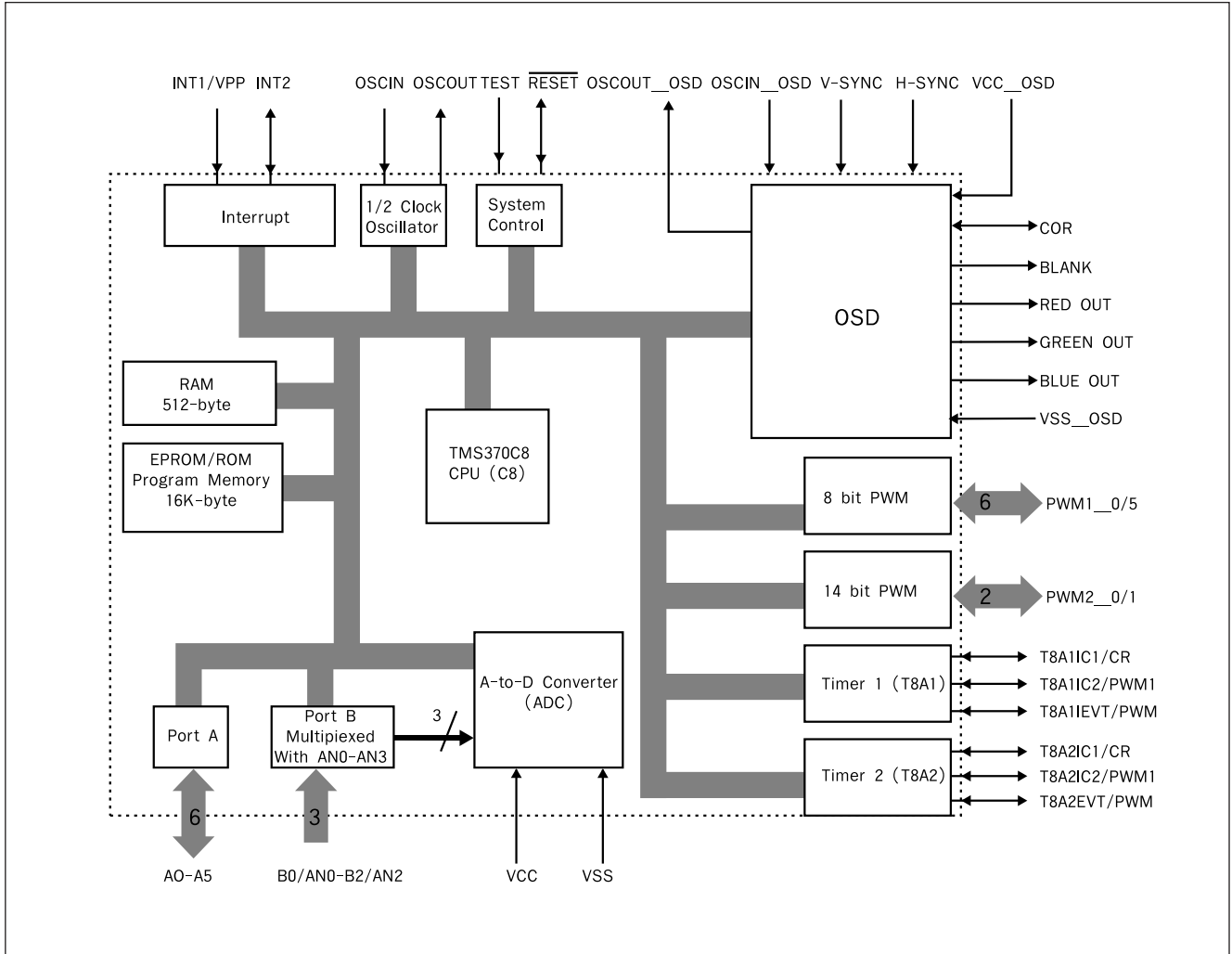

DW5255M*(Micro-controller & West/East Teletext Decoder) **DW5255RM*(Micro-controller & Cyrillic Teletext Decoder)** **=SDA5255-A*** (SIEMENS Type No.)**

(1) General Description

The TDA5255 contains a slicer for VPS and TTX, an accelerating acquisition hardware module, a display generator for "LEVEL 1" TTX data and a 8 bit u-controller running at 333 nsec cycle time.

The controller with dedicated hardware guarantees flexibility, does most of the internal processing of TTX acquisition, transfers data to/from the external memory interface and receives/transmits data via I2C and UART user interfaces.

The Slicer combined with dedicated hardware stores TTX data in a VBI 1Kbyte buffer.

The u-controller firmware does the total acquisition task (hamming- and parity -checks, page search and evaluation of header control bits) once per field.

(2) Feature

• Acquisition:

- feature selection via special function register
- simultaneous reception of TTX and VPS
- fixed framing code for VPS and TTX
- programmable framing code window for TTX
- Acquisition during VBI
- direct access to VBI RAM buffer
- Acquisition of packets x/26, x/27, 8/30 (firmware)
- assistance of all relevant checks (firmware)
- 1-bit framing-code error tolerance (switchable)

• Display:

- features selectable via special function register
- 50/60 Hz display
- level 1 serial attribute display pages
- blanking and contrast reduction output
- 8 direct addressable display pages
- 12 x 10 character matrix
- 96 character ROM (standard G0 character set)
- 143 national option characters for 11 languages
- 288 characters for X/26 display
- 64 block mosaic graphic characters
- 32 free addressable characters for OSD in expanded character ROM + 32 inside OSD box
- double height (TOP/BOTTOM)
- conceal/reveal
- transparent foreground/background -inside/outside of a box
- cursor (colour changes from foreground to background colour)
- flash (flash rate 1s)
- programmable horizontal und vertical sync delay
- hardware assisted fast display page erase
- full screen background colour in outer screen

• Synchronization:

display synchronization to sandcastle or Horizontal Sync (HS) and Vertical Sync (VS) with startstop-oscillator or display synchronization to sandcastle or Horizontal Sync and Vertical Sync with external clock independent clock systems for acquisition, display and controller

- **Controller:**

- 8 bit configuration
- 18 MHz internal clock
- 0.33 us instruction cycle
- eight 16-bit data pointer registers (DPTR)
- two 16-bit timers
- watchdog timer
- serial interface (UART)
- 256 bytes on-chip RAM
- 1 Kbyte on-chip extended RAM (access via MOVX)
- 8 Kbyte on-chip ACQ-buffer-RAM (access via MOVX)
- 6 channel 8-bit pulse width modulation unit
- 2 channel 14-bit pulse width modulation unit
- 4 multiplexed ADC inputs with 8-bit resolution
- one 8-bit I/O port with open drain output and optional I2C emulation
- two 8-bit multifunctional I/O ports
- one 4-bit port working as digital or analog inputs
- one 2-bit I/O port with optional address latch enable function

- **P-SDIP 52 package**

- **5 V supply voltage**

(3) Block Diagram

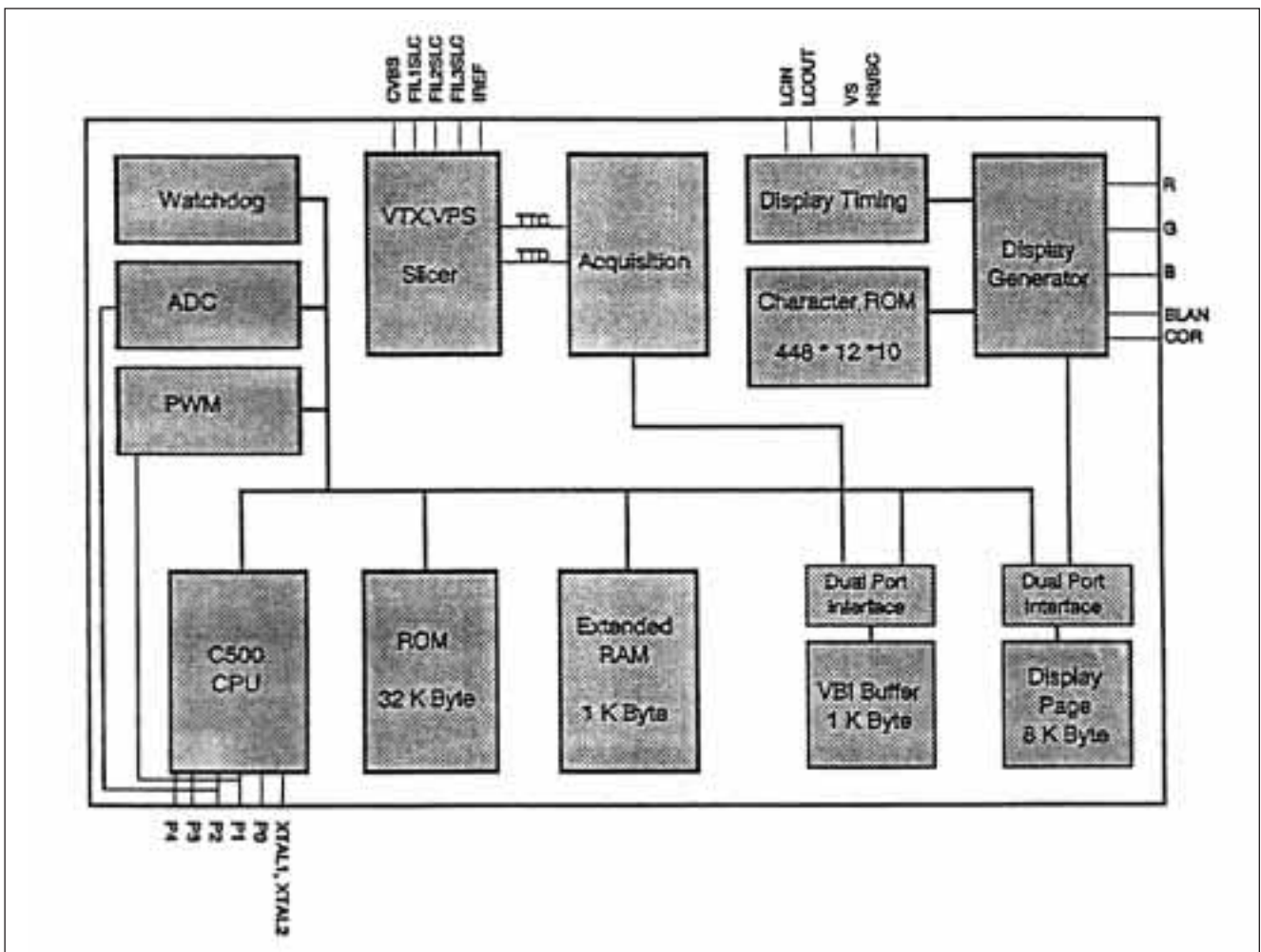

(4) Pin Description

* A : DW5255M*/DW5255RM*, *B : DW370ASM*

Pin		Name		Symbol	Description	
A*	B*	A*	B*		A*	B*
1	1	P3.1	T1IC1/CR	SYS	NTSC OUT for switching SAW filter K6259 - PAL/SECAM : L - NTSC : H	
2	2	P0.7/Open Drain	A0	BUSSTOP	I2C BUS STOP IN for Computer controlled alignment in Factory (Active Low)	
3	3	P0.6/Open Drain	A1	SDA	Serial data IN/OUT for I2C	
4	4	P0.5/Open Drain	A2	SCL	Serial clock IN/OUT for I2C	
5	5	P0.4/Open Drain	A3	OPTION	#5 #6 Teletext	#6
6	6	P0.3/Open Drain	A4	OPTION	H H West Teletext L H East Teletext H L Turkish Teletext	H : STAND-BY L : POWER ON
7	7	P0.2/Open Drain	A5	OPTION	Not Used	
8	8	P0.1/Open Drain	PWM1-0/ Open Drain	OPTION	Not Used	
9	9	P0.0/Open Drain	PWM1-1/ Open Drain	LED	LED drive OUT - Stand-by mode : H - Operating mode : L (IR reception : pulse)	
10	10	VSS		VSS	ground	
11	11	VCC		VCC	Power Supply	
12	12	XTAL1	OSCIN	OSCIN	Input to inverting osc. Amplifier	
13	13	XTAL2	OSCOOUT	OSCOOUT	Output of inverting osc. Amplifier	
14	14	P4.0/ALE	PWM1-2/Open Drain		Not Used	H : I/M, L : B/D
15	15	RESET	RESET/Open Drain	RST	RESET IN (ACTIVE LOW)	
16	16	P1.7/14BIT PWM	PWM2-0	VT	TUNING VOLTAGE OUT	
17	17	P1.6/14BIT PWM	PWM2-1	SW	H : I/M L : B/D	Not Used
18	18	P1.5/8BIT PWM	PWM1-3/Open Drain	F/SW	Not Used	
19	19	P1.4/8BIT PWM	PWM1-4/Open Drain		Not Used	
20	20	P1.3/8BIT PWM	PWM1-5/Open Drain	MUTE	AUDIO MUTE OUT	
21	21	P1.2/8BIT PWM	TEST	GND	(Must be tied 0V for DW370M*)	
22		P1.1/8BIT PWM			Not Used	
23		P1.0/8BIT PWM			Not Used	
24		VSSA		VSSA	Analog GND for Slicer	
25		FIL3		FIL3	PLL Loop Filter I/O for Phase Shifting	
26		FIL2		FIL2	PLL Loop Filter I/O for TTX Slicing	
27		FIL1		FIL1	PLL Loop Filter I/O for VPS Slicing	
28		VCCA		VCCA	Analog Supply for Slicer	
29		IREF		IREF	Reference Current for Slicer PLLs	

Pin		Name		Symbol	Description	
A*	B*	A*	B*		A*	B*
30		CVBS		CVBS	CVBS IN	
31		P2.3/8 bit ADC			Not Used	
32	22	P2.2/8 bit ADC	B0/AN0/ADC	AGC	IF AGC INPUT for Auto Tuning System	
33	23	P2.1/8 bit ADC	B1/AN1/ADC	KS	Local KEY SCAN IN	
34	24	P2.0/8 bit ADC	B2/AN2/ADC	S/SW	Not Used	
35	25	VSS	VSS-OSD	VSS	Ground	
36	26	P3.3/INT1	INT1	IR	REMOTE IR IN	
37	27	VDD	VCC-OSD	VDD	Power Supply	
38	28	LCIN	OSCIN-OSD	LCIN	CLOCK IN for OSD	
39	29	LCOUT	OSCOUD-OSD	LCOUT	CLOCK OUT for OSD	
40	30	P3.7/TXT I/O	T2EVT/PWM2	BL	BAND VHF-L OUT (Active High)	
41	31	P3.6/RXD	T2IC2/PWM1	BH	BAND VHF-H OUT (Active High)	
42	32	P3.5/T1	T2IC1/CR	BU	BAND UHF OUT (Active High)	
43	33	P3.4/T0	T1EVT/PWM2	POWER	POWER CONTROL OUT	
44	34	P3.2/INT0	INT2		Not Used	
45	35	HS/SC	HSYNC	HSYNC	HOR. SYNC. IN (Active High)	
46	36	P4.7/VS	VSYNC	VSYNC	VERT. SYNC. IN (Active High)	
47	37	R		R	RED OUT	
48	38	G		G	GREEN OUT	
49	39	B		B	BLUE OUT	
50	40	BLANK		BL	BLANK OUT	
51	41	COR		COR	Not Used (CONTRAST REDUCTION OUT)	
52	42	P3.0	T1C2/PWM1	EVEN/ODD	EVEN/ODD OUT for non-interlacing in TTX mode	

24LC08B (EEPROM)

(1) Features

- Single supply with operation down to 2.5V
- Low power CMOS technology
 - 1mA active current typical
 - 10 μ A standby current typical at 5.5V
 - 5 μ A standby current typical at 3.0V
- Organized as two or four blocks of 256 bytes (2x256x8) and (4x256x8)
- Two wire serial interface bus, I²C™ compatible
- Schmitt trigger, filtered inputs for noise suppression
- Output slope control to eliminate ground bounce
- 100KHz(2.5V) and 400KHz(5V) compatibility
- Self-timed write cycle(including auto-erase)
- Page-write buffer for up to 16 bytes
- 2ms typical write cycle time for page-write
- Hardware write protect for entire memory
- Can be operated as a serial ROM
- Factory programming(QTP) available
- ESD protection > 4,000V
- 1,000,000 ERASE/WRITE cycles(typical)
- Data retention > 40 years
- 8-pin DIP, 8-lead or 14-lead SOIC packages
- Available for extended temperature ranges
 - Commercial : 0° C to +70° C
 - Industrial : -40° C to +85° C

(2) General Description

The Microchip Technology Inc. 24LC08B is a 8K-bit Electrically Erasable PROM.

The device is organized as four blocks of 256x9bit memory with a two wire serial interface. Low voltage design permits operation down to 2.5 volts with standby and active currents of only 5 μ A and 1mA respectively.

The 24LC08B also has a page-write capability for up to 16 bytes of data.

The 24L08B is available in the standard 8-pin DIP surface mount 80IC packages.

(3) Block Diagram

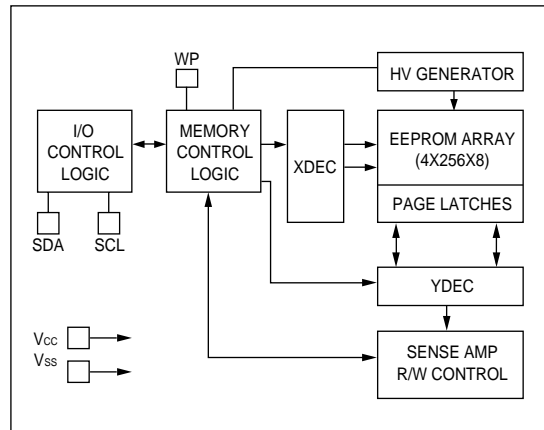

(4) Pin Description

PIN	SYMBOL	DESCRIPTION
1-3	A0, A1, A2	Device Address Inputs
4	Vss	Ground
5	SDA	Serial Data/Address
6	SCL	Serial Clock
7	WP	
8	Vcc	+5V Power supply

TDA8374A (Single chip TV Processor for Negative modulation IF)

TDA8374 (Single chip TV Processor for Negative & positive modulation IF)

(1) General Description

The TDA8374(A) is I2C-bus controlled single chip TV processors which are intended to be applied in PAL/NTSC television receiver.

The IC is mounted in a S-DIL 56 envelope.

(2) Feature

• IF

- Vision IF amplifier with high sensitivity and good figures for differential phase and gain
- PLL demodulator with high linearity offering the possibility for (single standard) intercarrier stereo audio application .
- Alignment PLL via I2C
- [TDA8374] Multistandard IF with negative and positive modulation, switchable via I2C

• AUDIO

- Alignment free multi standard PLL audio demodulator (4.5 to 6.5 MHz.)
- Mono volume control

• Video

- Integrated luminance delay line
- Integrated chroma trap and bandpass filters (auto calibrated)
- Asymmetrical peaking circuit in the luminance channel
- Black stretching of non standard CVBS or luminance signals

• Colour

- SECAM interface for application with SECAM add-on TDA8395.

• RGB

- RGB control (brightness, contrast, saturation)
- Black current stabilization and white point adjustment

• Input / Output

- Flexible video source select with CVBS input for the internal signal and two external video inputs(one switchable for CVBS or Y/C).
- The output signal of the video source select is externally available (also as CVBS when Y/C input is used).
- External audio input.
- Linear RGB input with fast blanking.

• Synchronization and Deflection

- Horizontal synchronization with two control loops and alignment free horizontal oscillator.
- Slow start and slow stop of the horizontal drive output to enable low stress start-up and switch-off from the line circuit at nominal line supply voltage.
- Vertical count-down circuit for stable behavior with provisions for non-standard signals.
- Vertical geometry control.
- Vertical drive optimized for DC coupled vertical output stages.

• Control

- Full I2C bus control, as well for customer controls as for factory alignment.
- All automatic controls have an option for forced mode.

• Power consumption

- Low power consumption (900 mW at 8.0 Volts).

• Packaging

- SDIL-56 (Shrunked Dual In Line, 56 pins).

(4) Pin Description

No	Name	Description
1	SOUND IF INPUT	The sound equivalent input impedance is 8k5 ohm // 5pF which has to be taken into account for proper termination of the ceramic filters. The DC impedance is very high. The minimum input signal for catching is 1 mV rms.
2	EXT AUDIO INPUT	An external sound signal (500mVrms) for example from SCART can be applied to this pin via a coupling capacitor. The input impedance is 25kohm.
3 4	VCO REF FILTER	The IF VCO tuned circuit is applied to these pin. Its resonance frequency must be two times the IF-frequency and in between a range of 64-120MHz. This range is suitable for the IF standards as 33.4, 38.9, 45.75 and 58.75MHz. The VCO frequency can be adjusted by I2C bus so a fixed coil can be used.
5	PLL LOOP FILTER	The PLL loopfilter is a first order filter with R=390 ohm and C = 100nF in series to ground. The loopfilter bandwidth is 60kHz and is optimal for both fast catching and sufficient video suppression for optimal sound performance. Sound performance can theoretically be improved by adding a small capacitor (approx.0- 4.7nF) between pin 5 and ground. This however must be evaluated further because the normal video signal response should not be effected.
6	IF VIDEO OUTPUT	Although the video output impedance is low it is recommended to avoid high frequency current in the output due to for instance sound trap filters. This can be achieved by means of an emitter follower at the video output with a 1 kΩ resistor in series with the base.
7	BUS INPUT : SCL	Serial clock line
8	BUS INPUT : SDA	Serial data line
9	BANDGAP DECOUPLING	The bandgap circuit provides a very stable and temperature independent reference voltage. This reference voltage (6.7V) ensures optimal performance of the TDA8374 and is used in almost all functional circuit blocks.
10	CHROMA INPUT	The supplied C S-VHS input burst amplitude should be nominally 300mVpp (assumed is a colour bar signal with 75% saturation and with chroma/burst ratio of 2.2/1). The C S-VHS input is internally clamped to 4V via 50 kΩ. The external AC coupling capacitor with 50 kΩ forms a high pass filter. A recommended coupling capacitor is 1 nF; the high pass filter cut off frequency is then approximately 3KHz.
11	Y/CVBS INPUT	The Y S-VHS signal of 1Vpp (inclusive sync amplitude) is AC coupled to pin11.
12 37	MAIN POSITIVE SUPPLY	The TDA8374 has a main supply pin 12 and a horizontal supply pin 37. Both pins have to be supplied simultaneously. Notice that the IC has not been designed to use this pin 37 as start pin. (pin 37 supplies the horizontal oscillator, PHI-1 and PHI-2) (pin 12 supplies the rest of the circuits in the IC) The nominal supply voltage is 8V. With min/max values of 7.2-8.8V. Also in stand-by condition the IC must be supplied with 8V.

No	Name	Description
		to the luminance input pin 27. The pin is internally AC coupled to the luminance clamp via a capacitor of 50pF; clamping action occurs during burstkey period.
28	LUMINANCE OUTPUT	The luminance output signal is approximately 1 V black-white with typical output impedance of 250 ohm.
29 30	B-Y OUTPUT R-Y OUTPUT	The maximum output impedance of pins 29 and 30 is 500 Ω when PAL/NTSC signals are identified. When SECAM is identified by the SECAM add-on and no PAL/NTSC is already identified by the ASM, then the ASM sets the -(B-Y)/-(R-Y) output switch open (via DEMSW). This enables the -(B-Y)/-(R-Y) outputs of the TDA8395 to be directly connected to pins 29 and 30 respectively.
31 32	B-Y INPUT R-Y INPUT	The -(B-Y),-(R-Y) output signals (supplied from baseband delay line) are AC coupled, via a coupling capacitor of 10nF or greater, to the -(B-Y)/-(R-Y) inputs; both inputs are clamped during burstkey period.
33	SECAM REF OUTPUT	The SECAM reference output is directly connected to pin I of the TDA8395 for SECAM decoding ; it also can be used as a reference for comb filter applications.
34 35	X-TAL 3.58 X-TAL 4.43	To ensure correct operation of both: - colour processing internal circuits, - sync calibration internal circuits, it is only allowed to have 3.6MHz Xtals on pin34: both 4.4MHz,3.6MHz Xtals are allowed on pin 35. If pin 35 is not used: then it is left open in application (also XA,XB=O,1).
36	LOOP FILTER BURST PHASE DETECTOR	One of the important aspects of the PLL is the loop filter connected to pin 36; it influences the dynamic performance of the loop.
38	CVBS OUTPUT	The output amplitude is 1Vpp (transfer gain ratio between CVBS1int or CVBS2ext or CVBS3ext/Ys-vhs and CVBSout is 1). The maximum output impedance is 250 ohm.
39	BLACK PEAK HOLD CAPACITOR	For the correct working of the black stretcher an external time constant should be added at the black peak hold capacitor input.
40	HOR OUTPUT	This open collector output is meant to drive the horizontal output stage. The output is active low, i.e. the line transistor should conduct during the low period of the output.
41	SANDCASTLE OUTPUT/ FLYBACK INPUT	Pin 41 is a combined input/output pin. The pin provides a three level sandcastle pulse. Both burstkey pulse and vertical blanking pulse are always available, the line blanking pulse is only present when the external flyback pulse is fed to this pin. The line flyback pulse, fed to this pin is used for two functions: - input signal for the PHI-2 loop and - RGB line blanking. (without flyback pulse blanking occurs only during the burstkey pulse) To ensure correct working of the delay line and SECAM add-on, the output should not be loaded with more than: - Sandcastle input delay line TDA 4665 - Sandcastle input SECAM add-on TDA 8395
42	PHI-2 FILTER / FLASH PROTECT	The loopfilter is a first order filter. This pin requires a capacitor (C) only.

No	Name	Description
		A flash protection becomes active when this pin is forced >6V. The horizontal drive is switched-off immediately. Once the voltage is <6V the horizontal drive is switched-on again via the slow start procedure.
43	PHI-1 FILTER	The loopfilter connected to pin 43 is suitable for various signal conditions as strong/weak and VCR signal. This is achieved by switching of the loopfilter time constant by changing the PHI-1 output current. Via I2C bus FOA/B, different time constants can be chosen, including an automatic mode which gives optimal performance under varying conditions.
44	GROUND	To this pin are connected the IC-substrate and horizontal output.
45	EAST-WEST DRIVE	not used
46 47	VERT DRIVE + VERT DRIVE -	The vertical drive has a current output. The output is balanced which ensures a good common mode behavior with temperature and makes the output signal less sensitive for disturbances.
48 49	IF INPUT	The PLL frequency range is 32-60MHz with corresponding VCO frequency 64-120MHz. The IF input impedances is 2k Ω in parallel with 3pF and matches the required load for commonly used SAW filters. A DC coupling is allowed, so no series capacitors between SAW filter and IF input are necessary.
50	EHT/OVERVOLTAGE PROTECT INPUT	not used
51	VERT SAWTOOTH CAPACITOR	This pin requires a capacitor to ground of 100nF +, - 5%. The optimal sawtooth amplitude is 3.5V and is determined by the external capacitor and charge current. The sawtooth bottom-level is 2V.
52	REFERENCE CURRENT INPUT	This pin requires a resistor to ground. The optimal reference current is 100 μ A. which is determined by this resistor.
53	AGC DECOUPLING CAPACITOR	The AGC capacitor value is 2.2 μ F and has been defined for an optimal compromise between AGC speed and tilt for all AGC modes (negative/positive modulation).
54	TUNER AGC OUTPUT	This output is used to control (reduce) the tuner gain for strong RF signals. The tuner AGC is an open collector output which is acting as a variable current source to ground.
55	AUDIO DEEMPHASSIS	Only a capacitor has to be connected to this pin that defines the deemphasis time constant. The signal is internally connected through to the Audio switch. The deemphasis output is fixed, thus not controlled by the volume, and can be used for SCART.
56	DECOUPLING SOUND DEMODULATOR	This pin requires a capacitor of 10 μ F connected to ground. The pin acts as a low pass filter needed for the DC feedback loop.

TDA4665(Base Band Delay Line)

(1) Features

- Two comb filters, using the switched-capacitor technique, for one line delay time (64µs)
- Adjustment free application
- No crosstalk between SECAM colour carriers
- Handles negative or positive colour-difference input signals
- Clamping of AC-coupled input signals(±(R-Y)and±(B-Y))
- VCO without external components
- 3MHz internal clock signal derived from a 6MHz VCO, line-locked by the sandcastle pulse (64µs line)
- Sample-and-hold circuits and low-pass filters to suppress the 3 MHz clock signal
- Addition of delayed and non-delayed output signals
- Output buffer amplifiers
- Comb filtering functions for NTSC colour-difference signals to suppress cross-colour

(2) General Description

The TDA4661 is an integrated baseband delay line circuit with one line delay. It is suitable for decoders with colour-difference signal outputs±(R-Y)and±(B-Y).

(3)Block Diagram

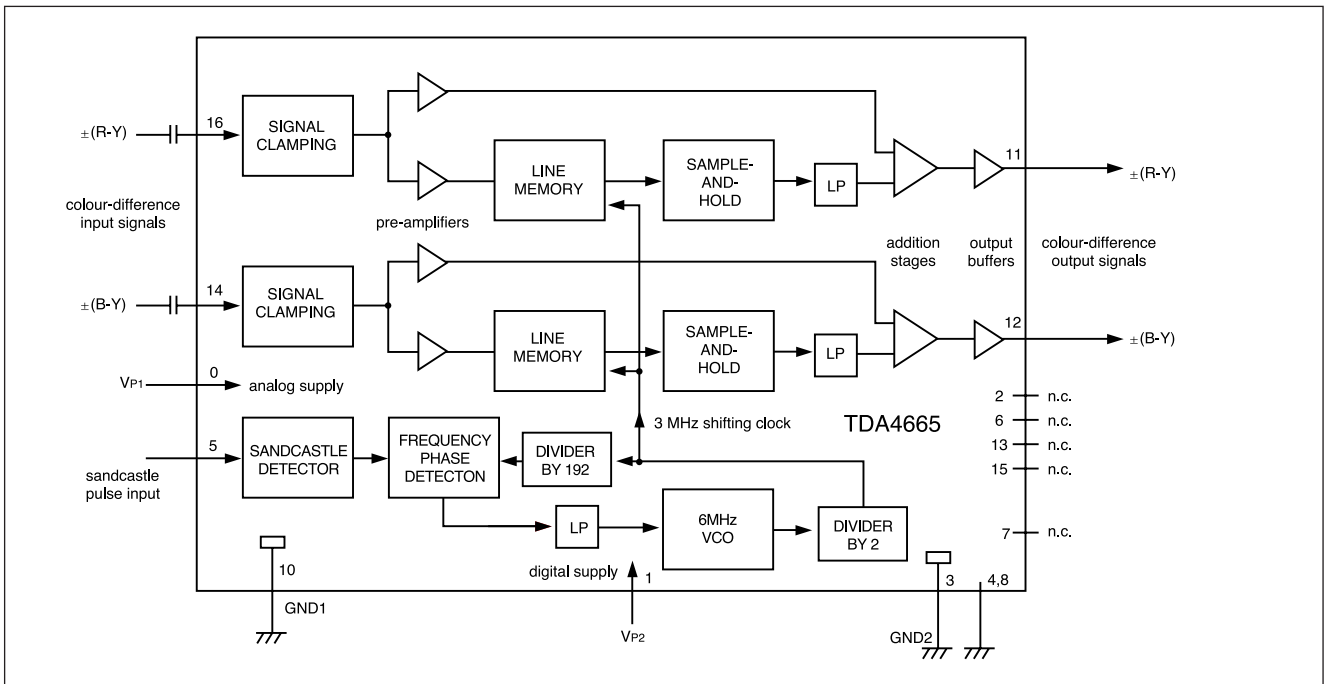

(4) Pin Description

SYMBOL	PIN	DESCRIPTION
V _{p2}	1	+5V supply voltage for digital part
n.c.	2	not connected
GND2	3	ground for digital part (0V)
i.c.	4	internally connected
SAND	5	sandcastle pulse input
n.c.	6	not connected
i.c.	7	internally connected
i.c.	8	internally connected

SYMBOL	PIN	DESCRIPTION
V _{p1}	9	+5V supply voltage for analog part
GND1	10	ground for analog part (0V)
V ₀ (R-Y)	11	± (R-Y) output signal
V ₀ (B-Y)	12	± (B-Y) output signal
n.c.	13	not connected
V ₁ (B-Y)	14	± (B-Y) input signal
n.c.	15	not connected
V ₁ (R-Y)	16	± (R-Y) input signal

TDA8395 (Secam Decoder)

(1) Features

- Fully integrated filters
- Alignment free
- For use with baseband delay

(2) Description

The TDA8395 is a self-calibrating, fully integrated SECAM decoder. The IC should preferably be used in conjunction with the PAL/NTSC decoder TDA8362 and with the switch capacitor baseband delay circuit TDA4665. The IC incorporates HF and LF filters, a demodulator and an identification circuit (luminance is not processed in this IC).

A highly stable reference frequency is required for calibration and a two-level sandcastle pulse for blanking and burst gating.

(3) Block Diagram

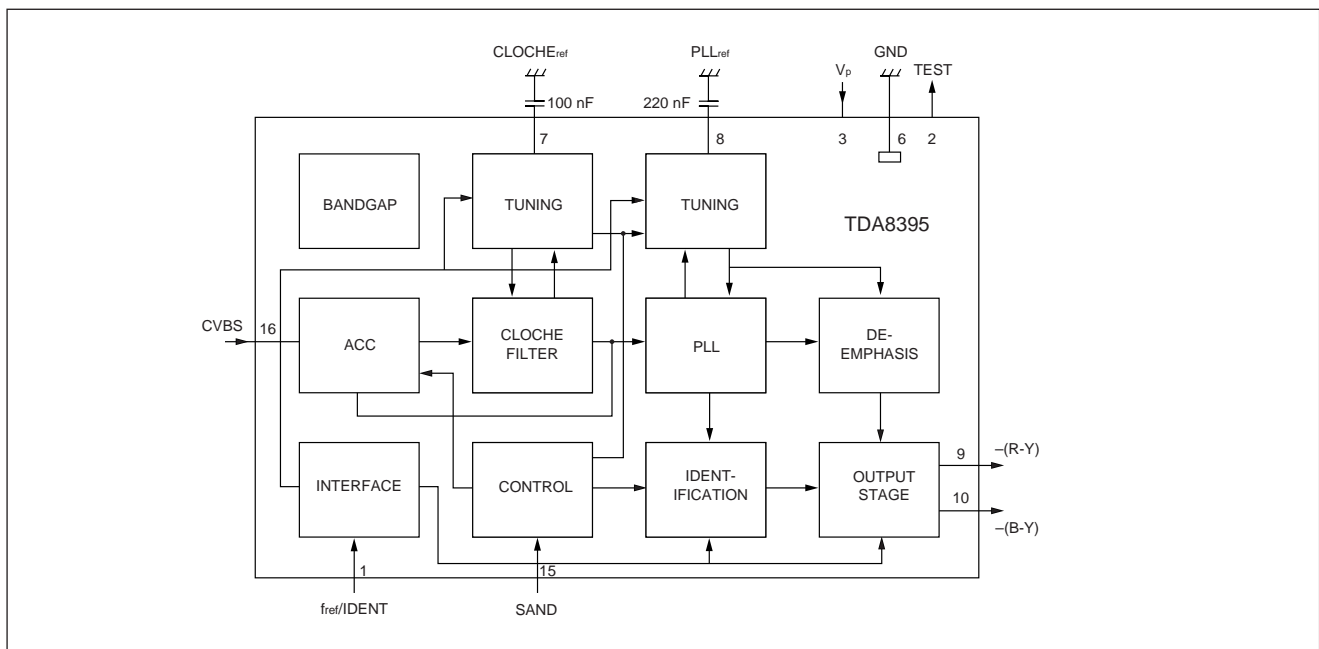

(4) Pin Description

SYMBOL	PIN	DESCRIPTION
f _{p1} /IDENT	1	reference frequency input/identification input
TEST	2	test output
V _p	3	positive supply voltage
n.c.	4	not connected
n.c.	5	not connected
GND	6	ground
CLOCHE _{ref}	7	Cloche reference filter
PLL ref	8	PLL reference
-(R-Y)	9	-(R-Y) output
-(B-Y)	10	-(B-Y) output
n.c.	11	not connected
n.c.	12	not connected
n.c.	13	not connected
n.c.	14	not connected
SAND	15	sandcastle pulse input
CVBS	16	video (chrominance) input

TDA6106Q (Video Output Amplifier)

(1) General Description

The TDA6106Q is a monolithic video output amplifier (5MHz bandwidth) in a SIL 9 MPpackage, using high-voltage DMOS technology, and is intended to drive the cathode of CRT directly .

To obtain maximum performance, the amplifier should be used with black-current control.

(2) Feature

- Black - current measurement output for automatic black current stabilization (ABS)
- Single supply voltage of 200V
- Internal protection against positive appearing CRT flash-over discharge
- Protection against ESD
- Internal 2.5V reference circuit
- Controllable switch-off behavior

(3) Block Diagram

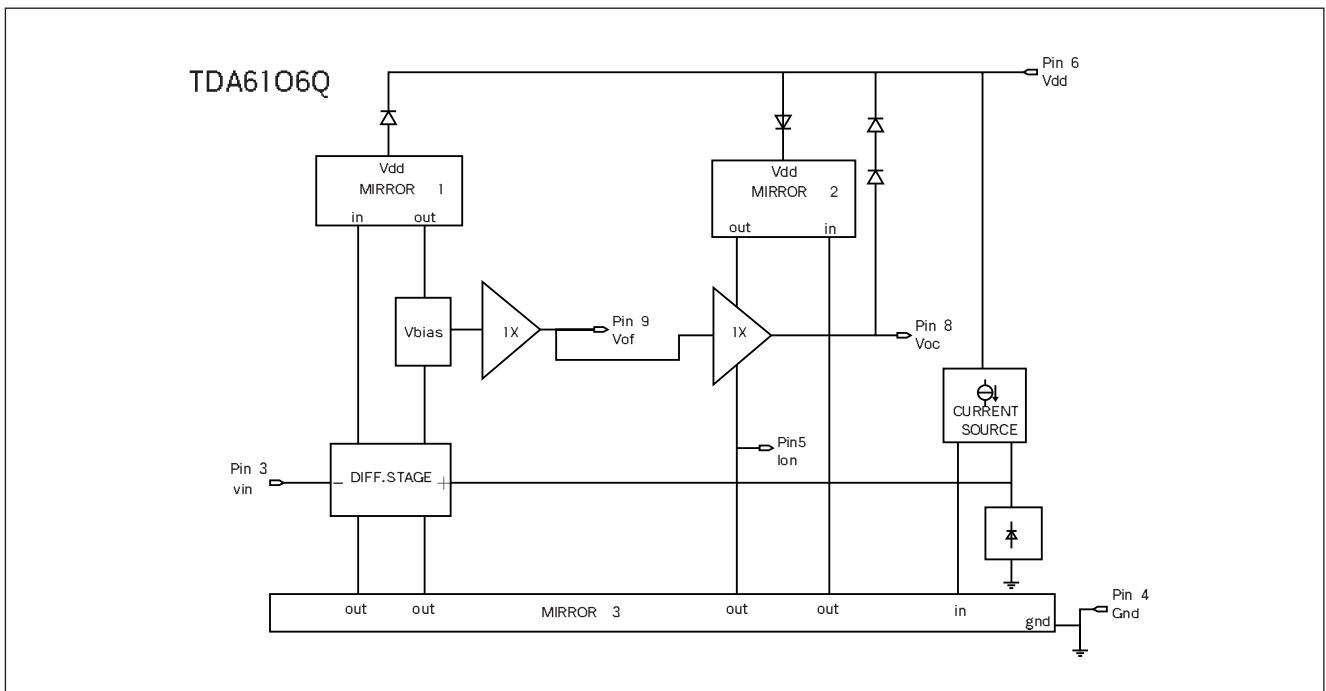

(4) Pin Description

PIN	SYMBOL	DESCRIPTION
1		N.C
2		N.C
3	V in	inverting input
4	GND	ground, substrate
5	I om	Black-current measurement output
6	V dd	supply voltage high
7		N.C
8	V oc	cathode output
9	V of	feedback/transient output

I802 PC817

(1) General Description

The specification applies to the structures and characteristics of Model No. PC817

(2) Block Diagram

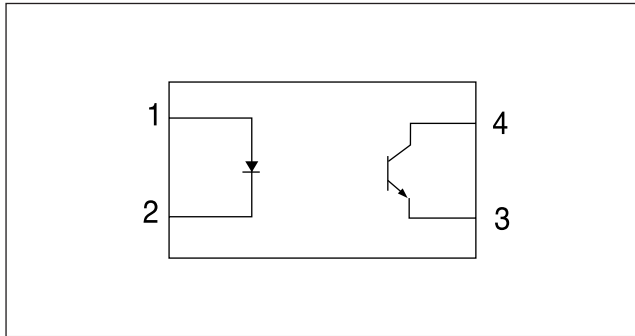

(3) Absolute maximum ratings

	Parameter	Symbol	Rating	Unit
Input	Forward current	IF	50	mA
	*1) Peak forward current	IFM	1	A
	Reverse voltage	VR	6	V
	Power dissipation	P	70	mW
Output	Collector-emitter voltage	VCEO	35	V
	Emitter-collector voltage	VECO	6	V
	Collector current	IC	50	mA
	Collector power dissipation	Pc	150	mW
Total Power dissipation		Ptot	200	mW
Operating temperature		Topr	-30~+100	°C
Storage temperature		Tstg	-55~+125	°C
*2) Isolation voltage		Viso	5	kVrms
*3) Soldering temperature		Tsol	260	°C

*1) Pulse width $\leq 100\mu\text{s}$, duty ratio: 0.001

*2) AC for 1 minute, 40~60% RH

*3) For 10 seconds.

TDA8356 (DC-coupled vertical deflection circuit)

(1) General Description

The TDA8356 is power circuit for use in 90° and 110° color deflection systems for field frequencies of 50 to 120 Hz. The circuit provides a DC driven vertical deflection output circuit, operating as a high efficient class G system.

(2) Feature

- High efficient fully DC-coupled vertical output bridge circuit
- Vertical fly-back switch
- Guard circuit
- Protection against : - short circuit of the output pins (7 and 4)
- short circuit of the output pins to V_p
- Temperature (thermal) protection
- High EMC immunity because of common mode inputs

(3) Block Diagram

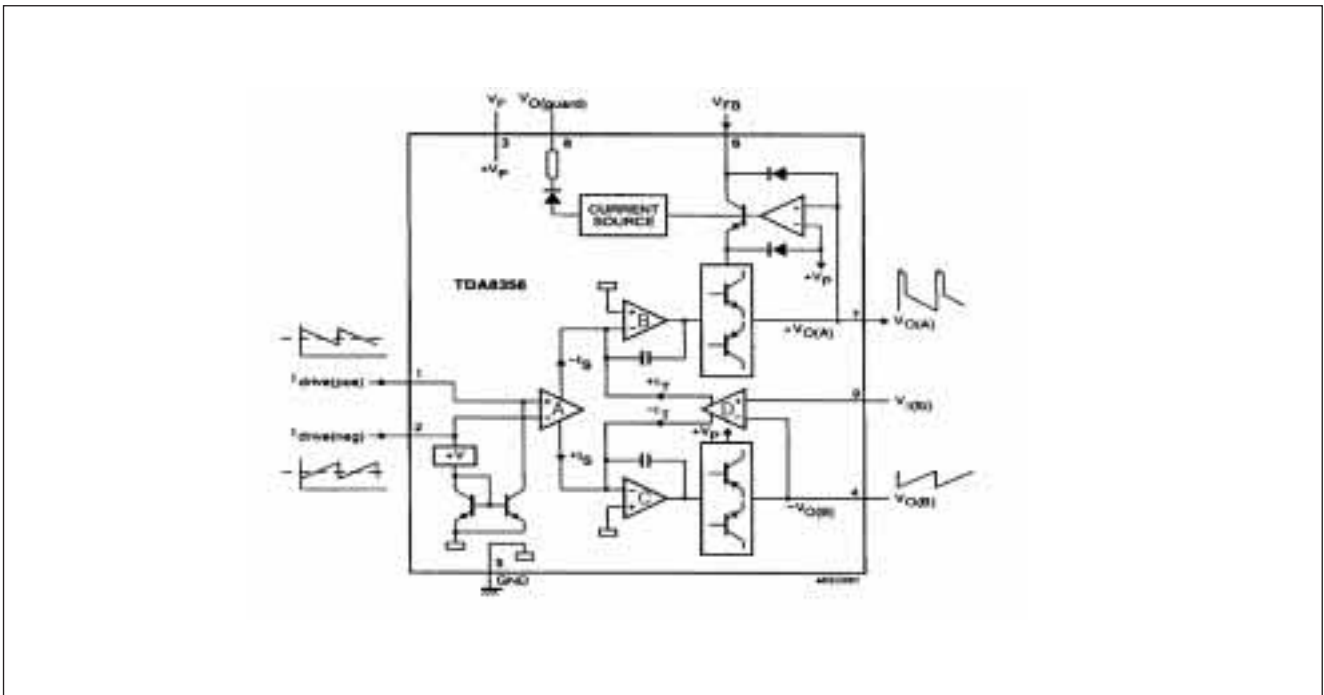

(4) Pin Description

PIN	SYMBOL	DESCRIPTION
1	I drive (pos)	input power stage (positive); include Ii(sb) signal bias
2	I drive (neg)	input power stage (negative); include Ii(sb) signal bias
3	V p	operating supply voltage
4	V o(b)	output voltage B
5	GND	ground
6	V fb	input fly-back supply voltage
7	V o(a)	output voltage A
8	V o(guard)	guard output voltage
9	V I(fb)	input feedback voltage

TDA7056 (BTL AUDIO OUTPUT AMPLIFIER) : 1 SPEAKER MODEL

(1) Features

- No external components
- No switch-on/off clicks
- Good overall stability
- Low power consumption
- Short circuit proof
- ESD protected on all pins

(2) General Description

The TDA7056 is a mono output amplifier contained in a 9 pin medium power package. The device is designed for batteryfed portable mono recorders, radios and television.

(3)Block Diagram

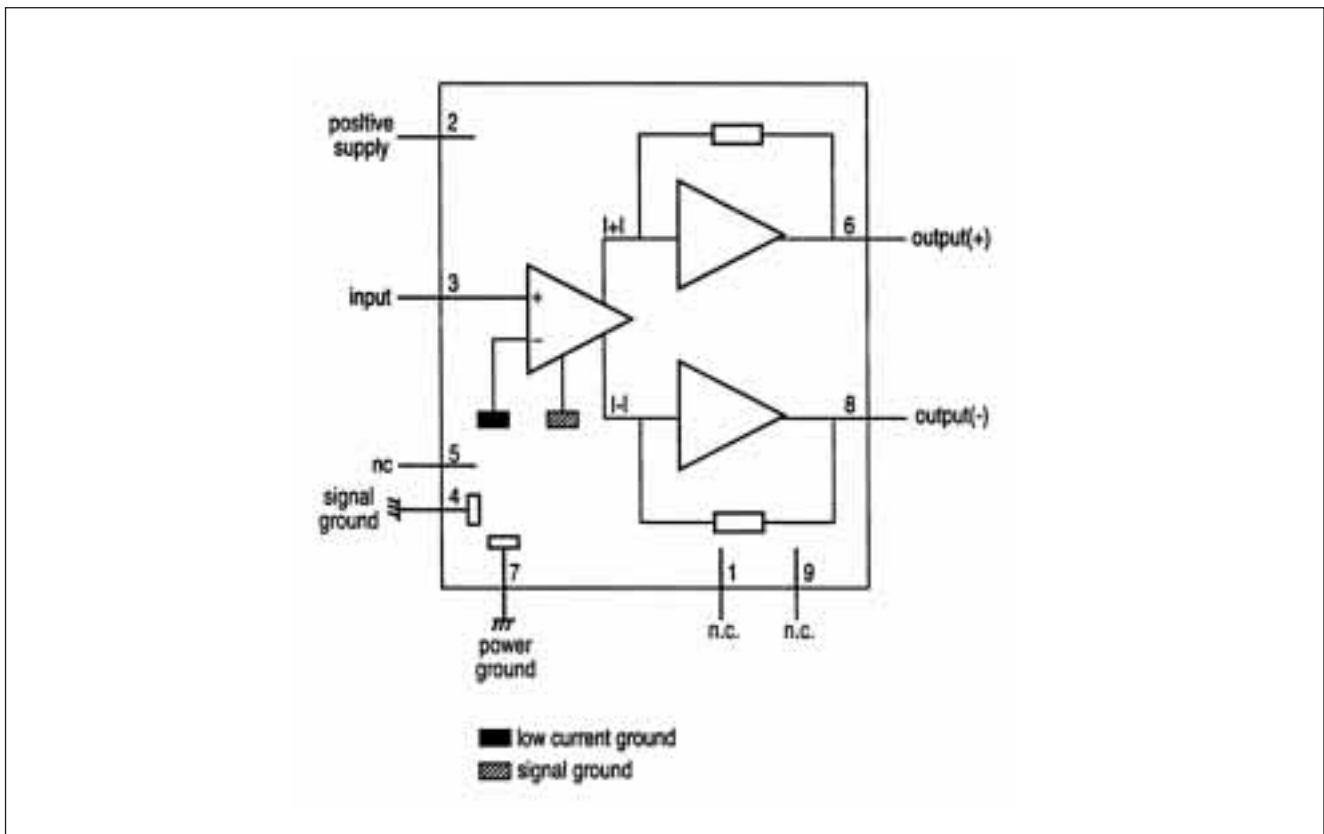

(4)Pin Description

PIN	DESCRIPTION
1	n.c.
2	Vp
3	input (+)
4	signal ground
5	n.c.
6	output (+)
7	power ground
8	output (-)
9	n.c.

STR-S5707 (Hybrid IC for a Switching Regulator)

(1) General Description

The STR-S5707 is a Hybrid IC with a built in power transistor and a separate excitation control IC, designed for converter type switching mode power supply applications. The IC is capable of quasi-resonant mode and requires small number of external component.

(2) Feature

- Small SIP isolated package : Resin sealed type (transfer mold)
- Lower power dissipation at a lighter load
- Many protection function : - Pulse-by-pulse over current protection
 - Over-voltage protection with a latch
 - Thermal protection with a latch
- These protection functions are incorporated and can be latched with an external signal.

(3) Block Diagram

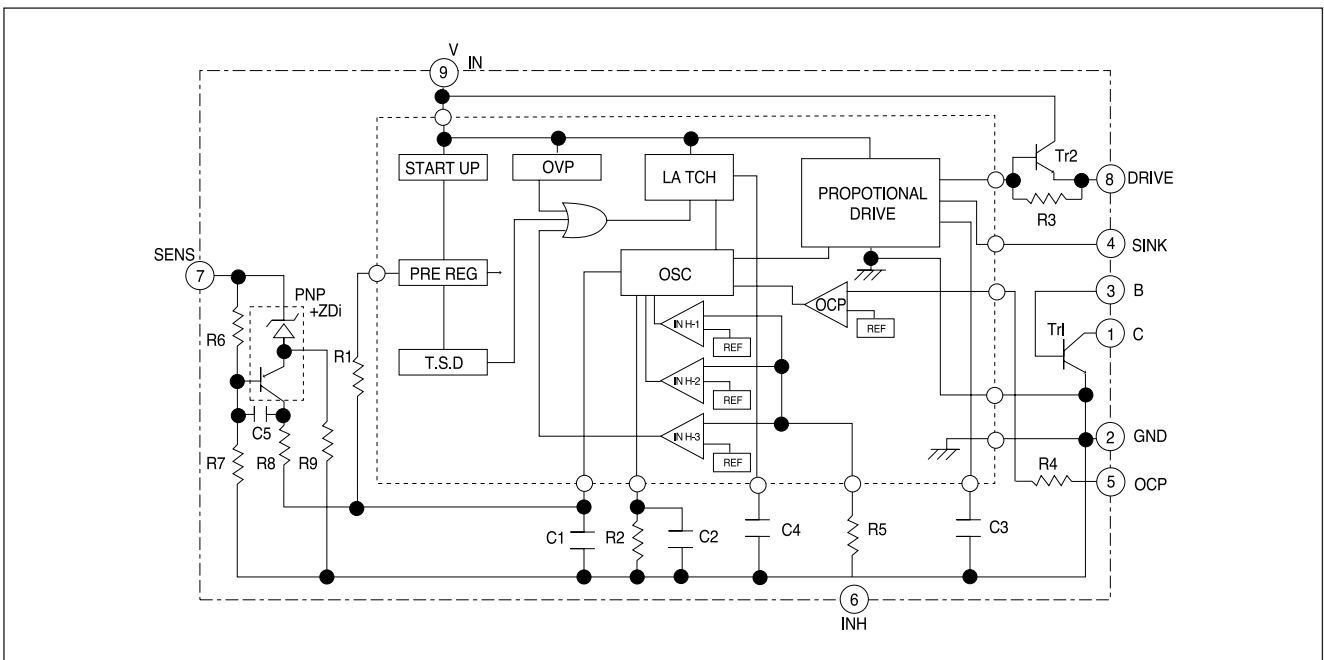

(4) Pin Description

PIN	NAME	SYMBOL	DESCRIPTION
1	Collector	C	Collector of power Tr
2	Ground	GND	ground (Emitter of power Tr)
3	Base	B	Base of power Tr
4	Sink	SINK	Base current (IS) input
5	Over-current protection	OCP	over-current sensing signal input
6	Inhibit Latch	INH	input for synchronizing OFF time and latch circuit operation
7	Sensing	SENS	constant voltage control signal input
8	Drive	DRIVE	Base drive current (ID) output
9	Vin	VIN	supply voltage for control circuit

Electrical Characteristics of Control Part (Ta=25℃)

Description	Terminal	Symbol	Rating			Unit
			MIN	TYP	MAX	
On-state Voltage	9-2	V _{IN(ON)}	7.6	8	8.4	V
Off-state Voltage	9-2	V _{IN(OFF)}	4.6	4.9	5.2	V
Operating Circuit Current	9-2	I _{IN(ON)}	15	—	28	mA
Stand-by Circuit Current	9-2	I _{IN(OFF)}	—	—	200	μA
On Time	—	T _{ON}	33	—	41	μsec
Off Time	—	T _{OFF}	45	—	55	μsec
OCP terminal Threshold Voltage	6-2	V _{OCP}	-1.12	-1	-0.88	V
INH terminal Threshold Voltage 1	8-2	V _{INH-1}	0.65	0.75	0.85	V
INH terminal Threshold Voltage 2	8-2	V _{INH-2}	—	1.4	2.0	V
INH terminal Threshold Voltage 3	8-2	V _{Latch}	3.2	5.1	5.8	V
OVP Operating Voltage	9-2	V _{IN(OVP)}	9.2	—	10.7	V
Latch Circuit Sustaining Current	9-2	I _H	—	—	500	μA
Latch Circuit Cancellation Voltage	9-2	V _{IN(La.OFF)}	2.5	3.1	—	V
MIC Thermal Shutdown Starting Temp	—	T _{j(TSD)}	125	150	—	℃
Fixed Reference Voltage	7-2	V _s	32.0±0.3			V
Temperature Coefficient of Reference Voltage	7-2	—	—	+2.5	—	mV/℃

Electrical Characteristics of Power Transistor Part(Trl) (Ta=25℃)

Description	Terminal	Symbol	Rating			Unit
			MIN	TYP	MAX	
Collector Saturation Voltage	1-2	V _{CE(sat)}	—	—	0.4	V
Collector Cutoff Current	1-2	I _{CEX}	—	—	100	μA
Base-Emitter saturation voltage	3-2	V _{BE(sat)}	—	—	1.5	V
DC Current Gain	—	h _{FE}	29	—	61	—
Thermal Resistance	—	θ _{j-F}	—	—	1.3	℃/W
Switching Time	1-2	t _s	—	—	15	μsec
	1-2	t _f	—	—	0.5	

TDA8138 (5.1V+12V regulator with Disable and Reset)

(1) General Description

The TDA8138 is a monolithic dual positive voltage regulator designed to provide fixed precision output voltages of 5.1V and 12V at currents up to 1A.

An internal reset circuit generates a reset pulse when the output 1 decreases below the regulated voltage value.

Output 2 can be disabled by TTL input.

Short circuit and thermal protections are included.

(2) Feature

- output currents up to 1A
- fixed precision Output 1 voltage $5.1V \pm 2\%$
- fixed precision Output 2 voltage $12V \pm 2\%$
- output 1 with Reset facility
- output 2 with Disable by TTL input
- short circuit protection at both outputs
- thermal protection
- low drop output voltage

(3) Block Diagram

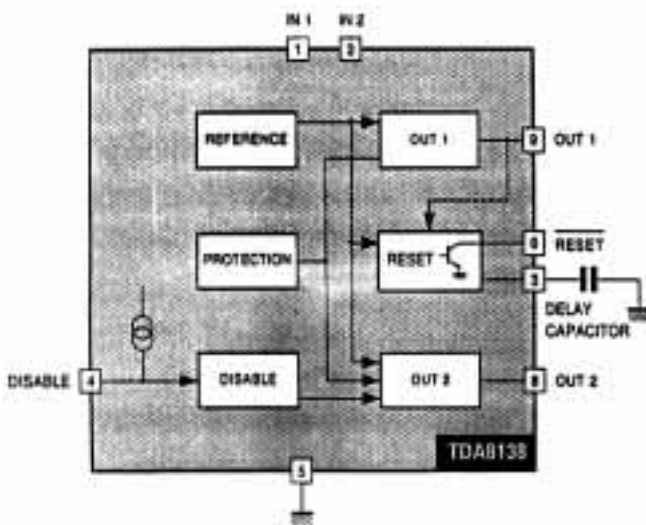

(4) Pin Description

PIN	SYMBOL	DESCRIPTION
1	V in 1	input 1
2	V in 2	input 2
3	C e	Delay capacitor
4	V dis	disable
5	GND	ground
6	RST	reset
7		n.c
8	V out 2	output 2 (12V)
9	V out 1	output 1 (5.1V)

TDA 1519B(AUDIO OUTPUT AMPLIFIER); 2 SPEAKER MODEL

(1) Features

- Requires very few external components for Bridge Tied Load(BTL)
- Stereo or BTL application
- High output power
- Low offset voltage at output (important for BTL)
- Fixed gain
- Good ripple rejection
- Mute/stand-by switch
- Load dump protection
- AC and DC short-circuit-safe to ground and Vp
- Thermally protected
- Reverse polarity safe
- Capability to handle high energy on outputs(Vp=OV)
- No switch-on/switch-off plop
- Protected against electrostatic discharge
- Identical inputs(inverting and non-inverting)
- Compatible with TDA 1519A(except output power)

(2) General Description

The TDA 1519B is an integrated class-B dual output amplifier in a 9-lead single in-line(SIL) plastic medium power package. The device is primarily developed for car radio applications.

(3) Block Diagram

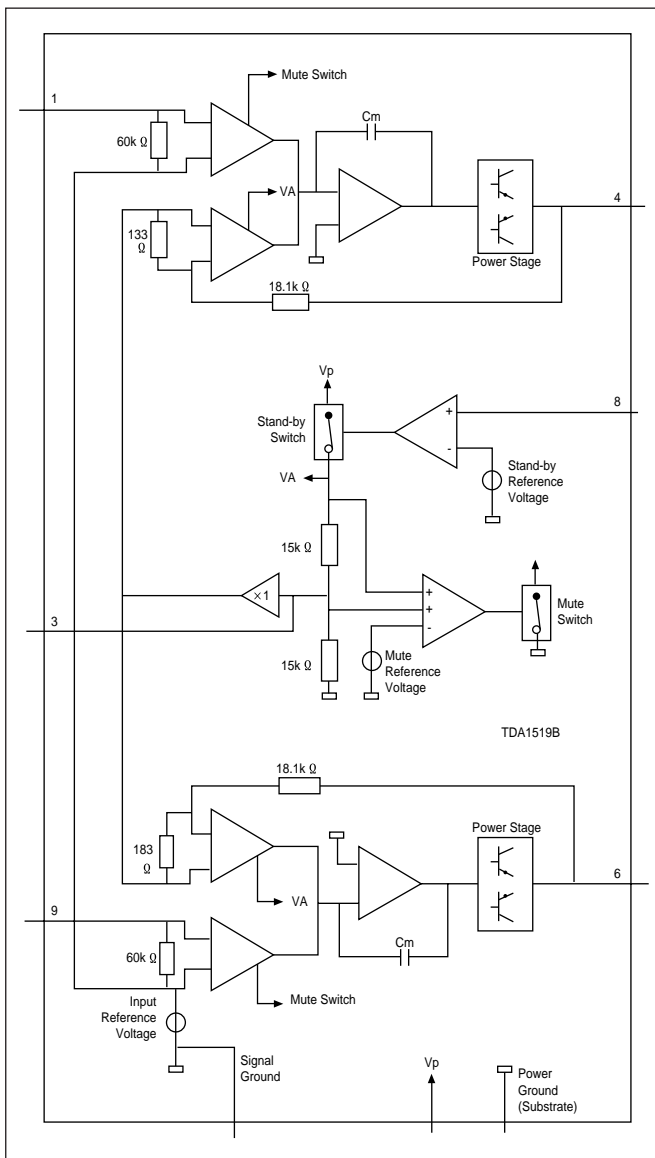

(4) Pin Description

PIN	SYMBOL	DESCRIPTION
1	NINV	non-inverting input
2	GND1	ground(signal)
3	RR	supply voltage ripple rejection
4	OUT1	output 1
5	GND2	ground(substrate)
6	OUT2	output 2
7	Vp	positive supply voltage
8	M/ss	mute/stand-by switch
9	INV	inverting input

PCA84C 122A(IC REMOCON)

(1) Features

- ROM, RAM and I/O is device dependent
- Two test inputs T0, T1
- 3 Single-level vectored interrupt sources
- 8 bit programmable timer/counter with 5-bit pre-scaler
- Single supply voltage from 2.0V to 5.5V
- On-board oscillator 1MHz to 5MHz
- Operating temperature range -20 to +50° C

(2) General Description

The PCA84C122A is a stand-alone micro controller designed for use in remote control unit for a wide range of applications.

(3) Pin Description

PIN	SIGNAL	DESCRIPTION
3	P00	Standard I/O Port lines, generally used for keypad scanning
2	P01	
23	P02	
22	P03	
10	P04	
11	P05	
14	P06	
15	P07	
19	P10	Standard I/O Port lines, generally used for keypad scanning
18	P11	
17	P12	
16	P13	
1	P14	
24	P15	
12	P16	
13	P17	
4	TP/INT	Test T0 and external interrupt input
5	T1	Test T1
6	RESET	Active HIGH reset, normally tied to Vss because internal Power-on reset can serve the same function
8	XTAL 1	Crystal or ceramic resonator
9	XTAL 2	
21	OUT	Pulse train output pin, capable of sinking 27mA
7	VDD	Power supply
20	Vss	Ground

■ Circuit Description

Vision IF amplifier, AFC, video demodulator

The IF signal from the tuner is fed through a SAW filter to the differential IF input (pin 48 and 49).

The first IF stage consists of 3 AC-coupled amplifiers with a total gain control range of over 66 dB.

The reference carrier for the video demodulator is obtained by a PLL carrier regenerator (eliminating notch filter compromises, as in reference tuned circuits for passive carrier regeneration).

Only an oscillator coil is needed (pin 3 and 4) that can be aligned via I2C-bus to the double IF frequency.

The AFC information is derived from the VCO control voltage of the IF-PLL and can be read via I2C-bus.

Bit AFB toggles when the picture carrier is exactly at the desired IF frequency (= half the aligned IF-PLL frequency).

AFA is active in a window around this point.

For fast search-tuning applications this window can be increased by a factor 3 (AFW bit).

Tuner A.G.C.

The automatic gain control (A.G.C.) circuit operates on top sync level at negative modulated signals or on peak white level at positive modulation, selected by MOD bit.

The tuner A.G.C. is controlled via pin 54.

The tuner A.G.C. take over point (T.O.P.) can be set over a wide range: 0.8 mVrms .. 80 mVrms IF input signal amplitude.

The tuner AGC output may have to operate above Vcc of TDA8374.

Therefore pin 54 is an open collector output, that can operate from 0.3 up to Vcc+ 1 Volt (at > 2 mA sink current)

PLL sound demodulator

The IF-video output at pin 6 (2Vpp) is fed through a sound bandpass filter and connected to the intercarrier sound IF input pin 1.

An alignment free PLL tunes itself to the sound carrier and demodulates it.

The non volume-controlled front-end audio signal can be obtained from the deemphasis pin 55 (amplitude 300 mVeff).

Source select switch

TDA8374 input switch can select one of the following sources ;

pin 13 front-end : CVBS I int

pin17 : CVBS 2 ext

pin 11.pinIO : Y s-vhs, C s-vhs

Selected signal is available at the CVBS output pin 38, in case of Y/C input Y+C are added.

It drive teletext and the TDA8395 SECAM add-on.

For S-VHS applications, the Y,C input can be selected, independent of the CVBS source switch.

TDA8374 Y,C inputs are selected, while the source switch outputs CVBS I int or CVBS 2 ext on CVBS out.

Horizontal synchronization and protection

The synchronization separator adapts its slicing level in the middle between top-sync and black level of the CVBS signal.

The separated synchronization pulses are fed to the first phase detector and to the coincidence detector.

The ϕ -1 loop gain is determined by the components at pin 43 (C+RC).

The coincidence detector detects whether the horizontal line oscillator is synchronized to the incoming video.

The line oscillator is a VCO-type, running at twice the line frequency.

It is calibrated with the X-tal oscillator frequency of the colour decoder and has a maximum deviation of 2% of the nominal frequency, so no alignment is-needed.

Calibration is done at start up(the TDA8374 must first know what colour X-tals are connected, bits XA and XB) and after synchronization loss (ϕ -1 coincidence detector "Sync Locked" bit SL).

The second phase detector ϕ -2 locks the phase of the horizontal driver pulses at output pin 40 to the horizontal flyback pulse at input pin 41 .

This compensates for the storage time of the horizontal deflection transistor.
 The ϕ - 2 loop filter (C) is externally connected to pin 42.
 The horizontal phase can be given a static off set via I2C-but (HSH "horizontal shift")
 A dynamic correction is possible by current feedback into the ϕ - 2 loop filter capacitor.

To protect the horizontal deflection transistor, the horizontal drive is switched off immediately when a power failure (" Power-On Reset " bit POR) is detected.
 The power failure may have corrupted the contents of the internal data registers, so the TDA8374 should be started up again.

The TDA8374 has a separate supply input (pin 37) that only used as a clean supply voltage for the horizontal oscillator circuits.

Vertical synchronization

The vertical sawtooth generator drives the vertical output.
 It uses an external capacitor at pin 51 and a current reference resistor at pin 52.
 The TDA8374 vertical drive has differential current outputs for DC-coupled vertical output stage, like the TDA8356 .
 At TDA8356 input pins 1 and 2 this current is converted into a drive voltage via a resistor.

Geometry processing

With the TDA8374 is possible to implement automatic geometry alignment, because all parameters are adjusted via the I2C bus.

The deflection processor of the TDA8374 offers the following five controls;

- Horizontal shift
- Vertical slope.
- Vertical amplitude
- Vertical S-correction
- vertical shift

Colour decoder

The colour decoder contains an alignment-free X-tal oscillator, a dual killer circuit and colour difference demodulators.
 Together with the TDA8395 SECAM add-on a multi standard PAL/SECAM/NTSC decoder can be built with automatic recognition.

Which standard can be decoded depends on the external Xtals used.

Two Xtal pins (34 and 36) are present so normally no external switching is required.

The I.C. must be told which X-tals are connected (bits XA and XB).

This is important, because the X-tal frequency of the colour decoder is also used to calibrate many internal circuit.

The burst phase detector locks the Xtal oscillator with the chroma burst signal.

The phase detector operates during the burst key period only, to prevent disturbance of the PLL by the chroma signal.

Two gain modes provide:

- Good catching range when the PLL is not Locked.
- Low ripple voltage and good noise immunity once the PLL has locked

The killer circuit switches-off the R-Y and B-Y demodulators at very low input signal conditions (chroma burst amplitude).

A hysteresis prevents on/off switching at low, noisy signals.

Color standard	pin34	pin35	XA	XB
PAL4.43/SECAM + NTSC-4.43	none	4.43	1	0
PAL4.43/SECAM + NTSC-M	3.58	4.43	1	1

Integrated video filters

The TDA8374 has alignment-free internal luminance delay, chroma bandpass and chroma trap. They are implemented as gyrator circuits tuned by tracking to the frequency of the chroma Xtal oscillator. The chroma trap in the Y signal path is by-passed when Y/C input is selected (S-VHS). For SECAM an extra luminance delay is build-in, for correct delay of the luminance signal.

RGB output and black current stabilization

The colour difference signals (R-Y, B-Y) are matrixed with the luminance signal (Y) to obtain the RGBout output signals (pins 21,20,29).

In the TDA8374 the matrix type automatically adapts to the decoded standard (NTSC,PAL) .

Linear amplifiers are used to interface external RGBrn signals (pins 24,25,26) from the SCART connector.

These signals overrule the internal RGB signals when the data insertion pin 26 (FBI) is switched to a level between 1.0V and 3.0V.

The contrast and brightness control and the peak white limiter operate on both internal and external RGB signals R,G and B each have their own, independent gain control to compensate for the difference in phosphor efficiencies of the picture tube: so called "white point" adjustment.

The nominal amplitude is about 2V black to white, at nominal input signals and control settings.

TDA8374 has a black current stabilization loop, that automatically adjust the black level to the cut-off voltage of the picture tubes three gun cathodes.

Since no current is flowing when the voltage the cathode is equal to the cut-off voltage of the tube, the loop stabilizes at a very small gun current.

This "black current" of the three guns is measured internally and compared with a reference current, to adjust the black level of RGBout.

The black level loop is active during 4 lines at the end of the vertical blanking.

In the first line the leakage current is measured (max. acceptable 1100 μ A).

In the next three lines the black levels of the three guns are adjusted.

The nominal value of the 'black current is 10 μ A.

The ratio of the 'black currents' for the 3 guns tracks automatically with the white point adjustment, so the back-ground colour is the same as the adjusted white point.

At switch-on of the TV receiver the black current stabilization circuit is not yet active and RGBout are blanked.

Before the first measurement pulses appear, 0.5 sec delay ensures that the vertical deflection is active, so the pulses will not be visible on the screen.

During the measuring lines RGBout will supply 4V pulses to the video output stages.

The TDA8374 waits until the black current feedback input (pin 18) exceeds 200 μ A, which indicates that the picture tube is warm-up.

Then the black current stabilization circuit is active.

After a waiting time of about 1.0 sec, the blanking of RGBout is released.

Tuning

The AFC information of the TDA8374 is not available as an analogue voltage.

Automatic following (=frequency tracking, AFC) can be done via the I2C-bus by software.

The TDA8374 AFC window is typically 80 kHz wide.

This value is made higher than the 62.5 kHz tuning step, to prevent an automatic following loop from continuously adapting the tuning frequency..

With this AFC window (± 40 kHz) the maximum tuning error is less than 62.5 kHz.

For high speed search-tuning-algorithms, the AFC window can be widened to 240 kHz via bit AFW.

TDA8395 SECAM decoder

The TDA8395 is an alignment-free SECAM colour decoder, including a Cloche filter, demodulator and line identification circuit.

The Cloche filter is a gyrator-capacitor type.

Its frequency is calibrated in the vertical retrace period.

The calibration reference(pin 1) is obtained from the TDA8374 color X-tal oscillator (pin 33).

Pin 7 is a decoupling for the Cloche reference.

The voltage change at this pin due to leakage currents should be lower than 10 mV, during field scan, resulting in a capacitor of minimal 100 nF.

Pin 8 is the reference capacitor for the PLL.

The voltage variation during field scan at this pin should be lower than 2 mV , resulting in a capacitor of 220 nF.

The sandcastle input (pin 15) is connected to TDA8374 pin 41 and is used for generation of the blanking periods and provides clock information for the identification circuit.

The CVBS source select output (TDA8374 pin 38) supplies SECAM chroma to pin 16 of the TDA8395.

This is demodulated by a PLL demodulator, that uses the reference frequency at pin 1 and a bandgap reference to obtain the desired demodulation characteristic.

If the digital line identification in the TDA8395 detects SECAM, pin 1 will sink a current of 150 μ A out of TDA8374 SECAMref pin 33.

When the TDA8374 has not detected PAL or NTSC, it will respond by increasing the voltage at pin 33 from 1.5V to 5V. Now the TDA8374 color difference outputs pin 30 and 29 are made high-ohmic and the TDA8395 output pin 9 and 10 are switched on.

These outputs will be disconnected and high-ohmic when no SECAM is detected for two frame periods, the decoder will be initialized before trying again.

Base band delay line TDA4665

TDA4665 is an integrated double baseband delay line of 64 μ S.

It couples to the TDA8374 and TDA8395 without any switches or alignments.

The TDA4665 consist of two main blocks:

- Two delay lines of 64 sec in switched capacitor technique
- Internal clock generation of 3 MHz, line locked to the sandcastle pulse

The TDA4665 operates according to the mode demanded by the colour transmission standard:

- For PAL it operates as geometric adder to satisfy the PAL demodulation requirements
- In NTSC mode it reduces cross-colour interference (comb-filtering)
- For SECAM it repeats the colour difference signal on consecutive horizontal scan lines.

A sandcastle pulse is connected to pin 5.

The top pulse voltage (should not exceed 5 V) can be directly coupled to the 5 V sandcastle output of the TDA8374.

The R-Y and B-Y colour difference signals (from TDA8374 pins 30 and 29) are AC-coupled and clamped by the input stages at pins 16 and 14.

An internal 6 MHz Current controlled oscillator is line locked via a PLL to the sandcastle pulse at pin 5.

This clock drives the delay lines to obtain the required 64 μ sec.

Sample and hold low pass filters suppress the clock signal.

The original and the delayed signals are added, buffered and fed to the output pins 11 and 12.

These are AC-coupled to the R-Y and B-Y colour difference input pin 32 and 31 of TDA8374.

The TDA4665 needs a 5 V supply voltage on pin 1 for the digital part and on pin 9 for the analog part.

TDA8356 vertical deflection.

The TDA8356 is a vertical deflection circuit.

It can be used in 90 deflection systems with frame frequencies from 50 up to 120 Hz

With its bridge configuration the deflection output can be DC coupled with few external components.

Only a supply voltage for the scan and a second supply for the flyback are needed.

The TDA8356 can drive max.2A.

The vertical drive currents of TDA8374 pins 47 and 46 are connected to input pins 1 and 2 of the TDA8356.

The currents are converted into a voltage by a resistor between pins 1 and 2.

Pin2 is on a fixed DC level (internal bias voltage) and on pin 1 the drive voltage can be measured (typical 1.8 Vpp).

The drive voltage is amplified by 'A' and fed to two amplifiers 'B' and 'C', one is inverting and the other is a non inverting amplifier.

The outputs (pins 4 and 7) are connected to the series connection of the vertical deflection coil and feedback resistor .

The voltage across feedback resistor is fed via pin 9 to correction amplifier 'D', to obtain a deflection current which is proportional to the drive voltage.

The supply voltage for the TDA8356 is 16V at pin 3.

The flyback generator has a separate supply voltage of 45V on pin 6.

The guard pulse is useful to synchronize OSD.

Horizontal deflection

The circuit contains horizontal drive, line output transformer.

The horizontal driver pulses from the TDA8374 are amplified in the horizontal drive circuit, to get sufficient base-drive current for the high voltage switching transistor Q401.

During the horizontal scan period($\approx 52 \mu\text{s}$) Q401 will conduct, and a sawtooth current flows from +110/123V through the primary winding of the FBT to ground.

After this time Q401 is switched off and the energy stored in the FBT during the scan period will be transformed to the flyback capacitor C410.

This energy transfer will take place in a cosine shape because the primary of the FBT and C410 form a resonant circuit. The time the energy is transferred from FBT to C410 and back to the FBT, is called the flyback time and will take place in about $12 \mu\text{s}$.

The flyback peak voltage is about 8 times the scan voltage.

In series with the horizontal deflection coil there is a (damped) linearity corrector coil.

During the scan there is some loss in the resistance of the deflection coil.

In the first part of a line the linearity corrector stores some energy in a permanent magnet until it is saturated.

This improves the linearity of the horizontal scan speed.

The required S correction for the picture tube can be adjusted with the value of C411.

The beam current limiting information (BeamCurr) is derived from the foot of the H.V winding of the FBT.

This is connected via resistor to +8V.

As the beam current increases, the voltage on line BeamCurr decreases.

BeamCurr is damped by an integration filter before it is fed back to TDA8374 pin 22.

The TDA8374 will decrease the contrast (and eventually the brightness) to limit the average beam current.

Video amplifiers

Three TDA6106Q integrated video amplifiers drive cathode of the picture tube directly. They are protected against CRT flashover discharges and ESD (electro static discharge).

The three video amplifiers, have a beam current output I black, used by the TDA8374 black current loop to control the black level on the cathodes.

The outputs can be connected together because the black current loop sequentially controls the black level for each cathode.

The amplification of the TDA6106Q is set by the resistors between pin 3 and 9 and between pin 3 (negative-input) and the TDA8374 output.

There are no alignment any more on the CPT panel, because of the automatic black current stabilization and because the white point adjustment can be done in the TDA8374 via I2C bus.

Power Supply STR-S5707

(1) VIN terminal, start-up circuit

A start-up circuit is to start and stop a operation of a control IC by detecting a voltage appearing at a VIN terminal (pin-9).

At start up of a power supply, when a voltage at the VIN terminal reaches to 8V (typical) by charging up C807 by the function of a start-up resistor, R803, a control circuit starts operating by the function of the start-up circuit.

After the control circuit starts its operation, power source is obtained by smoothing voltage appearing at winding of pin6-7 of T801.

(2) Oscillator, F/B terminal voltage (Pin 7)

A oscillator generates pulse signals which turns a power transistor on and off by making use of charge and discharge of C1 and C2 incorporated in the Hybrid IC.

Constant voltage control of a switch-mode power supply is performed by changing both ON-time and OFF-time except when the load is light (ex. remote control stand-by mode of TVs).

The ON-time is controlled by changing a current charged by C1, which is as the result of that the detection winding of pin5-7 of T801, which detects a change of voltage in a secondary side, connected to the sensing terminal (Pin 7) has the current in accordance with an output signal from an output voltage detection circuit (an error amplifier) built in.

As an AC input voltage to the power supply gets the higher and a load current the smaller, the current flowing to the SENS terminal gets the larger, and the ON-time gets the shorter.

(3) Function of INH terminal (Pin 6), control of OFF-time

Signal to the INH terminal is used as inputs to COMP.1 and COMP.2 inside of the control IC.

A threshold voltage of COMP.1, VTH1 is set at 0.75V ($T_a=25^\circ$) and an input signal to a drive circuit becomes almost 0V (the power transistor is in OFF mode) when a voltage at the INH terminal reaches the VTH1.

A threshold voltage of COMP.2, VTH2, is set at 1.5V ($T_a=25^\circ$).

When the INH terminal voltage reaches VTH2, an output from COMP.2 reverses (the power transistor is in on mode).

* Quasi-resonant operation

By inputting the voltage of winding of pin6-7 of T801 which is synchronized with the energy discharge time of a secondary winding, pin14(or 15)-16 of T801, to the INH terminal through D805 and R809, quasi-resonant operation can be achieved.

When the power transistor turns off and a voltage higher than VTH2 is applied to the INH terminal, C3 immediately discharges and then starts charging again.

Even after the discharge of energy of a secondary winding is completed, VINH does not immediately increases.

When it gets lower than VTH1, the transistor turns on.

* Stand-By Mode

While being in remote control stand-by mode, the output voltage is kept on providing to the secondary side and the power transistor operates at A class mode.

By connecting INH terminal (Pin 6) to the GND, the OFF-time of the power transistor is fixed at set time ($T_{OFF} = 50\mu\text{sec}$ at $T_a = 25^\circ\text{C}$) of the built-in oscillator, and only ON-time changes depending on input and output conditions of the power supply.

Therefore, it enables to hold an oscillation frequency in light mode below 20KHz (typical).

(4) Drive circuit

The STR-S5707 applies the proportional drive system in order to minimize turn-on and saturation loss, and storage time.

(5) OCP (over-current protection) function

Over-current protection is performed pulse by pulse by directly detecting collector current of the power transistor.

Detecting voltage is set to -1V below a reference point of GND (ground).

(6) Latch circuit

It is a circuit which sustains an output from the oscillator low and stops operation of the power supply when over-voltage protection (OVP) circuit and thermal shutdown (TSD) circuit are in operation.

As the sustaining current of the latch circuit is 500 μA maximum when V_{IN} terminal voltage is 4V, the power supply circuit sustains the off state as long as current of 500 μA minimum flows to V_{IN} terminal from a start-up resistor.

In order to prevent a malfunction to be caused by a noise and so on, delay time is provided by C1 incorporated in the IC and, therefore, the latch circuit operates when the OVP or TSD circuit is in operation, or an external signal input is provided for about 10 μsec or longer.

In addition, even after the latch circuit start operating, the constant voltage regulator (Reg) circuit is in operation and the circuit current is at high level.

As a result, V_{IN} terminal voltage rapidly decreases.

When V_{IN} terminal voltage becomes lower than the shutdown voltage, $V_{IN(OFF)}$ (4.9V typical), it starts increasing as the circuit current is below 500 μA .

When it reaches the ON-state voltage, $V_{IN(ON)}$ (8V typical), V_{IN} terminal voltage starts decreasing because the circuit current increases again.

When the latch circuit is on, V_{IN} terminal voltage increases and decreases within the range from 4.9V typical to 8V typical and is prevented from abnormally rising.

Cancellation of the latch is done by decreasing V_{IN} terminal voltage below 3.3V.

The power supply can be restarted after disconnecting an AC input to the power supply once.

(7) Thermal shutdown circuit

It is a circuit to trigger the latch circuit when the frame temperature of the IC exceeds 150 $^\circ\text{C}$ (typical).

Although the temperature is actually sensed at the control chip, it works against overheating of the power transistor as the power transistor and the control IC are mounted on the same lead frame.

(8) Over-voltage protection circuit

It is a circuit to trigger the latch circuit when V_{IN} terminal voltage exceeds 11V (typical).

Although it basically functions as protection of V_{IN} terminal against over-voltage, since V_{IN} terminal is usually supplied from the drive winding of the transformer and the voltage is proportional to the output voltage, it also functions against the over-voltage of secondary output which causes when the control circuit opens or in some other events.

2. NO PICTURE(RASTER OK)

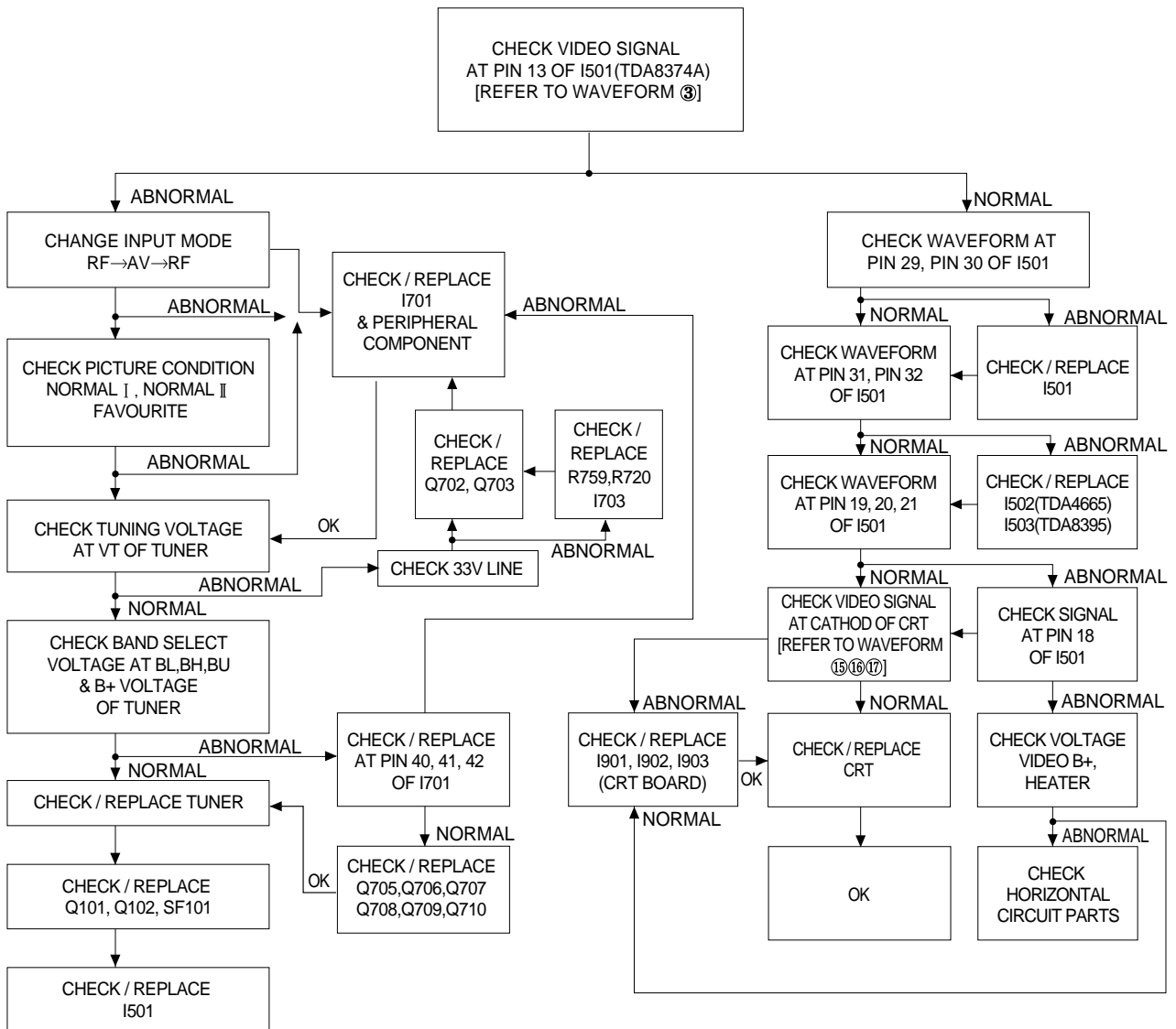

3. NO VERTICAL SCANNING(ONE HORIZONTAL LINE ON SCREEN)

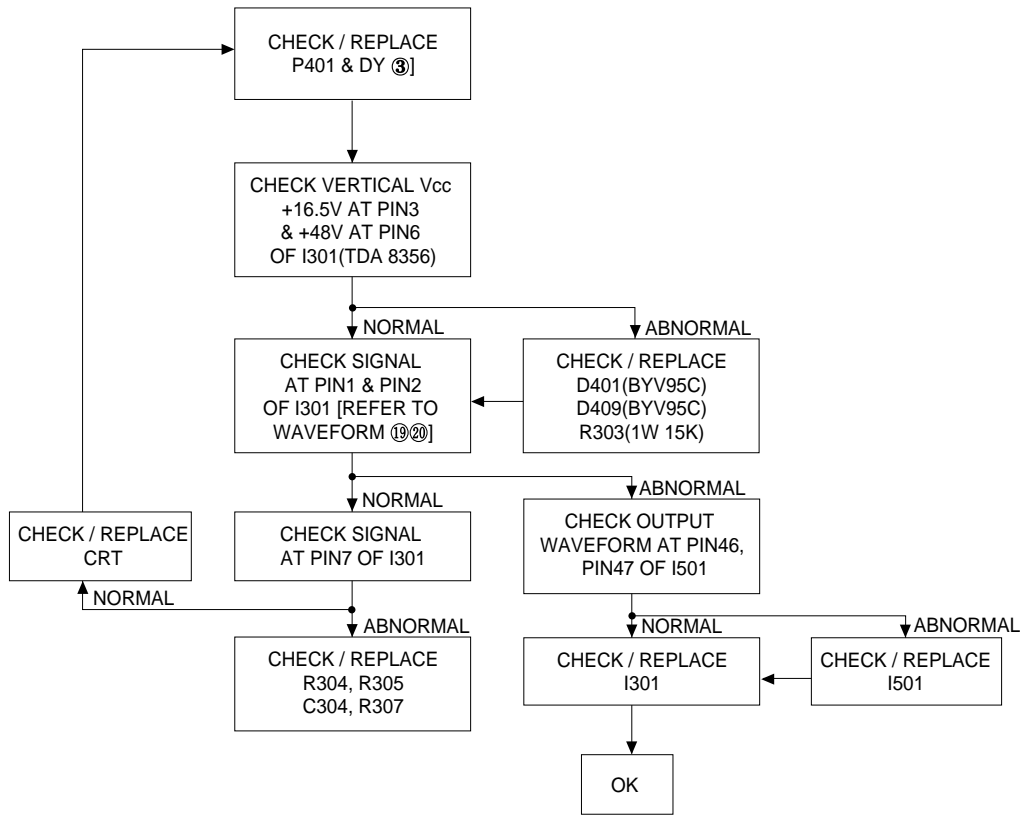

4. NO COLOR

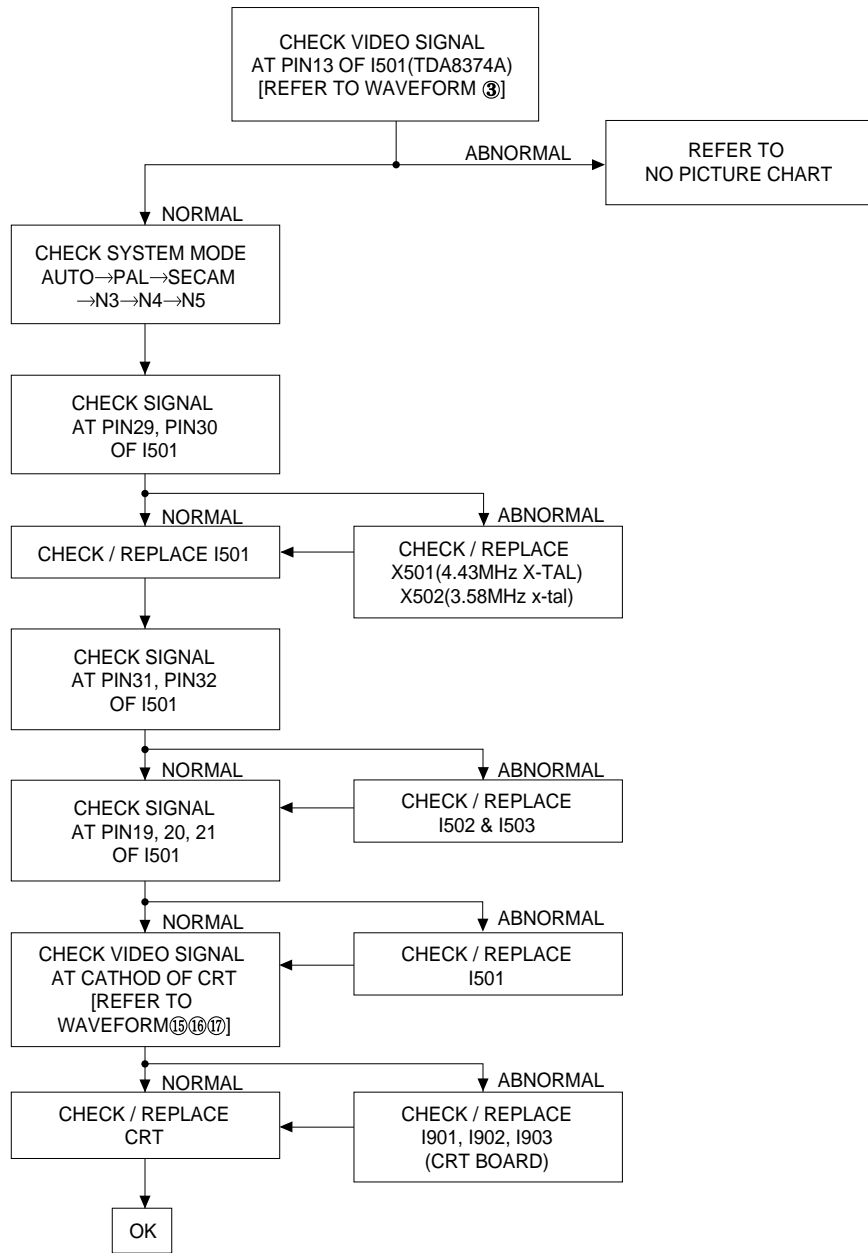

5. NO SOUND(PICTURE OK)

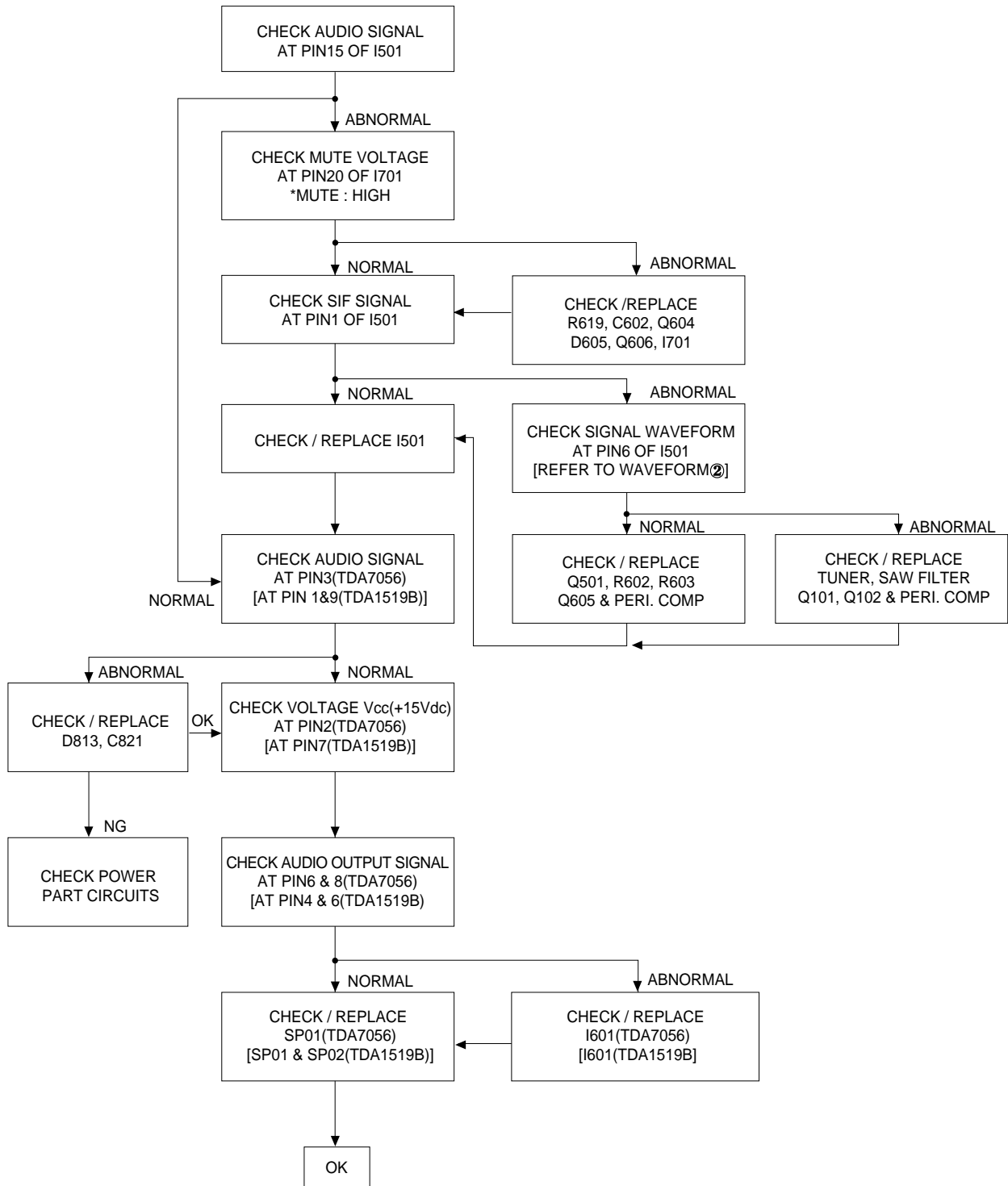

6. NO EXTERNAL A/V(RF OK)

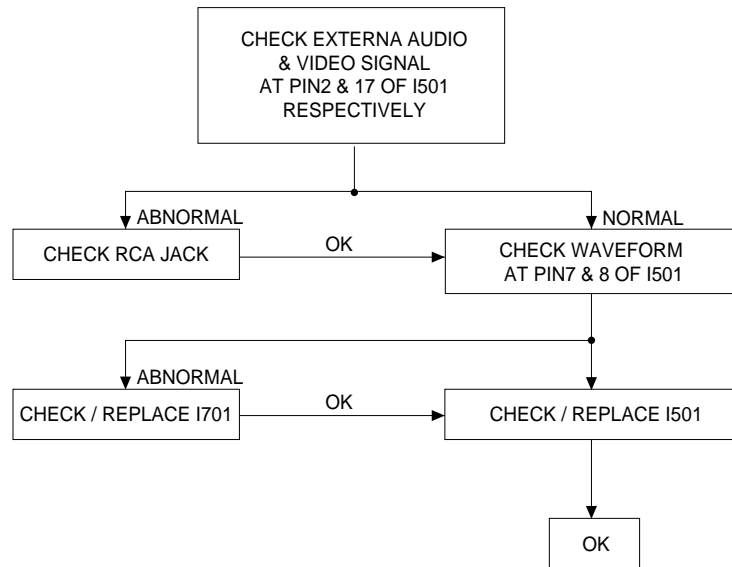

7. NO ON-SCREEN DISPLAY(PICTURE OK)

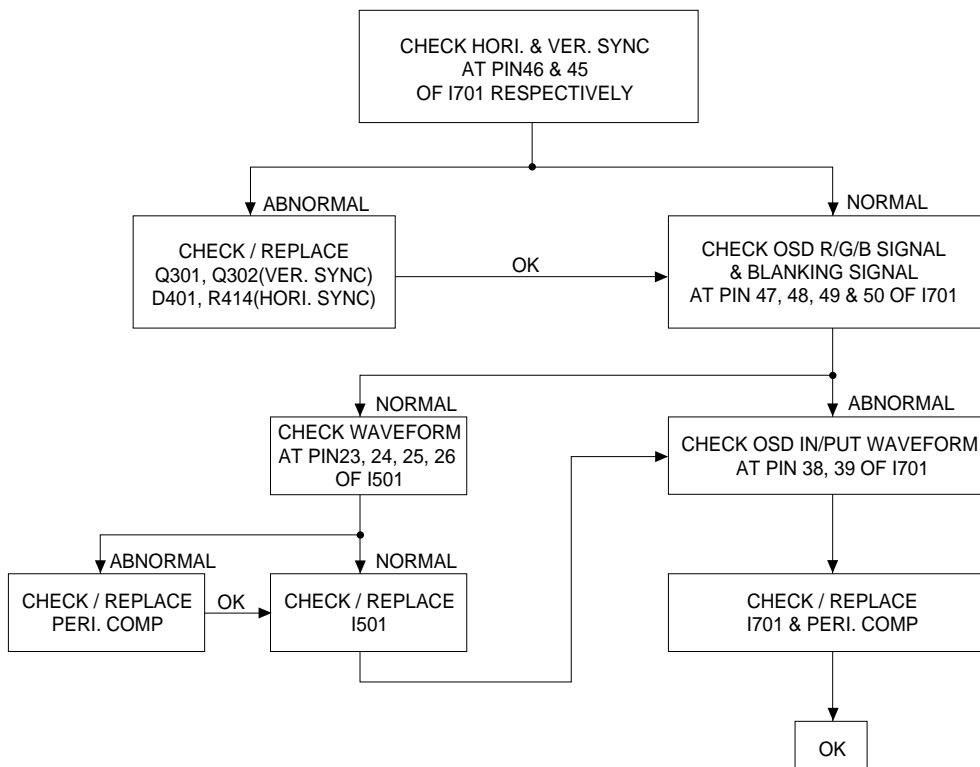

8. REMOTE CONTROL UNIT TROUBLE(LOCAL CONTROL OK)

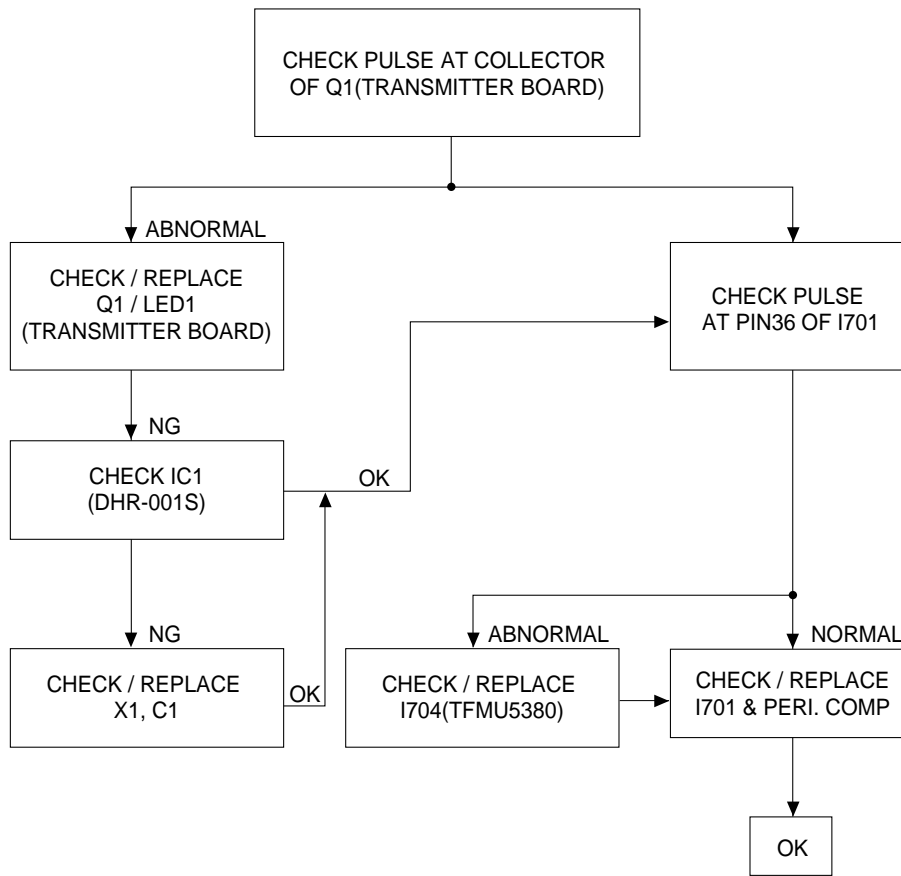

■ IC DC Voltage Charts

- **Input signal**

- Video : color BAR(PM5518)-PAL
- Audio : 1khz sine wave

- **User's control condition**

- Contrast, Brightness, Color, Volume(Normal condition)

- **Line Voltage**

- AC 220V, 50HZ

- **All the Voltage in each point are measured with multimeter**

- **I701(μ-com)**

PIN NO	1	2	3	4	5	6	7	8	9	10	11	12	13	14	15
V(DC)	0	4.7	4.5	4.5	4.7	0	0	0	0	0	4.4	2.0	2.2	0	4.7

(option)

PIN NO	16	17	18	19	20	21	22	23	24	25	26	27	28	29	30
V(DC)	4.0	0	4.4	0	0	0	0	0	0	0	0	0	0	0	0

MUTE\4.2 (TEXT option) →

PIN NO	31	32	33	34	35	36	37	38	39	40	41	42	43	44	45
V(DC)	0 →	4.6	4.7	0	0	4.6	4.6	3.7	3.7	4.4	0	0	4.4	0	2.9

PIN NO	46	47	48	49	50	51	52
V(DC)	0.2	0	0	0	0	0	0

• I501(TDA8374A)

PIN NO	1	2	3	4	5	6	7	8	9	10	11	12	13	14
V(DC)	0	3.8	3.6	3.6	2.8	3.0	4.6	4.6	6.64	0	3.4	8.0	100mv	G

PIN NO	15	16	17	18	19	20	21	22	23	24	25	26	27	28
V(DC)	3.76	3.7	3.5	5.3	2.5	3.8	2.7	3.1	3.4	3.4	3.4	0	2.5	2.5

PIN NO	29	30	31	32	33	34	35	36	37	38	39	40	41	42
V(DC)	1.7	1.7	4.0	4.0	1.6	2.6	2.6	4.6	8.0	3.4	6.0	3.0	0	4.8

PIN NO	43	44	45	46	47	48	49	50	51	52	53	54	55	56
V(DC)	4.0	G	8.0	2.3	2.3	4.2	4.2	0	3.9	4.0	3.7	3.4	3.2	4.7

• I301(TDA8356)

PIN NO	1	2	3	4	5	6	7	8	9						
V(DC)	2.3	2.3	16.8	8.0	0	44	8.1	0	8.1						

• I502(TDA4665)

PIN NO	1	2	3	4	5	6	7	8	9	10	11	12	13	14	15	16
V(DC)	5.0	0	0	0	0	0	1.0	0	5.0	0	2.9	2.9	0	1.4	0.7	114

• I503(TDA8395)

PIN NO	1	2	3	4	5	6	7	8	9	10	11	12	13	14	15	16
V(DC)	1.6	1.2	7.9	0	0	0	3.3	4.2	1.7	1.7	0	0	0	0	0.7	2.8

• I802(TDA8138)

PIN NO	1	2	3	4	5	6	7	8	9							
V(DC)	13.0	14.0	3.0	4.82	G	5.05	0	11.98	5.05							

■ Electrical Parts List

LOC.	PART-CODE	PART-NAME	PART TYPE	REMARK
ZZ100	48B3228B04	TRANSMITTER REMOCON	R-28B04	
ZZ110	PTACPWA499	ACCESSORY AS	DTC-14Q1VM	
M821	4858211400	POLY BAG	P.E FILM T0.03X600X550	
30	47P7500001	BATTERY	AAM 1.5V	
10000	48586A1617	MANUAL INSTRUCTION	ALL	
ZZ120	PTBCSHA499	COVER BACK AS	DTC-14Q1VM	
M211	4852147200	COVER BACK	HIPS BK	
M541	4855415800	SPEC PLATE	150ART P/E FILM (C/TV)	
M781	4857817611	CLOTH BLACK	FELT T0.7 L=200	
ZZ130	PTPKCPA499	PACKING AS	DTC-14Q1VM	
10	6520010100	STAPLE PIN	18M/M J D O	
20	6520010200	STAPLE PIN	#3417	
M801	485803871D	BOX CARTON	SW-2	
M811	4858179200	PAD	EPS 14Q1	
M821	4858210702	BAG P.E	L.D.P.E T0.03X1150X1000	
M822	4858211400	POLY BAG	P.E FILM T0.03X600X550	
40	2TF01612CL	TAPE FILAMENT	12MMX55ME CLEAR	
ZZ131	58G0000084	COIL DEGAUSSING	DC-1450	
ZZ132	48519A4610	CRT GROUND AS	1401H-1015-1P	
ZZ140	PTCACAA499	CABINET AS	DTC-14Q1VM	
M191	4851924401	BUTTON CTRL AS	4933001+5530400	
M201A	4856013300	SCREW CRT FIXING AS	30X80 BK	
M201B	4856214900	WASHER RUBBER	TMR-CA	
M201C	4856013301	SCREW CRT FIXING AS	30X140 YL	
M211A	7122401412	SCREW TAPPING	T2S TRS 4X14 MFZN BK	
M211C	7128301212	SCREW TAPPING	T2S WAS 3X12 MFZN BK	
M211D	7122401412	SCREW TAPPING	T2S TRS 4X14 MFZN BK	
M481	4854848200	BUTTON POWER	ABS BK	
M481A	4856716000	SPRING	SWPA PIE0.5	
M561	4855613600	MARK BRAND	COPPER T0.4	
SP01A	7128301011	SCREW TAPPING	T2S WAS 3X10 MFZN	
V901	PTRTPWA001	CRT AS	PAL 14' ITC CRT AS	
V01	58D1000046	COIL DY	ODY-M1401	
V02	48A96R004-	RUBBER WEDGE	HMR 28 SR (10X54)	
V03	4850PM001-	MAGNET CP	NY-225 (MINI NECK)	
V04	2TG00025—	TAPE GLASS	W25	
V05	2224050033	BOND SILICON	RTV 252	
V901	48A96414P1	CRT BARE	A34JLL90X	
J	48A96414P2	CRT BARE	A34JLL91X	
J	48A96414P3	CRT BARE	A34JLL92X	
ZZ200	PTFMSJA499	MASK FRONT AS	DTC-14Q1VM	
M201	4852060500	MASK FRONT	HIPS BK	
M351	4853533201	HOLDER BRKT	HIPS BK	

LOC.	PART-CODE	PART-NAME	PART TYPE	REMARK
ZZ220	PTSPWA499	SPEAKER AS	DTC-14Q1VM	
PA601	4850703S03	CONN AS	YH025-03+YST025+ULW=200	
SP01	4858306810	SPEAKER	3W 16 OHM F2035C03-3	
ZZ290	PTMPMSA499	PCB MAIN MANUAL AS	DTC-14Q1VM	
10	2193102005	SOLDER BAR	SN:PB=63:47 S63S-1320	
20	2193011101	SOLDER WIRE	RS 60-1.2 1.6A	
30	2291050615	FLUX SOLDER	DF-2012U	
40	2291050301	FLUX SOLVENT	IM-1000	
50	2291140501	WAX COVER		
C410	CMYH3C692J	C MYLAR	1.6KV BUP 6900PF J	
C411	CMYE2D334J	C MYLAR	200V PU 0.33MF J	
C416	CCYR3A102K	C CERA	HIKR 1KV 1000PF K 125C	
C801	CL1UC3104M	C LINE ACROSS	WORLD AC250V 0.1UF M R.47	
C806	CEYA2G221G	C ELECTRO	400V LSS 220MF (30X40)	
C814	CCYR3D102K	C CERA	2KV R 1000PF K 125C	
C832	CH1BFE472M	C CERA AC	AC400V 4700PF M U/C/V	
C911	CCYB3D472K	C CERA	2KV B 4700PF K	
D103	D1S2186—	DIODE	1S2186	
D601	D1S2186—	DIODE	1S2186	
D706	DKLR114L—	LED	KLR114L	
D812	DBYW95C—	DIODE	BYW95C (TAPPING)	
F801	5FSGB4022L	FUSE GLASS TUBE	SEMKO TL 4A 250V MF51	
I301	1TDA8356—	IC VERTICAL	TDA8356	
I301A	4857024617	HEAT SINK	AL EX	
I301B	7174301011	SCREW TAPPTITE	TT2 RND 3X10 MFZN	
I501	1TDA8374A-	IC VCD	TDA8374A	
I502	1TDA4665V4	IC DELAY	TDA4665/V4	
I503	1TDA8395—	IC	TDA8395	
I601	1TDA7056—	IC	TDA7056	
I601A	4857025400	HEAT SINK	A1050P-H24 T2.0	
I601B	7174300811	SCREW TAPPTITE	TT2 RND 3X8 MFZN	
I701	1DW370ASM1	IC MICOM	DW370ASM1	
I702	124LC08B—	IC MEMORY	24LC08B	
I703	1UPC574J—	IC	UPC574J	
I704	1TFMW5380-	IC PREAMP	TFMW5380	
I801	1STRS5707-	IC POWER	STR-S5707	
I801A	4857026107	HEAT SINK	AL EX	
I801B	7174301011	SCREW TAPPTITE	TT2 RND 3X10 MFZN	
I802	1TDA8138—	IC REGULATOR	TDA8138	
I802A	4857025401	HEAT SINK	A1050P-H24 T2	
I802B	7174300811	SCREW TAPPTITE	TT2 RND 3X8 MFZN	
I803	1KA7808—	IC REGULATOR	KA7808	
I804	1LTV817C—	IC PHOTO COUPLER	LTV-817C	

LOC.	PART-CODE	PART-NAME	PART TYPE	REMARK
I901	1TDA6106Q-	IC AMP	TDA6106Q	
I902	1TDA6106Q-	IC AMP	TDA6106Q	
I903	1TDA6106Q-	IC AMP	TDA6106Q	
JA01	WP-1BK1715	WIRE LEAD 1007	AWG22 1/0.65 BK 5-170-5	
JA02	WP-1BK1715	WIRE LEAD 1007	AWG22 1/0.65 BK 5-170-5	
JV03	4859104250	JACK PIN BOARD	YSC-0406(YW+YW+RD+RD)	
L102	58C9780027	COIL CHOKE	TRF-1201B (0.97 UH)	
L405	58H0000016	COIL H-LINEARITY	L-102 (102UH)	
L603	58C9430599	COIL CHOKE	AZ-9004Y(94MH)	
L801	5PLF20A1—	FILTER LINE	LF-20A1	
L803	58C9430599	COIL CHOKE	AZ-9004Y(94MH)	
M352	97P2316600	HOLDER AC CORD	NYLON66 UL/CSA	
M353	4853530901	HOLDER LED	HIPS BK	
M681	4856812001	TIE CABLE	NYLON66 DA100	
M791	4857913302	RUBBER CUSHION	FR RUBBER SPONGE	
PA501	4850706S02	CONN AS	YH025-06+YST025+ULW=400	
PA502	4850704S04	CONN AS	YH025-04+YST025+ULW=400	
PWC1	4859902910	CORD POWER AS	KKP419C+BL102NG+TUBE=2100	
A000	4859901111	CORD POWER	KKP-419C KLCE-2F (2.1ME)	
P401	4859240020	CONN WAFER	YFW500-05	
P801	4859242220	CONN WAFER	YFW800-02	
P802	4859242220	CONN WAFER	YFW800-02	
P904	4859275220	CONN WAFER	YF254-05R (ANGLE)	
P905	4859262120	CONN WAFER	YFW800-01	
Q402	T2SD2499—	TR	2SD2499	
Q402A	4857027200	HEAT SINK	AL T1.0	
Q402B	7174301011	SCREW TAPPTITE	TT2 RND 3X10 MFZN	
R801	DEC140M290	POSISTOR	ECPC140M290	
R803	RX10B339JN	R CEMENT	10W 3.3 OHM J BENCH 4P	
SCT1	4859303030	SOCKET CRT	ISMM03S	
SF101	5PK6259K—	FILTER SAW	K6259K	
SW01	5S50101008	SW TACT	KPT-1105V 1C-1P	
SW02	5S50101008	SW TACT	KPT-1105V 1C-1P	
SW03	5S50101008	SW TACT	KPT-1105V 1C-1P	
SW04	5S50101008	SW TACT	KPT-1105V 1C-1P	
SW05	5S50101008	SW TACT	KPT-1105V 1C-1P	
SW801	5S40101143	SW PUSH	PS3-22SP (P.C.B)	
TU01	4859709230	TUNER VARACTOR	VTSS7SZ3	
TU01A	4859101820	JACK ANT	JACK-D1	
T401	50D10A2—	TRANS DRIVE	TD-10A2	
T402	50H0000177	FBT	HST1142.5057	
T801	50M4242A5-	TRANS SMPS	TSM-4242A5	
X701	5XE20R000E	CRYSTAL QUARTZ	HC-49/U 20.000MHZ 30PPM	

LOC.	PART-CODE	PART-NAME	PART TYPE	REMARK
Z503	5PTPS60MB-	FILTER CERA	TPS 6.0MB(EFC-S6ROME3)	
Z504	5PTPS65MB-	FILTER CERA	TPS 6.5MB(EFC-S6R5ME3)	
ZZ200	PTMPJ0A499	PCB MAIN (RHU) AS	DTC-14Q1VM	
C308	CEXF1E471C	C ELECTRO	25V RUS 470MF (10X16) TP	
C412	CEXF2C339V	C ELECTRO	160V RSS 3.3MF (8X16) TP	
C417	CEXF2E330V	C ELECTRO	250V RSS 33MF (13X25) TP	
C427	CCXB3D471K	C CERA	2KV B 470PF K (TAPPING)	
C428	CEXF2C470V	C ELECTRO	160V RSS 47MF (13X25) TP	
C615	CEXF1V331C	C ELECTRO	35V RUS 330MF (10X20) TP	
C809	CEXF1E331V	C ELECTRO	25V RSS 330MF (10X12.5)TP	
C818	CEXF2C101V	C ELECTRO	160V RSS 100MF (16X25) TP	
C819	CEXF2C101V	C ELECTRO	160V RSS 100MF (16X25) TP	
C821	CEXF1V102V	C ELECTRO	35V RSS 1000MF (13X25) TP	
C823	CEXF1E222C	C ELECTRO	25V RUS 2200MF (16X25) TP	
ZZ200	PTMPJBA499	PCB MAIN M-10 AS	DTC-14Q1VM	
L104	58E0000S37	COIL AFT	TRF-A001	
P101	485923162S	CONN WAFER	YW025-03 (STICK)	
P102	485923162S	CONN WAFER	YW025-03 (STICK)	
P501	485923192S	CONN WAFER	YW025-06 (STICK)	
P502	485923172S	CONN WAFER	YW025-04 (STICK)	
P601	485923162S	CONN WAFER	YW025-03 (STICK)	
R303	RS01Z153J-	R M-OXIDE FILM	1W 15K OHM J (TAPPING)	
R307	RS02Z271J-	R M-OXIDE FILM	2W 270 OHM J (TAPPING)	
R408	RS02Z561J-	R M-OXIDE FILM	2W 560 OHM J (TAPPING)	
R409	RS01Z103J-	R M-OXIDE FILM	1W 10K OHM J (TAPPING)	
R415	RF01Z129J-	R FUSIBLE	1W 1.2 OHM J (TAPPING)	
R720	RS02Z562JS	R M-OXIDE FILM	2W 5.6K OHM J SMALL	
R759	RS02Z562JS	R M-OXIDE FILM	2W 5.6K OHM J SMALL	
R805	RS02Z363J-	R M-OXIDE FILM	2W 36K OHM J (TAPPING)	
R811	RS01Z240J-	R M-OXIDE FILM	1W 24 OHM J (TAPPING)	
R812	RF02Z338J-	R FUSIBLE	2W 0.33 OHM J (TAPPING)	
R814	RS02Z563J-	R M-OXIDE FILM	2W 56K OHM J (TAPPING)	
R824	RS02Z430JS	R M-OXIDE FILM	2W 43 OHM J SMALL	
R825	RS02Z330J-	R M-OXIDE FILM	2W 33 OHM J (TAPPING)	
ZZ200	PTMPJRA499	PCB MAIN RADIAL AS	DTC-14Q1VM	
CA04	CEXF1H479V	C ELECTRO	50V RSS 4.7MF (5X11) TP	
CA05	CEXF1H100V	C ELECTRO	50V RSS 10MF (5X11) TP	
C103	CEXF1E470V	C ELECTRO	25V RSS 47MF (5X11) TP	
C104	CEXF1H479V	C ELECTRO	50V RSS 4.7MF (5X11) TP	
C105	CEXF1H479V	C ELECTRO	50V RSS 4.7MF (5X11) TP	
C107	CEXF1H479V	C ELECTRO	50V RSS 4.7MF (5X11) TP	
C109	CEXF1H100V	C ELECTRO	50V RSS 10MF (5X11) TP	
C111	CMXM2A104J	C MYLAR	100V 0.1MF J (TP)	

LOC.	PART-CODE	PART-NAME	PART TYPE	REMARK
C115	CEXF1H229V	C ELECTRO	50V RSS 2.2MF (5X11) TP	
C116	CMXM2A223J	C MYLAR	100V 0.022MF J TP	
C117	CMXM2A473J	C MYLAR	100V 0.047MF J (TP)	
C119	CMXM2A473J	C MYLAR	100V 0.047MF J (TP)	
C301	CMXB1H104J	C MYLAR	50V EU 0.1MF J (TP)	
C304	CMXB1H104J	C MYLAR	50V EU 0.1MF J (TP)	
C305	CMXM2A103J	C MYLAR	100V 0.01MF J (TP)	
C306	CBXF1H104Z	C CERA SEMI	50V F 0.1MF Z (TAPPING)	
C311	CMXM2A104J	C MYLAR	100V 0.1MF J (TP)	
C402	CEXF1H109V	C ELECTRO	50V RSS 1MF (5X11) TP	
C406	CCXB2H222K	C CERA	500V B 2200PF K (TAPPING)	
C413	CEXF1H100V	C ELECTRO	50V RSS 10MF (5X11) TP	
C414	CCXB2H471K	C CERA	500V B 470PF K (TAPPING)	
C415	CMXM2A104J	C MYLAR	100V 0.1MF J (TP)	
C418	CMXM2A223J	C MYLAR	100V 0.022MF J TP	
C419	CEXF1E101V	C ELECTRO	25V RSS 100MF (6.3X11) TP	
C420	CXSL2H470J	C CERA	500V SL 47PF J (TAPPING)	
C423	CCXB2H102K	C CERA	500V B 1000PF K (TAPPING)	
C502	CEXF1H229V	C ELECTRO	50V RSS 2.2MF (5X11) TP	
C503	CMXM2A223J	C MYLAR	100V 0.022MF J TP	
C504	CMXM2A223J	C MYLAR	100V 0.022MF J TP	
C505	CEXF1E101V	C ELECTRO	25V RSS 100MF (6.3X11) TP	
C506	CMXM2A473J	C MYLAR	100V 0.047MF J (TP)	
C508	CMXM2A473J	C MYLAR	100V 0.047MF J (TP)	
C509	CEXF1H478V	C ELECTRO	50V RSS 0.47MF (5X11) TP	
C510	CMXM2A473J	C MYLAR	100V 0.047MF J (TP)	
C512	CEXF1H109V	C ELECTRO	50V RSS 1MF (5X11) TP	
C525	CEXF1E470V	C ELECTRO	25V RSS 47MF (5X11) TP	
C526	CMXM2A104J	C MYLAR	100V 0.1MF J (TP)	
C527	CMXL1J224J	C MYLAR	63V MEU 0.22MF J (TP)	
C529	CEXF1E470V	C ELECTRO	25V RSS 47MF (5X11) TP	
C530	CEXF1H109V	C ELECTRO	50V RSS 1MF (5X11) TP	
C531	CMXM2A104J	C MYLAR	100V 0.1MF J (TP)	
C532	CMXM2A104J	C MYLAR	100V 0.1MF J (TP)	
C533	CMXM2A104J	C MYLAR	100V 0.1MF J (TP)	
C534	CEXF1E101V	C ELECTRO	25V RSS 100MF (6.3X11) TP	
C602	CEXF1E330V	C ELECTRO	25V RSS 33MF (5X11) TP	
C607	CEXD1E100F	C ELECTRO	25V RND 10MF (5X11) TP	
C610	CEXF1H229V	C ELECTRO	50V RSS 2.2MF (5X11) TP	
C611	CEXF1H100V	C ELECTRO	50V RSS 10MF (5X11) TP	
C614	CMXM2A223J	C MYLAR	100V 0.022MF J TP	
C617	CEXF1E221V	C ELECTRO	25V RSS 220MF (8X11.5) TP	
C622	CEXF1H100V	C ELECTRO	50V RSS 10MF (5X11) TP	

LOC.	PART-CODE	PART-NAME	PART TYPE	REMARK
C702	CEXF1E470V	C ELECTRO	25V RSS 47MF (5X11) TP	
C706	CEXF1H100V	C ELECTRO	50V RSS 10MF (5X11) TP	
C707	CEXF1E101V	C ELECTRO	25V RSS 100MF (6.3X11) TP	
C710	CMXM2A104J	C MYLAR	100V 0.1MF J (TP)	
C711	CMXM2A104J	C MYLAR	100V 0.1MF J (TP)	
C712	CEXF1H470V	C ELECTRO	50V RSS 47MF (6.3X11) TP	
C713	CCXF1H103Z	C CERA	50V F 0.01MF Z (TAPPING)	
C721	CEXF1E470V	C ELECTRO	25V RSS 47MF (5X11) TP	
C725	CEXF1E470V	C ELECTRO	25V RSS 47MF (5X11) TP	
C802	CCXF3A472Z	C CERA	1KV F 4700PF Z (T)	
C803	CCXF3A472Z	C CERA	1KV F 4700PF Z (T)	
C804	CCXF3A472Z	C CERA	1KV F 4700PF Z (T)	
C805	CCXF3A472Z	C CERA	1KV F 4700PF Z (T)	
C808	CEXF2A479V	C ELECTRO	100V RSS 4.7MF (5X11) TP	
C810	CEXF1E221V	C ELECTRO	25V RSS 220MF (8X11.5) TP	
C812	CCXB3A102K	C CERA	1KV B 1000PF K (TAPPING)	
C817	CCXB3A102K	C CERA	1KV B 1000PF K (TAPPING)	
C820	CCXB2H471K	C CERA	500V B 470PF K (TAPPING)	
C822	CCXB2H471K	C CERA	500V B 470PF K (TAPPING)	
C824	CEXF1E101V	C ELECTRO	25V RSS 100MF (6.3X11) TP	
C826	CEXF1E470V	C ELECTRO	25V RSS 47MF (5X11) TP	
C830	CEXF1E101V	C ELECTRO	25V RSS 100MF (6.3X11) TP	
C904	CMXL2E104K	C MYLAR	250V MEU 0.1MF K	
C905	CMXL2E104K	C MYLAR	250V MEU 0.1MF K	
C906	CMXL2E104K	C MYLAR	250V MEU 0.1MF K	
C907	CCXB1H561K	C CERA	50V B 560PF K (TAPPING)	
C908	CCXB1H561K	C CERA	50V B 560PF K (TAPPING)	
C909	CCXB1H561K	C CERA	50V B 560PF K (TAPPING)	
F801A	4857415001	CLIP FUSE	PFC5000-0702	
F801B	4857415001	CLIP FUSE	PFC5000-0702	
QA02	TKTC3198Y-	TR	KTC3198Y	
Q101	TKTC3197—	TR	KTC3197 (TP)	
Q102	TKTC3198Y-	TR	KTC3198Y	
Q301	TKTC3198Y-	TR	KTC3198Y	
Q302	TKTC3198Y-	TR	KTC3198Y	
Q303	TKTC3198Y-	TR	KTC3198Y	
Q401	T2SD1207T-	TR	2SD1207-T (TAPPING)	
Q501	TKTC3198Y-	TR	KTC3198Y	
Q502	TKTC3198Y-	TR	KTC3198Y	
Q503	TKTC3198Y-	TR	KTC3198Y	
Q504	TKTA1266Y-	TR	KTA1266Y (TP)	
Q505	TKTC3198Y-	TR	KTC3198Y	
Q506	TKTC3198Y-	TR	KTC3198Y	

LOC.	PART-CODE	PART-NAME	PART TYPE	REMARK
Q507	TKTA1266Y-	TR	KTA1266Y (TP)	
Q601	TKTC3198Y-	TR	KTC3198Y	
Q602	TKTC3198Y-	TR	KTC3198Y	
Q603	TKTC3198Y-	TR	KTC3198Y	
Q604	TKTC3198Y-	TR	KTC3198Y	
Q605	TKTC3198Y-	TR	KTC3198Y	
Q606	TKTA1266Y-	TR	KTA1266Y (TP)	
Q702	TKTC3202Y-	TR	KTC3202Y (TP)	
Q703	TKTC3198Y-	TR	KTC3198Y	
Q705	TKTC3198Y-	TR	KTC3198Y	
Q706	TKTC3198Y-	TR	KTC3198Y	
Q707	TKTC3198Y-	TR	KTC3198Y	
Q708	TKTA1266Y-	TR	KTA1266Y (TP)	
Q709	TKTA1266Y-	TR	KTA1266Y (TP)	
Q710	TKTA1266Y-	TR	KTA1266Y (TP)	
Q711	TKTC3198Y-	TR	KTC3198Y	
Q713	TKTC3198Y-	TR	KTC3198Y	
Q715	TKTC3198Y-	TR	KTC3198Y	
Q802	TKTC3198Y-	TR	KTC3198Y	
Q803	TKTC3198Y-	TR	KTC3198Y	
X501	5XEX4R436C	CRYSTAL QUARTZ	HC-49U 4.433619M 20PP TA	
X502	5XEX3R579C	CRYSTAL QUARTZ	HC-49U 3.579545M (TP)	
Z501	5PXPS45MB-	FILTER CERA	TPS-4.5MB TRAP (TAPPING)	
Z502	5PXPS5R5MB	FILTER CERA	TPS5.5MB-TF21 (TP)	
Z601	5PXFSH5R5M	FILTER CERA	SFSH5.5MCB-TF21 (TP)	
Z602	5PXFSH6R5M	FILTER CERA	SFSH6.5MCB-TF21 (TP)	
Z603	5PXFSH4R5M	FILTER CERA	SFSH4.5MCB-TF21 (TP)	
Z604	5PXFSH6R0M	FILTER CERA	SFSH6.0MCB-TF21 (TP)	
ZZ200	PTMPJAA499	PCB MAIN AXIAL AS	DTC-14Q1VM	
A001	4859811892	PCB MAIN	330X246 S1B	
CA02	CCZB1H561K	C CERA	50V B 560PF K (AXIAL)	
CA03	CBZF1H104Z	C CERA SEMI	50V F 0.1MF Z (AXIAL)	
C101	CCZB1H102K	C CERA	50V B 1000PF K (AXIAL)	
C102	CCZF1E103Z	C CERA	25V F 0.01MF Z (AXIAL)	
C106	CCZF1E103Z	C CERA	25V F 0.01MF Z (AXIAL)	
C108	CCZF1E103Z	C CERA	25V F 0.01MF Z (AXIAL)	
C110	CCZF1E103Z	C CERA	25V F 0.01MF Z (AXIAL)	
C112	CCZF1E103Z	C CERA	25V F 0.01MF Z (AXIAL)	
C113	CCZF1E103Z	C CERA	25V F 0.01MF Z (AXIAL)	
C114	CCZB1H331K	C CERA	50V B 330PF K (AXIAL)	
C118	CZCH1H100J	C CERA	50V CH 10PF J (AXIAL)	
C120	CCZB1H102K	C CERA	50V B 1000PF K (AXIAL)	
C121	CCZF1E103Z	C CERA	25V F 0.01MF Z (AXIAL)	

LOC.	PART-CODE	PART-NAME	PART TYPE	REMARK
C122	CBZF1H104Z	C CERA SEMI	50V F 0.1MF Z (AXIAL)	
C302	CCZB1H181K	C CERA	50V B 180PF K (AXIAL)	
C303	CCZB1H181K	C CERA	50V B 180PF K (AXIAL)	
C401	CBZR1C472M	C CERA	16V Y5R 4700PF M (AXIAL)	
C403	CBZR1C222M	C CERA	16V Y5R 2200PF M (AXIAL)	
C404	CBZR1C222M	C CERA	16V Y5R 2200PF M (AXIAL)	
C405	CCZF1E103Z	C CERA	25V F 0.01MF Z (AXIAL)	
C501	CBZF1H104Z	C CERA SEMI	50V F 0.1MF Z (AXIAL)	
C511	CCZB1H181K	C CERA	50V B 180PF K (AXIAL)	
C513	CBZF1H104Z	C CERA SEMI	50V F 0.1MF Z (AXIAL)	
C515	CZCH1H180J	C CERA	50V CH 18PF J (AXIAL)	
C516	CBZF1H104Z	C CERA SEMI	50V F 0.1MF Z (AXIAL)	
C517	CBZR1C472M	C CERA	16V Y5R 4700PF M (AXIAL)	
C518	CZCH1H180J	C CERA	50V CH 18PF J (AXIAL)	
C519	CBZF1H104Z	C CERA SEMI	50V F 0.1MF Z (AXIAL)	
C520	CBZF1H104Z	C CERA SEMI	50V F 0.1MF Z (AXIAL)	
C521	CCZB1H102K	C CERA	50V B 1000PF K (AXIAL)	
C522	CCZB1H102K	C CERA	50V B 1000PF K (AXIAL)	
C523	CCZF1E223Z	C CERA	25V F 0.022MF Z (AXIAL)	
C524	CBZF1H104Z	C CERA SEMI	50V F 0.1MF Z (AXIAL)	
C528	CCZF1E103Z	C CERA	25V F 0.01MF Z (AXIAL)	
C601	CCZB1H102K	C CERA	50V B 1000PF K (AXIAL)	
C605	CZSL1H560J	C CERA	50V SL 56PF J (AXIAL)	
C606	CZSL1H680J	C CERA	50V SL 68PF J (AXIAL)	
C613	CCZF1E103Z	C CERA	25V F 0.01MF Z (AXIAL)	
C616	CBZR1C392M	C CERA	16V Y5R 3900PF M (AXIAL)	
C703	CZCH1H150J	C CERA	50V CH 15PF J (AXIAL)	
C704	CZCH1H150J	C CERA	50V CH 15PF J (AXIAL)	
C705	CCZF1E103Z	C CERA	25V F 0.01MF Z (AXIAL)	
C709	CCZB1H102K	C CERA	50V B 1000PF K (AXIAL)	
C720	CCZF1E103Z	C CERA	25V F 0.01MF Z (AXIAL)	
C722	CZSL1H390J	C CERA	50V SL 39PF J (AXIAL)	
C723	CZSL1H390J	C CERA	50V SL 39PF J (AXIAL)	
C724	CCZF1E103Z	C CERA	25V F 0.01MF Z (AXIAL)	
C726	CCZB1H331K	C CERA	50V B 330PF K (AXIAL)	
C727	CCZB1H561K	C CERA	50V B 560PF K (AXIAL)	
C825	CCZF1E103Z	C CERA	25V F 0.01MF Z (AXIAL)	
C827	CCZF1E103Z	C CERA	25V F 0.01MF Z (AXIAL)	
C829	CCZF1E103Z	C CERA	25V F 0.01MF Z (AXIAL)	
C831	CBZF1H104Z	C CERA SEMI	50V F 0.1MF Z (AXIAL)	
DA01	DUZ6R2BM—	DIODE ZENER	UZ-6.2BM 6.2V	
DA02	DUZ9R1BM—	DIODE ZENER	UZ-9.1BM 9.1V	
DA03	DUZ6R2BM—	DIODE ZENER	UZ-6.2BM 6.2V	

LOC.	PART-CODE	PART-NAME	PART TYPE	REMARK
DA04	DUZ9R1BM—	DIODE ZENER	UZ-9.1BM 9.1V	
DA06	DUZ9R1BM—	DIODE ZENER	UZ-9.1BM 9.1V	
DA09	DUZ9R1BM—	DIODE ZENER	UZ-9.1BM 9.1V	
DO401	DUZ5R1BM—	DIODE ZENER	UZ-5.1BM	
D102	D1N4148—	DIODE	1N4148 (TAPPING)	
D301	DUZ5R1BM—	DIODE ZENER	UZ-5.1BM	
D401	DBYV95C—	DIODE	BYV95C (TAPPING)	
D402	DBYV95C—	DIODE	BYV95C (TAPPING)	
D403	DBYV95C—	DIODE	BYV95C (TAPPING)	
D404	D1N4148—	DIODE	1N4148 (TAPPING)	
D405	D1N4148—	DIODE	1N4148 (TAPPING)	
D406	D1N4148—	DIODE	1N4148 (TAPPING)	
D409	DBYV95C—	DIODE	BYV95C (TAPPING)	
D501	DUZ5R1BM—	DIODE ZENER	UZ-5.1BM	
D502	D1N4148—	DIODE	1N4148 (TAPPING)	
D503	D1N4148—	DIODE	1N4148 (TAPPING)	
D504	D1N4148—	DIODE	1N4148 (TAPPING)	
D505	D1N4148—	DIODE	1N4148 (TAPPING)	
D506	D1N4148—	DIODE	1N4148 (TAPPING)	
D507	D1N4148—	DIODE	1N4148 (TAPPING)	
D508	D1N4148—	DIODE	1N4148 (TAPPING)	
D510	D1N4148—	DIODE	1N4148 (TAPPING)	
D602	D1N4148—	DIODE	1N4148 (TAPPING)	
D603	D1N4148—	DIODE	1N4148 (TAPPING)	
D604	D1N4148—	DIODE	1N4148 (TAPPING)	
D605	D1N4148—	DIODE	1N4148 (TAPPING)	
D701	D1N4148—	DIODE	1N4148 (TAPPING)	
D702	D1N4148—	DIODE	1N4148 (TAPPING)	
D703	D1N4148—	DIODE	1N4148 (TAPPING)	
D704	D1N4148—	DIODE	1N4148 (TAPPING)	
D705	DUZ6R2BM—	DIODE ZENER	UZ-6.2BM 6.2V	
D708	DUZ6R2BM—	DIODE ZENER	UZ-6.2BM 6.2V	
D709	DUZ6R2BM—	DIODE ZENER	UZ-6.2BM 6.2V	
D710	DUZ6R2BM—	DIODE ZENER	UZ-6.2BM 6.2V	
D711	DUZ6R2BM—	DIODE ZENER	UZ-6.2BM 6.2V	
D801	D1S1888—	DIODE	1S1888 (TAPPING)	
D802	D1S1888—	DIODE	1S1888 (TAPPING)	
D803	D1S1888—	DIODE	1S1888 (TAPPING)	
D804	D1S1888—	DIODE	1S1888 (TAPPING)	
D807	DBYV95C—	DIODE	BYV95C (TAPPING)	
D808	DBYV95C—	DIODE	BYV95C (TAPPING)	
D809	DBYV95C—	DIODE	BYV95C (TAPPING)	
D811	DBYV95C—	DIODE	BYV95C (TAPPING)	

LOC.	PART-CODE	PART-NAME	PART TYPE	REMARK
D813	DBYV95C—	DIODE	BYV95C (TAPPING)	
D814	DBYV95C—	DIODE	BYV95C (TAPPING)	
L101	5CPZ100K04	COIL PEAKING	10UH 10.5MM K (LAL04TB)	
L103	5CPZ220K02	COIL PEAKING	22UH K (AXIAL 3.5MM)	
L401	5CPZ109M02	COIL PEAKING	1UH M (AXIAL 3.5MM)	
L501	5CPZ150K02	COIL PEAKING	15UH K (AXIAL 3.5MM)	
L502	5CPZ829K02	COIL PEAKING	8.2UH K (AXIAL 3.5MM)	
L503	5CPZ100K02	COIL PEAKING	10UH K (AXIAL 3.5MM)	
L604	5CPZ829K02	COIL PEAKING	8.2UH K (AXIAL 3.5MM)	
L701	5CPZ689K02	COIL PEAKING	6.8UH K (AXIAL 3.5MM)	
L802	5MC0000100	COIL BEAD	MD-5 (HC-3550)	
RA01	RD-AZ750J-	R CARBON FILM	1/6 75 OHM J	
RA02	RD-AZ101J-	R CARBON FILM	1/6 100 OHM J	
RA03	RD-AZ511J-	R CARBON FILM	1/6 510 OHM J	
RA04	RD-AZ302J-	R CARBON FILM	1/6 3K OHM J	
RA09	RD-AZ470J-	R CARBON FILM	1/6 47 OHM J	
RA11	RD-AZ102J-	R CARBON FILM	1/6 1K OHM J	
RA15	RD-AZ221J-	R CARBON FILM	1/6 220 OHM J	
RO401	RD-AZ124J-	R CARBON FILM	1/6 120K OHM J	
R101	RD-AZ470J-	R CARBON FILM	1/6 47 OHM J	
R102	RD-AZ472J-	R CARBON FILM	1/6 4.7K OHM J	
R103	RD-AZ122J-	R CARBON FILM	1/6 1.2K OHM J	
R104	RD-AZ122J-	R CARBON FILM	1/6 1.2K OHM J	
R105	RD-AZ270J-	R CARBON FILM	1/6 27 OHM J	
R106	RD-AZ123J-	R CARBON FILM	1/6 12K OHM J	
R107	RD-AZ333J-	R CARBON FILM	1/6 33K OHM J	
R108	RD-AZ122J-	R CARBON FILM	1/6 1.2K OHM J	
R109	RD-AZ183J-	R CARBON FILM	1/6 18K OHM J	
R110	RD-AZ182J-	R CARBON FILM	1/6 1.8K OHM J	
R111	RD-AZ104J-	R CARBON FILM	1/6 100K OHM J	
R112	RD-AZ104J-	R CARBON FILM	1/6 100K OHM J	
R113	RD-AZ221J-	R CARBON FILM	1/6 220 OHM J	
R114	RD-AZ563J-	R CARBON FILM	1/6 56K OHM J	
R115	RD-AZ562J-	R CARBON FILM	1/6 5.6K OHM J	
R116	RD-AZ562J-	R CARBON FILM	1/6 5.6K OHM J	
R118	RD-4Z825J-	R CARBON FILM	1/4 8.2M OHM J	
R119	RD-4Z825J-	R CARBON FILM	1/4 8.2M OHM J	
R301	RN-AZ3902F	R METAL FILM	1/6 39K OHM F	
R302	RN-AZ1801F	R METAL FILM	1/6 1.8K OHM F	
R304	RD-4Z189J-	R CARBON FILM	1/4 1.8 OHM J	
R305	RD-4Z189J-	R CARBON FILM	1/4 1.8 OHM J	
R308	RD-AZ302J-	R CARBON FILM	1/6 3K OHM J	
R309	RD-AZ103J-	R CARBON FILM	1/6 10K OHM J	

LOC.	PART-CODE	PART-NAME	PART TYPE	REMARK
R310	RD-4Z392J-	R CARBON FILM	1/4 3.9K OHM J	
R311	RD-AZ102J-	R CARBON FILM	1/6 1K OHM J	
R312	RD-AZ103J-	R CARBON FILM	1/6 10K OHM J	
R313	RD-AZ103J-	R CARBON FILM	1/6 10K OHM J	
R314	RD-4Z223J-	R CARBON FILM	1/4 22K OHM J	
R401	RD-AZ102J-	R CARBON FILM	1/6 1K OHM J	
R402	RD-AZ153J-	R CARBON FILM	1/6 15K OHM J	
R403	RD-AZ479J-	R CARBON FILM	1/6 4.7 OHM J	
R404	RD-AZ101J-	R CARBON FILM	1/6 100 OHM J	
R405	RD-AZ152J-	R CARBON FILM	1/6 1.5K OHM J	
R406	RD-AZ272J-	R CARBON FILM	1/6 2.7K OHM J	
R407	RD-4Z823J-	R CARBON FILM	1/4 82K OHM J	
R410	RD-4Z399J-	R CARBON FILM	1/4 3.9 OHM J	
R411	85801065GY	WIRE COPPER	AWG22 1/0.65 TIN COATING	
R412	85801065GY	WIRE COPPER	AWG22 1/0.65 TIN COATING	
R413	85801065GY	WIRE COPPER	AWG22 1/0.65 TIN COATING	
R414	RD-2Z273J-	R CARBON FILM	1/2 27K OHM J	
R416	RD-AZ303J-	R CARBON FILM	1/6 30K OHM J	
R417	RD-4Z102J-	R CARBON FILM	1/4 1K OHM J	
R418	RD-AZ393J-	R CARBON FILM	1/6 39K OHM J	
R421	RD-AZ472J-	R CARBON FILM	1/6 4.7K OHM J	
R501	RD-AZ102J-	R CARBON FILM	1/6 1K OHM J	
R502	RD-AZ101J-	R CARBON FILM	1/6 100 OHM J	
R503	RD-AZ101J-	R CARBON FILM	1/6 100 OHM J	
R504	RD-AZ181J-	R CARBON FILM	1/6 180 OHM J	
R505	RD-AZ479J-	R CARBON FILM	1/6 4.7 OHM J	
R507	RD-4Z109J-	R CARBON FILM	1/4 1 OHM J	
R508	RD-AZ301J-	R CARBON FILM	1/6 300 OHM J	
R510	RD-AZ222J-	R CARBON FILM	1/6 2.2K OHM J	
R511	RD-AZ101J-	R CARBON FILM	1/6 100 OHM J	
R512	RD-AZ101J-	R CARBON FILM	1/6 100 OHM J	
R513	RD-AZ101J-	R CARBON FILM	1/6 100 OHM J	
R514	RD-AZ104J-	R CARBON FILM	1/6 100K OHM J	
R518	RD-AZ103J-	R CARBON FILM	1/6 10K OHM J	
R519	RD-AZ470J-	R CARBON FILM	1/6 47 OHM J	
R520	RD-AZ203J-	R CARBON FILM	1/6 20K OHM J	
R521	RD-AZ104J-	R CARBON FILM	1/6 100K OHM J	
R524	RD-AZ303J-	R CARBON FILM	1/6 30K OHM J	
R525	RD-AZ121J-	R CARBON FILM	1/6 120 OHM J	
R526	RD-4Z479J-	R CARBON FILM	1/4 4.7 OHM J	
R527	RD-AZ101J-	R CARBON FILM	1/6 100 OHM J	
R528	RD-AZ182J-	R CARBON FILM	1/6 1.8K OHM J	
R529	RD-AZ751J-	R CARBON FILM	1/6 750 OHM J	

LOC.	PART-CODE	PART-NAME	PART TYPE	REMARK
R530	RD-AZ203J-	R CARBON FILM	1/6 20K OHM J	
R531	RD-AZ682J-	R CARBON FILM	1/6 6.8K OHM J	
R532	RD-AZ361J-	R CARBON FILM	1/6 360 OHM J	
R533	RD-AZ472J-	R CARBON FILM	1/6 4.7K OHM J	
R534	RD-AZ103J-	R CARBON FILM	1/6 10K OHM J	
R535	RD-AZ102J-	R CARBON FILM	1/6 1K OHM J	
R536	RD-AZ101J-	R CARBON FILM	1/6 100 OHM J	
R537	RD-AZ241J-	R CARBON FILM	1/6 240 OHM J	
R538	RD-AZ102J-	R CARBON FILM	1/6 1K OHM J	
R539	RD-AZ102J-	R CARBON FILM	1/6 1K OHM J	
R540	RD-AZ101J-	R CARBON FILM	1/6 100 OHM J	
R541	RD-AZ331J-	R CARBON FILM	1/6 330 OHM J	
R542	RD-AZ331J-	R CARBON FILM	1/6 330 OHM J	
R543	RD-AZ331J-	R CARBON FILM	1/6 330 OHM J	
R544	RD-AZ103J-	R CARBON FILM	1/6 10K OHM J	
R545	RD-AZ152J-	R CARBON FILM	1/6 1.5K OHM J	
R601	RD-AZ471J-	R CARBON FILM	1/6 470 OHM J	
R602	RD-AZ561J-	R CARBON FILM	1/6 560 OHM J	
R603	RD-AZ562J-	R CARBON FILM	1/6 5.6K OHM J	
R604	RD-AZ681J-	R CARBON FILM	1/6 680 OHM J	
R605	RD-AZ270J-	R CARBON FILM	1/6 27 OHM J	
R606	RD-AZ391J-	R CARBON FILM	1/6 390 OHM J	
R607	RD-AZ221J-	R CARBON FILM	1/6 220 OHM J	
R608	RD-AZ102J-	R CARBON FILM	1/6 1K OHM J	
R609	RD-AZ221J-	R CARBON FILM	1/6 220 OHM J	
R610	RD-AZ102J-	R CARBON FILM	1/6 1K OHM J	
R611	RD-AZ562J-	R CARBON FILM	1/6 5.6K OHM J	
R612	RD-AZ562J-	R CARBON FILM	1/6 5.6K OHM J	
R613	RD-AZ562J-	R CARBON FILM	1/6 5.6K OHM J	
R614	RD-AZ562J-	R CARBON FILM	1/6 5.6K OHM J	
R615	RD-AZ103J-	R CARBON FILM	1/6 10K OHM J	
R616	RD-AZ102J-	R CARBON FILM	1/6 1K OHM J	
R617	RD-AZ152J-	R CARBON FILM	1/6 1.5K OHM J	
R618	RD-AZ103J-	R CARBON FILM	1/6 10K OHM J	
R619	RD-AZ102J-	R CARBON FILM	1/6 1K OHM J	
R621	RD-AZ223J-	R CARBON FILM	1/6 22K OHM J	
R622	RD-AZ182J-	R CARBON FILM	1/6 1.8K OHM J	
R623	RD-AZ562J-	R CARBON FILM	1/6 5.6K OHM J	
R624	RD-AZ103J-	R CARBON FILM	1/6 10K OHM J	
R626	RD-AZ753J-	R CARBON FILM	1/6 75K OHM J	
R627	RD-AZ104J-	R CARBON FILM	1/6 100K OHM J	
R701	RD-AZ472J-	R CARBON FILM	1/6 4.7K OHM J	
R702	RD-AZ272J-	R CARBON FILM	1/6 2.7K OHM J	

LOC.	PART-CODE	PART-NAME	PART TYPE	REMARK
R703	RD-AZ272J-	R CARBON FILM	1/6 2.7K OHM J	
R705	RD-AZ103J-	R CARBON FILM	1/6 10K OHM J	
R708	RD-AZ103J-	R CARBON FILM	1/6 10K OHM J	
R709	RD-AZ103J-	R CARBON FILM	1/6 10K OHM J	
R710	RD-AZ100J-	R CARBON FILM	1/6 10 OHM J	
R711	RD-AZ333J-	R CARBON FILM	1/6 33K OHM J	
R715	RD-AZ912J-	R CARBON FILM	1/6 9.1K OHM J	
R716	RD-AZ333J-	R CARBON FILM	1/6 33K OHM J	
R717	RD-AZ333J-	R CARBON FILM	1/6 33K OHM J	
R718	RD-AZ333J-	R CARBON FILM	1/6 33K OHM J	
R719	RD-4Z333J-	R CARBON FILM	1/4 33K OHM J	
R727	RD-AZ472J-	R CARBON FILM	1/6 4.7K OHM J	
R728	RD-4Z100J-	R CARBON FILM	1/4 10 OHM J	
R729	RD-AZ333J-	R CARBON FILM	1/6 33K OHM J	
R730	RD-AZ333J-	R CARBON FILM	1/6 33K OHM J	
R731	RD-AZ333J-	R CARBON FILM	1/6 33K OHM J	
R732	RD-AZ472J-	R CARBON FILM	1/6 4.7K OHM J	
R733	RD-AZ472J-	R CARBON FILM	1/6 4.7K OHM J	
R734	RD-AZ472J-	R CARBON FILM	1/6 4.7K OHM J	
R735	RD-AZ472J-	R CARBON FILM	1/6 4.7K OHM J	
R736	RD-AZ472J-	R CARBON FILM	1/6 4.7K OHM J	
R737	RD-AZ472J-	R CARBON FILM	1/6 4.7K OHM J	
R738	RD-AZ222J-	R CARBON FILM	1/6 2.2K OHM J	
R739	RD-AZ222J-	R CARBON FILM	1/6 2.2K OHM J	
R740	RD-AZ222J-	R CARBON FILM	1/6 2.2K OHM J	
R741	RD-AZ102J-	R CARBON FILM	1/6 1K OHM J	
R742	RD-AZ472J-	R CARBON FILM	1/6 4.7K OHM J	
R743	RD-AZ101J-	R CARBON FILM	1/6 100 OHM J	
R744	RD-AZ101J-	R CARBON FILM	1/6 100 OHM J	
R745	RD-AZ103J-	R CARBON FILM	1/6 10K OHM J	
R746	RD-AZ102J-	R CARBON FILM	1/6 1K OHM J	
R747	RD-AZ152J-	R CARBON FILM	1/6 1.5K OHM J	
R748	RD-AZ202J-	R CARBON FILM	1/6 2K OHM J	
R750	RD-AZ101J-	R CARBON FILM	1/6 100 OHM J	
R752	RD-4Z101J-	R CARBON FILM	1/4 100 OHM J	
R753	RD-AZ221J-	R CARBON FILM	1/6 220 OHM J	
R754	RD-AZ103J-	R CARBON FILM	1/6 10K OHM J	
R755	RD-AZ101J-	R CARBON FILM	1/6 100 OHM J	
R756	RD-AZ102J-	R CARBON FILM	1/6 1K OHM J	
R757	RD-AZ102J-	R CARBON FILM	1/6 1K OHM J	
R758	RD-AZ102J-	R CARBON FILM	1/6 1K OHM J	
R760	RD-AZ362J-	R CARBON FILM	1/6 3.6K OHM J	
R761	RD-AZ472J-	R CARBON FILM	1/6 4.7K OHM J	

LOC.	PART-CODE	PART-NAME	PART TYPE	REMARK
R762	RD-AZ103J-	R CARBON FILM	1/6 10K OHM J	
R763	RD-AZ101J-	R CARBON FILM	1/6 100 OHM J	
R764	RD-AZ101J-	R CARBON FILM	1/6 100 OHM J	
R765	RD-AZ102J-	R CARBON FILM	1/6 1K OHM J	
R766	RD-AZ104J-	R CARBON FILM	1/6 100K OHM J	
R767	RD-AZ471J-	R CARBON FILM	1/6 470 OHM J	
R807	RD-4Z330J-	R CARBON FILM	1/4 33 OHM J	
R808	RD-4Z182J-	R CARBON FILM	1/4 1.8K OHM J	
R810	RD-4Z104J-	R CARBON FILM	1/4 100K OHM J	
R813	RD-4Z102J-	R CARBON FILM	1/4 1K OHM J	
R826	RD-AZ102J-	R CARBON FILM	1/6 1K OHM J	
R829	RD-4Z472J-	R CARBON FILM	1/4 4.7K OHM J	
R830	RD-4Z103J-	R CARBON FILM	1/4 10K OHM J	
R831	RD-AZ153J-	R CARBON FILM	1/6 15K OHM J	
R832	RD-AZ104J-	R CARBON FILM	1/6 100K OHM J	
R833	RD-4Z101J-	R CARBON FILM	1/4 100 OHM J	
R834	RD-4Z362J-	R CARBON FILM	1/4 3.6K OHM J	
R835	RC-2Z565J-	R CARBON COMP	1/2 5.6M OHM J	
R901	RD-AZ302J-	R CARBON FILM	1/6 3K OHM J	
R902	RD-AZ302J-	R CARBON FILM	1/6 3K OHM J	
R903	RD-AZ302J-	R CARBON FILM	1/6 3K OHM J	
R904	RD-AZ202J-	R CARBON FILM	1/6 2K OHM J	
R905	RD-AZ202J-	R CARBON FILM	1/6 2K OHM J	
R906	RD-AZ202J-	R CARBON FILM	1/6 2K OHM J	
R907	RD-4Z104J-	R CARBON FILM	1/4 100K OHM J	
R908	RD-4Z104J-	R CARBON FILM	1/4 100K OHM J	
R909	RD-4Z104J-	R CARBON FILM	1/4 100K OHM J	
R910	RD-2Z152J-	R CARBON FILM	1/2 1.5K OHM J	
R911	RD-2Z152J-	R CARBON FILM	1/2 1.5K OHM J	
R912	RD-2Z152J-	R CARBON FILM	1/2 1.5K OHM J	

FRONT A/V PART LIST (OPTION)

LOC.	PART-CODE	PART-NAME	PART-DESCRIPTION	REMARK
J177	85801065GY-	WIRE COPPER	AWG22 1/0.65 TIN COATING	Not Used
J121	85801065GY-	WIRE COPPER	AWG22 1/0.65 TIN COATING	
J124	85801065GY-	WIRE COPPER	AWG22 1/0.65 TIN COATING	
J125	85801065GY-	WIRE COPPER	AWG22 1/0.65 TIN COATING	
J136	85801065GY-	WIRE COPPER	AWG22 1/0.65 TIN COATING	
J137	85801065GY-	WIRE COPPER	AWG22 1/0.65 TIN COATING	
DA10	DU1Z9R1BM-	DIODE ZENER	UZ-9.1BM	
DA11	DU1Z9R1BM-	DIODE ZENER	UZ-9.1BM	

LOC.	PART-CODE	PART-NAME	PART-DESCRIPTION	REMARK
R625	RD-AZ221J-	R CARBON FILM	1/4 220 OHM J	
R628	RD-AZ221J-	R CARBON FILM	1/4 220 OHM J	
C621	CEXF1E470V	C ELECTRO	25V RSS 47MF	
C623	CEXF1E470V	C ELECTRO	25V RSS 47MF	
P603	4859231725	CONN WAFER	YW025-04 (STICK)	
PA603	4850704S03	CONN ASS'Y	YH025-04+YST025+TURE=300	
JV02	4859108350	JACK PIN BOARD	YSC-02P-4100-14A	
HP01	4859102130	JACK EARPHONE	YSC-1537	

■ Q / T Difference Part List

NO	LOC	PART NAME	Q MODEL(1spk)	T MODEL(2spk)
1	I601	IC AMP	TDA 7056	TDA 1519B
2	I601A	HEAT SINK	4857025400(A1050P-H24 T2)	4857026402(AL EX BK)
3	PA601	CONN AS	YH025-03+YST025+ULW=200	YH025-03+YST025+ULW=300
4	PA602	CONN AS	-	YH025-03+YST025+ULW=600
5	SP01	SPEAKER	3W 16Ω F2035C03-3	7.5W 8Ω 95BF03LC
6	SP02	SPEAKER	-	95BF03LC
7	P602	CONN WAFER	-	YW025-03(STICK)
8	C613	C CERA	25V 0.01μF Z(AXIAL)	-
9	J175,J207,J209 J210,J212,J214	WIRE COPPER	-	AWG22 1/0.65 TIN COATING
10	J176,J205,J206 J208,J211,J213 J215	WIRE COPPER	AWG22 1/0.65 TIN COATING	-
11	R620	R CARBON	-	1/6W 56KΩ
12	C620	C MYLAR	-	100V 0.1μF J
13	C612	C MYLAR	-	100V 0.022μF J
14	C619	C ELECTRO	-	50V RSS 47MF
15	R621	R CARBON	1/6W 22K	1/6W 18K

■ CP-370 Inch Difference Part List

NO	LOC	PART NAME	14" MODEL	20" MODEL	21" MODEL	REMARK
1	R407	R-CARBON	1/4W 82K	1/4W 68K	1/4W 68K	ABL
2	C410	C-MYLAR	1.6KV 6900PF	1.6KV 7500PF J	1.6KV 6000PF	H.V
3	C411	C-MYLAR	200V 0.33MF J	200V 0.36MF J	200V 0.3MF	H.V
4	R415	R-FUSIBLE	1W 1.2OHM	1W 2.2OHM	1W 1.2OHM	HEATER
5	R901	R-CARBON	1/6W 3K	1/6W 2K	1/6W 2K	R, G, B
6	R902	R-CARBON	1/6W 3K	1/6W 2K	1/6W 2K	R, G, B
7	R903	R-CARBON	1/6W 3K	1/6W 2K	1/6W 2K	R, G, B
8	R904	R-CARBON	1/6W 2K	1/6W 1.6K	1/6W 1.6K	R, G, B
9	R905	R-CARBON	1/6W 2K	1/6W 1.6K	1/6W 1.6K	R, G, B
10	R906	R-CARBON	1/6W 2K	1/6W 1.6K	1/6W 1.6K	R, G, B
11	R834	R-CARBON	1/4W 3.6K	1/4W 3.3K	1/4W 3.3K	-
12	L901	COIL/D	DC-1450	DC-2050	DC-2070	-
13	13100	CRT GND AS	1401H-1015-1P	2001H-1015-1P	2101H-1015-1P	-
14	V801	CRT BARE	A34JLL90X	A48JLL90X	A51JLL90X	-
15	CRT1	CRT AS	14Q1VM	20Q1VM	21Q1VM	-
16	J187	WIRE COPPER	-	-	WIRE COPPER	B+:110V
17	J218	WIRE COPPER	WIRE COPPER	WIRE COPPER	-	B+:123V
18	R302	R-CARBON	1/6W 1.8K	1/6W 2.0K	1/6W 2.4K	V-SIZE(1%R)
19	P401	WAFER	YFW-500-05	YFW500-05	YFW500-06	D.Y

CP-370 CHASSIS SCHEMATIC DIAGRAM VM.TM

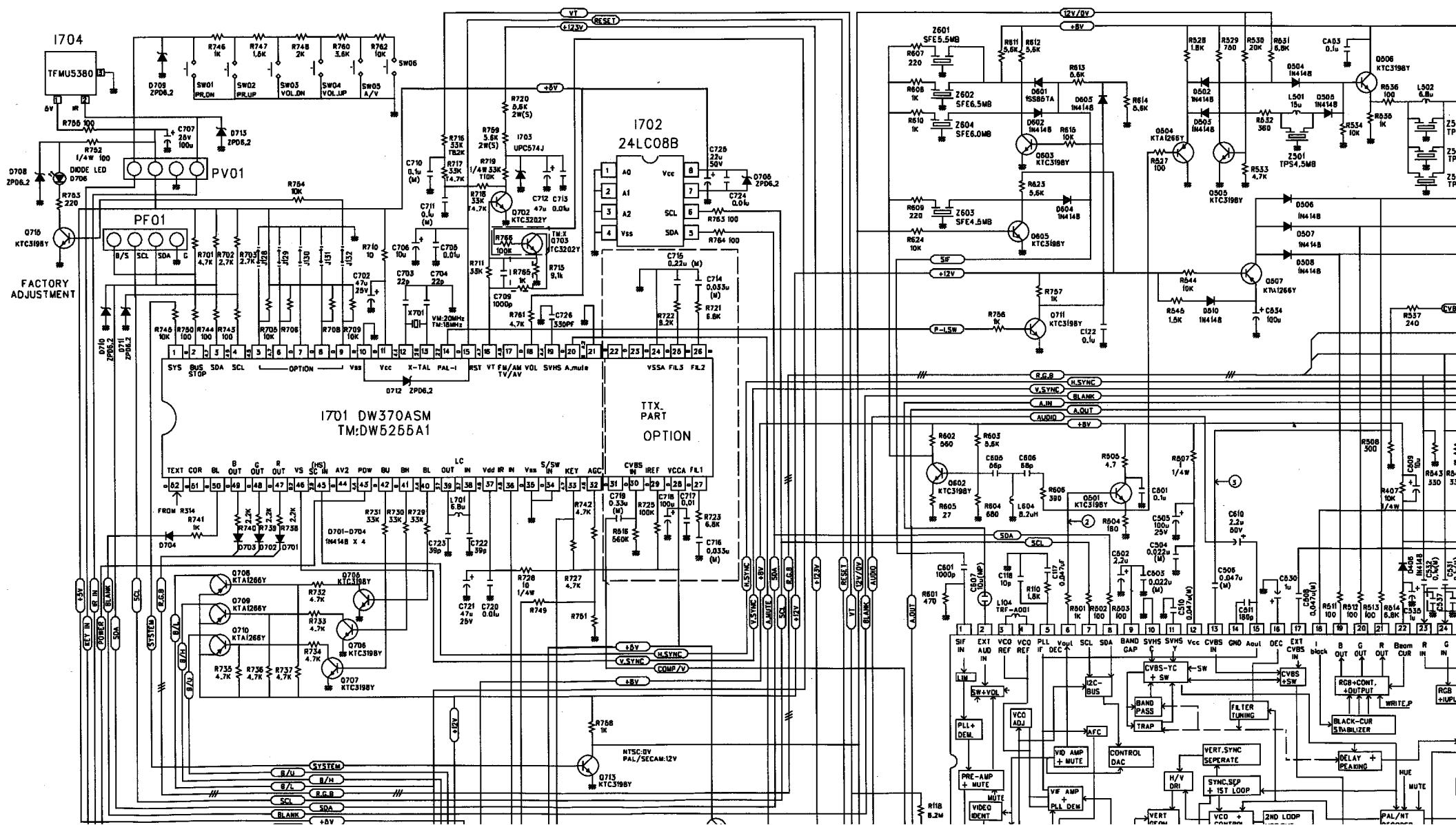

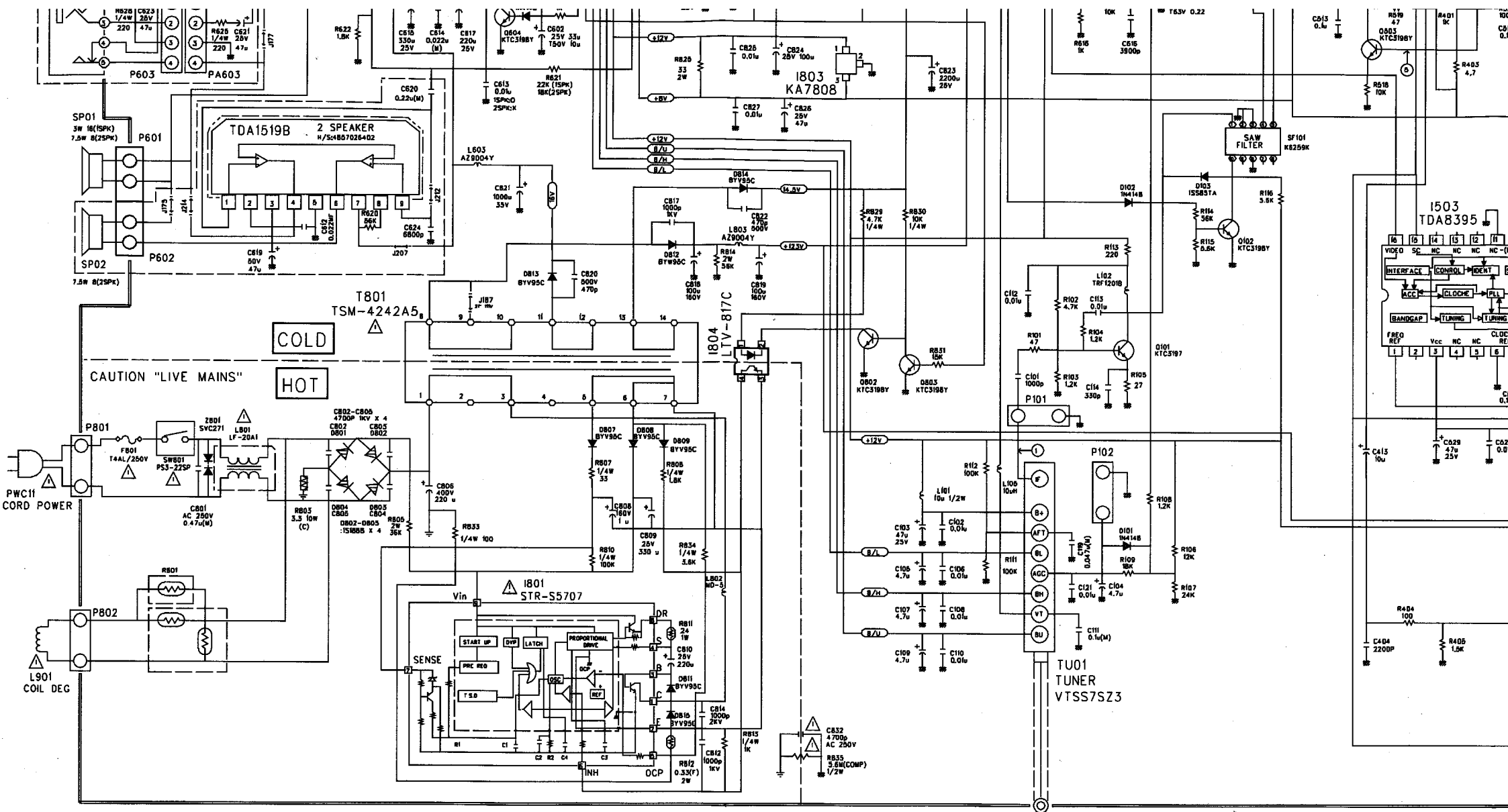

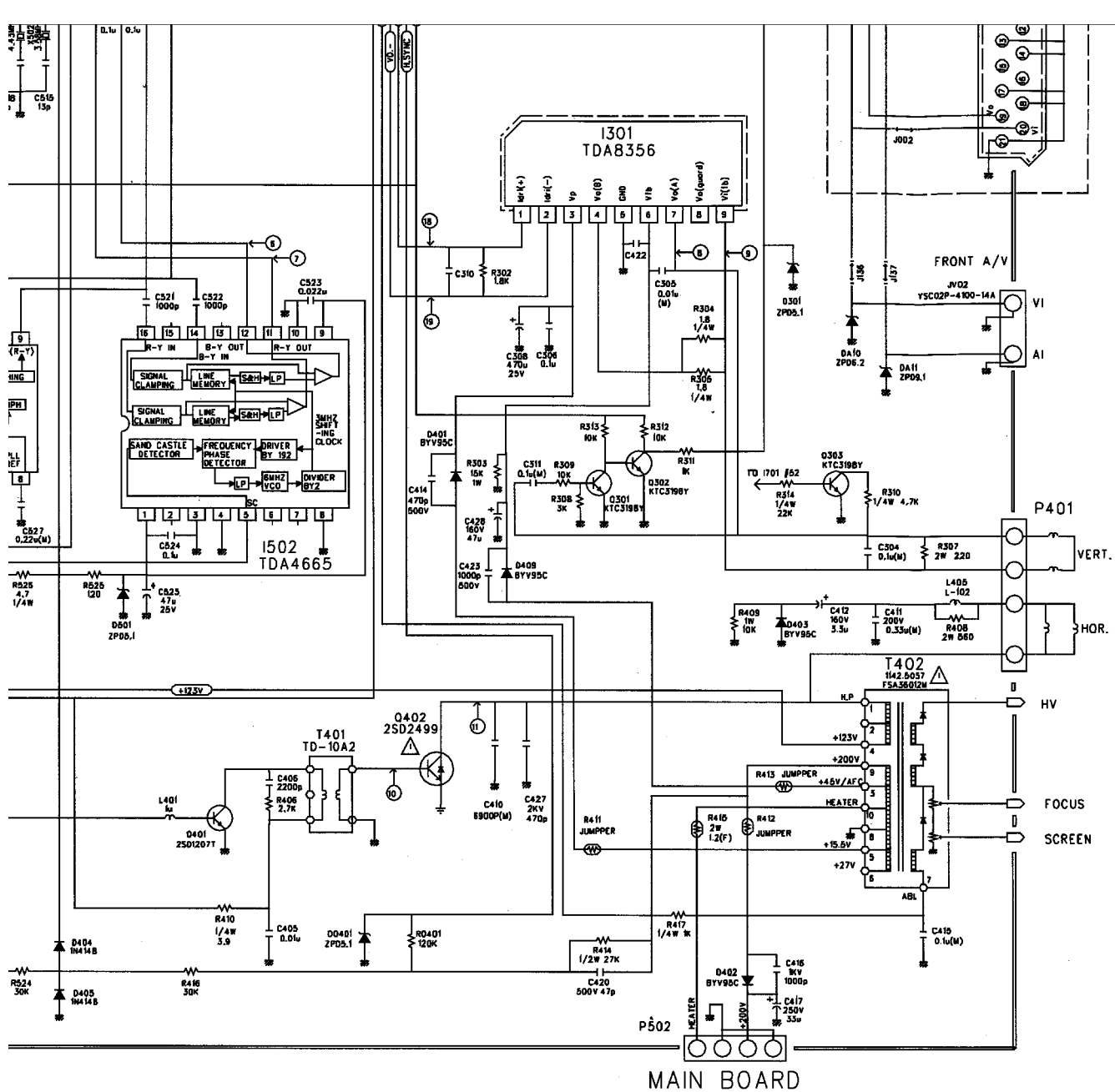

4	C411	200V 0.33uF	200V 0.36uF	200V 0.30uF
5	R302	1/6W 1.8K	1/6W 2.2K	1/6W 2.4K
6	R407	1/4W 10K	1/4W 8.2K	1/4W 7.5K
7	R415	1W 1.2 (F)	1W 2.2 (F)	1W 1.2 (F)
8	R834	1/4W 3.6K	1/4W 3.3K	1/4W 3.3K
9	J187	-	-	-
10	J218	WIRE COPPER	WIRE COPPER	-
11	GND AS	1401H-1015-1P	2001H-1015-1P	2101H-1015-1P
12	P401	YFW500-05	YFW500-05	YFW500-06
13				
14				
15				
16				
17				
18				
19				
20				

* WAVE FORMS

VIDEO :8 STEP PAL COLOR BAR 87.5% AM
 AUDIO :1KHz SINE WAVE 60% FM

