



Website:<http://biz.LGservice.com>
E-mail:<http://www.LGService.com/techsup.html>

COLOR MONITOR SERVICE MANUAL

CHASSIS NO. : CL-32

MODEL: FLATRON L1515S (L1515SL-AL**R)

FLATRON L1516S (L1516SL-AL**R)

() **Same model for Service

CAUTION

BEFORE SERVICING THE UNIT,
READ THE **SAFETY PRECAUTIONS** IN THIS MANUAL.

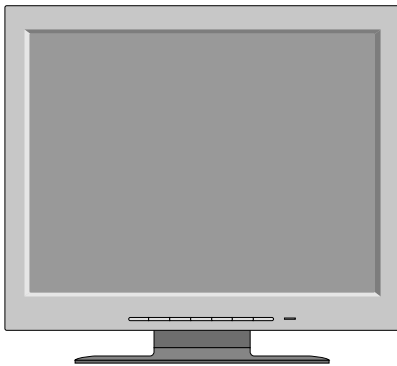

*To apply the **Mstar Chip**.

PIN CONFIGURATION

MST9011 ANALOG MSTAR 128P

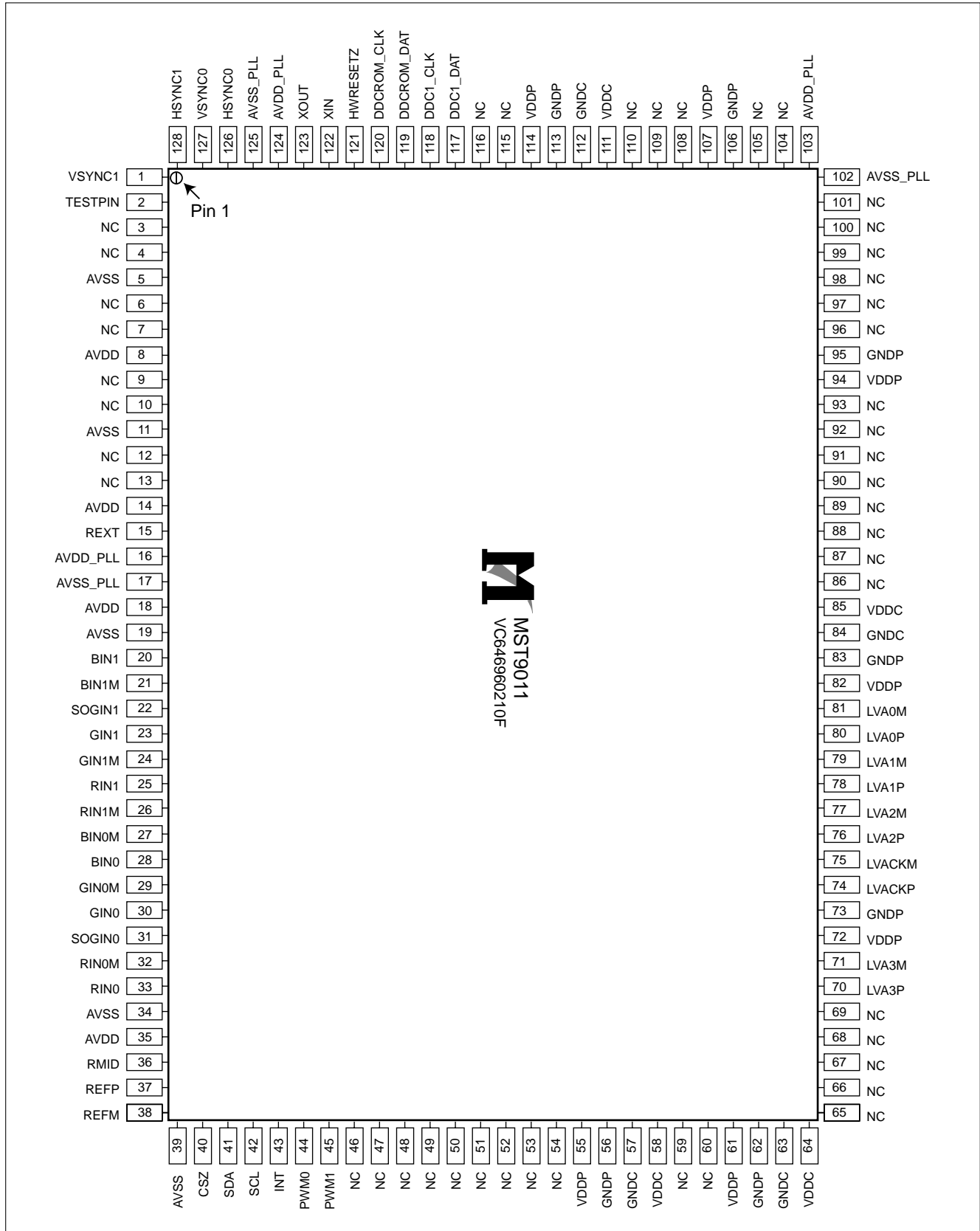

SCHEMATIC DIAGRAM

1. SCALER

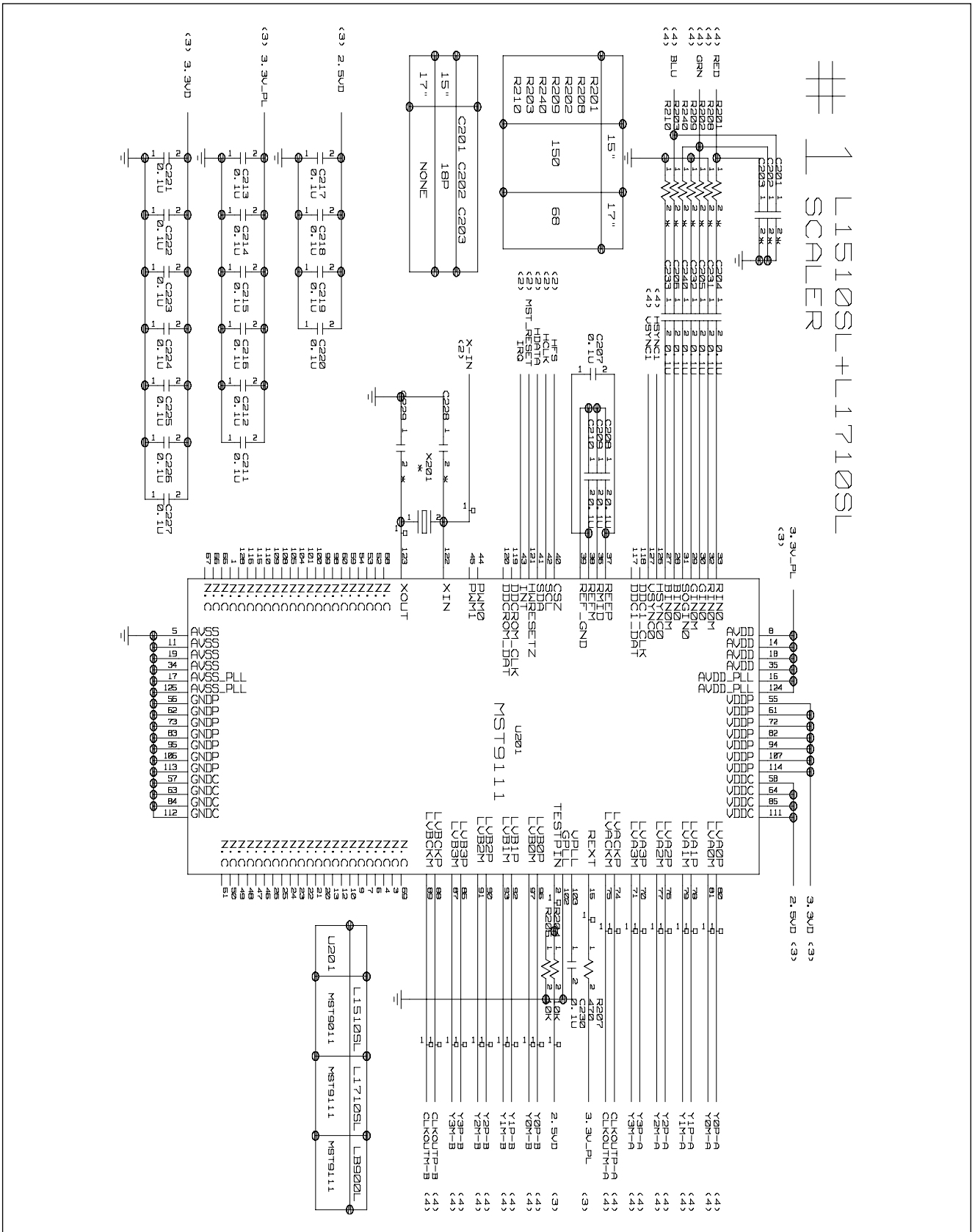

3. POWER

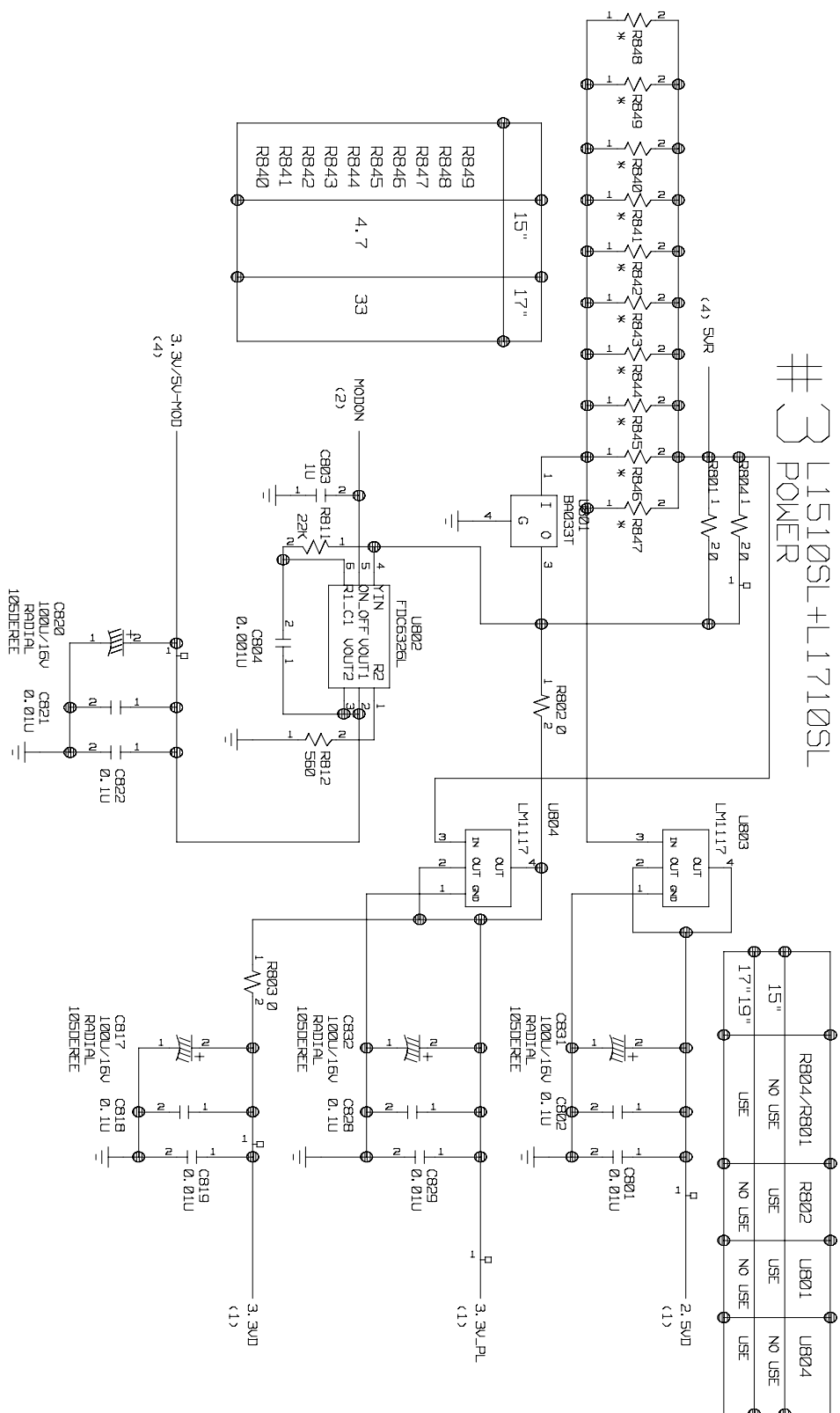

4. CONNECTOR & JACKS

#4 USB15SLFOR1715SL

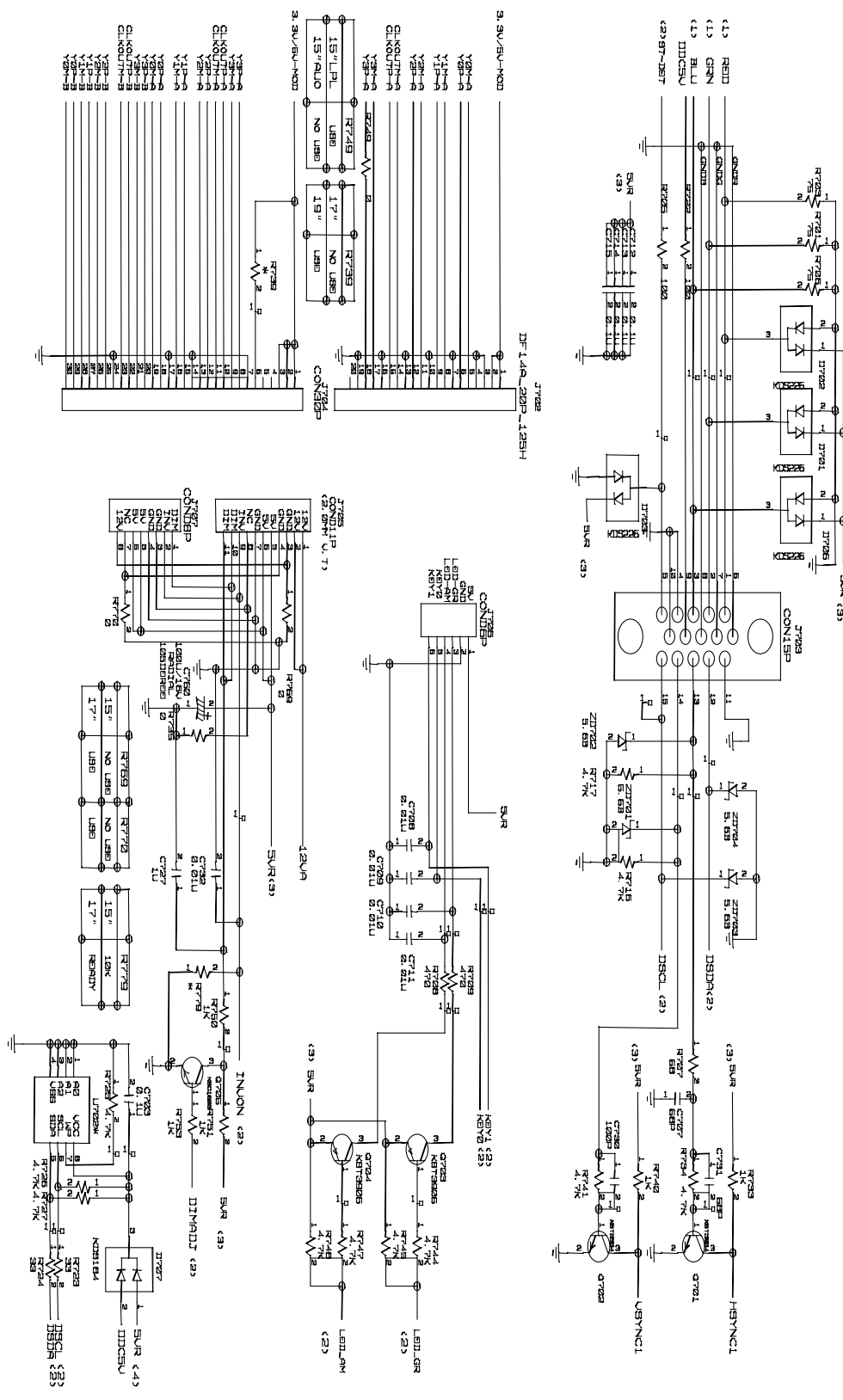

5. KEY PART

L1515SL KEY PART

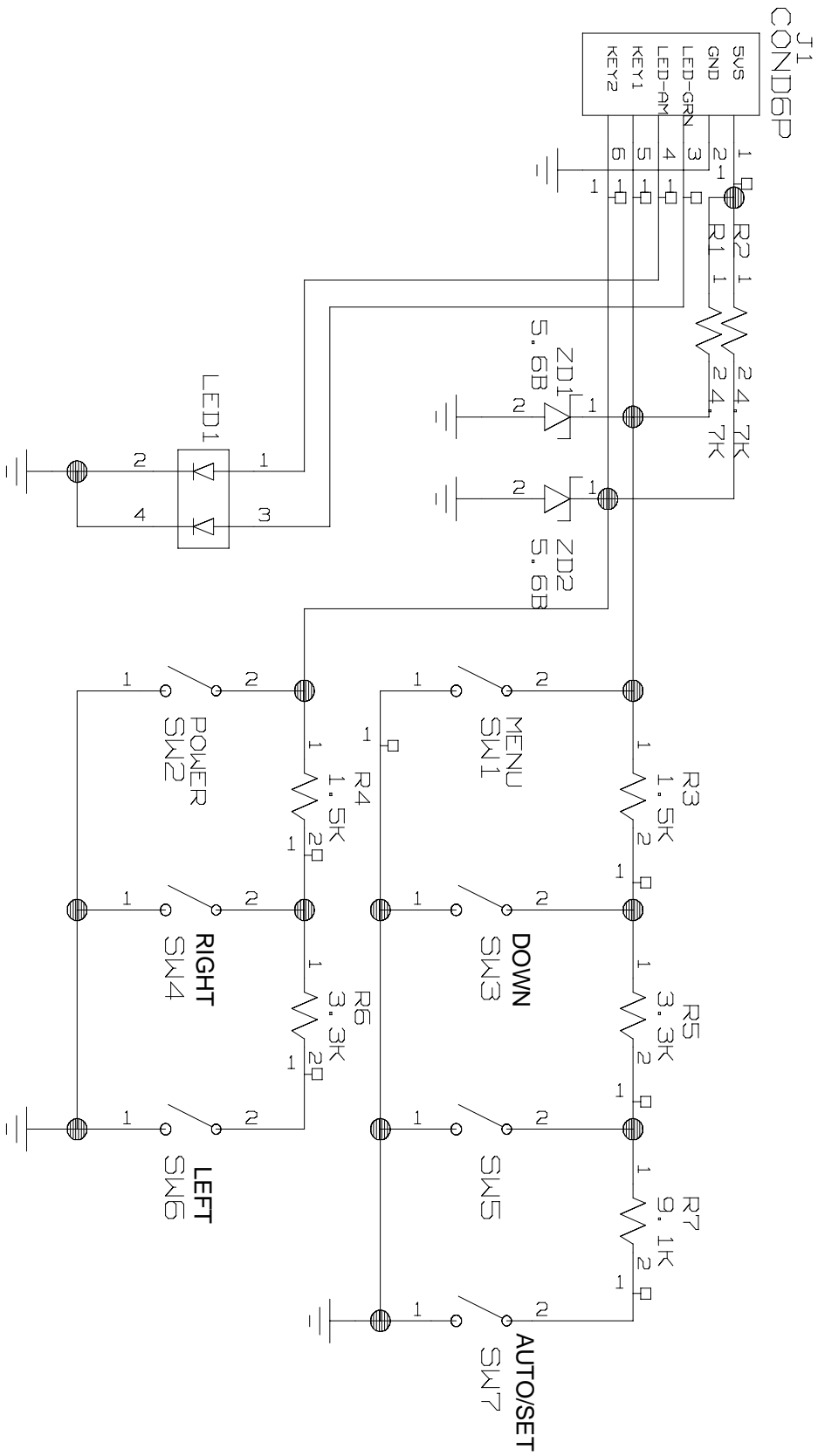

6. Lips#1

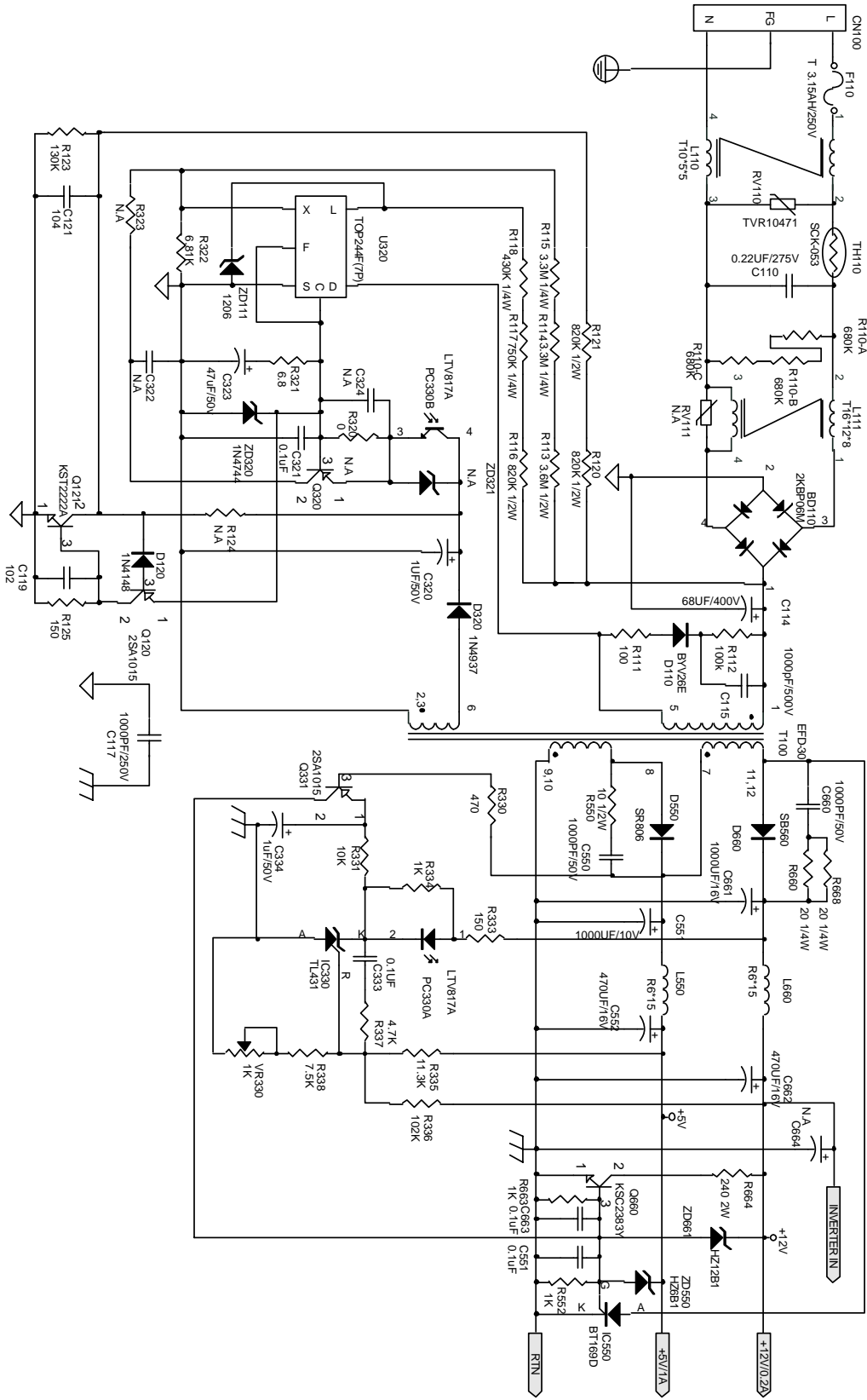



P/NO : 3828TSL083X

May. 2003
Printed in Korea

