



SERVICE MANUAL

MODEL : DK676X/DK677X



DVD VIDEO PLAYER

SERVICE MANUAL

MODEL : DK676X/DK677X

CAUTION

BEFORE SERVICING THE UNIT, READ THE "SAFETY PRECAUTIONS" IN THIS MANUAL.



LG Electronics Inc.

CONTENTS

SECTION 1 SUMMARY

SECTION 2 CABINET & MAIN CHASSIS

SECTION 3 ELECTRICAL

SECTION 4 REPLACEMENT PARTS LIST

SECTION 1

SUMMARY

CONTENTS

PRODUCT SAFETY SERVICING GUIDELINES FOR VIDEO PRODUCTS	1-3
SERVICING PRECAUTIONS	1-4
• General Servicing Precautions	
• Insulation Checking Prodedure	
• Electrostatically Sensitive Devices	
SERVICE INFORMATION FOR EEPROM	1-5
SPECIFICATIONS	1-6

PRODUCT SAFETY SERVICING GUIDELINES FOR VIDEO PRODUCTS

CAUTION : DO NOT ATTEMPT TO MODIFY THIS PRODUCT IN ANY WAY, NEVER PERFORM CUSTOMIZED INSTALLATIONS WITHOUT MANUFACTURER'S APPROVAL. UNAUTHORIZED MODIFICATIONS WILL NOT ONLY VOID THE WARRANTY, BUT MAY LEAD TO YOUR BEING LIABLE FOR ANY RESULTING PROPERTY DAMAGE OR USER INJURY.

SERVICE WORK SHOULD BE PERFORMED ONLY AFTER YOU ARE THOROUGHLY FAMILIAR WITH ALL OF THE FOLLOWING SAFETY CHECKS AND SERVICING GUIDELINES. TO DO OTHERWISE, INCREASES THE RISK OF POTENTIAL HAZARDS AND INJURY TO THE USER.

WHILE SERVICING, USE AN ISOLATION TRANSFORMER FOR PROTECTION FROM A.C. LINE SHOCK.

SAFETY CHECKS

AFTER THE ORIGINAL SERVICE PROBLEM HAS BEEN CORRECTED, A CHECK SHOULD BE MADE OF THE FOLLOWING.

SUBJECT : FIRE & SHOCK HAZARD

1. BE SURE THAT ALL COMPONENTS ARE POSITIONED IN SUCH A WAY AS TO AVOID POSSIBILITY OF ADJACENT COMPONENT SHORTS. THIS IS ESPECIALLY IMPORTANT ON THOSE MODULES WHICH ARE TRANSPORTED TO AND FROM THE REPAIR SHOP.
2. NEVER RELEASE A REPAIR UNLESS ALL PROTECTIVE DEVICES SUCH AS INSULATORS, BARRIERS, COVERS, SHIELDS, STRAIN RELIEFS, POWER SUPPLY CORDS, AND OTHER HARDWARE HAVE BEEN REINSTALLED PER ORIGINAL DESIGN. BE SURE THAT THE SAFETY PURPOSE OF THE POLARIZED LINE PLUG HAS NOT BEEN DEFEATED.
3. SOLDERING MUST BE INSPECTED TO DISCOVER POSSIBLE COLD SOLDER JOINTS, SOLDER SPLASHES OR SHARP SOLDER POINTS. BE CERTAIN TO REMOVE ALL LOOSE FOREIGN PARTICLES.
4. CHECK FOR PHYSICAL EVIDENCE OF DAMAGE OR DETERIORATION TO PARTS AND COMPONENTS. FOR FRAYED LEADS, DAMAGED INSULATION (INCLUDING A.C. CORD), AND REPLACE IF NECESSARY FOLLOW ORIGINAL LAYOUT, LEAD LENGTH AND DRESS.
5. NO LEAD OR COMPONENT SHOULD TOUCH A RECEIVING TUBE OR A RESISTOR RATED AT 1 WATT OR MORE. LEAD TENSION AROUND PROTRUDING METAL SURFACES MUST BE AVOIDED.
6. ALL CRITICAL COMPONENTS SUCH AS FUSES, FLAMEPROOF RESISTORS, CAPACITORS, ETC. MUST BE REPLACED WITH EXACT FACTORY TYPES, DO NOT USE REPLACEMENT COMPONENTS OTHER THAN THOSE SPECIFIED OR MAKE UNRECOMMENDED CIRCUIT MODIFICATIONS.
7. AFTER RE-ASSEMBLY OF THE SET ALWAYS PERFORM AN A.C. LEAKAGE TEST ON ALL EXPOSED METALLIC PARTS OF THE CABINET, (THE CHANNEL SELECTOR KNOB, ANTENNA TERMINALS, HANDLE AND SCREWS) TO BE SURE THE SET IS SAFE TO OPERATE WITHOUT DANGER OF ELECTRICAL SHOCK. DO NOT USE A LINE ISOLATION TRANSFORMER DURING THIS TEST USE AN A.C. VOLT-METER, HAVING 5000 OHMS PER VOLT OR MORE SENSITIVITY, IN THE FOLLOWING MANNER; CONNECT A 1500 OHM 10 WATT RESISTOR, PARALLELED BY A .15 MFD. 150.V A.C TYPE CAPACITOR BETWEEN A KNOWN GOOD EARTH GROUND (WATER PIPE, CONDUIT, ETC.) AND THE EXPOSED METALLIC PARTS, ONE AT A TIME. MEASURE THE A.C. VOLTAGE ACROSS THE COMBINATION OF 1500 OHM RESISTOR AND .15 MFD CAPACITOR. REVERSE THE A.C. PLUG AND REPEAT A.C. VOLTAGE MEASUREMENTS FOR EACH EXPOSED METALLIC PART. VOLTAGE MEASURED MUST NOT EXCEED 75 VOLTS R.M.S. THIS CORRESPONDS TO 0.5 MILLIAMPS A.C ANY VALUE EXCEEDING THIS LIMIT CONSTITUTES A POTENTIAL SHOCK HAZARD AND MUST BE CORRECTED IMMEDIATELY.

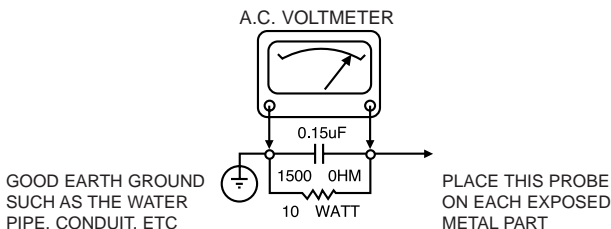

SUBJECT: GRAPHIC SYMBOLS



THE LIGHTNING FLASH WITH ARROWHEAD SYMBOL, WITHIN AN EQUILATERAL TRIANGLE, IS INTENDED TO ALERT THE SERVICE PERSONNEL TO THE PRESENCE OF UNINSULATED "DANGEROUS VOLTAGE" THAT MAY BE OF SUFFICIENT MAGNITUDE TO CONSTITUTE A RISK OF ELECTRIC SHOCK.



THE EXCLAMATION POINT WITHIN AN EQUILATERAL TRIANGLE IS INTENDED TO ALERT THE SERVICE PERSONNEL TO THE PRESENCE OF IMPORTANT SAFETY INFORMATION IN SERVICE LITERATURE.

SUBJECT : X-RADIATION

1. BE SURE PROCEDURES AND INSTRUCTIONS TO ALL SERVICE PERSONNEL COVER THE SUBJECT OF X-RADIATION. THE ONLY POTENTIAL SOURCE OF X-RAYS IN CURRENT T.V. RECEIVERS IS THE PICTURE TUBE. HOWEVER, THIS TUBE DOES NOT EMIT X-RAYS WHEN THE HIGH VOLTAGE IS AT THE FACTORY SPECIFIED LEVEL. THE PROPER VALUE IS GIVEN IN THE APPLICABLE SCHEMATIC. OPERATION AT HIGHER VOLTAGES MAY CAUSE A FAILURE OF THE PICTURE TUBE OR HIGH VOLTAGE SUPPLY AND, UNDER CERTAIN CIRCUMSTANCES, MAY PRODUCE RADIATION IN EXCESS OF DESIRABLE LEVELS.
2. ONLY FACTORY SPECIFIED C.R.T. ANODE CONNECTORS MUST BE USED. DEGAUSSING SHIELDS ALSO SERVE AS X-RAY SHIELD IN COLOR SETS, ALWAYS RE-INSTALL THEM.
3. IT IS ESSENTIAL THAT SERVICE PERSONNEL HAVE AVAILABLE AN ACCURATE AND RELIABLE HIGH VOLTAGE METER. THE CALIBRATION OF THE METER SHOULD BE CHECKED PERIODICALLY AGAINST A REFERENCE STANDARD, SUCH AS THE ONE AVAILABLE AT YOUR DISTRIBUTOR.
4. WHEN THE HIGH VOLTAGE CIRCUITRY IS OPERATING PROPERLY THERE IS NO POSSIBILITY OF AN X-RADIATION PROBLEM. EVERY TIME A COLOR CHASSIS IS SERVICED, THE BRIGHTNESS SHOULD BE RUN UP AND DOWN WHILE MONITORING THE HIGH VOLTAGE WITH A METER TO BE CERTAIN THAT THE HIGH VOLTAGE DOES NOT EXCEED THE SPECIFIED VALUE AND THAT IT IS REGULATING CORRECTLY, WE SUGGEST THAT YOU AND YOUR SERVICE ORGANIZATION REVIEW TEST PROCEDURES SO THAT VOLTAGE REGULATION IS ALWAYS CHECKED AS A STANDARD SERVICING PROCEDURE. AND THAT THE HIGH VOLTAGE READING BE RECORDED ON EACH CUSTOMER'S INVOICE.
5. WHEN TROUBLESHOOTING AND MAKING TEST MEASUREMENTS IN A PRODUCT WITH A PROBLEM OF EXCESSIVE HIGH VOLTAGE, AVOID BEING UNNECESSARILY CLOSE TO THE PICTURE TUBE AND THE HIGH VOLTAGE SUPPLY. DO NOT OPERATE THE PRODUCT LONGER THAN IS NECESSARY TO LOCATE THE CAUSE OF EXCESSIVE VOLTAGE.
6. REFER TO HV. B+ AND SHUTDOWN ADJUSTMENT PROCEDURES DESCRIBED IN THE APPROPRIATE SCHEMATIC AND DIAGRAMS (WHERE USED).

SUBJECT: IMPLOSION

1. ALL DIRECT VIEWED PICTURE TUBES ARE EQUIPPED WITH AN INTEGRAL IMPLOSION PROTECTION SYSTEM, BUT CARE SHOULD BE TAKEN TO AVOID DAMAGE DURING INSTALLATION, AVOID SCRATCHING THE TUBE. IF SCRATCHED REPLACE IT.
2. USE ONLY RECOMMENDED FACTORY REPLACEMENT TUBES.

SUBJECT : TIPS ON PROPER INSTALLATION

1. NEVER INSTALL ANY PRODUCT IN A CLOSED-IN RECESS, CUBBY-HOLE OR CLOSELY FITTING SHELF SPACE. OVER OR CLOSE TO HEAT DUCT, OR IN THE PATH OF HEATED AIR FLOW.
2. AVOID CONDITIONS OF HIGH HUMIDITY SUCH AS: OUTDOOR PATIO INSTALLATIONS WHERE DEW IS A FACTOR, NEAR STEAM RADIATORS WHERE STEAM LEAKAGE IS A FACTOR, ETC.
3. AVOID PALCEMENT WHERE DRAPERIES MAY OBSTRUCT REAR VENTING. THE CUSTOMER SHOULD ALSO AVOID THE USE OF DECORATIVE SCARVES OR OTHER COVERINGS WHICH MIGHT OBSTRUCT VENTILATION.
4. WALL AND SHELF MOUNTED INSTALLATIONS USING A COMMERCIAL MOUNTING KIT, MUST FOLLOW THE FACTORY APPROVED MOUNTING INSTRUCTIONS A PRODUCT MOUNTED TO A SHELF OR PLATFORM MUST RETAIN ITS ORIGINAL FEET (OR THE EQUIVALENT THICKNESS IN SPACERS) TO PROVIDE ADEQUATE AIR FLOW ACROSS THE BOTTOM, BOLTS OR SCREWS USED FOR FASTENERS MUST NOT TOUCH ANY PARTS OR WIRING. PERFORM LEAKAGE TEST ON CUSTOMIZED INSTALLATIONS.
5. CAUTION CUSTOMERS AGAINST THE MOUNTING OF A PRODUCT ON SLOPING SHELF OR A TILTED POSITION, UNLESS THE PRODUCT IS PROPERLY SECURED.
6. A PRODUCT ON A ROLL-ABOUT CART SHOULD BE STABLE ON ITS MOUNTING TO THE CART. CAUTION THE CUSTOMER ON THE HAZARDS OF TRYING TO ROLL A CART WITH SMALL CASTERS ACROSS THRESHOLDS OR DEEP PILE CARPETS.
7. CAUTION CUSTOMERS AGAINST THE USE OF A CART OR STAND WHICH HAS NOT BEEN LISTED BY UNDERWRITERS LABORATORIES, INC. FOR USE WITH THEIR SPECIFIC MODEL OF TELEVISION RECEIVER OR GENERALLY APPROVED FOR USE WITH T.V.'S OF THE SAME OR LARGER SCREEN SIZE.
8. CAUTION CUSTOMERS AGAINST THE USE OF EXTENSION CORDS, EXPLAIN THAT A FOREST OF EXTENSIONS SPROUTING FROM A SINGLE OUTLET CAN LEAD TO DISASTROUS CONSEQUENCES TO HOME AND FAMILY.

SERVICING PRECAUTIONS

CAUTION : Before servicing the DVD covered by this service data and its supplements and addends, read and follow the **SAFETY PRECAUTIONS**. **NOTE** : if unforeseen circumstances create conflict between the following servicing precautions and any of the safety precautions in this publication, always follow the safety precautions.

Remembers Safety First:

General Servicing Precautions

1. Always unplug the DVD AC power cord from the AC power source before:
 - (1) Removing or reinstalling any component, circuit board, module, or any other assembly.
 - (2) Disconnection or reconnecting any internal electrical plug or other electrical connection.
 - (3) Connecting a test substitute in parallel with an electrolytic capacitor.
Caution : A wrong part substitution or incorrect polarity installation of electrolytic capacitors may result in an explosion hazard.
2. Do not spray chemicals on or near this DVD or any of its assemblies.
3. Unless specified otherwise in this service data, clean electrical contacts by applying an appropriate contact cleaning solution to the contacts with a pipe cleaner, cotton-tipped swab, or comparable soft applicator. Unless specified otherwise in this service data, lubrication of contacts is not required.
4. Do not defeat any plug/socket B+ voltage interlocks with which instruments covered by this service manual might be equipped.
5. Do not apply AC power to this DVD and/or any of its electrical assemblies unless all solid-state device heat sinks are correctly installed.
6. Always connect test instrument ground lead to the appropriate ground before connection the test instrument positive lead. Always remove the test instrument ground lead last.

Insulation Checking Procedure

Disconnect the attachment plug from the AC outlet and turn the power on. Connect an insulation resistance meter(500V) to the blades of the attachment plug. The insulation resistance between each blade of the attachment plug and accessible conductive parts (Note 1) should be more than 1M-ohm.

Note 1 : Accessible Conductive Parts including Metal panels, Input terminals, Earphone jacks, etc.

Electrostatically Sensitive (ES) Devices

Some semiconductor (solid state) devices can be damaged easily by static electricity. Such components commonly are called Electrostatically Sensitive (ES) Devices. Examples of typical ES devices are integrated circuits and some field effect transistors and semiconductor chip components.

The following techniques should be used to help reduce the incidence of component damage caused by static electricity.

1. Immediately before handling any semiconductor component or semiconductor-equipped assembly, drain off any electrostatic charge on your body by touching a known earth ground. Alternatively, obtain and wear a commercially available discharging wrist strap device, which should be removed for potential shock reasons prior to applying power to the unit under test.
2. After removing an electrical assembly equipped with ES devices, place the assembly on a conductive surface such as aluminum foil, to prevent electrostatic charge buildup or exposure of the assembly.
3. Use only a grounded-tip soldering iron to solder or unsolder ES devices.
4. Use only an anti-static solder removal device. Some solder removal devices not classified a "anti-static" can generate electrical charges sufficient to damage ES devices.
5. Do not use freon-propelled chemicals. These can generate electrical charge sufficient to damage ES devices.
6. Do not remove a replacement ES device from its protective package until immediately before you are ready to install it. (Most replacement ES devices are packaged with leads electrically shorted together by conductive foam, aluminum foil, or comparable conductive material).
7. Immediately before removing the protective material from the leads of a replacement ES device, touch the protective material to the chassis or circuit assembly into which the device will be installed.

Caution : Be sure no power is applied to the chassis or circuit, and observe all other safety precautions.

8. Minimize bodily motions when handling unpackaged replacement ES devices. (Normally harmless motion such as the brushing together of your clothes fabric or the lifting of your foot from a carpeted floor can generate static electricity sufficient to damage an ES device.)

SPECIFICATIONS

• GENERAL

Power requirements:	AC 200-240 V , 50/60 Hz
Power consumption:	8W
Dimensions (Approx.):	8, 7, 6 TOOL : 430 x 35 x 242 mm (17 x 1.4 x 9.5 inches) 4, 3 TOOL : 360 x 35 x 242 mm (14.2 x 1.4 x 9.5 inches) (W x H x D) without foot
Weight (Approx.):	8, 7, 6 TOOL : 1.9 kg (4.2 lbs) 4, 3 TOOL : 1.9 kg (4.2 lbs)
Operating temperature:	5 °C to 35 °C (41 °F to 95 °F)
Operating humidity:	5 % to 90 %

• OUTPUTS

VIDEO OUT:	1 V (p-p), 75 Ω, sync negative, RCA jack x 1/SCART (TO TV)
COMPONENT VIDEO OUT:	(Y) 1.0 V (p-p), 75 Ω, negative sync, RCA jack x 1 (Pb)/(Pr) 0.7 V (p-p), 75 Ω, RCA jack x 2
AUDIO OUT:	2.0 Vrms (1 KHz, 0 dB), 600 Ω, RCA jack (L, R) x 1 / SCART(TO TV)
DIGITAL OUT (COAXIAL):	0.5 V (p-p), 75 Ω, RCA jack x 1
DIGITAL OUT (OPTICAL) : (OPTIONAL)	3 V (p-p), 75 Ω, Optical jack x 1

• SYSTEM

Laser:	Semiconductor laser, wavelength 650 nm
Signal system:	PAL / NTSC
Frequency response:	DVD (PCM 96 kHz): 8 Hz to 44 kHz DVD (PCM 48 kHz): 8 Hz to 22 kHz CD: 8 Hz to 20 kHz
Signal-to-noise ratio:	More than 90 dB (ANALOG OUT connectors only)
Harmonic distortion:	Less than 0.02%
Dynamic range:	More than 95 dB (DVD/CD)

SECTION 2
CABINET & MAIN CHASSIS

CONTENTS

EXPLODED VIEWS2-2

- 1. Cabinet and Main Frame Section2-2**
- 2. Deck Mechanism Section(DP-10).....2-3**
- 3. Packing Accessory Section2-4**

EXPLODED VIEWS

1. Cabinet and Main Frame Section

NOTES) THE EXCLAMATION POINT WITHIN AN EQUILATERAL TRIANGLE IS INTENDED TO ALERT THE SERVICE PERSONNEL TO THE PRESENCE OF IMPORTANT SAFETY INFORMATION IN SERVICE LITERATURE.

★ OPTIONAL PART

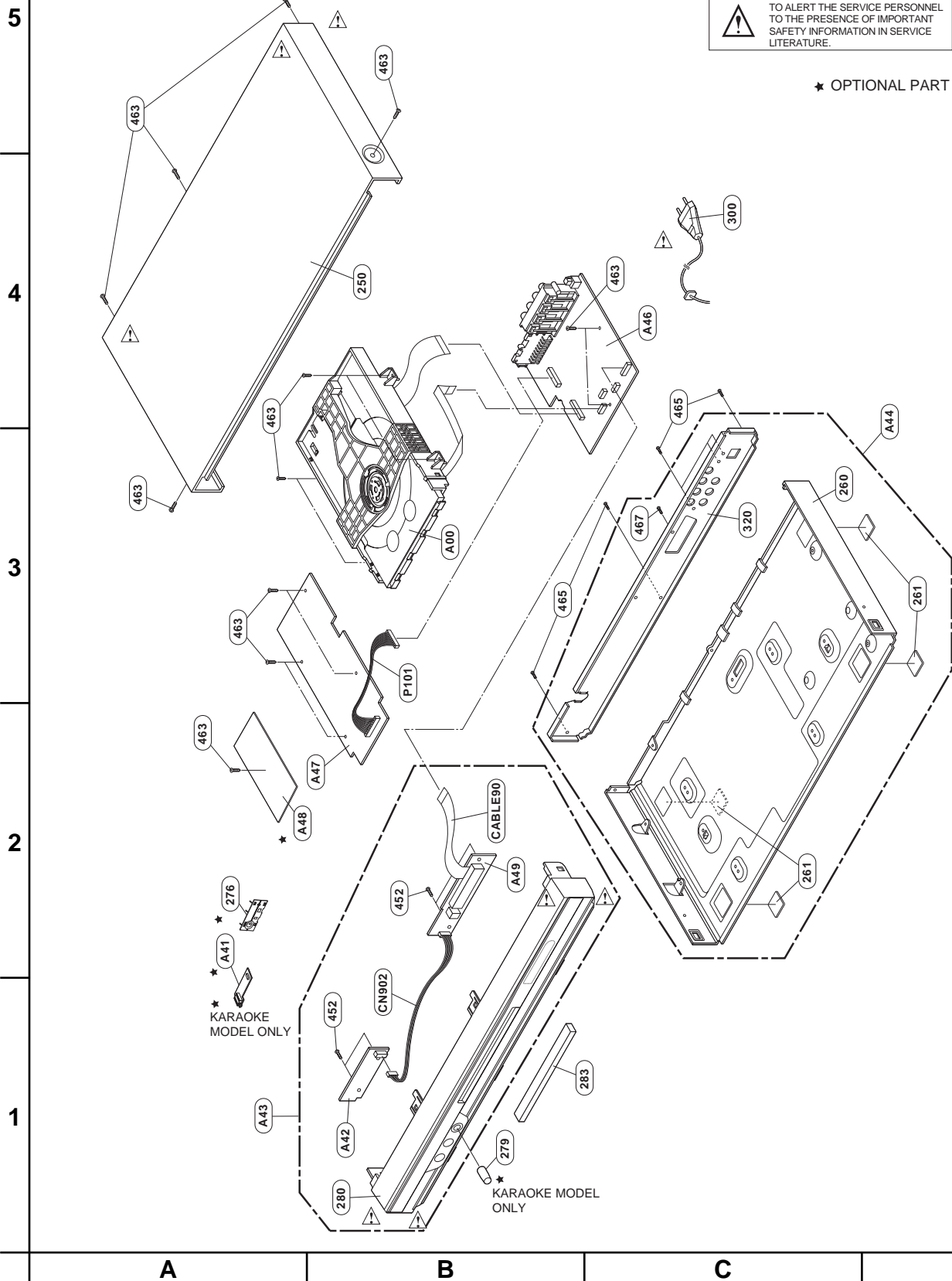

2. Deck Mechanism Section(DP-10)

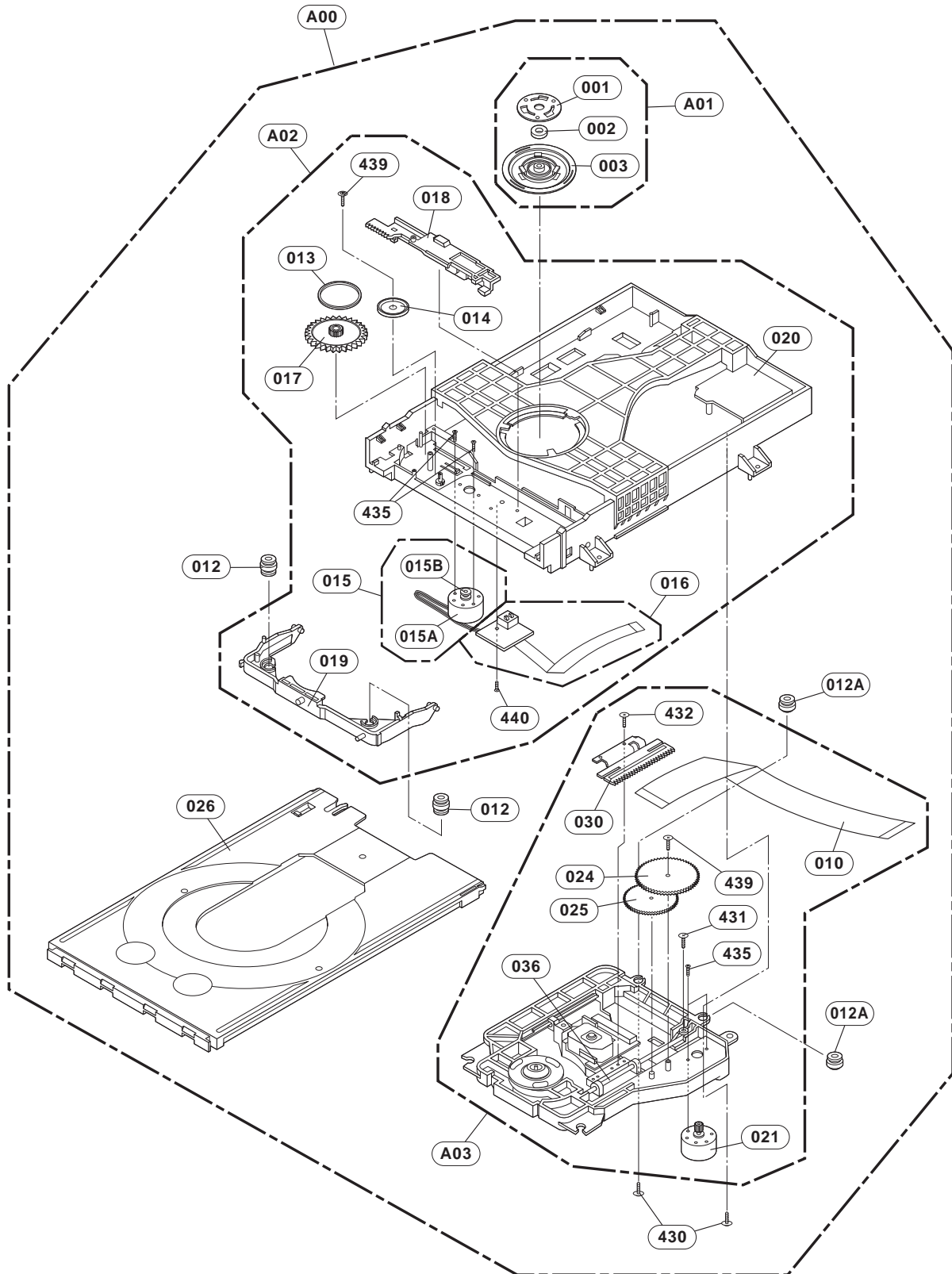

3. Packing Accessory Section

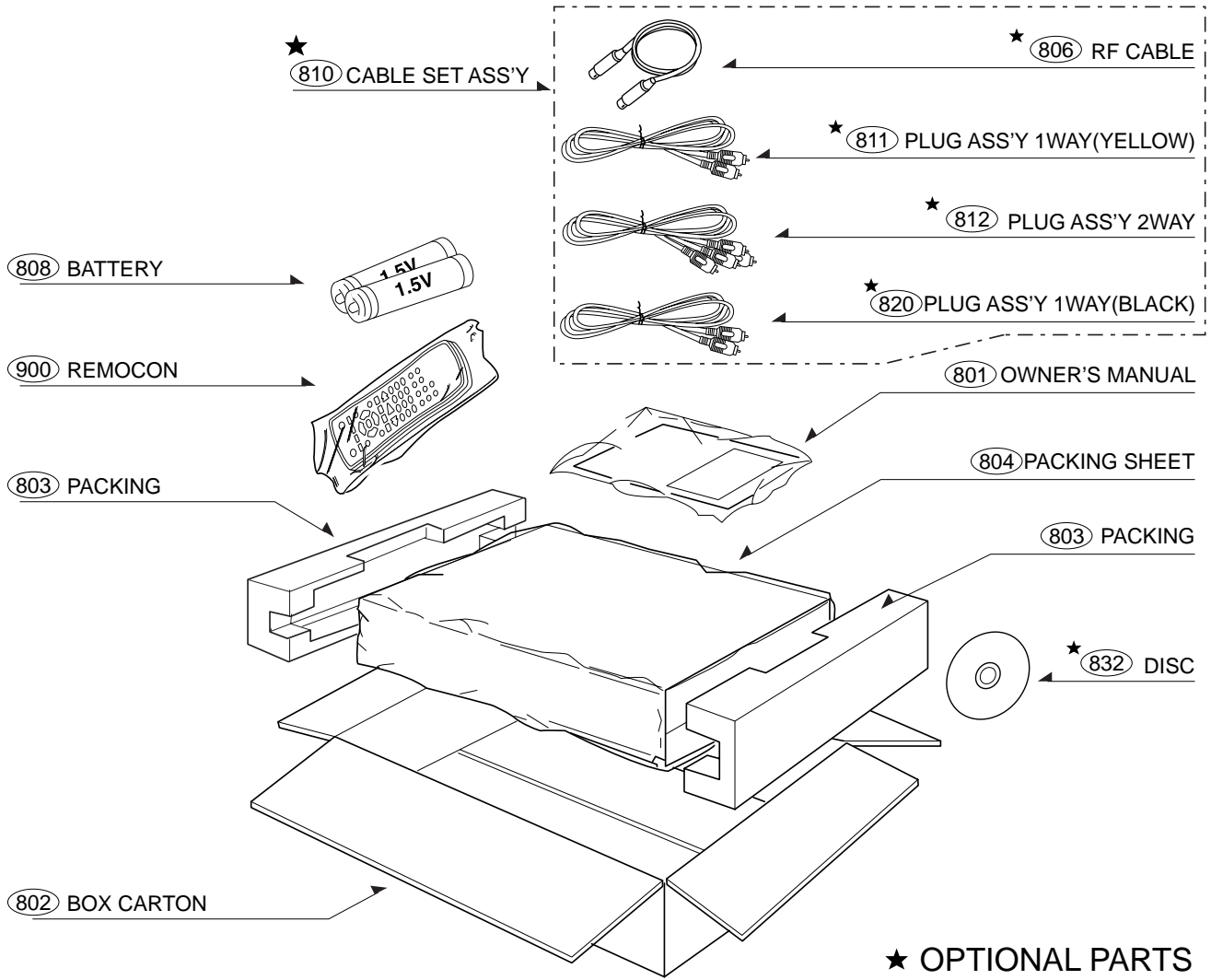

SECTION 3 ELECTRICAL CONTENTS

ELECTRICAL TROUBLESHOOTING GUIDE.....	3-2
1. Power check flow.....	3-2
2. System operation flow	3-3
3. Test & debug flow	3-4
4. KARAOKE Flow (KARAOKE MODEL ONLY).....	3-10
DETAILS AND WAVEFORMS ON SYSTEM TEST AND DEBUGGING	3-11
1. SYSTEM 27MHz CLOCK, RESET, FLASH R/W SIGNAL	3-11
2. SDRAM CLOCK.....	3-13
3. TRAY OPEN/CLOSE SIGNAL	3-13
4. SLED CONTROL RELATED SIGNAL(NO DISC CONDITION)	3-14
5. LENS CONTROL RELATED SIGNAL(NO DISC CONDITION)	3-14
6. LASER POWER CONTROL RELATED SIGNAL(NO DISC CONDITION).....	3-15
7. DISC TYPE JUDGEMENT WAVEFORM	3-15
8. FOCUS ON WAVEFORM.....	3-17
9. SPINDLE CONTROL WAVEFORM(NO DISC CONDITION	3-18
10. TRACKING CONTROL RELATED SIGNAL(System checking).....	3-19
11. MT1389E AUDIO OPTICAL AND COAXIAL OUTPUT (SPDIF)	3-20
12. MT1389E VIDEO OUTPUT WAVEFORM	3-20
13. AUDIO OUTPUT FROM AUDIO MT1389E.....	3-21
BLOCK DIAGRAMS	3-22
1. OVERALL BLOCK DIAGRAM.....	3-22
2. POWER(SMPS) BLOCK DIAGRAM.....	3-23
3. SERVO BLOCK DIAGRAM	3-24
4. MPEG & MEMORY BLOCK DIAGRAM	3-25
5. VIDEO & AUDIO BLOCK DIAGRAM	3-26
CIRCUIT DIAGRAMS	3-27
1. POWER(SMPS) CIRCUIT DIAGRAM.....	3-27
2. SYSTEM CIRCUIT DIAGRAM	3-29
3. SERVO CIRCUIT DIAGRAM	3-31
4. AV/JACKCIRCUIT DIAGRAM.....	3-33
5. TIMER CIRCUIT DIAGRAM (3 TOOL ONLY)	3-35
6. TIMER CIRCUIT DIAGRAM (4 TOOL ONLY)	3-37
7. TIMER CIRCUIT DIAGRAM (6 TOOL ONLY)	3-39
8. TIMER CIRCUIT DIAGRAM (7 TOOL ONLY)	3-41
9. TIMER CIRCUIT DIAGRAM (8 TOOL ONLY)	3-43
10. KARAOKE CIRCUIT DIAGRAM (KARAOKE MODEL ONLY)	3-45
• CIRCUIT VOLTAGE CHART	3-47
PRINTED CIRCUIT DIAGRAMS	3-49
1. MAIN P.C.BOARD	3-49
2. KEY P.C.BOARD.....	3-51
3. TIMER P.C.BOARD	3-51
4. SMPS P.C.BOARD (360mm ONLY)	3-53
5. SMPS P.C.BOARD (430mm ONLY)	3-53
6. JACK P.C.BOARD (OPTIONAL PART).....	3-53
7. KARAOKE P.C.BOARD (KARAOKE MODEL ONLY)	3-54

ELECTRICAL TROUBLESHOOTING GUIDE

1. Power check flow

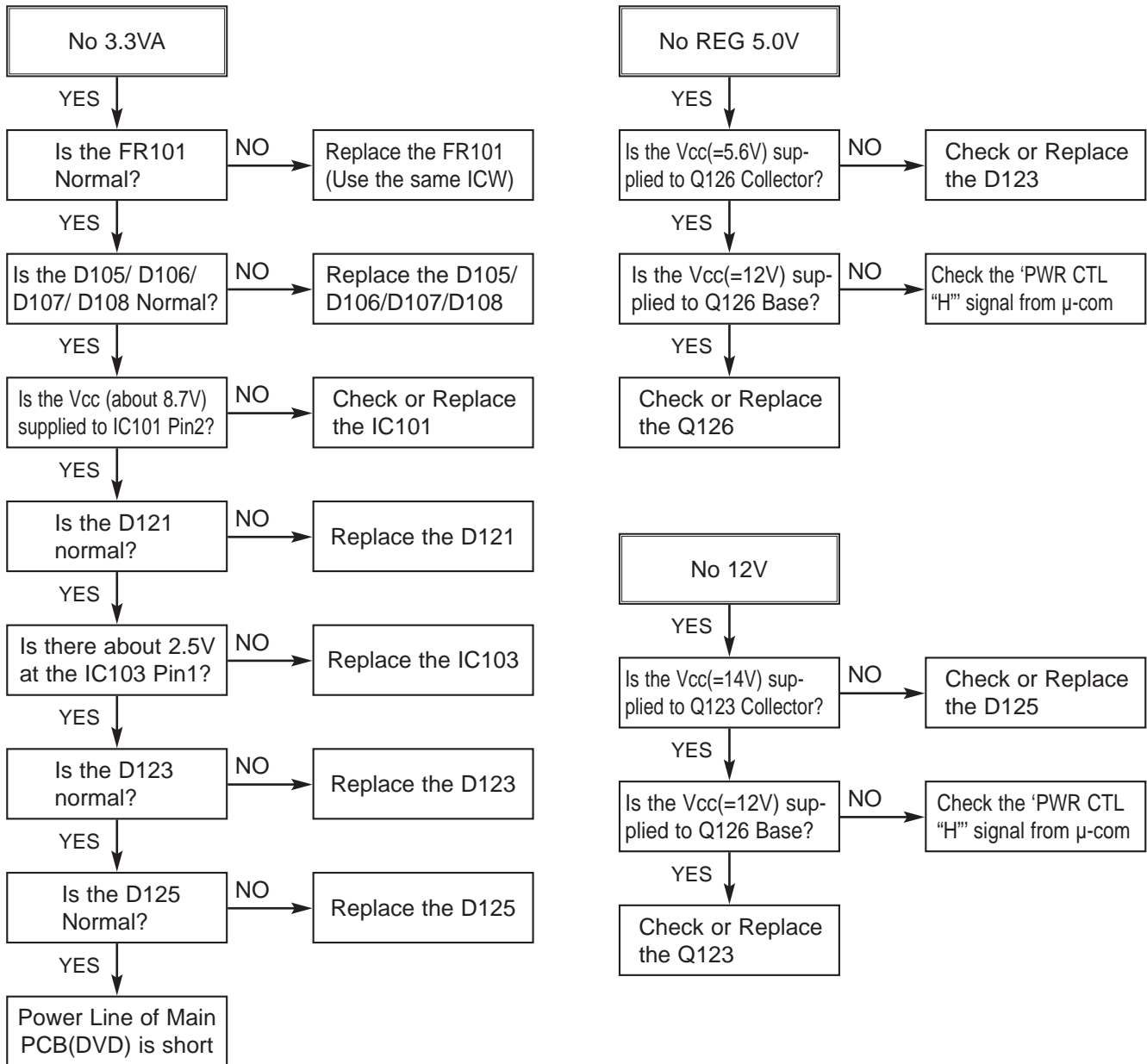

2. System operation flow

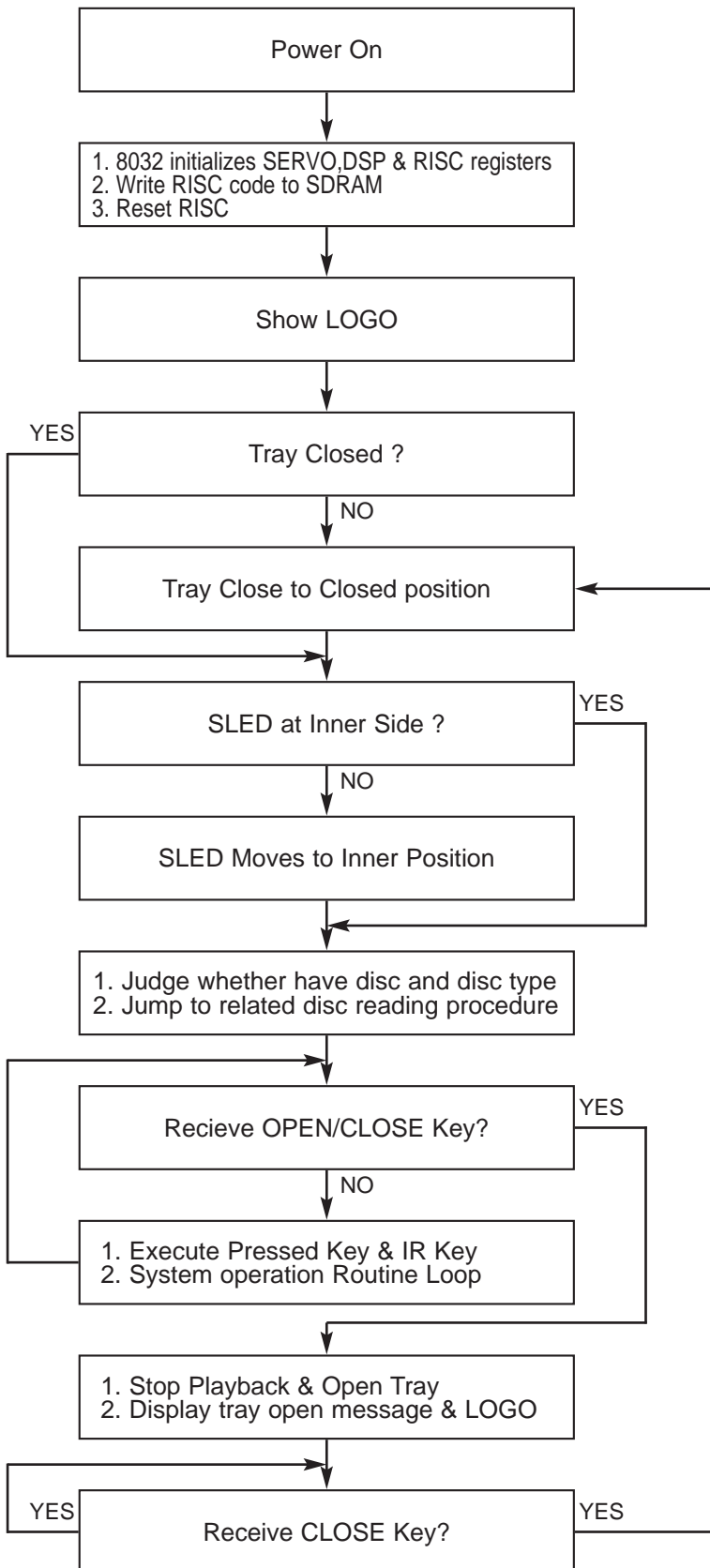

3. Test & debug flow

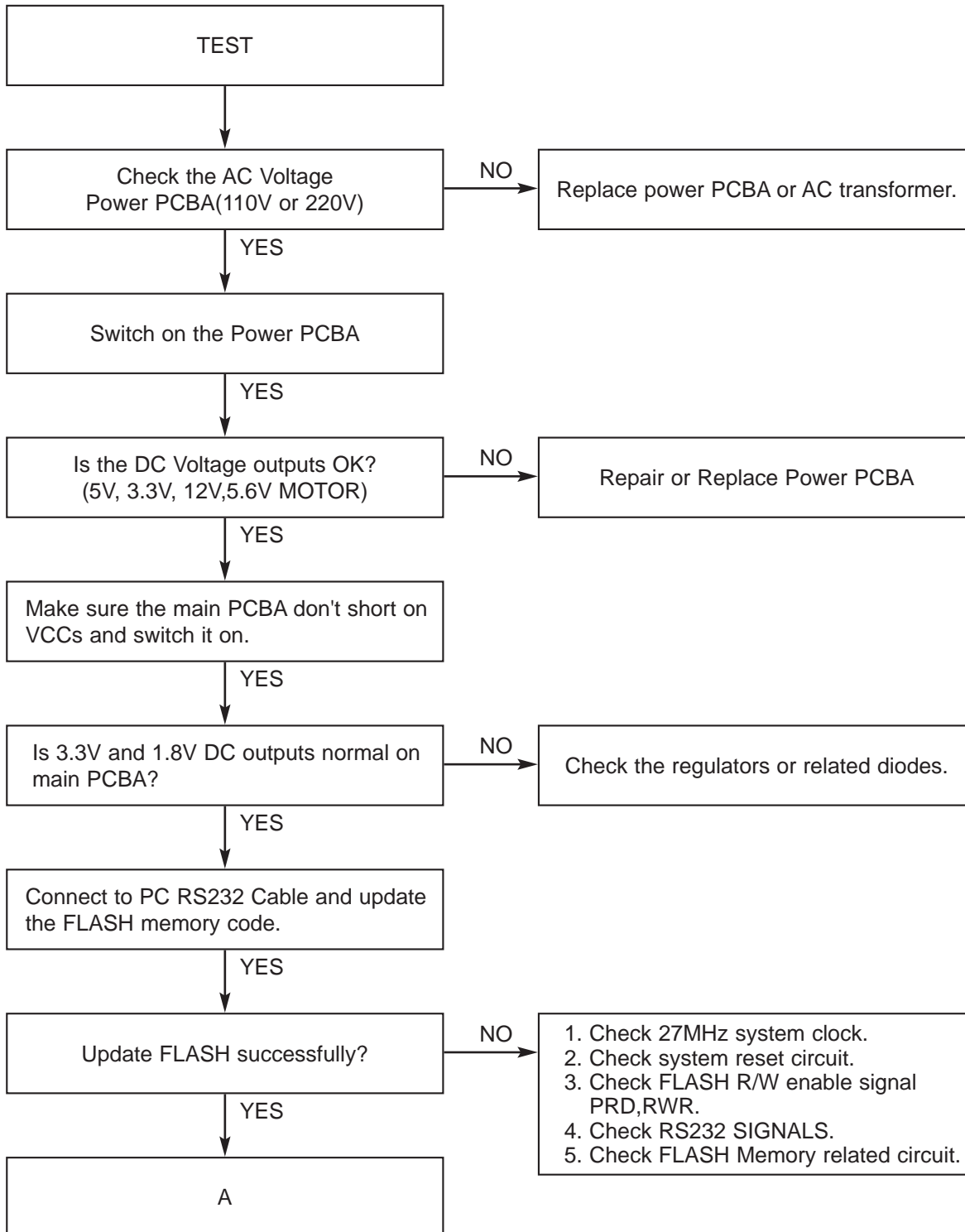

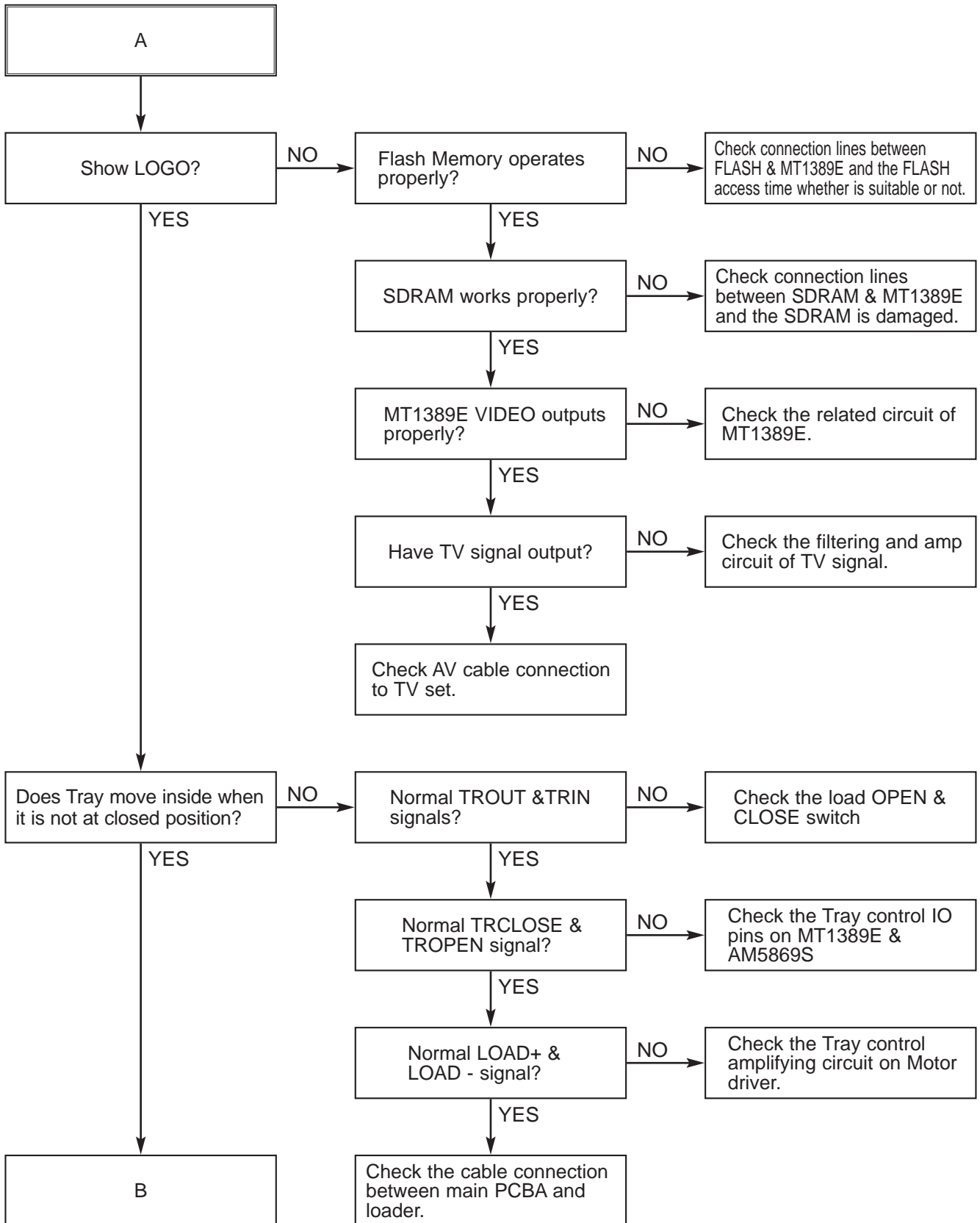

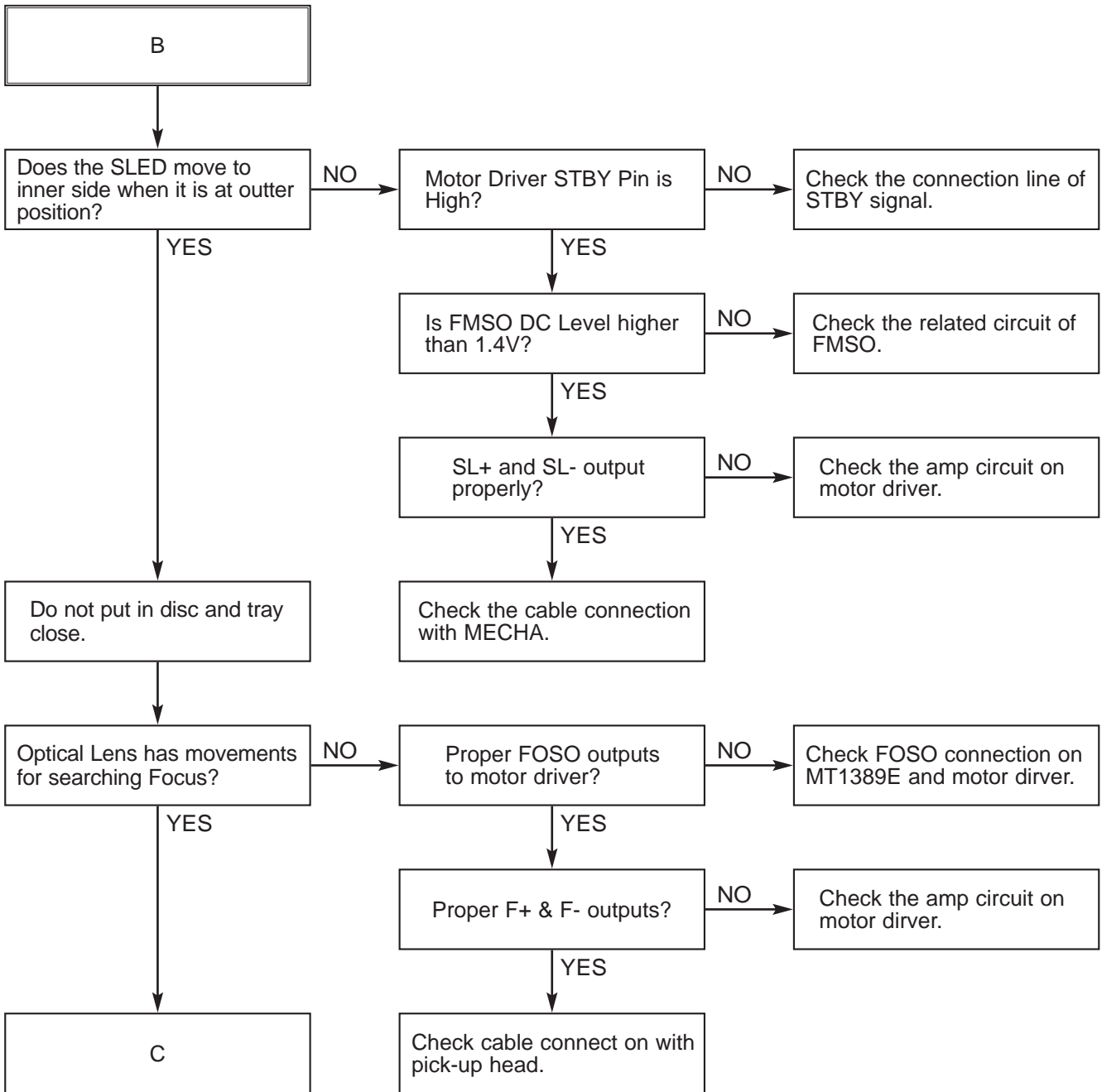

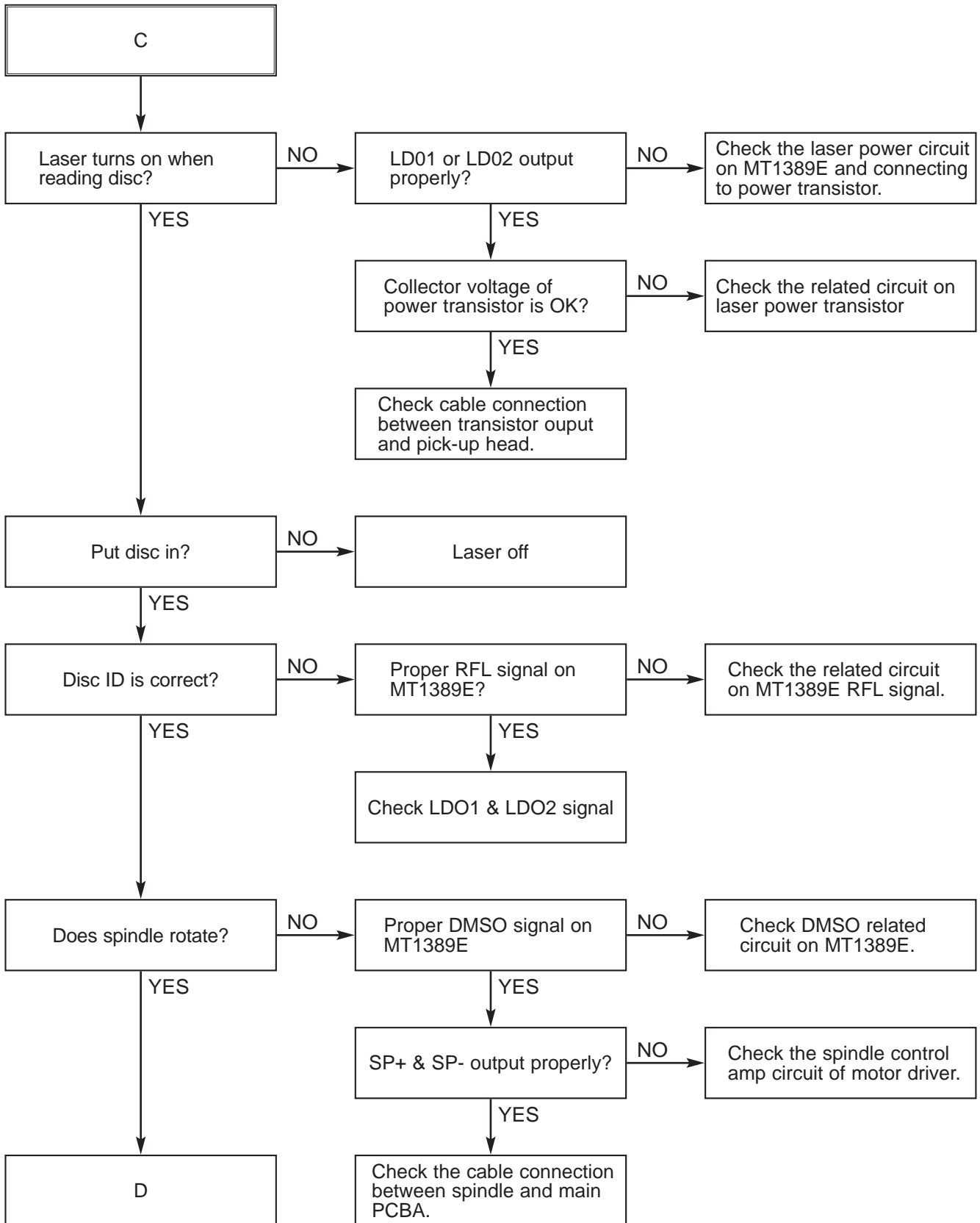

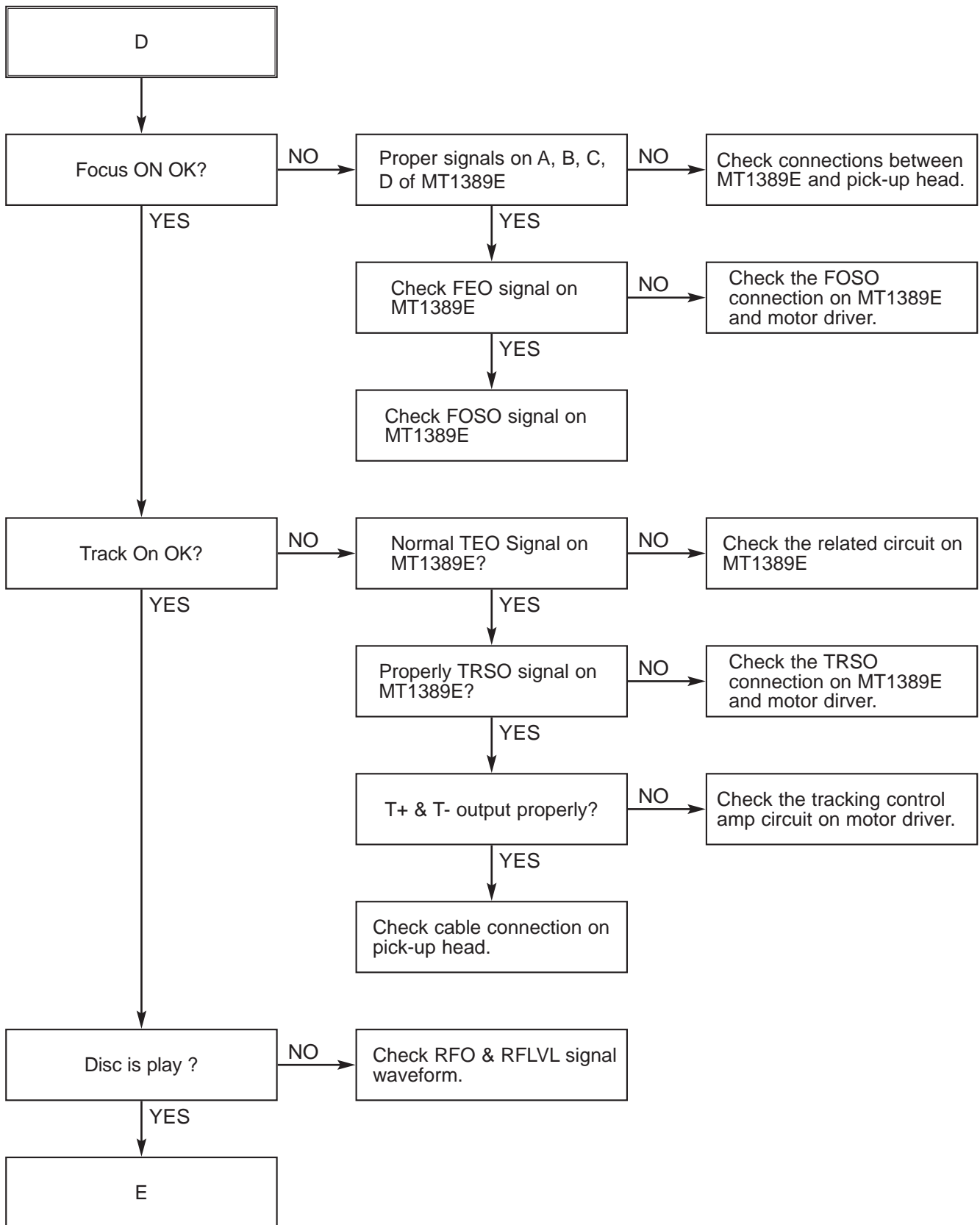

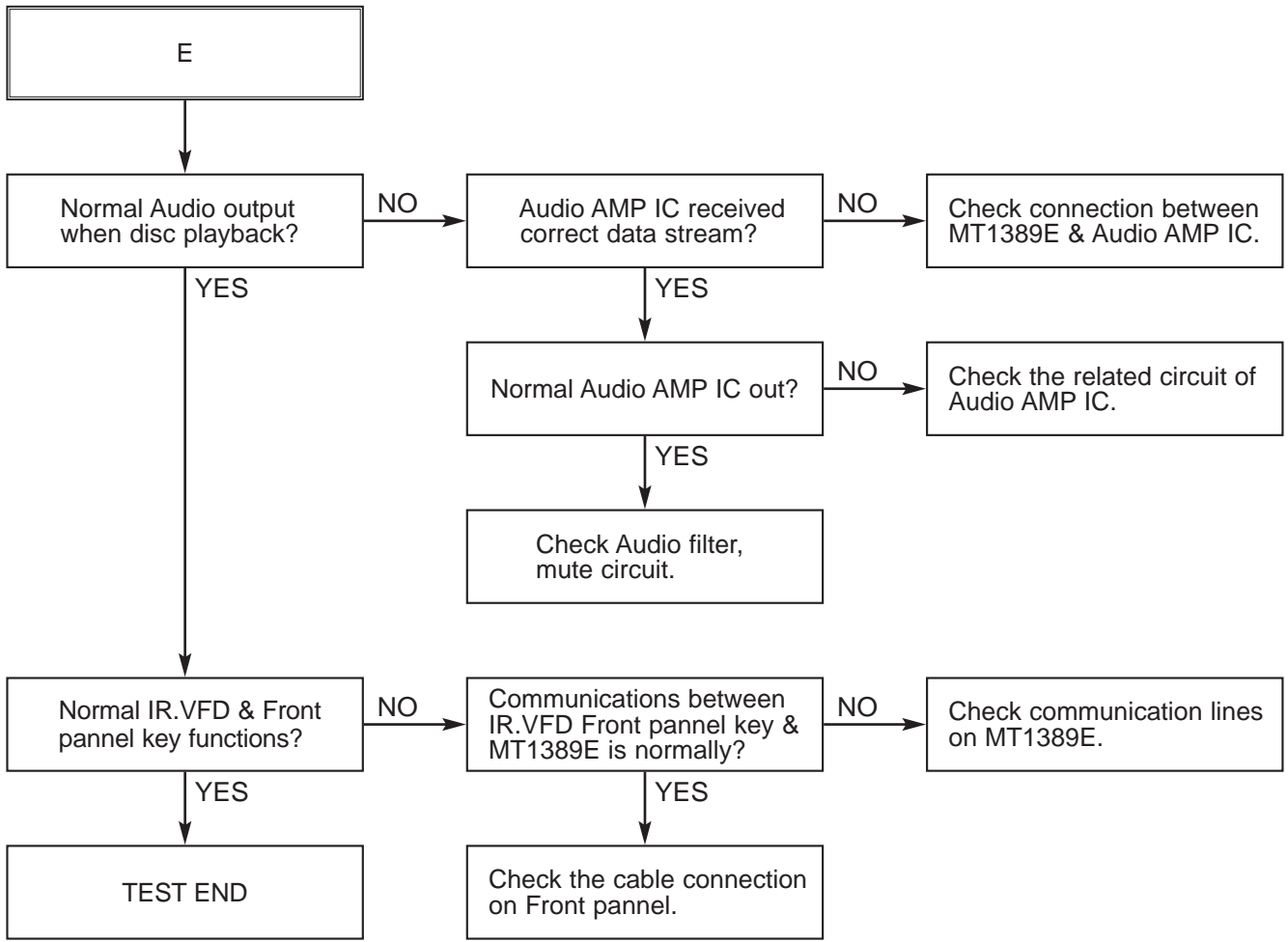

4. KARAOKE Flow (KARAOKE MODEL ONLY)

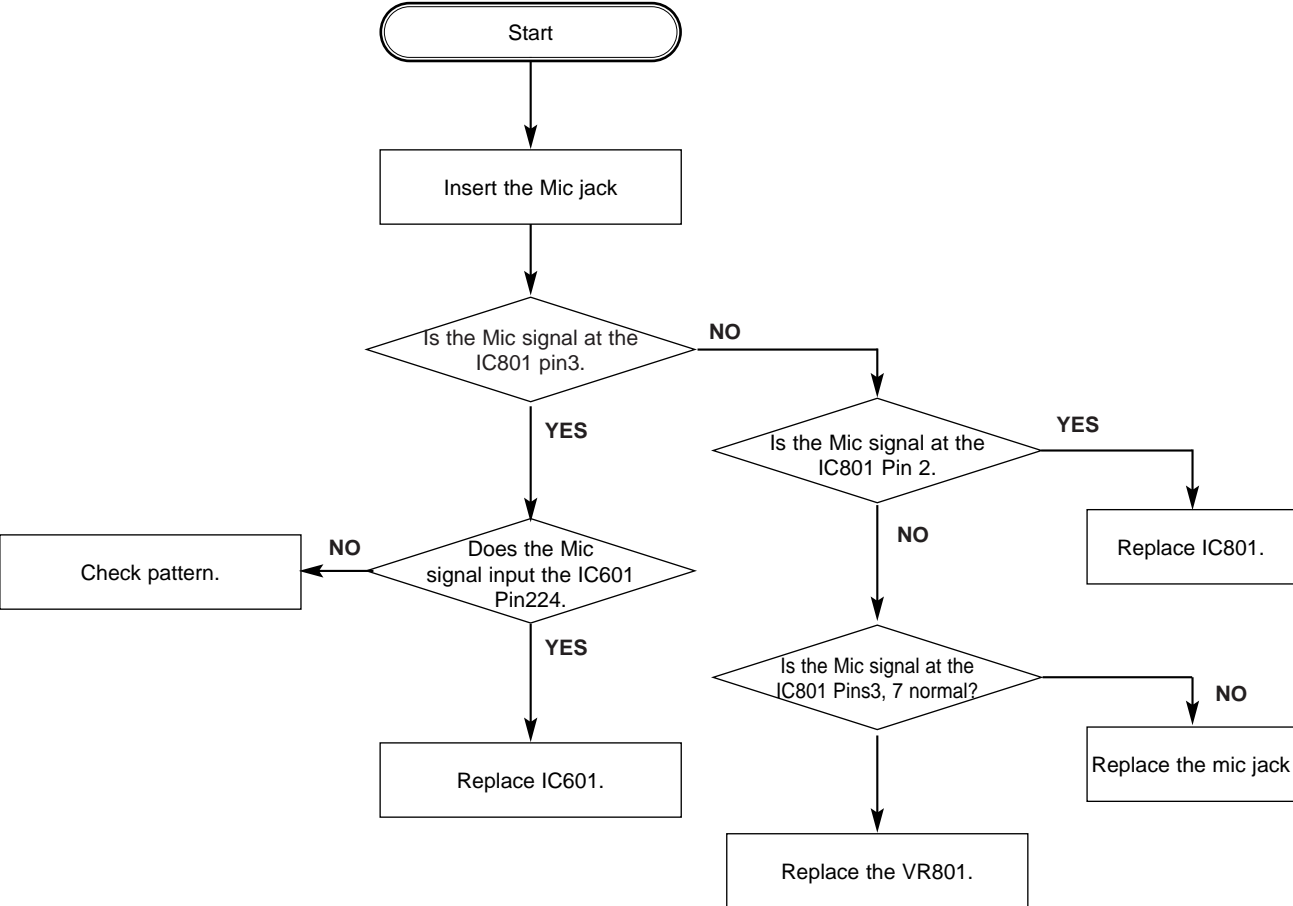

DETAILS AND WAVEFORMS ON SYSTEM TEST AND DEBUGGING

1. SYSTEM 27MHz CLOCK, RESET, FLASH R/W SIGNAL.

1) MT1389E main clock is at 27MHz(X601)

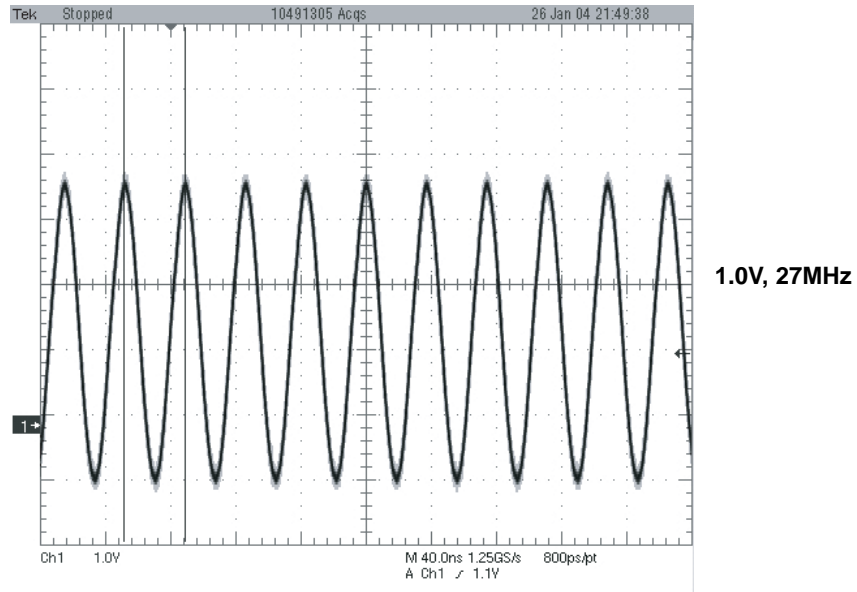

FIG 1-1

2) MT1389 reset is low active.

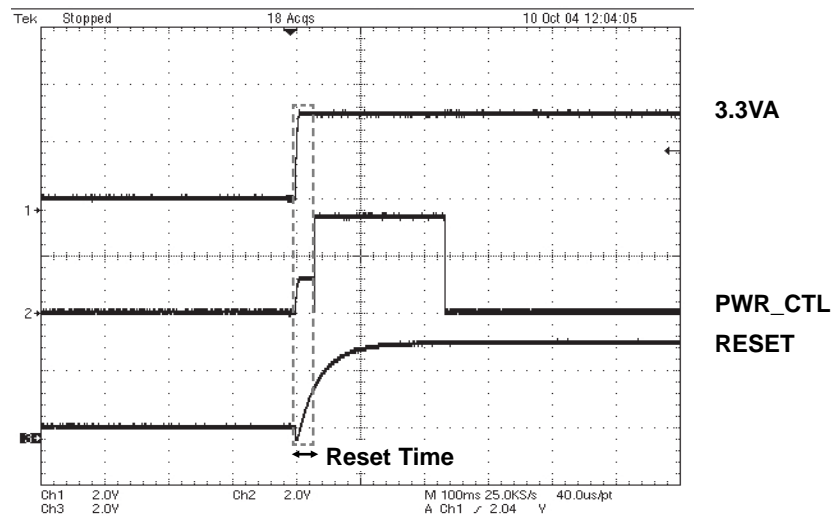

FIG 1-2

3) RS232 waveform during procedure(Downloading)

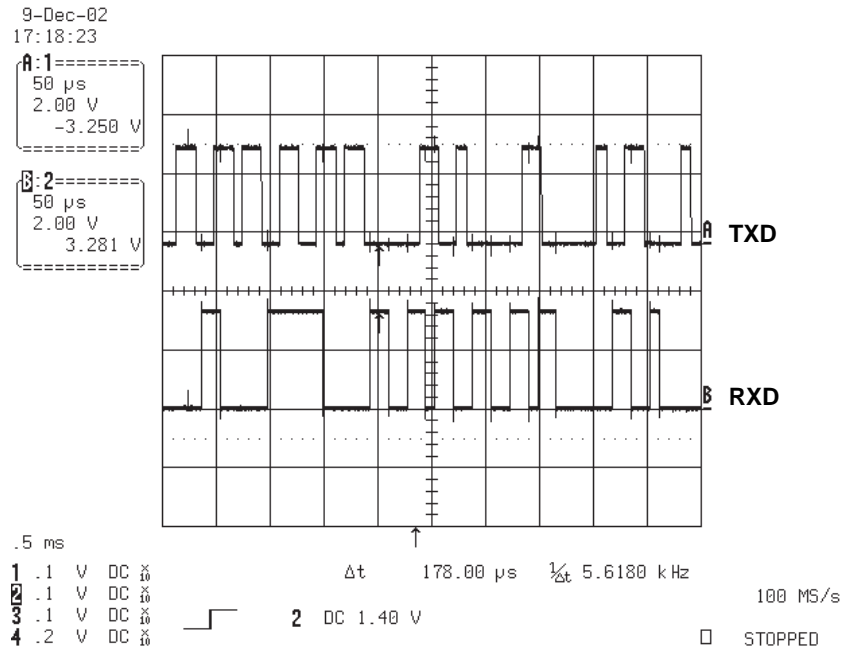

FIG 1-3

4) Flash R/W enable signal during download(Downloading)

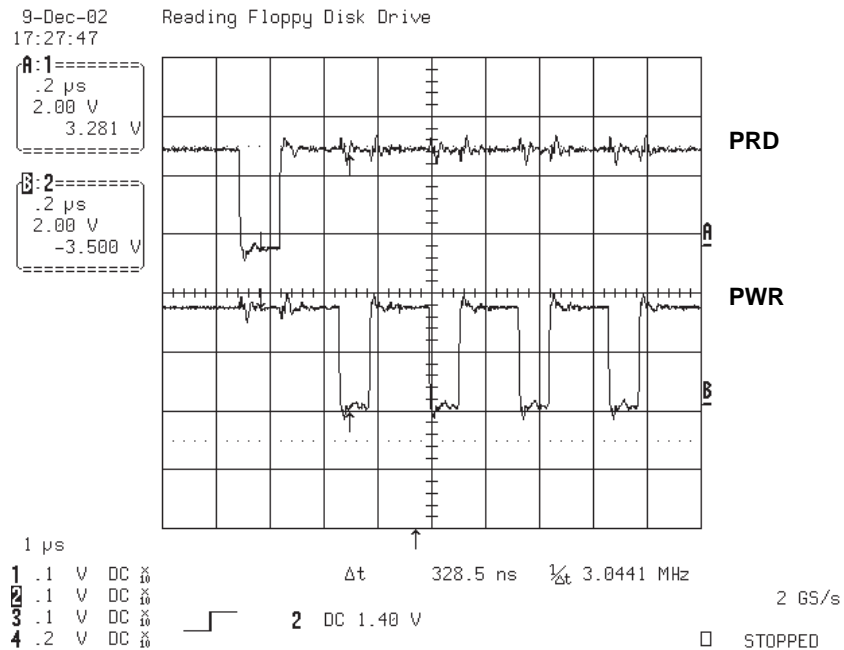

FIG 1-4

2. SDRAM CLOCK

DCLK = 128MHz, Vp-p=2.2, Vmax=2.7V

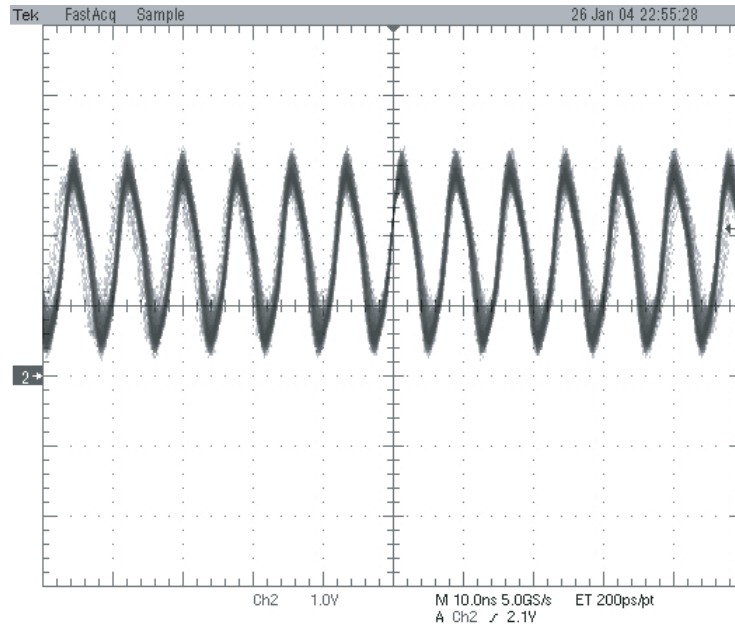

FIG 2-1

3. TRAY OPEN/CLOSE SIGNAL

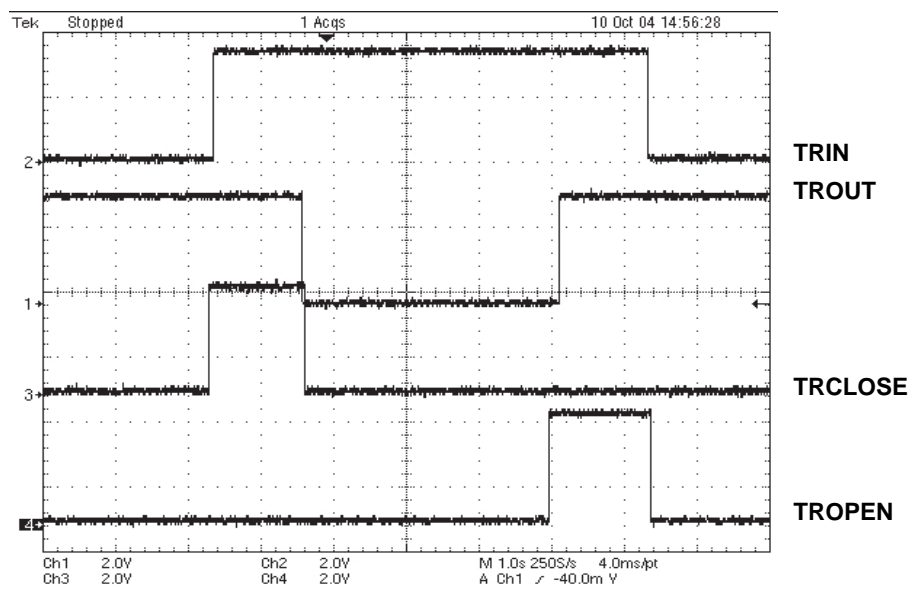

FIG 3-1

4. SLED CONTROL RELATED SIGNAL (NO DISC CONDITION)

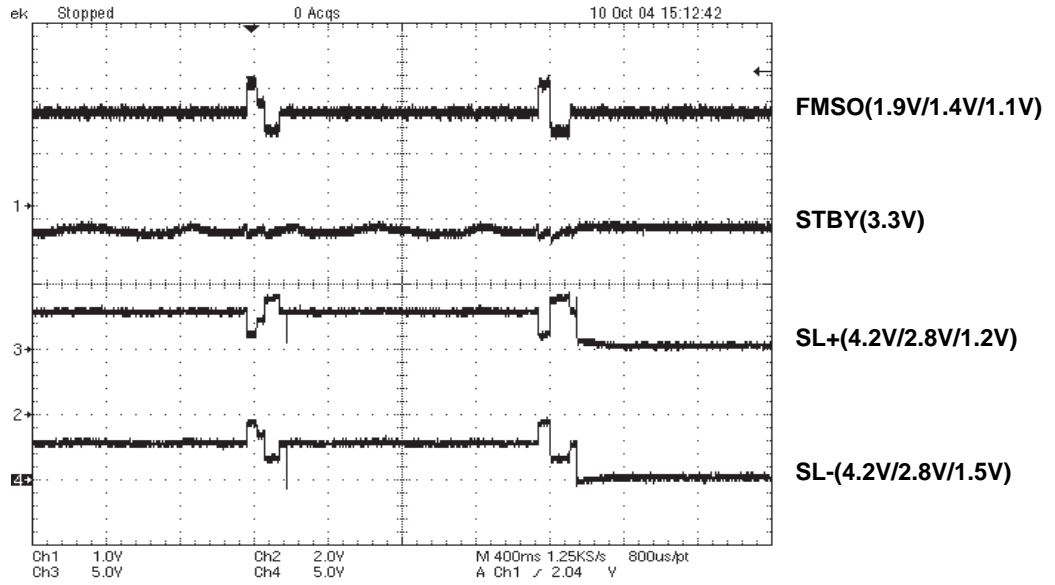

FIG 4-1

5. LENS CONTROL RELATED SIGNAL(NO DISC CONDITION)

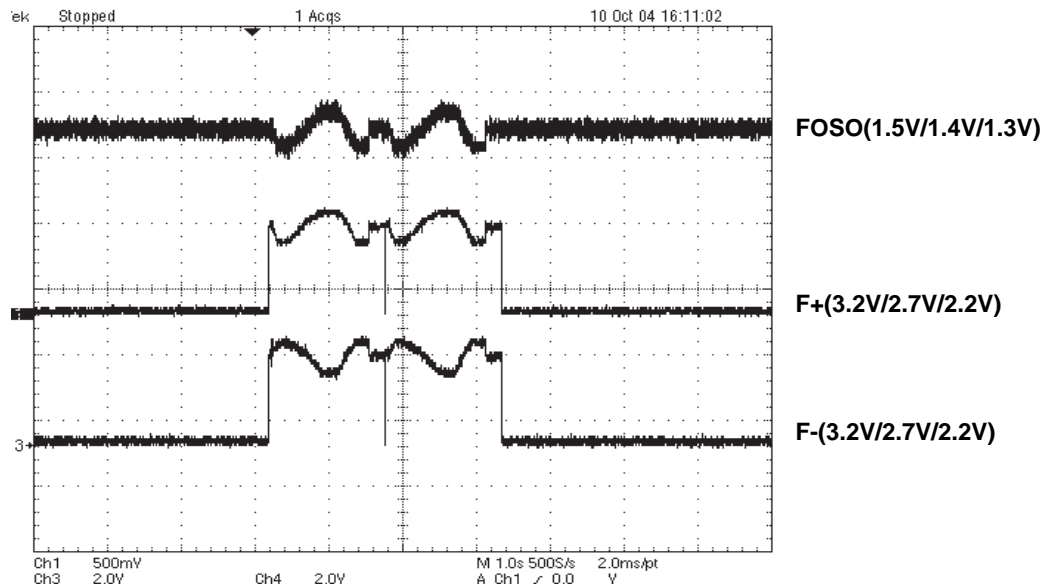

FIG 5-1

6. LASER POWER CONTROL RELATED SIGNAL(NO DISC CONDITION)

DCLK = 128MHz, Vp-p=2.2, Vmax=2.7V

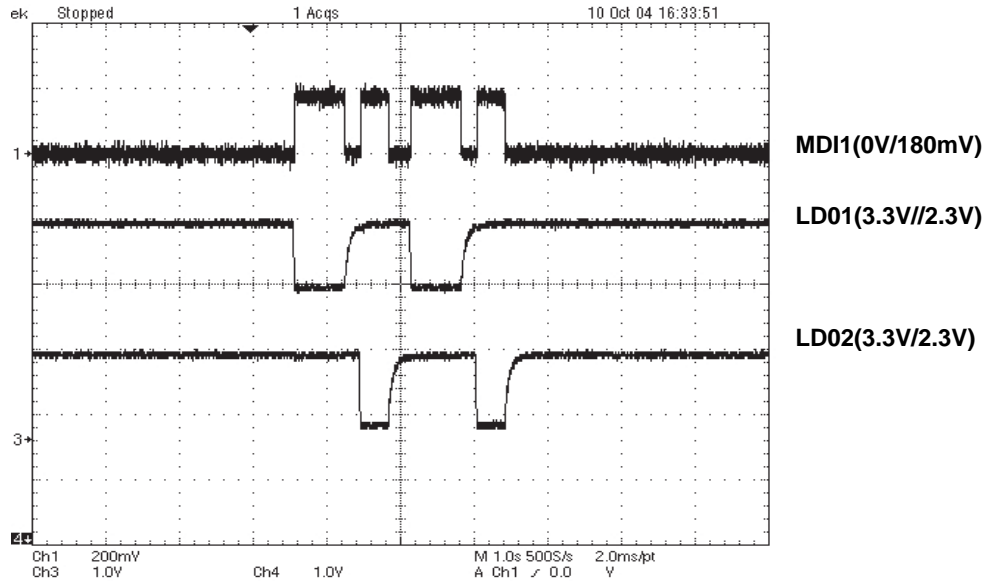

FIG 7-2 (DVD)

7. DISC TYPE JUDGEMENT WAVEFORM

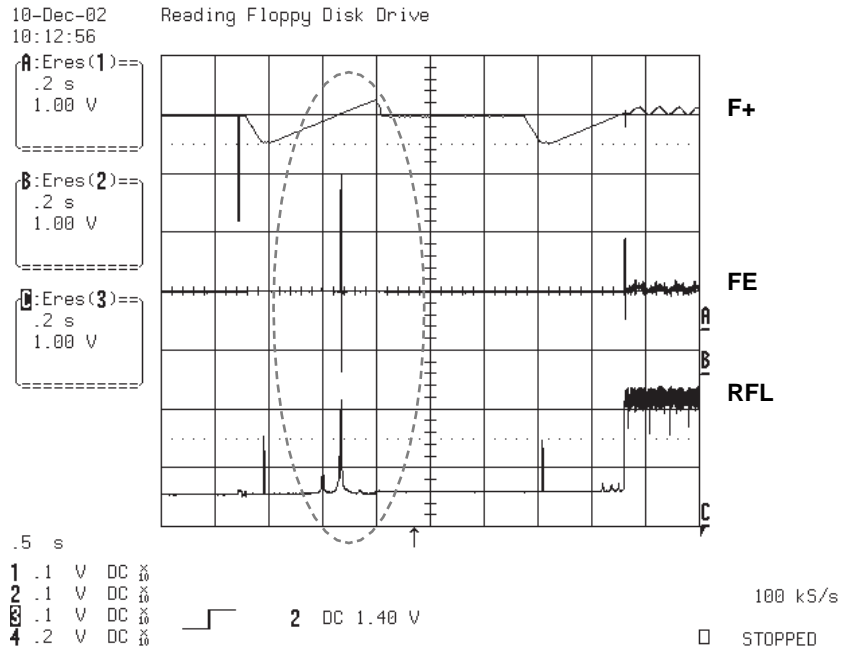

FIG 7-1

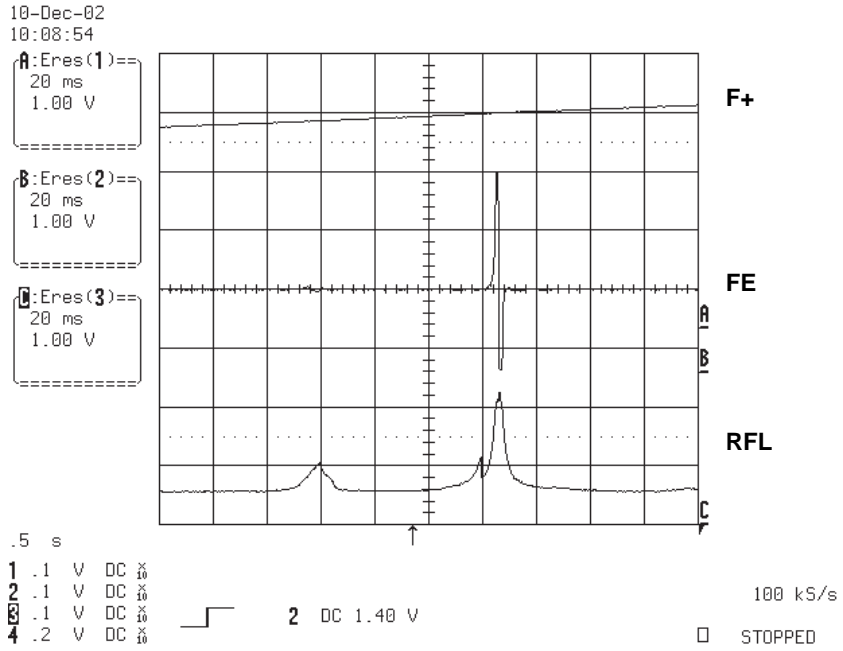

FIG 7-2 (DVD)

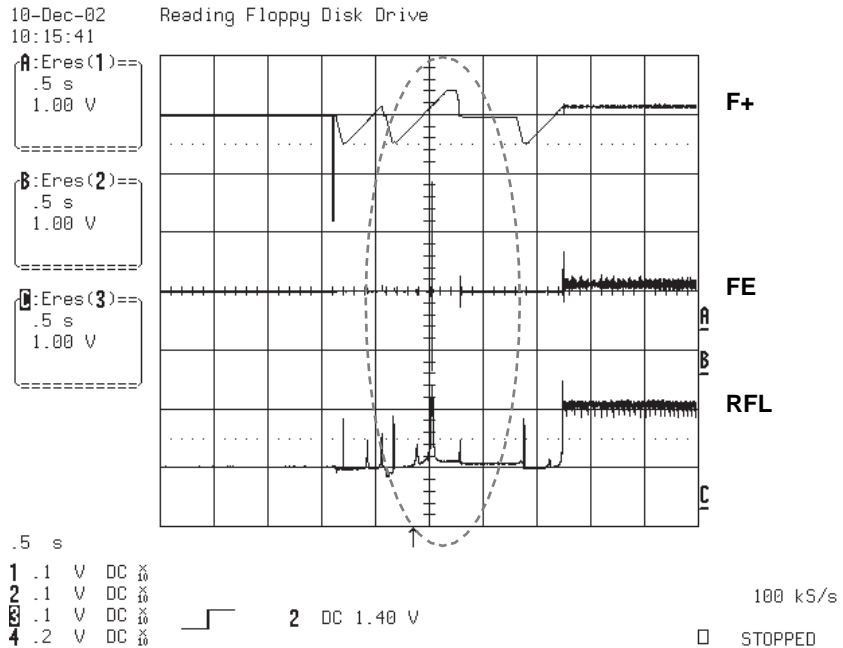

FIG 7-3 (CD)

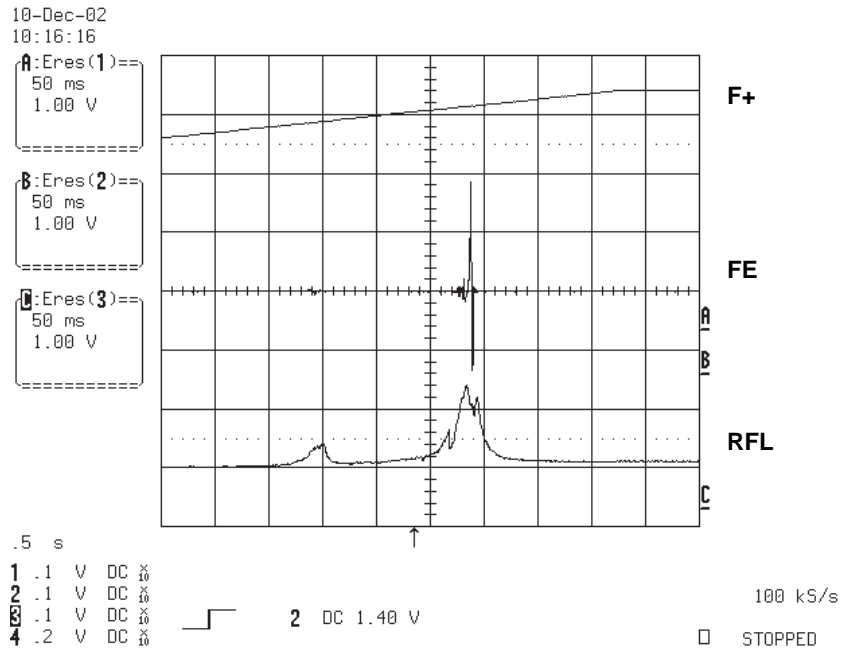

FIG 7-4 (CD)

8. FOCUS ON WAVEFORM

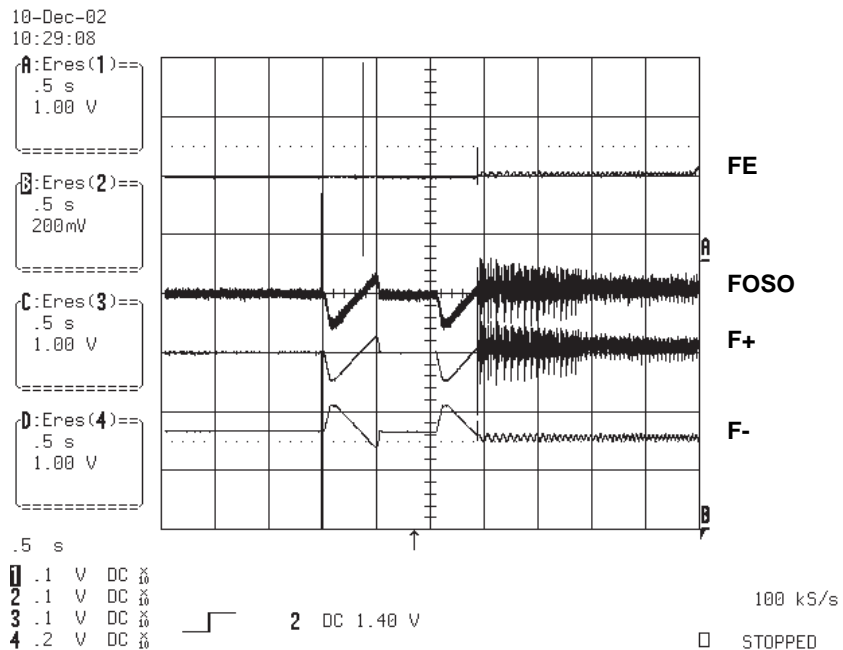

FIG 8-1 (DVD)

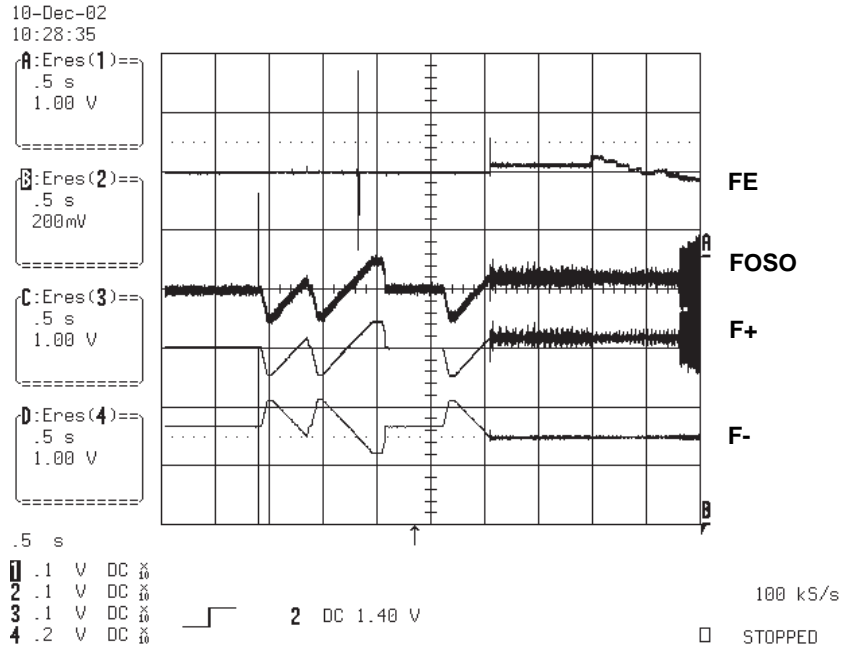

FIG 8-2 (CD)

9) SPINDLE CONTROL WAVEFORM (NO DISC CONDITION)

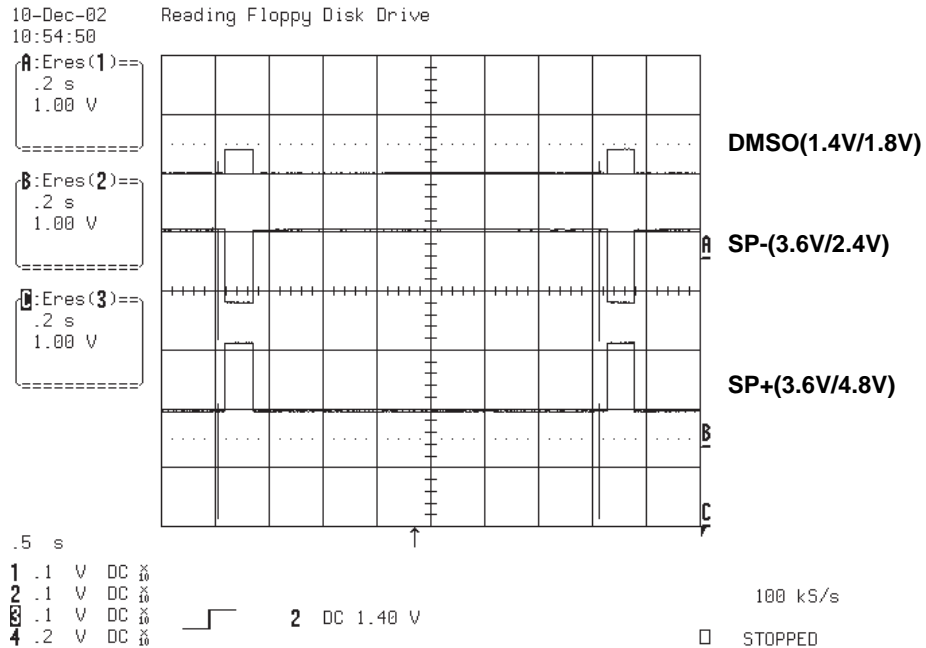

FIG 9-1

10. TRACKING CONTROL RELATED SIGNAL(System checking)

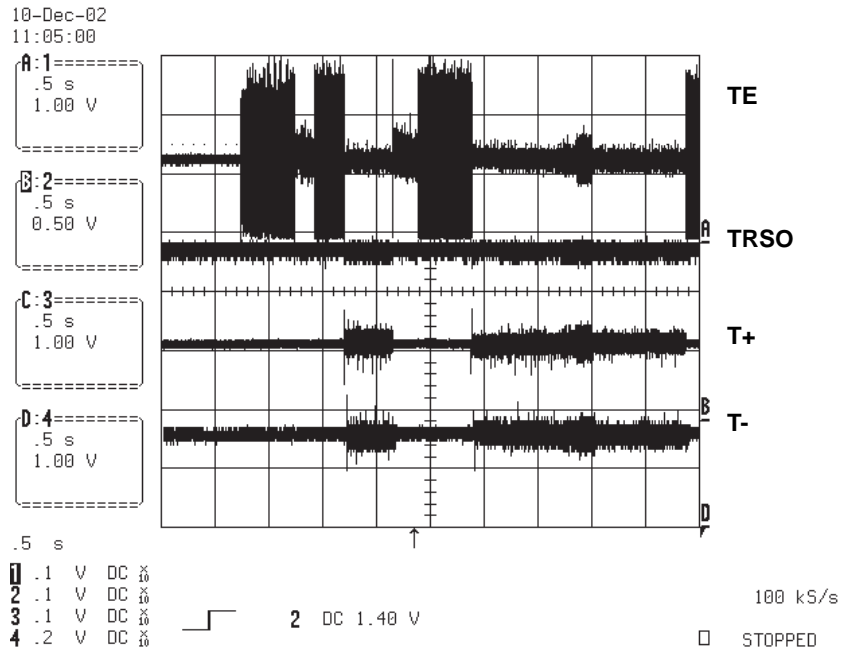

FIG 10-1 (DVD)

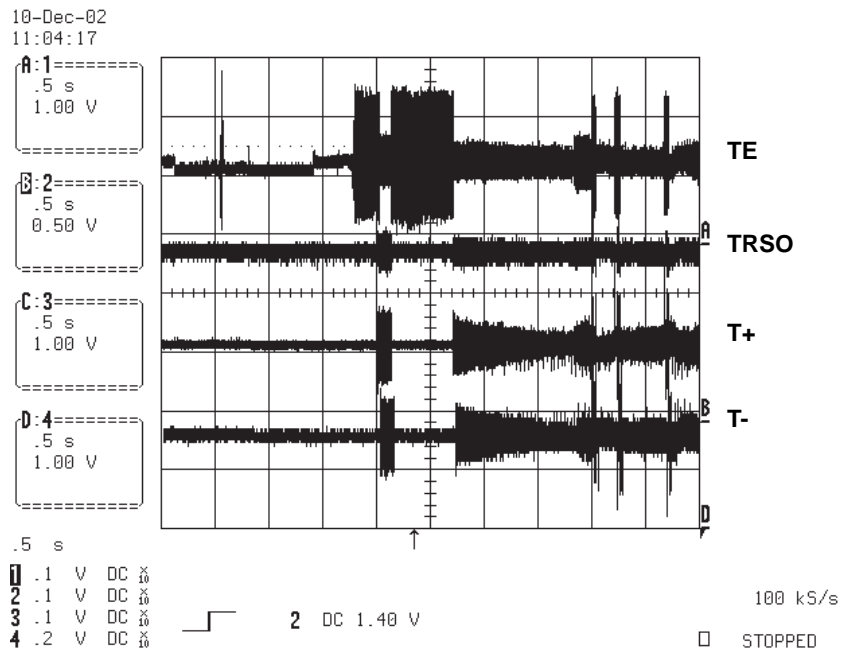

FIG 10-2 (CD)

11. MT1389E AUDIO OPTICAL AND COAXIAL OUTPUT (SPDIF)

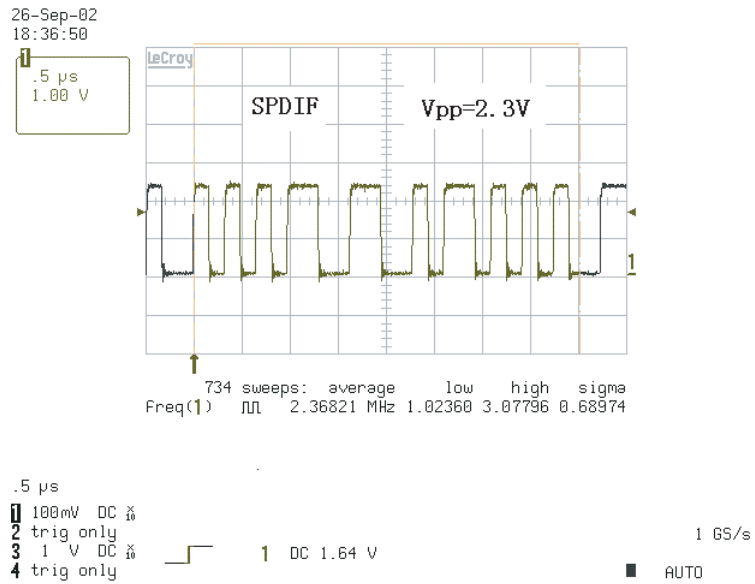

FIG 11-1

12. MT1389E VIDEO OUTPUT WAVEFORM

1) 100%

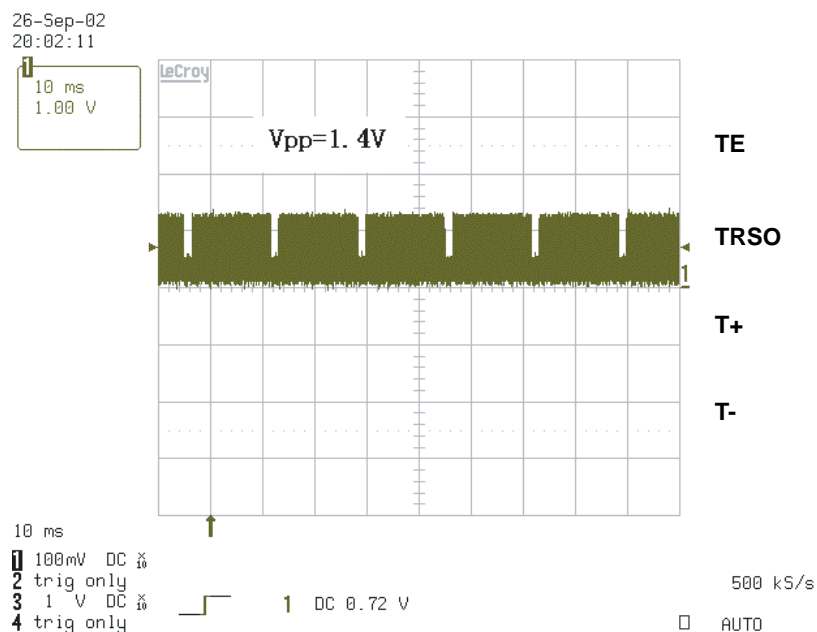

FIG 12-1

2) COMPOSITE VIDEO SIGNAL

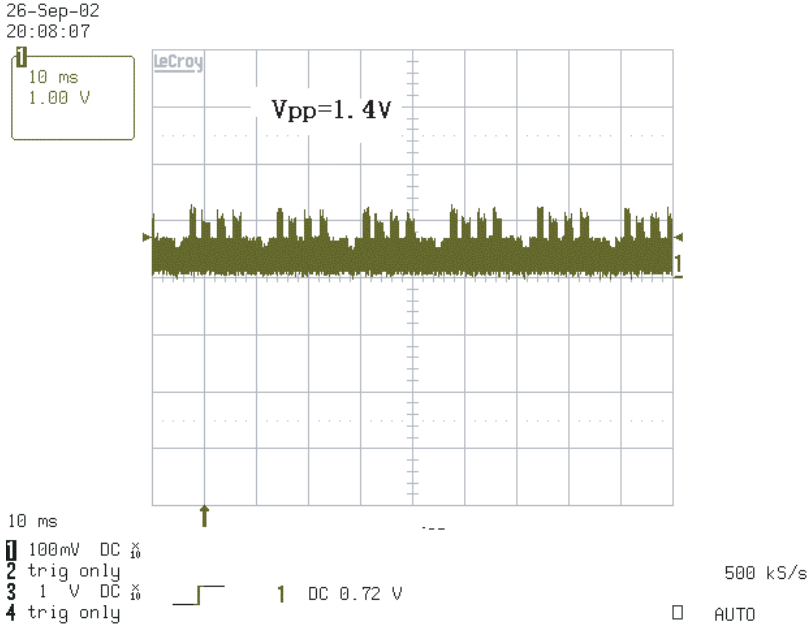

FIG 12-2

13. AUDIO OUTPUT FROM AUDIO MT1389E

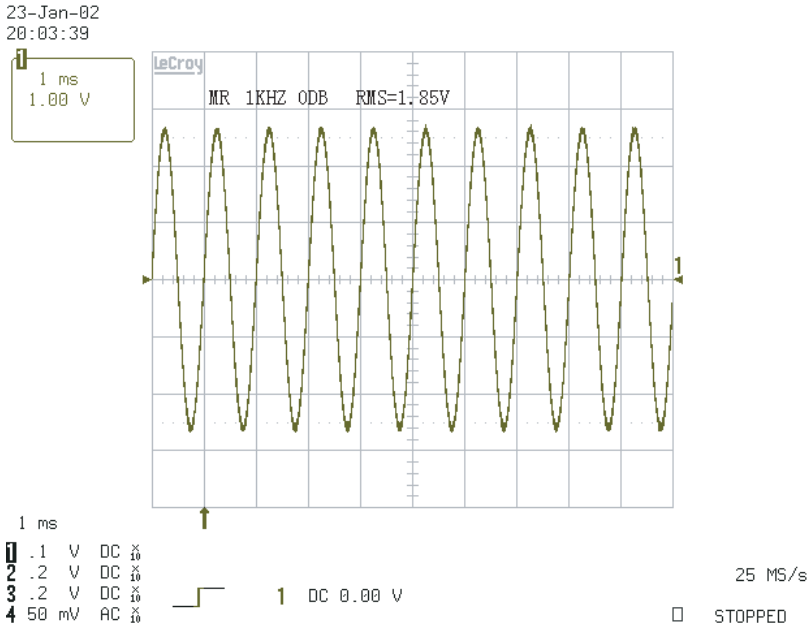
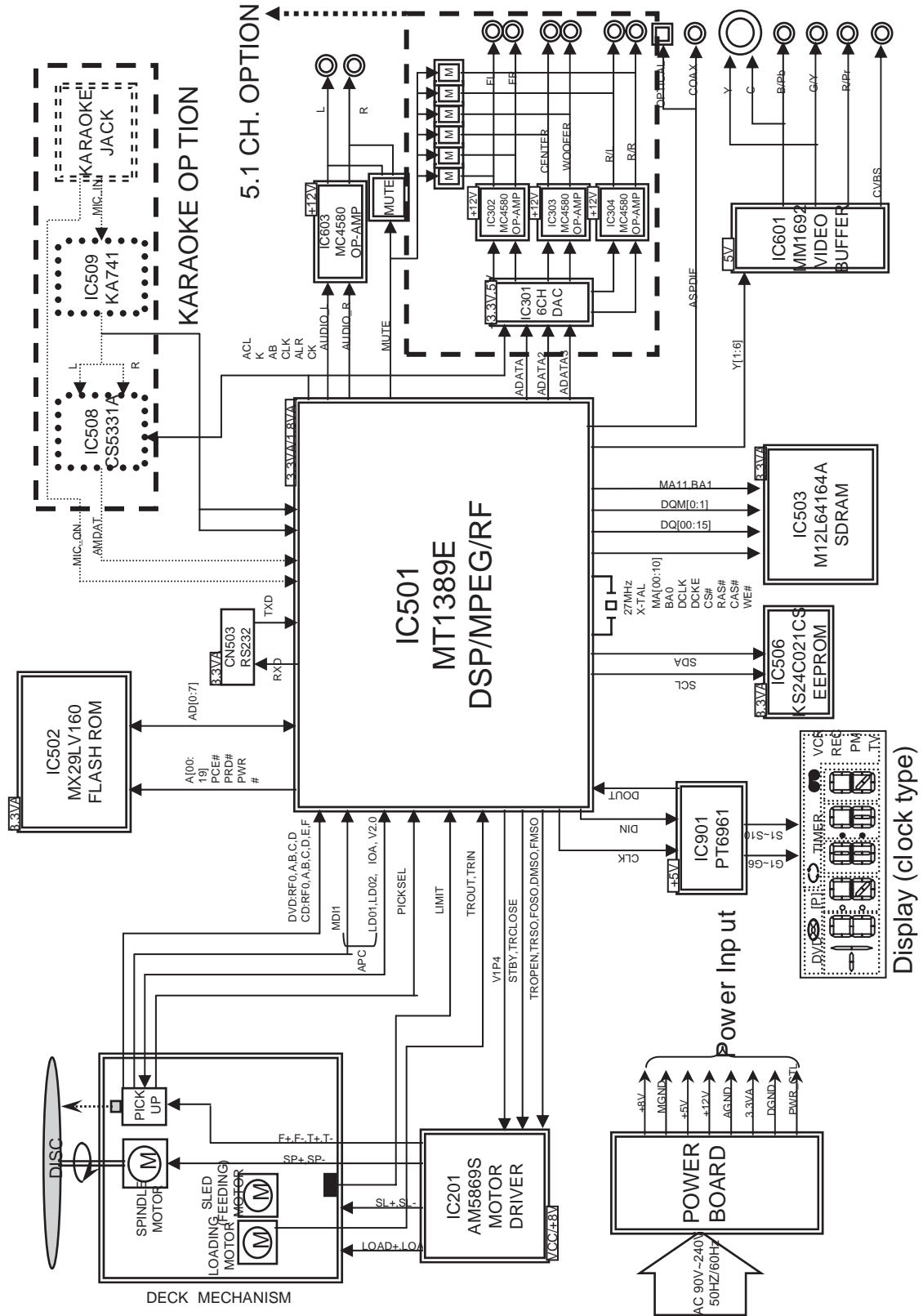

FIG 13-1

BLOCK DIAGRAMS

1. OVERALL BLOCK DIAGRAM



MT1389E

2. POWER(SMPS) BLOCK DIAGRAM

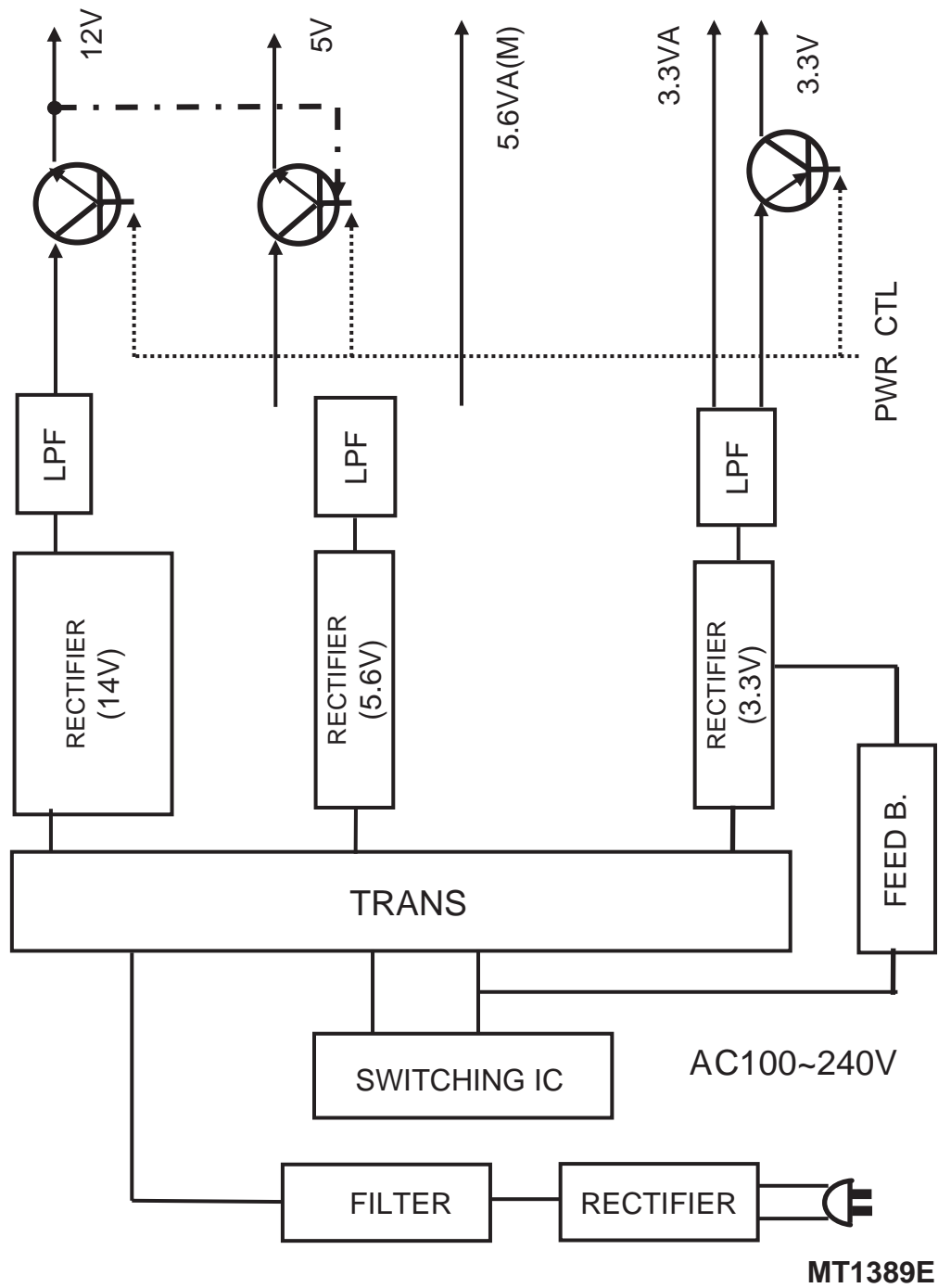

3. SERVO BLOCK DIAGRAM

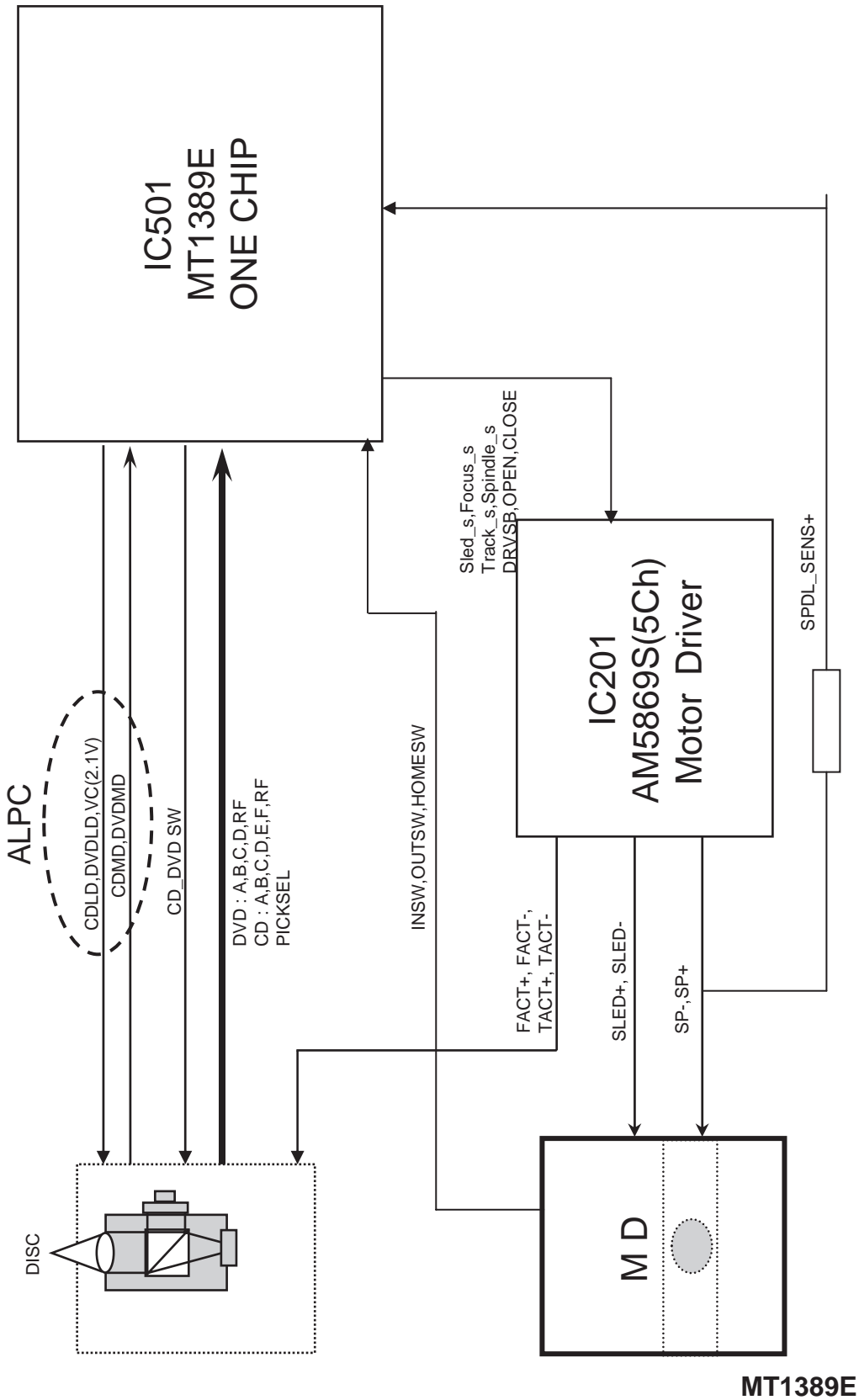

4. MPEG & MEMORY BLOCK DIAGRAM

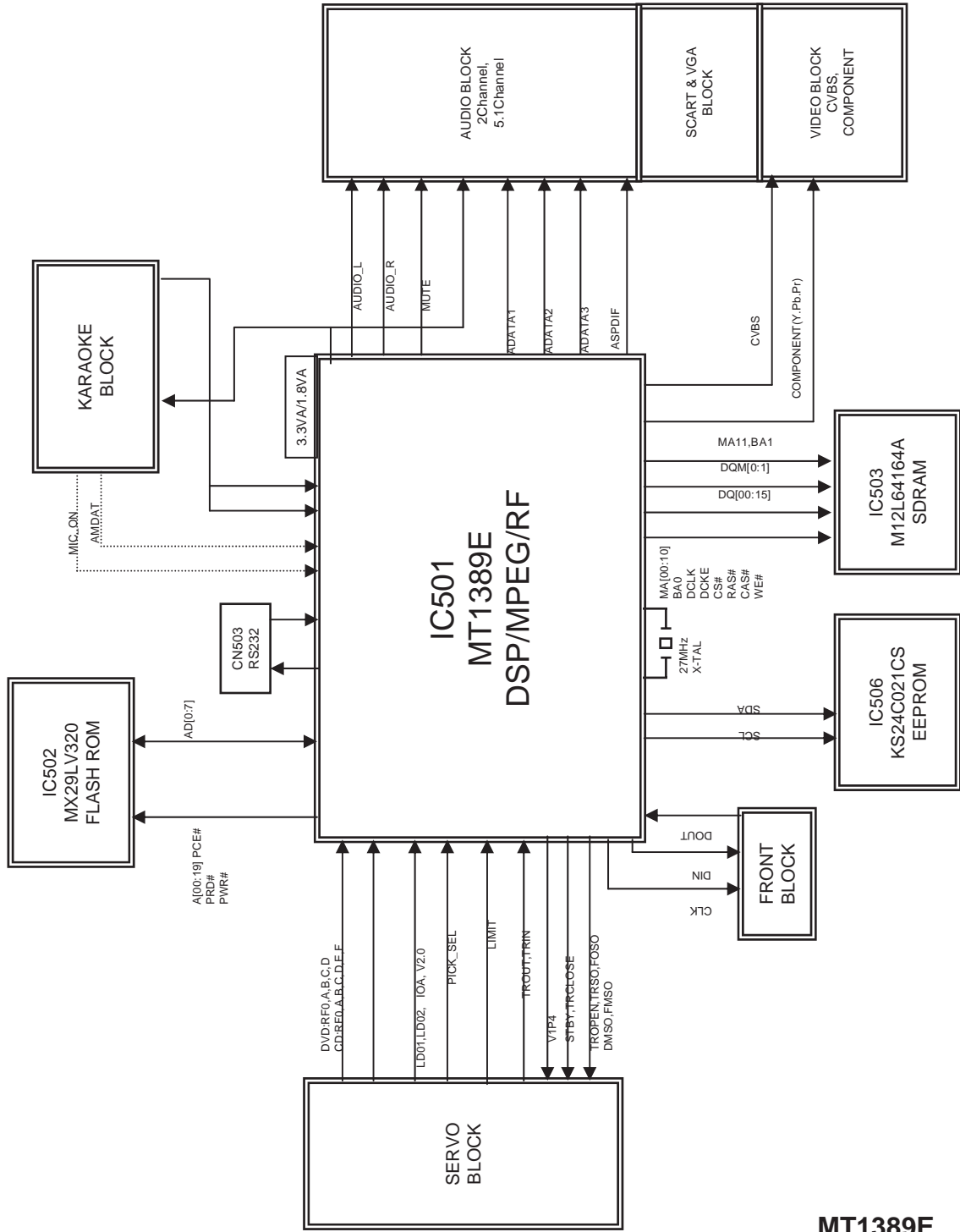

MT1389E

5. VIDEO & AUDIO BLOCK DIAGRAM

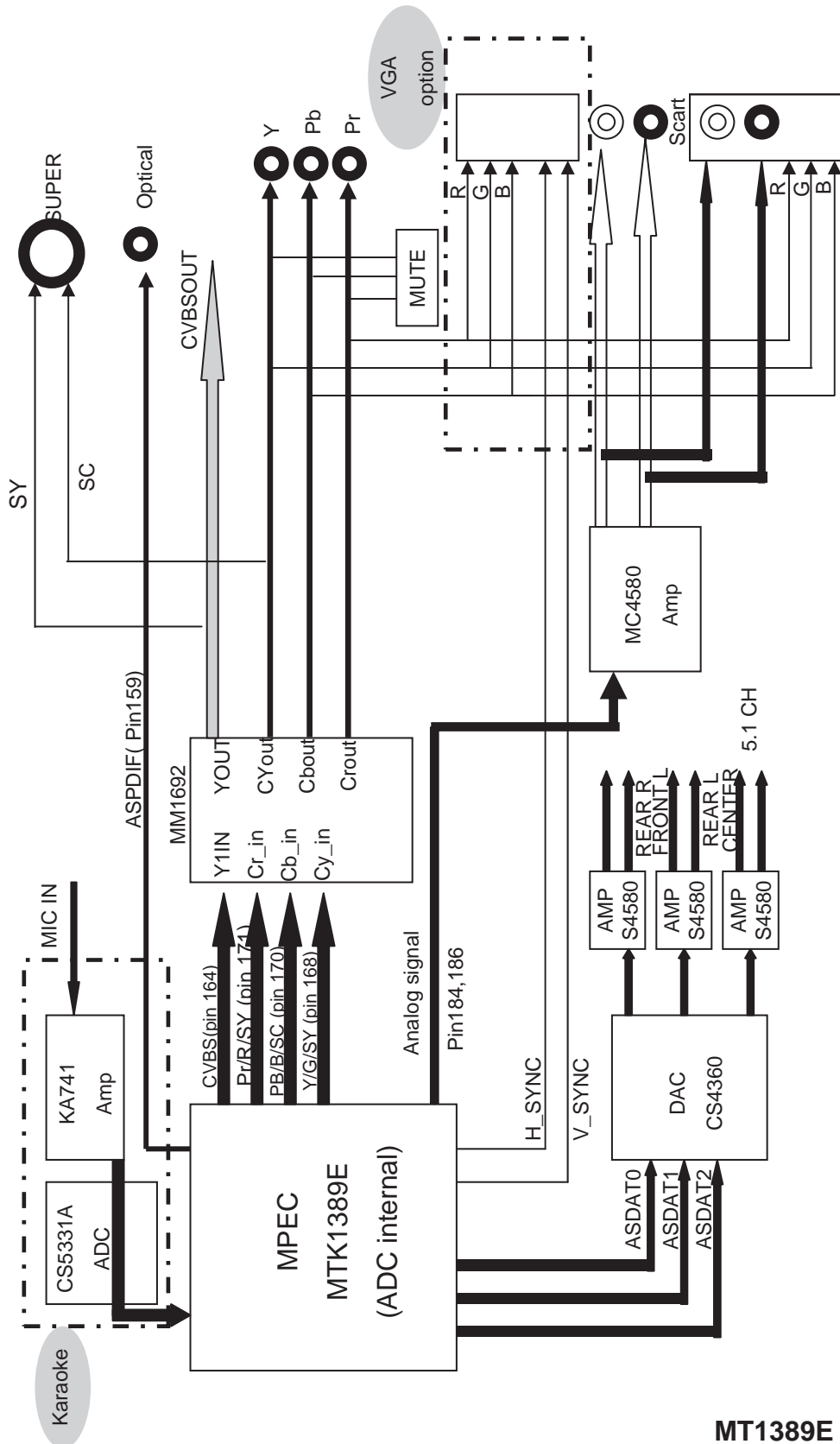

MT1389E

CIRCUIT DIAGRAMS

1. POWER(SMPS) CIRCUIT DIAGRAM

IMPORTANT SAFETY NOTICE

WHEN SERVICING THIS CHASSIS, UNDER NO CIRCUMSTANCES SHOULD THE ORIGINAL DESIGN BE MODIFIED OR ALTERED WITHOUT PERMISSION FROM THE LG ELECTRONICS CORPORATION. ALL COMPONENTS SHOULD BE REPLACED ONLY WITH TYPES IDENTICAL TO THOSE IN THE ORIGINAL CIR-

CUIT. SPECIAL COMPONENTS ARE SHADED ON THE SCHEMATIC FOR EASY IDENTIFICATION. THIS CIRCUIT DIAGRAM MAY OCCASIONALLY DIFFER FROM THE ACTUAL CIRCUIT USED. THIS WAY, IMPLEMENTATION OF THE LATEST SAFETY AND PERFORMANCE IMPROVEMENT CHANGES INTO THE SET IS NOT DELAYED UNTIL THE NEW SERVICE LITERATURE IS PRINTED.

NOTE :

1. Shaded(■) parts are critical for safety. Replace only with specified part number.
2. Voltages are DC-measured with a digital voltmeter during Play mode.

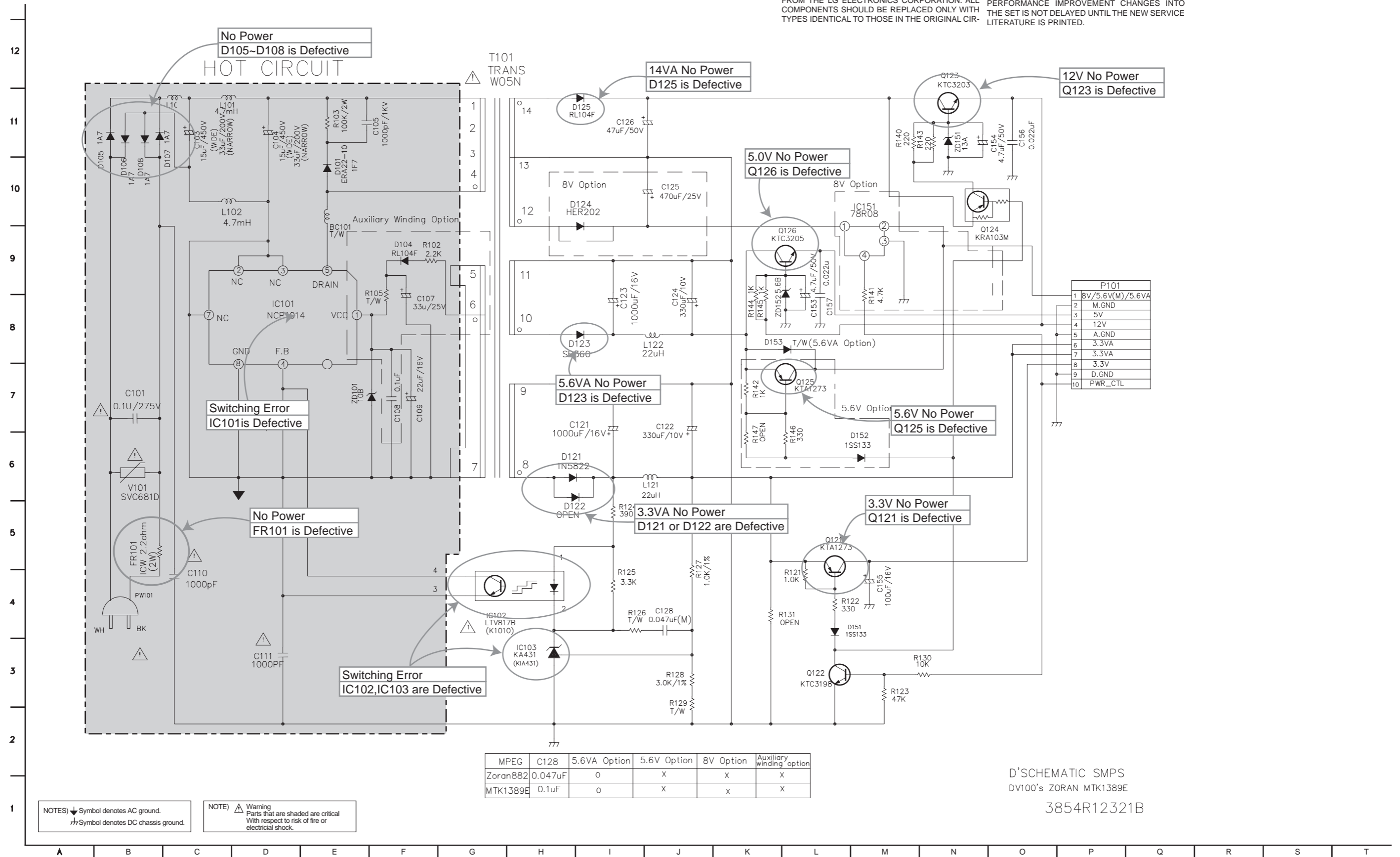

	MPEG	C128	5.6VA Option	5.6V Option	8V Option	Auxiliary winding option
Zoran882		0.047uF	o	x	x	x
MTK1389E		0.1uF	o	x	x	x

D'SCHEMATIC SMPS
 DV100's ZORAN MTK1389E
 3854R12321B

NOTES) ↓ Symbol denotes AC ground.
 ⚡ Symbol denotes DC chassis ground.

NOTE) ⚠ Warning
 Parts that are shaded are critical
 With respect to risk of fire or
 electrical shock.

2. SYSTEM CIRCUIT DIAGRAM

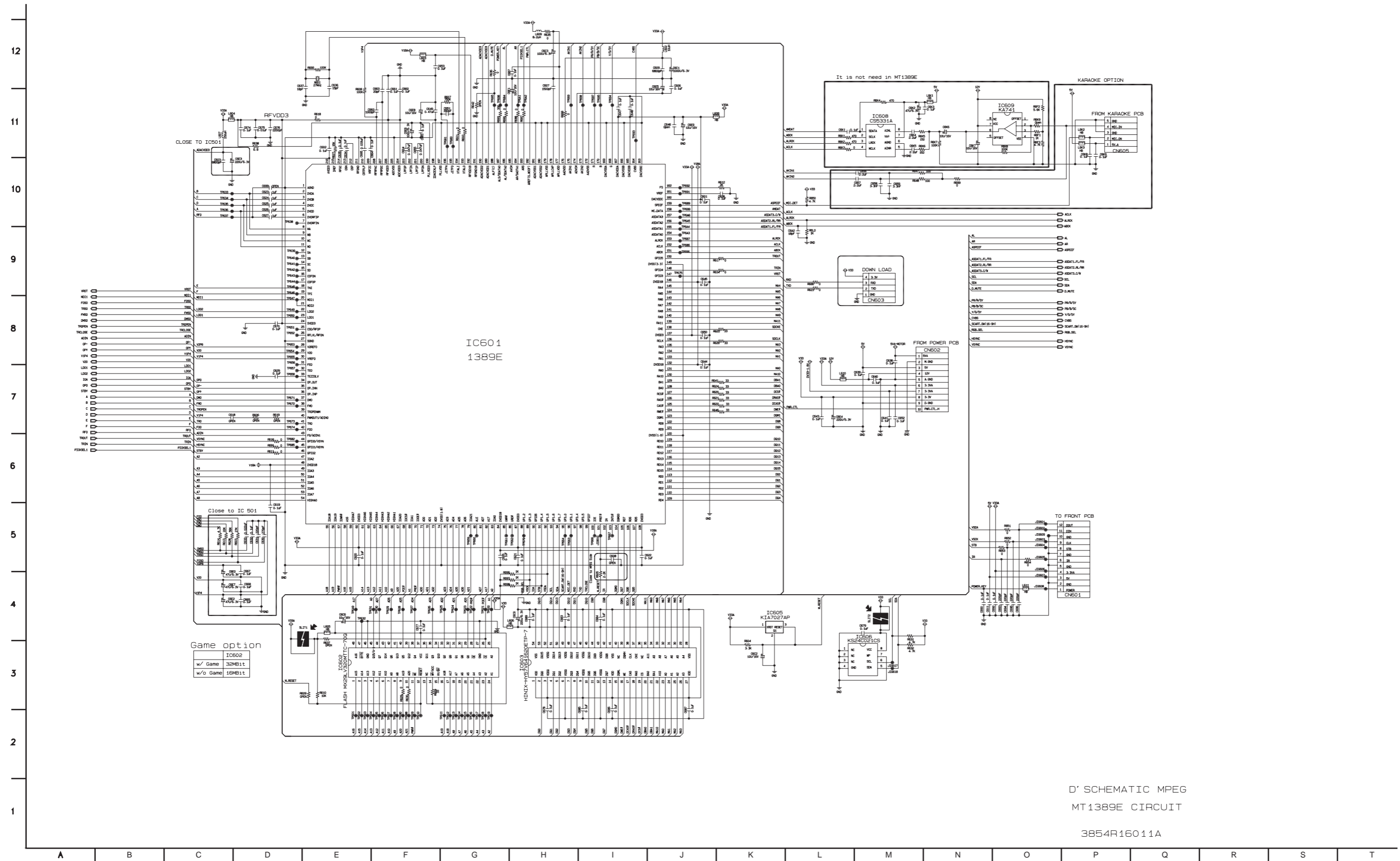

3. SERVO CIRCUIT DIAGRAM

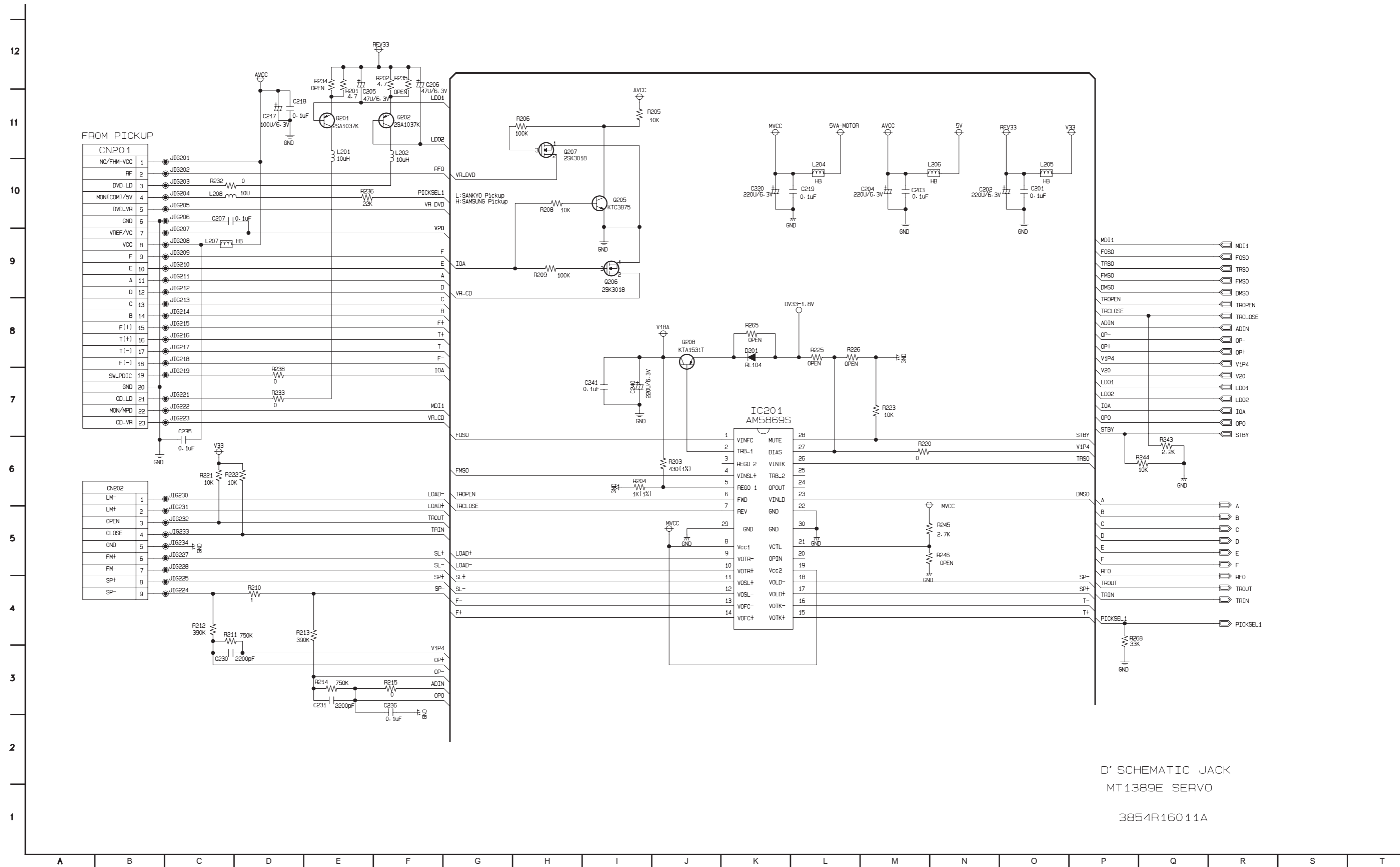

4. AV/JACK CIRCUIT DIAGRAM

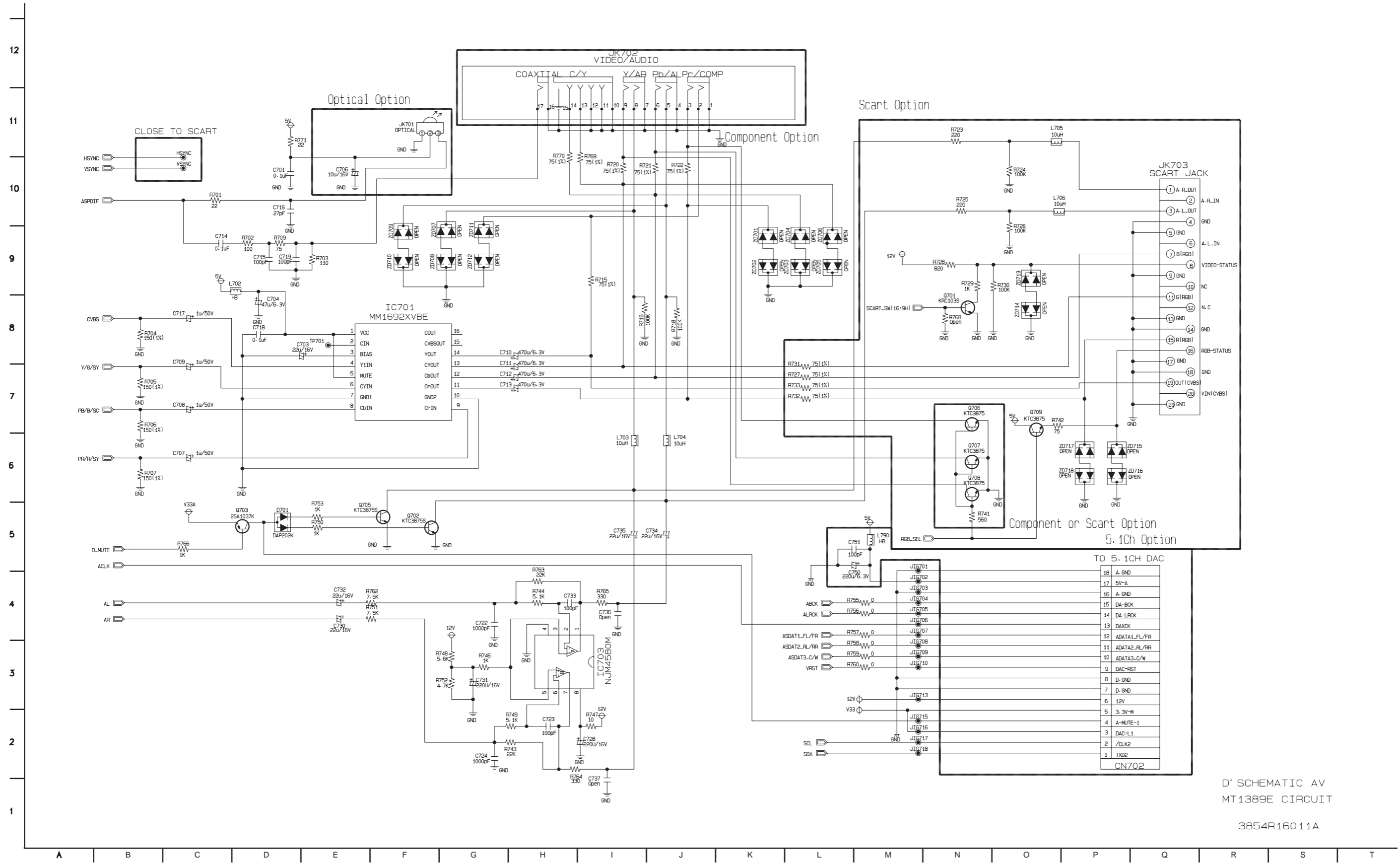

D' SCHEMATIC AV
MT1389E CIRCUIT

3854R16011A

5. TIMER CIRCUIT DIAGRAM (3 TOOL ONLY)

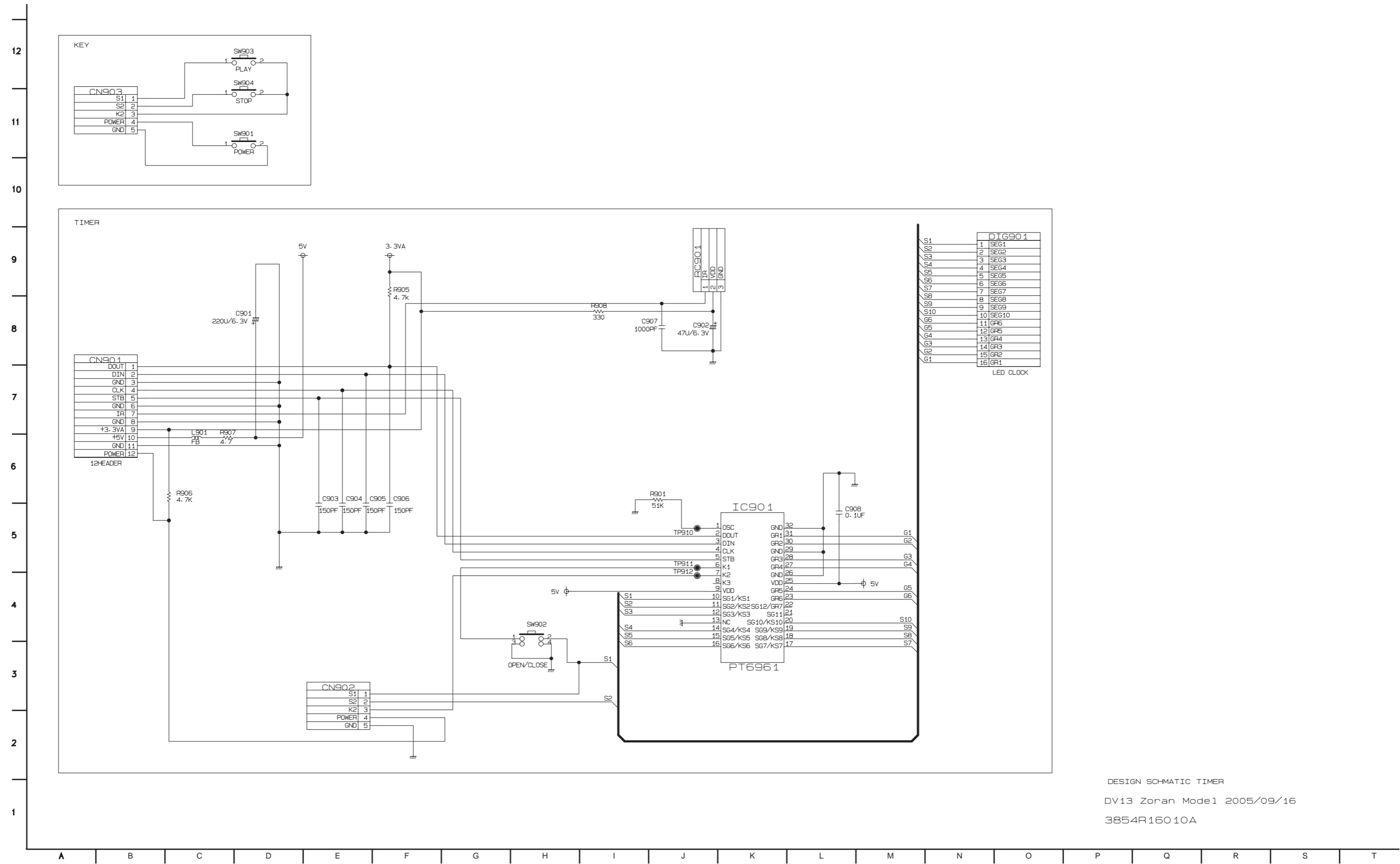

DESIGN SCHMATIC TIMER
DV13 Zoran Model 2005/09/16
3854R16010A

6. TIMER CIRCUIT DIAGRAM (4 TOOL ONLY)

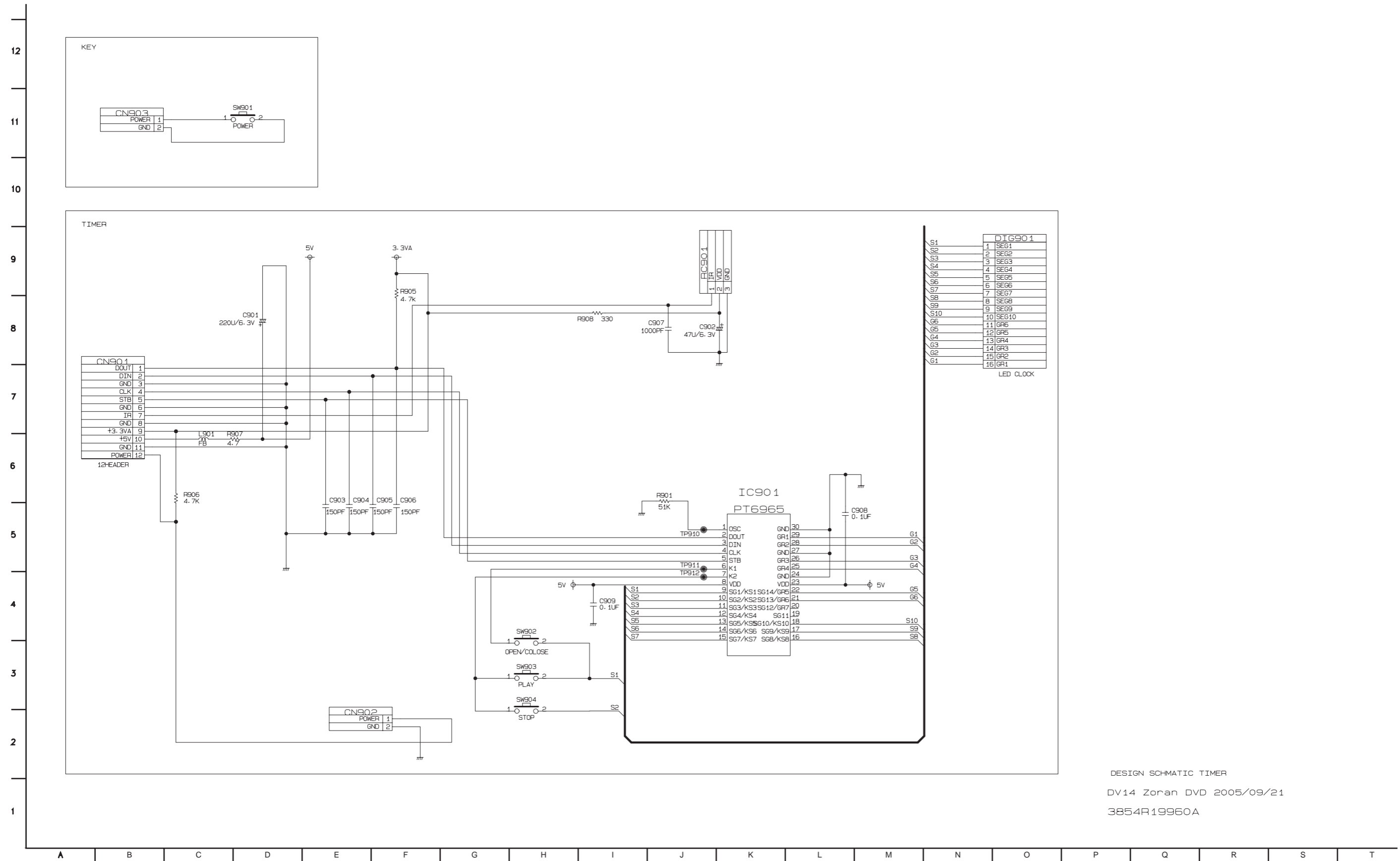

DESIGN SCHEMATIC TIMER

DV14 Zoran DVD 2005/09/21

3854R19960A

7. TIMER CIRCUIT DIAGRAM (6 TOOL ONLY)

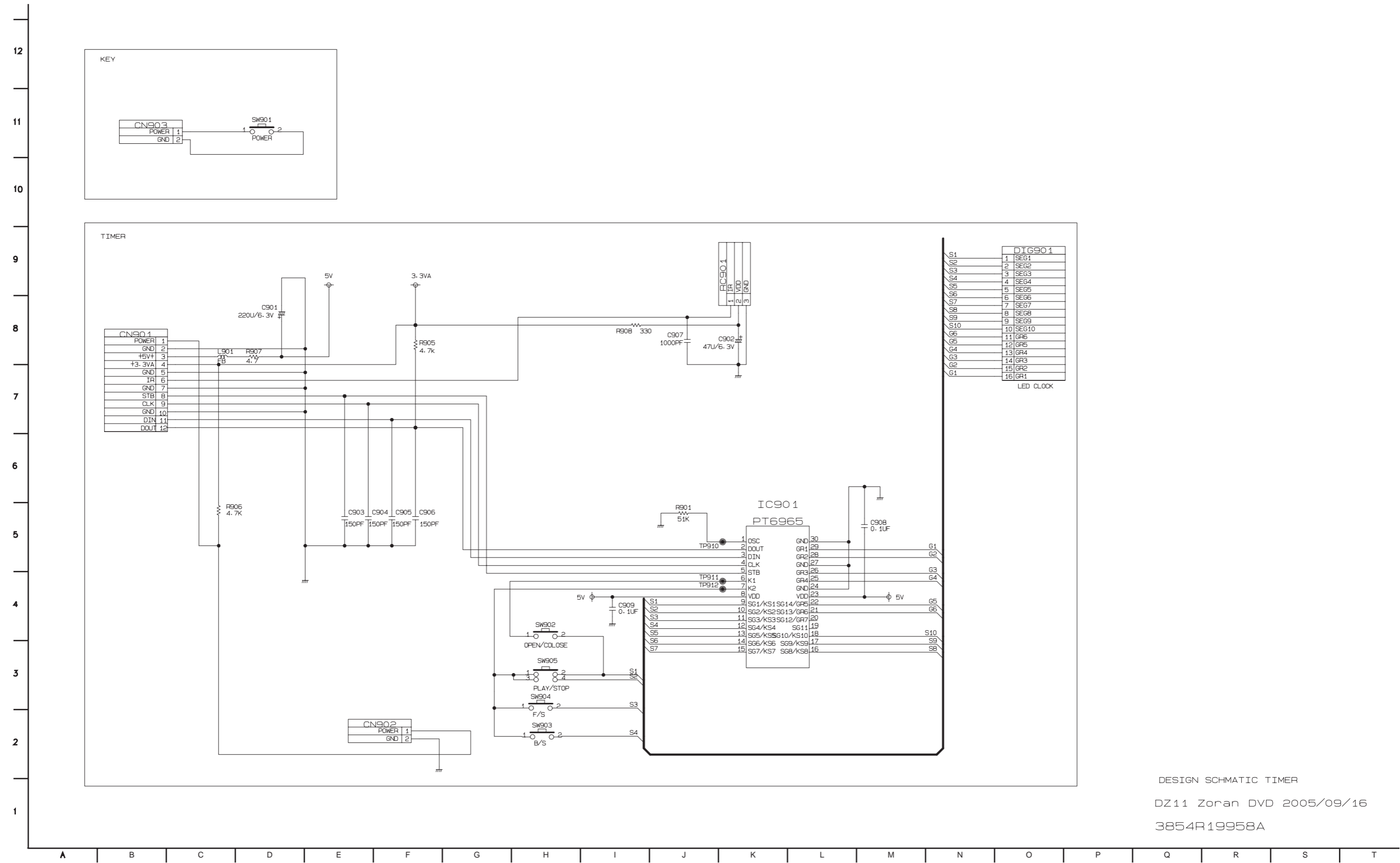

DESIGN SCHEMATIC TIMER
 DZ11 Zoran DVD 2005/09/16
 3854R19958A

8. TIMER CIRCUIT DIAGRAM (7 TOOL ONLY)

12
11
10
9
8
7
6
5
4
3
2
1

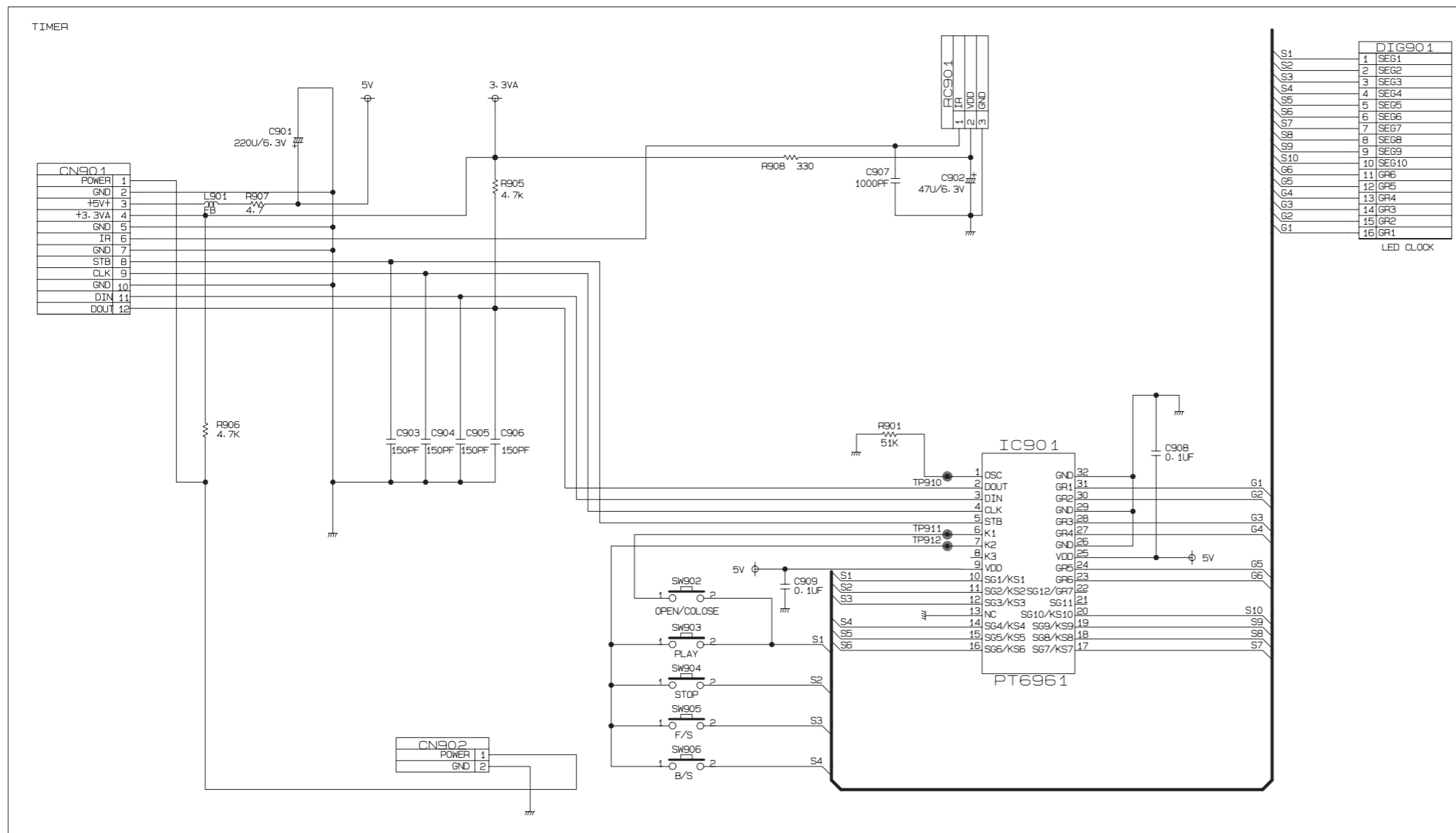
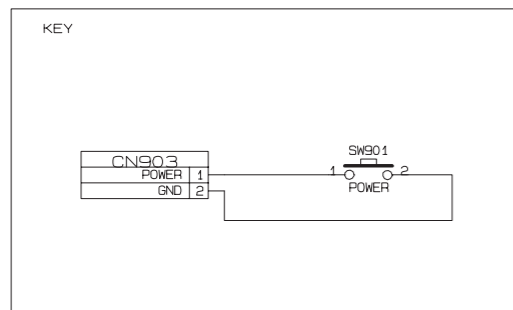

DESIGN SCHMATIC TIMER
DV12 Zoran DVD 2005/09/16
3854R19957A

A B C D E F G H I J K L M N O P Q R S T

9. TIMER CIRCUIT DIAGRAM (8 TOOL ONLY)

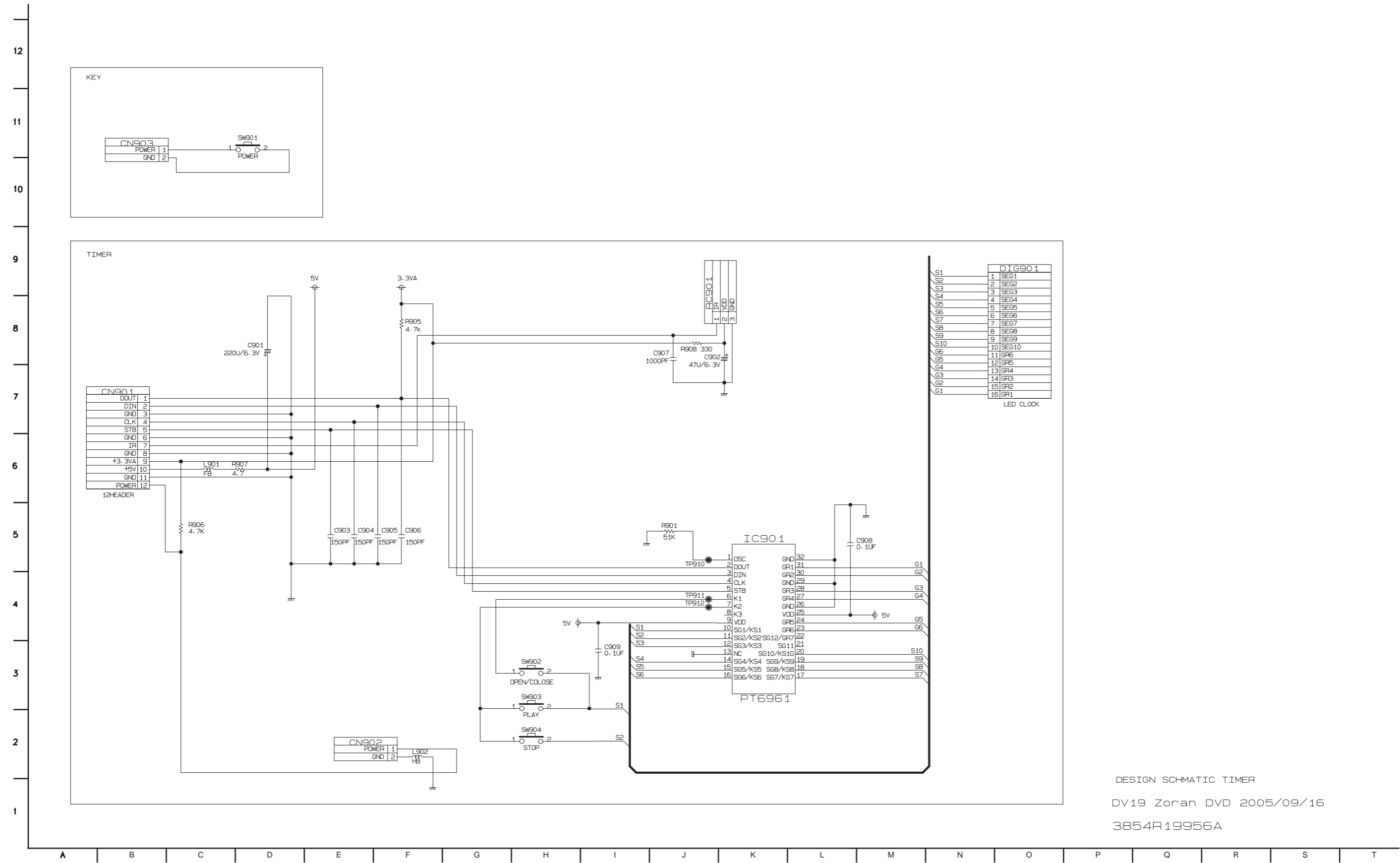

DESIGN SCHEMATIC TIMER
 DV19 Zoran DVD 2005/09/16
 3854R19956A

10. KARAOKE CIRCUIT DIAGRAM (KARAOKE MODEL ONLY)

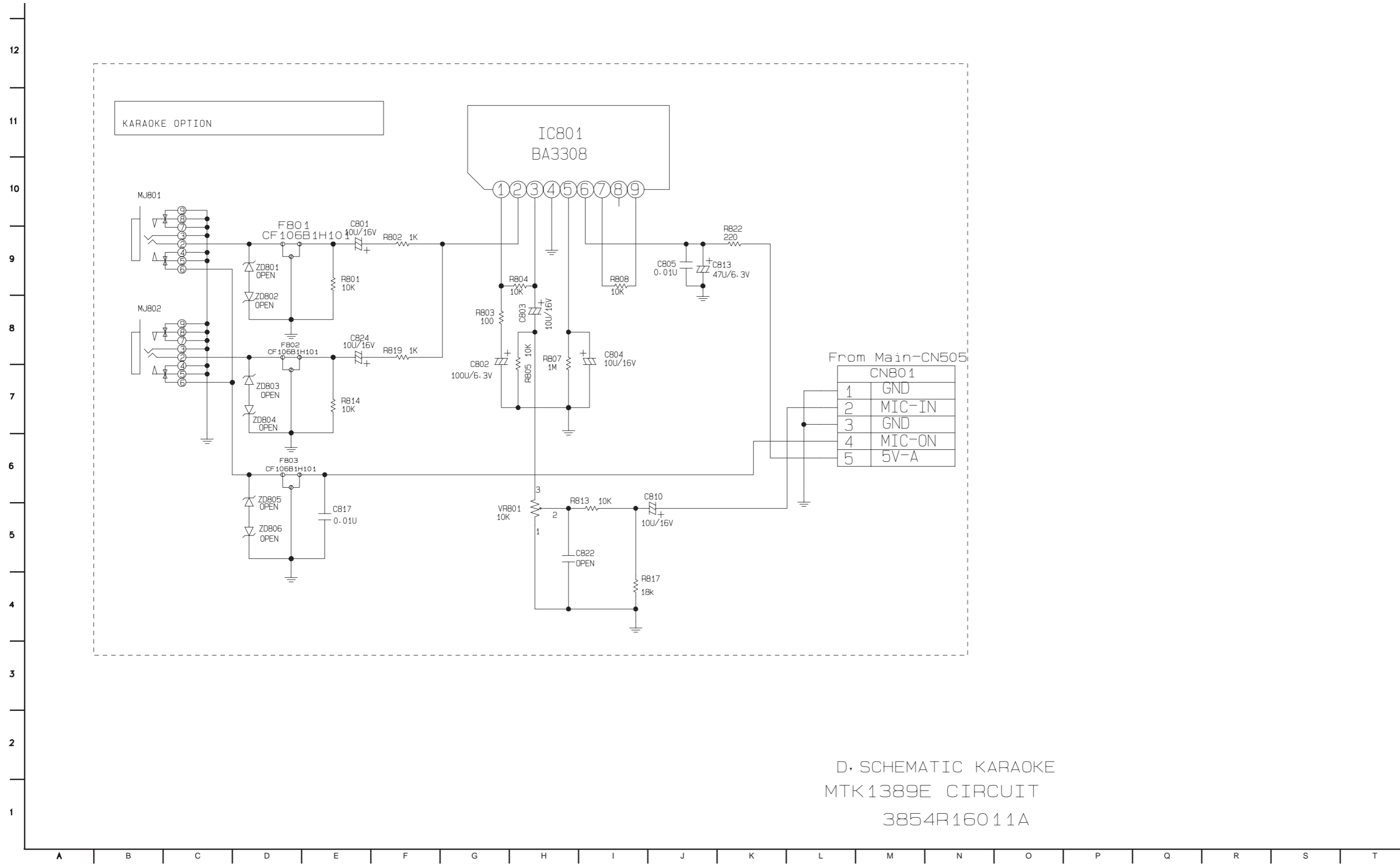

D. SCHEMATIC KARAOKE
 MTK1389E CIRCUIT
 3854R16011A

PRINTED CIRCUIT DIAGRAMS

1. MAIN P.C.BOARD

(TOP VIEW)

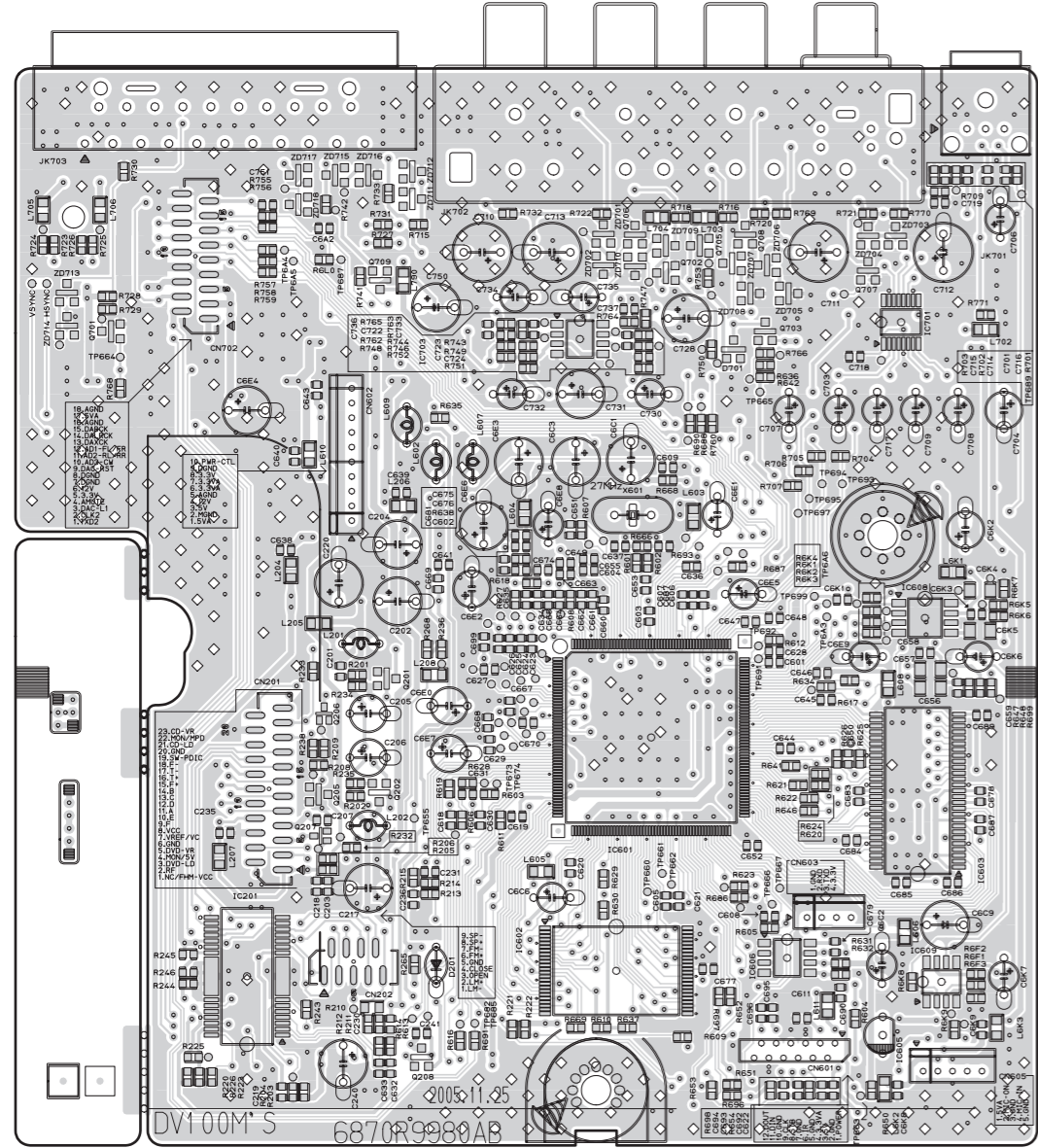

(BOTTOM VIEW)

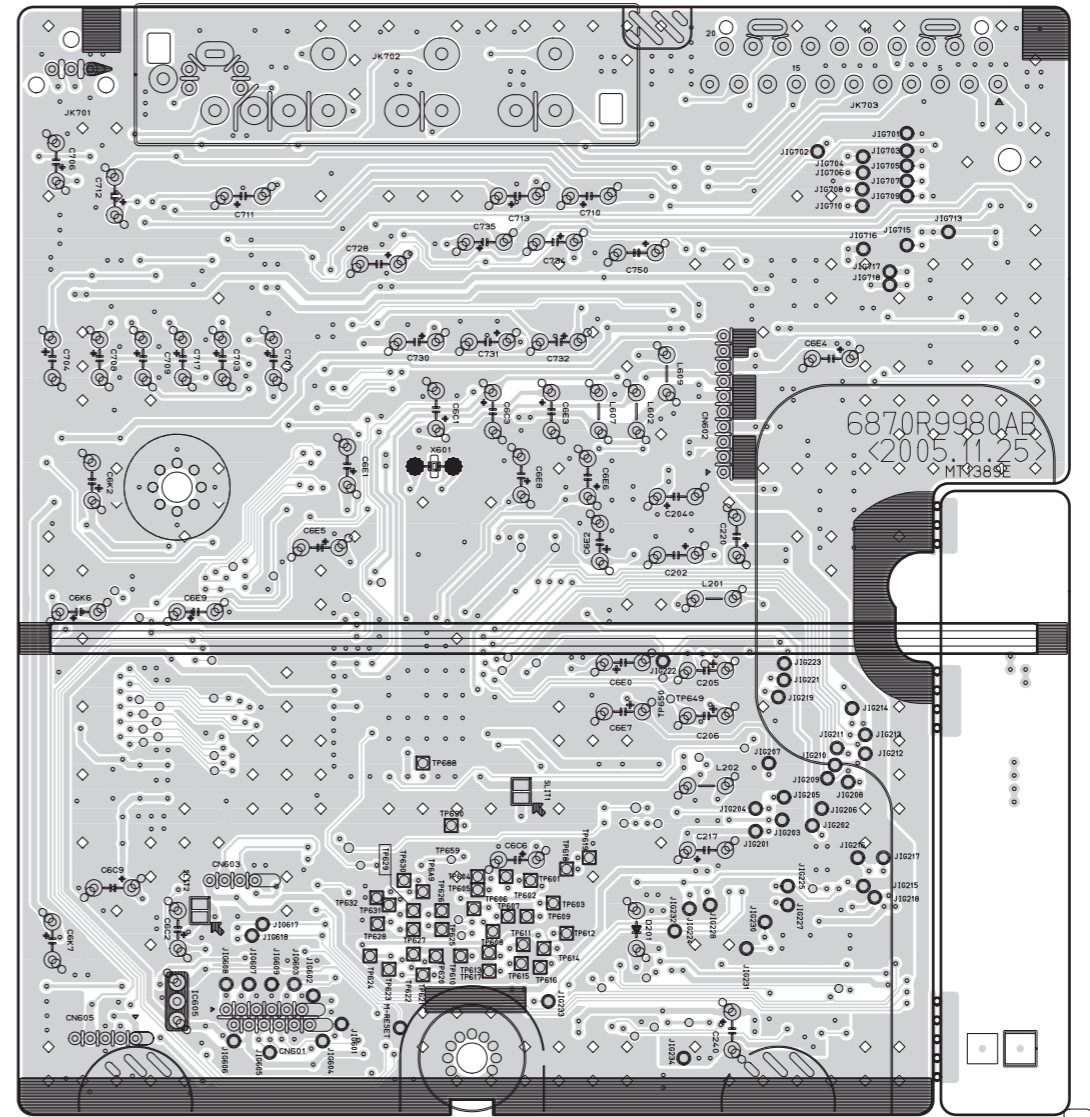

2. KEY P.C.BOARD

(3 TOOL)

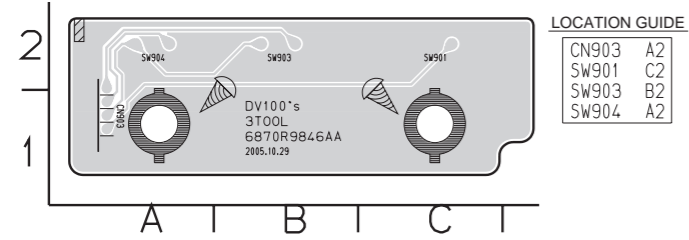

(4 TOOL)

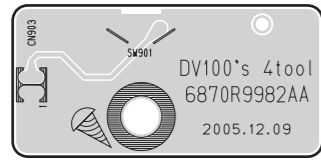

(6 TOOL)

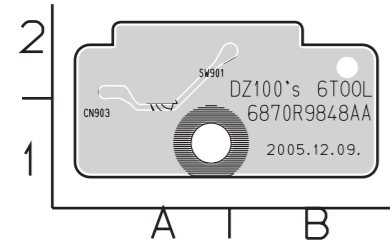

(7 TOOL)

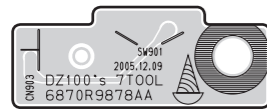

(8 TOOL)

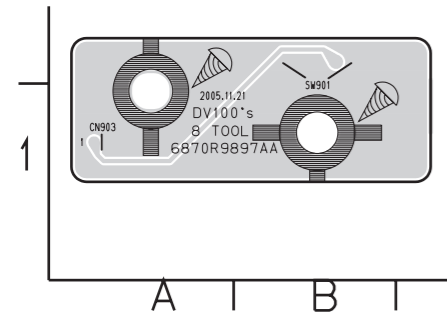

3. TIMER P.C.BOARD

(3 TOOL TOP VIEW)

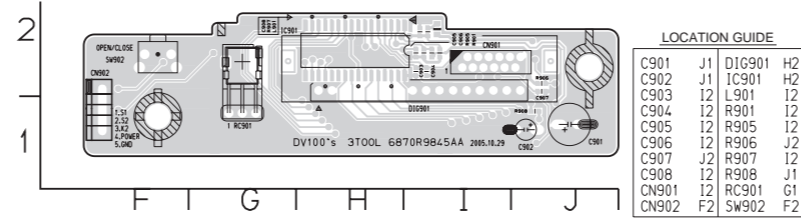

(4 TOOL TOP VIEW)

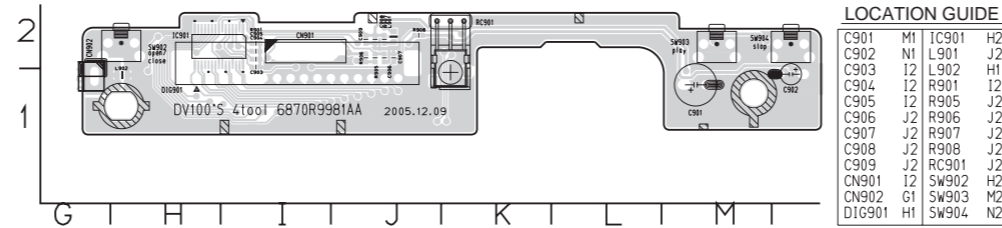

(6 TOOL TOP VIEW)

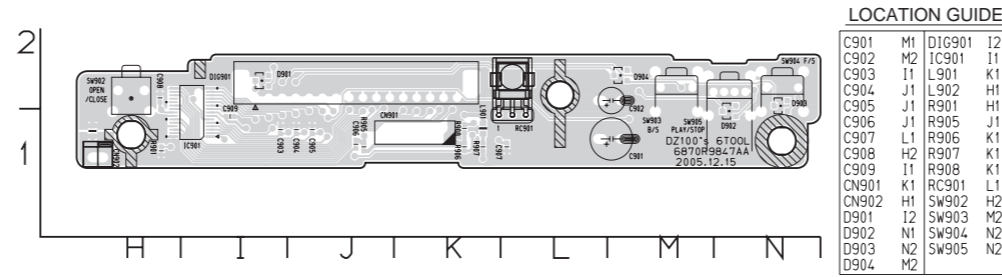

(3 TOOL TOP VIEW)

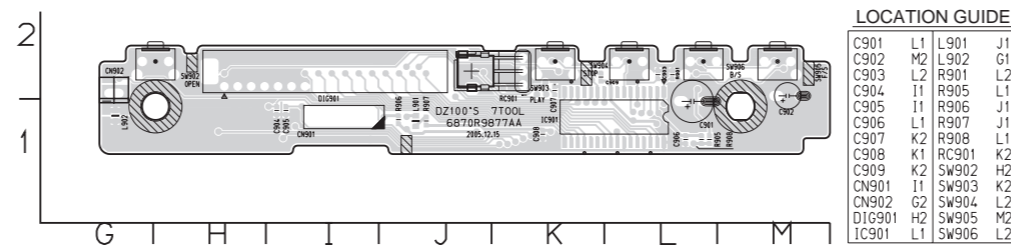

(3 TOOL TOP VIEW)

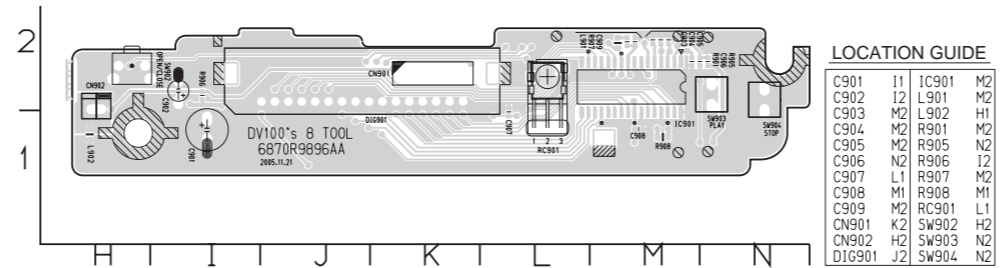

(3 TOOL BOTTOM VIEW)

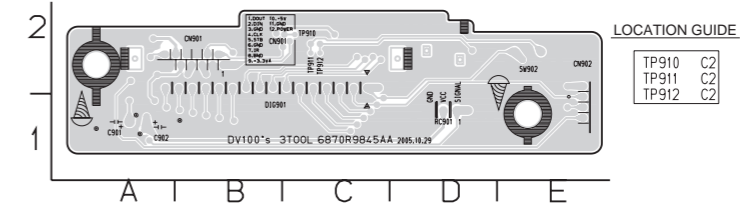

(4 TOOL BOTTOM VIEW)

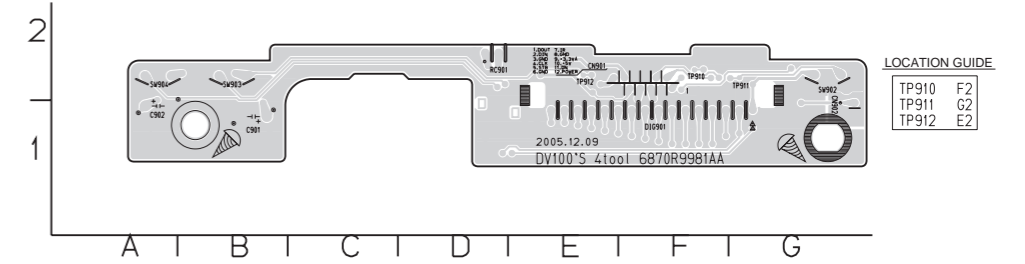

(6 TOOL BOTTOM VIEW)

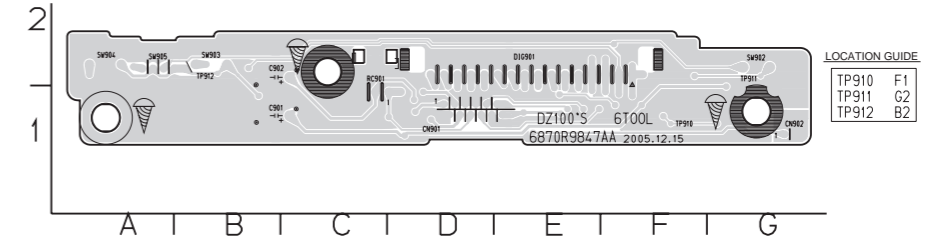

(3 TOOL BOTTOM VIEW)

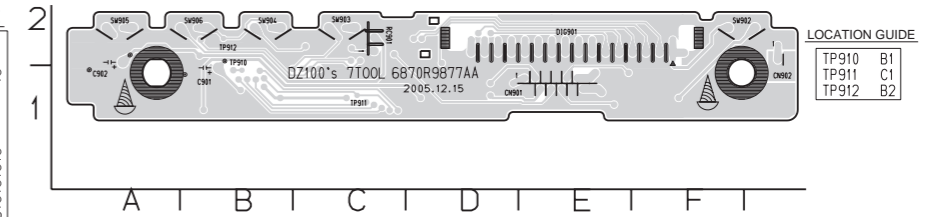

(3 TOOL BOTTOM VIEW)

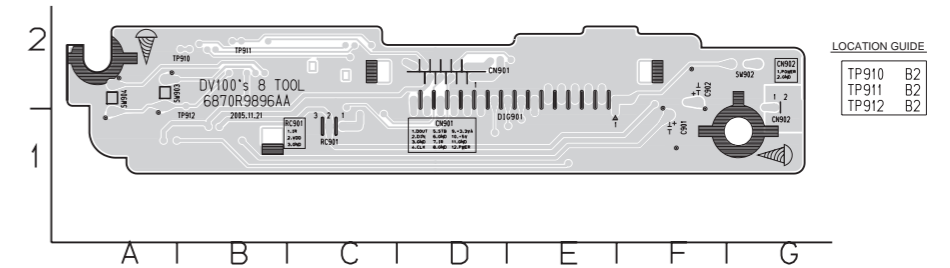

4. SMPS P.C.BOARD(360mm ONLY)

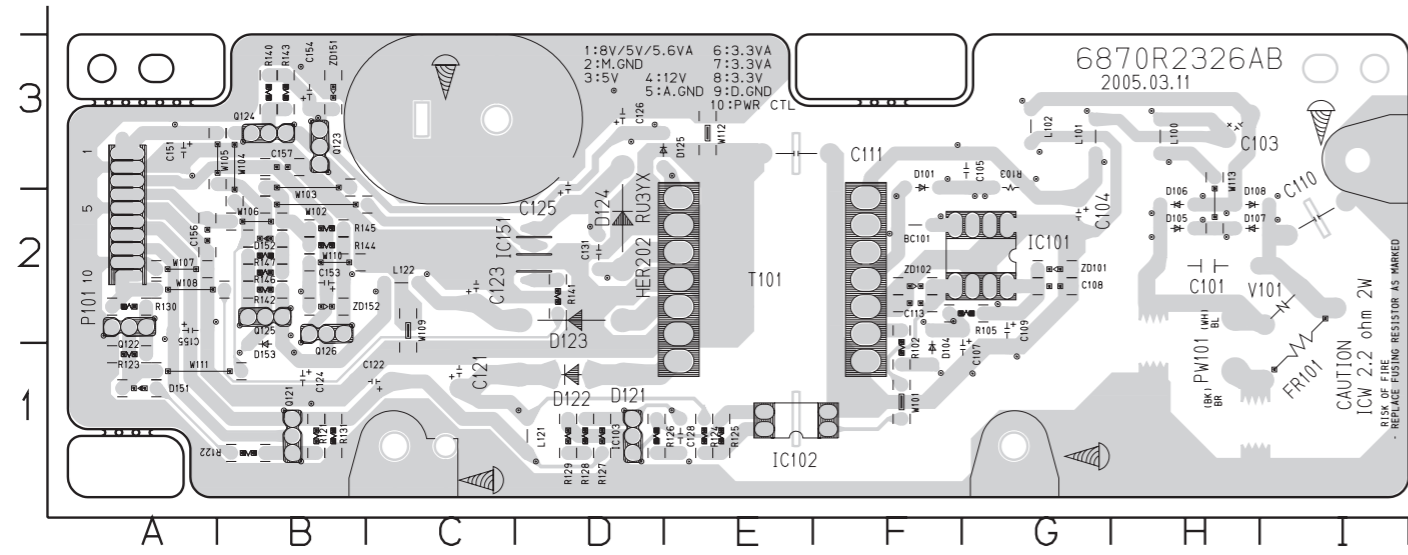

6. JACK P.C.BOARD (OPTIONAL PART)

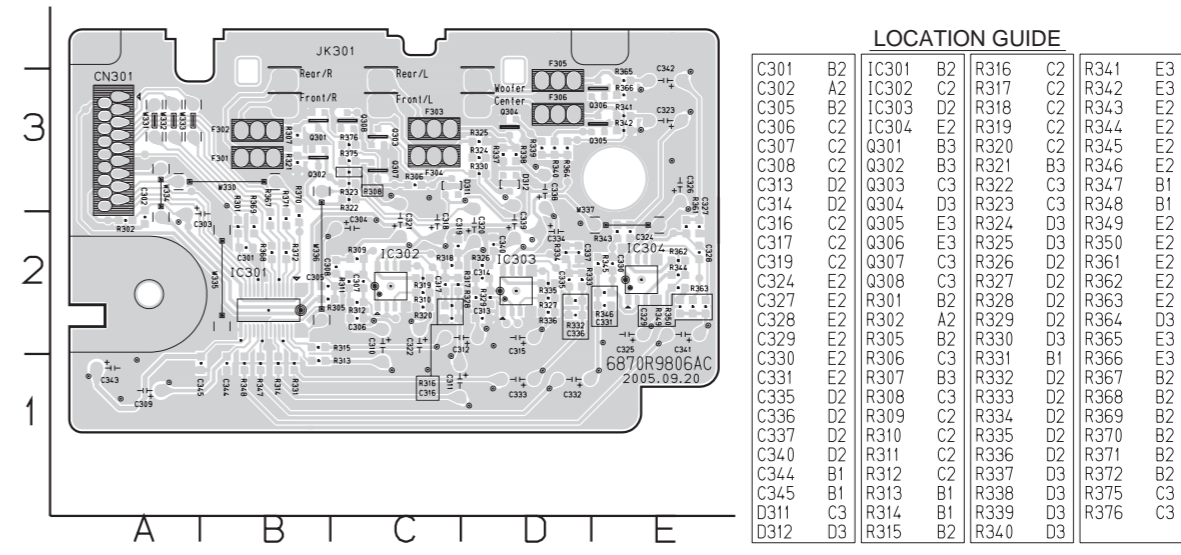

5. SMPS P.C.BOARD(430mm ONLY)

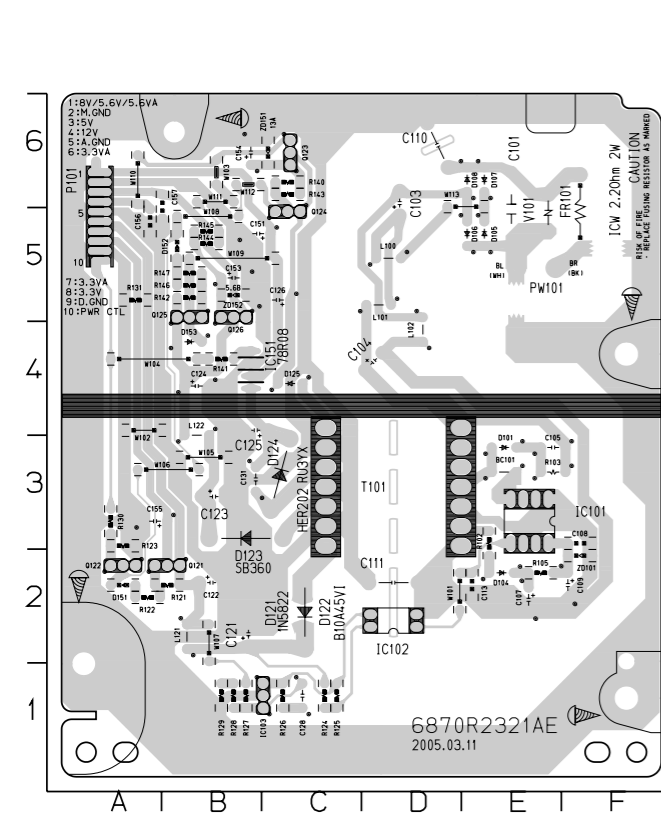

LOCATION GUIDE

BC101	E3	IC103	C1
C101	E5	IC151	B4
C103	D6	L100	D5
C104	D4	L101	D5
C105	E3	L102	D4
C107	E2	L121	B2
C108	F3	L122	B3
C109	F2	P101	A6
C110	D6	PW101	E5
C111	D2	Q121	B2
C113	E2	Q122	A2
C121	B2	Q123	C6
C122	B2	Q124	C5
C123	B3	Q125	B5
C124	B4	Q126	B5
C125	B4	R102	E3
C126	C5	R103	E3
C128	C1	R105	E2
C131	B3	R121	B2
C151	B5	R122	A2
C153	B5	R123	A3
C154	B6	R124	C1
C155	A3	R125	C1
C156	A5	R126	C1
C157	B6	R127	B1
D101	E3	R128	B1
D104	E2	R129	B1
D105	E5	R130	A3
D106	E5	R131	A5
D107	E6	R140	C6
D108	E6	R141	B4
D121	C2	R142	B5
D122	C2	R143	C6
D123	B3	R144	B5
D124	C3	R145	B5
D125	C4	R146	B5
D151	A2	R147	B5
D152	B5	T101	D3
D153	B4	V101	E5
FR101	F5	ZD101	F2
IC101	E3	ZD151	C6
IC102	D2	ZD152	B5

7. KARAOKE P.C.BOARD (KARAOKE MODEL ONLY)

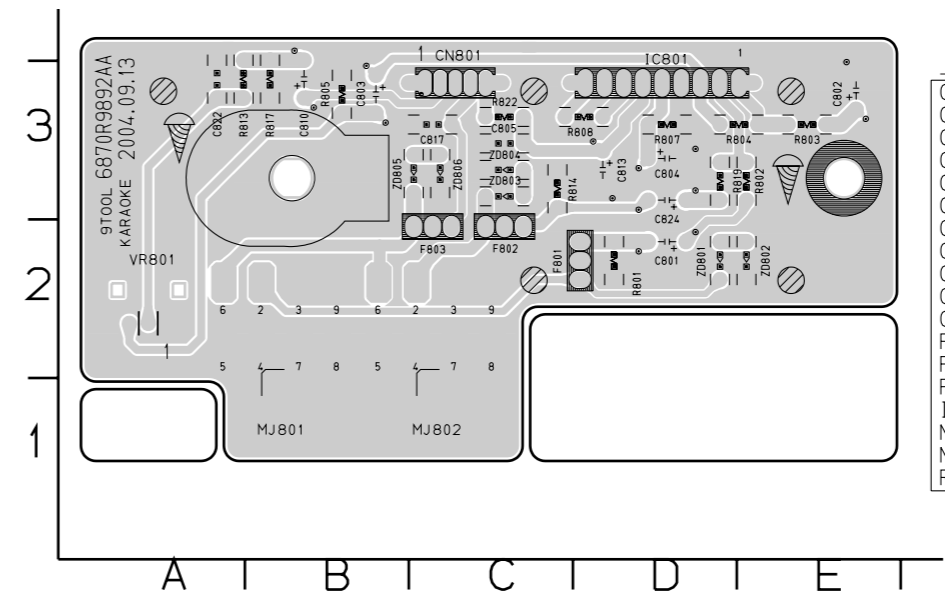

LOCATION GUIDE

C801	D2	R802	E3
C802	E3	R803	E3
C803	B3	R804	E3
C804	D3	R805	B3
C805	C3	R807	D3
C810	B3	R808	D3
C813	D3	R813	A3
C817	C3	R814	C3
C822	A3	R817	B3
C824	D3	R819	D3
CN801	C3	R822	C3
F801	D2	VR801	A2
F802	C2	ZD801	D2
F803	C2	ZD802	E2
IC801	E3	ZD803	C3
MJ801	B1	ZD804	C3
MJ802	C1	ZD805	C3
R801	D2	ZD806	C3