

FRU (Field Replaceable Unit) List

Chapter 6

Part List

Picture	Part name	Description	Vendor Part No.
	FUNCTION BUTTON BOARD	PCBA FOR ,A190A2-H,A190A2-H-K2,106-02,REV.01	35-D003068
	Lips	Lips Without Audio, DAC-19M009 BF	27-D008552
	Main Board	PCBA for ,A220Z1-Z01-H,A170E2-E03-H-S6,1101-01,Rev.04	35-D007790
	CABLES	FFC,15 Pins, A220Z1-H02,OSD_FFC	32-D009095
	CABLE	FFC,CFC2128/862P0600 68D,36 Pins	32-D008479
	MONITOR CABLE	Accessory Cable,D-Sub,BLACK	32F3018003

Picture	Part name	Description	Vendor Part No.
	STAND BASE	Stand Assy,A220Z1-H02,	40-D009177
	LCD FRONT BEZEL	Bezel Assy,A220Z1-H02	40-D009188
	LCD BACK COVER	Rear Assy,A220Z1-H02	40-D009181
	LCD STAND NECK	Stand Assy,A220Z1-H02	40-D009177
	Hinge Cover	Cover Hinge Assy,A220Z1-H02	40-D009185
	Support Plate	Support Plate,A220Z1-H02	41-D009178
	Cover AD	Cover AD Assy,A190A2	41-D008025

Item	Parts Name	Q'ty
1	Backlight Unit, A220Z1	1
2	PANEL_ASSY_A220Z1-L01	1
3	Metal Frame Front,M220Z1-L01	1
4	Lips Without Audio	1
5	PCBA for,A220Z1-Z01-T	1
6	FFC,CFC2128/862P060068D,36 Pins	2
7	SCREW,M3,P=0.5mm, L=2.5mm	3
8	SCREW,M3,P=0.5mm, L=4mm	13
9	SCREW,M4 ,P=0.7mm, L=8mm	1
10	FFC,15Pins,A220Z1-H02,OSD	1
11	Cover AD Assy,A190A2	1
12	SCREW,M4 ,P=0.7mm, L=11.8mm	2
13	Support Plate,A220Z1-H02	1
14	Bezel Assy,A220Z1-H02	1
15	PCBA for ,A190A2-H-K2	1
16	Rear Assy,A220Z1-H02	1
17	SCREW_M3*8L_PWH_PHC	4
18	SCREW,M3 ,P=1.27mm, L=8mm	1
19	Stand Assy,A220Z1-H02	1
20	SCREW,M4 ,P=0.7mm, L=15mm	4
21	Cover Hinge Assy,A220Z1-H02	2
22	Seat Assy,A220Z1-H02	1

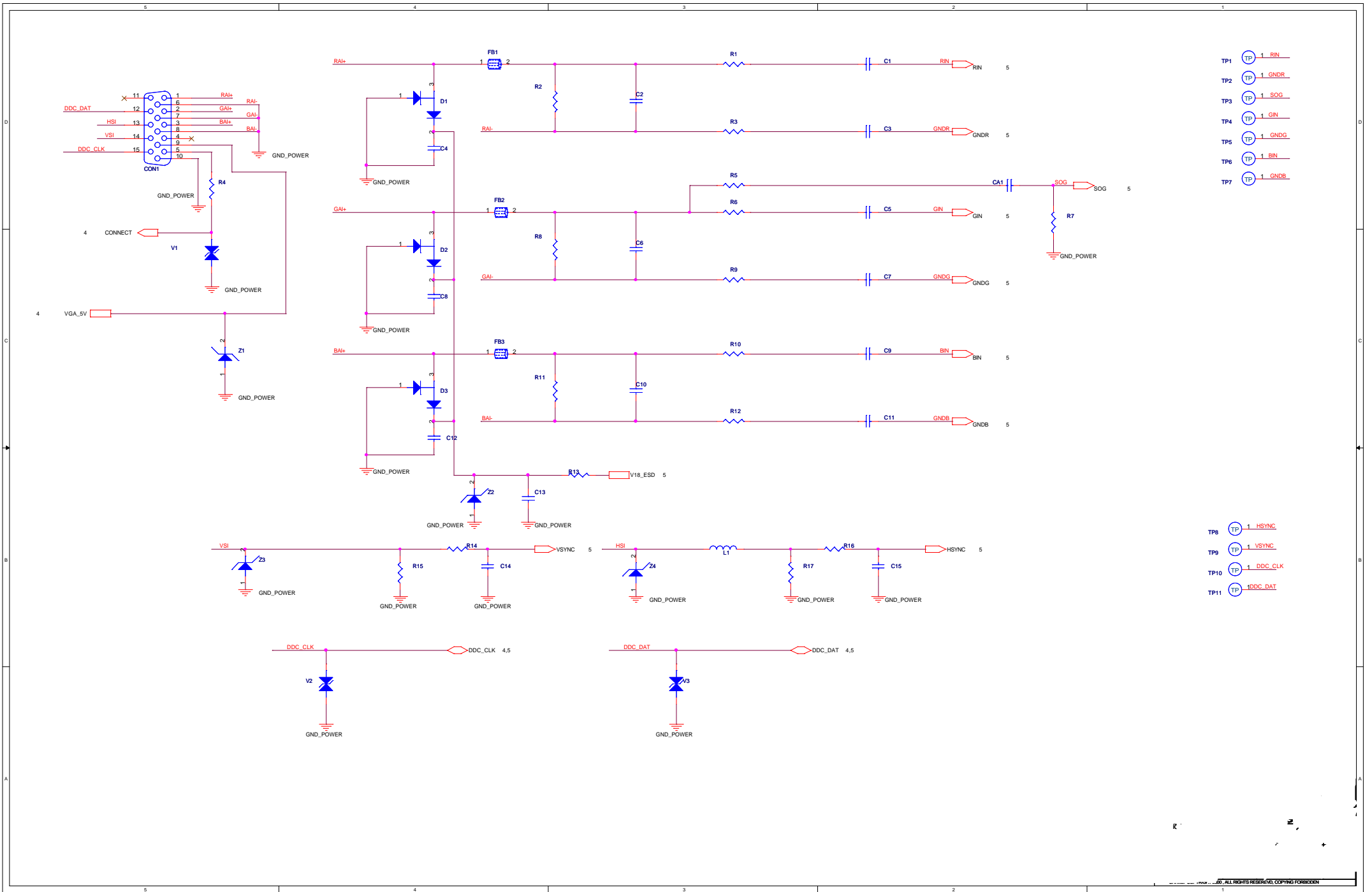

- TP1 TP -1 RIN
- TP2 TP -1 GNDR
- TP3 TP -1 SOG
- TP4 TP -1 GIN
- TP5 TP -1 GNDG
- TP6 TP -1 BIN
- TP7 TP -1 GNDB

- TP8 TP 1 HSYNC
- TP9 TP 1 VSYNC
- TP10 TP 1 DDC_CLK
- TP11 TP 1 DDC_DAT

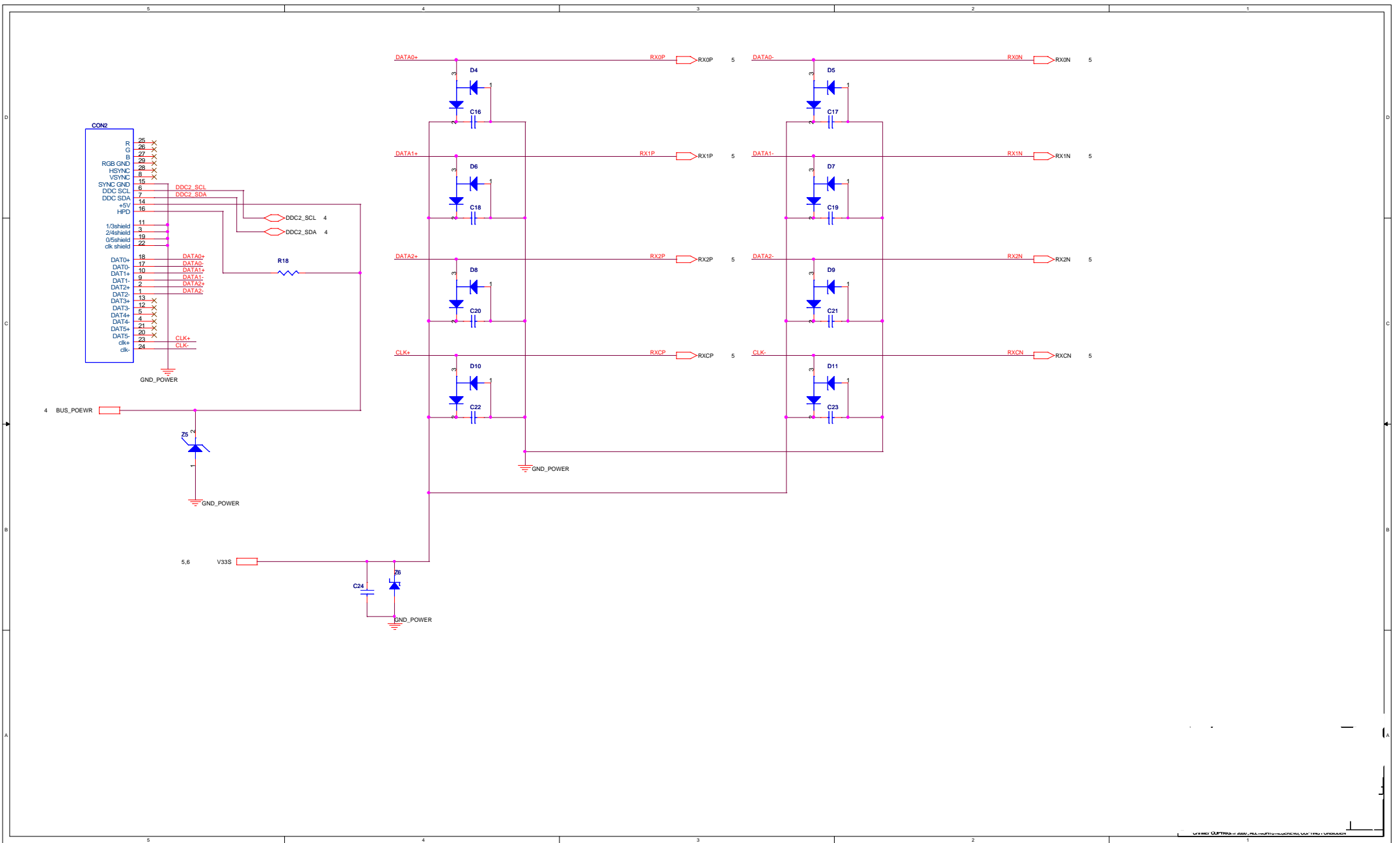

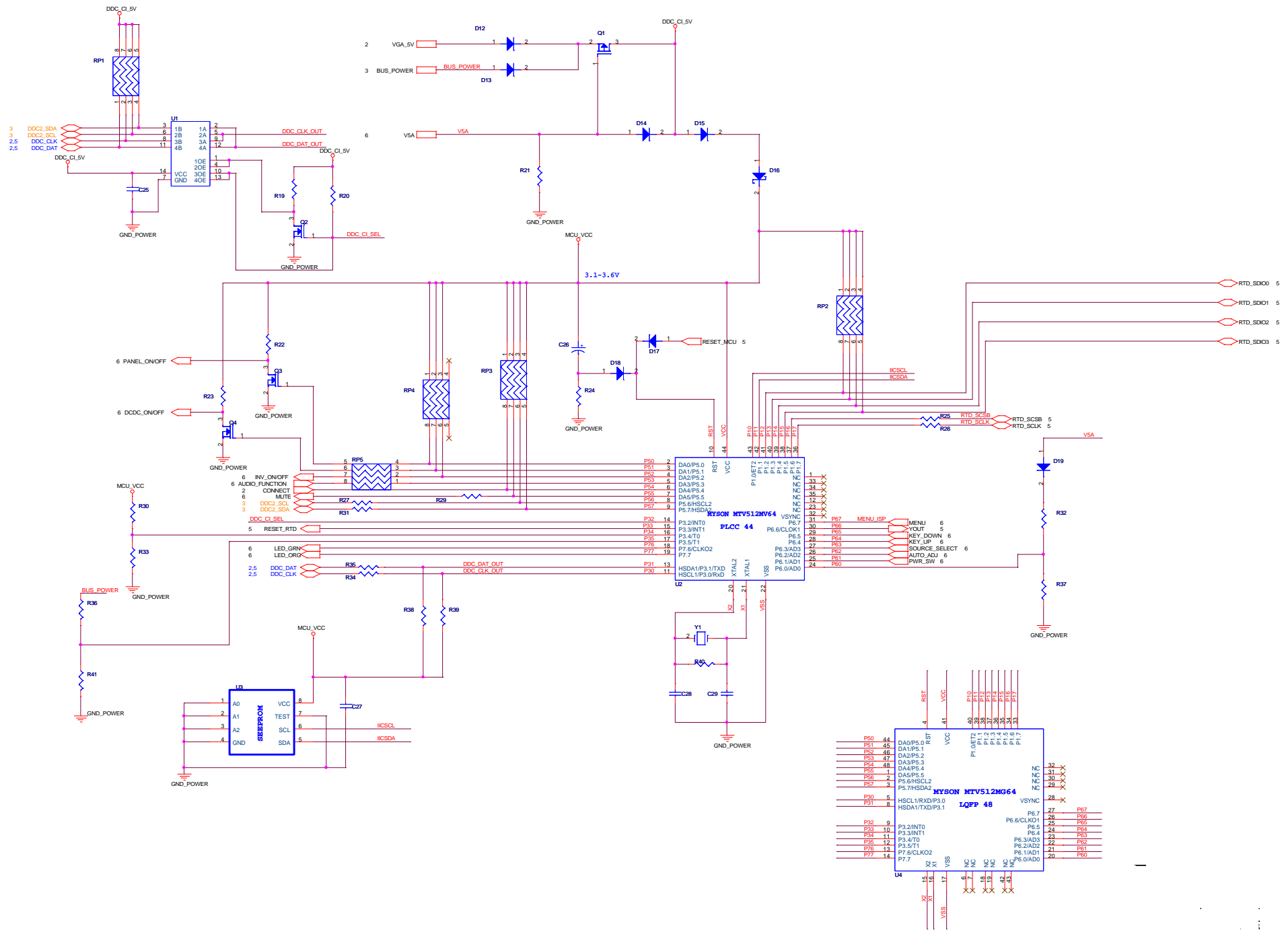

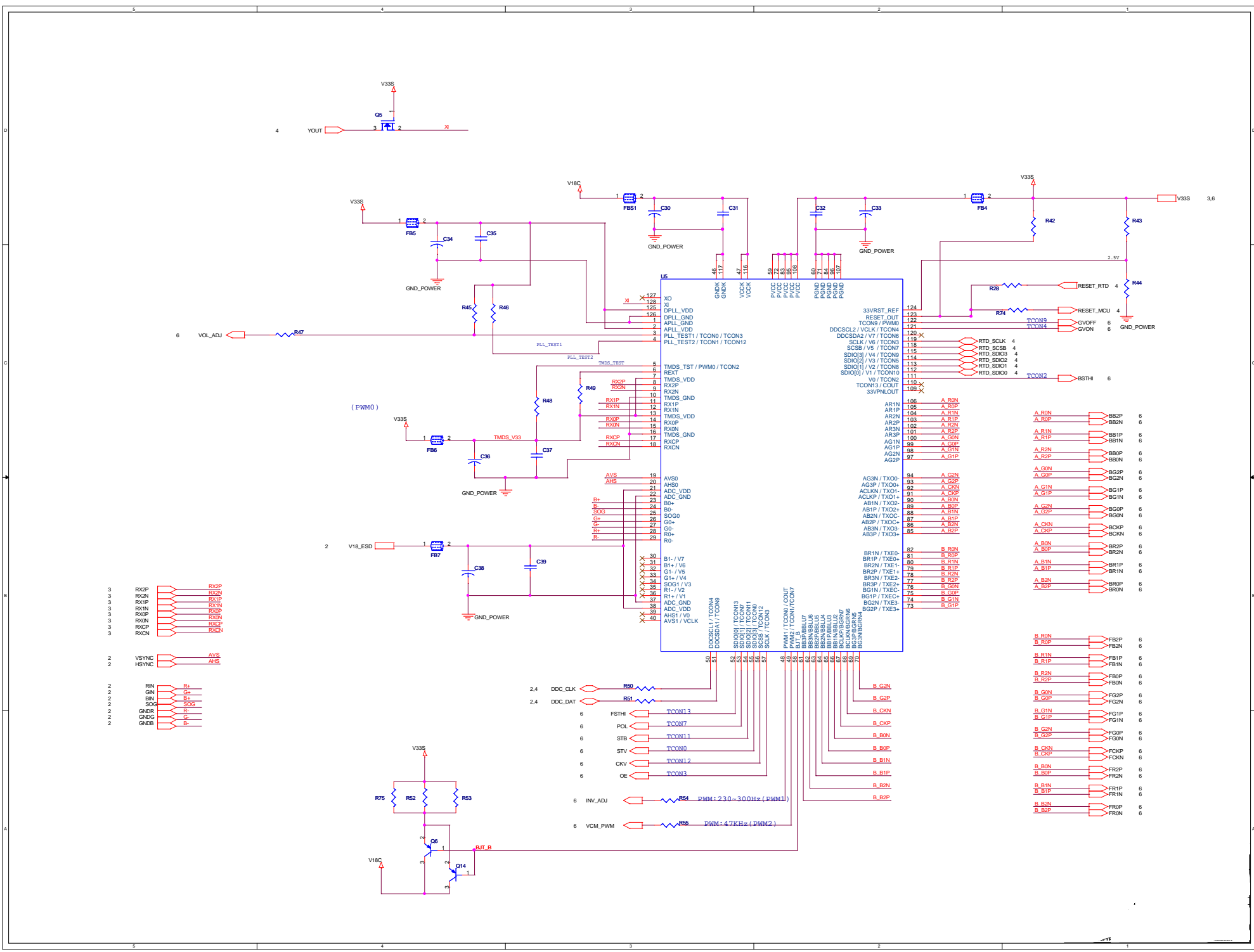

- 3 RXCP
- 3 RXCN
- 3 RXIP
- 3 RXIN
- 3 RXOP
- 3 RXON
- 3 RXCP
- 3 RXCN
- 3 RXIP
- 3 RXIN
- 3 RXOP
- 3 RXON
- 3 RXCP
- 3 RXCN
- 2 VSYNC
- 2 HSYNC
- 2 RIN
- 2 GIN
- 2 BIN
- 2 SOG
- 2 GNER
- 2 GNDG
- 2 GNDG
- 2 GNDG

- R+
- G+
- B+
- SOG
- R-
- G-
- B-

- A_R0N
- A_R0P
- A_R1N
- A_R1P
- A_R2N
- A_R2P
- A_R3N
- A_R3P
- A_G0N
- A_G0P
- A_G1N
- A_G1P
- A_G2N
- A_G2P
- A_G3N
- A_G3P
- A_C0N
- A_C0P
- A_C1N
- A_C1P
- A_C2N
- A_C2P
- A_C3N
- A_C3P
- B_R0N
- B_R0P
- B_R1N
- B_R1P
- B_R2N
- B_R2P
- B_R3N
- B_R3P
- B_G0N
- B_G0P
- B_G1N
- B_G1P
- B_G2N
- B_G2P
- B_G3N
- B_G3P
- B_C0N
- B_C0P
- B_C1N
- B_C1P
- B_C2N
- B_C2P
- B_C3N
- B_C3P
- B_B0N
- B_B0P
- B_B1N
- B_B1P
- B_B2N
- B_B2P
- B_B3N
- B_B3P

- B_G2N
- B_G2P
- B_C0N
- B_C0P
- B_C1N
- B_C1P
- B_C2N
- B_C2P
- B_G0N
- B_G0P
- B_G1N
- B_G1P
- B_G2N
- B_G2P
- B_C0N
- B_C0P
- B_C1N
- B_C1P
- B_C2N
- B_C2P
- B_B0N
- B_B0P
- B_B1N
- B_B1P
- B_B2N
- B_B2P
- B_B3N
- B_B3P

