

INFRARED REMOTE CONTROL TRANSMITTER

DESCRIPTION

SC9012 is an infrared remote control transmitter utilizing CMOS Technology specially designed for use on infrared remote control applications. It is capable of controlling 32 function keys and 6 double keys. Each system has a maximum of 8 commands; thus, SC9012 can provide up to a total of 256 commands.

The pin assignments and application circuit are optimized for easy PCB Layout and cost saving advantage. SC9012 is housed in a 20-pins SO package.

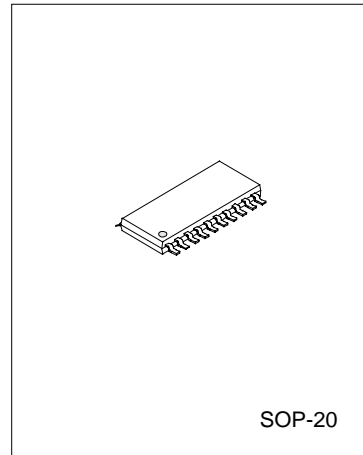

FEATURES

- * CMOS Technology
- * Low Power Consumption
- * Built-in Oscillation Circuit
- * Least External Components
- * 32 Function Keys, 8 Customer Codes (Up to 256 Commands)
- * 6 Double Function Keys
- * LED Indication of Transmission

ORDERING INFORMATION

SC9012	SOP-20 Package
--------	----------------

APPLICATIONS

- * Infrared Remote Control Transmitter Equipment
- * Television Remote control Equipment
- * VCR Remote control Equipment
- * VCD, Audio Equipment

PIN CONFIGURATION

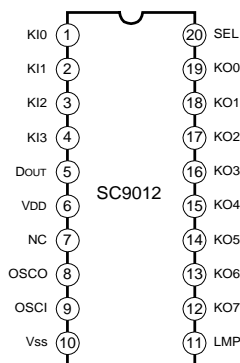

BLOCK DIAGRAM

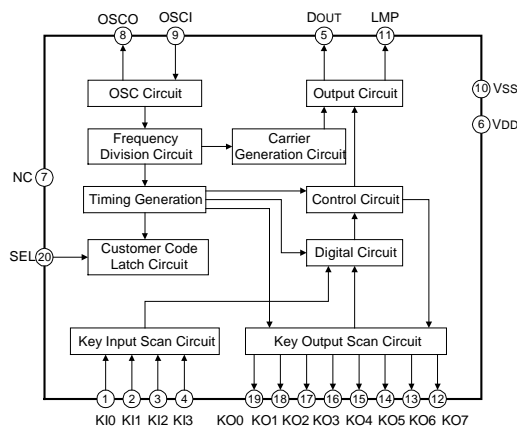

ABSOLUTE MAXIMUM RATING (Tamb=>25°C)

Characteristic	Symbol	Value	Unit
Supply Voltage	V _{DD}	-0.3 ~ 5.0	V
Input Voltage With Respect To V _{SS}	V _{IN}	V _{SS} -0.3 ~ V _{DD} +0.3	V
Output Current	I _{OUT(REQ)}	-20	mA
Power Dissipation	P _d	300	mW
Storage Temperature	T _{stg}	-40 ~ +125	°C
Operating Temperature	T _{OPR}	-20 ~ +75	°C

ELECTRICAL CHARACTERISTICS (Tamb=25°C, V_{DD}=3V)

Parameter	Symbol	Test conditions	Min	Typ	Max	Unit
Operating supply Voltage	V _{DD}	All Function Operating	2.0	--	4.0	V
Operating Supply Current	I _{DD}	f _{osc} =455 kHz	--	--	1	mA
Stand-By Current	I _{SB}	All Keys Off Stops. Oscillation Output Floating.			1	μA
Output High Level Current (Dout)	I _{OH}	V _{OH} =1.5V, V _{DD} =3V	-10	--	--	mA
Output Low Level Current (LMP)	I _{OL}	V _{OL} =1.5V, V _{DD} =3V	5	--	--	mA
Input High Level Voltage (KI)	V _{IH}	V _{DD} =3V	0.7 V _{DD}		V _{DD}	V
Input Low Level Voltage (KI)	V _{IL}	V _{DD} =3V	0		0.3 V _{DD}	V
Oscillation Frequency	f _{osc}	--	400	455	600	kHz
Input Pull-down Resistor (KI)	R _{ON}	V _{DD} =3V	100	300	500	kΩ

PIN DESCRIPTION

Pin No.	Symbol	I/O	Description
1~4	KI0~KI3	I	Key Scan Input Pins. Each pin has a built-in pull-down resistor
5	DOUT	O	Infrared LED Driving Output Pin
6	V _{DD}	--	Positive Power Supply
7	NC	--	No Connection. (When used, Suggest to connected with V _{DD})
8	OSCO	O	Oscillator Output Pin
9	OSCI	I	Oscillator Input Pin
10	V _{SS}	--	Negative Power Supply
11	LMP	O	LED Display Output Pin
12~19	KO0~KO8	O	Key Scan Output Pins
20	SEL	I	Custom Code Selection Pin

FUNCTIONAL DESCRIPTION

1. OSCILLATION CIRCUIT

An oscillator circuit may be constructed by connecting a 480kHz or 455kHz Crystal Resonator and two capacitors between OSCO and OSCI. Please refer to the follow diagram. Unless the keys are being operated, the oscillation is normally stopped. Thus, power consumption is considerably reduced.

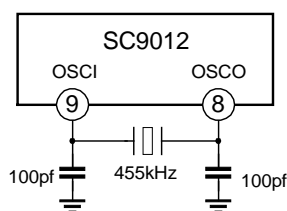

2. OSCILLATION FREQUENCY

The oscillator frequency is 455kHz, passed by a 12 division frequency circuit, can get a 37.9 ~ 39.2 frequency; 1/3 duty carrier. In addition, The oscillator frequency divided by 256, can get the basic system work time (1.78kHz). The relation of carrier frequency (fc), internal work time period (Tm) and oscillator frequency (fosc) is given below:

$$fc = (1/12) \times fosc \quad (\text{duty: } 1/3) ;$$

$$Tm = 256 / fosc. \quad (\text{Tm: the width of a high level pulse}) .$$

3. KEY MATRIX

Key Inputs -- KI0~KI3 of SC9012 have built-in pull-down resistors, which combined 32 keys matrix with Key Outputs --KO0~KO7. Except the stated 6 double keys, Pressing other keys that are NOT intended for the double key operation do NOT generate any output. Please refer to the follow diagram for the keys input matrix of SC9012.

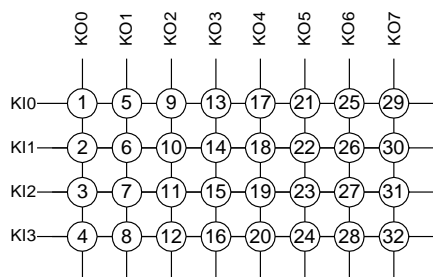

4. CUSTOMER CODE

There are 8 customer codes, can be selected by using the SEL pin connected with any pin of “KO0 ~ KO7”. Please refer to follow diagram:

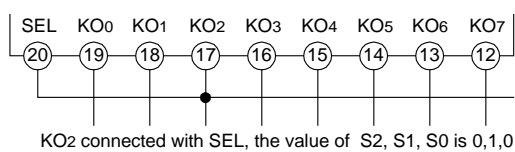

Connected with SEL	System Code (S2 S1 S0)		
KO0	0	0	0
KO1	0	0	1
KO2	0	1	0
KO3	0	1	1
KO4	1	0	0
KO5	1	0	1
KO6	1	1	0
KO7	1	1	1

The Custom Code consists of 8 bits :

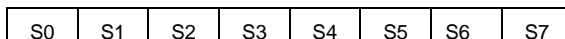

Among these, S0, S1, S2 can be selected with SEL Pin and any pin of “KO0 ~ KO7”; Bit S3 has a fixed value of “1”; Bits S4 ~ S7 have a fixed value of “0”.

5. TRANSMISSION CODE

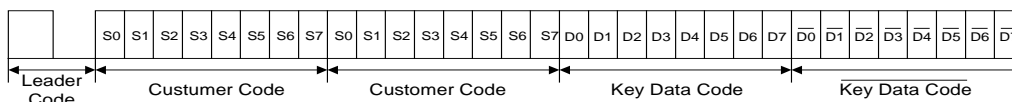

Refer to the above diagram, the transmission code consists of leader code, customer code, and key data code.; The leader code consists of a 4.5 ms carrier waveform followed by a 4.5 ms OFF waveform. The 8-bits customer code transmitted two times; The 8-bits key data code transmitted two times also, first is the origin code; second is the inverse code.

The code uses the PPM (Pulse Position Modulation) Method, with “0”and “1” differentiated by the time between pulses.

The waveforms of leader code, bit "0" and bit "1" refer to follow diagram:

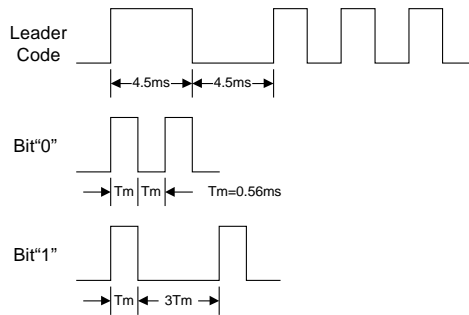

6. DOUBLE KEY OPERATION

There are 6 double keys operation, such as K21 connected with K22 ~ K24; K25 connected with K26 ~ K28, refer to the follow table:

The Primary Key	The Secondary Key	D0	D1	D2	D3	D4	D5	D6	D7
K21	K22	1	0	1	0	1	1	0	0
	K23	0	1	1	0	1	1	0	0
	K24	1	1	1	0	1	1	0	0
K25	K26	1	0	0	1	1	1	0	0
	K27	0	1	0	1	1	1	0	0
	K28	1	1	0	1	1	1	0	0

When any of the double or multiple key combinations are pressed, except the 6 keys mentioned above, there is no output.

In addition, Double Key Operation is useful for tape deck recording operation. Press the K21 or K23 key at the first then followed by the secondary key such as K22~K24; K26~K28.

Please refer to the follow diagram:

1. Double Key Operation available

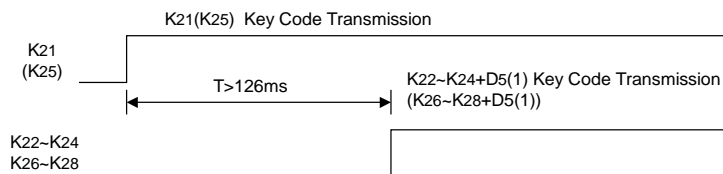

2. Double Key Operation disable

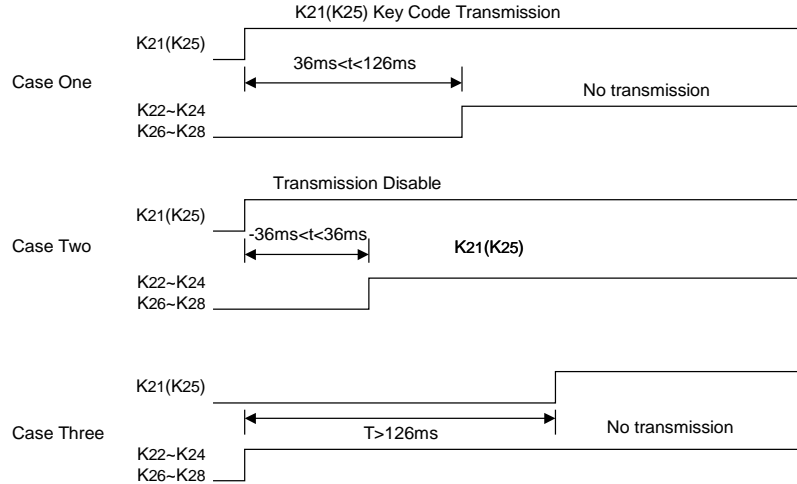

7. REMOTE OUTPUT WAVEFORMS

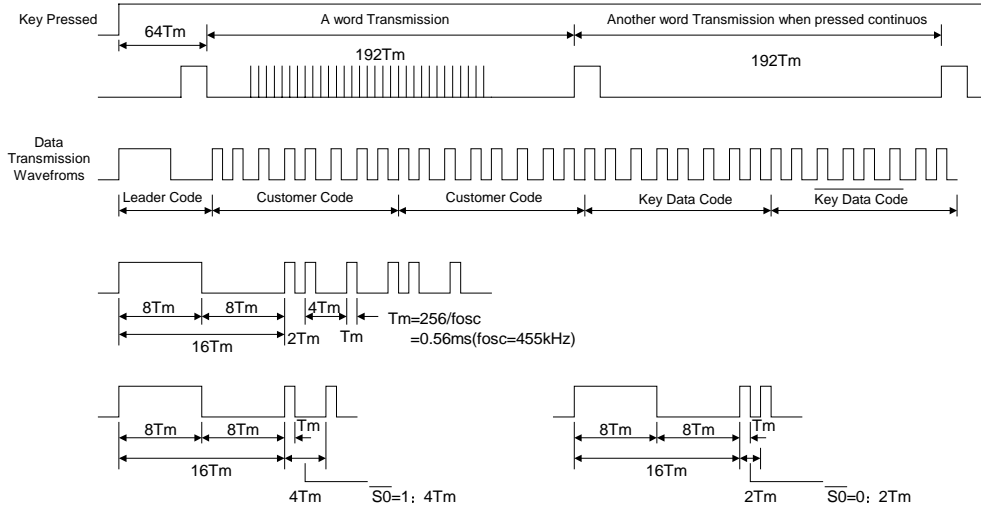

8. SC9012 DATA CODE

The Keys Data Code is given in the table below.

Key No.	Connection				KI/O	Data Code							
	K0	K1	K2	K3		D0	D1	D2	D3	D4	D5	D6	D7
K1	•				KO0	0	0	0	0	0	0	0	0
K2		•				1	0	0	0	0	0	0	0
K3			•			0	1	0	0	0	0	0	0
K4				•		1	1	0	0	0	0	0	0
K5	•				KO1	0	0	1	0	0	0	0	0
K6		•				1	0	1	0	0	0	0	0
K7			•			0	1	1	0	0	0	0	0
K8				•		1	1	1	0	0	0	0	0
K9	•				KO2	0	0	0	1	0	0	0	0
K10		•				1	0	0	1	0	0	0	0
K11			•			0	1	0	1	0	0	0	0
K12				•		1	1	0	1	0	0	0	0
K13	•				KO3	0	0	1	1	0	0	0	0
K14		•				1	0	1	1	0	0	0	0
K15			•			0	1	1	1	0	0	0	0
K16				•		1	1	1	1	0	0	0	0
K17	•				KO4	0	0	0	0	1	0	0	0
K18		•				1	0	0	0	1	0	0	0
K19			•			0	1	0	0	1	0	0	0
K20				•		1	1	0	0	1	0	0	0
K21	•				KO5	0	0	1	0	1	0	0	0
K22		•				1	0	1	0	1	0	0	0
K23			•			0	1	1	0	1	0	0	0
K24				•		1	1	1	0	1	0	0	0
K25	•				KO6	0	0	0	1	1	0	0	0
K26		•				1	0	0	1	1	0	0	0
K27			•			0	1	0	1	1	0	0	0
K28				•		1	1	0	1	1	0	0	0
K29	•				KO7	0	0	1	1	1	0	0	0
K30		•				1	0	1	1	1	0	0	0
K31			•			0	1	1	1	1	0	0	0
K32				•		1	1	1	1	1	0	0	0

TYPICAL APPLICATION CIRCUIT

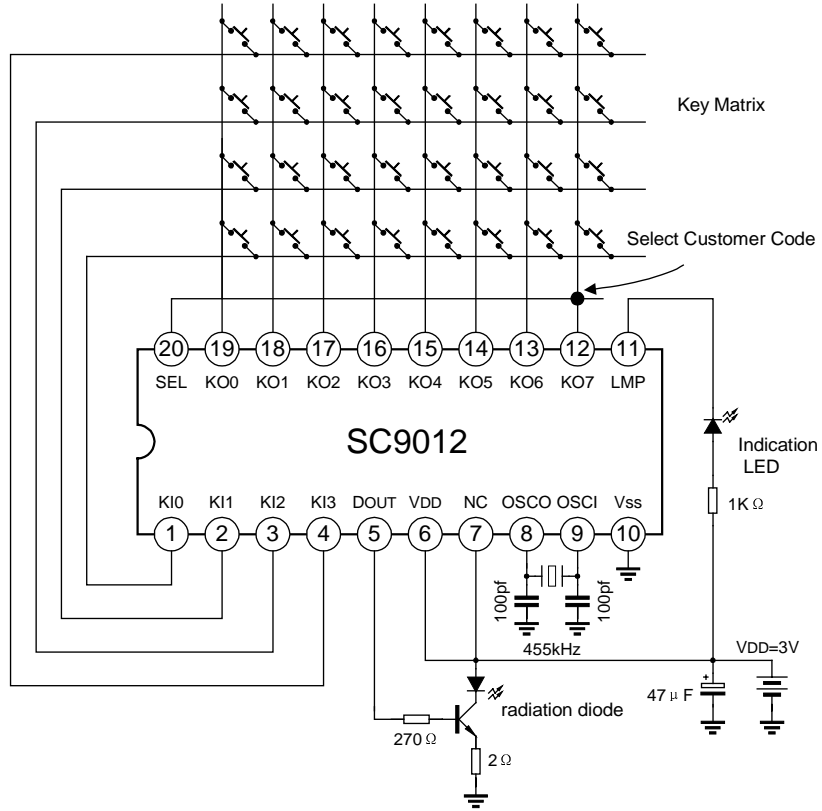

CHIP TOPOGRAPHY

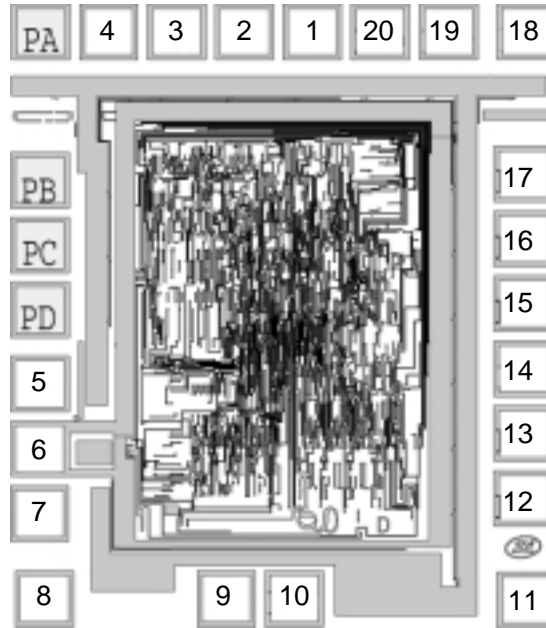

Size: 1.25 x 1.47 mm²

PAD COORDINATES (Unit: μm)

No.	Symbol	X	Y	No.	Symbol	X	Y
1	P1	-2.5	550.2	11	P11	438.6	-674.0
2	P2	-142.3	550.2	12	P12	432.7	-455.3
3	P3	-282.1	550.2	13	P13	432.7	-315.2
4	P4	-422.4	550.2	14	P14	432.7	-175.6
5	P5	-564.0	-208.0	15	P15	432.7	-35.7
6	P6	-564.0	-348.0	16	P16	432.7	107.7
7	P7	-564.0	-488.3	17	P17	432.7	243.8
8	P8	-554.7	-671.2	18	P18	438.9	550.2
9	P9	-178.8	-671.2	19	P19	278.7	550.2
10	P10	-39.9	-671.2	20	P20	137.4	550.2

Note: The original point of the coordinate is the die center.

PCB WIRE LAYOUT SCHEMATIC:

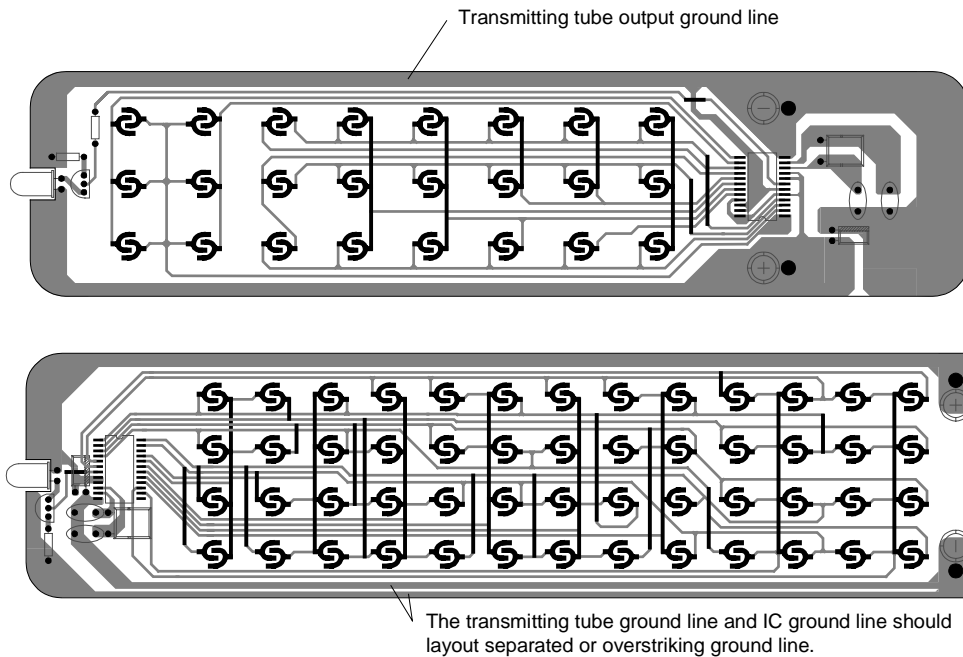

The above IC only use to hint, not to specified.

Note: :

- * In wire layout, the power filter capacitor should near to IC.
- * In wire layout, should avoid power line and ground line too long.
- * Recommended infrared transmit unit and IC ground line should layout separated, or overstriking lines.
- * The emitter of triode connect $1\ \Omega$ resistor at least.
- * Recommended triode use 9014.

PACKAGE OUTLINE

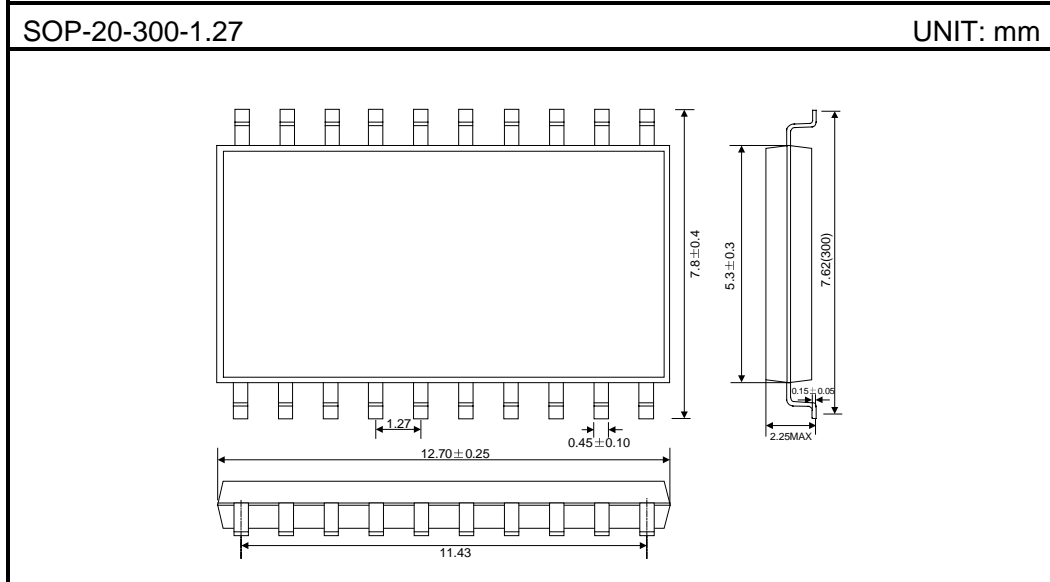

Attach

Revision History

Data	REV	Description	Page
2001.11.12	2.0		
2002.02.28	2.1	Add the "Ordering information"	1
		Modify the "Typical application circuit"	8
		Add the "PCB wire layout schematic"	10
		Modify the "Package outline"	11