

JOBAN Confidential		
Rev:	1.0	Rev. 1.0
Date:	2023-10-27	Date:
By:	Joban	By:
Checked By:	Joban	Checked By:
Approved By:	Joban	Approved By:

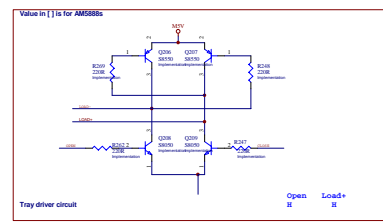

Rev: **JORGAN Confidential**

Rev	Number	Revision
1	1.0	Initial Release
2	1.1	Update BOM
3	1.2	Update Schematic
4	1.3	Final Release

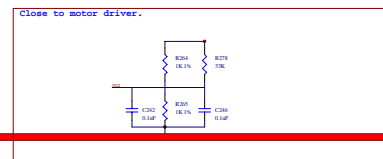
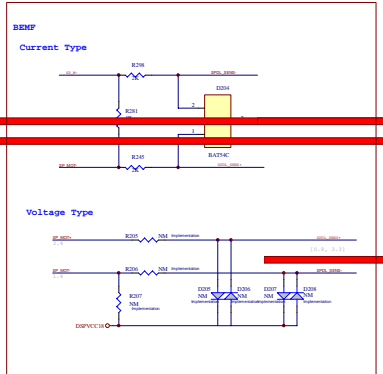
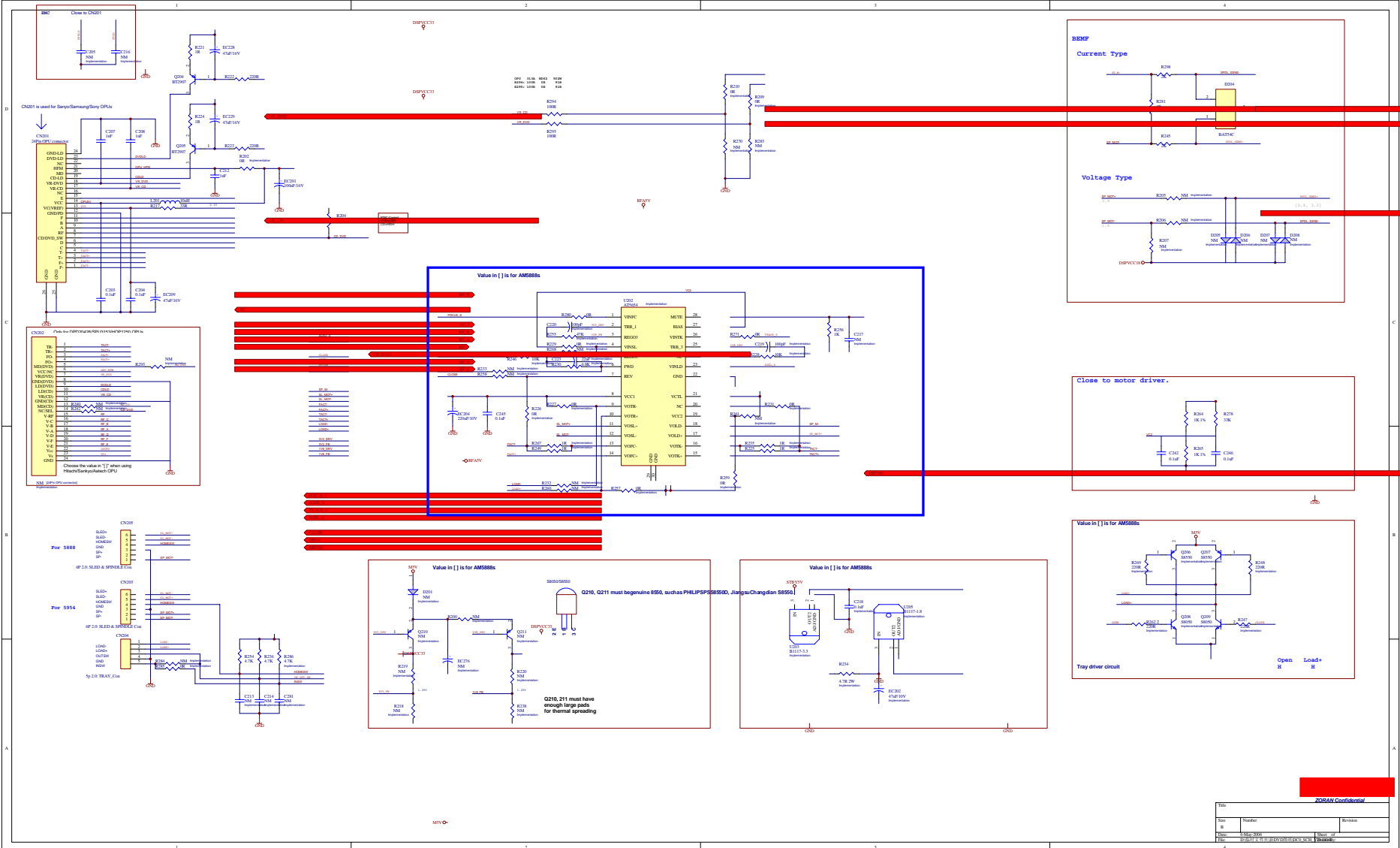
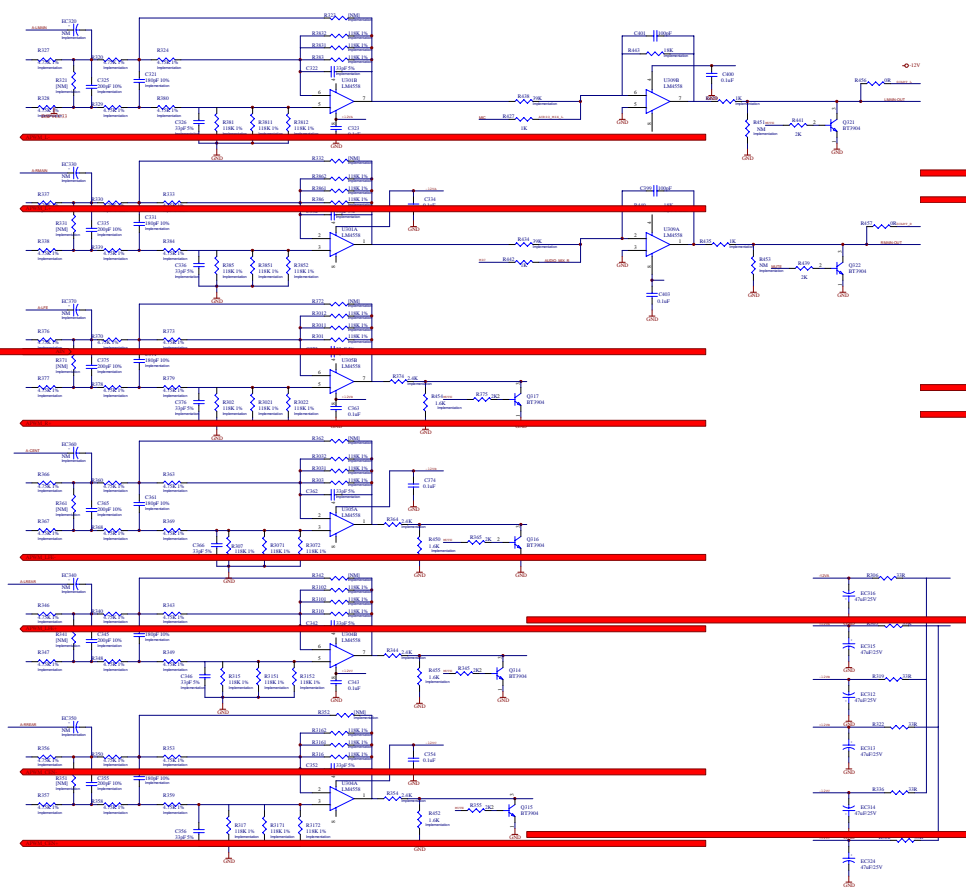
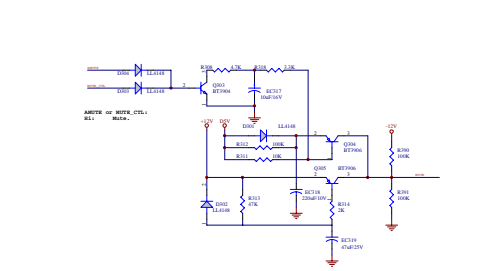
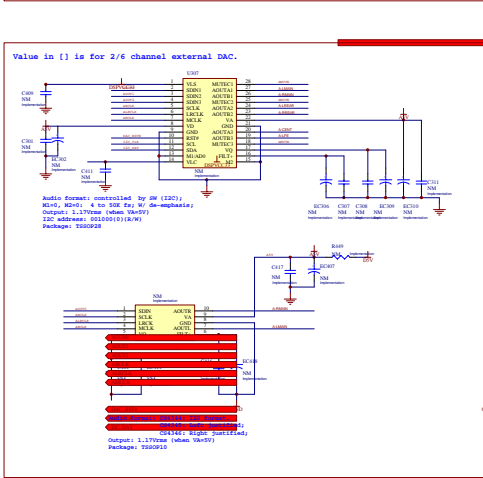
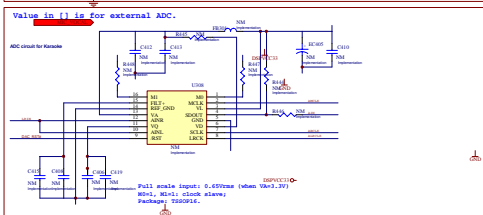
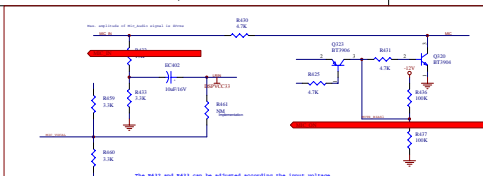

JDRAN Confidential

Rev	Number	Revision

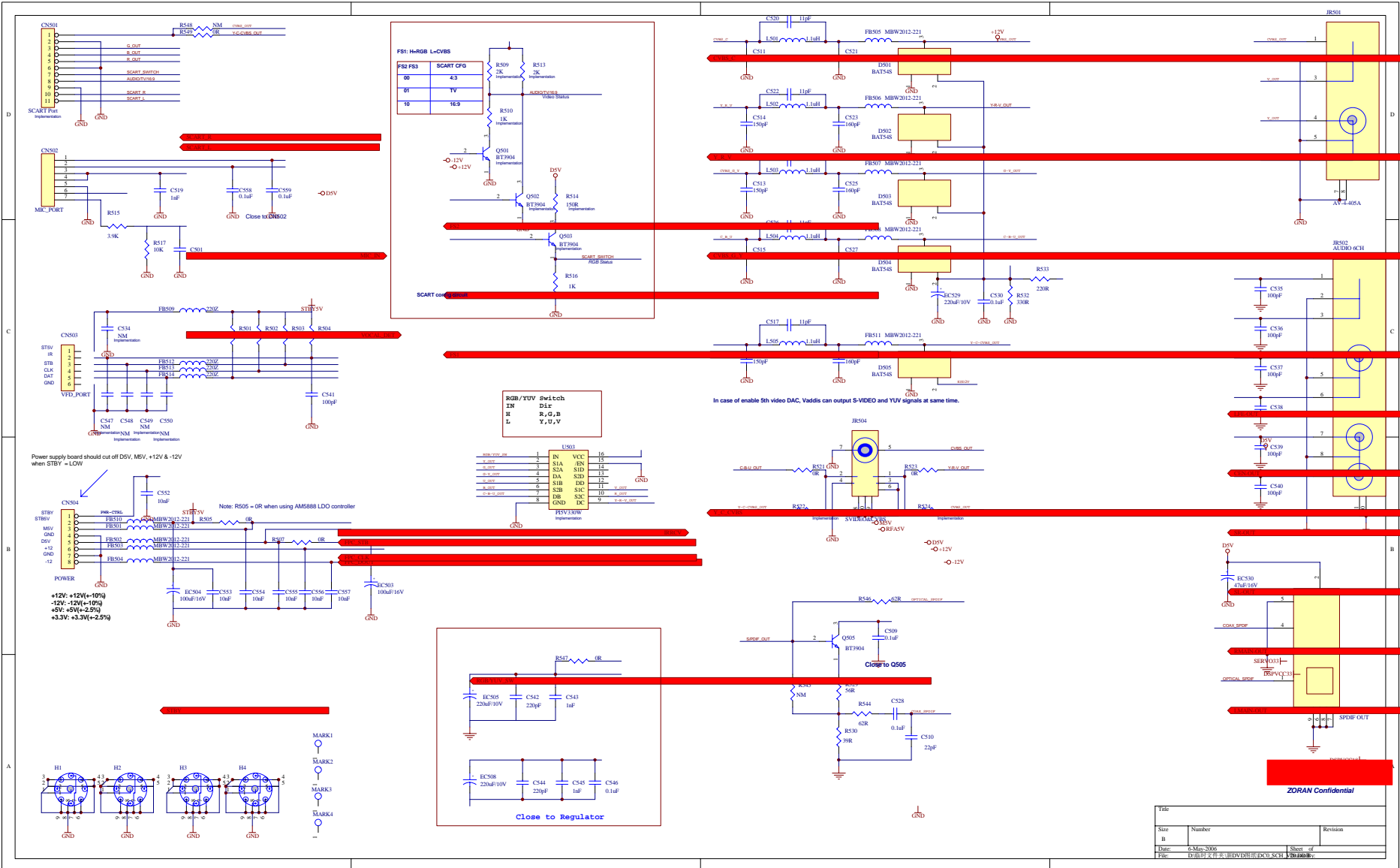

ZORAN Confidential

Title			
Size	Number	Revision	
B			
Issue	C-Mex-3000	Sheet of	
File	D:\BUP\2\F1\REV\DR\DCO_SCH_101000		

3---Audio_Input_Output

SR-OUT	SR-OUT	MIC_IN	MIC_IN
SL-OUT	SL-OUT	MIC_ON	MIC_ON
APWM_L-	APWM_L-	LMAIN-OUT	LMAIN-OUT
APWM_L+	APWM_L+	RMAIN-OUT	RMAIN-OUT
CEN-OUT	CEN-OUT	AIN	AIN
MUTE_CTL	MUTE_CTL	ALRCLK	ALRCLK
APWM_SR-	APWM_SR-	ABCLK	ABCLK
APWM_SR+	APWM_SR+	AMCLK	AMCLK
APWM_SL-	APWM_SL-	AOUT2	AOUT2
APWM_SL+	APWM_SL+	AOUT1	AOUT1
APWM_CEN	APWM_CEN-	AOUT0	AOUT0
APWM_CEN	APWM_CEN+	DAC_RST#	DAC_RST#
APWM_LFE-	APWM_LFE-	I2C_CLK	I2C_CLK
APWM_LFE+	APWM_LFE+	I2C_DAT	I2C_DAT
APWM_R-	APWM_R-	SCART_L	SCART_L
APWM_R+	APWM_R+	SCART_R	SCART_R
LFE-OUT	LFE-OUT	MIC_VOCAL	MIC_VOCAL

2---FE_Regulator

RF_A	RF_A	HOMESW	HOMESW
RF_B	RF_B	FOCUS_S	FOCUS_S
RF_C	RF_C	SLED_S	SLED_S
RF_D	RF_D	TRACK_S	TRACK_S
RF	RF	SPDL_S	SPDL_S
RF_F	RF_F	CLOSE	CLOSE
RF_E	RF_E	OPEN	OPEN
LD_DVD	LD_DVD	DRVSB	DRVSB
LD_CD	LD_CD	SPDL_SENS+	SPDL_SENS+
VC	VC	SPDL_SENS-	SPDL_SENS-
CD_DVD	CD_DVD	INSW	INSW
MD_CD	MD_CD	CLOSE	CLOSE
MD_DVD	MD_DVD	OPEN	OPEN
IN_OUT_SW	IN_OUT_SW	DRVSB	DRVSB

4---Power_Video_Out_Conn

VOCAL_DET	VOCAL_DET	RMAIN-OUT	RMAIN-OUT
MIC_IN	MIC_IN	LMAIN-OUT	LMAIN-OUT
C_B_U	C_B_U	SR-OUT	SR-OUT
FPC_DOUT	FPC_DOUT	SL-OUT	SL-OUT
CEN-OUT	CEN-OUT	LFE-OUT	LFE-OUT
CVBS_C	CVBS_C	S/PDIF_OUT	S/PDIF_OUT
FS1	FS1	Y_C_CVBS	Y_C_CVBS
FPC_CLK	FPC_CLK	STBY	STBY
FPC_STB	FPC_STB	FS3	FS3
IRRCV	IRRCV	FS2	FS2
Y_R_V	Y_R_V	RGB/YUV_SW	RGB/YUV_SW
CVBS_G_Y	CVBS_G_Y	SCART_L	SCART_L
		SCART_R	SCART_R

4---Power_Video_Out_Conn

ECO

ECO

0---Version Document

0---Version Document

1---Vaddis_SDRAM_Flash

FPC_DOUT	FPC_DOUT	FS2	FS2
FPC_CLK	FPC_CLK	FS1	FS1
FPC_STB	FPC_STB	I2C_CLK	I2C_CLK
C_B_U	C_B_U	I2C_DAT	I2C_DAT
Y_R_V	Y_R_V	AOUT1	AOUT1
CVBS_C	CVBS_C	AOUT2	AOUT2
CVBS_G_Y	CVBS_G_Y	STBY	STBY
Y_C_CVBS	Y_C_CVBS	CD_DVD	CD_DVD
ABCLK	ABCLK	IRRCV	IRRCV
ALRCLK	ALRCLK	AOUT0	AOUT0
AMCLK	AMCLK	AIN	AIN
APWM_LFE-	APWM_LFE+	VOCAL_DET	VOCAL_DET
APWM_LFE+	APWM_LFE-	APWM_R+	APWM_R+
FOCUS_S	FOCUS_S	APWM_L-	APWM_L-
TRACK_S	TRACK_S	APWM_SL-	APWM_SL-
SPDL_S	SPDL_S	APWM_L+	APWM_L+
SLED_S	SLED_S	APWM_SL+	APWM_SL+
MD_DVD	MD_DVD	APWM_R-	APWM_R-
MD_CD	MD_CD	APWM_CEN-	APWM_CEN-
RF_F	RF_F	MIC_ON	MIC_ON
SPDL_SENS-	SPDL_SENS+	DRVSB	DRVSB
RF_E	RF_E	APWM_CEN+	APWM_CEN+
SPDL_SENS+	SPDL_SENS-	APWM_SR-	APWM_SR-
RF_B	RF_B	IN_OUT_SW	IN_OUT_SW
RF_A	RF_A	OPEN	OPEN
RF_D	RF_D	APWM_SR+	APWM_SR+
RF_C	RF_C	S/PDIF_OUT	S/PDIF_OUT
VC	VC	HOMESW	HOMESW
LD_CD	LD_CD	CLOSE	CLOSE
LD_DVD	LD_DVD	RGB/YUV_SW	RGB/YUV_SW
RF	RF	INSW	INSW
MIC_VOCAL	MIC_VOCAL	MUTE_CTL	MUTE_CTL
FS3	FS3	DAC_RST#	DAC_RST#

1---Vaddis_SDRAM_Flash

Title		
Size	Number	Revision
B		
Date:	6-May-2006	Sheet of
File:	D:\临时文件夹\新DVD图纸\DCO_SCH	V1.0\By: