

RM-17 schematic diagrams

Table of Contents	Page No
DCT-4 common baseband	2
System connector, audio	3
UEME, SIM	4
UPP, combo memory	5
FM radio, camera	6
UI, vibra, keyboard	7
RF part	8
Signal overview	9
Component finder	10

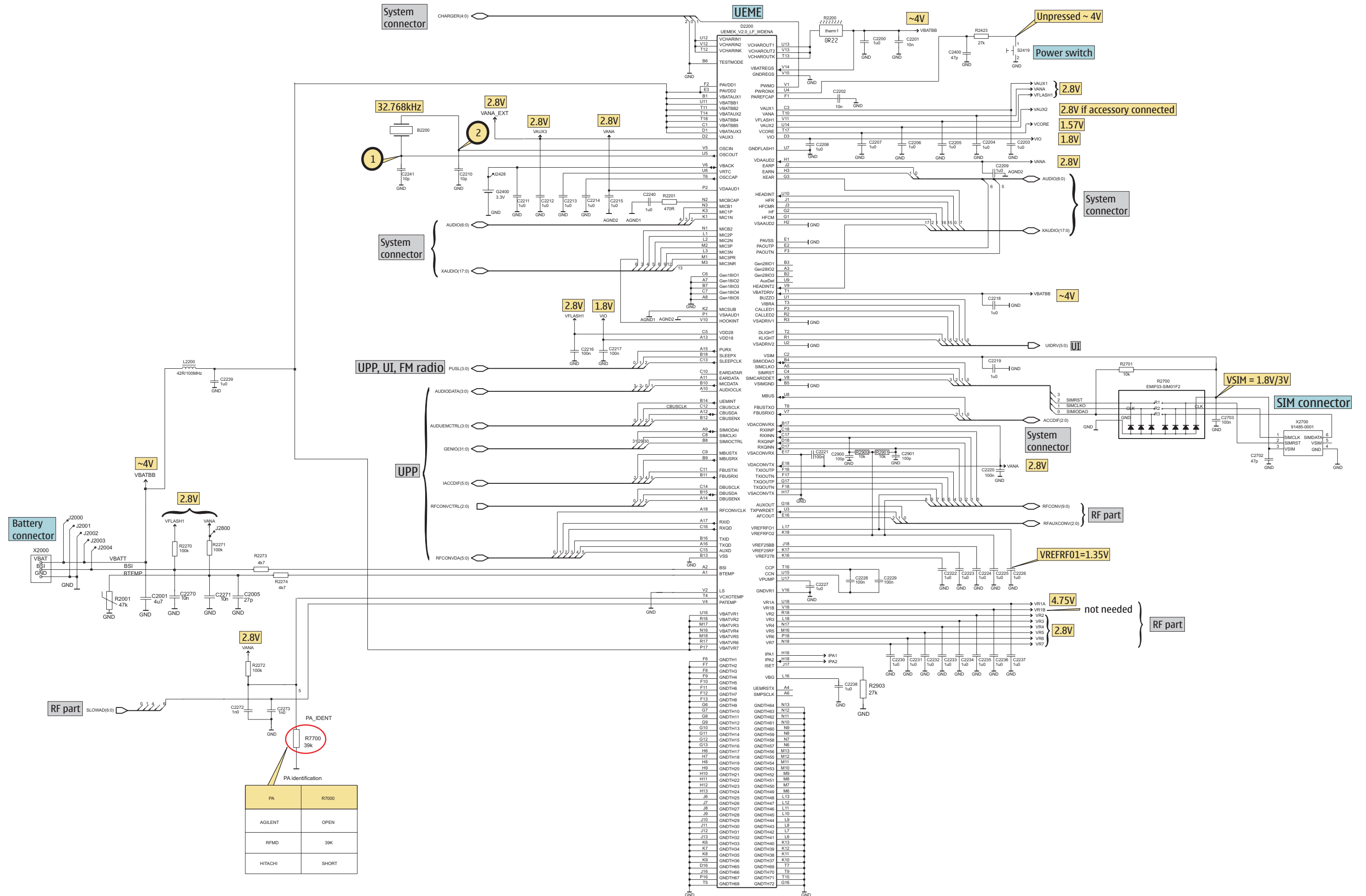

UPP, combo memory

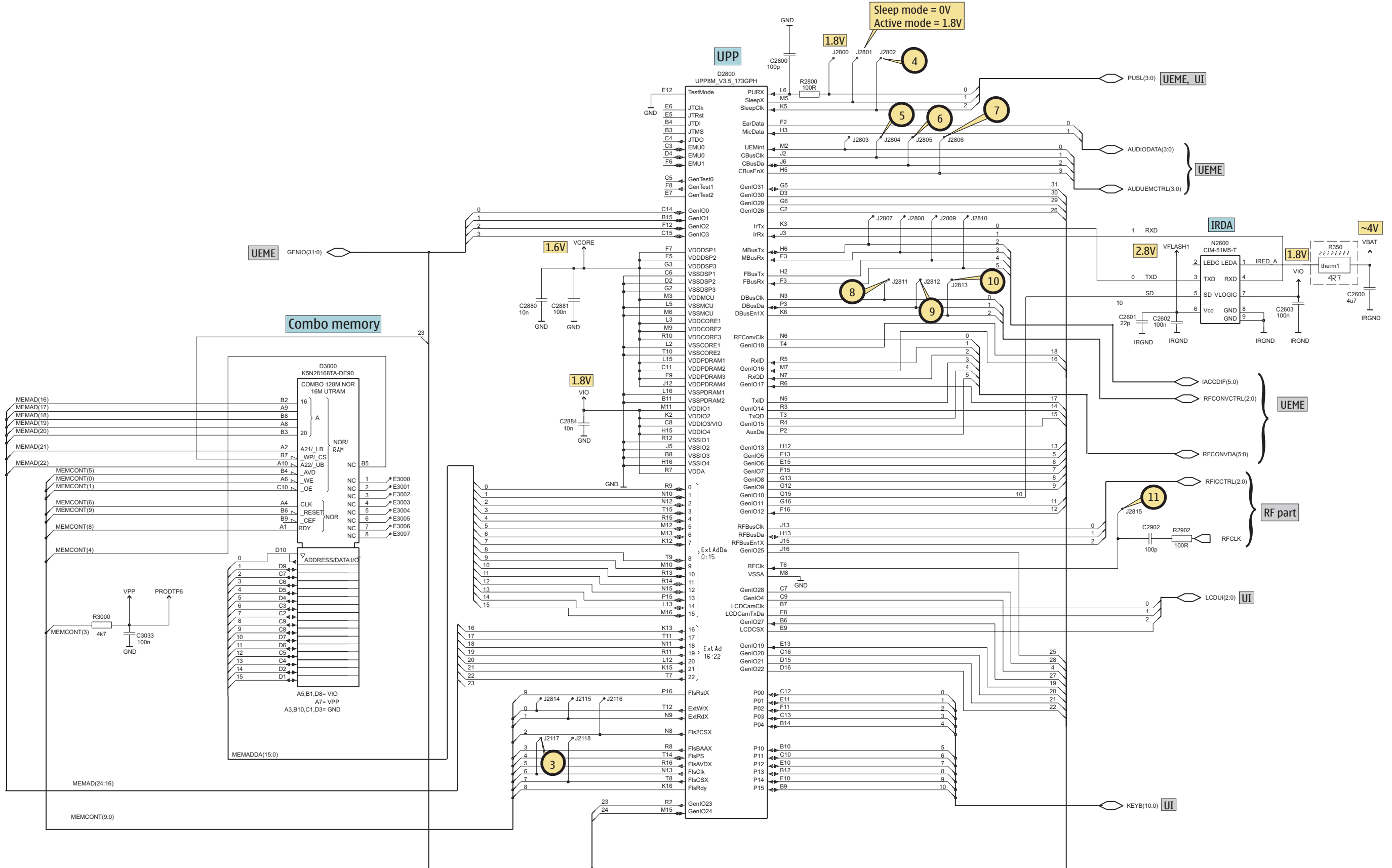

FM radio, camera

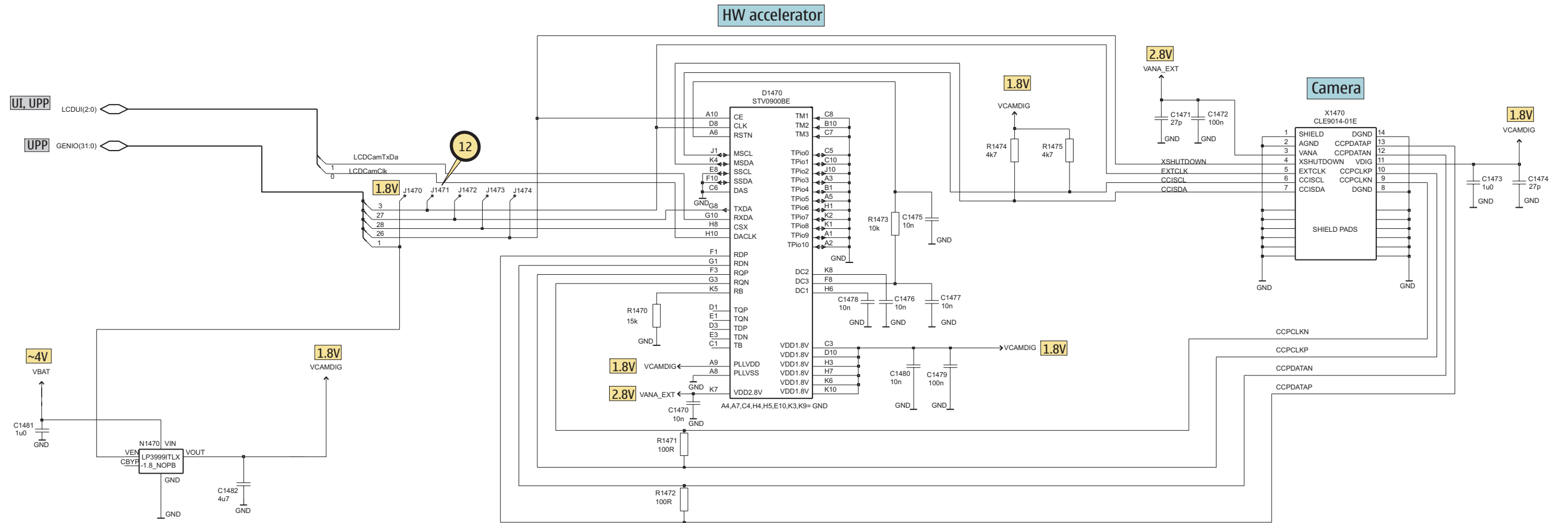
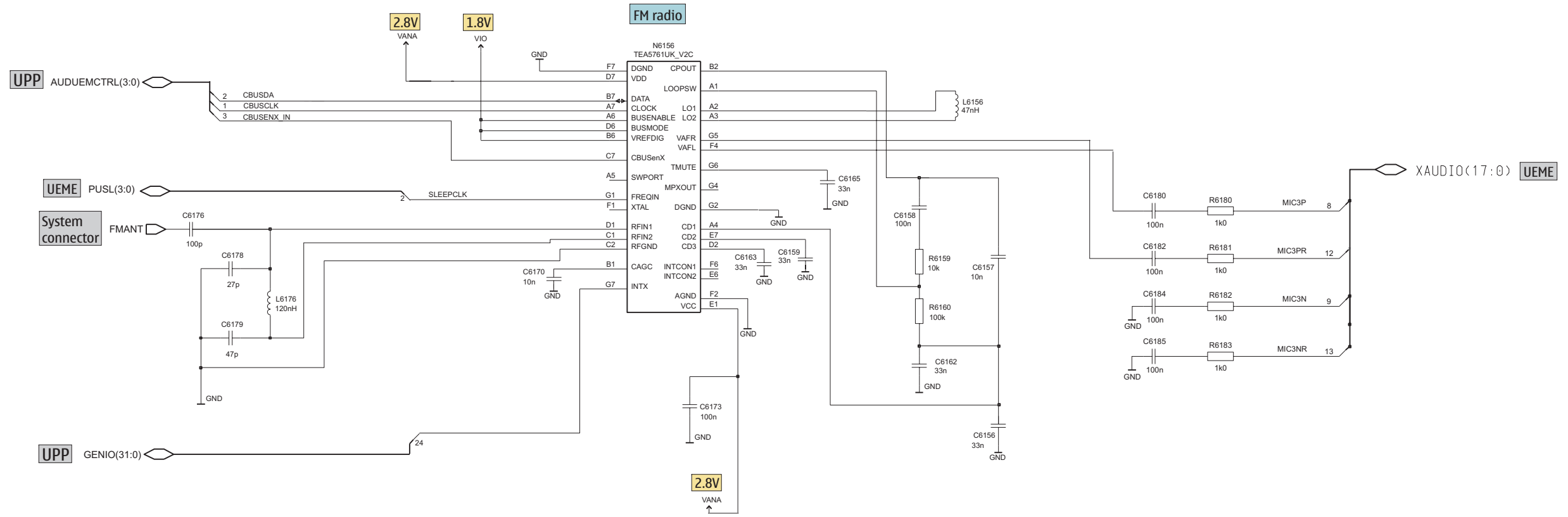

UI, vibra, keyboard

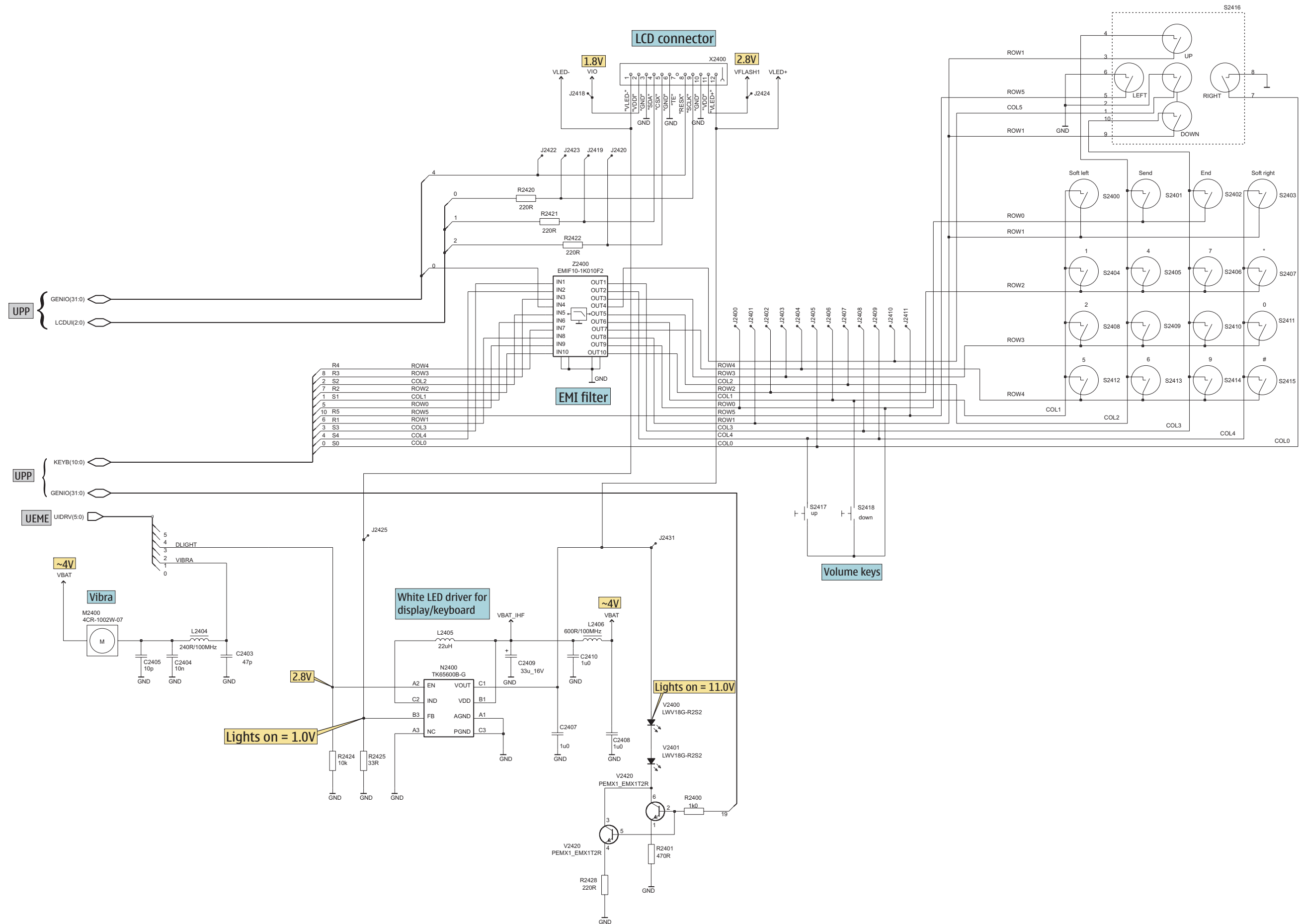

RF part

VANT_2 VC1 [Volt]	VANT_3 VC2 [Volt]	VANT_1 VC3 [Volt]	RX 1 GSM900 RX	RX 2 GSM1800 RX	RX 3 GSM1900 RX	TX 1 GSM900 TX	TX 2 GSM1800/1900 TX
0	0	0	X				
0	0	0		X			
0	2.6	2.6				X	
0	2.6	0			X		
2.6	2.6	0					X

Band	Channel	RX	VCO/RX	VC/RX	TX	VCO/TX	VC/TX
EGSM 900	37	942,4MHz	3769,6MHz	~2,73V	897,4MHz	3589,6MHz	~1,99V
GSM 1800	700	1842,8MHz	3685,6MHz	~2,39V	1747,8MHz	3495,6MHz	~1,60V
GSM 1900	661	1960,0MHz	3920,0MHz	~3,31V	1880,0MHz	3760,0MHz	~2,96V

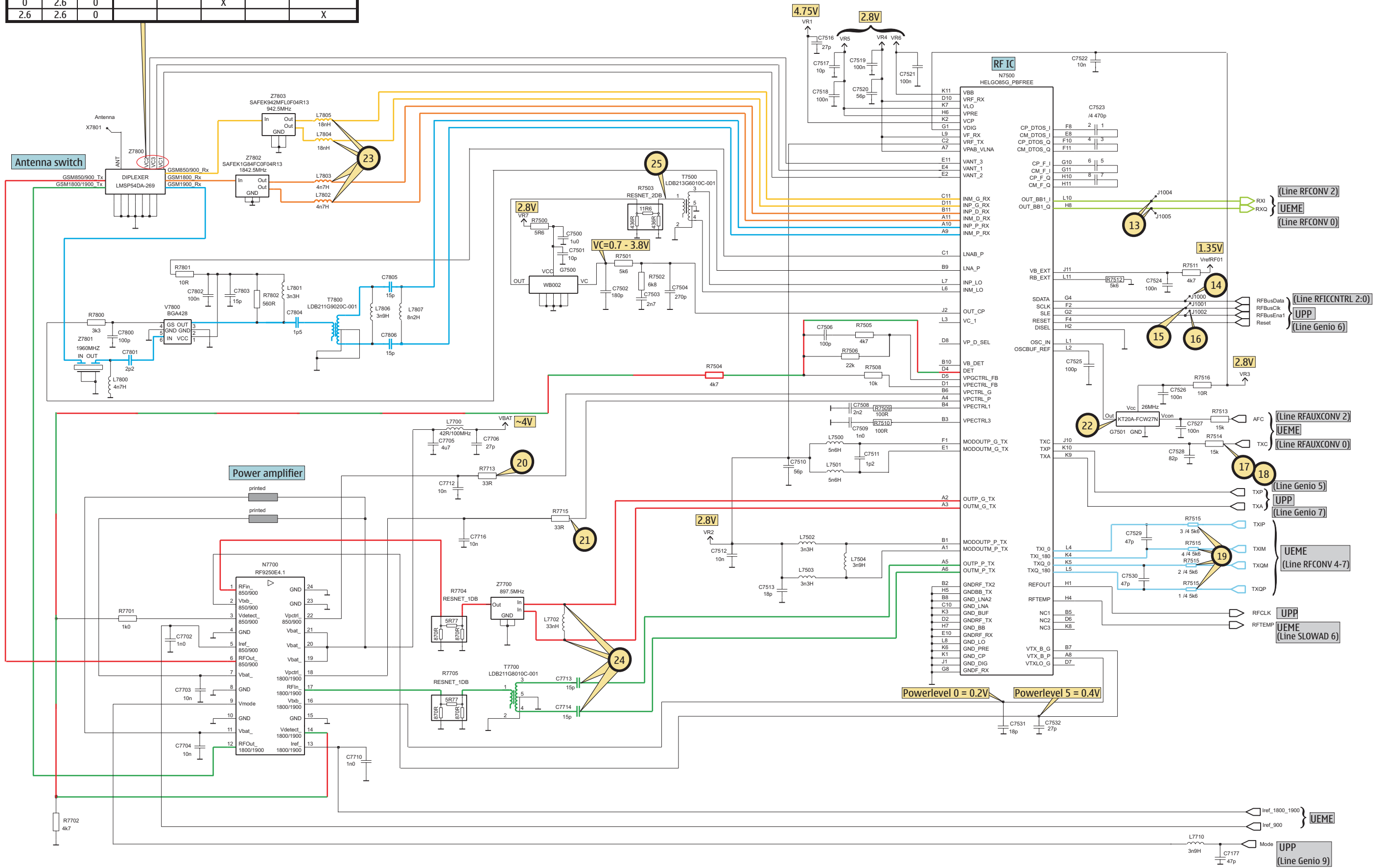

Signal overview

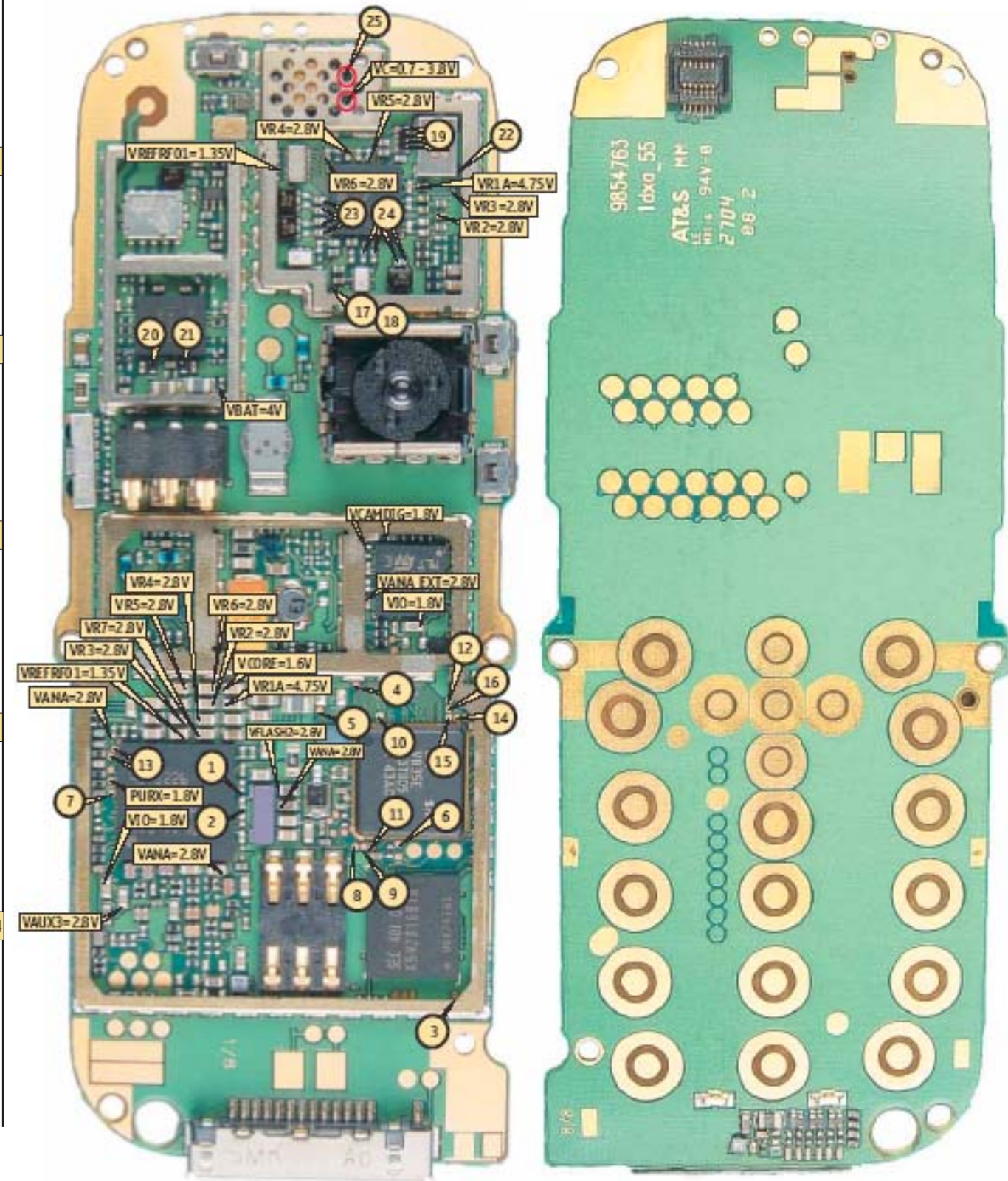
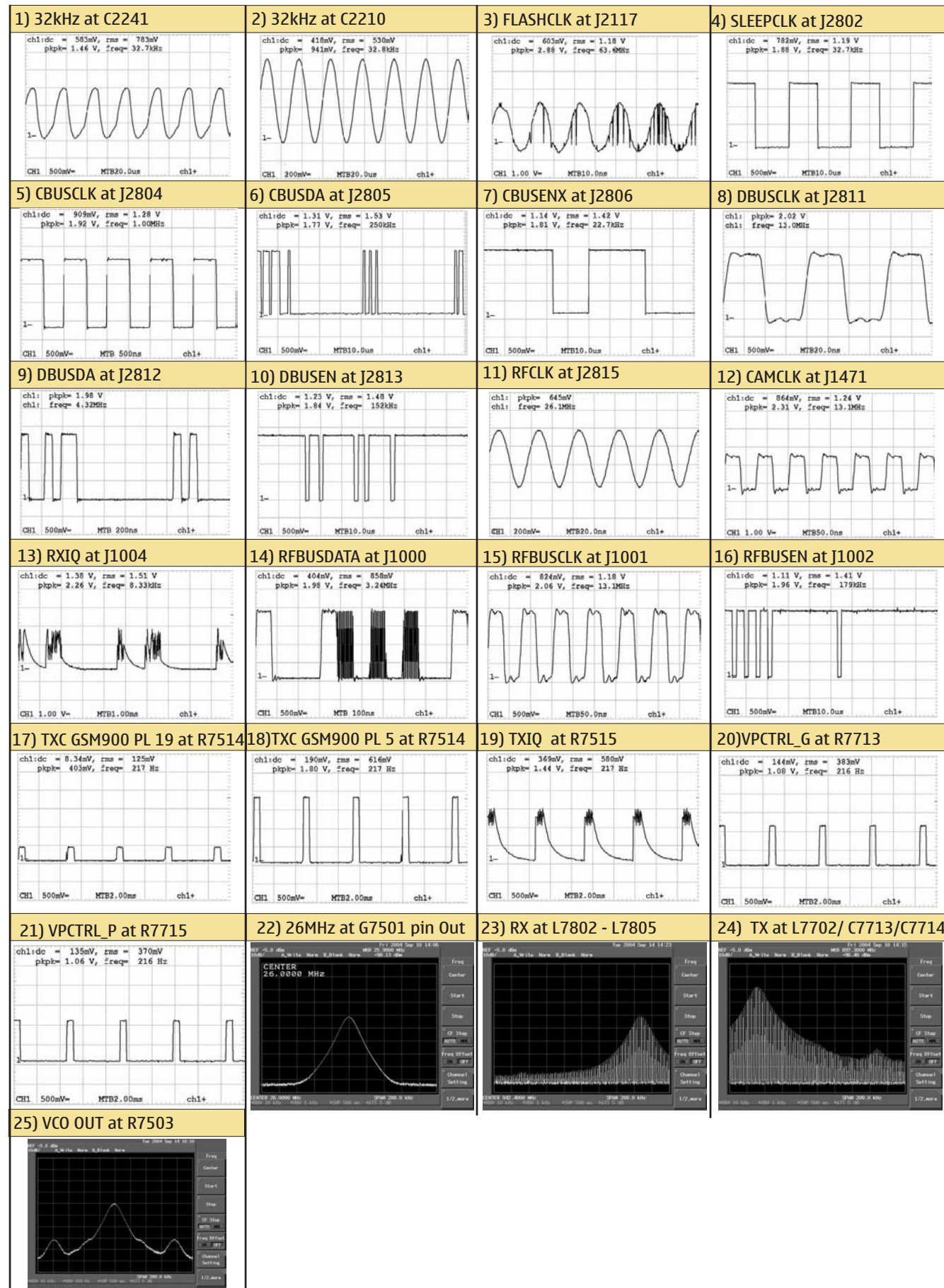

Component finder

B	C2203	P2	C2882	N8	C7706	G4	J2117	R8	L2150	B4	R2154	P3	R7514	F6	
B2200	05	C2204	05	C2884	N6	C7707	F2	J2118	R7	L2153	Q3	R2155	J6	R7515	C7
B2400	B4	C2205	N5	C2885	N8	C7708	G3	J2400	I5	L2154	G5	R2156	Q3	R7516	D8
B2401	F4	C2206	N5	C2900	N2	C7709	G4	J2401	I5	L2155	G5	R2158	Q4	R7517	E8
B2402	S5	C2207	M4	C2901	M2	C7710	F4	J2402	I6	L2200	M5	R2159	Q4	R7700	N2
C	C2208	P2	C2902	N8	C7711	F2	J2403	I6	L2404	Q2	R2160	Q3	R7701	F2	
C1470	K6	C2209	P3	C3030	R7	C7712	G2	J2404	I6	L2405	K5	R2162	Q4	R7702	F4
C1471	K6	C2210	O4	C3031	R6	C7713	E6	J2405	I6	L2406	J4	R2163	J5	R7704	G2
C1472	K6	C2211	O5	C3033	O7	C7714	E6	J2406	I7	L6156	J3	R2164	J5	R7705	G4
C1473	J6	C2212	P2	C3180	O8	C7715	E6	J2407	I7	L6176	J2	R2171	Q4	R7712	G2
C1474	J7	C2213	O5	C6156	J3	C7716	G3	J2408	I7	L7500	D7	R2172	P4	R7713	G3
C1475	J8	C2214	O5	C6157	J3	C7717	F4	J2409	I7	L7501	D7	R2173	P4	R7715	G3
C1476	K6	C2215	P4	C6158	J3	C7718	F2	J2410	I8	L7502	E7	R2174	P4	R7716	G3
C1477	K7	C2216	O2	C6159	K3	C7719	F2	J2411	I8	L7503	E7	R2175	P2	R7800	C4
C1478	J6	C2217	N2	C6162	J3	C7720	E4	J2418	G8	L7504	E7	R2176	P3	R7801	E3
C1479	K8	C2218	P4	C6163	L3	C7721	F4	J2419	G7	L7700	G3	R2200	N5	R7802	E4
C1480	K8	C2219	Q4	C6164	K3	C7722	G3	J2420	H6	L7701	G2	R2201	P3	S	
C1481	L8	C2220	M2	C6165	L3	C7800	D4	J2421	H6	L7702	E7	R2270	O2	S2417	G8
C1482	K7	C2221	M2	C6167	J3	C7801	D3	J2422	G7	L7704	F2	R2271	N2	S2418	I8
C1483	L7	C2222	M3	C6170	J2	C7802	D3	J2423	G6	L7705	E3	R2272	N2	S2419	B4
C2001	M5	C2223	M3	C6173	L2	C7803	D4	J2424	H7	L7710	G2	R2273	O2	T	
C2002	H2	C2224	M3	C6176	K2	C7804	E4	J2425	H7	L7800	C3	R2274	P2	T7500	C6
C2004	I2	C2225	M2	C6178	K2	C7805	E6	J2426	B4	L7801	E4	R2400	L6	T7700	F6
C2005	O6	C2226	M3	C6179	K2	C7806	E5	J2427	B4	L7802	E5	R2401	L5	T7800	E5
C2006	T5	C2227	M4	C6180	L3	C7807	E5	J2428	I5	L7803	E5	R2420	L7	V	
C2007	N4	C2228	N4	C6182	L3	C7808	D5	J2429	S5	L7804	D5	R2421	K7	V2000	N6
C2008	T5	C2229	N4	C6184	P3	D	J2430	S6	L7805	D5	R2422	L7	V2400	T4	
C2009	Q2	C2230	M4	C6185	Q4	D1470	K7	J2431	H8	L7806	E5	R2423	B4	V2401	T6
C2010	M6	C2231	M4	C7177	G2	D2200	N3	J2800	N2	L7807	E6	R2424	J5	V2420	L5
C2011	R2	C2232	M3	C7500	B5	D2800	N7	J2801	N2	M	R2425	J5	V7800	D4	
C2012	U4	C2233	M4	C7501	B5	D3000	Q7	J2802	L6	M2400	S3	R2428	L6	X	
C2013	U5	C2234	M3	C7502	B6	F	J2803	N6	N	R2600	G1	X1470	G7		
C2014	T4	C2235	M4	C7503	B6	F2000	T5	J2804	M6	N1470	L8	R2700	R4	X2000	I3
C2015	T4	C2236	M4	C7504	B6	G	J2805	O7	N2150	J5	R2701	R4	X2001	T8	
C2016	T4	C2237	M4	C7506	E7	G2400	H5	J2806	N2	N2400	J5	R2800	O6	X2002	T5
C2017	T4	C2238	M3	C7507	E8	G7500	B5	J2807	O6	N2600	I1	R2900	M2	X2060	C4
C2018	U4	C2239	M5	C7508	F8	G7501	C7	J2808	O6	N6156	K3	R2901	M2	X2400	B6
C2019	U4	C2240	P3	C7509	E8	J	J2809	O6	N7500	D6	R2902	O8	X2700	Q5	
C2020	U4	C2241	O4	C7510	D8	J1000	M8	J2810	O6	N7700	F3	R2903	M2	Z	
C2021	U4	C2270	O2	C7511	D7	J1001	M8	J2811	O6	R	R3000	O7	Z2400	M6	
C2150	U4	C2271	P2	C7512	D8	J1002	M8	J2812	O6	R1470	J6	R3180	O8	Z7700	F7
C2151	J6	C2272	N2	C7513	E8	J1003	M8	J2813	M7	R1471	J7	R6156	K3	Z7800	D3
C2152	R3	C2273	O4	C7516	D7	J1004	N2	J2814	R7	R1472	J7	R6159	J3	Z7801	D3
C2153	J5	C2400	P4	C7517	C6	J1005	N2	J2815	O6	R1473	K8	R6160	J3	Z7802	E5
C2154	Q3	C2401	O4	C7518	C6	J1006	M8	J3100	O6	R1474	J6	R6163	J3	Z7803	D5
C2155	K5	C2402	B4	C7519	C6	J1470	M8	J3101	N6	R1475	J6	R6166	L3		
C2156	K6	C2403	Q3	C7520	E6	J1471	M8	J3102	O6	R1476	L7	R6169	K3		
C2157	P3	C2404	Q2	C7521	C6	J1472	L7	J3103	P6	R1477	K8	R6180	L3		
C2159	Q3	C2405	Q2	C7522	D7	J1473	L7	J3104	P6	R1478	L8	R6181	L3		
C2164	P2	C2406	B4	C7523	D5	J1474	J8	J3105	P6	R2000	T6	R6182	P3		
C2170	P4	C2407	J5	C7524	C5	J2000	I2	J3106	Q6	R2001	O6	R6183	P4		
C2171	P3	C2408	J4	C7525	C7	J2001	I4	J3107	O6	R2002	Q2	R7500	C5		
C2173	P4	C2409	K4	C7526	C8	J2002	H4	J3108	N6	R2003	Q2	R7501	B6		
C2175	R3	C2410	J4	C7527	C7	J2003	H2	J3109	N6	R2004	R3	R7502	B6		
C2176	R4	C2600	G1	C7528	F6	J2004	H3	J3181	O7	R2005	R2	R7503	C6		
C2177	G5	C2601	I2	C7529	C7	J2005	S8	J3182	O8	R2006	T4	R7504	E7		
C2178	G5	C2602	I2	C7530	C7	J2006	S7	J3183	O8	R2007	T5	R7505	E7		
C2179	P2	C2603	I2	C7531	E6	J2007	G6	L	R2008	T4	R7506	E7			
C2180	G5	C2700	P4	C7532	E6	J2008	R2	L2000	T5	R2009	T4	R7507	E8		
C2181	P3	C2701	R5	C7533	F7	J2009	R3	L2001	T4	R2010	T4	R7508	E7		
C2184	R4	C2702	R5	C7701	G2	J2010	R2	L2002	T4	R2011	T4	R7509	F7		
C2187	Q4	C2703	R6	C7702	F2	J2100	G5	L2003	T5	R2012	H2	R7510	E7		
C2200	N5	C2800	O6	C7703	F3	J2101	F5	L2004	T5	R2151	B4	R7511	D5		
C2201	N4	C2880	N6	C7704	F3	J2115	R7	L2005	T5	R2152	J5	R7512	C6		
C2202	P3	C2881	N6	C7705	G3	J2116	O7	L2006	L2	R2153	Q3	R7513	C7		

