

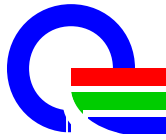

Preliminary



**Quanta Display Inc.
SPECIFICATION**

Doc No. QD17EL0711

Doc. REV.: 00

Issue Date:03/24/2005

**With RoHS
compliant**

Specification for TFT LCD Module

Model No.
QD17EL07 Rev.:11

? **Approved By**

		Quanta Display Inc.



These specification sheets are the proprietary product of Quanta Display Inc. ("QDI") and include materials protected under copyright of QDI. Do not reproduce or cause any third party to reproduce them in any form or by any means, electronic or mechanical, for any purpose, in whole or in part, without the express written permission of QDI.

The device listed in these technical literature sheets was designed and manufactured for use in OA equipment.

In case of using the device for applications such as control and safety equipment for transportation (aircraft, trains, automobiles, etc.), rescue and security equipment and various safety related equipment which require higher reliability and safety, take into consideration that appropriate measures such as fail-safe functions and redundant system design should be taken.

Do not use the device for equipment that requires an extreme level of reliability, such as aerospace applications, telecommunication equipment (trunk lines), nuclear power control equipment and medical or other equipment for life support.

QDI assumes no responsibility for any damage resulting from the use of the device, which does not comply with the instructions, and the precautions specified in these technical literature sheets.

Contact and consult with a QDI sales representative for any questions about this device.

1. Application

This specification applies to a color TFT-LCD module, [QD17EL07 Rev.11](#)

2. Overview

This module is a color active matrix LCD module incorporating amorphous silicon TFT (Thin Film Transistor). It is composed of a color TFT-LCD panel; driver ICs, control circuit and power supply circuit and a backlight unit. Graphics and texts can be displayed on a **1280× 3 × 1024 dots** panel with 16.2 million colors by using **LVDS (Low Voltage Differential Signaling)** to interface and **supplying +5V DC** supply voltage for TFT-LCD panel driving and supply voltage for backlight.

The TFT-LCD panel used for this module has very high aperture ratio. A low-reflection and higher-color-saturation type color filter is also used for this panel. Therefore, high-brightness and high-contrast image, which is suitable for the multimedia use, can be obtained by using this module.

Optimum viewing direction is 6 o'clock.

[Features]

- 1) High aperture ratio, high-brightness & low power consumption.
- 2) Brilliant and high contrast image.
- 3) Small footprint and thin shape.
- 4) SXGA resolution (1024 vertical by 1280 horizontal pixel array).
- 5) LVDS interface.
- 6) PSWG type.
- 7) Wide viewing angle.
- 8) RoHS compliant

3. General Specifications

Parameter	Specifications	Unit
Display size	43(17") Diagonal	mm
Active area	337.9(H)× 270.3(V)	mm
Pixel format	1280 (H)× 1024(V)	Pixel
	(1 pixel = R+G+B dots)	
Pixel pitch	0.264(H) × 0.264 (V)	mm
Pixel configuration	R, G, B vertical stripe	
Display mode	Normally white	
Unit outline dimensions (typ.)*1	296.5(W)× 358.5(H)× 17(T)max.	mm
Mass	1700 max.	g
Surface treatment	Anti-glare and hard-coating 3H	

*1.Note: excluding backlight cables. Outline dimensions are shown in this specification.

4. Input Terminals

4-1. TFT-LCD panel driving

CN1 (LVDS signals and +5V DC power supply)

Using connector: AL2307-A0G1D-P(PII)

Corresponding connector: FI-X30M or FI-X30H (JAE)

Interface Cable Pin Assignments

Pin No.	Symbol	Function	Remark
1	R1IN0-	Receiver signal of Odd side pixels (-)	LVDS
2	R1IN0+	Receiver signal of Odd side pixels (+)	LVDS
3	R1IN1-	Receiver signal of Odd side pixels (-)	LVDS
4	R1IN1+	Receiver signal of Odd side pixels (+)	LVDS
5	R1IN2-	Receiver signal of Odd side pixels (-)	LVDS
6	R1IN2+	Receiver signal of Odd side pixels (+)	LVDS
7	GND		
8	CK1IN-	Clock signal of Odd side pixels (-)	LVDS
9	CK1IN+	Clock signal of Odd side pixels (+)	LVDS
10	R1IN3-	Receiver signal of Odd side pixels (-)	LVDS
11	R1IN3+	Receiver signal of Odd side pixels (+)	LVDS
12	R2IN0-	Receiver signal of Even side pixels (-)	LVDS
13	R2IN0+	Receiver signal of Even side pixels (+)	LVDS
14	GND		
15	R2IN1-	Receiver signal of Even side pixels (-)	LVDS
16	R2IN1+	Receiver signal of Even side pixels (+)	LVDS
17	GND		
18	R2IN2-	Receiver signal of Even side pixels (-)	LVDS
19	R2IN2+	Receiver signal of Even side pixels (+)	LVDS
20	CK2IN-	Clock signal of Even side pixels (-)	LVDS
21	CK2IN+	Clock signal of Even side pixels (+)	LVDS
22	R2IN3-	Receiver signal of Even side pixels (-)	LVDS
23	R2IN3+	Receiver signal of Even side pixels (+)	LVDS
24	GND		
25	GND		
26	NC		
27	GND		
28	V _{DD}	+5V power supply	Power
29	V _{DD}	+5V power supply	Power
30	V _{DD}	+5V power supply	Power

? Note 1? All GND(ground) pins should be connected together.

? Note 2? All V_{DD} (power supply) pins should be connected together.

4-2 Interface block diagram

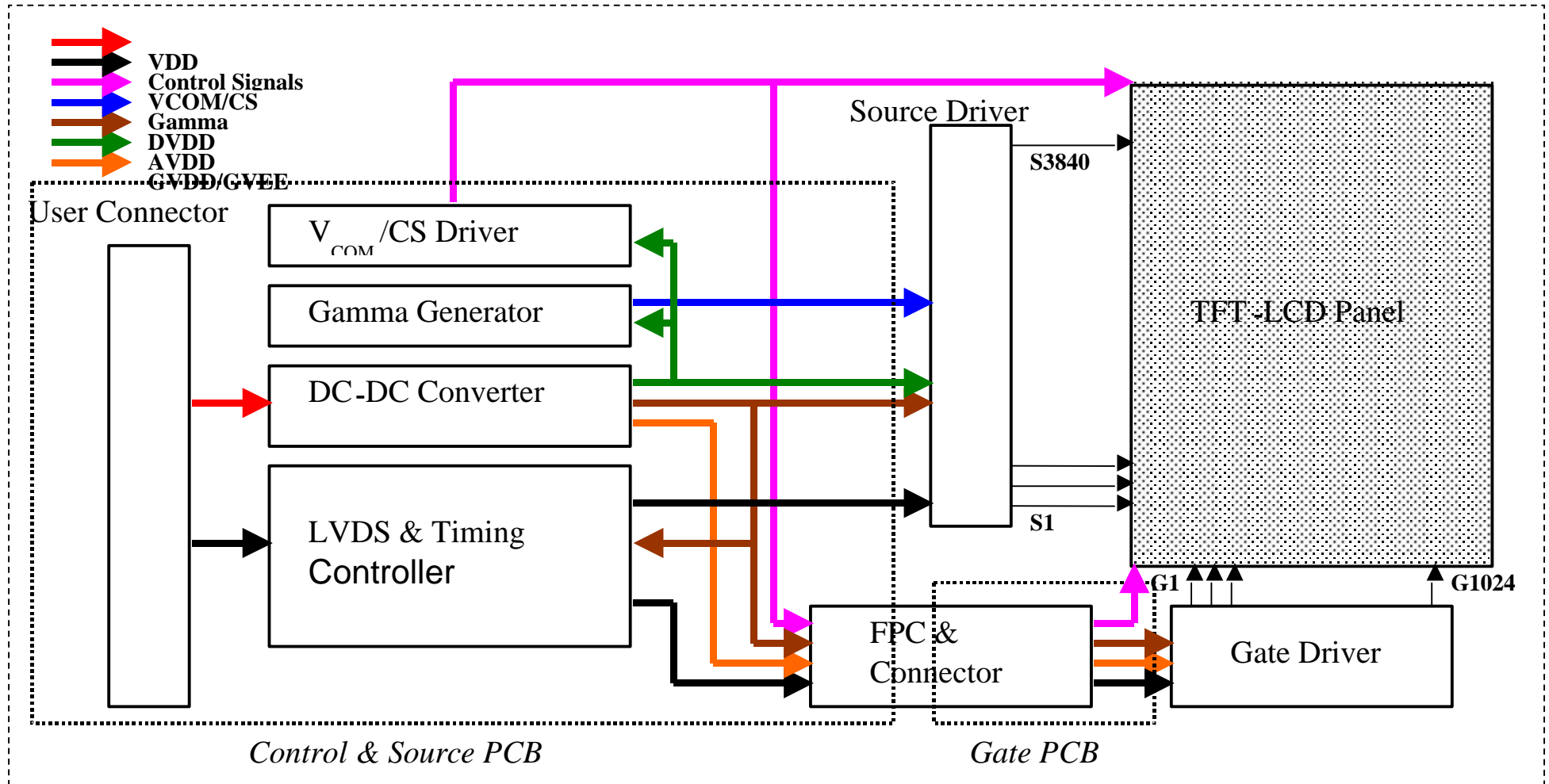

4-3. Backlight driving

Using connector CN2: BHSR-02VS-1 (JST)

Corresponding connector: SM02B-BHSS-1 (JST)

Pin No.	Symbol	Function
1	HIGH	High voltage side
2	GND	Ground

Note) VBLH and VBLC must be connected correctly. If user connects wrongly, the user will be hurt and the module will be broken.

5. Absolute Maximum Ratings

5-1 LCD module

Parameter	Symbol	Condition	Ratings	Unit	Remark
Input voltage	V_I	Ta=25?	- 0.3 ~ VDD+0.3	V	? Note1?
+5V supply voltage	VDD	Ta=25?	-0.3 ~ + 6.0	V	
Storage temperature	Tstg	-	- 20 ~ + 60	?	? Note2?
Operating temperature (Ambient)	Topa	-	0 ~ + 50	?	? Note3?

? Note1? LVDS signals

? Note2? Humidity: 95%RH Max. at Ta? 40? .

Maximum wet-bulb temperature at 39? or less at Ta>40? .

No condensation.

? Note3? When you apply the LCD module for OA system. Please make sure to keep the temperature of LCD module is less than 60°C.

6. Electrical Characteristics
6-1. TFT-LCD panel driving
Ta= 25?

Parameter		Sym.	Min.	Typ.	Max.	Unit	Remark
VDD	Supply voltage	VDD	+4.5	+5.0	+5.5	V	? Note2?
Current dissipation	@ Full Back pattern	IDD	-	760	1200	mA	? Note3?
	@ Full White pattern		-	480		mA	
	@ 1-line on/off pattern		-	700		mA	
	@ 1-dot on/off pattern		-	860		mA	
	@ Mosaic pattern		-	630		mA	
Permissive input ripple voltage		V _{RP}	-	-	100	mV p-p	VDD=+5.5V
Differential input Threshold voltage	High	V _{TH}	-	-	+100	mV	V _{CM} =+1.2V
	Low	V _{TL}	-100	-	-	mV	? Note1?
Terminal resistor		R _T	-	100	-	0	Differential input
Rush current		I _{RUSH}			3	A	Rise time 470uS

? Note1? V_{CM} : Common mode voltage of LVDS driver.

? Note2?

On-off conditions for supply voltage

0.5 < t₁? 10 ms

0 < t₂? 10 ms

0 < t₃? 50 ms

1000 ms? t₄

200 ms? t₅

100 ms? t₆

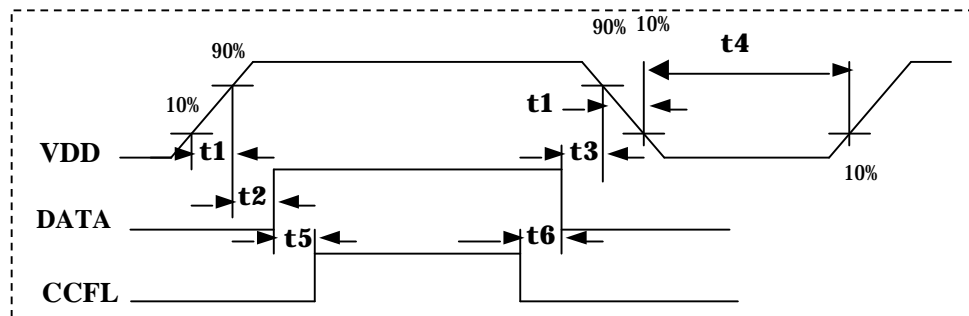
VDD-dip conditions

1) 4.0 V? VDD < 4.5V
t_d? 10 ms

2) VDD < 4 V

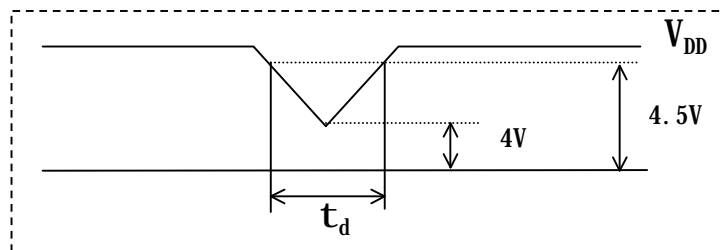

VDD-dip conditions should also follow the On-off conditions for supply voltage

? Note3? Test pattern of current dissipation

[Full white pattern] VDD=+5V

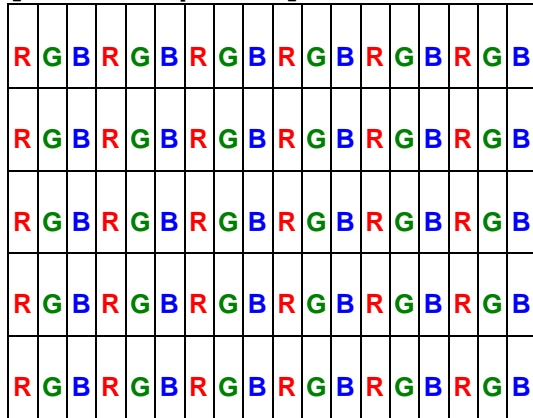

[Full black pattern] VDD=+5V

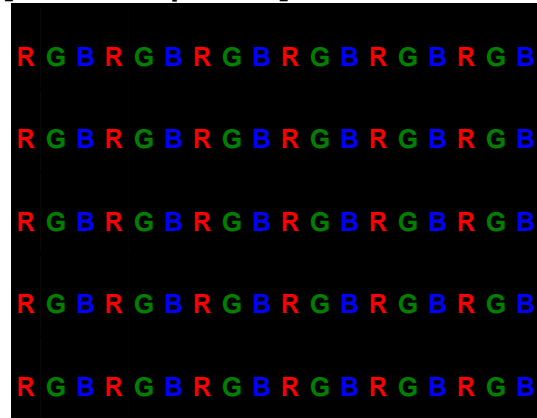

[1 line on/off pattern] VDD=+5V

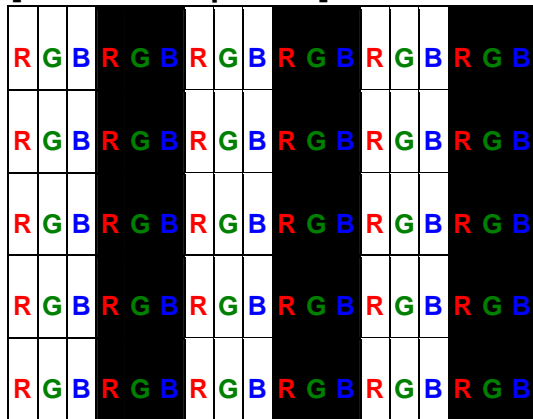

[1 dot on/off pattern] VDD=+5V

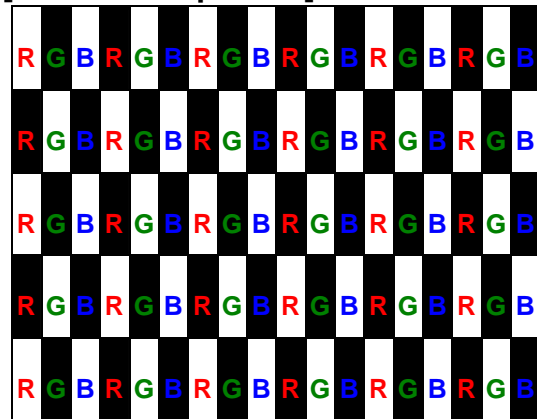

[32x32 Mosaic pattern] VDD=+5V

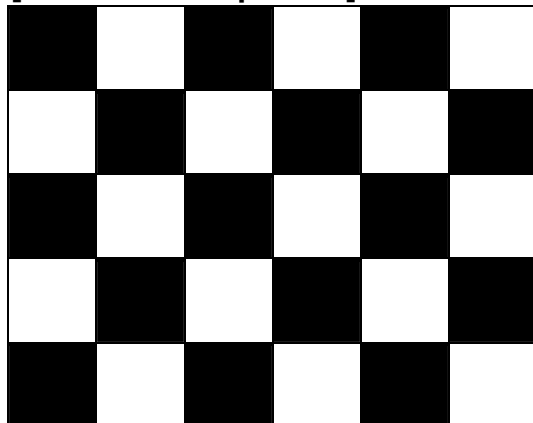

6-2. Backlight driving

The backlight system is an edge-lighting type with 2 CCFT (Cold Cathode Fluorescent Tube).

The characteristics of the lamp are shown in the following table.

Parameter	Symbol	Min.	Typ.	Max.	Unit	Remark
Lamp current range	I_L	4.0	7.0	8.0	mArms	? Note1?
Lamp voltage	V_L	550.8	612	673.2	Vrms	
Lamp power consumption	P_L	-	4.28	-	W	$I_L=6.0mA?$ Note2?
Lamp frequency	F_L	-	47	-	kHz	? Note3?
Kick-off voltage	V_s	-	-	1200	Vrms	$T_a=25?$
		-	-	1500	Vrms	$T_a=0?$? Note4?
Lamp life time	L_L	40000	50000	-	hour	? Note5?

? Note1? Lamp current is measured with current meter for high frequency as shown below.

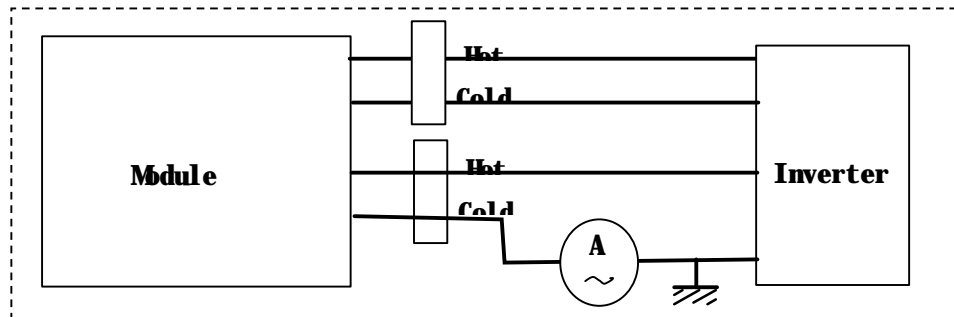

? Note2? Calculated Value for reference ($I_L \times V_L$)

? Note3? Lamp frequency may produce interference with horizontal synchronous frequency, and this may cause beat on the display. Therefore lamp frequency shall be detached as much as possible from the horizontal synchronous frequency and from the harmonics of horizontal synchronous to avoid interference.

? Note4? The voltage above this value should be applied to the lamp for more than 1 second to start-up. Otherwise the lamp may not be turned on.

? Note5? Lamp life time is defined as the time when either ? or ? occurs in the continuous operation under the condition of $T_a = 25?$ and $I_L = 7.0$ mArms.

? Brightness becomes 50 % of the original value under standard condition.

? Kick-off voltage at $T_a = 0?$ exceeds maximum value.

? Note6? The output of the inverter must have symmetrical waveform of voltage and current. The unsymmetrical rate should be less than 10%. You don't use the inverter which has unsymmetrical voltage, unsymmetrical current and spike wave.

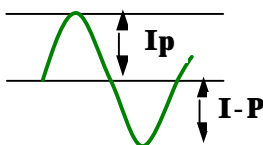

* Unsymmetrical ratio: $(|I_p| - |I_{-p}|) / |I_{rms}| \times 100\%$ 10%

* Distortion ratio: I_p (or I_{-p}) / I_{rms} $2 \pm 10\%$

Note) The performance of the backlight, for example life time or brightness, is much influenced by the characteristics of the DC-AC inverter for the lamp. When you design or order the inverter, please make sure that a poor lighting caused by the mismatch of the backlight and the inverter (miss-lighting, flicker, etc.) never occur. When you confirm it, the module should be operated in the same condition as it is



installed in your instrument.

7. Timing characteristics of LCD module input signals

7-1. Timing characteristics

(This is specified at digital outputs of LVDS driver.)

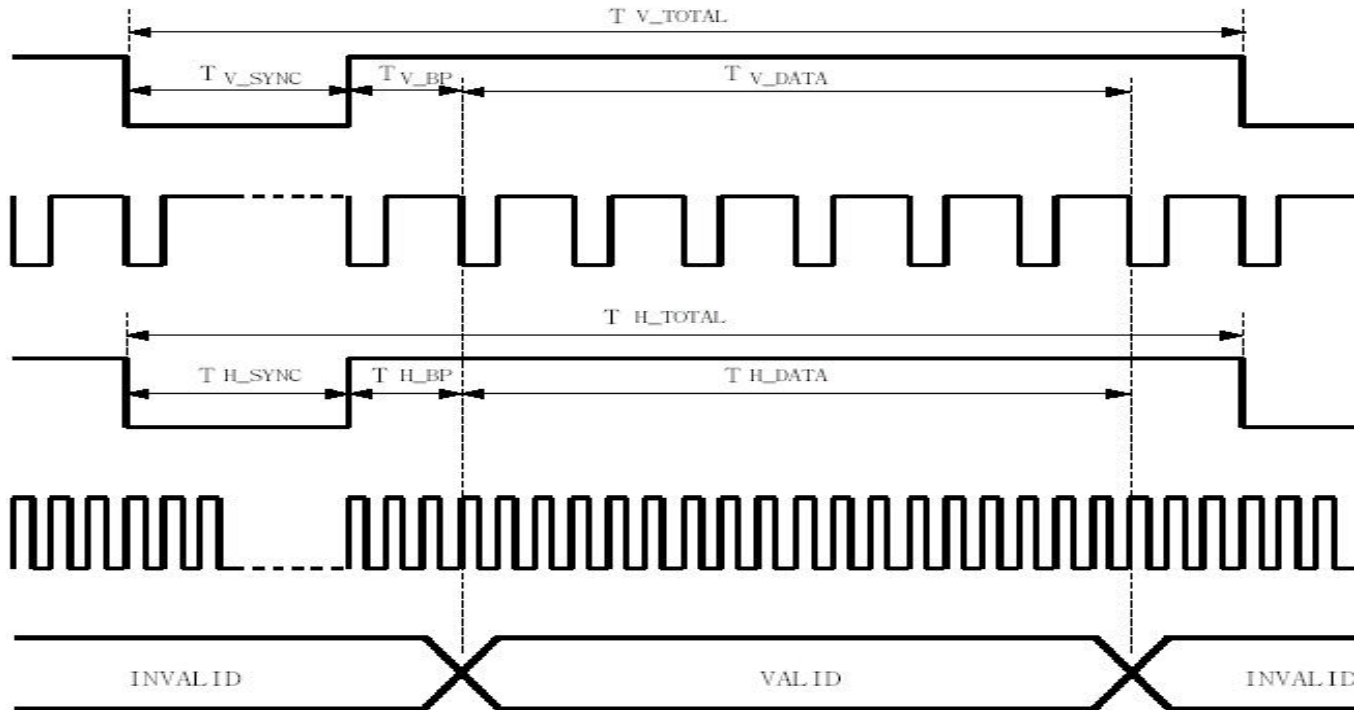

DE MODE:

	Item	Description	Condition	Min.	Typ.	Max.	Unit
Frame	T_{V_TOTAL}	V total line number	-	1029	1066	1600	H
	T_{V_DATA}	Data duration	-	-	1024	-	H
Line	T_{H_TOTAL}	H total pixel number	-	672	844	1400	CLK
	T_{H_DATA}	Data duration	-	-	640	-	CLK

(Clock)

Item	Min.	Typ.	Max.	Unit	Remark
Frequency	40	54	67.5	MHz	

Note)1. Typ. Timing is [1280X1024@64KHz/60Hz](#) SXGA

2. The panel can run at [1280X1024@79.976KHz/75Hz](#) as well.

3. If increase Vsync cycle too much, it may cause flicker.



4. Vsync/Hsync cycle value (TVA / THA) is divided by 4.

7-2. Input Data Signals and Display Position on the screen

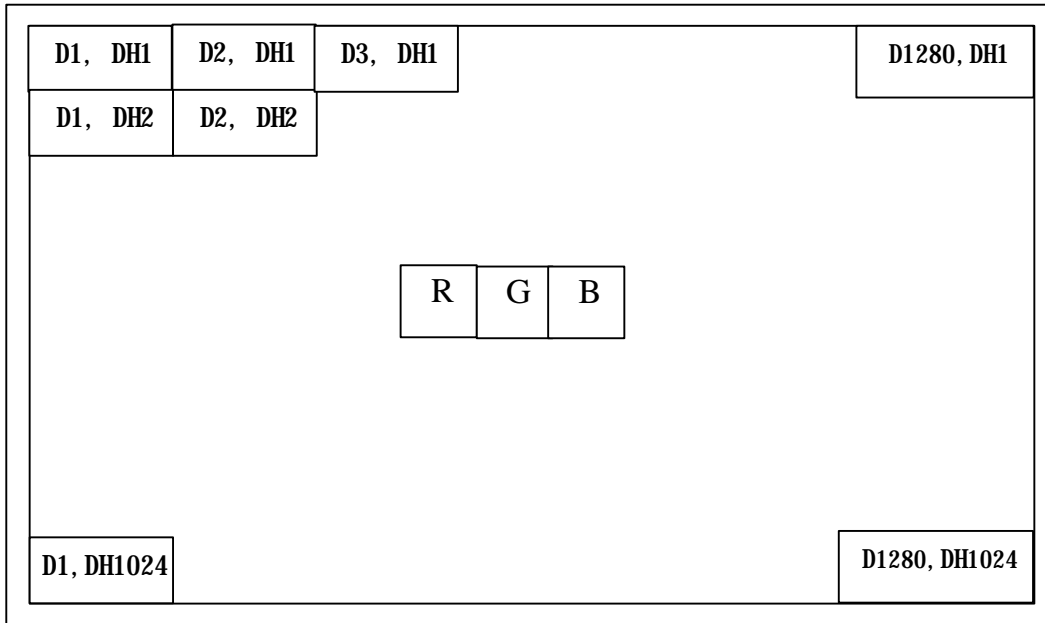

8. Input Signals, Basic Display Colors and Gray Scale of Each Color

	Colors & Gray scale	Data Signal																											
		R0	R1	R2	R3	R4	R5	R6	R7	G0	G1	G2	G3	G4	G5	G6	G7	B0	B1	B2	B3	B4	B5	B6	B7				
Basic Color	Black	0	0	0	0	0	0	0	0	0	0	0	0	0	0	0	0	0	0	0	0	0	0	0	0	0	0		
	Blue	0	0	0	0	0	0	0	0	0	0	0	0	0	0	0	0	1	1	1	1	1	1	1	1	1	1		
	Green	0	0	0	0	0	0	0	0	1	1	1	1	1	1	1	1	0	0	0	0	0	0	0	0	0	0		
	Cyan	0	0	0	0	0	0	0	0	1	1	1	1	1	1	1	1	1	1	1	1	1	1	1	1	1	1		
	Red	1	1	1	1	1	1	1	1	0	0	0	0	0	0	0	0	0	0	0	0	0	0	0	0	0	0		
	Magenta	1	1	1	1	1	1	1	1	0	0	0	0	0	0	0	0	1	1	1	1	1	1	1	1	1	1		
	Yellow	1	1	1	1	1	1	1	1	1	1	1	1	1	1	1	1	0	0	0	0	0	0	0	0	0	0		
	White	1	1	1	1	1	1	1	1	1	1	1	1	1	1	1	1	1	1	1	1	1	1	1	1	1	1		
Gray Scale of Red	Black	0	0	0	0	0	0	0	0	0	0	0	0	0	0	0	0	0	0	0	0	0	0	0	0	0	0		
	⚡	1	0	0	0	0	0	0	0	0	0	0	0	0	0	0	0	0	0	0	0	0	0	0	0	0	0		
	Darker	0	1	0	0	0	0	0	0	0	0	0	0	0	0	0	0	0	0	0	0	0	0	0	0	0	0		
	⚡				⚡							⚡							⚡										
	Bright	1	0	1	1	1	1	1	1	0	0	0	0	0	0	0	0	0	0	0	0	0	0	0	0	0	0		
	⚡	0	1	1	1	1	1	1	1	0	0	0	0	0	0	0	0	0	0	0	0	0	0	0	0	0	0		
	Red	1	1	1	1	1	1	1	1	0	0	0	0	0	0	0	0	0	0	0	0	0	0	0	0	0	0		
Gray Scale of Green	Black	0	0	0	0	0	0	0	0	0	0	0	0	0	0	0	0	0	0	0	0	0	0	0	0	0	0		
	⚡	0	0	0	0	0	0	0	0	1	0	0	0	0	0	0	0	0	0	0	0	0	0	0	0	0	0		
	Darker	0	0	0	0	0	0	0	0	0	1	0	0	0	0	0	0	0	0	0	0	0	0	0	0	0	0		
	⚡				⚡							⚡							⚡										
	Bright	0	0	0	0	0	0	0	0	1	0	1	1	1	1	1	1	0	0	0	0	0	0	0	0	0	0		
	⚡	0	0	0	0	0	0	0	0	0	1	1	1	1	1	1	1	0	0	0	0	0	0	0	0	0	0		
	Green	0	0	0	0	0	0	0	0	1	1	1	1	1	1	1	1	0	0	0	0	0	0	0	0	0	0		
Gray Scale of Blue	Black	0	0	0	0	0	0	0	0	0	0	0	0	0	0	0	0	0	0	0	0	0	0	0	0	0	0		
	⚡	0	0	0	0	0	0	0	0	0	0	0	0	0	0	0	0	1	0	0	0	0	0	0	0	0	0		
	Darker	0	0	0	0	0	0	0	0	0	0	0	0	0	0	0	0	0	1	0	0	0	0	0	0	0	0		
	⚡				⚡							⚡							⚡										
	Bright	0	0	0	0	0	0	0	0	0	0	0	0	0	0	0	0	1	0	1	1	1	1	1	1	1	1		
	⚡	0	0	0	0	0	0	0	0	0	0	0	0	0	0	0	0	0	1	1	1	1	1	1	1	1	1		
	Blue	0	0	0	0	0	0	0	0	0	0	0	0	0	0	0	0	1	1	1	1	1	1	1	1	1	1		

0 : Low level voltage, 1 : High level voltage

9.Optical Characteristics

Ta=25? , VDD=+5V

Parameter	Symbol	Condition	Min.	Typ.	Max.	Unit	Remark	
Viewing Angle Range	Horizontal	? 21,? 22	CR>10	60	70		Deg.	? Note1,4?
	Vertical	? 11		55	65		Deg.	
		? 12		50	60		Deg.	
	Horizontal	? 21,? 22	CR>5	70	80		Deg.	
	Vertical	? 11		65	75		Deg.	
		? 12		60	70		Deg.	
Contrast ratio	C R n	? =0°	400	600	-		? Note2,4?	
Response time	t	? =0°	-	8	16	ms	? Note3,4?	
Rise time	t r			2		ms		
Fall time	t d			6		ms		
Chromaticity of White (CIE 1931)	Wx		0.283	0.313	0.343		? Note4?	
	Wy		0.299	0.329	0.359			
Chromaticity of Red (CIE 1931)	Rx		0.612	0.642	0.672			
	Ry		0.311	0.341	0.371			
Chromaticity of Green (CIE 1931)	Gx		0.249	0.279	0.309			
	Gy		0.580	0.610	0.640			
Chromaticity of Blue (CIE 1931)	Bx		0.113	0.143	0.173			
	By		0.053	0.083	0.113			
Luminance of white	Y L		220	270		Cd/m ²		IL = 7.0mArms
White Uniformity	d W		-	1.25	1.3			? Note5?

The optical characteristics shall be measured in a dark room or equivalent state with the method shown in Fig.3.

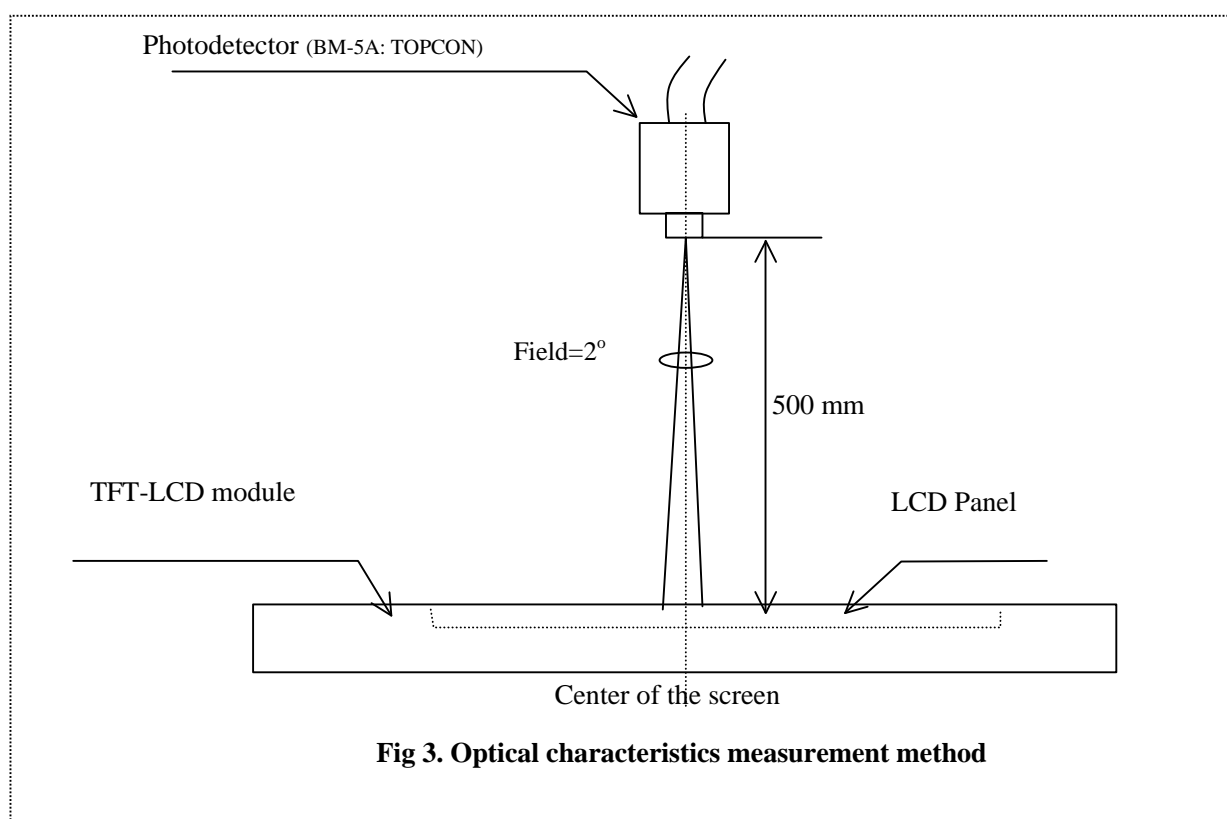
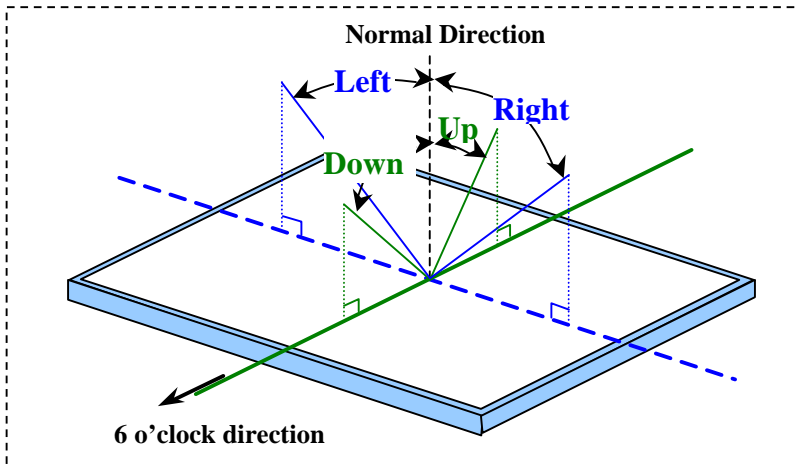

Fig 3. Optical characteristics measurement method

? Note1? Definitions of viewing angle range:



? Note2? Definition of contrast ratio:

The contrast ratio is defined as the following.

$$\text{Contrast Ratio (CR)} = \frac{\text{Luminance (brightness) with all pixels white}}{\text{Luminance (brightness) with all pixels black}}$$

? Note3? Definition of response time:

The response time is defined as the following figure and shall be measured by switching the input signal for "black" and "white" .

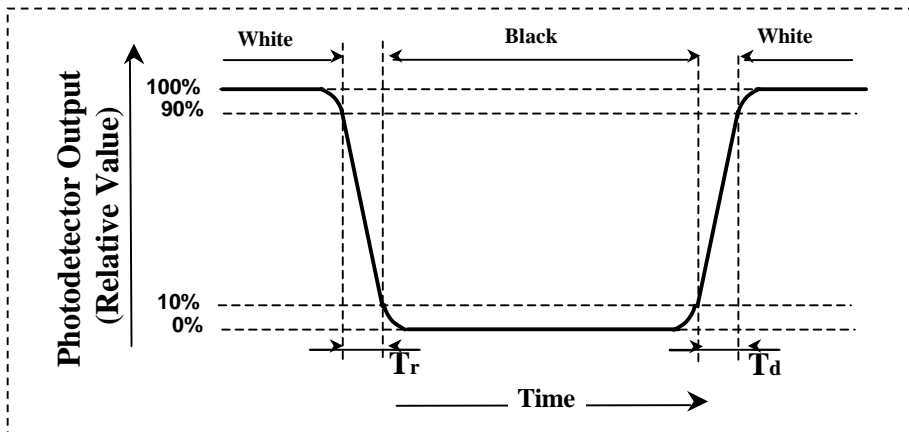

? Note4? This shall be measured at center of the screen.

? Note5? Definition of white uniformity:

9 points measurements

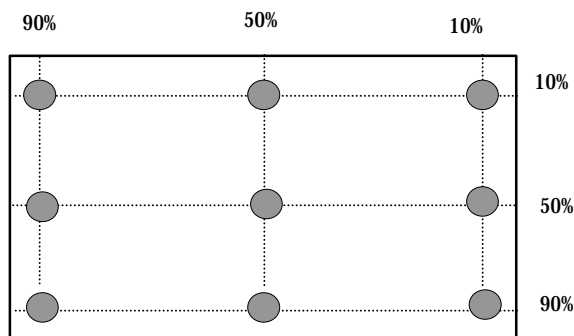

$$dw = \frac{\text{Maximun Luminance of 9 points}}{\text{Minimum Luminance of 9 points}}$$

11. Display Quality

The display quality of the color TFT-LCD module shall be in compliance with the Incoming Inspection Standard.

12. Handling Precautions

- a) Be sure to turn off the power supply when inserting or disconnecting the cable.
- b) Be sure to design the cabinet so that the module can be installed without any extra stress such as warp or twist.
- c) Since the front polarizer is easily damaged, pay attention not to scratch it.
- d) Wipe off water drop immediately. Long contact with water may cause discoloration or spots.
- e) When the panel surface is soiled, wipe it with absorbent cotton or other soft cloth.
- f) Since the panel is made of glass, it may break or crack if dropped or bumped on hard surface. Handle with care.
- g) Since CMOS LSI is used in this module, take care of static electricity and injure the human earth when handling.
- h) Observe all other precautionary requirements in handling components.
- i) This module has its circuitry PCBs on the rear side and should be handled carefully in order not to be stressed.
- j) Laminated film is attached to the module surface to prevent it from being scratched. Peel the film off slowly just before the use with strict attention to electrostatic charges. Ionized air shall be blown over during the action. Blow off the 'dust' on the polarizer by using an ionized nitrogen gun, etc..
- k) Cold cathode fluorescent lamp in LCD panel contains a small amount of mercury, please follow local ordinance or regulation for disposal.

13. Reliability test items

No.	Test item	Conditions
1	High temperature storage test	Ta = 60? 240h
2	Low temperature storage test	Ta = -20? 240h
3	High temperature & High humidity operation test	Ta = 40? ; 90 %RH 240h ; (As remark #3) (No condensation)
4	High temperature operation test	Ta = 50? 240h (The panel temp. must be less than 60?)
5	Low temperature operation test	Ta = 0? 240h
6	Vibration test (non- operating)	Frequency: 10~ 500Hz, 1.0G, Test period : 3 hours (1 hour for each direction of X,Y,Z)
7	Shock test (Non- operating)	Max. Gravity: 50G Pulse width: 11 ms, Half sine wave Direction : ± X,± Y,± Z Once for each direction.

Remark:

- (1) A failure is defined as the appearance of pixel failed on any color layer or the appearance of horizontal or vertical lines, bars etc.
- (2) Low temperature storage “ Panel must return to operating temperature range prior to activation.”
- (3) Hi temperature / Humidity test
Max. wet-bulb temperature is less than 39°C ; At glass temperature high than 40 °C.
Temperature and relative humidity range is shown in the figure below.

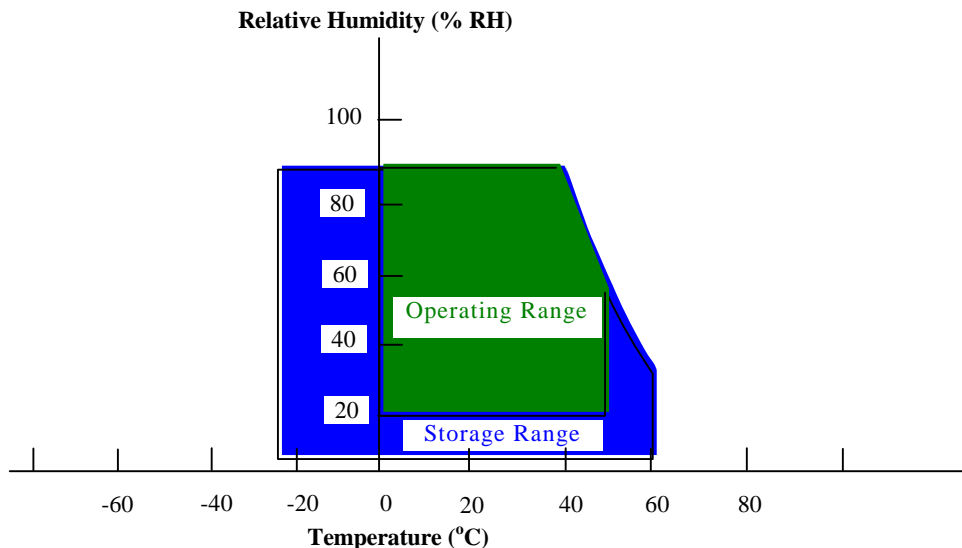

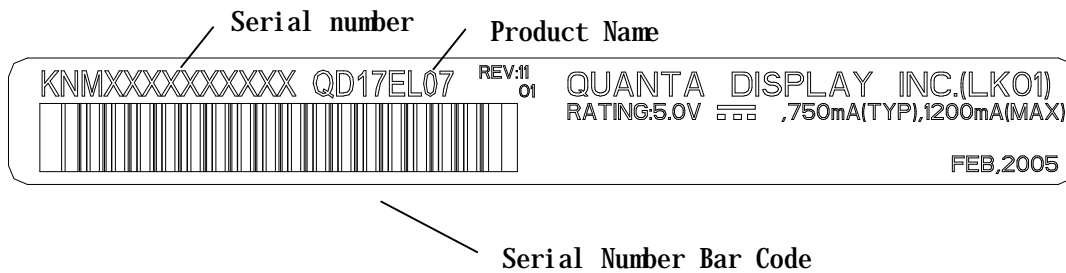
14. Others**1) Lot No. Label**

KNMXXXXXXXXXX Digital code 4, 5 is Date code.

Digital 4 (Year) 1: 2001, 2: 2002, 3:2003,....

Digital 5 (Month) 1: Jan, 2: Feb,... , A:Oct, B:Nov., C: Dec. Lot No.

- 1) Disassembling the module can cause permanent damage and should be strictly avoided.
- 2) Please be careful since image retention may occur when a fixed pattern is displayed for a long time.
- 3) If any problem occurs in relation to the description of this specification, it shall be resolved through discussion with spirit of cooperation.

15. Packing form

i) Package quantity in one box : 10pcs

ii) Box Size : 490 (L)x 396 (W)x 440 (H) mm

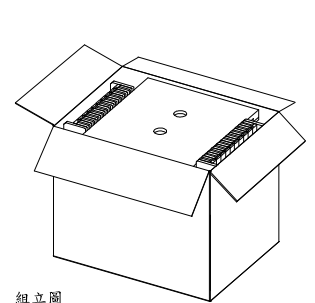

組立圖

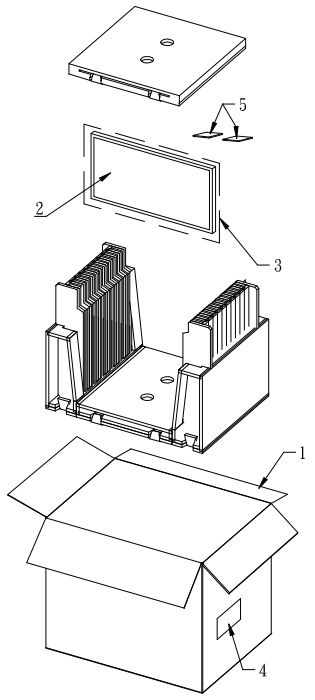

包裝爆炸圖

PART NAME	PART CODE	Q'ty
1 Carton	44100005000	1
2 LCD Module	17" Module	10
3 PE-Bag	26700000100	10
4 Carton label	440201000000	1
5 乾燥劑	44300000000	2
6 Tape	西維 PP37 W=60mm	2

CARTON OUTLINE: 490(L) X 396(W) X 440(H) mm
TOTAL WEIGHT: 23KG

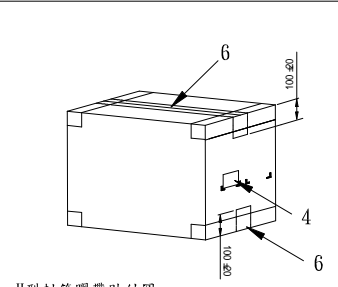

H型封箱膠帶貼付圖

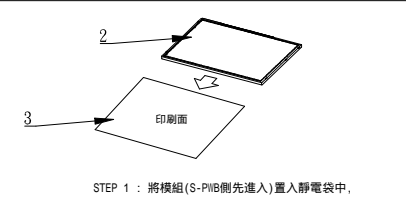

STEP 1 : 將模組(S-PIB側先進入)置入靜電袋中。

Quanta Display Inc.				ORIGINAL MODEL	
<i>CONFIDENTIAL</i>				MATERIAL FINISH	
UNIT	mm	SHEET	A4	PART NAME	BAG ASSEMBLY
SCALE		SIZE		PART NUMBER	
DATE	DESIGN	DSN CK	DSN CK	ENG APPD	
				DRAWING NUMBER	

DEG	A	B	C	D	ANGLE
0-5	±0.02	±0.05	±0.1		0°-30' ±0.1°
5-10	±0.05	±0.1	±0.15		31°-60' ±0.3°
10-50	±0.1	±0.15	±0.2		61°-90' ±0.5°
50-100	±0.15	±0.2	±0.25		
100	±0.15%	±0.2%	±0.25%		

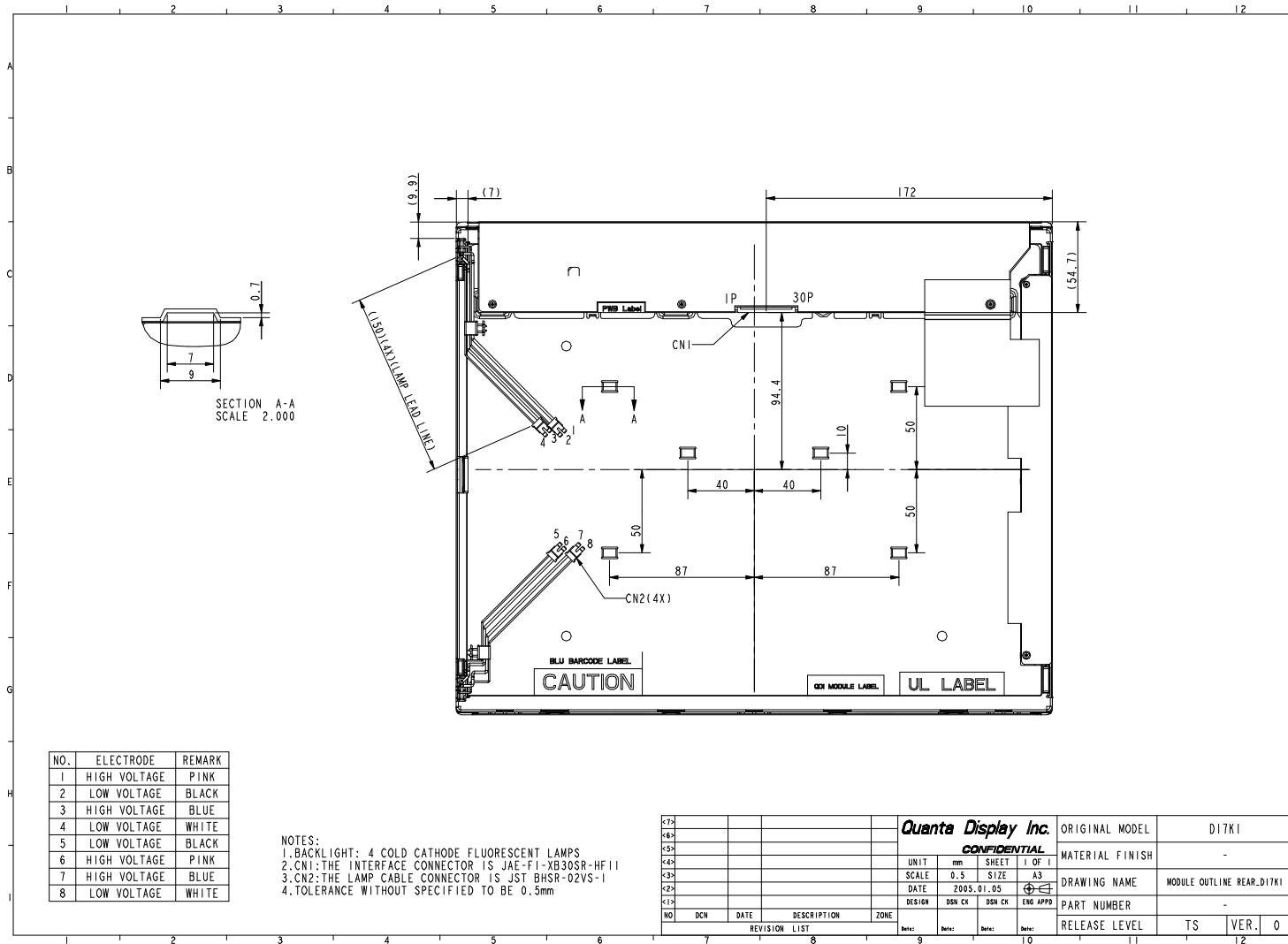

NO.	ELECTRODE	REMARK
1	HIGH VOLTAGE	PINK
2	LOW VOLTAGE	BLACK
3	HIGH VOLTAGE	BLUE
4	LOW VOLTAGE	WHITE
5	LOW VOLTAGE	BLACK
6	HIGH VOLTAGE	PINK
7	HIGH VOLTAGE	BLUE
8	LOW VOLTAGE	WHITE

NOTES:
 1. BACKLIGHT: 4 COLD CATHODE FLUORESCENT LAMPS
 2. CNI: THE INTERFACE CONNECTOR IS JAE-FI-XB30SR-HF11
 3. CN2: THE LAMP CABLE CONNECTOR IS JST BHSR-02VS-1
 4. TOLERANCE WITHOUT SPECIFIED TO BE 0.5mm

				Quanta Display Inc.		ORIGINAL MODEL	D17K1	
				CONFIDENTIAL		MATERIAL FINISH	-	
				UNIT	mm	SHEET	1 OF 1	
				SCALE	0.5	SIZE	A3	
				DATE	2005.01.05	DRAWING NAME	MODULE OUTLINE REAR.D17K1	
				DESIGN	DSN CK	DSN CK	ENG APPD	
NO	DCN	DATE	DESCRIPTION	ZONE	DATE	DATE	DATE	DATE
REVISION LIST								
						PART NUMBER	-	
						RELEASE LEVEL	TS	VER. 0