

CD RECEIVER

KDC-MP408U/MP438U/X492
 KDC-MP5039U/MP5539U
 KDC-W5041UA/W5041UG
 KDC-W5141UAY/W5141UGY
 KDC-W5541U/W5641UY
SERVICE MANUAL

KENWOOD

Kenwood Corporation

© 2008-2 PRINTED IN JAPAN
 B53-0614-00 (N) 519

KDC-MP408U : Panel assy (A64-4400-02)

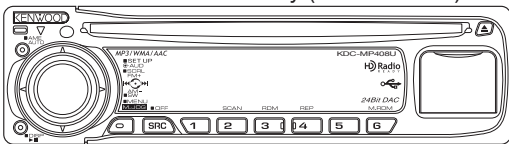

KDC-MP438U : Panel assy (A64-4399-02)

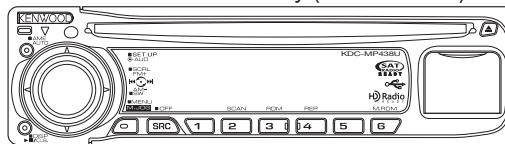

KDC-MP5039U : Panel assy (A64-4402-02)

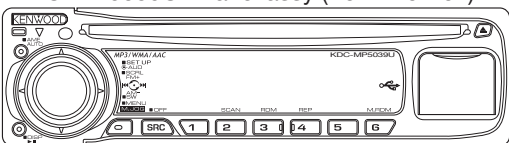

KDC-MP5539U : Panel assy (A64-4401-02)

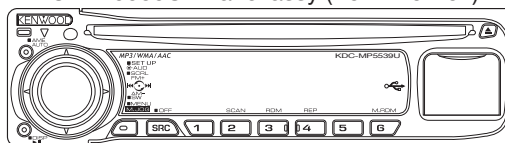

KDC-W5041Ux : Panel assy (A64-4404-02)

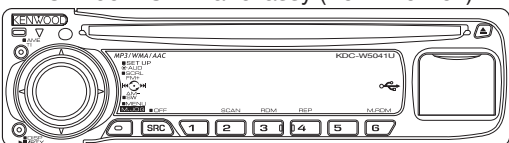

KDC-W5141Uxx : Panel assy (A64-4406-02)

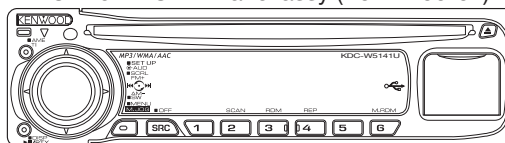

KDC-W5541U : Panel assy (A64-4403-02)

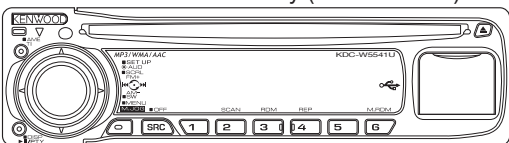

KDC-W5641UY : Panel assy (A64-4405-02)

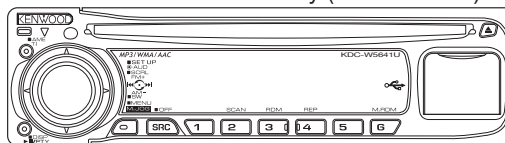

KDC-X492 : Panel assy (A64-4398-02)

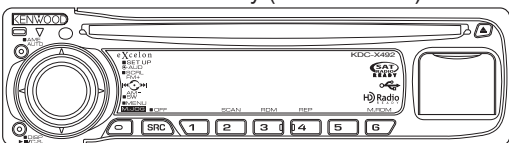

TDF SPARE-PANEL

MAIN UNIT NAME	TDF PARTS No.	TDF NAME
KDC-MP408U	Y33-2920-62	TDF-MP84DT
KDC-MP438U	Y33-2920-61	TDF-MP84D
KDC-MP5039U	Y33-2920-64	TDF-MP5039U
KDC-MP5539U	Y33-2920-63	TDF-MP5539U
KDC-W5041UA	Y33-2920-66	TDF-W5041UA
KDC-W5041UG	Y33-2920-67	TDF-W5041UG
KDC-W5141UAY	Y33-2920-66	TDF-W5041UA
KDC-W5141UGY	Y33-2920-67	TDF-W5041UG
KDC-W5541U	Y33-2920-65	TDF-W5541U
KDC-W5641UY	Y33-2920-65	TDF-W5541U
KDC-X492	Y33-2920-60	TDF-84DX

* Escutcheon
 (B07-xxxx-xx)

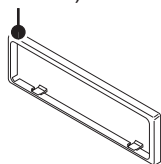

* Carrying case
 (W01-xxxx-xx)

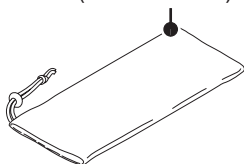

Mounting hardware assy
 (J21-9716-03)

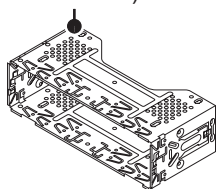

* Screw (4x16)
 (N84-4016-48)

* DC cord
 (E30-6428-05)

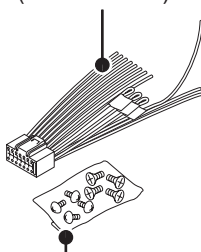

* Screw set
 (N99-1757-15)

* DC cord
 (E30-6671-05)

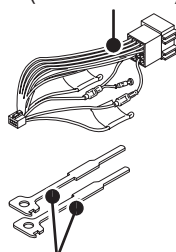

Lever
 (D10-7012-04) x2

* Remote controller assy (RC-547)
 (A70-2085-05)



Battery
 (Not supplied)

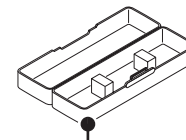

* Plastic cabinet assy
 (A02-2755-13)

* Depends on the model. Refer to the parts list.



BLOCK DIAGRAM

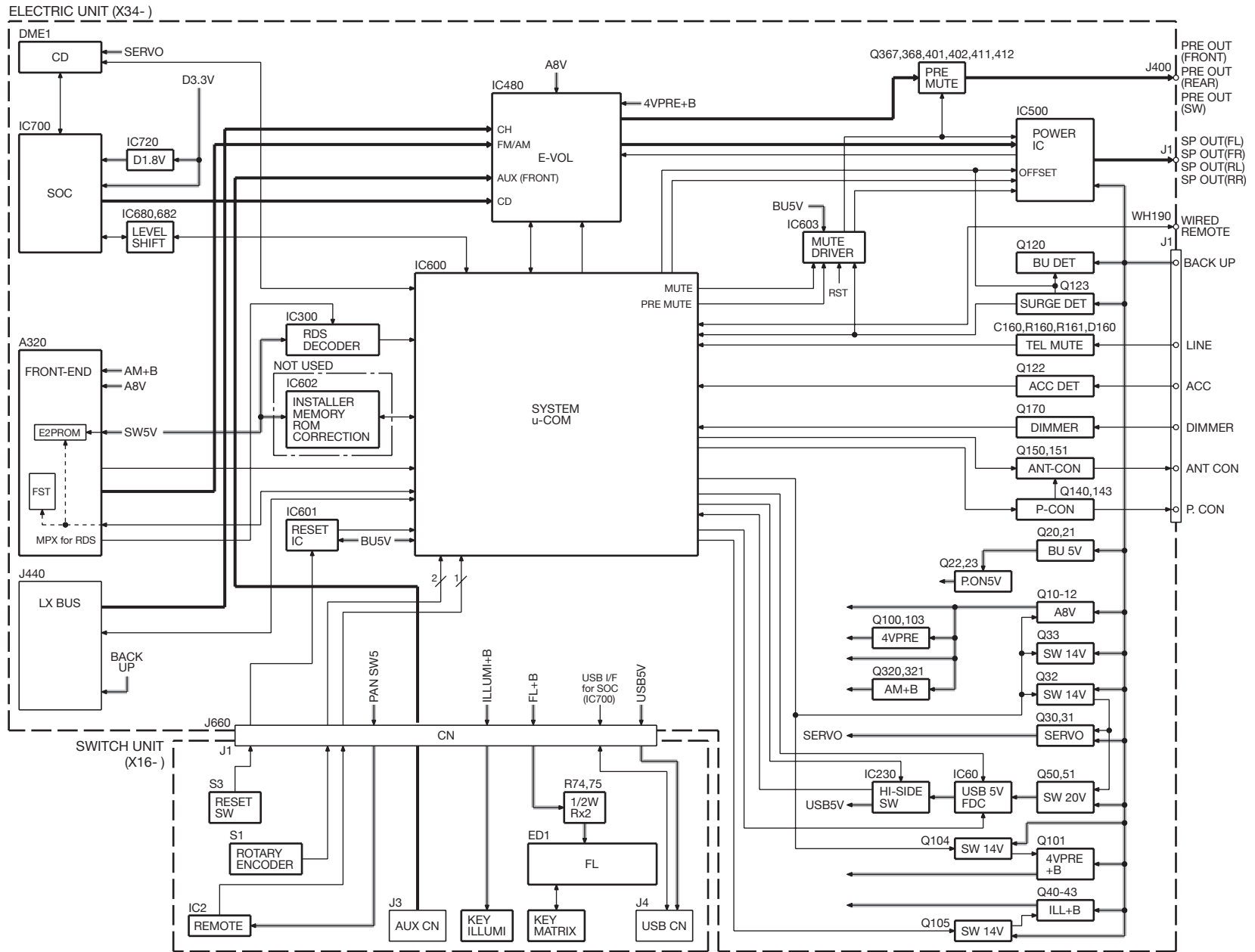

BLOCK DIAGRAM

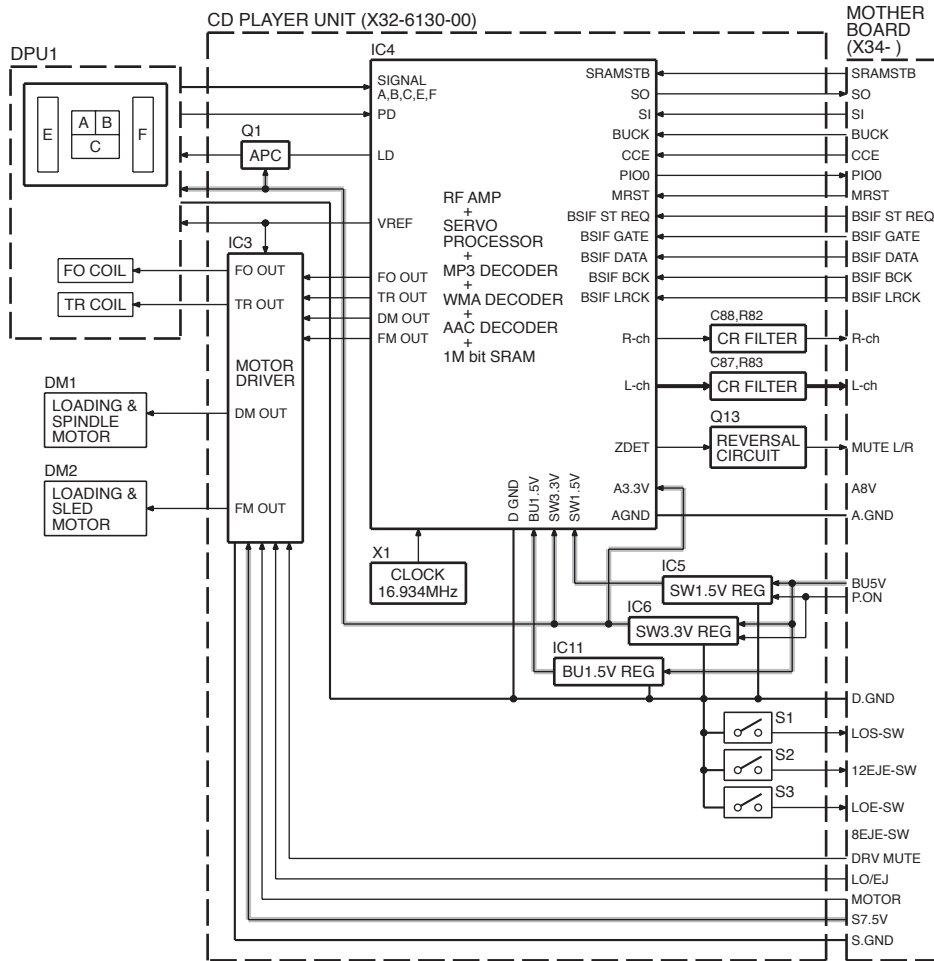

COMPONENTS DESCRIPTION

● ELECTRIC UNIT (X34-577x-xx)

Ref. No.	Application / Function	Operation / Condition / Compatibility
IC10	A8V REF Power Supply	Outputs 1.27V.
IC20	D3.3V REG	Outputs 1.8V. Power supply for SOC.
IC60	SW REG	Outputs 5.0V. Power supply for D5V, FL+B and USB5V.
IC100	OP-AMP	Reference supply for 4V pre-out.
IC230	Hi-side SW	Overcurrent protection of USB power supply. When pin4 goes Hi, USB5V is ON.
IC300	RDS Decoder	Decodes RDS signal.
IC480	E-VOL	Controls the source, volume and tone.
IC500	Power IC	Amplifies the front L/R and the rear L/R to 50W maximum.
IC600	System μ-COM	Controls FM/AM tuner, the changer, CD mechanism, USB, panel, volume and tone.
IC601	Reset IC	Lo when detection voltage goes below 3.6V.
IC603	Muting Logic IC	Controls logic for muting.

COMPONENTS DESCRIPTION

Ref. No.	Application / Function	Operation / Condition / Compatibility
IC680,682	Level Shift	Converts 3.3V to 5V.
IC700	SOC (System On Chip)	Decodes MP3 or other files of audio/decompression standards by software based architecture.
IC750	iPod Authentication Coprocessor	For iPod authentication.
Q10~12	A8V AVR	When Q12's base goes Hi, A8V AVR outputs 8.0V.
Q20,21	BU5V AVR	While BU is applied, BU5V AVR outputs +5V.
Q22,23	P.ON5V	When Q23's base goes Hi, SW5V outputs +5V.
Q30,31	Servo+B AVR	When Q31's base goes Hi, Servo+B AVR outputs 7.5V.
Q32,33,104,105	SW14V	When Q33's (or Q105's) base goes Hi, SW14V outputs 14V.
Q40~43	ILL+B AVR	When Q43's base goes Hi, ILL+B outputs 10.5V.
Q50,51	Serge Protect for IC1	Output 20V when BU is over 20V.
Q100,103	4VPRE+B Protect	When 4VPRE+B is overcurrent, Q100 and Q103 turn Q101 off.
Q101	4VPRE+B AVR	When Q100's base is 8V, 4VPRE+B outputs 7.4V.
Q120	BU DET	When the base goes Hi, Q120 is turned on.
Q122	ACC DET	When the base goes Hi, Q122 is turned on.
Q123	Serge DET	When the base goes Hi, BU DET is turned off.
Q140,143	P-CON SW	When Q143's base goes Hi, AVR outputs 14V.
Q141,142	P-CON Protection	When P.CON output voltage decrease is detected, output protection is made. When P.CON SW is ON, malfunction of Q140 is protected.
Q150,151	P-ANT SW	When Q151's base goes Hi, P-ANT SW outputs 14V.
Q170	Small Lamp DET SW	When the base goes Hi, Q170 is turned on.
Q320,321	AM+B	When Q321's base goes Hi, AM+B is output.
Q367,368,401, Q402,411,412	Pre-out Mute SW	When a base goes Hi, pre-out is muted.
Q500	Electric Discharge Circuit for C508 (SVR)	When the base goes Lo, Q500 is turned on.

● SWITCH UNIT (X16-622x-xx)

Ref. No.	Application / Function	Operation / Condition / Compatibility
IC2	Remote Control Sensor	
Q5,21	PAN5V SW	When Q5's base goes Hi, PAN5V outputs 5V.
Q20	VFD Restart	In condition of the base is Hi, key-scan starts at the same time as POWER ON.
Q22~24	Grid Driver	When each transistor's base is Lo, grid is ON.

● CD PLAYER UNIT (X32-6130-00)

Ref. No.	Application / Function	Operation / Condition / Compatibility
IC3	4ch BTL Driver	Driver for focusing & tracking coil, driver for sled & spindle motor, and operation for disc loading & ejection.
IC4	Servo DSP with built-in Audio DAC	With built-in MP3/WMA/AAC decoder and 1M-bit-SRAM.
IC5	D1.5V REG.	Power supply for digital 1.5V.
IC6	D3.3V REG.	Power supply for digital 3.3V.
IC11	BU1.5V REG.	Power supply for back-up 1.5V.
Q1	APC (Auto Power Control)	Drives LD (Laser Diode).
Q13	Inverter	Inverts ZDET signal.
D2	Laser Diode Protection	Prevents reverse bias which is applied to laser. Laser destruction prevention.
D3,4	Static Electricity Countermeasure	Prevents malfunction by static electricity.

MICROCOMPUTER'S TERMINAL DESCRIPTION

● SYSTEM μ -COM: IC600 on X34- (ELECTRIC UNIT)

Pin No.	Pin Name	I/O	Application	Truth Value Table	Processing / Operation / Description
1	REMO	I	External display remote control input Panel remote control input		
2	LX REQ M	O	Communication request to slave unit		
3-5	NC	-	Not used		Output L fixed
6	BYTE	-			
7	CNVSS	-			
8	XCIN	-	Sub clock		32.768kHz
9	XCOU	-	Sub clock		32.768kHz
10	RESET	-			
11	XOUT	-	Main clock		12.00MHz
12	VSS	-			
13	XIN	-	Main clock		12.00MHz
14	VCC1	-			
15	NMI	-			
16	LX REQ S	I	Communication request from slave unit		
17	RDS CLK	I	RDS decoder clock input		
18	PANEL DET	I	Detection of panel connector detached/attached		H: Panel detached, L: Panel attached
19	PON AM	I/O	AM power supply control		AM reception: H, No AM reception: Hi-Z
20	TUN IFC OUT	I	Front-end IFC-OUT input		H: Station found, L: No station
21	RDS AFS M	I/O	Noise detection time constant SW		
22	RDS QUAL	I/O	RDS decoder QUAL input		
23	RDS DATA	I	RDS decoder data input		
24	USB SYNC	O	Clock output for SW-REG		
25,26	NC	-	Not used		Output L fixed
27	TUN SCL	I/O	Front-end I2C clock input/output		MAX 400kHz
28	TUN SDA	I/O	Front-end I2C data input/output		
29	VFD DATA	I/O	VFD data input/output		
30	VFD INT	I	VFD INT input		
31	VFD CLK	O	VFD clock output		125kHz
32	ROTARY CCW	I	VOL key detection		Detects Pulse 15-pulse/360°, 2-click/1-pulse
33	S SYS DATA	O	Bolero serial output		
34	S SOC DATA	I	Bolero serial input		
35	S SOC SCL	I	Bolero serial clock input		
36-38	NC	-	Not used		Output L fixed
39	ROMCOR DET	I	E2PROM and Bolero writing request		H: Writing
39	EPM	I	EPM input when writing		
40	NC	-	Not used		
41	VFD RST	O	VFD reset		H: Reset cancelled, L: Reset

MICROCOMPUTER'S TERMINAL DESCRIPTION

Pin No.	Pin Name	I/O	Application	Truth Value Table	Processing / Operation / Description
42	ROTARY CW	I	VOL key detection		Detects Pulse 15-pulse/360°, 2-pulse/1-click
43	CD MUTE	I	CD mute request		L: Mute request (Bolero), H: Normal condition
44	VFD CE	O	VFD control request		H: VFD data transfer ready
45	NC	-	Not used		Output L fixed
46	PON	O	Power supply control		H: Power ON, L: Power OFF
47,48	NC	-	Not used		Output L fixed
49	CD LOE LIM SW	I	CD detection (Chucking SW)		H: Loading completed, L: No disc
50,51	NC	-	Not used		Output L fixed
52	CD LOEJ	I/O	CD motor control	①	Refer to the truth value table
53	CD MOTOR	O	CD motor control	①	Refer to the truth value table
54	CD LOS SW	I	CD loading detection		
55	CD DISC12 SW	I	12cm CD detection		
56	PON PANEL	I/O	Panel 5V power supply		ON (For 11 minutes after ACC OFF): L Momentary power down or Panel detached or 11 minutes after ACC OFF: Hi-Z
57	NC	-	Not used		Output L fixed
58	SOC S RST	O	SOC reset		H: Normal condition, L: Reset (Bolero)
59	PON ILL	O	Key illumination power supply		H: Power ON, L: Power OFF
60	VCC2	-			
61	SOC S STOP	O	SOC stop		H: Normal condition, L: SOC stopped (Bolero)
62	VSS	-			
63	TYPE 1	I	Destination setting		
64	TYPE 2	I	Destination setting		
65	NC	-	Not used		Output L fixed
66	ANT CON	O	Power antenna control		Tuner ON: H
67	PCON	O	External amplifier control		
68,69	NC	-	Not used		Output L fixed
70	ILLUMI DET	I	Dimmer illumination detection		L: ON, H: OFF
71	NC	-	Not used		Output L fixed
72	ACC DET	I	ACC power supply detection		ACC found: L, No ACC: H
73	BU DET	I	Detection of momentary power down		BU found: L, Momentary power down: H
74	S SYS REQ	O	Communication request of system μ -com \rightarrow SOC		
75	S SOC REQ	I	Communication request of SOC \rightarrow system μ -com		
76	PWIC SVR	O	Power IC discharge circuit control		H: ON, L: OFF
77	PWIC MUTE	O	Power IC mute control		
78	PWIC STBY	O	Power IC standby control		
79	LINE MUTE	I	Line mute detection		TEL mute: Below 1V, NAVI mute: Over 2.5V
80	PWIC DC DET	I	DC offset detection		
81	IC2 SDA	I/O	I2C data input/output		
82	IC2 SCL	I/O	I2C clock input/output		

MICROCOMPUTER'S TERMINAL DESCRIPTION

Pin No.	Pin Name	I/O	Application	Truth Value Table	Processing / Operation / Description
83,84	NC	-	Not used		Output L fixed
85	MUTE 0	O	E-VOL front mute		L: ON, H: OFF
86	MUTE 1	O	E-VOL rear mute		L: ON, H: OFF
87	MUTE 2	O	E-VOL SW mute		L: ON, H: OFF
88	MUTE PRE FR	O	PRE-OUT mute for FR		Mute is L during CD play: L Momentary power down: L Only condition when DUAL ZONE or NAVI INT: H fixed
89	MUTE PRE SW	O	PRE-OUT mute for SW		L: Mute ON, H: Mute OFF
90	RDS NOISE	I	FM noise detection		
91	TUN SMETER	I	S-meter input		
92	LX MUTE	I	Communication request from slave unit		H: Mute ON, L: Mute OFF
93	LX CON	O	Start-up request to slave unit		H: Slave unit ON, L: Slave unit OFF
94	AVSS	-			
95	LX RST	O	Forced reset to slave unit		H: Reset, L: Normal condition
96	VREF	-			
97	AVCC	-			
98	LX DATA S	I	Data from slave unit		
99	LX DATA M	O	Data to slave unit		
100	LX CLK	I/O	LX-BUS clock		

Truth value table

① CD motor control

	CD MOTOR (Pin53)	CD LOEJ (Pin52)
Stop	L	L
Load	H	L
Eject	H	H
Brake	H	Hi-z

TEST MODE

■ Example

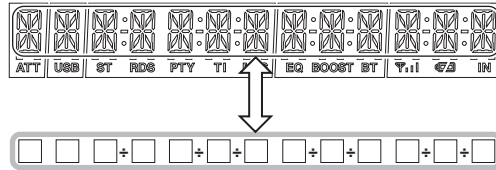

Key	Description of display	Description
5	Disc EJECT times display	Disc EJECT times display. MAX 65535 (times)
■5		While disc EJECT times is displayed, press and hold for 2 seconds or longer to clear disc EJECT times.

A symbol “■” in the key column indicates that the key should be pressed and held for 1 second or longer.

■ How to enter the test mode

Procedure	Note
Press and hold the [1] key and [3] key and reset.	While “- - - -” is displayed, power can be turned ON for only 30 minutes.

All lamps blink when it is detected that the sub-clock resonator is disconnected.

Do not display “CODE_OFF”, “CODE_ON” or “CODE_NG” when Power is ON.

When having started up in the test mode, change the LINE MUTE inhibition time from 10 seconds to 1 second.

When operating in the test mode, even if a DC offset error occurs, detection information is not written in the E2PROM.

When operating in the test mode, CD mechanism error log information clear mode, and DC offset error detection information clear mode, do not perform DEMO mode operations.

Also, do not display DEMO ON/OFF option items in the MENU in STANDBY source in the above modes.

Forced load operation is prohibited in the test mode.

■ How to clear the test mode

Procedure	Note
Reset, momentary power down, ACC OFF, Power OFF, Panel detached.	Clearing the test mode

■ Test mode default condition

Description	Default values
Source	STANDBY
Display	Display lights are all turned on.
Volume	-10dB (“30” is displayed.)
Loudness	OFF
CRSC	OFF regardless of having/not having the switching function.
AUX	ON
System Q	NATURAL (FLAT)
Preout	Rear

TEST MODE

■ Special displays when all lights are on in STANDBY source

Key	Description of display	Description	
Common	All lights ON. □ □ □ ÷ □ □ ÷ □ □ ÷ □ □ ÷ □ □	All lights ON.	
1	Destination terminal condition indication T Y P E 2 : 1 □ T Y P E 1 : 1	“TYPE” indicates system μ-com (IC1) destination, and shows real-time condition of the destination terminal.	
	Development ID condition indication C 0 7 4 7 W E 2 □ - 3 . 0 0	Development ID – Version (system μ-com: IC1)	
2	Serial No. display S N O □ □ 0 0 0 0 0 0 0 0	Serial No. is displayed (8 digits)	
3	Power ON time display	P O N T I M □ □ □ 0 H X X	00~50 is displayed for “XX”. When less than 1 hour, displayed by increments of 10 minutes.
		P O N T I M □ □ X X X X X X	00001~10922 is displayed for “XXXXX”. MAX 10922 (hours)
■3		When Power ON time is displayed, press and hold for 2 seconds or longer to clear Power ON time.	
4	Disc operation time display	C D T I M □ □ □ □ 0 H X X	00~50 is displayed for “XX”. When less than 1 hour, displayed by increments of 10 minutes.
		C D T I M □ □ □ X X X X X X	00001~10922 is displayed for “XXXXX”. MAX 10922 (hours)
■4		While the disc operation time is displayed, press and hold for 2 seconds or longer to clear the disc operation time. (Cleared only for displayed media.)	
5	Disc EJECT times display	E J E C T □ □ X X X X X X	Disc EJECT times display. MAX 65535 (times)
■5			While disc EJECT times is displayed, press and hold for 2 seconds or longer to clear disc EJECT times.
6	Panel open/close times display	P N C N T □ □ □ X X X X X X	PANEL open/close times display. MAX 65535 (times)
■6			Press the key for more than 2 seconds while the PANEL open/close count is displayed and PANEL open/close count is cleared.
FM	ROM correction version display	System μ-com Mecha μ-com S : R 0 0 0 1 M : R 0 0 0 1	The number is the ROM correction version number.
		S : E R R □ □ M : E R R □ □	When E2PROM is not installed.
		S : R - - - M : R - - -	When not written in yet.
		S : R * * * * M : R * * * *	When data not matched. (due to the difference in versions)
▶▶	Audio data initialization	A U D I O □ I N I T □ □ □	AUDIO setting value is re-set to the test mode default value.
◀◀	Forced Power OFF information display	P O F F □ - - □ □ □ □ □	No forced power OFF
		P O F F □ S E C □ □ □ □ □	Forced power OFF because of missing Security Code.
		P O F F □ P N L □ □ □ □ □	Forced power OFF by communication error between system μ-com and panel.
■◀◀			While the forced power OFF data is displayed, press and hold for 2 seconds to clear the data.
▶▶	CD information display mode ON/OFF	□ □ □ □ □ □ □ □ □ □ □ □	For the display contents, refer to “CD information display mode” in the next section.
			While in CD information display mode, press and hold for 2 seconds or longer to clear all CD information.
AUD	Information display iPod authentication IC installation status display	□ i P o d : O K □ □ □ □ □ □	iPod authentication IC installation status display OK: The IC is installed, NG: The IC is not installed.
		□ i P o d : N G □ □ □ □ □ □	(When key is pressed while the display in the left is being shown, returns to normal display.)

TEST MODE

• CD information display mode

Key	Description of display	Description
FM (forward rotation) AM (reverse rotation)	◀◀/ ▶▶ CD mechanism error log display	M E C H A □ E R R 1 □ : X X Mechanism error log 1 (Latest) XX: Error number. "--" is displayed in case there is no error.
		M E C H A □ E R R 2 □ : X X Mechanism error log 2 (Latest) XX: Error number. "--" is displayed in case there is no error.
		M E C H A □ E R R 3 □ : X X Mechanism error log 3 (Latest) XX: Error number. "--" is displayed in case there is no error.
	◀◀/ ▶▶ CD Load error information display	L O A D □ □ E R R 1 □ : X X Load error switch 1 XX: Number of errors. "--" is displayed in case there is no error.
		L O A D □ □ E R R 2 □ : X X Load error switch 2 XX: Number of errors. "--" is displayed in case there is no error.
	◀◀/ ▶▶ CD Ejection error information display	E J E C T □ E R R 1 □ : X X Ejection error switch 1 XX: Number of errors. "--" is displayed in case there is no error.
		E J E C T □ E R R 2 □ : X X Ejection error switch 2 XX: Number of errors. "--" is displayed in case there is no error.
		E J E C T □ E R R 3 □ : X X Ejection error switch 3 XX: Number of errors. "--" is displayed in case there is no error.
		E J E C T □ E R R 4 □ : X X Ejection error switch 4 XX: Number of errors. "--" is displayed in case there is no error.
	◀◀/ ▶▶ CD time code error count data display (Missing counts)	C N T □ L O S E □ □ □ □ □ CD time code error count data (Missing counts) mode display.
		C D D A □ □ □ □ □ □ □ : X X Number of CD-DA count errors XX: Number of errors. "--" is displayed in case there is no error.
		C D R O M □ □ □ □ □ □ □ : X X CD-ROM (Compressed file) number of count errors XX: Number of errors. "--" is displayed in case there is no error.
◀◀/ ▶▶ CD time code error count data display (count not updated)	C N T □ S T A Y □ □ □ □ □ CD time code error count data (count not updated) mode display.	
	C D D A □ □ □ □ □ □ □ : X X Number of CD-DA count errors XX: Number of errors. "--" is displayed in case there is no error.	
	C D R O M □ □ □ □ □ □ □ : X X CD-ROM (Compressed file) Number of count errors XX: Number of errors. "--" is displayed in case there is no error.	

TEST MODE

■ Test mode specifications in TUNER source

Error is found in front-end (A1), etc. if indications below is displayed while in tuner source.

Status	Display	Description
Front-end (A1) E2PROM data error	T N E 2 P N G	Front-end (A1) E2PROM is still the default (unspecified) value.
Front-end (A1) communication error	T N C O N N G	Communication with front-end (A1) is not possible.
Destination mismatch	T N T Y P N G	When destination is mismatch between front-end (A1) E2PROM and the product.

• TUNER preset operation

Key	Description of display	Description
4	Preset function F M # 9 8 . 3 A : 4	Change to 98.3MHz with the preset key [4].

• K3I forced switching

Every time when [6] key is pressed in tuner FM source, switched in the following order: AUTO → Forced WIDE → Forced MIDDLE → Forced NARROW → AUTO. Default status is AUTO, and displayed as shown below.

Key	Description of display	Description
6	K3I Forced switching F M 1 9 8 . 1 A :	AUTO
	F M 1 9 8 . 1 W :	Forced WIDE
	F M 1 9 8 . 1 M :	Forced MIDDLE
	F M 1 9 8 . 1 N :	Forced NARROW

• RDS auto measurement (KDC-W5xxx only)

Add the process to replace the visual inspection of PS display previously done in the production line.

Status	Display	Description
PS data reception	F M 1 R D S T E S T :	If displayed as shown at the left, force to OFF. P-CON is recovered by Power OFF/ON.

• FST adjustment mode

Perform FST soft-mute adjustment.

Key	Note
■▶▶	Enter the FST adjustment mode. (Press for 1 second or longer.)

Operations in the FST adjustment mode are as follows:

Key	Description of display	Description
FM (UP) AM (DOWN)	◀◀/▶▶ Soft-mute adjustment S M D - F	0 ↔ 7
	▶▶/◀◀ Seek Stop Level adjustment (Auto) A T N V	0.00 (V) ↔ 5.00 (V). Normal (Local OFF)
	▶▶/◀◀ Seek Stop Level adjustment (Auto) A T L V	0.00 (V) ↔ 5.00 (V). Normal (Local ON)
	◀◀/▶▶ Seek Stop Level adjustment (Manual) M N N V	0.00 (V) ↔ 5.00 (V). Normal (Local OFF)
	◀◀/▶▶ Seek Stop Level adjustment (Manual) M N L V	0.00 (V) ↔ 5.00 (V). Normal (Local ON)

TEST MODE

Key	Description of display		Description
■▶II	Adjustment value memory	E P <input type="checkbox"/> W R I T E <input type="checkbox"/> <input type="checkbox"/> <input type="checkbox"/> <input type="checkbox"/> <input type="checkbox"/>	Displays the data that has been written in the E2PROM when pressing the key for 2 seconds or longer.
▶II	Mode clear	F M 1 <input type="checkbox"/> <input type="checkbox"/> <input type="checkbox"/> <input type="checkbox"/> 9 8 . 3 A <input type="checkbox"/> : 4	Clear the FST adjustment mode. (Returns to normal display and the test mode is retained.)

Switch Local Seek ON or OFF by briefly pressing [AUTO]/[TI] key when the Local Seek ON/OFF switching is allowed in the band.

After completing the FST adjustment, if you wish to clear the test mode, you can do this using the reset button.

■ Test mode specifications in CD source

Display mode default: P-Time

• Procedure in CD-DA media (KTD-02A)

Key	Description of display		Description
▶▶I	Track up procedure		Every time pressed, jumps to the track shown below. No.9 → No.15 → No.10 → No.11 → No.12 → No.13 → No.22 → No.14 → No.9 (recursive) But in case the disc has 8 tracks or less, playback starts with track No.1. (For both CD-DA and compressed file discs)
I◀◀	Track down procedure		Goes down by 1 track from the currently played track.
1	Jump procedure		Jump to No. 28 (Scratch 0.7mm for MUSIC line vibration testing)
2	Jump procedure		Jump to No. 14 (Blurring surface disc TCD-731RA Tr14)
3	Information display Mechanism model name Mechanism version	<input type="checkbox"/> 6 E 2 0 : <input type="checkbox"/> <input type="checkbox"/> <input type="checkbox"/> <input type="checkbox"/> <input type="checkbox"/> <input type="checkbox"/> <input type="checkbox"/> <input type="checkbox"/>	Display of Mechanism model name and Mechanism version. (When key is pressed while the display in the left is being shown, returns to servo version display.)
	Information display Mechanism servo version	<input type="checkbox"/> S E R V : <input type="checkbox"/> <input type="checkbox"/> <input type="checkbox"/> <input type="checkbox"/> <input type="checkbox"/> <input type="checkbox"/> <input type="checkbox"/> <input type="checkbox"/>	Display of Mechanism model name and Mechanism version. (When key is pressed while the display in the left is being shown, returns to mechanism boot program version display.)
	Information display Mechanism boot program version	<input type="checkbox"/> B O O T : <input type="checkbox"/> <input type="checkbox"/> <input type="checkbox"/> <input type="checkbox"/> <input type="checkbox"/> <input type="checkbox"/> <input type="checkbox"/> <input type="checkbox"/>	Display of Mechanism model name and Mechanism version. (When key is pressed while the display in the left is being shown, returns to normal display.)
6	Jump procedure		Jump to No. 15. Set the volume value to "25". (For 20Hz 0dB DC protection false-operation FCT checking)

• Procedure in CD-DA media (MP3/WMA/AAC)

Key	Description of display		Description
	File type display (MP3)	M P 3 <input type="checkbox"/> <input type="checkbox"/> <input type="checkbox"/> <input type="checkbox"/> <input type="checkbox"/> <input type="checkbox"/> <input type="checkbox"/> <input type="checkbox"/> <input type="checkbox"/> <input type="checkbox"/>	Display file format just before the start of file playback.
	File type display (WMA)	W M A <input type="checkbox"/> <input type="checkbox"/> <input type="checkbox"/> <input type="checkbox"/> <input type="checkbox"/> <input type="checkbox"/> <input type="checkbox"/> <input type="checkbox"/> <input type="checkbox"/> <input type="checkbox"/>	
	File type display (AAC)	A A C <input type="checkbox"/> <input type="checkbox"/> <input type="checkbox"/> <input type="checkbox"/> <input type="checkbox"/> <input type="checkbox"/> <input type="checkbox"/> <input type="checkbox"/> <input type="checkbox"/> <input type="checkbox"/>	

TEST MODE

■ Audio-related test mode

Procedure	Note
Press the [AUD] key (main unit) Press the [AUD] and [*] keys (Remote control)	Enter audio adjustment mode (the initial item should be Fader, and then, Balance → Bass Level → Middle Level → Treble Level → SW Level → System Q → HPF Front → HPF Rear → LPF Sub Woofer). (Then after, any adjustment can be done.)

About audio adjustment items (include both Audio Function Mode and Audio Setup Mode)

Procedure	Item	Procedure	Description
For item forwarding procedure, press [AUD] key and [FM] key	Fader	[VOL] knob and [◀◀ / ▶▶] key	Adjust to 3 steps of R15 ↔ 0 ↔ F15. (Default value: 0)
	Balance	[VOL] knob and [◀◀ / ▶▶] key	Adjust to 3 steps of L15 ↔ 0 ↔ R15. (Default value: 0)
	Bass Level	[VOL] knob and [◀◀ / ▶▶] key	Adjust to 3 steps of -8 ↔ 0 ↔ +8. (Default value 0)
	Middle Level	[VOL] knob and [◀◀ / ▶▶] key	Adjust to 3 steps of -8 ↔ 0 ↔ +8. (Default value 0)
	Treble Level	[VOL] knob and [◀◀ / ▶▶] key	Adjust to 3 steps of -8 ↔ 0 ↔ +8. (Default value 0)
	HPF Front	[VOL] knob and [◀◀ / ▶▶] key	Adjust to 2 steps of Through ↔ 180Hz. (Default value: Through)
	HPF Rear	[VOL] knob and [◀◀ / ▶▶] key	Adjust to 2 steps of Through ↔ 180Hz. (Default value: Through)
	LPF Sub woofer	[VOL] knob and [◀◀ / ▶▶] key	Adjust to 2 steps of 60Hz ↔ Through. (Default value: Through)
	LPF Subwoofer Phase	[VOL] knob and [◀◀ / ▶▶] key	Adjust to 2 steps of Normal ↔ Reverse. (Default value: Normal)
	Volume Offset	[VOL] knob and [◀◀ / ▶▶] key	Adjust to 2 steps of -8 ↔ 0. (Default value 0)
	Loudness	[VOL] knob and [◀◀ / ▶▶] key	Adjust to 2 steps of OFF ↔ ON. (Default value OFF)
	Dual Zone	[VOL] knob and [◀◀ / ▶▶] key	Adjust to 2 steps of OFF ↔ ON. (Default value OFF)

■ MENU-related test mode

Procedure	Note
Press the [M.JOG] key (main unit) Press the [DNPP/SBF] and [DIRECT] keys (Remote control)	Continuous forwarding by remote control is prohibited

■ Backup current measurement

Procedure	Note
While ACC OFF (Back Up ON), Reset	MUTE terminal is OFF after 2 seconds, not after 15 seconds. (During this time, the CD mechanism does not function.)

■ PREOUT switching

Procedure	Note
In the STANDBY source, press and hold [AUTO] key for 1 second or longer	Switches PREOUT

■ Dual Zone switching

Procedure	Note
In the except STANDBY source, press the [AUTO] key.	Switches ZONE2 ON/OFF. (Default OFF)

TEST MODE

■ Clearing CD mechanism information / Service information / DC offset error information (Clearing E2PROM data)

Status	Display	Description
While pressing and holding [2] key and [5] key, reset-start.	[C] [D] [] [O] [] [] [] [] [] [] [] [] [] [] []	At normal termination
	[C] [D] [] [X] [] [] [] [] [] [] [] [] [] [] []	At abnormal termination

While “---” is displayed, power can be ON for 30 minutes. This mode is cancelled by resetting. (The last screen will not be retained.)
Data to be cleared is shown below.

CD mechanism information	CD mechanism error log display
	Displays CD loading error data
	Displays CD EJECT error data
	Displays CD time code count error data (missing count)
	Displays CD time code count error data (count not updated)
Service Information	Power ON time display
	CD operation time display
	CD EJECT times display
	PANEL open/close times display
	Forced Power OFF information display
DC offset error information	DC offset error 1 display (Provides information on whether there is an improper connection or another error)
	DC offset error 2 display (Provides information on the number of capacitor leaks)

■ Clearing DC offset error detection data (E2PROM data clearing)

Procedure	Note
While pressing and holding [3] key and [6] key, reset-start.	Entering DC offset error display mode.

Procedure	Display	Description
Press and hold the [3] and [6] keys, and reset-start	[D] [C] [] [] [E] [R] [R] [] [] [] [] [] [] [] [] []	When DC offset error is detected (when either one of capacitors is leaking, or an improper connection or another error is detected)
	[D] [C] [] [] [O] [K] [] [] [] [] [] [] [] [] [] []	When DC offset error is not detected (when none of capacitors leak, no improper connection or other error is detected)
1	[D] [C] [1] [] [E] [R] [R] [] [] [] [] [] [] [] [] []	When improper connection or other DC offset errors are detected.
	[D] [C] [1] [] [O] [K] [] [] [] [] [] [] [] [] [] []	When improper connection or other DC offset errors are not detected.
■1	[D] [C] [1] [] [O] [K] [] [] [] [] [] [] [] [] [] []	When detecting improper connection or other DC offset errors, clears detection data. (Clear E2PROM)
2	[D] [C] [2] [] [4] [] [] [] [] [] [] [] [] [] [] []	When detecting capacitor leak, provides information on the number of capacitor leaks. (0~4)
■2	[D] [C] [2] [] [0] [] [] [] [] [] [] [] [] [] [] []	When detecting capacitor leak, clears the number of capacitor leaks. (Clear E2PROM)

This mode is cancelled by resetting. (The last screen will not be retained.)

■ FM/AM channel space switching (KDC-MPxxx and KDC-X492 only)

Procedure	Note
While Power OFF, press and hold [1] key and [5] key, and press [SRC] key to Power ON	FM200kHz/AM10kHz ↔ FM50kHz/AM9kHz FM50kHz/AM10kHz ↔ FM200kHz/AM10kHz (KDC-MP408U)

TEST MODE

■ Security

• Forced Power ON mode

Procedure	Note
While pressing and holding [M.JOG] key and [4] key, reset-start.	While “- - -” is displayed, power can be turned ON for only 30 minutes. After 30 minutes, can only be recovered by resetting.

• How to register the security code on the “Car Audio Passport” after replacement of the FRONT-END (A1) with E2PROM (Models for destination “M” and “E”)

Procedure	Description
While pressing and holding [1] key and [3] key, reset-start	Enters the test mode
Press the [M.JOG] key	Enters the MENU mode.
Press and hold [▶▶] key for 1 second or longer	Enters the security registration mode.
[FM] / [AM] / [◀◀ / ▶▶] key	Inputs the code. FM: Number up / AM: Number down / ◀◀: Cursor to the left / ▶▶: Cursor to the right
Press and hold [▶▶] key for 3 seconds or longer	“RE-ENTER” is displayed.
[FM] / [AM] / [◀◀ / ▶▶] key	Inputs the code again. FM: Number up / AM: Number down / ◀◀: Cursor to the left / ▶▶: Cursor to the right
Press and hold [▶▶] key for 3 seconds or longer	“APPROVED” is displayed.
Reset, momentary power down, ACC OFF, Power OFF, panel removed	Cancels the test mode.

Note: The security code in this model cannot be all-clear.

• Method of clearing the programmable security code (Models for destination “K”)

Procedure	Display	Description
Press [▶▶] key for 3 seconds or longer-while pressing [AUTO] key	C O D E □ - - - □ □ □ □ □ □ □ □	Carry out the procedure while “- - - -” is being displayed.
	C O D E □ □ □ □ □ □ □ □ □ □ □ □	“- - - -” disappears.
Press the remote control [5] key 2 times, display “K”, and press [▶▶] key.	C O D E □ K □ □ □ □ □ □ □ □ □ □	
Press the remote control [2] key 3 times, display “C”, and press [▶▶] key.	C O D E □ K C □ □ □ □ □ □ □ □ □ □	
Press the remote control [2] key 1 time, display “A”, and press [▶▶] key.	C O D E □ K C A □ □ □ □ □ □ □ □ □ □	
Press the remote control [7] key 2 times, display “R”, and press [▶▶] key.	C O D E □ K C A R □ □ □ □ □ □ □ □ □ □	
	A P P R O V E D □ □ □ □ □ □ □ □ □ □	Security cancelled. (If wrong character is input, code request mode is displayed.)

TEST MODE

■ ROM data transfer

When replacing front-end (A1), this function is used to transfer E2PROM data (ROM correction, security and other data) to front-end (A1) to E2PROM of to mother unit (X34-), used for saving data, and, after completing replacement of front-end (A1), to recover data from the E2PROM of the mother unit (X34-), and for saving data to the new front-end (A1). Refer to “ROM data transfer processes” on the next page for details on front-end (A1) replacement procedures and on the data to be transferred.

Procedure	Display	Description
While pressing and holding [1] key and [3] keys, reset-start	□ □ □ □ □ □ □ □ □ □ □ □ □ □	All lights ON.
Press [M.JOG] key (MENU)	R O M □ R E A D □ □ □ □ □ □	MENU mode
Press [◀◀] key or [▶▶] key	R O M □ R E A D □ □ □ □ □ □	Front-end (A1) → Mother unit (X34-). Data transfer processing.
	R O M □ W R I T E □ □ □ □ □ □	Mother unit (X34-) → Front-end (A1). Data transfer processing.
(In the above ROM READ status), ■ [▶▶] key for 2 seconds or longer	R O M □ R E A D □ □ □ □ □ □	Front-end (A1) → Mother unit (X34-). ROM data is being transferred.
	R O M □ R E A D □ □ O K □ □	Front-end (A1) → Mother unit (X34-). ROM correction transfer, security and other data is OK.
	R O M □ R E A D □ □ O K 2 □	Front-end (A1) → Mother unit (X34-). Transfer of security and other data is OK.
	R O M □ R E A D □ □ N G □ □	Front-end (A1) → Mother unit (X34-). ROM data transfer is NG.
(In the above ROM WRT status), ■ [▶▶] key for 2 seconds or longer	R O M □ W R I T E □ □ □ □ □ □	Mother unit (X34-) → Front -end (A1). ROM data is being transferred.
	R O M □ W R I T E □ □ O K □ □	Mother unit (X34-) → Front-end (A1). ROM correction, security and other data transfer is OK.
	R O M □ W R I T E □ □ O K 1 □	Mother unit (X34-) → Front-end (A1). ROM correction data transfer is OK.
	R O M □ W R I T E □ □ O K 2 □	Mother unit (X34-) → Front-end (A1). Transfer of security and other data is OK.
	R O M □ W R I T E □ □ N G □ □	Mother unit (X34-) → Front-end (A1). ROM data transfer is NG
(In every status of ROM data [M.JOG] transfer processing)	□ □ □ □ □ □ □ □ □ □ □ □ □ □	Clear from ROM correction data transfer processing

ROM DATA TRANSFER PROCESSES

When replacing front-end (A1) of mother unit (X34-), or when adding or replacing ROM correction (program correction with ROM IC (IC10)), the following activities are required.

■ Overview

When replacing front-end (A1) in the model where ROM correction and security data have been written into E2PROM, included in the front-end (A1) pack, the transfer function of the E2PROM data itself in the replaced front-end (A1) is required.

This function in the above system configuration is used to allow for complete replacement of the front-end at any service center.

■ Overview of specifications

Procedures for replacement are as follows: To install the E2PROM to the mother unit (X34-), and replace front-end (A1) with new front-end after copying the data in the E2PROM (such as ROM correction data and other data) in the front-end (A1) to the mother unit (X34-) by operating the system, and then copy the data (such as ROM correction data and other data) into the mother unit to the E2PROM of the front-end (A1), operating the main body.

Tuner adjustment data was inserted during the tuner pack manufacturing, and data will not be transferred because front-end (A1) is built-in.

In addition, tuner adjustment data for new front-end (A1) is supplied as a service part in which data was inserted.

■ Data to be copied

- ROM correction data
- Other data
 - Security data
 - DEMO MODE ON/OFF status
 - POWER ON time (For maintenance)
 - Playback time (For maintenance)
 - EJECT count (For maintenance)
 - Panel open/close count (For maintenance)
 - CD I2C status (For maintenance)
 - CD offset error code (For maintenance)
 - CD sound skips count (For maintenance)
 - CD time code not updated count (For maintenance)
 - CD load switch errors count (For maintenance)
 - CD ejection errors count (For maintenance)
 - DC offset error (For maintenance)
 - Forced Power OFF information (For maintenance)
 - Serial number (For maintenance)
 - E2PROM data check data (For internal check)

■ Operation procedure

Operation procedure is different depending on the conditions. Proceed with the appropriate operation procedure depending on the specific condition.

1. In case of replacing front-end (A1) without an applicable ROM correction.
2. In case of replacing front-end (A1) with an applicable ROM correction.
3. In case of applying new ROM correction at the same time when front-end (A1) is replaced. (No ROM correction has been carried out.)

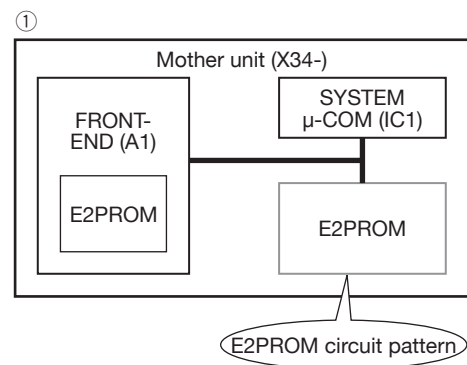

Install new E2PROM.

Install E2PROM containing no data, in case of [1] and [2].

In case of [3], install maintenance E2PROM with an applicable ROM correction program.

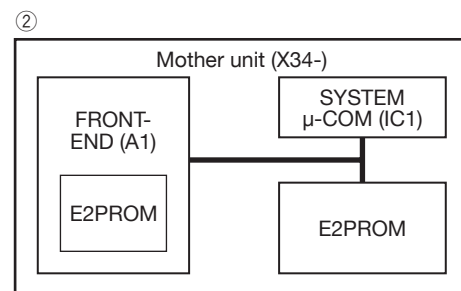

ROM DATA TRANSFER PROCESSES

Turn power on.

Press and hold the [1] and [3] keys and press reset button.
(Enter the system in the test mode.)

Press [B.BOOST] key. (ROM data System enters data transfer mode.)

Press [◀◀] (or ▶▶) . (Select READ)

Press [▶] key for 1 second or longer. (Data transfer)

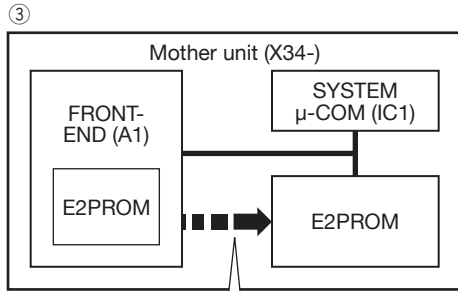

The system μ-COM (IC1) copies the data in the front-end (A1) in the E2PROM on the mother unit (X34-)

In case of [2]

READ OK R-OK

In case of [1] or [3]

READ OK2 R-O2



Press [▶] key. (Exit ROM data transfer mode.)

Turn power off.

Remove front-end (A1).

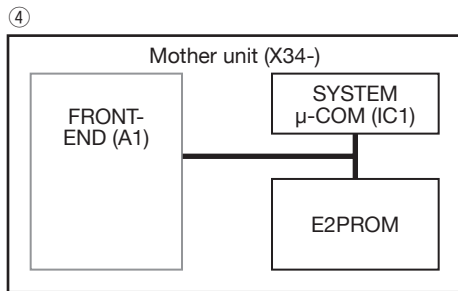

Install new front-end (A1).

No ROM correction or other data status.

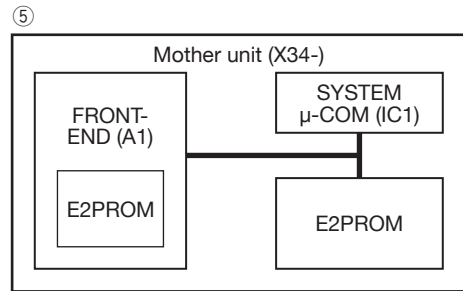

Turn power on.

Press and hold the [1] and [3] keys and press reset button.
(Enter the system in the test mode.)

Press [B.BOOST] key. (Start transferring ROM data.)

Press [◀◀] (or ▶▶) . (Select WRT)

Press [▶] key for 1 second or longer. (Data transfer)

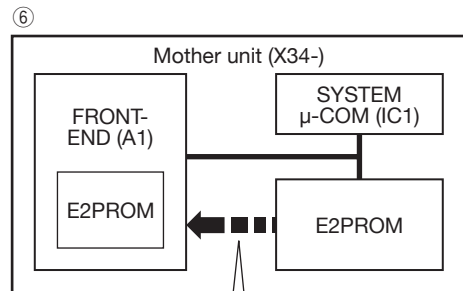

System μ-COM (IC1) copies data on the mother unit (X34-) into E2PROM in the front-end (A1)

In case of [2] or [3]

WRT OK W-OK

In case of [1]

WRT OK2 W-O2

Press [▶] key. (Exit ROM data transfer mode.)

ROM DATA TRANSFER PROCESSES

4. In case of applying a new ROM correction when front-end (A1) is replaced (There is ROM correction data.)
5. In case of applying a new ROM correction even when front-end (A1) is not replaced.

Turn power on.
 Press and hold the [1] and [3] keys, press reset button. (Enter the system in the test mode.)
 Press [B.BOOST] key. (ROM data System enters data transfer mode.)
 Press [◀◀] (or ▶▶) . (Select WRT)
 Press [▶▶] key for 1 second or longer. (Data transfer)

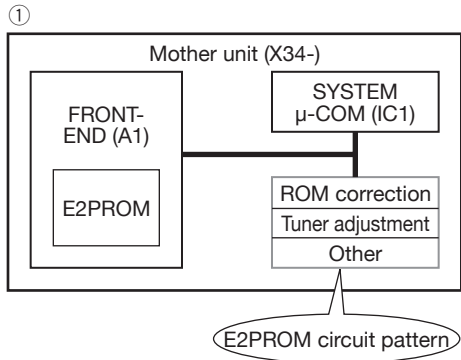

Install new E2PROM. (E2PROM that has been updated with ROM correction)

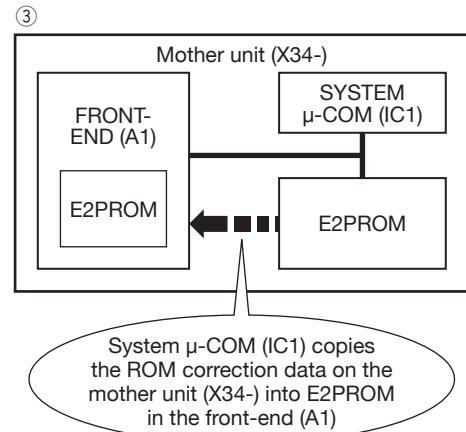
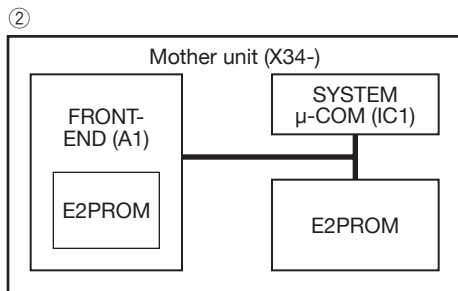

In case of [4] ↓ In case of [5]

Press [▶▶] key. (Exit ROM data transfer mode.)

Press [◀◀] (or ▶▶) . (Select READ)
 Press [▶▶] key for 1 second or longer. (Data transfer)

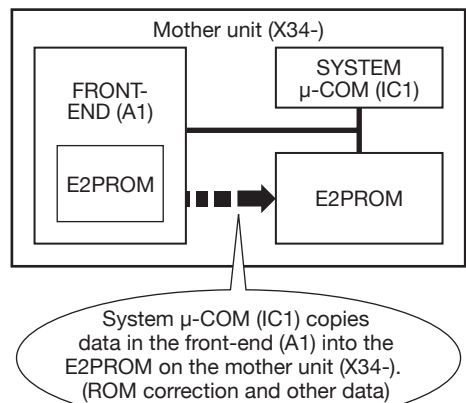

ROM DATA TRANSFER PROCESSES

Press [▶|] key. (Exit ROM data transfer mode.)
Turn power off.

Remove front-end (A1).

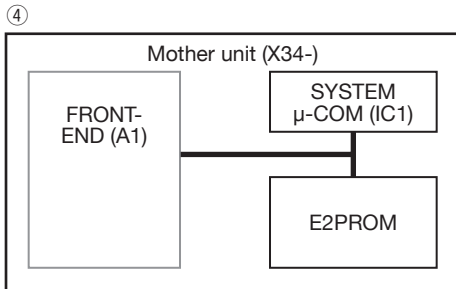

Install new front-end (A1).
No ROM correction or other data status.

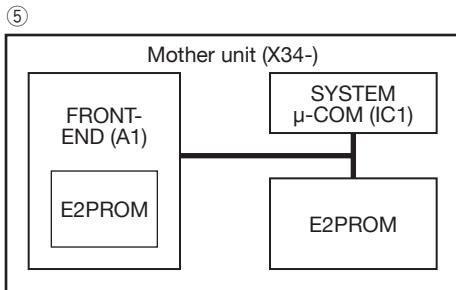

Turn power on.

Press and hold the [1] and [3] keys press reset button. (Enter the system in the test mode.)

Press [B.BOOST] key. (Enter the system in ROM data transfer mode.)

Press [◀◀] (or ▶▶) .) (Select WRT)

Press [▶|] key for 1 second or longer. (Data transfer)

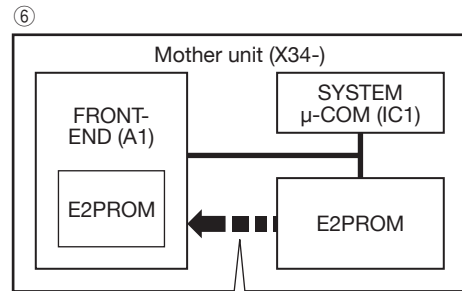

System μ-COM (IC1) copies data on the mother unit (X34-) into E2PROM in the front-end (A1)



Press [▶|] key. (Exit ROM data transfer mode.)

PC BOARD (COMPONENT SIDE VIEW)

ELECTRIC UNIT
X34-577x-xx (J76-0479-12)

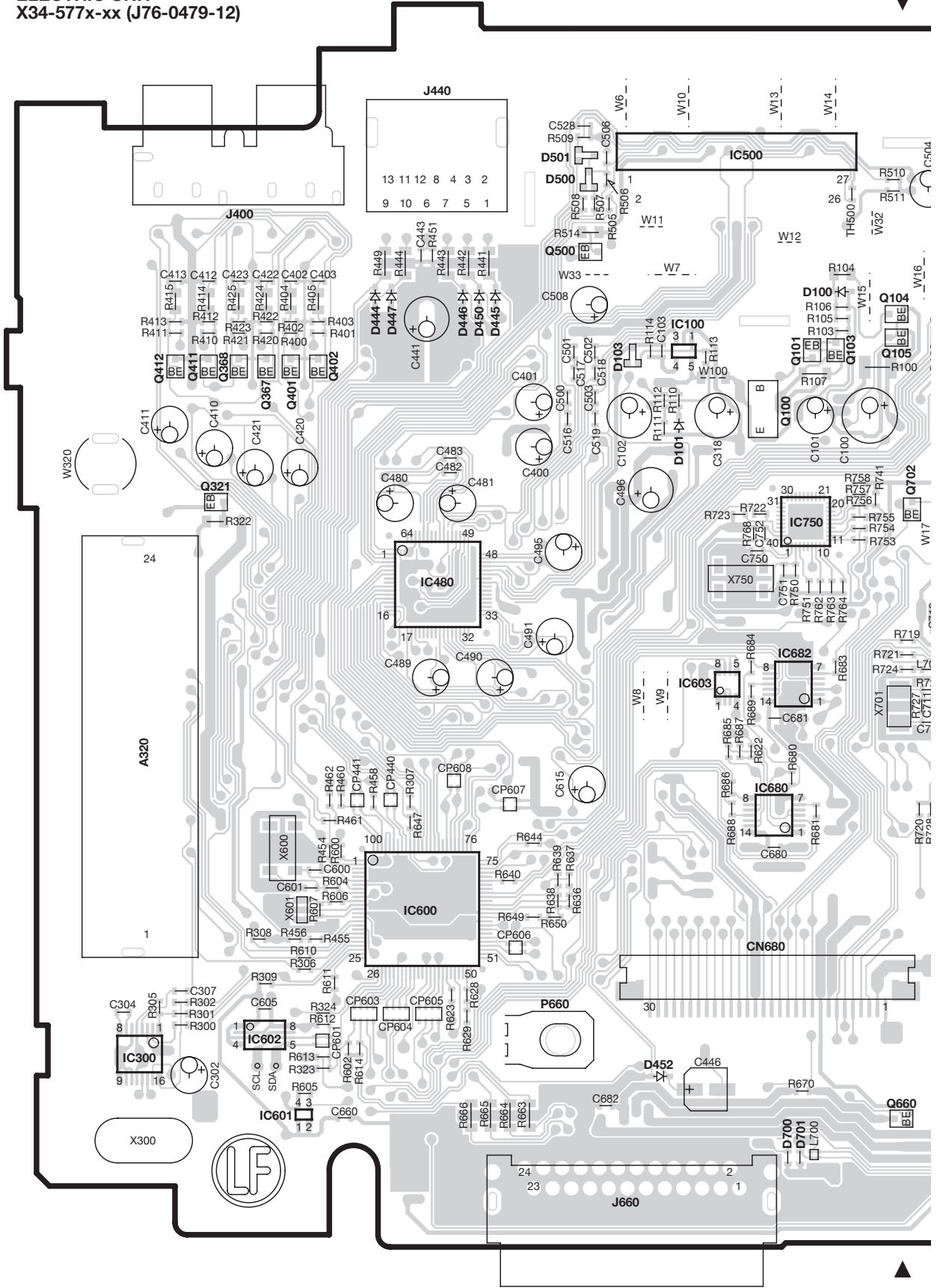

KDC-MP408U/MP438U/X492/MP5039U/MP5539U/W5041UA/
W5041UG/W5141UAY/W5141UGY/W5541U/W5641UY

PC BOARD (COMPONENT SIDE VIEW)

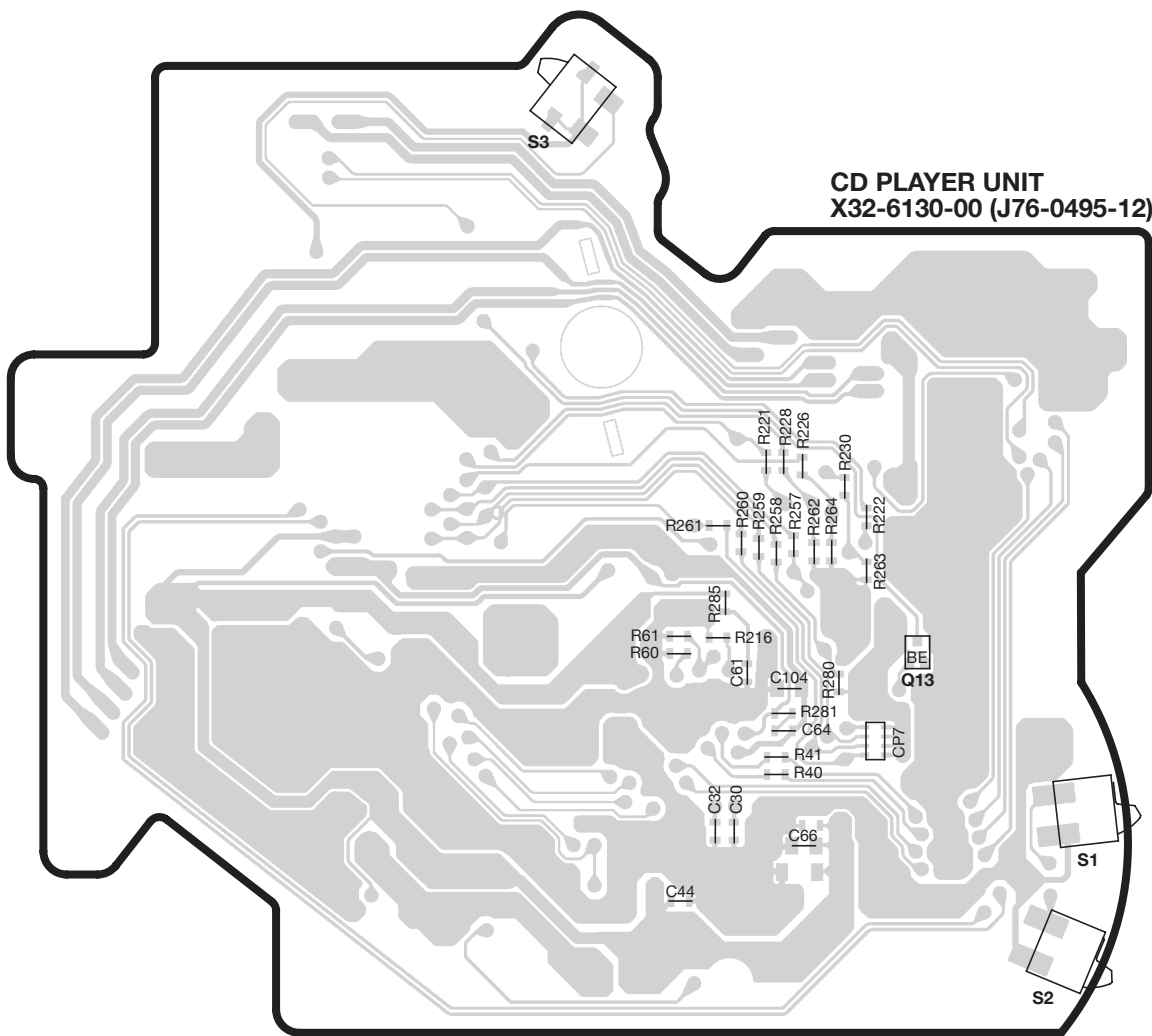

CD PLAYER UNIT
X32-6130-00 (J76-0495-12)

X32-6130-00

Ref. No.	Address
Q13	4AC

Refer to the schematic diagram for the values of resistors and capacitors.

PC BOARD (FOIL SIDE VIEW)

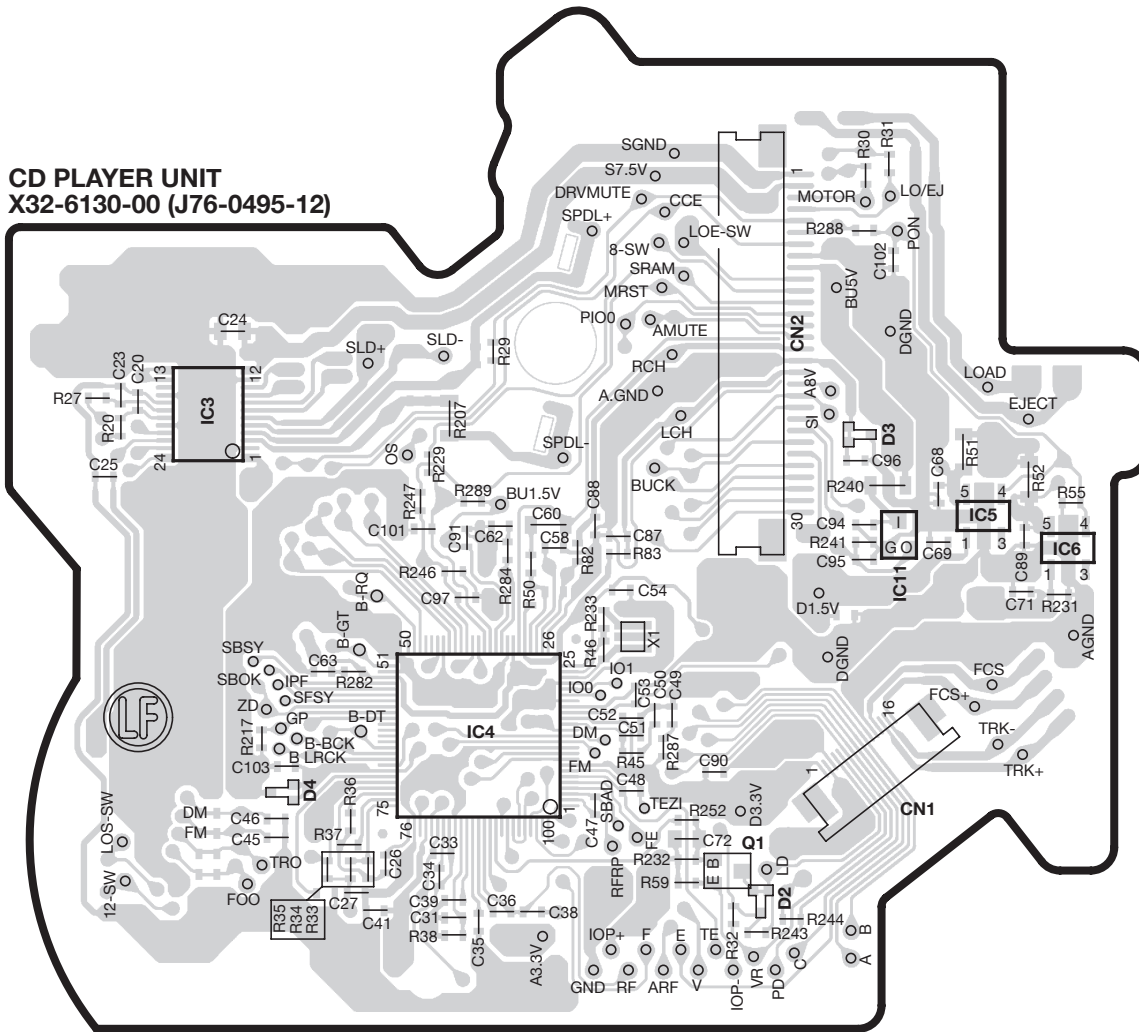

X32-6130-00

Ref. No.	Address
IC3	3AF
IC4	4AF
IC5	3AH
IC6	3AH
IC11	3AH
Q1	4AG

Refer to the schematic diagram for the values of resistors and capacitors.

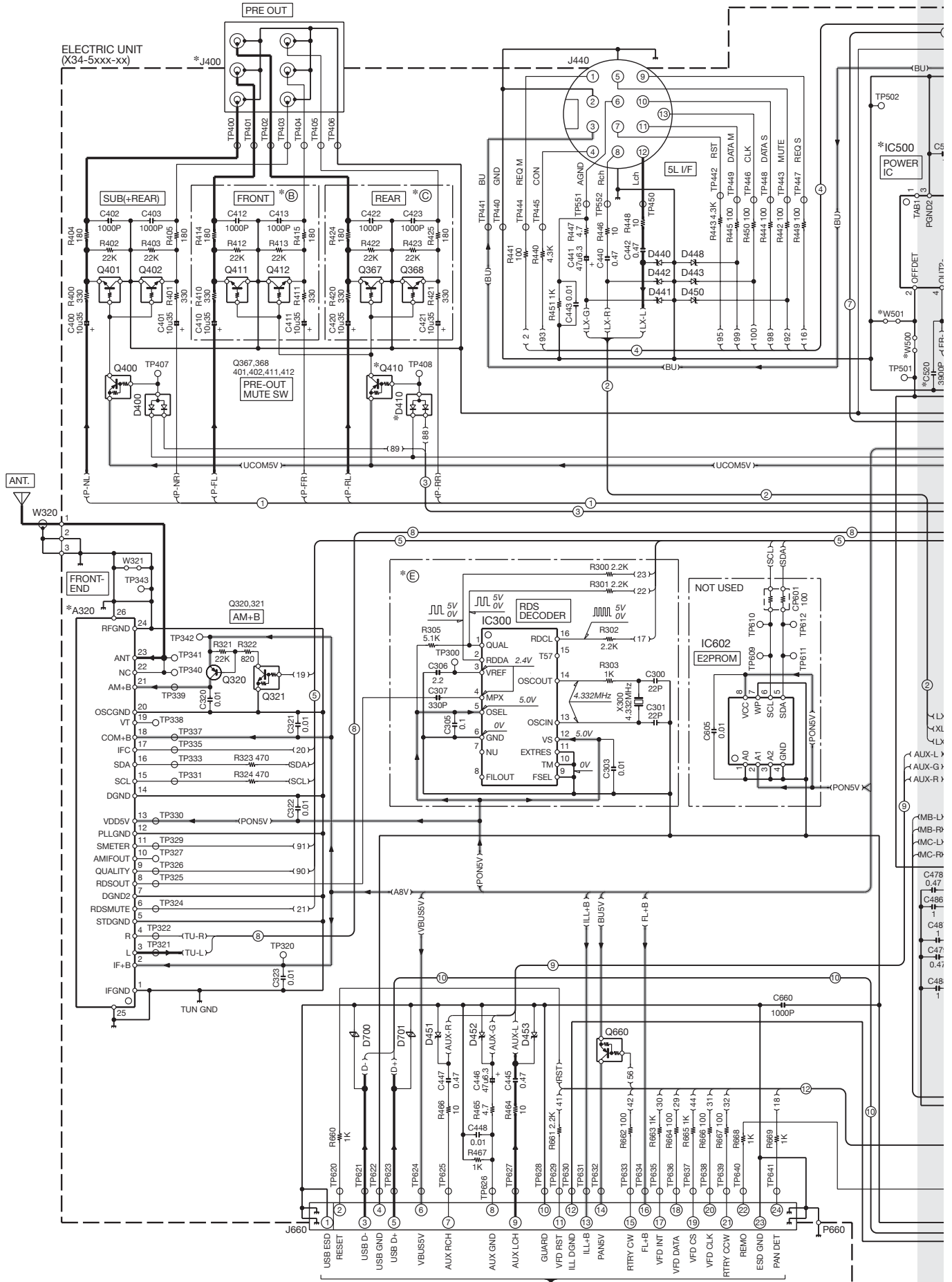

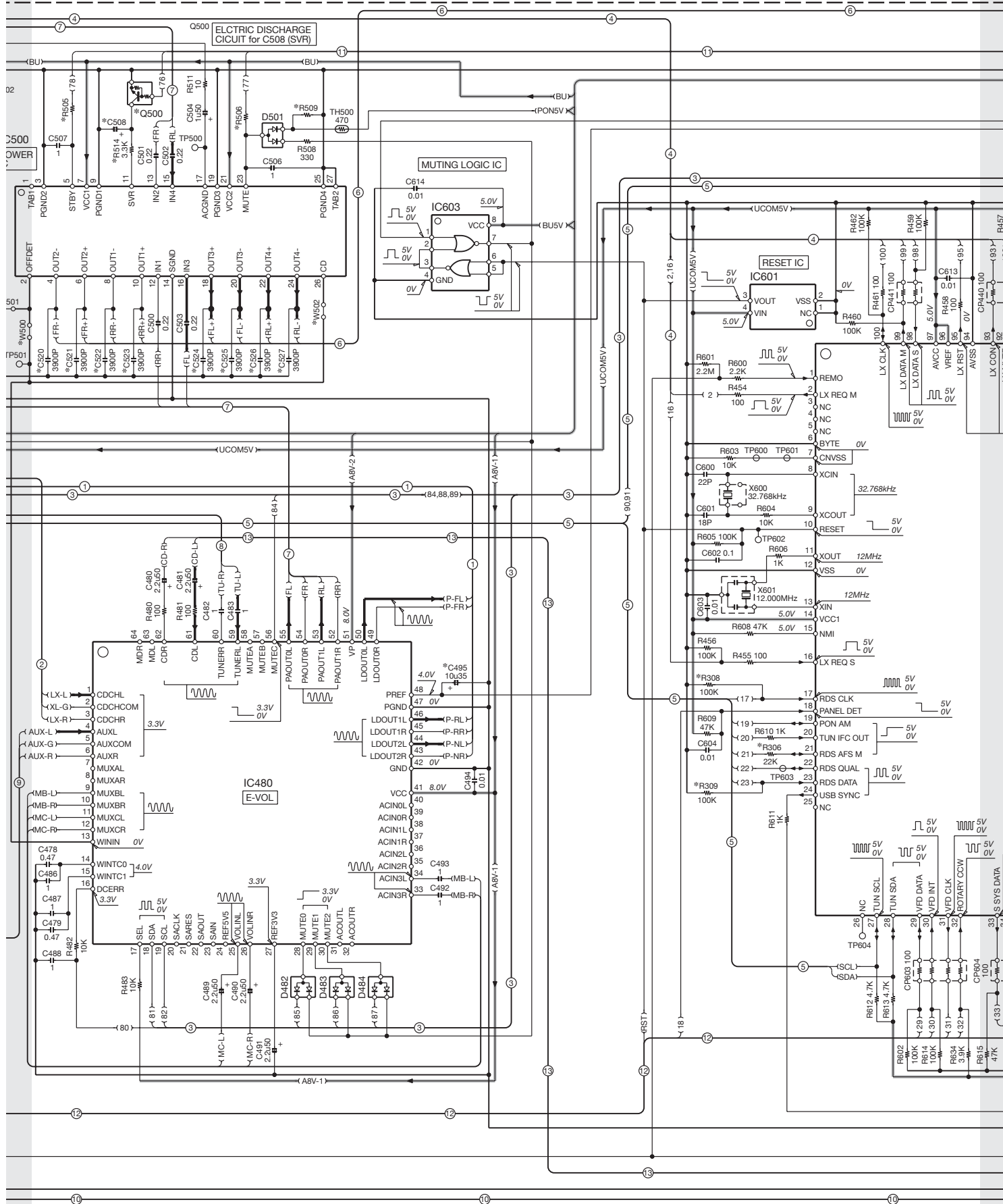

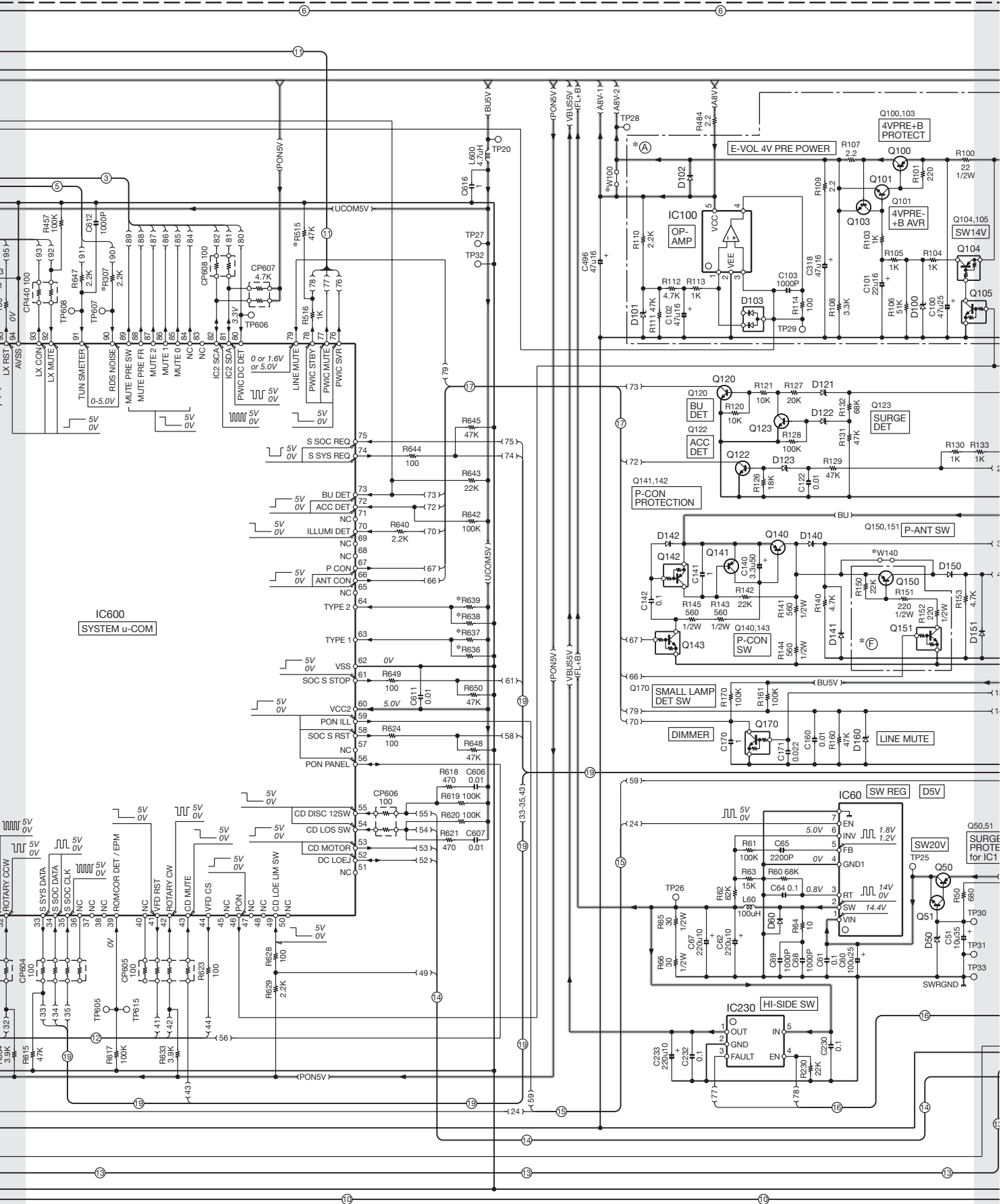

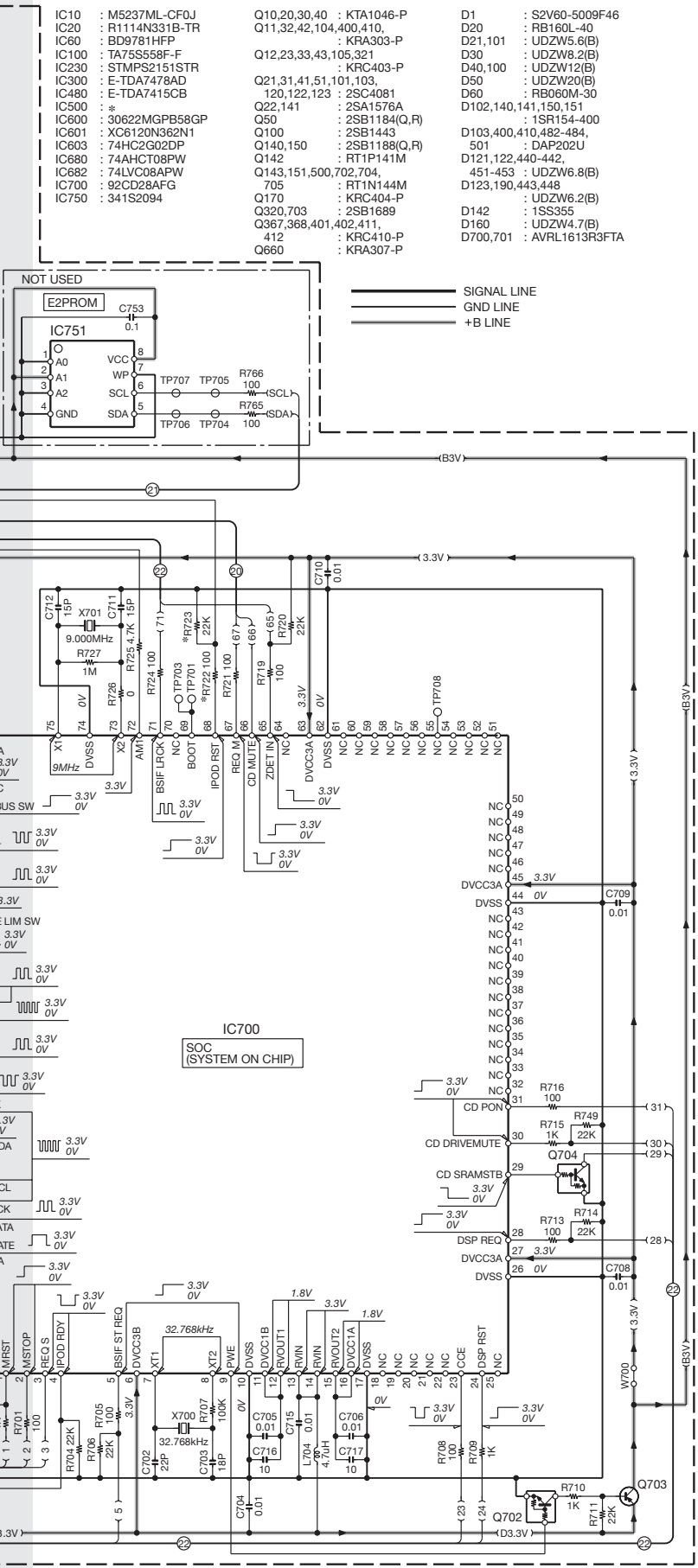

DESTI-NATION	MODEL NAME	UNIT No.	(A)	(B)	(C)	(D)	(E)	(F)	A320	C485	C508	C520	C527	J400	IC500	Q410	Q500	R306-309	R505	R506	R509	R514-515	R636	R637	R638	R722-723	W140	W500	W501-502
US55	KDC-MP408U	X34-5770-01	—	—	—	—	—	—	—	—	—	—	—	—	—	—	—	—	—	—	—	—	—	—	—	—	—	—	—
K3	KDC-MP438U	X34-5770-12	—	—	—	—	—	—	—	—	—	—	—	—	—	—	—	—	—	—	—	—	—	—	—	—	—	—	—
K1	KDC-MP5039U	X34-5770-10	—	—	—	—	—	—	—	—	—	—	—	—	—	—	—	—	—	—	—	—	—	—	—	—	—	—	—
M2	KDC-MP5539U	X34-5770-21	—	—	—	—	—	—	—	—	—	—	—	—	—	—	—	—	—	—	—	—	—	—	—	—	—	—	—
E2/E3	KDC-W5141UAY/UGY	X34-5772-73	—	—	—	—	—	—	—	—	—	—	—	—	—	—	—	—	—	—	—	—	—	—	—	—	—	—	—
E5/E6	KDC-W5541UY	X34-5772-74	—	—	—	—	—	—	—	—	—	—	—	—	—	—	—	—	—	—	—	—	—	—	—	—	—	—	—
E1	KDC-W5641UY	X34-5772-71	—	—	—	—	—	—	—	—	—	—	—	—	—	—	—	—	—	—	—	—	—	—	—	—	—	—	—
E4	KDC-W5641UY	X34-6172-72	—	—	—	—	—	—	—	—	—	—	—	—	—	—	—	—	—	—	—	—	—	—	—	—	—	—	—
VISITEON	SKDCMP4080U	X34-6172-10	—	—	—	—	—	—	—	—	—	—	—	—	—	—	—	—	—	—	—	—	—	—	—	—	—	—	—
TOYOTA	SKDCMP4080U	X34-5770-13	—	—	—	—	—	—	—	—	—	—	—	—	—	—	—	—	—	—	—	—	—	—	—	—	—	—	—

CAUTION : For continued safety, replace safety critical components only with manufacturer's recommended parts (refer to parts list). Δ Indicates safety critical components. To reduce the risk of electric shock, leakage-current or resistance measurements shall be carried out (exposed parts are acceptably insulated from the supply circuit) before the appliance is returned to the customer.

- DC voltages are as measured with a high impedance voltmeter. Values may vary slightly due to variations between individual instruments or/and units.

KDC-MP408U/MP438U/
X492/MP5039U/MP5539U/
W5041UA/W5041UG/
W5141UAY/W5141UGY/
W5541U/W5641UY (1/2)

KDC-MP408U/MP438U/X492/MP5039U/MP5539U/W5041UA/
W5041UG/W5141UAY/W5141UGY/W5541U/W5641UY

1

2

3

4

5

6

7

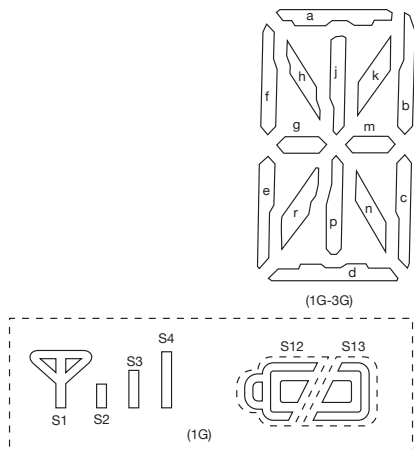

SWITCH UNIT (X16-6xxx-xx)

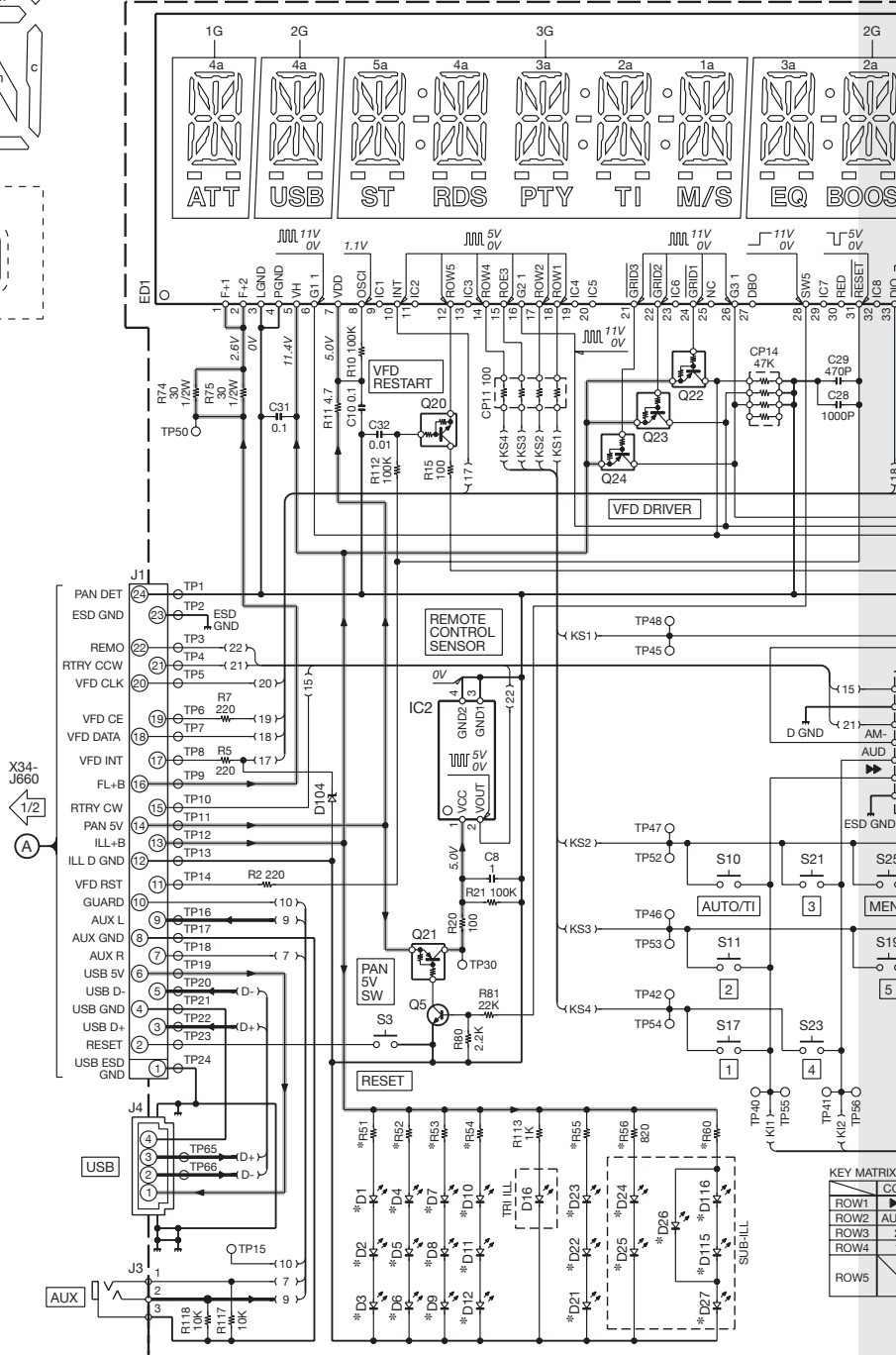

SWITCH UNIT (X16-6xxx-xx)

MODEL NAME	DESTINATION	UNIT No.	D1-12	D21-23	D24-26	D27	D115,116	R51-54	R55	R56	R60
U535	J	X16-6220-01	B30-1782-05	B30-1781-05	—	B30-1781-05	B30-1781-05	560	270	—	270
KDC-MP408U	K3	X16-6220-11	B30-1779-05	B30-1781-05	—	B30-1781-05	B30-1781-05	620	270	—	270
KDC-MP438U	K2	X16-6220-10	B30-1781-05	B30-1781-05	—	B30-1781-05	B30-1781-05	270	270	—	270
KDC-X492	K1	X16-6220-10	B30-1781-05	B30-1781-05	—	B30-1781-05	B30-1781-05	270	270	—	270
KDC-MP5039U	M2	X16-6220-10	B30-1781-05	B30-1781-05	—	B30-1781-05	B30-1781-05	270	270	—	270
KDC-MP5539U	M1	X16-6222-71	B30-1779-05	B30-1779-05	—	B30-1779-05	B30-1779-05	820	820	—	820
KDC-W5041UA	E2	X16-6222-72	B30-1780-05	B30-1780-05	YES	B30-1780-05	B30-1779-05	560	560	YES	820
KDC-W5041UG	E3	X16-6222-71	B30-1779-05	B30-1779-05	—	B30-1779-05	B30-1779-05	620	620	—	620
KDC-W5141UAY	E5	X16-6222-71	B30-1779-05	B30-1779-05	—	B30-1779-05	B30-1781-05	620	270	—	270
KDC-W5141UGY	E6	X16-6222-72	B30-1780-05	B30-1780-05	YES	B30-1780-05	—	560	560	YES	820
KDC-W5541U	E1	X16-6220-10	B30-1781-05	B30-1781-05	—	B30-1781-05	B30-1781-05	270	270	—	270
KDC-W5641UY	E4	X16-6420-10	B30-1779-05	B30-1781-05	—	B30-1781-05	B30-1781-05	620	270	—	270
SKDCMP7090U	VISTEON	X16-6420-10	B30-1779-05	B30-1781-05	—	B30-1781-05	B30-1781-05	620	270	—	270
SKDCMP4008U	TOYOTA	X16-6222-72	B30-1780-05	B30-1780-05	YES	B30-1780-05	—	560	560	YES	820

KDC-MP408U/MP438U/X492/MP5039U/MP5539U/W5041UA/
W5041UG/W5141UAY/W5141UGY/W5541U/W5641UY

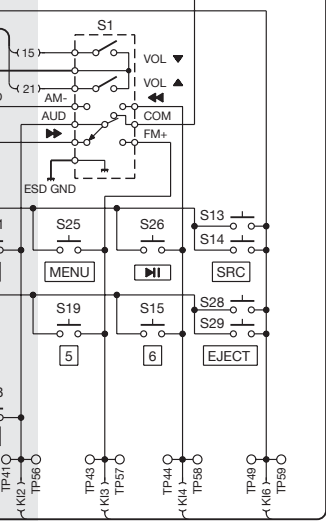
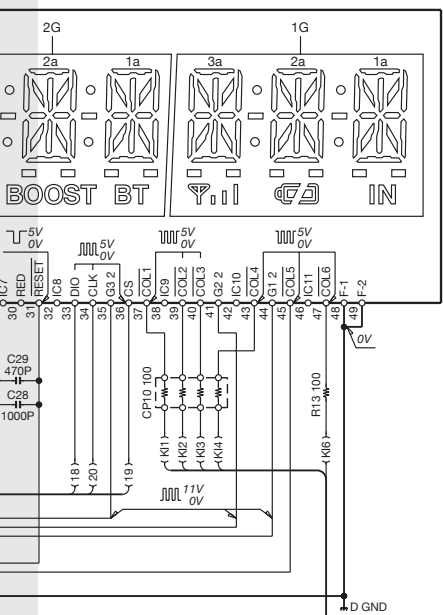

KEY MATRIX (TDF BASIC)

	COL1	COL2	COL3	COL4	COL5	COL6
ROW1	▶▶	AUD	FM	◀◀		AM
ROW2	AUTO	3	MENU	▶▶		SRC
ROW3	2		5	6		EJECT
ROW4	1	4				
ROW5						LOW PANEL DETECT

(FOR 07MODEL)

- KDC-MP408U/MP438U/
X492/MP5039U/MP5539U/
W5041UA/W5041UG/
W5141UAY/W5141UGY/
W5541U/W5641UY (2/2)
- IC2 : PIC95603
 - Q5 : 2SC4617
 - Q20 : RT1N441U
 - Q21 : RT1P141U
 - Q22-24 : DTA123JUA
 - D1-12 : *
 - D16 : B30-1779-05
 - D21-23 : *
 - D24-26 : B30-1780-05
 - D27 : *
 - D104 : UDZW5.6(B)
 - D115,116 : *
- SIGNAL LINE
 GND LINE
 +B LINE

	1G	2G	3G
P1	3a	3a	3a
P2	2a	2a	2a
P3	1a	1a	1a
P4	3h	3h	3h
P5	2h	2h	2h
P6	1h	1h	1h
P7	3j	3j	3j
P8	2j	2j	2j
P9	1j	1j	1j
P10	3k	3k	3k
P11	2k	2k	2k
P12	1k	1k	1k
P13	col3	col3	col3
P14	col1	col1	col1
P15	3b	3b	3b
P16	2b	2b	2b
P17	1b	1b	1b
P18	3f	3f	3f
P19	2f	2f	2f
P20	1f	1f	1f
P21	3m	3m	3m
P22	2m	2m	2m
P23	1m	1m	1m
P24	S6	S8	S10
P25	S5	S7	S9
P26	3g	3g	3g
P27	2g	2g	2g
P28	1g	1g	1g
P29	3c	3c	3c
P30	2c	2c	2c
P31	1c	1c	1c
P32	3e	3e	3e
P33	2e	2e	2e
P34	1e	1e	1e
P35	3r	3r	3r
P36	2r	2r	2r
P37	1r	1r	1r
P38	col4	col4	col4
P39	col2	col2	col2
P40	3p	3p	3p
P41	2p	2p	2p
P42	1p	1p	1p
P43	3n	3n	3n
P44	2n	2n	2n
P45	1n	1n	1n
P46	3d	3d	3d
P47	2d	2d	2d
P48	1d	1d	1d
P49	S1	EQ	ST
P50	S2	BOOST	RDS
P51	S3	BT	PTY
P52	S4	USB	TI
P53	S12	—	M/S
P54	S13	—	col5,6
P55	IN	—	S11
P56	ATT	4d	4d
P57	4d	—	5d
P58	4n	4n	4n
P59	—	—	5n
P60	4p	4p	4p
P61	—	—	5p
P62	4r	4r	4r
P63	—	—	5r
P64	4e	4e	4e
P65	—	—	5e
P66	4c	4c	4c
P67	—	—	5c
P68	4g	4g	4g
P69	—	—	5g
P70	4m	4m	4m
P71	—	—	5m
P72	4f	4f	4f
P73	—	—	5f
P74	4b	4b	4b
P75	—	—	5b
P76	4k	4k	4k
P77	—	—	5k
P78	4j	4j	4j
P79	—	—	5j
P80	4h	4h	4h
P81	—	—	5h
P82	4a	4a	4a
P83	—	—	5a
P84	S14	S14	S14

DTC114YUA
2SA1576A
2SC4617



2SB1188

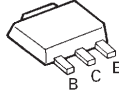

2SB1184

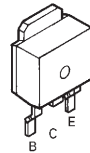

2SB1443

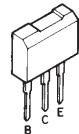

2SC4081

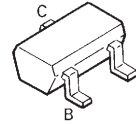

KTA1046-P

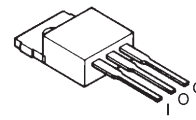

DAP202U
DA204U



M5237ML-CF0J

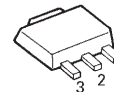

CAUTION : For continued safety, replace safety critical components only with manufacturer's recommended parts (refer to parts list).

⚠ Indicates safety critical components. To reduce the risk of electric shock, leakage-current or resistance measurements shall be carried out (exposed parts are acceptably insulated from the supply circuit) before the appliance is returned to the customer.

- DC voltages are as measured with a high impedance voltmeter. Values may vary slightly due to variations between individual instruments or/and units.

1
2
3
4
5
6
7

1

2

3

4

5

6

7

CD PLAYER UNIT (X32-6130-00)

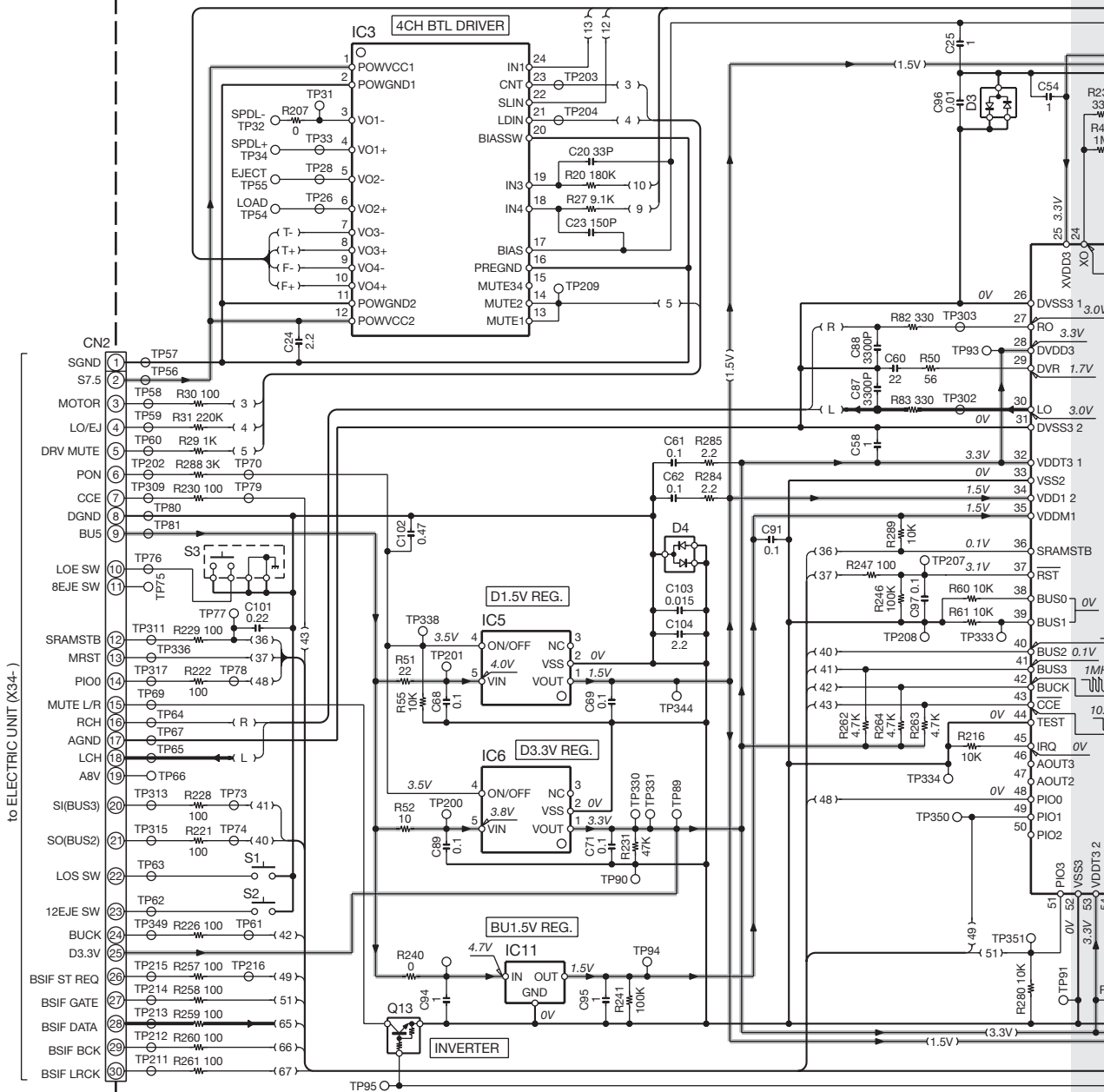

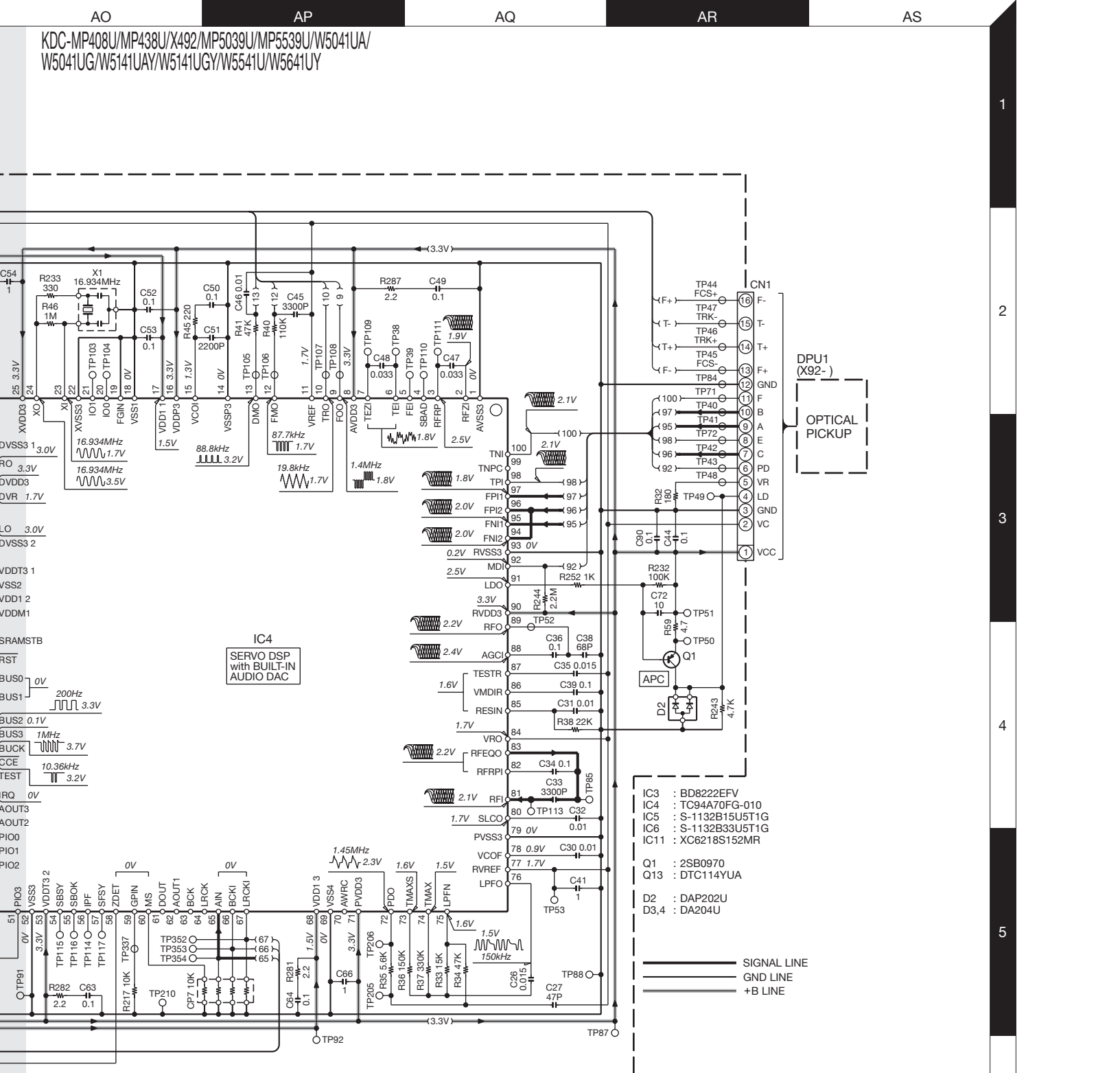

CAUTION : For continued safety, replace safety critical components only with manufacturer's recommended parts (refer to parts list).
 △ Indicates safety critical components. To reduce the risk of electric shock, leakage-current or resistance measurements shall be carried out (exposed parts are acceptably insulated from the supply circuit) before the appliance is returned to the customer.

- DC voltages are as measured with a high impedance voltmeter. Values may vary slightly due to variations between individual instruments or/and units.

- IC3 : BD8222EFV
 IC4 : TC94A70FG-010
 IC5 : S-1132B15U5T1G
 IC6 : S-1132B33U5T1G
 IC11 : XC6218S152MR
 Q1 : 2SB0970
 Q13 : DTC114YUA
 D2 : DAP202U
 D3,4 : DA204U

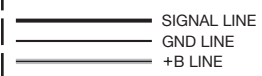

EXPLODED VIEW (CD MECHANISM)

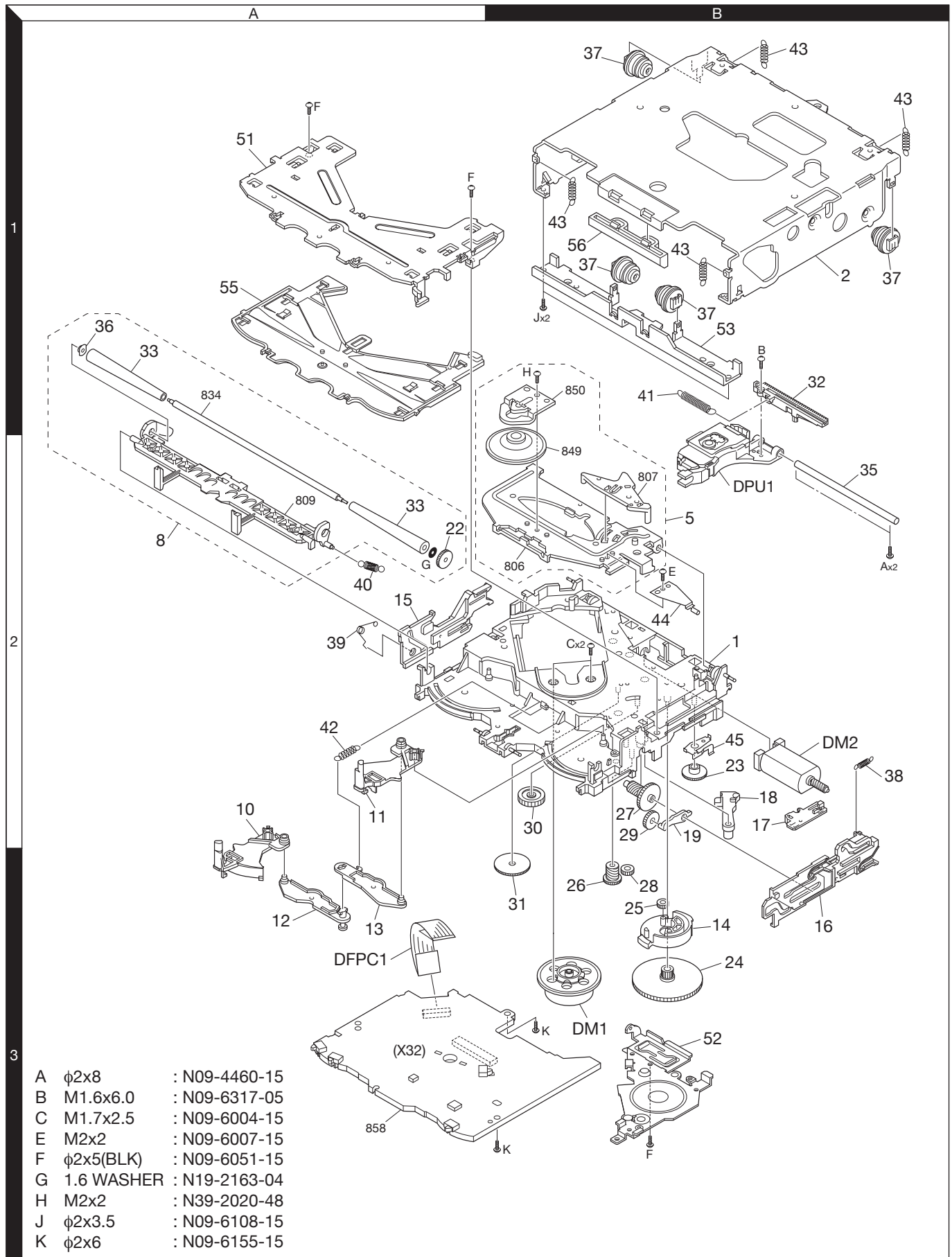

A	φ2x8	: N09-4460-15
B	M1.6x6.0	: N09-6317-05
C	M1.7x2.5	: N09-6004-15
E	M2x2	: N09-6007-15
F	φ2x5(BLK)	: N09-6051-15
G	1.6 WASHER	: N19-2163-04
H	M2x2	: N39-2020-48
J	φ2x3.5	: N09-6108-15
K	φ2x6	: N09-6155-15

Parts with the exploded numbers larger than 700 are not supplied.

EXPLODED VIEW (UNIT)

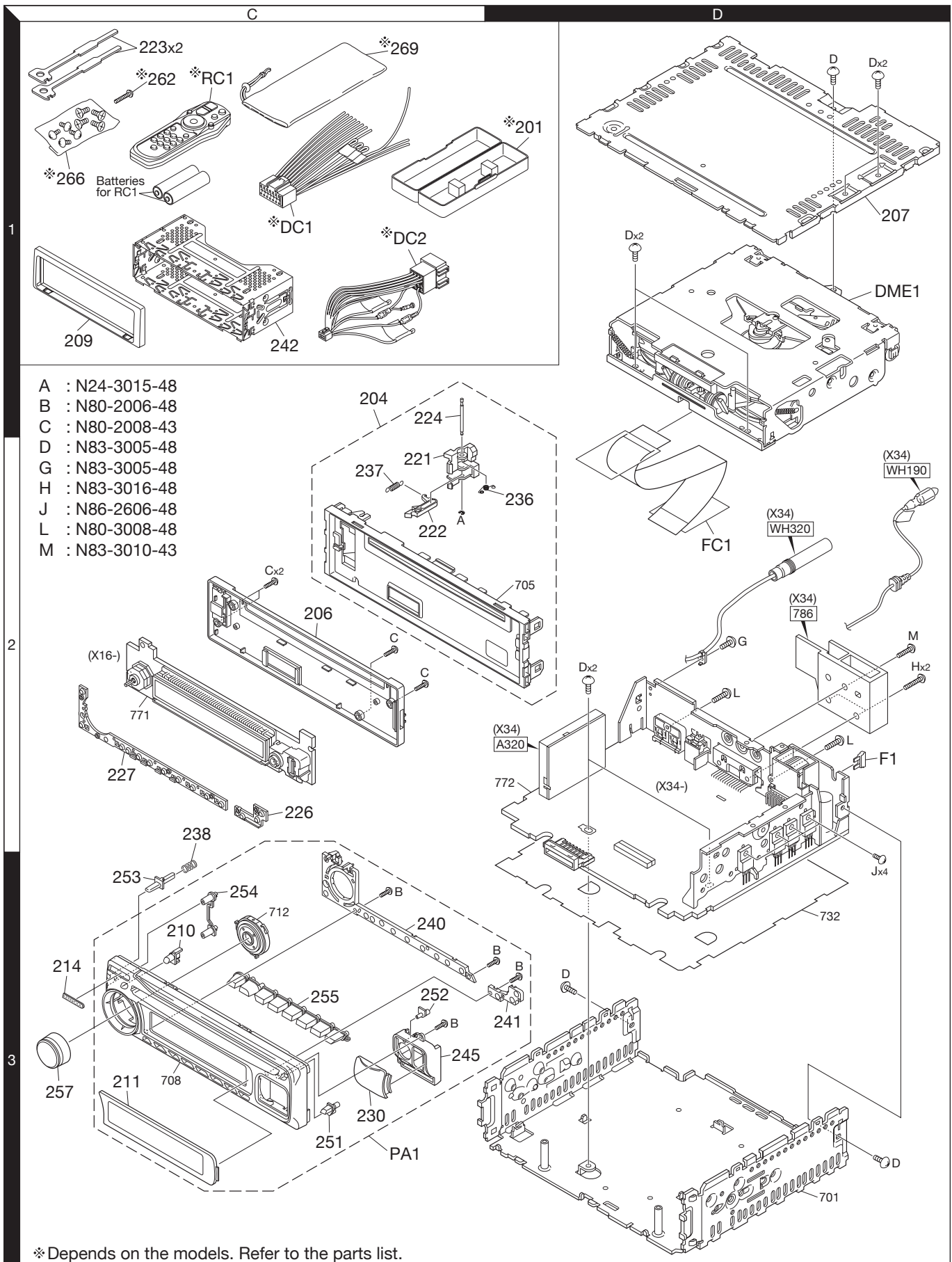

PARTS LIST

* New parts

Parts without **Parts No.** are not supplied.

Les articles non mentionnés dans le **Parts No.** ne sont pas fournis.

Teile ohne **Parts No.** werden nicht geliefert.

Ref. No.	A d d	N e w	Parts No.	Description	Desti- nation	Ref. No.	A d d	N e w	Parts No.	Description	Desti- nation
KDC-MP408U/438U/MP5039U/MP5539U/X492/ W5041xx/W5141xxx/W5541U/W5641UY						△ F1	2D		F52-0023-05	FUSE (MINI BLADE TYPE) (10A)	
201	1D	*	A02-2755-13	PLASTIC CABINET ASSY	M1M2	236	2D		G01-2987-04	TORSION COIL SPRING	
204	1C	*	A22-3158-03	SUB PANEL ASSY		237	2C	*	G01-4662-04	EXTENSION SPRING	
206	2C	*	A46-1864-01	REAR COVER		238	2C		G01-3244-04	COMPRESSION SPRING (REL)	
207	1D	*	A52-0897-02	TOP PLATE		-		*	H54-4263-03	ITEM CARTON CASE	K1
PA1	3C	*	A64-4398-02	PANEL ASSY	K1	-		*	H54-4264-03	ITEM CARTON CASE	K2
PA1	3C	*	A64-4399-02	PANEL ASSY	K2	-		*	H54-4265-03	ITEM CARTON CASE	K3
PA1	3C	*	A64-4400-02	PANEL ASSY	K3	-		*	H54-4266-03	ITEM CARTON CASE	M1
PA1	3C	*	A64-4401-02	PANEL ASSY	M1	-		*	H54-4267-03	ITEM CARTON CASE	M2
PA1	3C	*	A64-4402-02	PANEL ASSY	M2	-		*	H54-4268-03	ITEM CARTON CASE	E1
PA1	3C	*	A64-4403-02	PANEL ASSY	E1	-		*	H54-4269-03	ITEM CARTON CASE	E2
PA1	3C	*	A64-4404-02	PANEL ASSY	E2E3	-		*	H54-4270-03	ITEM CARTON CASE	E3
PA1	3C	*	A64-4405-02	PANEL ASSY	E4	-		*	H54-4271-03	ITEM CARTON CASE	E4
PA1	3C	*	A64-4406-02	PANEL ASSY	E5E6	-		*	H54-4272-03	ITEM CARTON CASE	E5
RC1	1C		A70-2085-05	REMOTE CONTROLLER ASSY (RC-547)	K1K2K3	-		*	H54-4273-03	ITEM CARTON CASE	E6
RC1	1C		A70-2085-05	REMOTE CONTROLLER ASSY (RC-547)	M1M2E4	240	3C	*	J19-7192-02	HOLDER (PRESET)	
RC1	1C		A70-2085-05	REMOTE CONTROLLER ASSY (RC-547)	E5E6	241	3D	*	J19-7193-03	HOLDER (EJECT/RESET)	
-		*	B64-3955-00	INST. MANUAL (ENG.FRE.SPA.)	K1K2K3	242	1C		J21-9716-03	MOUNTING HARDWARE ASSY	
-		*	B64-3956-00	INST. MANUAL (ENG.S-CHI.)	M1M2	245	3C	*	J90-1162-02	GUIDE	
-		*	B64-3957-00	INST. MANUAL (ARABIC)	M1M2	251	3C	*	K24-4798-04	PUSH KNOB (EJECT)	
-		*	B64-3958-00	INST. MANUAL (ENGLISH)	E1E2E3	252	3C	*	K24-4799-04	PUSH KNOB (RESET)	
-		*	B64-3958-00	INST. MANUAL (ENGLISH)	E4E5E6	253	3C	*	K24-4800-04	PUSH KNOB (RELEASE)	
-		*	B64-3959-00	INST. MANUAL (FRE.GER.DUT.)	E1E2E3	254	3C	*	K25-1917-03	PUSH KNOB (AME/DSP)	
-		*	B64-3960-00	INST. MANUAL (ITA.SPA.POR.)	E1E2E3	255	3C	*	K25-1918-02	PUSH KNOB (PRESET)	
-		*	B64-3961-00	INST. MANUAL (RUSSIAN)	E4E5E6	257	3C	*	K28-0280-04	KNOB ASSY (VOL)	
209	1C	*	B07-3244-01	ESCUTCHEON	K2K3E1	262	1C		N84-4016-48	PAN HEAD TAPTITE SCREW	K1K2K3
209	1C	*	B07-3244-01	ESCUTCHEON	E2E3E4	262	1C		N84-4016-48	PAN HEAD TAPTITE SCREW	M1M2
209	1C	*	B07-3245-01	ESCUTCHEON	E5E6	266	1C	*	N99-1757-15	SCREW SET	K1K2K3
210	3C	*	B10-5047-04	FRONT GLASS (REMOTE)	K1M1M2	266	1C	*	N99-1757-15	SCREW SET	M1M2
211	3C	*	B10-5061-01	FRONT GLASS	K1	A	2C		N24-3015-48	E TYPE RETAINING RING	
211	3C	*	B10-5062-01	FRONT GLASS	K2	B	3C		N80-2006-48	PAN HEAD TAPTITE SCREW	
211	3C	*	B10-5063-01	FRONT GLASS	K3	C	2C		N80-2008-43	PAN HEAD TAPTITE SCREW	
211	3C	*	B10-5064-01	FRONT GLASS	M1	D	1D		N83-3005-48	PAN HEAD TAPTITE SCREW	
211	3C	*	B10-5065-01	FRONT GLASS	M2	269	1C		W01-1664-05	CARRYING CASE	K1
211	3C	*	B10-5066-01	FRONT GLASS	E1	269	1C	*	W01-1710-05	CARRYING CASE	K2K3E1
211	3C	*	B10-5067-01	FRONT GLASS	E2E3	269	1C	*	W01-1710-05	CARRYING CASE	E2E3E4
211	3C	*	B10-5068-01	FRONT GLASS	E4	269	1C	*	W01-1710-05	CARRYING CASE	E5E6
211	3C	*	B10-5069-01	FRONT GLASS	E5E6	DME1	1D	*	X92-6130-00	MECHANISM ASSY (DXM-6E20W)	
214	3C		B43-1518-04	BADGE		SWITCH UNIT (X16-622x-xx)					
221	2C		D10-4446-03	LEVER		D1-12			B30-1779-05	LED (1608,SR)	K2K3E2
222	2C		D10-4447-03	LEVER		D1-12			B30-1779-05	LED (1608,SR)	E5
223	1C	*	D10-7012-04	LEVER		D1-12			B30-1780-05	LED (1608,PG)	E3E6
224	1C		D21-2329-04	SHAFT		D1-12			B30-1781-05	LED (1608,BLUE)	K1M1M2
226	2C	*	E29-2117-03	CONDUCTIVE RUBBER (EJECT)		D1-12			B30-1781-05	LED (1608,BLUE)	E1E4
227	2C	*	E29-2118-02	CONDUCTIVE RUBBER (PRESET)		D16			B30-1779-05	LED (1608,SR)	
△ DC1	1C		E30-6428-05	DC CORD	K1K2K3	D21-23			B30-1779-05	LED (1608,SR)	E2E5
△ DC1	1C		E30-6428-05	DC CORD	M1M2	D21-23			B30-1781-05	LED (1608,BLUE)	K1K2K3
△ DC2	1C		E30-6671-05	DC CORD	E1E2E3	D21-23			B30-1781-05	LED (1608,BLUE)	M1M2E1
△ DC2	1C		E30-6671-05	DC CORD	E4E5E6	D21-23			B30-1781-05	LED (1608,BLUE)	E4
FC1	2D	*	E39-0981-05	FLAT CABLE		D21-27			B30-1780-05	LED (1608,PG)	E3E6
230	3C	*	F07-1194-02	COVER		D27			B30-1779-05	LED (1608,SR)	E2E5

K1 : KDC-X492 **K2** : KDC-MP438U **K3** : KDC-MP408U **M1** : KDC-MP5539U
M2 : KDC-MP5039U **E1** : KDC-W5541U **E2** : KDC-W5041UA **E3** : KDC-W5041UG
E4 : KDC-W5641UY **E5** : KDC-W5141UAY **E6** : KDC-W5141UGY

△ Indicates safety critical components.

PARTS LIST

SWITCH UNIT (X16-622x-xx)

Ref. No.	A d d	N e w	Parts No.	Description	Desti- nation
D27			B30-1781-05	LED (1608,BLUE)	K1K2K3
D27			B30-1781-05	LED (1608,BLUE)	M1M2E1
D27			B30-1781-05	LED (1608,BLUE)	E4
D115,116			B30-1779-05	LED (1608,SR)	E2E5
D115,116			B30-1781-05	LED (1608,BLUE)	K1K2K3
D115,116			B30-1781-05	LED (1608,BLUE)	M1M2E1
D115,116			B30-1781-05	LED (1608,BLUE)	E4
C8			CK73GB1A105K	CHIP C 1.0UF K	
C10			CK73GB1C104K	CHIP C 0.10UF K	
C28			CC73GCH1H102J	CHIP C 1000PF J	
C29			CC73GCH1H471J	CHIP C 470PF J	
C31			CK73GB1C104K	CHIP C 0.10UF K	
C32			CK73GB1H103K	CHIP C 0.010UF K	
J1		*	E59-0854-05	RECTANGULAR PLUG	
J3		*	E11-0654-05	3.5D PHONE JACK	
J4			E58-1062-05	RECTANGULAR RECEPTACLE	
CP10,11			RK74HB1J101J	CHIP-COM 100 J 1/16W	
CP14			RK74HB1J473J	CHIP-COM 47K J 1/16W	
R2			RK73GB2A221J	CHIP R 220 J 1/10W	
R5			RK73GB2A221J	CHIP R 220 J 1/10W	
R7			RK73GB2A221J	CHIP R 220 J 1/10W	
R10			RK73GB2A104J	CHIP R 100K J 1/10W	
R11			RK73GB2A4R7J	CHIP R 4.7 J 1/10W	
R13			RK73GB2A101J	CHIP R 100 J 1/10W	
R15			RK73GB2A101J	CHIP R 100 J 1/10W	
R20			RK73GB2A101J	CHIP R 100 J 1/10W	
R21			RK73GB2A104J	CHIP R 100K J 1/10W	
R51-54			RK73FB2B621J	CHIP R 620 J 1/8W	K2K3
R51-55			RK73FB2B271J	CHIP R 270 J 1/8W	K1M1M2
R51-55			RK73FB2B271J	CHIP R 270 J 1/8W	E1E4
R51-55			RK73FB2B561J	CHIP R 560 J 1/8W	E3E6
R51-55			RK73FB2B621J	CHIP R 620 J 1/8W	E2E5
R55			RK73FB2B271J	CHIP R 270 J 1/8W	K2K3
R56			RK73EB2E821J	CHIP R 820 J 1/4W	E3E6
R60			RK73EB2E271J	CHIP R 270 J 1/4W	K1K2K3
R60			RK73EB2E271J	CHIP R 270 J 1/4W	M1M2E1
R60			RK73EB2E271J	CHIP R 270 J 1/4W	E4
R60			RK73EB2E621J	CHIP R 620 J 1/4W	E2E5
R60			RK73EB2E821J	CHIP R 820 J 1/4W	E3E6
R74,75			RK73PB2H300J	CHIP R 30 J 1/2W	
R80			RK73GB2A222J	CHIP R 2.2K J 1/10W	
R81			RK73GB2A223J	CHIP R 22K J 1/10W	
R112			RK73GB2A104J	CHIP R 100K J 1/10W	
R113			RK73EB2E102J	CHIP R 1.0K J 1/4W	
R117,118			RK73GB2A103J	CHIP R 10K J 1/10W	
S1		*	S70-0947-05	TACT SWITCH	
D104			UDZW5.6(B)	ZENER DIODE	
ED1		*	3-BT-259INK	FLUORESCENT INDICATOR TUBE	
IC2			PIC95603	ANALOGUE IC	
Q5			2SC4617	TRANSISTOR	
Q20			RT1N441U	TRANSISTOR	
Q21			RT1P141U	TRANSISTOR	

Ref. No.	A d d	N e w	Parts No.	Description	Desti- nation
Q22-24			DTA123JUA	DIGITAL TRANSISTOR	
CD PLAYER UNIT (X32-6130-00) IN CD MECHA					
C20			CC73GCH1H330J	CHIP C 33PF J	
C23			CC73GCH1H151J	CHIP C 150PF J	
C24			CK73FB1A225K	CHIP C 2.2UF K	
C25			CK73GB1A105K	CHIP C 1.0UF K	
C26			CK73GB1H153K	CHIP C 0.015UF K	
C27			CC73GCH1H470J	CHIP C 47PF J	
C30-32			CK73GB1H103K	CHIP C 0.010UF K	
C33			CK73GB1H332K	CHIP C 3300PF K	
C34			CK73GB1H104K	CHIP C 0.10UF K	
C35			CK73GB1H153K	CHIP C 0.015UF K	
C36			CK73GB1H104K	CHIP C 0.10UF K	
C38			CC73GCH1H680J	CHIP C 68PF J	
C39			CK73GB1H104K	CHIP C 0.10UF K	
C41			CK73GB1A105K	CHIP C 1.0UF K	
C44			CK73GB1H104K	CHIP C 0.10UF K	
C45			CK73GB1H332K	CHIP C 3300PF K	
C46			CK73GB1H103K	CHIP C 0.010UF K	
C47,48			CK73GB1H333K	CHIP C 0.033UF K	
C49,50			CK73GB1H104K	CHIP C 0.10UF K	
C51			CK73GB1H222K	CHIP C 2200PF K	
C52,53			CK73GB1H104K	CHIP C 0.10UF K	
C54			CK73GB1A105K	CHIP C 1.0UF K	
C58			CK73GB1A105K	CHIP C 1.0UF K	
C60			CK73EB0J226K	CHIP C 22UF K	
C61-64			CK73GB1H104K	CHIP C 0.10UF K	
C66			CK73FB1C105K	CHIP C 1.0UF K	
C68,69			CK73GB1H104K	CHIP C 0.10UF K	
C71			CK73GB1H104K	CHIP C 0.10UF K	
C72			CK73FB0J106K	CHIP C 10UF K	
C87,88			CK73GB1H332K	CHIP C 3300PF K	
C89-91			CK73GB1H104K	CHIP C 0.10UF K	
C94,95			CK73GB1A105K	CHIP C 1.0UF K	
C96			CK73GB1H103K	CHIP C 0.010UF K	
C97			CK73GB1H104K	CHIP C 0.10UF K	
C101			CK73GB1C224K	CHIP C 0.22UF K	
C102			CK73GB1A474K	CHIP C 0.47UF K	
C103			CK73GB1H153K	CHIP C 0.015UF K	
C104			CK73FB1A225K	CHIP C 2.2UF K	
CN1			E41-2612-05	FLAT CABLE CONNECTOR	
CN2			E41-2630-05	FLAT CABLE CONNECTOR	
X1			L78-1221-05	RESONATOR (16.93MHZ)	
CP7			RK74GB1J103J	CHIP-COM 10K J 1/16W	
R20			RK73GB2A184J	CHIP R 180K J 1/10W	
R27			RK73GB2A912J	CHIP R 9.1K J 1/10W	
R29			RK73GB2A102J	CHIP R 1.0K J 1/10W	
R30			RK73GB2A101J	CHIP R 100 J 1/10W	
R31			RK73GB2A224J	CHIP R 220K J 1/10W	
R32			RK73GB2A181J	CHIP R 180 J 1/10W	
R33			RK73GB2A153J	CHIP R 15K J 1/10W	
R34			RK73GB2A473J	CHIP R 47K J 1/10W	
R35			RK73GB2A562J	CHIP R 5.6K J 1/10W	

K1 : KDC-X492 K2 : KDC-MP438U K3 : KDC-MP408U M1 : KDC-MP5539U
M2 : KDC-MP5039U E1 : KDC-W5541U E2 : KDC-W5041UA E3 : KDC-W5041UG
E4 : KDC-W5641UY E5 : KDC-W5141UAY E6 : KDC-W5141UGY

△Indicates safety critical components.

PARTS LIST

CD PLAYER UNIT (X32-6130-00) IN CD MECHA

Ref. No.	Add	New	Parts No.	Description	Destination	Ref. No.	Add	New	Parts No.	Description	Destination
R36			RK73GB2A154J	CHIP R 150K J 1/10W		C10			CD04AT1A221M	ELECTRO 220UF 10WV	
R37			RK73GB2A334J	CHIP R 330K J 1/10W		C11			CK73GB1A105K	CHIP C 1.0UF K	
R38			RK73GB2A223J	CHIP R 22K J 1/10W		C12			CK73GB1C104K	CHIP C 0.10UF K	
R40			RK73GB2A114J	CHIP R 110K J 1/10W		C20			C90-6851-05	ELECTRO 220UF 25WV	
R41			RK73GB2A473J	CHIP R 47K J 1/10W		C22			CD04AS1V100M	ELECTRO 10UF 35WV	
R45			RK73GB2A221J	CHIP R 220 J 1/10W		C23			CD04AS0J101M	ELECTRO 100UF 6.3WV	
R46			RK73GB2A105J	CHIP R 1.0M J 1/10W		C25,26			CK73GB1A105K	CHIP C 1.0UF K	
R50			RK73GB2A560J	CHIP R 56 J 1/10W		C27			CD04AS0J470M	ELECTRO 47UF 6.3WV	
R51			RK73EB2E220J	CHIP R 22 J 1/4W		C30			CK73GB1A447K	CHIP C 0.47UF K	
R52			RK73EB2E100J	CHIP R 10 J 1/4W		C31			CD04AS1C101M	ELECTRO 100UF 16WV	
R55			RK73GB2A103J	CHIP R 10K J 1/10W		C40			CK73GB1C104K	CHIP C 0.10UF K	
R59			RK73GB2A4R7J	CHIP R 4.7 J 1/10W		C42			CD04AS1C220M	ELECTRO 22UF 16WV	
R60,61			RK73GB2A103J	CHIP R 10K J 1/10W		C51			CD04AS1V100M	ELECTRO 10UF 35WV	
R82,83			RK73GB2A331J	CHIP R 330 J 1/10W		C60			CD04BK1E101M	ELECTRO 100UF 25WV	
R207			RK73EB2E000J	CHIP R 0.0 J 1/4W		C61			CK73GB1C104K	CHIP C 0.10UF K	
R216,217			RK73GB2A103J	CHIP R 10K J 1/10W		C62			CD04BK1A221M	ELECTRO 220UF 10WV	
R221,222			RK73GB2A101J	CHIP R 100 J 1/10W		C64			CK73GB1C104K	CHIP C 0.10UF K	
R226			RK73GB2A101J	CHIP R 100 J 1/10W		C65			CK73GB1H222K	CHIP C 2200PF K	
R228-230			RK73GB2A101J	CHIP R 100 J 1/10W		C67			CD04BK1A221M	ELECTRO 220UF 10WV	
R231			RK73GB2A473J	CHIP R 47K J 1/10W		C68,69			CK73GB1H102K	CHIP C 1000PF K	
R232			RK73GB2A104J	CHIP R 100K J 1/10W		C100			CD04AS1E470M	ELECTRO 47UF 25WV	K1
R233			RK73GB2A331J	CHIP R 330 J 1/10W		C101			CD04AS1C220M	ELECTRO 22UF 16WV	K1
R240			RK73EB2E000J	CHIP R 0.0 J 1/4W		C102			CD04AS1C470M	ELECTRO 47UF 16WV	K1
R241			RK73GB2A104J	CHIP R 100K J 1/10W		C103			CK73GB1H102K	CHIP C 1000PF K	K1
R243			RK73GB2A472J	CHIP R 4.7K J 1/10W		C122			CK73GB1H103K	CHIP C 0.010UF K	
R244			RK73GB2A225J	CHIP R 2.2M J 1/10W		C140			CD04AS1H3R3M	ELECTRO 3.3UF 50WV	
R246			RK73GB2A104J	CHIP R 100K J 1/10W		C141			CK73GB1A105K	CHIP C 1.0UF K	
R247			RK73GB2A101J	CHIP R 100 J 1/10W		C142			CK73GB1H104K	CHIP C 0.10UF K	
R252			RK73GB2A102J	CHIP R 1.0K J 1/10W		C160			CK73GB1H103K	CHIP C 0.010UF K	
R257-261			RK73GB2A101J	CHIP R 100 J 1/10W		C170			CK73GB1A105K	CHIP C 1.0UF K	
R262-264			RK73GB2A472J	CHIP R 4.7K J 1/10W		C171			CK73GB1H223K	CHIP C 0.022UF K	
R280			RK73GB2A103J	CHIP R 10K J 1/10W		C230			CK73GB1C104K	CHIP C 0.10UF K	
R281,282			RK73GB2A2R2J	CHIP R 2.2 J 1/10W		C232			CK73GB1C104K	CHIP C 0.10UF K	
R284,285			RK73GB2A2R2J	CHIP R 2.2 J 1/10W		C233			CD04BK1A221M	ELECTRO 220UF 10WV	
R287			RK73GB2A2R2J	CHIP R 2.2 J 1/10W		C300,301			CC73GCH1H220J	CHIP C 22PF J	E1E2E3
R288			RK73GB2A302J	CHIP R 3.0K J 1/10W		C300,301			CC73GCH1H220J	CHIP C 22PF J	E4E5E6
R289			RK73GB2A103J	CHIP R 10K J 1/10W		C303			CK73GB1H103K	CHIP C 0.010UF K	E1E2E3
S1,2			S68-0863-05	PUSH SWITCH		C303			CK73GB1H103K	CHIP C 0.010UF K	E4E5E6
S3			S68-0862-05	PUSH SWITCH		C305			CK73GB1C104K	CHIP C 0.10UF K	E1E2E3
D2			DAP202U	DIODE		C305			CK73GB1C104K	CHIP C 0.10UF K	E4E5E6
D3,4			DA204U	DIODE		C306			CK73FB1A225K	CHIP C 2.2UF K	E1E2E3
IC3		*	BD8222EFV	ANALOGUE IC		C306			CK73FB1A225K	CHIP C 2.2UF K	E4E5E6
IC4		*	TC94A70FG-010	MOS-IC		C307			CC73GCH1H331J	CHIP C 330PF J	E1E2E3
IC5			S-1132B15U5T1G	ANALOGUE IC		C307			CC73GCH1H331J	CHIP C 330PF J	E4E5E6
IC6			S-1132B33U5T1G	ANALOGUE IC		C318			CD04AS1C470M	ELECTRO 47UF 16WV	K1
IC11		*	XC6218S152MR	MOS-IC		C320-323			CK73GB1H103K	CHIP C 0.010UF K	
Q1			2SB0970	TRANSISTOR		C400,401			CD04AS1V100M	ELECTRO 10UF 35WV	
Q13			DTC114YUA	DIGITAL TRANSISTOR		C402,403			CK73GB1H102K	CHIP C 1000PF K	
ELECTRIC UNIT (X34-577x-xx)						C410,411			CD04AS1V100M	ELECTRO 10UF 35WV	K1K2M1
C1			CD04AZ1C332M2	ELECTRO 3300UF 16WV	K2K3M1	C410,411			CD04AS1V100M	ELECTRO 10UF 35WV	M2
C1			CD04AZ1C332M2	ELECTRO 3300UF 16WV	M2E1E2	C412,413			CK73GB1H102K	CHIP C 1000PF K	K1K2M1
C1			CD04AZ1C332M2	ELECTRO 3300UF 16WV	E3E4E5	C412,413			CK73GB1H102K	CHIP C 1000PF K	M2
C1			CD04AZ1C332M2	ELECTRO 3300UF 16WV	E6	C420,421			CD04AS1V100M	ELECTRO 10UF 35WV	K1K2
C1			C90-6746-05	ELECTRO 3300UF 16WV	K1	C422,423			CK73GB1H102K	CHIP C 1000PF K	K1K2
						C440			CK73FB1E474K	CHIP C 0.47UF K	

K1 : KDC-X492 **K2** : KDC-MP438U **K3** : KDC-MP408U **M1** : KDC-MP5539U
M2 : KDC-MP5039U **E1** : KDC-W5541U **E2** : KDC-W5041UA **E3** : KDC-W5041UG
E4 : KDC-W5641UY **E5** : KDC-W5141UAY **E6** : KDC-W5141UGY

△ Indicates safety critical components.

PARTS LIST

ELECTRIC UNIT (X34-577x-xx)

Ref. No.	Ad	New	Parts No.	Description	Destination	Ref. No.	Ad	New	Parts No.	Description	Destination
C441			CD04AT0J470M	ELECTRO 47UF 6.3WV		△ J1			E58-0991-05	RECTANGULAR RECEPTACLE	
C442			CK73FB1E474K	CHIP C 0.47UF K		J400		*	E63-0953-05	PIN JACK	K1K2
C443			CK73GB1H103K	CHIP C 0.010UF K		J400		*	E63-0954-05	PIN JACK	M1M2
C445			CK73FB1E474K	CHIP C 0.47UF K		J400		*	E63-0955-05	PIN JACK	K3E1E2
C446			CE32BJ0J470M	CHIP EL 47UF 6.3WV		J400		*	E63-0955-05	PIN JACK	E3E4E5
C447			CK73FB1E474K	CHIP C 0.47UF K		J400		*	E63-0955-05	PIN JACK	E6
C448			CK73GB1H103K	CHIP C 0.010UF K		J440			E56-0855-05	CYLINDRICAL RECEPTACLE	
C478,479			CK73GB1A474K	CHIP C 0.47UF K		W660		*	E58-1095-05	RECTANGULAR RECEPTACLE	
C480,481			CD04AS1H2R2M	ELECTRO 2.2UF 50WV		W320	2D	*	E30-6803-05	CORD WITH PLUG	
C482,483			CK73GB1A105K	CHIP C 1.0UF K		WH190	2D	*	E30-6706-05	WIRING HARNESS (REMOTE)	
C486-488			CK73GB1A105K	CHIP C 1.0UF K		△ L1			L33-2365-05	CHOKE COIL ASSY	
C489-491			CD04AS1H2R2M	ELECTRO 2.2UF 50WV		L60		*	L33-2456-05	SMALL FIXED INDUCTOR	
C492,493			CK73GB1A105K	CHIP C 1.0UF K		L600			L41-4795-33	SMALL FIXED INDUCTOR (4.7UH)	
C494			CK73GB1H103K	CHIP C 0.010UF K		L704			L41-4795-33	SMALL FIXED INDUCTOR (4.7UH)	
C495			CD04AS1V100M	ELECTRO 10UF 35WV	K2K3M1	X300			L77-2002-05	CRYSTAL RESONATOR	E1E2E3
C495			CD04AS1V100M	ELECTRO 10UF 35WV	M2E1E2	X300			L77-2002-05	CRYSTAL RESONATOR	E4E5E6
C495			CD04AS1V100M	ELECTRO 10UF 35WV	E3E4E5	X600			L77-2921-05	CRYSTAL RESONATOR (32.768KHZ)	
C495			CD04AS1V100M	ELECTRO 10UF 35WV	E6	X601			L78-0872-05	RESONATOR (12MHZ)	
C496			CD04AS1C470M	ELECTRO 47UF 16WV		X700			L77-2921-05	CRYSTAL RESONATOR (32.768KHZ)	
C500-503			CK73GB1A224K	CHIP C 0.22UF K		X701		*	L77-2964-05	CRYSTAL RESONATOR (9.00MHZ)	
C504			C90-6711-05	ELECTRO 1UF 50WV		X750			L77-2921-05	CRYSTAL RESONATOR (32.768KHZ)	K1K2M1
C506,507			CK73GB1A105K	CHIP C 1.0UF K		X750			L77-2921-05	CRYSTAL RESONATOR (32.768KHZ)	E1E4
C508			CD04AS1A330M	ELECTRO 33UF 10WV	K3M1M2	G	2D		N83-3005-48	PAN HEAD TAPTITE SCREW	
C508			CD04AS1A330M	ELECTRO 33UF 10WV	E1E2E3	H	2D		N83-3016-48	PAN HEAD TAPTITE SCREW	
C508			CD04AS1A330M	ELECTRO 33UF 10WV	E4E5E6	J	3D		N86-2606-48	BINDING HEAD TAPTITE SCREW	
C508			CD04AS1V100M	ELECTRO 10UF 35WV	K1K2	L	2D		N80-3008-48	PAN HEAD TAPTITE SCREW	
C520-527			CK73GB1H392K	CHIP C 3900PF K	E1E2E3	M	2D	*	N83-3010-43	PAN HEAD TAPTITE SCREW	
C520-527			CK73GB1H392K	CHIP C 3900PF K	E4E5E6	CP440,441			RK74GA1J101J	CHIP-COM 100 J 1/16W	
C600			CC73GCH1H220J	CHIP C 22PF J		CP603-605			RK74GB1J101J	CHIP-COM 100 J 1/16W	
C601			CC73GCH1H180J	CHIP C 18PF J		CP606			RK74GA1J101J	CHIP-COM 100 J 1/16W	
C602			CK73GB1C104K	CHIP C 0.10UF K		CP607			RK74GA1J472J	CHIP-COM 4.7K J 1/16W	
C603,604			CK73GB1H103K	CHIP C 0.010UF K		CP608			RK74GA1J101J	CHIP-COM 100 J 1/16W	
C606,607			CK73GB1H103K	CHIP C 0.010UF K		R10			RK73GH2A432D	CHIP R 4.3K D 1/10W	
C611			CK73GB1H103K	CHIP C 0.010UF K		R11			RK73GH2A243D	CHIP R 24K D 1/10W	
C612			CK73GB1H102K	CHIP C 1000PF K		R12			RK73FB2B221J	CHIP R 220 J 1/8W	
C613,614			CK73GB1H103K	CHIP C 0.010UF K		R20			RK73FB2B123J	CHIP R 12K J 1/8W	
C616			CK73GB1A105K	CHIP C 1.0UF K		R21			RK73GB2A223J	CHIP R 22K J 1/10W	
C660			CK73GB1H102K	CHIP C 1000PF K		R22			RK73FB2B822J	CHIP R 8.2K J 1/8W	
C680,681			CK73GB1H103K	CHIP C 0.010UF K		R30			RK73FB2B152J	CHIP R 1.5K J 1/8W	
C701			CK73GB1H103K	CHIP C 0.010UF K		R31			RK73GB2A104J	CHIP R 100K J 1/10W	
C702			CC73GCH1H220J	CHIP C 22PF J		R40			RK73FB2B182J	CHIP R 1.8K J 1/8W	
C703			CC73GCH1H180J	CHIP C 18PF J		R41			RK73GB2A473J	CHIP R 47K J 1/10W	
C704-706			CK73GB1H103K	CHIP C 0.010UF K		R50			RK73FB2B681J	CHIP R 680 J 1/8W	
C708-710			CK73GB1H103K	CHIP C 0.010UF K		R60			RK73GB2A683J	CHIP R 68K J 1/10W	
C711,712			CC73GCH1H150J	CHIP C 15PF J		R61			RK73GB2A104J	CHIP R 100K J 1/10W	
C713-715			CK73GB1H103K	CHIP C 0.010UF K		R62			RK73GH2A623D	CHIP R 62K D 1/10W	
C716,717			CK73FB0J106K	CHIP C 10UF K		R63			RK73GH2A153D	CHIP R 15K D 1/10W	
C718			CK73GB0J105K	CHIP C 1.0UF K		R64			RK73EB2E100J	CHIP R 10 J 1/4W	
C750,751			CC73GCH1H050C	CHIP C 5.0PF C	K1K2M1	R65,66			RK73PB2H300J	CHIP R 30 J 1/2W	
C750,751			CC73GCH1H050C	CHIP C 5.0PF C	E1E4	R100			RK73PB2H220J	CHIP R 22 J 1/2W	K1
C752			CK73GB1C104K	CHIP C 0.10UF K	K1K2M1	R101			RK73GB2A221J	CHIP R 220 J 1/10W	K1
C752			CK73GB1C104K	CHIP C 0.10UF K	E1E4	R103			RK73GB2A102J	CHIP R 1.0K J 1/10W	K1
C754,755			CK73GB1H102K	CHIP C 1000PF K		R104			RK73FB2B102J	CHIP R 1.0K J 1/8W	K1
CN680			E41-2358-05	FLAT CABLE CONNECTOR		R105			RK73GB2A102J	CHIP R 1.0K J 1/10W	K1

K1 : KDC-X492 K2 : KDC-MP438U K3 : KDC-MP408U M1 : KDC-MP5539U
M2 : KDC-MP5039U E1 : KDC-W5541U E2 : KDC-W5041UA E3 : KDC-W5041UG
E4 : KDC-W5641UY E5 : KDC-W5141UAY E6 : KDC-W5141UGY

△Indicates safety critical components.

PARTS LIST

ELECTRIC UNIT (X34-577x-xx)

Ref. No.	Add	New	Parts No.	Description	Destination	Ref. No.	Add	New	Parts No.	Description	Destination
R106			RK73GB2A513J	CHIP R 51K J 1/10W	K1	R412,413			RK73GB2A223J	CHIP R 22K J 1/10W	M2
R107			RK73EB2E2R2J	CHIP R 2.2 J 1/4W	K1	R414,415			RK73FB2B181J	CHIP R 180 J 1/8W	K1K2M1
R108			RK73GB2A332J	CHIP R 3.3K J 1/10W	K1	R414,415			RK73FB2B181J	CHIP R 180 J 1/8W	M2
R109			RK73GB2A2R2J	CHIP R 2.2 J 1/10W	K1	R420,421			RK73GB2A331J	CHIP R 330 J 1/10W	K1K2
R110			RK73GB2A222J	CHIP R 2.2K J 1/10W	K1	R422,423			RK73GB2A223J	CHIP R 22K J 1/10W	K1K2
R111			RK73GB2A473J	CHIP R 47K J 1/10W	K1	R424,425			RK73FB2B181J	CHIP R 180 J 1/8W	K1K2
R112			RK73GB2A472J	CHIP R 4.7K J 1/10W	K1	R440			RK73EB2E432J	CHIP R 4.3K J 1/4W	
R113			RK73GB2A102J	CHIP R 1.0K J 1/10W	K1	R441,442			RK73EB2E101J	CHIP R 100 J 1/4W	
R114			RK73GB2A101J	CHIP R 100 J 1/10W	K1	R443			RK73EB2E432J	CHIP R 4.3K J 1/4W	
R120,121			RK73GB2A103J	CHIP R 10K J 1/10W		R444,445			RK73EB2E101J	CHIP R 100 J 1/4W	
R126			RK73GB2A183J	CHIP R 18K J 1/10W		R446			RK73EB2E100J	CHIP R 10 J 1/4W	
R127			RK73FB2B203J	CHIP R 20K J 1/8W		R447			RK73EB2E4R7J	CHIP R 4.7 J 1/4W	
R128			RK73GB2A104J	CHIP R 100K J 1/10W		R448			RK73EB2E100J	CHIP R 10 J 1/4W	
R129			RK73EB2E473J	CHIP R 47K J 1/4W		R449,450			RK73EB2E101J	CHIP R 100 J 1/4W	
R130			RK73EB2E102J	CHIP R 1.0K J 1/4W		R451			RK73GB2A102J	CHIP R 1.0K J 1/10W	
R131			RK73GB2A473J	CHIP R 47K J 1/10W		R454,455			RK73GB2A101J	CHIP R 100 J 1/10W	
R132			RK73FB2B683J	CHIP R 68K J 1/8W		R456,457			RK73GB2A104J	CHIP R 100K J 1/10W	
R133			RK73EB2E102J	CHIP R 1.0K J 1/4W		R458			RK73GB2A101J	CHIP R 100 J 1/10W	
R140			RK73FB2B472J	CHIP R 4.7K J 1/8W		R459,460			RK73GB2A104J	CHIP R 100K J 1/10W	
R141		*	RK73PB2H561J	CHIP R 560 J 1/2W		R461			RK73GB2A101J	CHIP R 100 J 1/10W	
R142			RK73GB2A223J	CHIP R 22K J 1/10W		R462			RK73GB2A104J	CHIP R 100K J 1/10W	
R143-145		*	RK73PB2H561J	CHIP R 560 J 1/2W		R464			RK73EB2E100J	CHIP R 10 J 1/4W	
R150			RK73GB2A223J	CHIP R 22K J 1/10W	K1K2K3	R465			RK73EB2E4R7J	CHIP R 4.7 J 1/4W	
R150			RK73GB2A223J	CHIP R 22K J 1/10W	M1M2	R466			RK73EB2E100J	CHIP R 10 J 1/4W	
R151,152			RK73PB2H221J	CHIP R 220 J 1/2W	K1K2K3	R467			RK73GB2A102J	CHIP R 1.0K J 1/10W	
R151,152			RK73PB2H221J	CHIP R 220 J 1/2W	M1M2	R480,481			RK73GB2A101J	CHIP R 100 J 1/10W	
R153			RK73FB2B472J	CHIP R 4.7K J 1/8W		R482,483			RK73GB2A103J	CHIP R 10K J 1/10W	
R160			RK73GB2A473J	CHIP R 47K J 1/10W		R484			RK73EB2E2R2J	CHIP R 2.2 J 1/4W	
R161			RK73GB2A104J	CHIP R 100K J 1/10W		R505			RK73GB2A333J	CHIP R 33K J 1/10W	K3M1M2
R162			RK73EB2E103J	CHIP R 10K J 1/4W		R505			RK73GB2A333J	CHIP R 33K J 1/10W	E1E2E3
R170			RK73GB2A104J	CHIP R 100K J 1/10W		R505			RK73GB2A333J	CHIP R 33K J 1/10W	E4E5E6
R171			RK73EB2E103J	CHIP R 10K J 1/4W		R505,506			RK73GB2A473J	CHIP R 47K J 1/10W	K1K2
R190			RK73EB2E102J	CHIP R 1.0K J 1/4W		R506			RK73GB2A223J	CHIP R 22K J 1/10W	K3M1M2
R230			RK73GB2A223J	CHIP R 22K J 1/10W		R506			RK73GB2A223J	CHIP R 22K J 1/10W	E1E2E3
R300-302			RK73GB2A222J	CHIP R 2.2K J 1/10W	E1E2E3	R506			RK73GB2A223J	CHIP R 22K J 1/10W	E4E5E6
R300-302			RK73GB2A222J	CHIP R 2.2K J 1/10W	E4E5E6	R508			RK73GB2A331J	CHIP R 330 J 1/10W	
R303			RK73GB2A102J	CHIP R 1.0K J 1/10W	E1E2E3	R509			RK73GB2A133J	CHIP R 13K J 1/10W	K3M1M2
R303			RK73GB2A102J	CHIP R 1.0K J 1/10W	E4E5E6	R509			RK73GB2A133J	CHIP R 13K J 1/10W	E1E2E3
R305			RK73GB2A512J	CHIP R 5.1K J 1/10W	E1E2E3	R509			RK73GB2A133J	CHIP R 13K J 1/10W	E4E5E6
R305			RK73GB2A512J	CHIP R 5.1K J 1/10W	E4E5E6	R509			RK73GB2A153J	CHIP R 15K J 1/10W	K1K2
R306			RK73GB2A223J	CHIP R 22K J 1/10W	E1E2E3	R511			RK73GB2A100J	CHIP R 10 J 1/10W	
R306			RK73GB2A223J	CHIP R 22K J 1/10W	E4E5E6	R513			RK73GB2A104J	CHIP R 100K J 1/10W	
R307			RK73GB2A222J	CHIP R 2.2K J 1/10W	E1E2E3	R514			RK73FB2B332J	CHIP R 3.3K J 1/8W	K3M1M2
R307			RK73GB2A222J	CHIP R 2.2K J 1/10W	E4E5E6	R514			RK73FB2B332J	CHIP R 3.3K J 1/8W	E1E2E3
R308,309			RK73GB2A104J	CHIP R 100K J 1/10W	E1E2E3	R514			RK73FB2B332J	CHIP R 3.3K J 1/8W	E4E5E6
R308,309			RK73GB2A104J	CHIP R 100K J 1/10W	E4E5E6	R515			RK73GB2A473J	CHIP R 47K J 1/10W	K3M1M2
R321			RK73GB2A223J	CHIP R 22K J 1/10W		R515			RK73GB2A473J	CHIP R 47K J 1/10W	E1E2E3
R322			RK73FB2B821J	CHIP R 820 J 1/8W		R515			RK73GB2A473J	CHIP R 47K J 1/10W	E4E5E6
R323,324			RK73GB2A471J	CHIP R 470 J 1/10W		R516			RK73GB2A102J	CHIP R 1.0K J 1/10W	
R400,401			RK73GB2A331J	CHIP R 330 J 1/10W		R600			RK73GB2A222J	CHIP R 2.2K J 1/10W	
R402,403			RK73GB2A223J	CHIP R 22K J 1/10W		R601			RK73GB2A225J	CHIP R 2.2M J 1/10W	
R404,405			RK73FB2B181J	CHIP R 180 J 1/8W		R602			RK73GB2A104J	CHIP R 100K J 1/10W	
R410,411			RK73GB2A331J	CHIP R 330 J 1/10W	K1K2M1	R603,604			RK73GB2A103J	CHIP R 10K J 1/10W	
R410,411			RK73GB2A331J	CHIP R 330 J 1/10W	M2	R605			RK73GB2A104J	CHIP R 100K J 1/10W	
R412,413			RK73GB2A223J	CHIP R 22K J 1/10W	K1K2M1	R606			RK73GB2A102J	CHIP R 1.0K J 1/10W	

K1 : KDC-X492 **K2** : KDC-MP438U **K3** : KDC-MP408U **M1** : KDC-MP5539U
M2 : KDC-MP5039U **E1** : KDC-W5541U **E2** : KDC-W5041UA **E3** : KDC-W5041UG
E4 : KDC-W5641UY **E5** : KDC-W5141UAY **E6** : KDC-W5141UGY

△ Indicates safety critical components.

PARTS LIST

ELECTRIC UNIT (X34-577x-xx)

Ref. No.	A d d	N e w	Parts No.	Description	Desti- nation	Ref. No.	A d d	N e w	Parts No.	Description	Desti- nation
R608,609			RK73GB2A473J	CHIP R 47K J 1/10W		R706			RK73GB2A223J	CHIP R 22K J 1/10W	
R610,611			RK73GB2A102J	CHIP R 1.0K J 1/10W		R707			RK73GB2A104J	CHIP R 100K J 1/10W	
R612,613			RK73GB2A472J	CHIP R 4.7K J 1/10W		R708			RK73GB2A101J	CHIP R 100 J 1/10W	
R614			RK73GB2A104J	CHIP R 100K J 1/10W		R709,710			RK73GB2A102J	CHIP R 1.0K J 1/10W	
R615			RK73GB2A473J	CHIP R 47K J 1/10W		R711			RK73GB2A223J	CHIP R 22K J 1/10W	
R617			RK73GB2A104J	CHIP R 100K J 1/10W		R713			RK73GB2A101J	CHIP R 100 J 1/10W	
R618			RK73GB2A471J	CHIP R 470 J 1/10W		R714			RK73GB2A223J	CHIP R 22K J 1/10W	
R619,620			RK73GB2A104J	CHIP R 100K J 1/10W		R715			RK73GB2A102J	CHIP R 1.0K J 1/10W	
R621			RK73GB2A471J	CHIP R 470 J 1/10W		R716-719			RK73GB2A101J	CHIP R 100 J 1/10W	
R622			RK73GB2A223J	CHIP R 22K J 1/10W		R720			RK73GB2A223J	CHIP R 22K J 1/10W	
R623,624			RK73GB2A101J	CHIP R 100 J 1/10W		R721			RK73GB2A101J	CHIP R 100 J 1/10W	K3M2E2
R628			RK73GB2A101J	CHIP R 100 J 1/10W		R721			RK73GB2A101J	CHIP R 100 J 1/10W	E3E5E6
R629			RK73GB2A222J	CHIP R 2.2K J 1/10W		R721,722			RK73GB2A101J	CHIP R 100 J 1/10W	K1K2M1
R633,634			RK73GB2A392J	CHIP R 3.9K J 1/10W		R721,722			RK73GB2A101J	CHIP R 100 J 1/10W	E1E4
R636			RK73GB2A223J	CHIP R 22K J 1/10W	K2M2E2	R723			RK73GB2A223J	CHIP R 22K J 1/10W	K1K2M1
R636			RK73GB2A223J	CHIP R 22K J 1/10W	E3E5E6	R723			RK73GB2A223J	CHIP R 22K J 1/10W	E1E4
R636			RK73GB2A473J	CHIP R 47K J 1/10W	K1M1E1	R724			RK73GB2A101J	CHIP R 100 J 1/10W	
R636			RK73GB2A473J	CHIP R 47K J 1/10W	E4	R725			RK73GB2A472J	CHIP R 4.7K J 1/10W	
R636-638			RK73GB2A473J	CHIP R 47K J 1/10W	K3	R726			RK73GB2A000J	CHIP R 0.0 J 1/10W	
R637			RK73GB2A473J	CHIP R 47K J 1/10W	M2	R727			RK73GB2A105J	CHIP R 1.0M J 1/10W	
R637-639			RK73GB2A473J	CHIP R 47K J 1/10W	E2E3	R728			RK73GB2A223J	CHIP R 22K J 1/10W	
R637,638			RK73GB2A473J	CHIP R 47K J 1/10W	K2E5E6	R729			RK73GB2A330J	CHIP R 33 J 1/10W	
R638			RK73GB2A223J	CHIP R 22K J 1/10W	M1M2	R730			RK73GB2A153J	CHIP R 15K J 1/10W	
R638			RK73GB2A473J	CHIP R 47K J 1/10W	K1E4	R731			RK73GB2A330J	CHIP R 33 J 1/10W	
R638,639			RK73GB2A473J	CHIP R 47K J 1/10W	E1	R732			RK73GB2A153J	CHIP R 15K J 1/10W	
R639			RK73GB2A223J	CHIP R 22K J 1/10W	E4E5E6	R733			RK73GB2A472J	CHIP R 4.7K J 1/10W	
R639			RK73GB2A473J	CHIP R 47K J 1/10W	M1M2	R734-737			RK73GB2A101J	CHIP R 100 J 1/10W	
R640			RK73GB2A222J	CHIP R 2.2K J 1/10W		R738			RK73GB2A223J	CHIP R 22K J 1/10W	
R642			RK73GB2A104J	CHIP R 100K J 1/10W		R739,740			RK73GB2A101J	CHIP R 100 J 1/10W	
R643			RK73GB2A223J	CHIP R 22K J 1/10W		R742			RK73GB2A101J	CHIP R 100 J 1/10W	
R644			RK73GB2A101J	CHIP R 100 J 1/10W		R744-746			RK73GB2A101J	CHIP R 100 J 1/10W	
R645			RK73GB2A473J	CHIP R 47K J 1/10W		R747			RK73GB2A223J	CHIP R 22K J 1/10W	
R647			RK73GB2A222J	CHIP R 2.2K J 1/10W		R749			RK73GB2A223J	CHIP R 22K J 1/10W	
R648			RK73GB2A473J	CHIP R 47K J 1/10W		R750			RK73GB2A515J	CHIP R 5.1M J 1/10W	K1K2M1
R649			RK73GB2A101J	CHIP R 100 J 1/10W		R750			RK73GB2A515J	CHIP R 5.1M J 1/10W	E1E4
R650			RK73GB2A473J	CHIP R 47K J 1/10W		R751			RK73GB2A473J	CHIP R 47K J 1/10W	K1K2M1
R660			RK73EB2E102J	CHIP R 1.0K J 1/4W		R751			RK73GB2A473J	CHIP R 47K J 1/10W	E1E4
R661			RK73EB2E222J	CHIP R 2.2K J 1/4W		R752,753			RK73GB2A101J	CHIP R 100 J 1/10W	K1K2M1
R662			RK73EB2E101J	CHIP R 100 J 1/4W		R752,753			RK73GB2A101J	CHIP R 100 J 1/10W	E1E4
R663			RK73EB2E102J	CHIP R 1.0K J 1/4W		R754,755			RK73GB2A473J	CHIP R 47K J 1/10W	K1K2M1
R664			RK73EB2E101J	CHIP R 100 J 1/4W		R754,755			RK73GB2A473J	CHIP R 47K J 1/10W	E1E4
R665			RK73EB2E102J	CHIP R 1.0K J 1/4W		R756			RK73GB2A101J	CHIP R 100 J 1/10W	K1K2M1
R666,667			RK73EB2E101J	CHIP R 100 J 1/4W		R756			RK73GB2A101J	CHIP R 100 J 1/10W	E1E4
R668,669			RK73EB2E102J	CHIP R 1.0K J 1/4W		R757			RK73GB2A473J	CHIP R 47K J 1/10W	K1K2M1
R680			RK73GB2A223J	CHIP R 22K J 1/10W		R757			RK73GB2A473J	CHIP R 47K J 1/10W	E1E4
R681			RK73GB2A101J	CHIP R 100 J 1/10W		R758			RK73GH2A104D	CHIP R 100K D 1/10W	K1K2M1
R683,684			RK73GB2A101J	CHIP R 100 J 1/10W		R758			RK73GH2A104D	CHIP R 100K D 1/10W	E1E4
R685			RK73GB2A223J	CHIP R 22K J 1/10W		R762-764			RK73GB2A473J	CHIP R 47K J 1/10W	K1K2M1
R686			RK73GB2A101J	CHIP R 100 J 1/10W		R762-764			RK73GB2A473J	CHIP R 47K J 1/10W	E1E4
R687			RK73GB2A223J	CHIP R 22K J 1/10W		R767			RK73GB2A223J	CHIP R 22K J 1/10W	
R688,689			RK73GB2A101J	CHIP R 100 J 1/10W		R768			RK73GB2A333J	CHIP R 33K J 1/10W	K1K2M1
R700			RK73GB2A102J	CHIP R 1.0K J 1/10W		R768			RK73GB2A333J	CHIP R 33K J 1/10W	E1E4
R701			RK73GB2A101J	CHIP R 100 J 1/10W		W100			R92-2053-05	CHIP R 0 OHM J 1/8W	K2K3M1
R704			RK73GB2A223J	CHIP R 22K J 1/10W		W100			R92-2053-05	CHIP R 0 OHM J 1/8W	M2E1E2
R705			RK73GB2A101J	CHIP R 100 J 1/10W		W100			R92-2053-05	CHIP R 0 OHM J 1/8W	E3E4E5

K1 : KDC-X492 **K2** : KDC-MP438U **K3** : KDC-MP408U **M1** : KDC-MP5539U
M2 : KDC-MP5039U **E1** : KDC-W5541U **E2** : KDC-W5041UA **E3** : KDC-W5041UG
E4 : KDC-W5641UY **E5** : KDC-W5141UAY **E6** : KDC-W5141UGY

△Indicates safety critical components.

PARTS LIST

ELECTRIC UNIT (X34-577x-xx)

Ref. No.	Add	New	Parts No.	Description	Destination	Ref. No.	Add	New	Parts No.	Description	Destination
W100			R92-2053-05	CHIP R 0 OHM J 1/8W	E6	IC700		*	92CD28AFG	MICROCONTROLLER IC	
W140			R92-1252-05	CHIP R 0 OHM J 1/16W	E1E2E3	IC750			341S2094	MICROPROCESSOR IC	K1K2M1
W140			R92-1252-05	CHIP R 0 OHM J 1/16W	E4E5E6	IC750			341S2094	MICROPROCESSOR IC	E1E4
W321			R92-2053-05	CHIP R 0 OHM J 1/8W		Q10			KTA1046-P	TRANSISTOR	
W500			R92-1252-05	CHIP R 0 OHM J 1/16W	K3M1M2	Q11			KRA303-P	DIGITAL TRANSISTOR	
W500			R92-1252-05	CHIP R 0 OHM J 1/16W	E1E2E3	Q12			KRC403-P	DIGITAL TRANSISTOR	
W500			R92-1252-05	CHIP R 0 OHM J 1/16W	E4E5E6	Q20			KTA1046-P	TRANSISTOR	
W501,502			R92-1252-05	CHIP R 0 OHM J 1/16W	K1K2	Q21			2SC4081	TRANSISTOR	
W705			R92-1252-05	CHIP R 0 OHM J 1/16W		Q22			2SA1576A	TRANSISTOR	
						Q23			KRC403-P	DIGITAL TRANSISTOR	
D1			S2V60-5009F46	DIODE		Q30			KTA1046-P	TRANSISTOR	
D20			RB160L-40	DIODE		Q31			2SC4081	TRANSISTOR	
D21			UDZW5.6(B)	ZENER DIODE		Q32			KRA303-P	DIGITAL TRANSISTOR	
D30		*	UDZW8.2(B)	ZENER DIODE		Q33			KRC403-P	DIGITAL TRANSISTOR	
D40		*	UDZW12(B)	ZENER DIODE		Q40			KTA1046-P	TRANSISTOR	
D50		*	UDZW20(B)	ZENER DIODE		Q41			2SC4081	TRANSISTOR	
D60			RB060M-30	DIODE		Q42			KRA303-P	DIGITAL TRANSISTOR	
D100		*	UDZW12(B)	ZENER DIODE	K1	Q43			KRC403-P	DIGITAL TRANSISTOR	
D101			UDZW5.6(B)	ZENER DIODE	K1	Q50			2SB1184(Q,R)	TRANSISTOR	
D102			1SR154-400	DIODE	K1	Q51			2SC4081	TRANSISTOR	
D103			DAP202U	DIODE	K1	Q100			2SB1443	TRANSISTOR	K1
D121,122			UDZW6.8(B)	ZENER DIODE		Q101			2SC4081	TRANSISTOR	K1
D123		*	UDZW6.2(B)	ZENER DIODE		Q103			2SC4081	TRANSISTOR	K1
D140,141			1SR154-400	DIODE		Q104			KRA303-P	DIGITAL TRANSISTOR	K1
D142			1SS355	DIODE		Q105			KRC403-P	DIGITAL TRANSISTOR	K1
D150,151			1SR154-400	DIODE		Q120			2SC4081	TRANSISTOR	
D160			UDZW4.7(B)	ZENER DIODE		Q122,123			2SC4081	TRANSISTOR	
D190		*	UDZW6.2(B)	ZENER DIODE		Q140			2SB1188(Q,R)	TRANSISTOR	
D400			DAP202U	DIODE		Q141			2SA1576A	TRANSISTOR	
D410			DAP202U	DIODE	K1K2M1	Q142			RT1P141M	TRANSISTOR	
D410			DAP202U	DIODE	M2	Q143			RT1N144M	TRANSISTOR	
D440-442			UDZW6.8(B)	ZENER DIODE		Q143			RT1N144M	TRANSISTOR	
D443		*	UDZW6.2(B)	ZENER DIODE		Q150			2SB1188(Q,R)	TRANSISTOR	K1K2K3
D448		*	UDZW6.2(B)	ZENER DIODE		Q150			2SB1188(Q,R)	TRANSISTOR	M1M2
D451-453			UDZW6.8(B)	ZENER DIODE		Q151			RT1N144M	TRANSISTOR	K1K2K3
D482-484			DAP202U	DIODE		Q151			RT1N144M	TRANSISTOR	M1M2
D501			DAP202U	DIODE		Q170			KRC404-P	DIGITAL TRANSISTOR	
D700,701			AVRL1613R3FTA	VARIATOR		Q320			2SB1689	TRANSISTOR	
IC10			M5237ML-CF0J	ANALOGUE IC		Q321			KRC403-P	DIGITAL TRANSISTOR	
IC20			R1114N331B-TR	ANALOGUE IC (3.3V LF)		Q367,368			KRC410-P	DIGITAL TRANSISTOR	K1K2
IC60			BD9781HFP	ANALOGUE IC		Q400			KRA303-P	DIGITAL TRANSISTOR	
IC100			TA75S558F-F	ANALOGUE IC	K1	Q401,402			KRC410-P	DIGITAL TRANSISTOR	
IC230		*	STMP52151STR	MOS-IC		Q410			KRA303-P	DIGITAL TRANSISTOR	K1K2M1
IC300			E-TDA7478AD	ANALOGUE IC	E1E2E3	Q410			KRA303-P	DIGITAL TRANSISTOR	M2
IC300			E-TDA7478AD	ANALOGUE IC	E4E5E6	Q411,412			KRC410-P	DIGITAL TRANSISTOR	K1K2M1
IC480			E-TDA7415CB	ANALOGUE IC		Q411,412			KRC410-P	DIGITAL TRANSISTOR	M2
IC500		*	KKZ11Z	ANALOGUE IC	K1K2	Q500			RT1N144M	TRANSISTOR	K3M1M2
IC500		*	KKZ12Z	ANALOGUE IC	K3M1M2	Q500			RT1N144M	TRANSISTOR	E1E2E3
IC500		*	KKZ12Z	ANALOGUE IC	E1E2E3	Q500			RT1N144M	TRANSISTOR	E4E5E6
IC500		*	KKZ12Z	ANALOGUE IC	E4E5E6	Q660			KRA307-P	DIGITAL TRANSISTOR	
IC600		*	30622MGPB58GP	MICROCONTROLLER IC		Q702			RT1N144M	TRANSISTOR	
IC601			XC6120N362N1	MOS-IC		Q703			2SB1689	TRANSISTOR	
IC603			74HC2G02DP	MOS-IC		Q704,705			RT1N144M	TRANSISTOR	
IC680		*	74AHCT08PW	MOS-IC		TH500			PRF18BE471QS2	POSITIVE RESISTOR	
IC682		*	74LVC08APW	MOS-IC		A320	2D		X86-4032-70	FRONT-END UNIT	E1E2E3

K1 : KDC-X492 **K2** : KDC-MP438U **K3** : KDC-MP408U **M1** : KDC-MP5539U
M2 : KDC-MP5039U **E1** : KDC-W5541U **E2** : KDC-W5041UA **E3** : KDC-W5041UG
E4 : KDC-W5641UY **E5** : KDC-W5141UAY **E6** : KDC-W5141UGY

△ Indicates safety critical components.

PARTS LIST

ELECTRIC UNIT (X34-577x-xx)

Ref. No.	A d d	N e w	Parts No.	Description	Desti- nation
A1	2D		X86-4032-70	FRONT-END UNIT	E4E5E6
A1	2D	*	X86-4160-11	FRONT-END UNIT	K1K2K3
A1	2D	*	X86-4160-11	FRONT-END UNIT	M1M2
MECHANISM ASSY (X92-6130-00) DXM-6E20W					
1	2B		A10-5328-31	CHASSIS	
2	1B		A10-5329-11	CHASSIS	
5	2B		D10-4910-13	ARM ASSY	
8	2A		D10-4911-23	LEVER ASSY	
10	2A		D10-4906-33	ARM	
11	2A		D10-4907-33	ARM	
12	3A		D10-4908-03	ARM	
13	3A		D10-4909-03	ARM	
14	3B		D10-4915-03	ARM	
15	2A		D10-4916-23	SLIDER	
16	3B		D10-4914-22	SLIDER	
17	2B		D10-4588-13	SLIDER	
18	2B		D10-4917-04	ARM	
19	2B		D10-4596-24	ARM	
22	2A		D13-2151-04	GEAR	
23	2B		D13-2152-04	GEAR	
24	3B		D13-2153-04	GEAR	
25	3B		D13-2154-04	GEAR	
26	3B		D13-2155-04	WORM	
27	2B		D13-2156-14	GEAR	
28	3B		D13-2157-04	GEAR	
29	2B		D13-2158-04	GEAR	
30	2B		D13-2168-04	GEAR	
31	3B		D13-2171-04	GEAR	
32	1B		D13-2400-13	RACK (GEAR)	
33	2A		D14-0759-04	ROLLER	
35	2B		D21-2382-04	SHAFT	
36	1A		D23-0954-04	RETAINER	
37	1B	*	D39-0271-05	DAMPER	
38	2B		G01-3072-04	EXTENSION SPRING	
39	2A		G01-3073-04	TORSION COIL SPRING	
40	2A		G01-3074-04	EXTENSION SPRING	
41	1B		G01-4615-04	EXTENSION SPRING	
42	2A		G01-3076-04	EXTENSION SPRING	
43	1B		G01-3077-14	EXTENSION SPRING	
44	2B		G02-1399-14	FLAT SPRING	
45	2B		G02-1547-14	FLAT SPRING	
51	1A		J22-0473-21	MOUNTING HARDWARE	
52	3B		J22-0474-12	MOUNTING HARDWARE	
53	1B		J22-0519-13	MOUNTING HARDWARE	
55	1A		J90-1138-41	GUIDE	
56	1B		J90-1023-03	GUIDE	
DPC1	3A		J86-0039-05	FPC (LEAD FREE)	
A	2B		N09-4460-15	TAPTITE SCREW (PT2X8)	
B	1B		N09-6317-05	TAPTITE SCREW (1.6X6.0)	
C	2B		N09-6004-15	MACHINE SCREW (M1.7X2.5)	
E	2B		N09-6007-15	MACHINE SCREW (M2X2)	
F	1A		N09-6051-15	TAPTITE SCREW (PT2X5)	

Ref. No.	A d d	N e w	Parts No.	Description	Desti- nation
G	2A		N19-2163-04	FLAT WASHER (1.6X6X0.25)	
H	1B		N39-2020-48	PAN HEAD MACHINE SCREW (M2X2)	
J	1B		N09-6108-15	TAPTITE SCREW (M2X3.5)	
K	3B		N09-6155-15	SEMS (TAPTITE SCREW) (PT2X6)	
DM1	3B		T42-1066-14	DC MOTOR (SPINDLE)	
DM2	2B		T42-1067-14	DC MOTOR (LOADING/SLED)	
DPU1	2B		X93-2130-01	OPTICAL PICKUP ASSY	

SPECIFICATIONS

■ Models for destination “K”

FM tuner section

Frequency range	
200kHz space	87.9MHz~107.9MHz
50kHz space (KDC-MP408U)	87.5MHz~108.0MHz
Usable sensitivity (S/N=30dB)	9.3dBf (0.8μV/75Ω)
Quieting Sensitivity (S/N=50dB)	15.2dBf (1.6μV/75Ω)
Frequency response (±3.0dB)	30Hz~15kHz
Signal to Noise ratio (MONO)	70dB
Selectivity (±400kHz)	≥80dB
Stereo separation (1kHz)	40dB

AM tuner section

Frequency range (10kHz space)	530kHz~1700kHz
Usable sensitivity (S/N=20dB)	28dBμ (25μV)

CD player section

Laser diode	GaAIs
Digital filter (D/A)	8 Times Over Sampling
D/A Converter	24Bit
Spindle speed	500~200rpm (CLV)
Wow & Flutter	Below Measurable Limit
Frequency response (±1dB)	10Hz~20kHz
Total harmonic distortion (1kHz)	
KDC-X492	0.008%
KDC-MP438U/MP408U	0.01dB
Signal to Noise ratio (1kHz)	
KDC-X492	110dB
KDC-MP438U/MP408U	108dB
Dynamic range	93dB
MP3 decode	Compliant with MPEG-1/2 Audio Layer-3
WMA decode	Compliant with Windows Media Audio
AAC decode	AAC-LC “.m4a” files

USB Interface

USB standard	USB1.1/2.0
Maximum supply current	500mA
File system	FAT16/32
MP3 decode	Compliant with MPEG-1/2 Audio Layer-3
WMA decode	Compliant with Windows Media Audio
AAC decode	AAC-LC “.m4a” files

Audio section

Maximum output power	50W x 4
Full Bandwidth Power (at less than 1% THD)	22W x 4
Speaker Impedance	4~8Ω
Tone action	
Bass	100Hz±8dB
Middle	1kHz±8dB
Treble	10kHz±8dB
Preout level/Load (CD)	
KDC-X492	4000mV/10kΩ

KDC-MP438U/MP408U	2500mV/10kΩ
Preout impedance	≤600Ω

Auxiliary input

Frequency response (±1dB)	20Hz~20kHz
Input Maximum Voltage	1200mV
Input Impedance	10kΩ

General

Operating voltage (11~16V allowable)	14.4V
Current consumption	10A
Installation Size (W x H x D)	182 x 53 x 155mm
	7-3/16 x 2-1/16 x 6-1/8inch
Weight	3.1lbs (1.40kg)

■ Models for destination “M”

FM tuner section

Frequency range	
200kHz space	87.9MHz~107.9MHz
50kHz space	87.5MHz~108.0MHz
Usable sensitivity (S/N=30dB)	9.3dBf (0.8μV/75Ω)
Quieting Sensitivity (S/N=50dB)	15.2dBf (1.6μV/75Ω)
Frequency response (±3.0dB)	30Hz~15kHz
Signal to Noise ratio (MONO)	70dB
Selectivity (±400kHz)	≥80dB
Stereo separation (1kHz)	40dB

AM tuner section

Frequency range	
10kHz space	530kHz~1700kHz
9kHz space	531kHz~1611kHz
Usable sensitivity (S/N=20dB)	28dBμ (25μV)

CD player section

Laser diode	GaAIs
Digital filter (D/A)	8 Times Over Sampling
D/A Converter	24Bit
Spindle speed	500~200rpm (CLV)
Wow & Flutter	Below Measurable Limit
Frequency response (±1dB)	10Hz~20kHz
Total harmonic distortion (1kHz)	0.008%
Signal to Noise ratio (1kHz)	110dB
Dynamic range	93dB
MP3 decode	Compliant with MPEG-1/2 Audio Layer-3
WMA decode	Compliant with Windows Media Audio
AAC decode	AAC-LC “.m4a” files

USB Interface

USB standard	USB1.1/2.0
Maximum supply current	500mA
File system	FAT16/32

SPECIFICATIONS

MP3 decode Compliant with MPEG-1/2 Audio Layer-3
WMA decode Compliant with Windows Media Audio
AAC decode AAC-LC “.m4a” files

Audio section

Maximum output power 50W x 4
Full Bandwidth Power (at less than 1% THD) 22W x 4
Speaker Impedance 4~8Ω
Tone action
 Bass 100Hz±8dB
 Middle 1kHz±8dB
 Treble 10kHz±8dB
Preout level/Load (CD) 2500mV/10kΩ
Preout impedance ≤600Ω

Auxiliary input

Frequency response (±1dB) 20Hz~20kHz
Input Maximum Voltage 1200mV
Input Impedance 10kΩ

General

Operating voltage (11~16V allowable) 14.4V
Current consumption 10A
Installation Size (W x H x D) 182 x 53 x 155mm
Weight 1.40kg

■ Models for destination “E”

FM tuner section

Frequency range (50kHz space) 87.5MHz~108.0MHz
Usable sensitivity (S/N=26dB) 0.7μV/75Ω
Quieting Sensitivity (S/N=46dB) 1.6μV/75Ω
Frequency response (±3.0dB) 30Hz~15kHz
Signal to Noise ratio (MONO) 65dB
Selectivity (±400kHz) ≥80dB
Stereo separation (1kHz) 35dB

MW tuner section

Frequency range (9kHz space) 531kHz~1611kHz
Usable sensitivity (S/N=20dB) 25μV

LW tuner section

Frequency range 153kHz~281kHz
Usable sensitivity (S/N=20dB) 45μV

CD player section

Laser diode GaAIs
Digital filter (D/A) 8 Times Over Sampling
D/A Converter 24Bit
Spindle speed 500~200rpm (CLV)
Wow & Flutter Below Measurable Limit
Frequency response (±1dB) 10Hz~20kHz
Total harmonic distortion (1kHz) 0.008%
Signal to Noise ratio (1kHz) 105dB
Dynamic range 93dB
MP3 decode Compliant with MPEG-1/2 Audio Layer-3
WMA decode Compliant with Windows Media Audio
AAC decode AAC-LC “.m4a” files

USB Interface

USB standard USB1.1/2.0
Maximum supply current 500mA
File system FAT16/32
MP3 decode Compliant with MPEG-1/2 Audio Layer-3
WMA decode Compliant with Windows Media Audio
AAC decode AAC-LC “.m4a” files

Audio section

Maximum output power 50W x 4
Full Bandwidth Power (at less than 1% THD) 30W x 4
Speaker Impedance 4~8Ω
Tone action
 Bass 100Hz±8dB
 Middle 1kHz±8dB
 Treble 10kHz±8dB
Preout level/Load (CD) 2500mV/10kΩ
Preout impedance ≤600Ω

Auxiliary input

Frequency response (±1dB) 20Hz~20kHz
Input Maximum Voltage 1200mV
Input Impedance 10kΩ

General

Operating voltage (11~16V allowable) 14.4V
Current consumption 10A
Installation Size (W x H x D) 182 x 53 x 155mm
Weight 1.40kg

KENWOOD follows a policy of continuous advancements in development. For this reason specifications may be changed without notice.

DANGER:

Please do not look at the laser beam directly during repair or operation check.

