

# Service Manual

**General Description**  
**Adjustment Procedures**  
**Block/Schematic Diagrams**  
**Exploded Views/Parts List**

Video Cassette Recorder



**NV-G7**  
PAL  
EN  
A  
EA  
BN  
BA

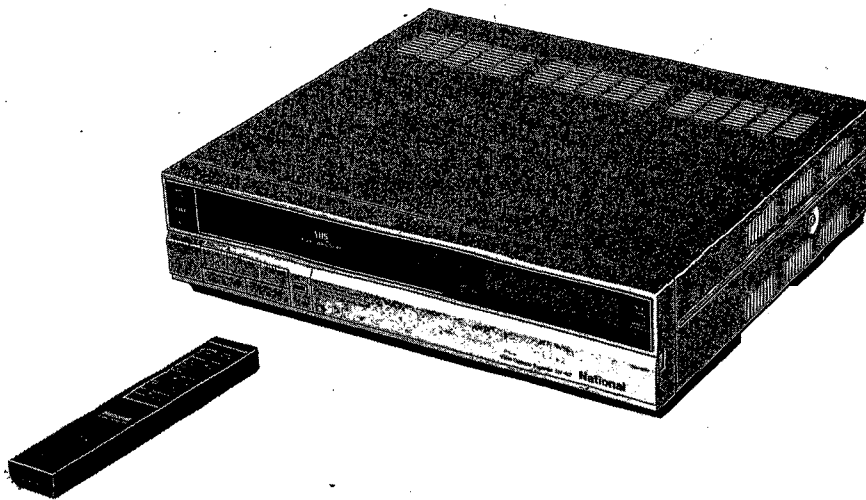

## SPECIFICATIONS

<b>Power Source:</b>	110~120/220~240 V AC 50/60 Hz (NV-G7EN) 240 V AC 50/60 Hz (NV-G7A) 230 V AC 50/60 Hz (NV-G7EA) 200/240 V AC 50/60 Hz (NV-G7BN) 220/240 V AC 50/60 Hz (NV-G7BA)	<b>TV Tuners:</b> VHF CH2~CH12 (NV-G7EN) CH0~CH11 (NV-G7A) CH1~CH9 (NV-G7EA) CH4~CH13 (NV-G7BA) UHF CH21~CH69 (NV-G7EN/A/EA/BN) CH21~CH68 (NV-G7BA)
<b>Power Consumption:</b>	Approx. 28 watts	<b>Output Level:</b> Video: VIDEO OUT connector (BNC) 1.0Vp-p, 75Ω terminated Audio: LINE OUT jack (Phono jack) -8dBV, less than 1kΩ
<b>Television System:</b>	CCIR: 625 lines, 50 fields PAL colour signal	<b>RF Modulated:</b> VHF CH3/4 (NV-G7EN) VHF CH0/1 (NV-G7A) VHF CH2/3 (NV-G7EA) 76 ± 3dBμ 75Ω unbalanced UHF CH36 ± 4 (NV-G7BN/BA) 73 ± 3dBμ 75Ω unbalanced
<b>Video Recording</b>	<b>System:</b> 2 rotary heads, helical scanning system <b>Luminance:</b> FM azimuth recording <b>Colour Signal:</b> Converted subcarrier phase shift recording	<b>Weight:</b> 6.7 kg
<b>Audio Track:</b>	1 track	<b>Dimensions:</b> 380(W)×99(H)×353(D)mm
<b>Tape Format:</b>	Tape width 12.7 mm high density tape	<b>Accessory Supplied:</b> 1 pc. DIN-RF Cable 1 pc. Wireless Remote Controller 1 pc. AC Plug Adaptor (NV-G7BN)
<b>Tape Speed:</b>	23.39mm/sec.	<b>Optional Accessories:</b> Video Cassette Tape: NV-E240 Approx. 344 m, 240 min. NV-E180 Approx. 258 m, 180 min. NV-E120 Approx. 174 m, 120 min. NV-E60 Approx. 88 m, 60 min.
<b>Record/Playback</b>	<b>Time:</b> 240 min. with NV-E240	
<b>FF/REW Time:</b>	Less than 5.5 min. with NV-E180	
<b>Heads:</b>	Video: 2 rotary heads Audio/Control/Audio Erase: 1 stationary head Erase: 1 full track erase	
<b>Input Level:</b>	Video: VIDEO IN connector (BNC) 1.0 Vp-p, 75Ω terminated Audio: LINE IN jack (Phono jack) More than -10dBV, 50kΩ	

Weight and dimensions shown are approximate.  
 Specifications are subject to change without notice.



**National**

**Matsushita Electric Trading Co., Ltd.**  
 P.O. Box 288, Central Osaka Japan

# SECTION 3

## BLOCK DIAGRAMS & SCHEMATIC DIAGRAMS

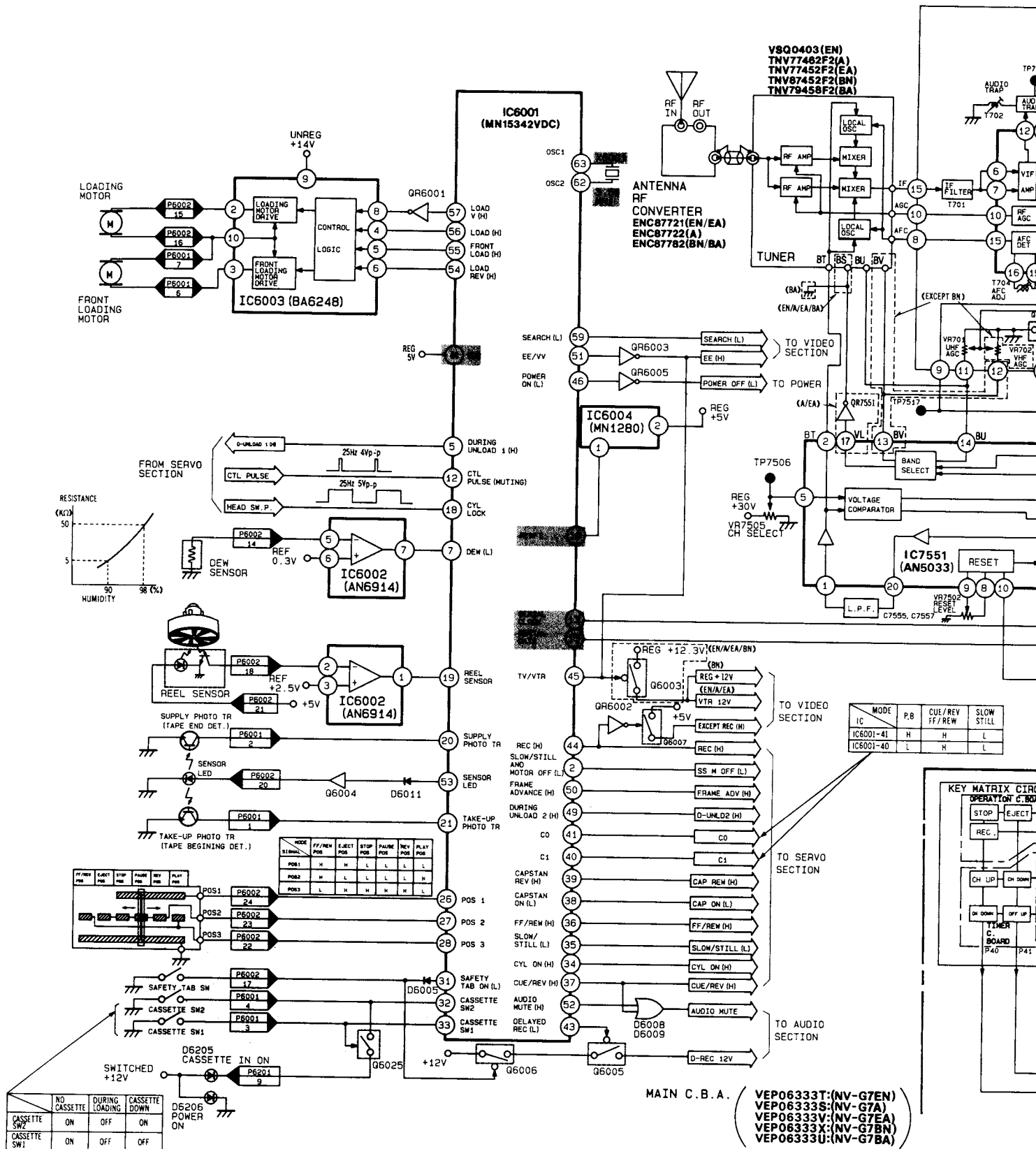
### 3-1. SYSTEM CONTROL/TIMER/TUNER & TV DEMODULATOR BLOCK DIAG



# K DIAGRAM

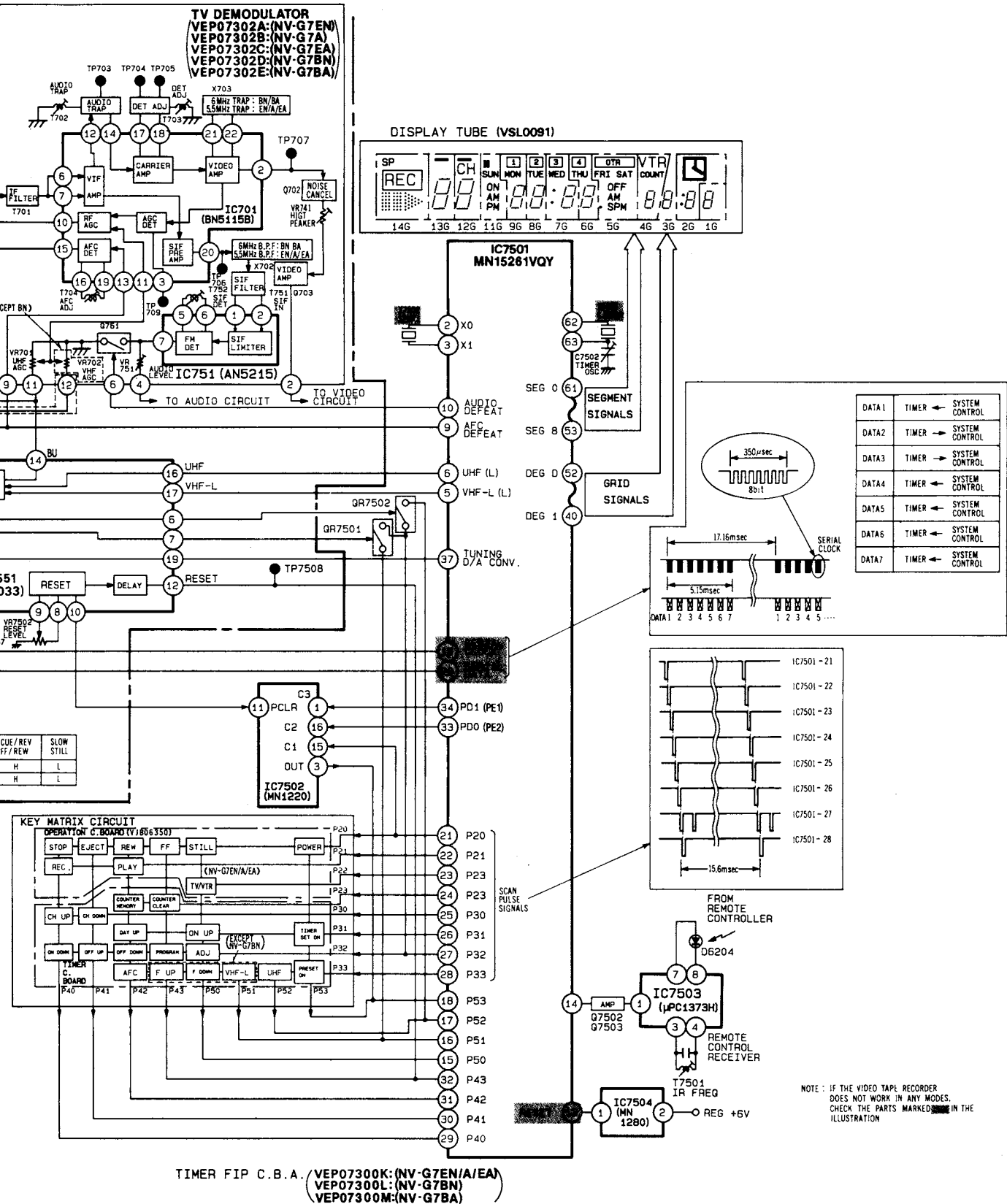

# 3-2. LUMINANCE & CHROMINANCE BLOCK DIAGRAM

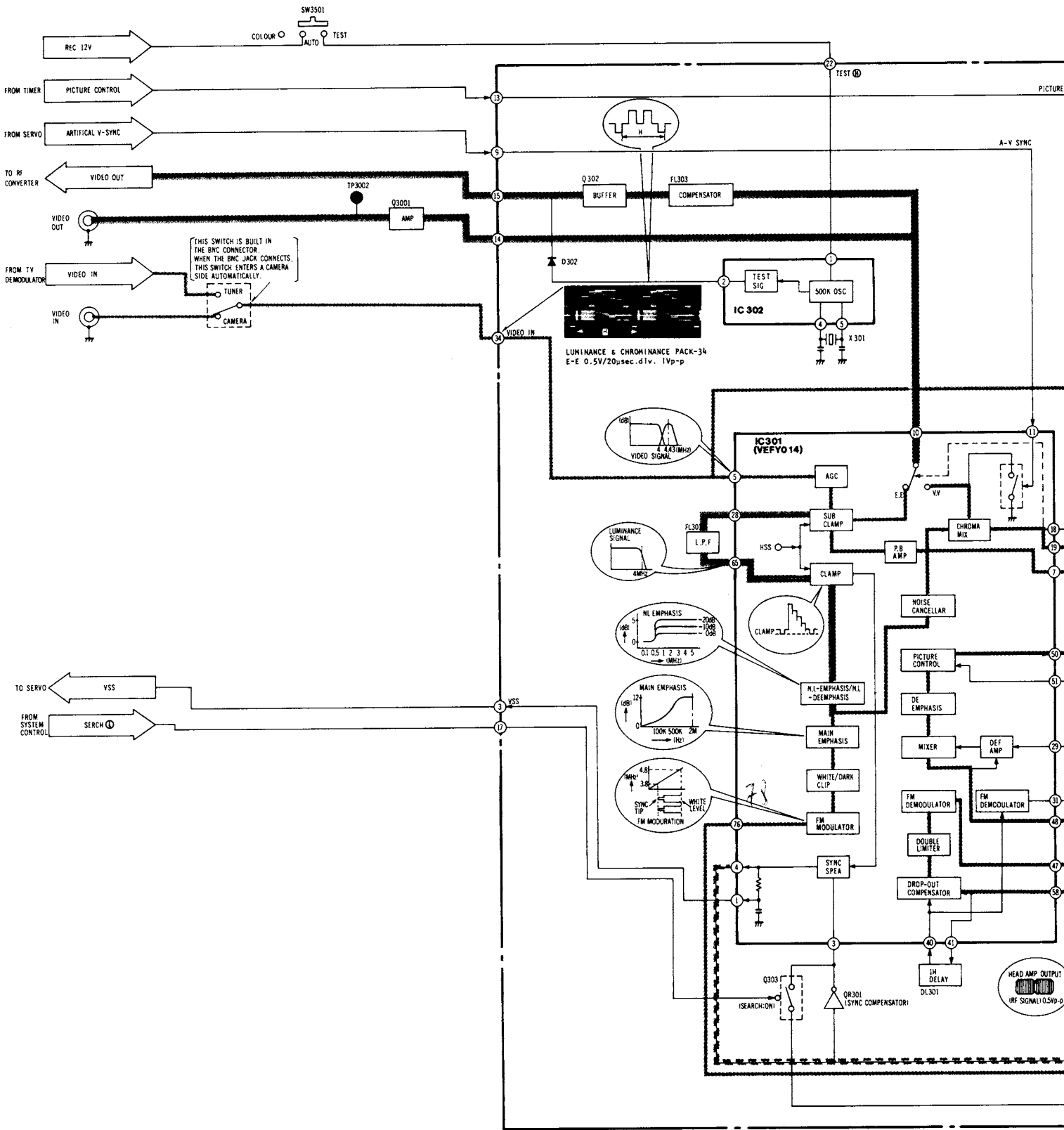

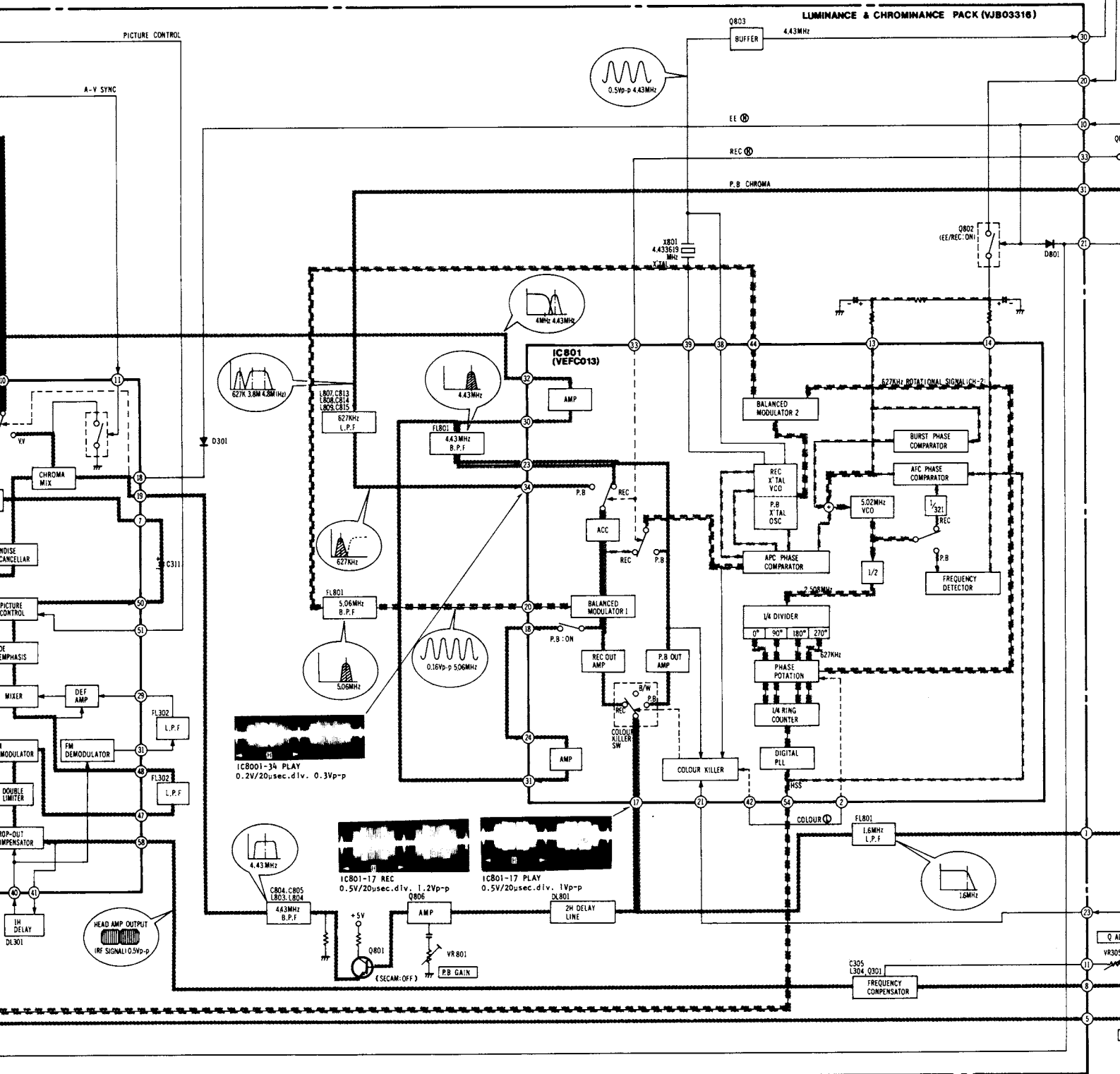

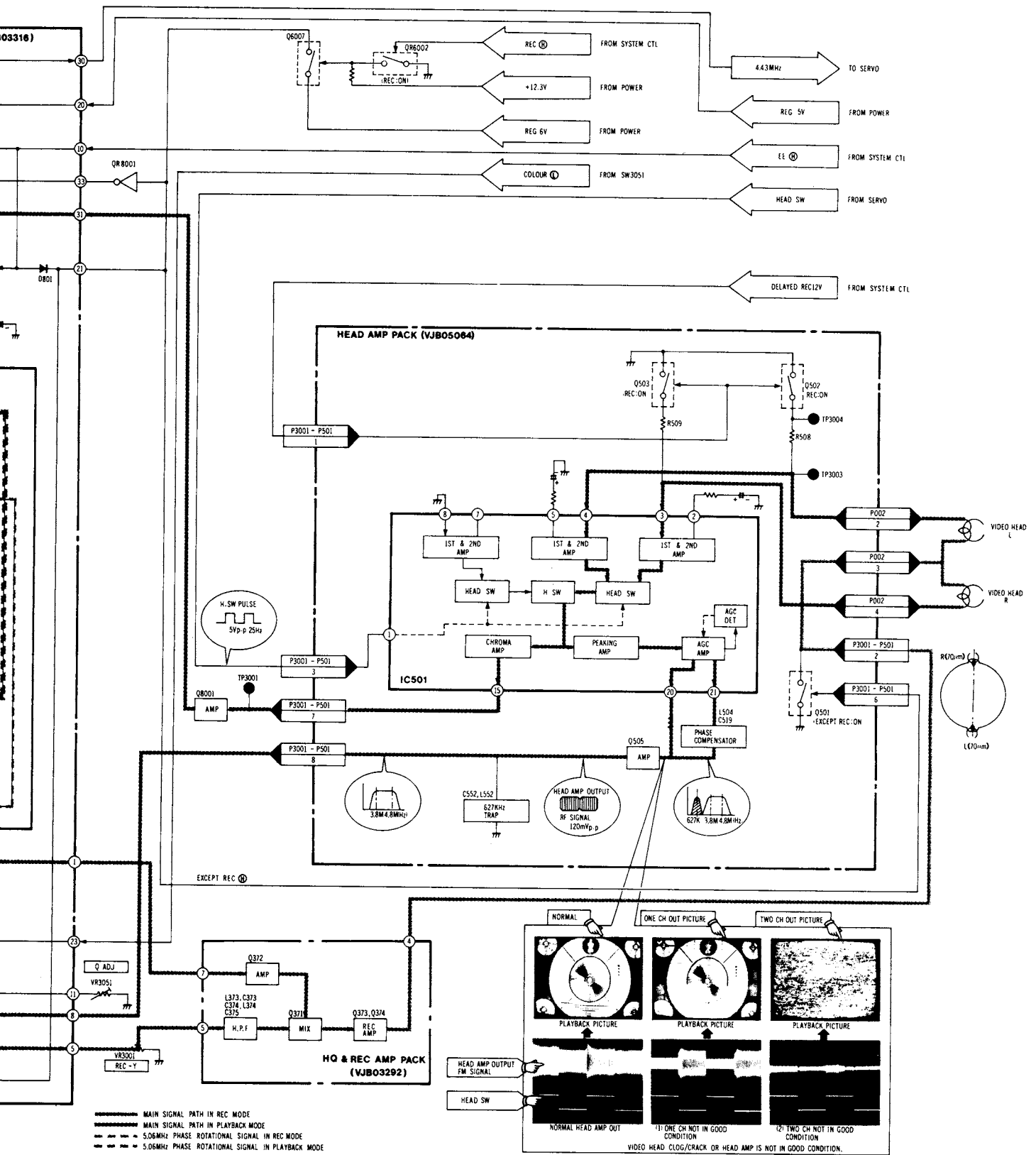

# 3-3. SERVO BLOCK DIAGRAM

CYLINDER SERVO CHECK POINT ● ~ ●  
 CAPSTAN SERVO CHECK POINT ● ~ ●

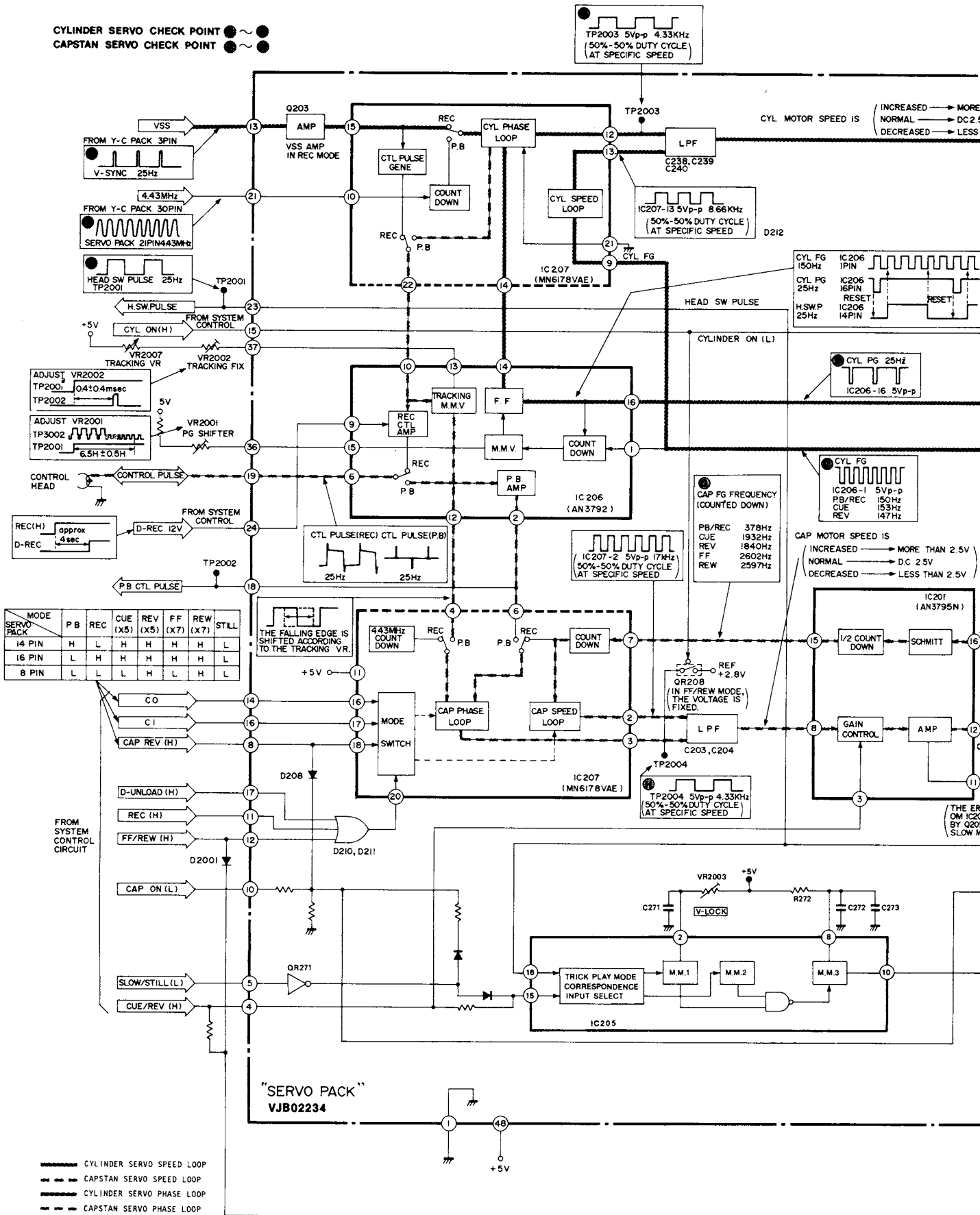

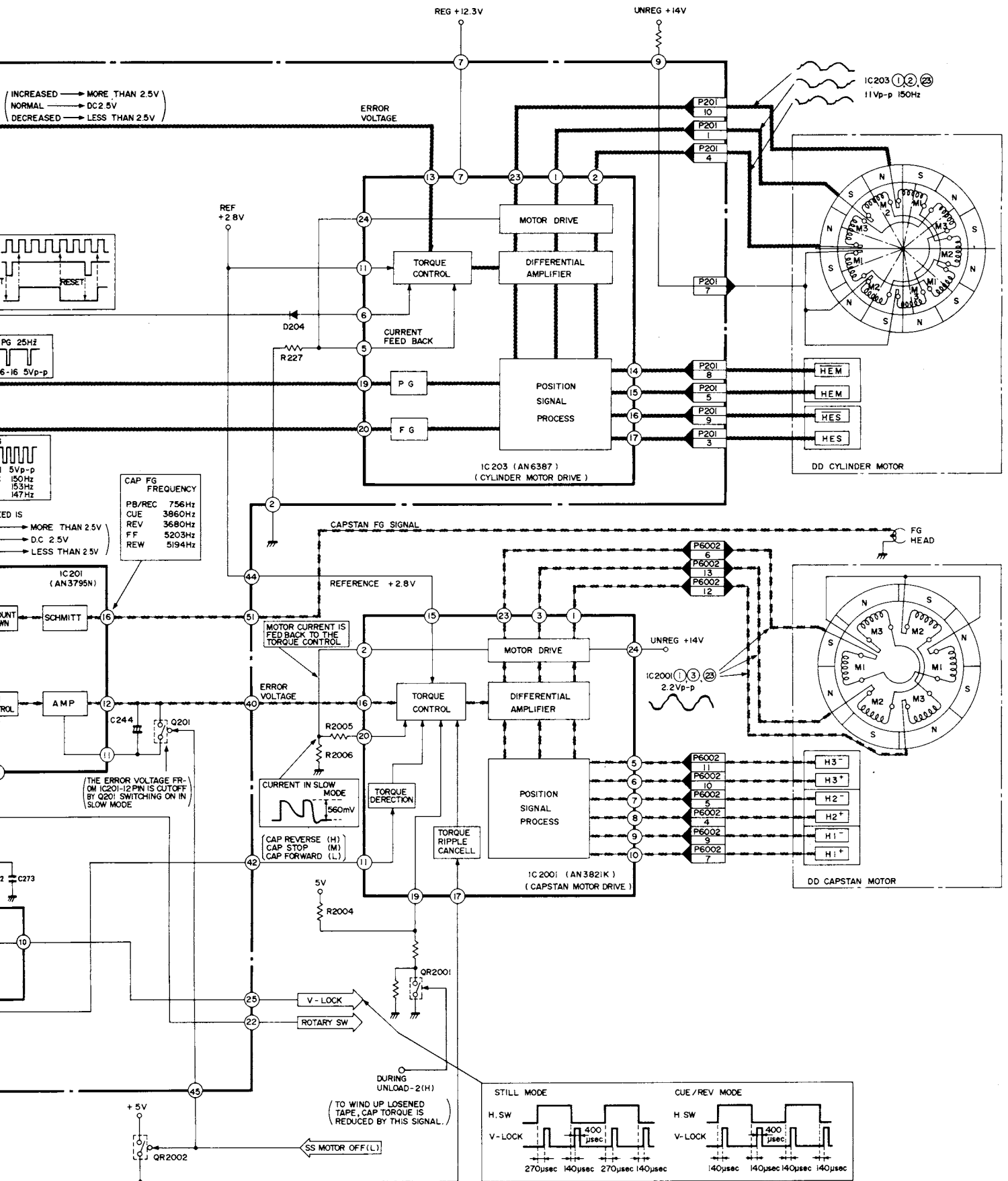



### 3-4. POWER SUPPLY SCHEMATIC DIAGRAM

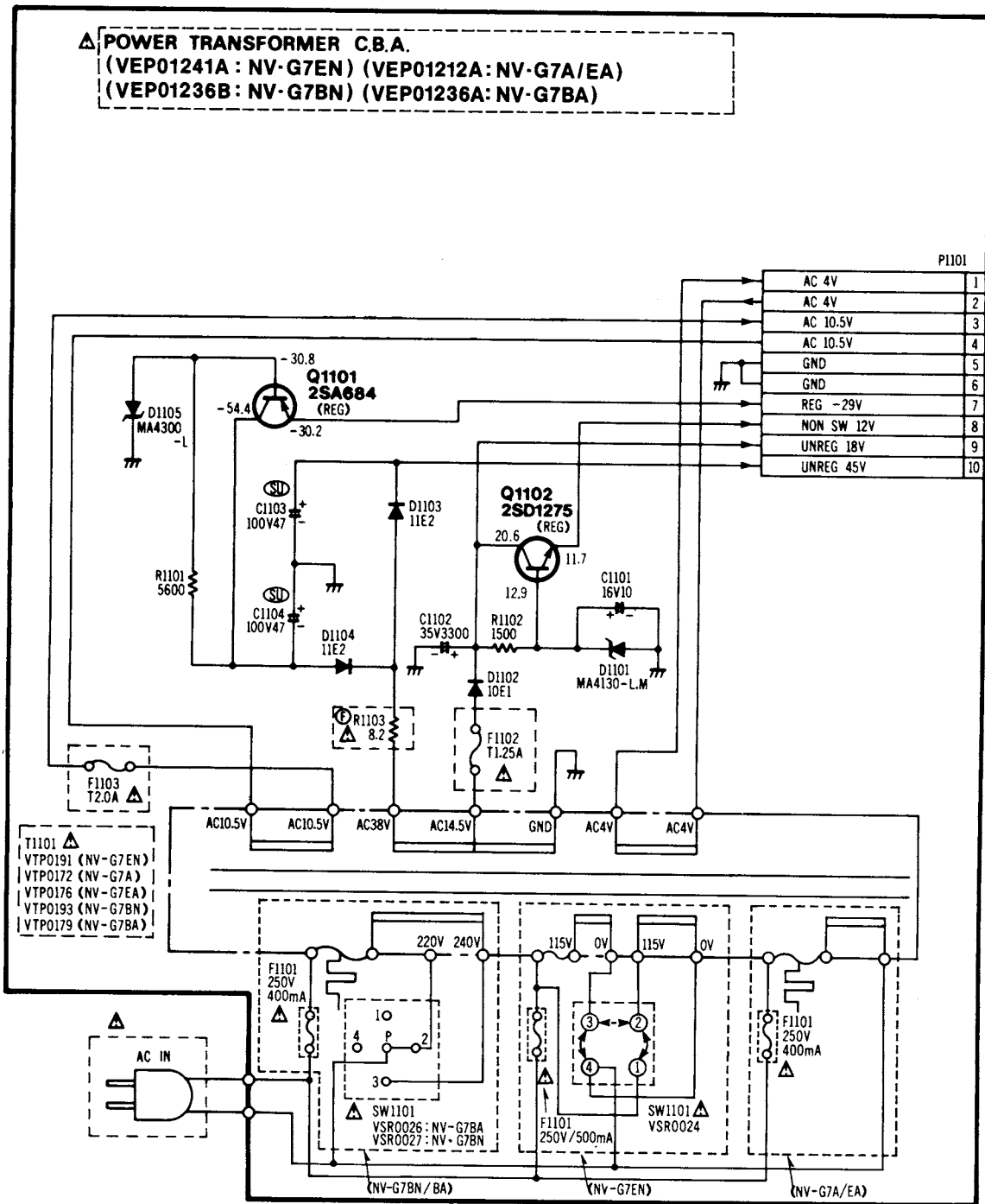

NOTE: THE MEASUREMENT MODE OF THE DC VOLTAGE ON THIS DIAGRAM IS STOP MODE.

Back Page:  
SERVO Section

**POWER SUPPLY SECTION IN MAIN C.B.A (VEP06333T : NV-G7EN) (VEP06333S : NV-G7A) (VEP06333V : NV-G7EA) (VEP06333X : NV-G7BN) (VEP06333U : NV-G7BA)**

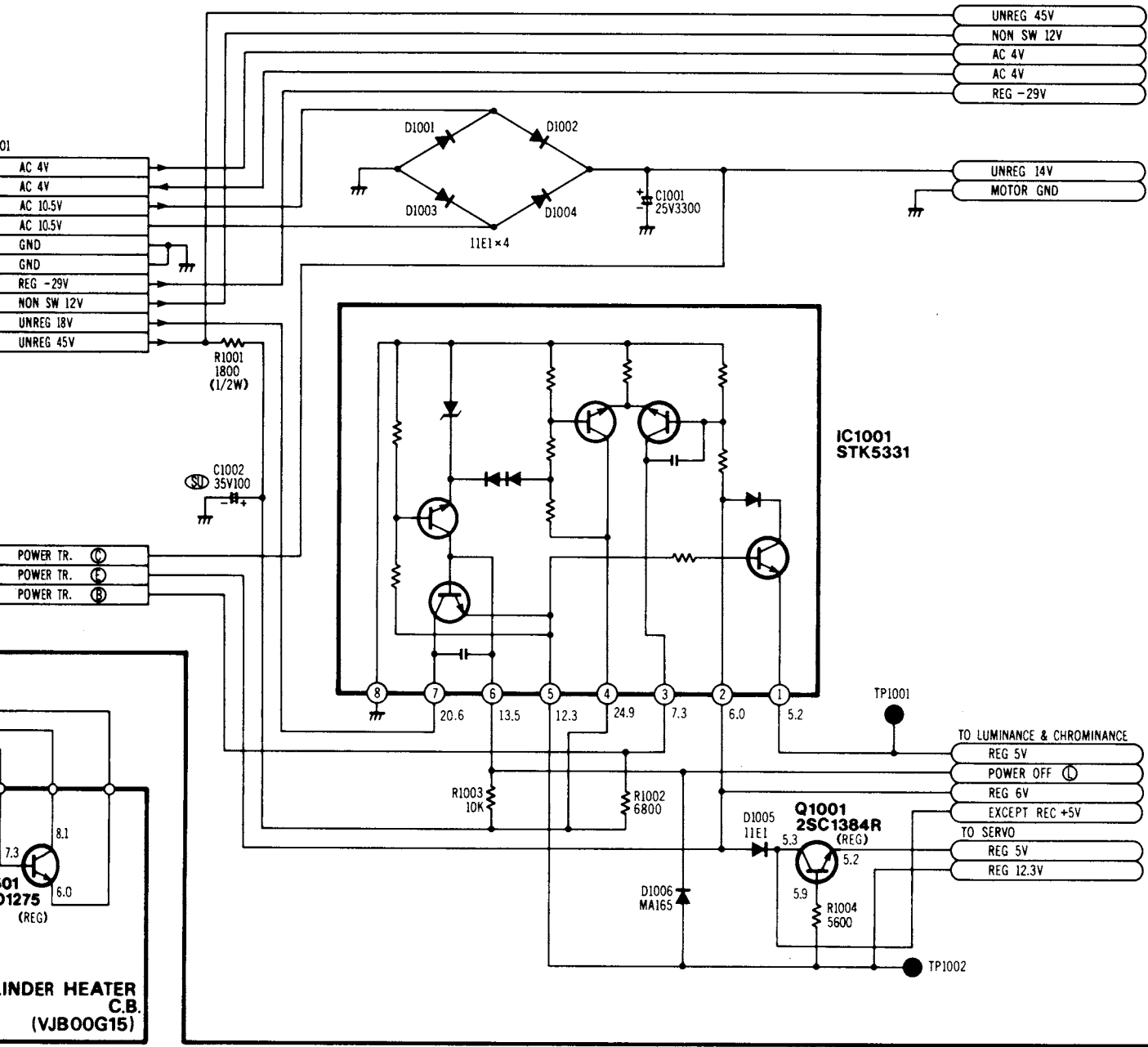

**IMPORTANT SAFETY NOTICE:**  
COMPONENTS IDENTIFIED WITH THE MARK  $\Delta$  HAVE THE SPECIAL CHARACTERISTICS FOR SAFETY.  
WHEN REPLACING ANY OF THESE COMPONENTS, USE ONLY THE SAME TYPE.

**NOTE:** DO NOT USE THE PART NUMBER SHOWN ON THIS DRAWING FOR ORDERING.  
THE CORRECT PART NUMBER IS SHOWN IN THE PARTS LIST, AND MAY BE SLIGHTLY DIFFERENT OR AMENDED SINCE THIS DRAWING WAS PREPARED.

# 3-7. SYSTEM CONTROL SCHEMATIC DIAGRAM

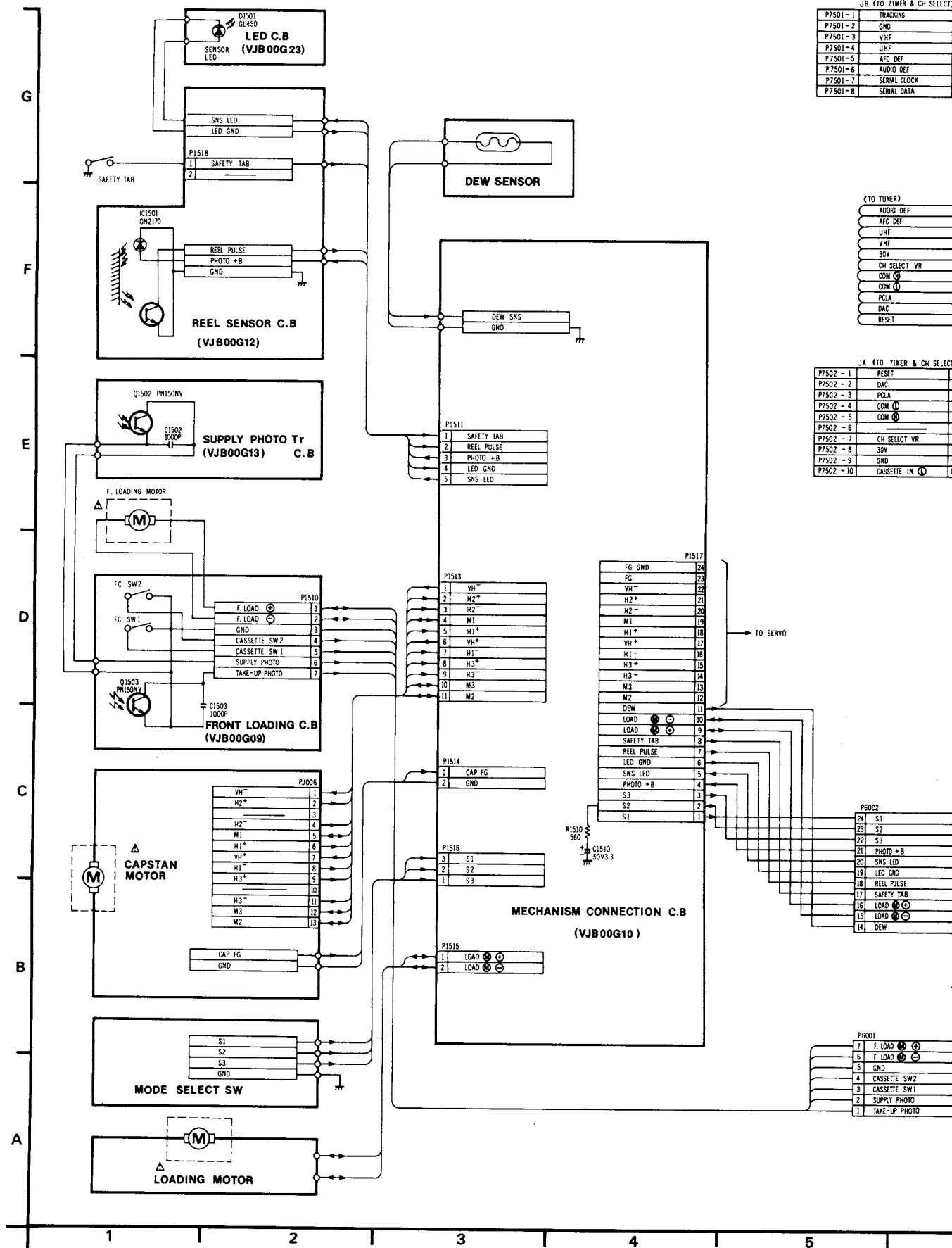

JB (TO TIMER & CH SELECT)

P7501-1	TRACKING
P7501-2	GND
P7501-3	VHF
P7501-4	UHF
P7501-5	AFC DEF
P7501-6	AUDIO DEF
P7501-7	SERIAL CLOCK
P7501-8	SERIAL DATA

(TO TUNER)

AUDIO DEF
AFC DEF
UHF
VHF
30V
CH SELECT VR
COM (1)
COM (2)
PCLA
DAC
RESET

JA (TO TIMER & CH SELECT)

P7502-1	RESET
P7502-2	DAC
P7502-3	PCLA
P7502-4	COM (1)
P7502-5	COM (2)
P7502-6	
P7502-7	CH SELECT VR
P7502-8	30V
P7502-9	GND
P7502-10	CASSETTE IN (1)

P6002

24	S1
23	S2
22	S3
21	PHOTO + B
20	SNS LED
19	LED GND
18	REEL PULSE
17	SAFETY TAB
16	LOAD (1)
15	LOAD (2)
14	DEW

P6001

7	F. LOAD (1)
6	F. LOAD (2)
5	GND
4	CASSETTE SW2
3	CASSETTE SW1
2	SUPPLY PHOTO
1	TAKE-UP PHOTO

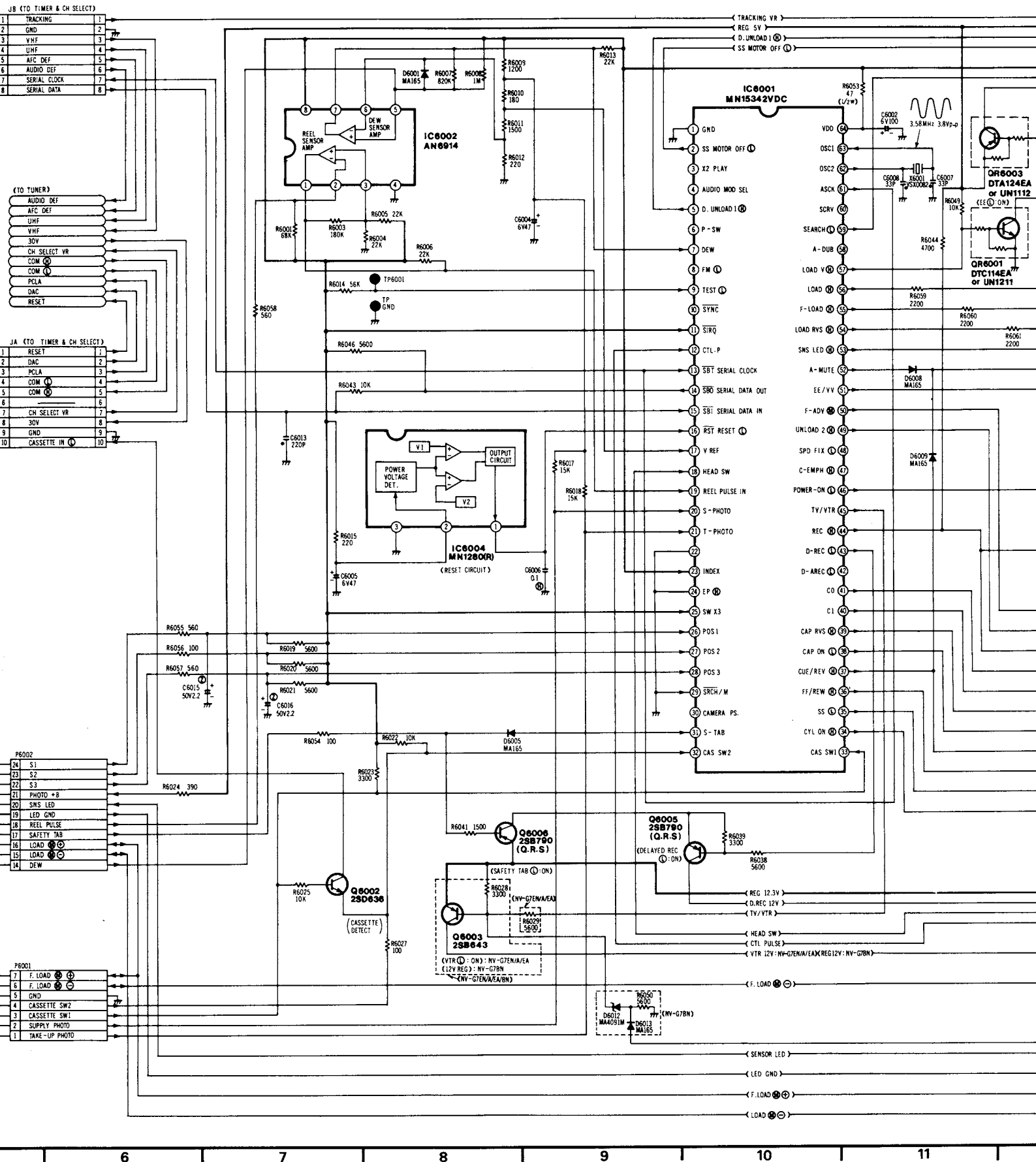

- JB (TO TIMER & CH SELECT)
- |   |              |   |
|---|--------------|---|
| 1 | TRACKING     | 1 |
| 2 | GND          | 2 |
| 3 | VHF          | 3 |
| 4 | UHF          | 4 |
| 5 | AFC DEF      | 5 |
| 6 | AUDIO DEF    | 6 |
| 7 | SERIAL CLOCK | 7 |
| 8 | SERIAL DATA  | 8 |

- (TO TUNER)
- |              |
|--------------|
| AUDIO DEF    |
| AFC DEF      |
| UHF          |
| YHF          |
| 30V          |
| CH SELECT VR |
| COM ①        |
| COM ②        |
| PCLA         |
| DAC          |
| RESET        |

- JA (TO TIMER & CH SELECT)
- |    |               |    |
|----|---------------|----|
| 1  | RESET         | 1  |
| 2  | DAC           | 2  |
| 3  | PCLA          | 3  |
| 4  | COM ①         | 4  |
| 5  | COM ②         | 5  |
| 6  |               | 6  |
| 7  | CH SELECT VR  | 7  |
| 8  | 30V           | 8  |
| 9  | GND           | 9  |
| 10 | CASSETTE IN ① | 10 |

- P6002
- |    |            |
|----|------------|
| 24 | S1         |
| 23 | S2         |
| 22 | S3         |
| 21 | PHOTO *8   |
| 20 | SNS LED    |
| 19 | LED GND    |
| 18 | REEL PULSE |
| 17 | SAFETY TAB |
| 16 | LOAD ①     |
| 15 | LOAD ②     |
| 14 | DEW        |

- P6001
- |   |               |
|---|---------------|
| 7 | F. LOAD ①     |
| 6 | F. LOAD ②     |
| 5 | GND           |
| 4 | CASSETTE SW2  |
| 3 | CASSETTE SW1  |
| 2 | SUPPLY PHOTO  |
| 1 | TAKE-UP PHOTO |

- TRACKING VR  
REG 5V  
D. UNLOAD ①  
SS MOTOR OFF ①

- IC6001 MN15342VDC
- |    |                     |
|----|---------------------|
| 1  | GND                 |
| 2  | SS MOTOR OFF ①      |
| 3  | X2 PLAY             |
| 4  | AUDIO MOD SEL       |
| 5  | D. UNLOAD ①         |
| 6  | P-SW                |
| 7  | DEW                 |
| 8  | FM ①                |
| 9  | TEST ①              |
| 10 | SYNC                |
| 11 | STRQ                |
| 12 | CTL.P               |
| 13 | SBT SERIAL CLOCK    |
| 14 | SBD SERIAL DATA OUT |
| 15 | SBI SERIAL DATA IN  |
| 16 | RST RESET ①         |
| 17 | V REF               |
| 18 | HEAD SW             |
| 19 | REEL PULSE IN       |
| 20 | S-PHOTO             |
| 21 | T-PHOTO             |
| 22 |                     |
| 23 | INDEX               |
| 24 | EP ①                |
| 25 | SW X3               |
| 26 | POS 1               |
| 27 | POS 2               |
| 28 | POS 3               |
| 29 | SRCH/M              |
| 30 | CAMERA PS.          |
| 31 | S-TAB               |
| 32 | CAS SW2             |

- IC6001 MN15342VDC (continued)
- |            |
|------------|
| VDO ④      |
| OSC1 ⑤     |
| OSC2 ⑥     |
| ASCK ⑦     |
| SCRV ⑧     |
| SEARCH ⑨   |
| A-DUB ⑩    |
| LOAD V ⑪   |
| LOAD ⑫     |
| F-LOAD ⑬   |
| LOAD RVS ⑭ |
| SNS LED ⑮  |
| A-MUTE ⑯   |
| EE/VV ⑰    |
| F-ADV ⑱    |
| UNLOAD 2 ⑲ |
| SPD FIX ⑳  |
| C-EMPH ㉑   |
| POWER-ON ㉒ |
| TV/VTR ㉓   |
| REC ㉔      |
| D-REC ㉕    |
| D-AREC ㉖   |
| CO ㉗       |
| C1 ㉘       |
| CAP RVS ㉙  |
| CAP ON ㉚   |
| CUE/REV ㉛  |
| FF/REW ㉜   |
| SS ㉝       |
| CYL ON ㉞   |
| CAS SW1 ㉟  |

- (F. LOAD ①)  
(SENSOR LED)  
(LED GND)  
(F. LOAD ②)  
(LOAD ③)

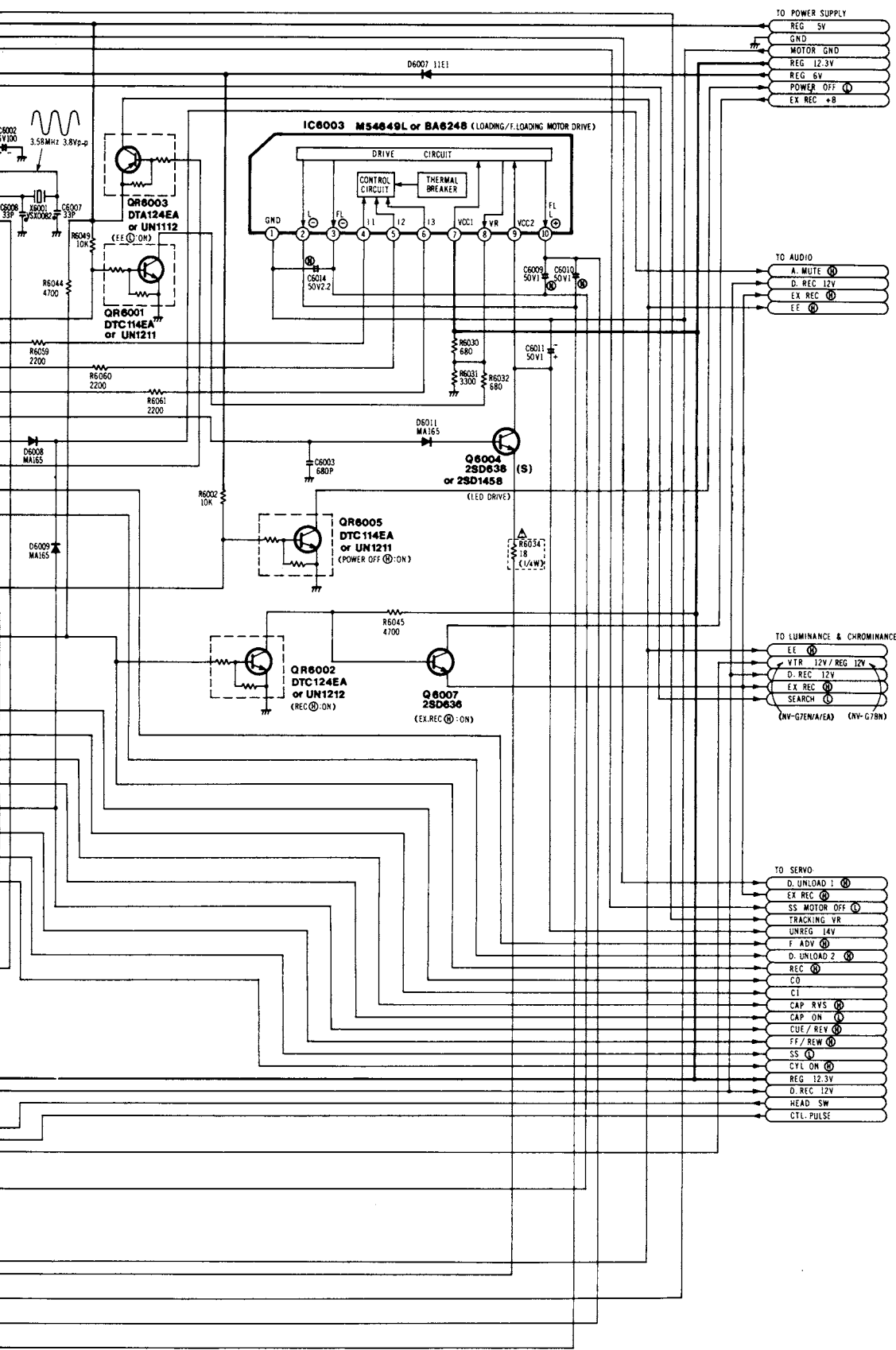

SYSTEM CONTROL SCHEMATIC	
<b>Transistor</b>	
Q1502	E-1
Q1503	D-1
Q6002	B-7
Q6003	B-8
Q6004	E-13
Q6005	C-9
Q6006	B-9
Q6007	D-13
<b>Transistor &amp; Resistor</b>	
QR6001	F-11
QR6002	D-12
QR6003	G-11
QR6005	E-13
<b>Integrated Circuit</b>	
IC1501	F-1
IC8001	G-10
IC6002	G-8
IC8003	G-12
IC8004	D-8
<b>Test Point</b>	
TP6001	F-8
TP GND	F-8
<b>Connector</b>	
PJ006	C-2
P1510	D-2
P1511	E-3
P1513	D-3
P1514	C-3
P1515	B-3
P1516	C-3
P1517	D-4
P1518	G-1
P6001	B-5
P6002	C-5
P6003	G-5
JA	E-5
JB	G-5

ADDRESS INFORMATION

**IMPORTANT SAFETY NOTICE:**  
COMPONENTS IDENTIFIED WITH THE MARK  $\Delta$  HAVE THE SPECIAL CHARACTERISTICS FOR SAFETY.  
WHEN REPLACING ANY OF THESE COMPONENTS, USE ONLY THE SAME TYPE.

NOTE: DO NOT USE THE PART NUMBER SHOWN ON THIS DRAWING FOR ORDERING.  
THE CORRECT PART NUMBER IS SHOWN IN THE PARTS LIST, AND MAY BE SLIGHTLY DIFFERENT OR AMENDED SINCE THIS DRAWING WAS PREPARED.

11 | 12 | 13 | 14 | 15

Next Page:  
SERVO Section

# 3-8. SERVO SCHEMATIC DIAGRAM

← CYLINDER SERV

← CAPSTAN SERVO

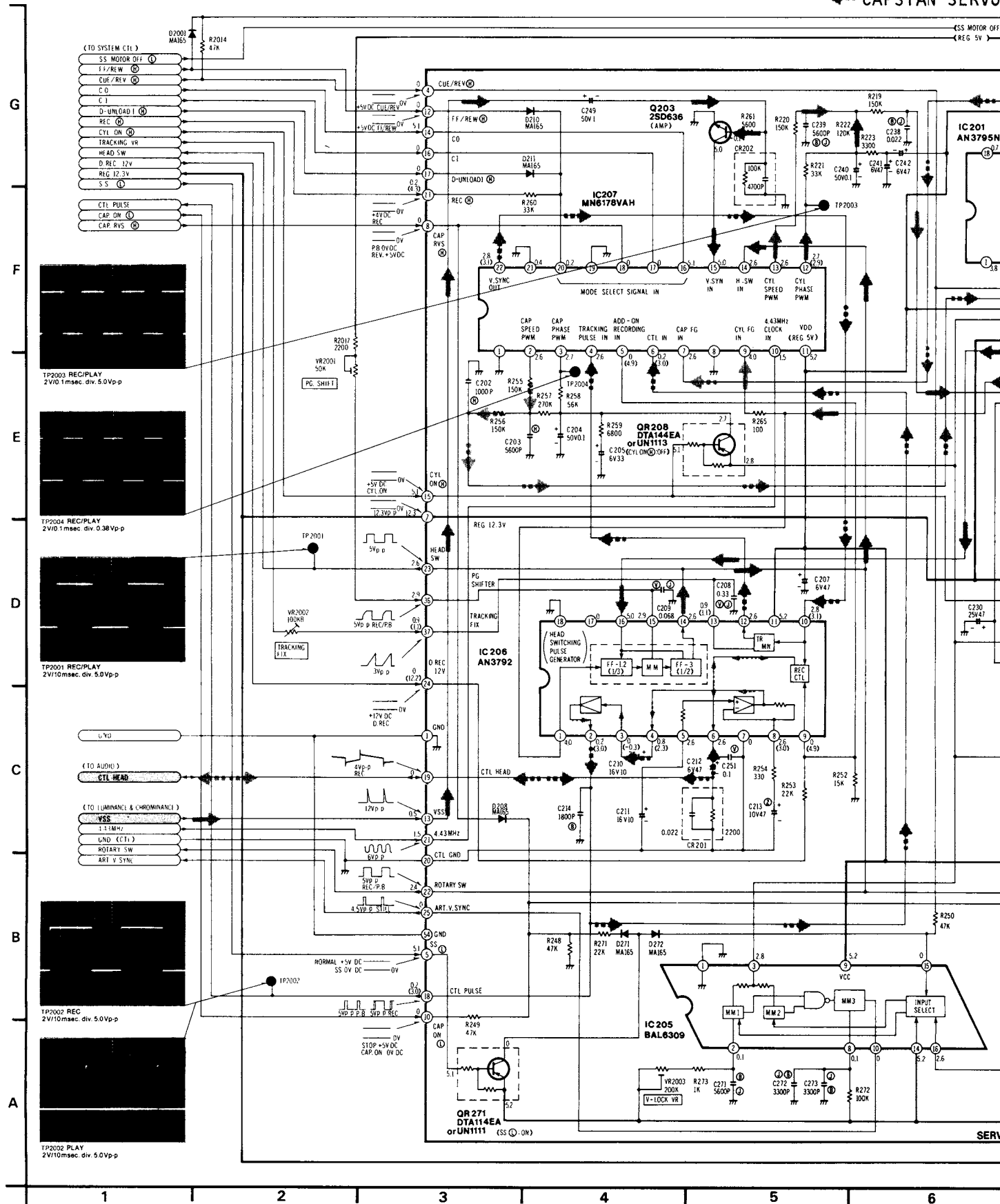

← CYLINDER SERVO SPEED LOOP  
 ← CAPSTAN SERVO SPEED LOOP

← CYLINDER SERVO PHASE LOOP  
 ← CAPSTAN SERVO PHASE LOOP

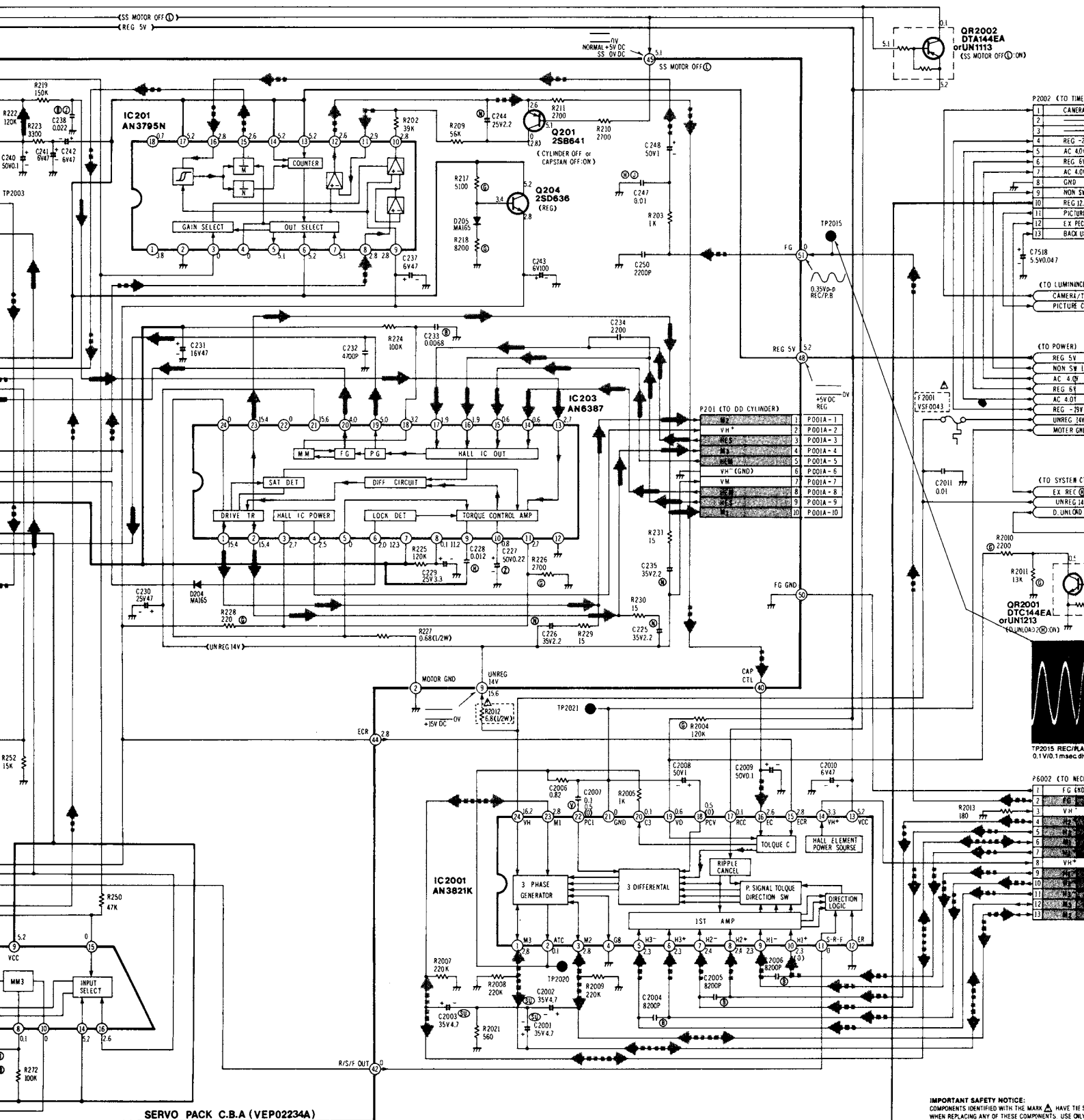

NOTE: THE MEASUREMENT MODE OF THE DC VOLTAGE IN THE BRACKETS ( ) ON THIS DIAGRAM IS RECORD MODE WITH PAL COLOUR SIGNAL.

THE MEASUREMENT MODE OF THE DC VOLTAGE OUT OF THE BRACKETS ON THIS DIAGRAM IS PLAYBACK MODE WITH PAL COLOUR SIGNAL.

IMPORTANT SAFETY NOTICE: COMPONENTS IDENTIFIED WITH THE MARK HAVE THE CORRECT PART NUMBER SHOWN IN IT. SLIGHTLY DIFFERENT OR AMENDED SINCETHE

NOTE: DO NOT USE THE PART NUMBER SHOWN ON THE CORRECT PART NUMBER IS SHOWN IN IT. SLIGHTLY DIFFERENT OR AMENDED SINCETHE

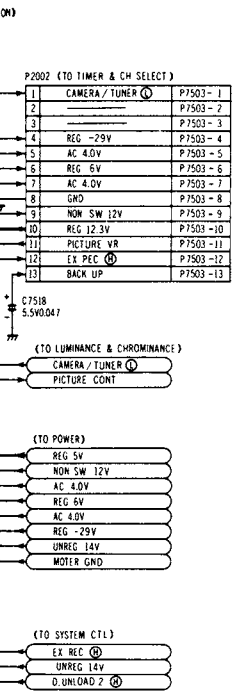

SERVO SCHEMATIC	
<b>Transistor</b>	
Q201	G-9
Q203	G-4
Q204	F-9
<b>Transistor &amp; Resistor</b>	
QR271	A-3
QR208	E-4
QR2001	D-12
QR2002	G-11
<b>Integrated Circuit</b>	
IC201	G-6
IC203	E-9
IC205	A-4
IC206	D-3
IC207	F-4
IC2001	B-8
<b>Test Point</b>	
TP2001	D-2
TP2002	B-2
TP2003	F-5
TP2004	E-4
TP2015	F-10
TP2020	B-9
TP2021	C-9
<b>Adjustment</b>	
VR2001	E-2
VR2002	D-2
VR2003	A-4
<b>Connector</b>	
P201	E-10
P2002	G-12
P6002	C-12

SERVO SECTION	
<b>Transistor &amp; Resistor</b>	
QR2001	B-7
QR2002	B-7
<b>Integrated Circuit</b>	
IC2001	C-7
<b>Test Point</b>	
TP2001	B-9
TP2002	B-8
TP2015	A-5
TP2020	C-7
TP2021	B-5
<b>Adjustment</b>	
VR2001	A-6
VR2002	A-7

ADDRESS INFORMATION

ADDRESS INFORMATION

ICs & TRANSISTORS INFORMATION

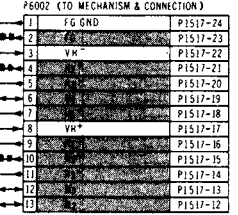
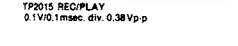
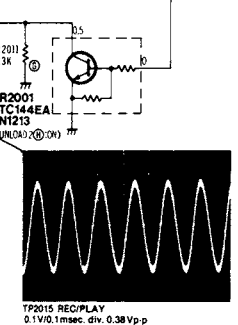
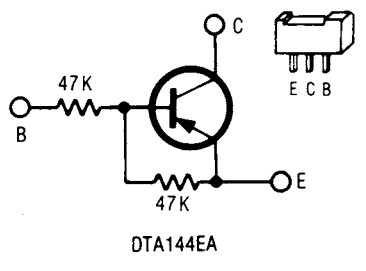
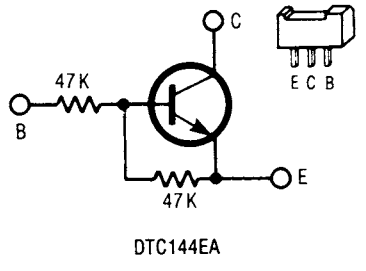
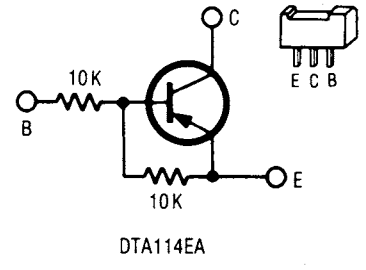
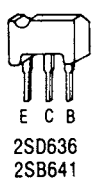
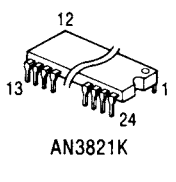
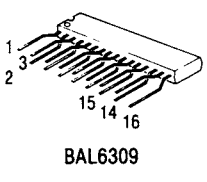
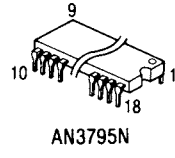
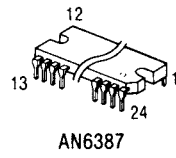
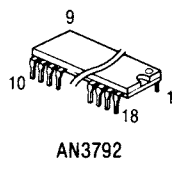
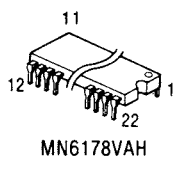

NOTE: THE MARK  $\Delta$  HAVE THE SPECIAL CHARACTERISTICS FOR SAFETY COMPONENTS. USE ONLY THE SAME TYPE.

NUMBER SHOWN ON THIS DRAWING FOR ORDERING. NUMBER IS SHOWN IN THE PARTS LIST, AND MAY BE MODIFIED SINCE THIS DRAWING WAS PREPARED.



# 3-11. LUMINANCE & CHROMINANCE SCHEMATIC DIAGRAM

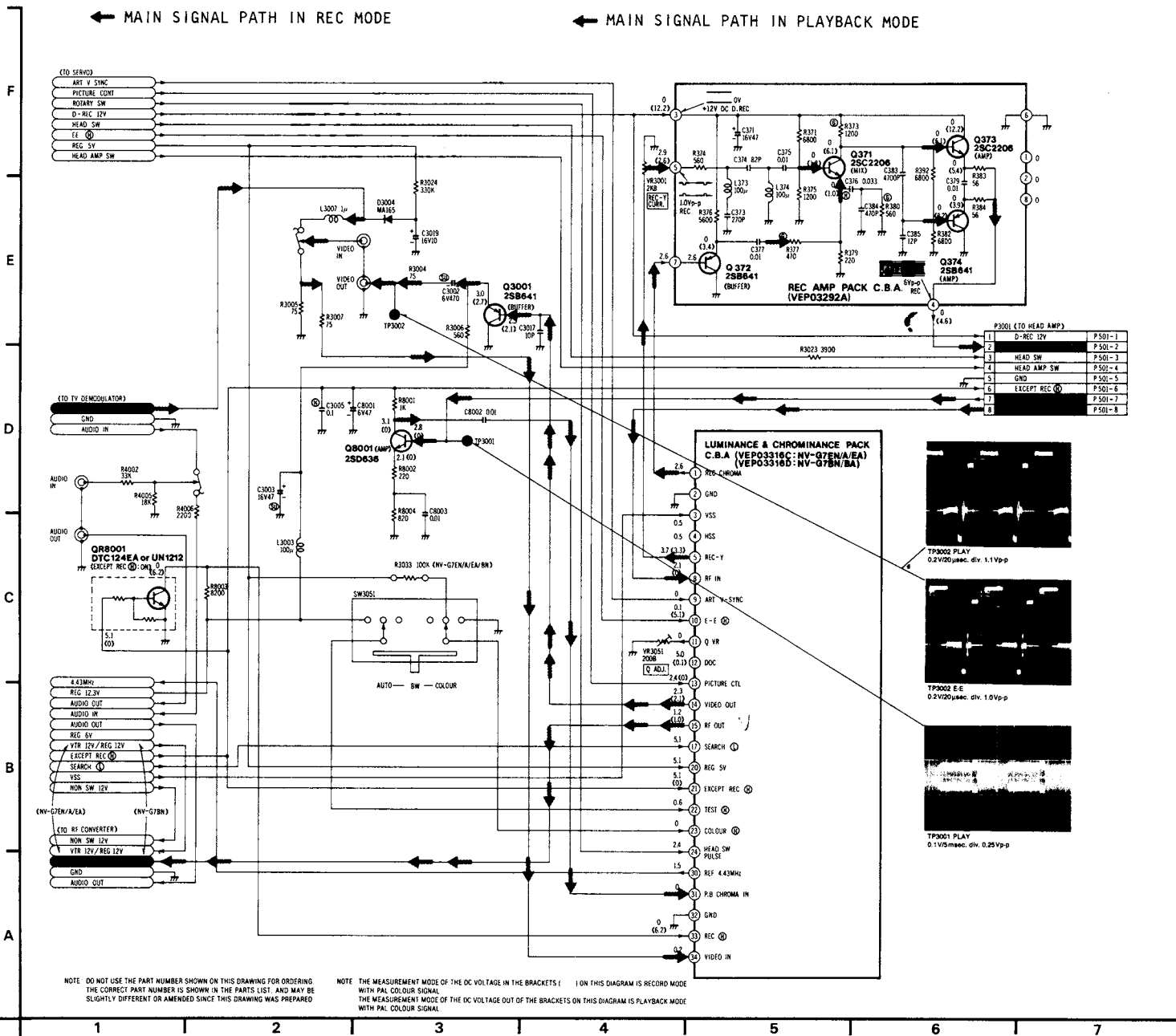

Back Page:  
SERVO Section

### 3-12. LUMINANCE & CHROMINANCE PACK SCHEMATIC DIAGRAM

**LUMINANCE & CHROMINANCE SCHEMATIC DIAGRAM**

Transistor	
Q371	F-6
Q372	E-5
Q373	F-6
Q374	E-6
Q3001	E-3
Q8001	D-3

Transistor & Resistor	
QR8001	C-1

Test Point	
TP3001	D-3
TP3002	E-3

Adjustment	
VR3001	E-4
VR3051	C-4

Connector	
P3001	F-5

ADDRESS INFORMATION

TO HEAD AMP)	P501-1
-REC 12V	P501-2
HEAD SW	P501-3
HEAD AMP SW	P501-4
VIDEO	P501-5
SCRIPT REC (Q)	P501-6
	P501-7
	P501-8

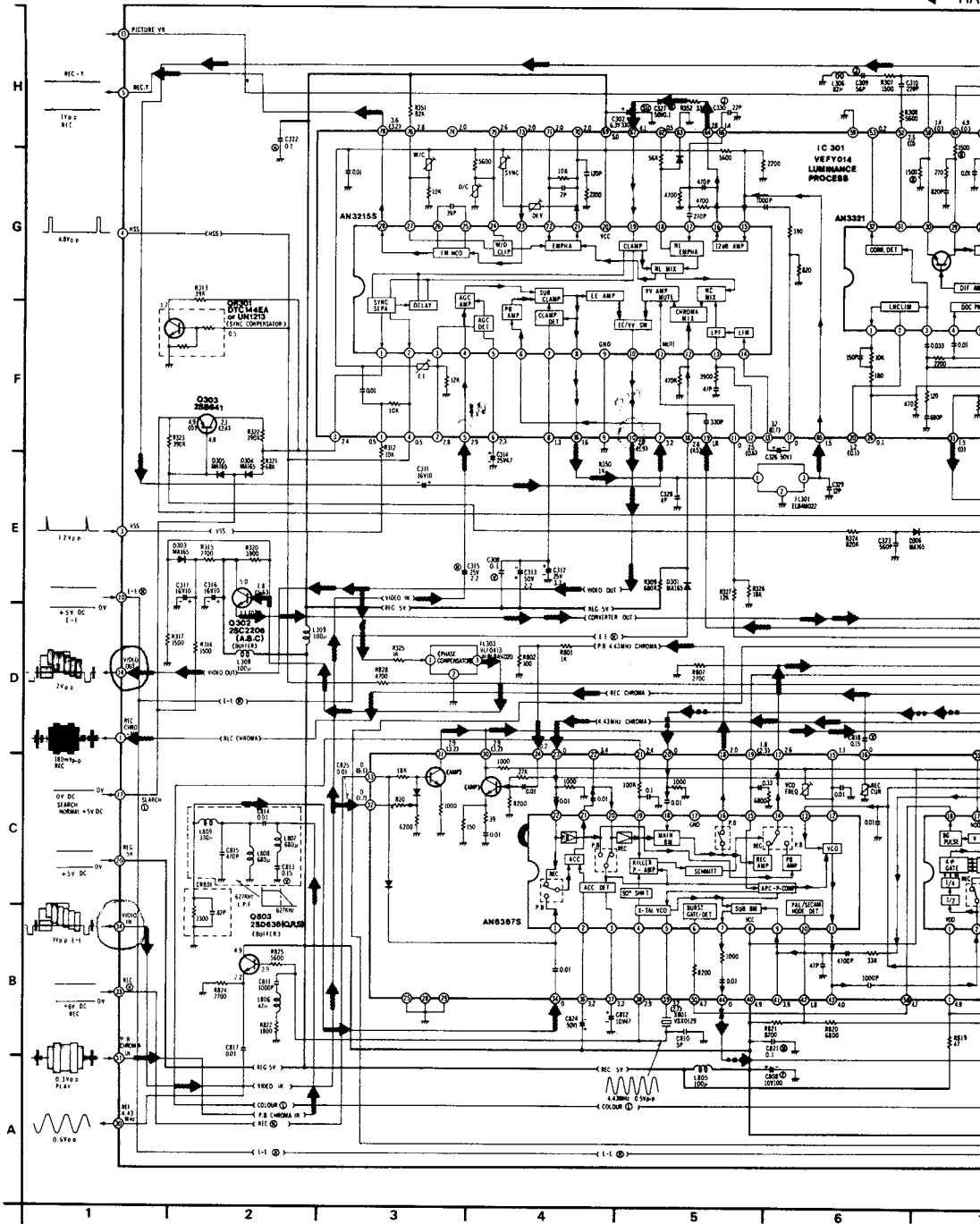

RAM ← MAIN SIGNAL PATH IN REC MODE      ◀• 5.06MHz PHASE ROTATIONAL SIGNAL PATH IN REC MODE  
 ← MAIN SIGNAL PATH IN PLAYBACK MODE      ◀• 5.06MHz PHASE ROTATIONAL SIGNAL PATH IN PLAYBACK MODE

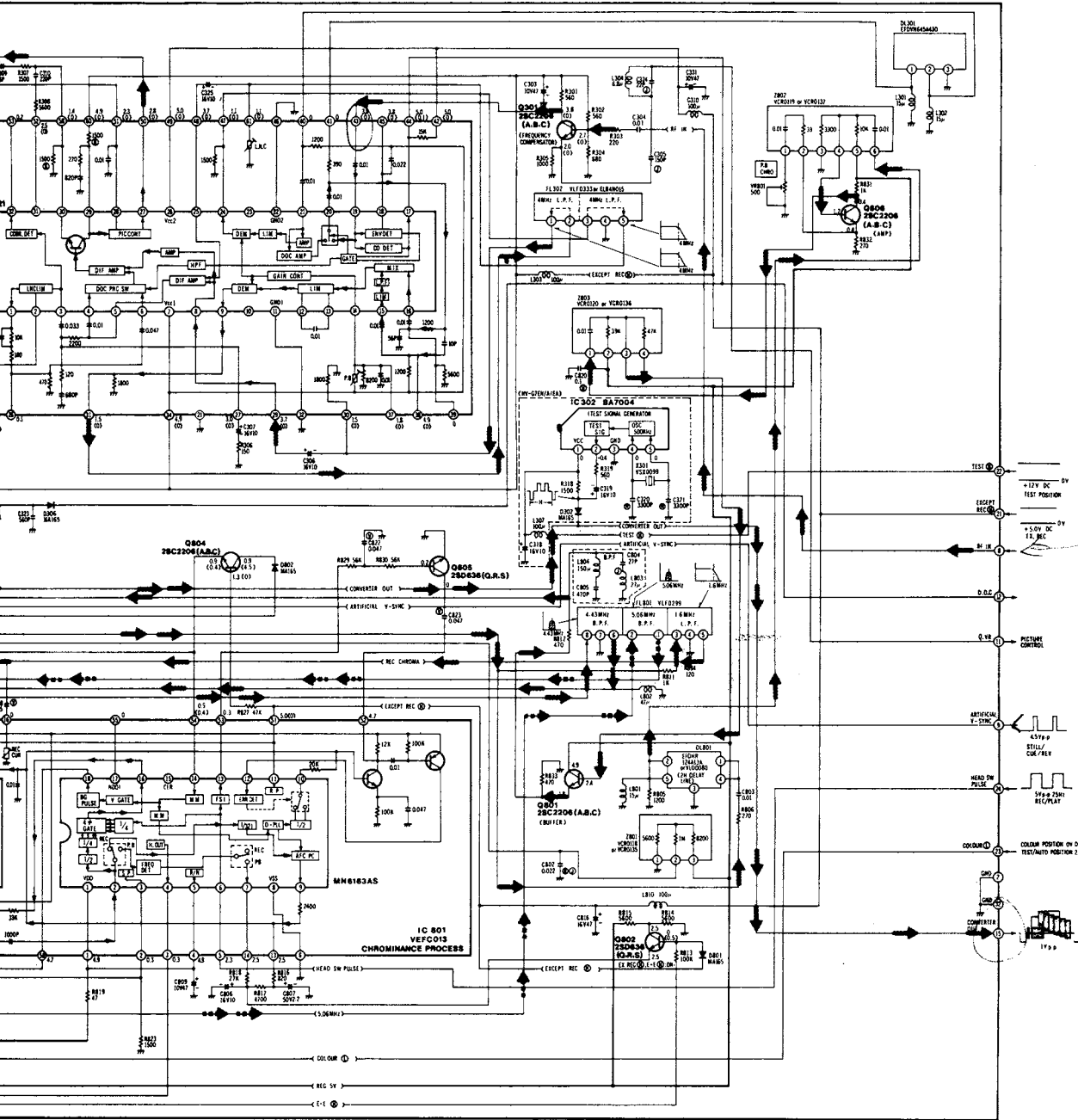

**LUMINANCE & CHROMINANCE PACK SCHEMATIC**

Transistor	
Q301	H-10
Q302	D-2
Q303	F-2
Q801	C-10
Q802	B-11
Q803	B-2
Q804	E-8
Q805	E-9
Q806	G-12

Transistor & Resistor	
QR301	F-2

Integrated Circuit	
IC301	H-8
IC302	F-10
IC801	B-9

Adjustment	
VR801	G-11

ADDRESS INFORMATION

NOTE: DO NOT USE THE PART NUMBER SHOWN ON THIS DRAWING FOR ORDERING THE CORRECT PART NUMBER IS SHOWN IN THE PARTS LIST, AND MAY BE SLIGHTLY DIFFERENT OR AMENDED SINCE THIS DRAWING WAS PREPARED.

NOTE: THE MEASUREMENT MODE OF THE DC VOLTAGE IN THE BRACKETS ( ) ON THIS WITH PAL COLOUR SIGNAL. THE MEASUREMENT MODE OF THE DC VOLTAGE OUT OF THE BRACKETS ON THIS WITH PAL COLOUR SIGNAL.

### 3-16. HEAD AMP PACK SCHEMATIC DIAGRAM

← MAIN SIGNAL PATH IN REC MOD

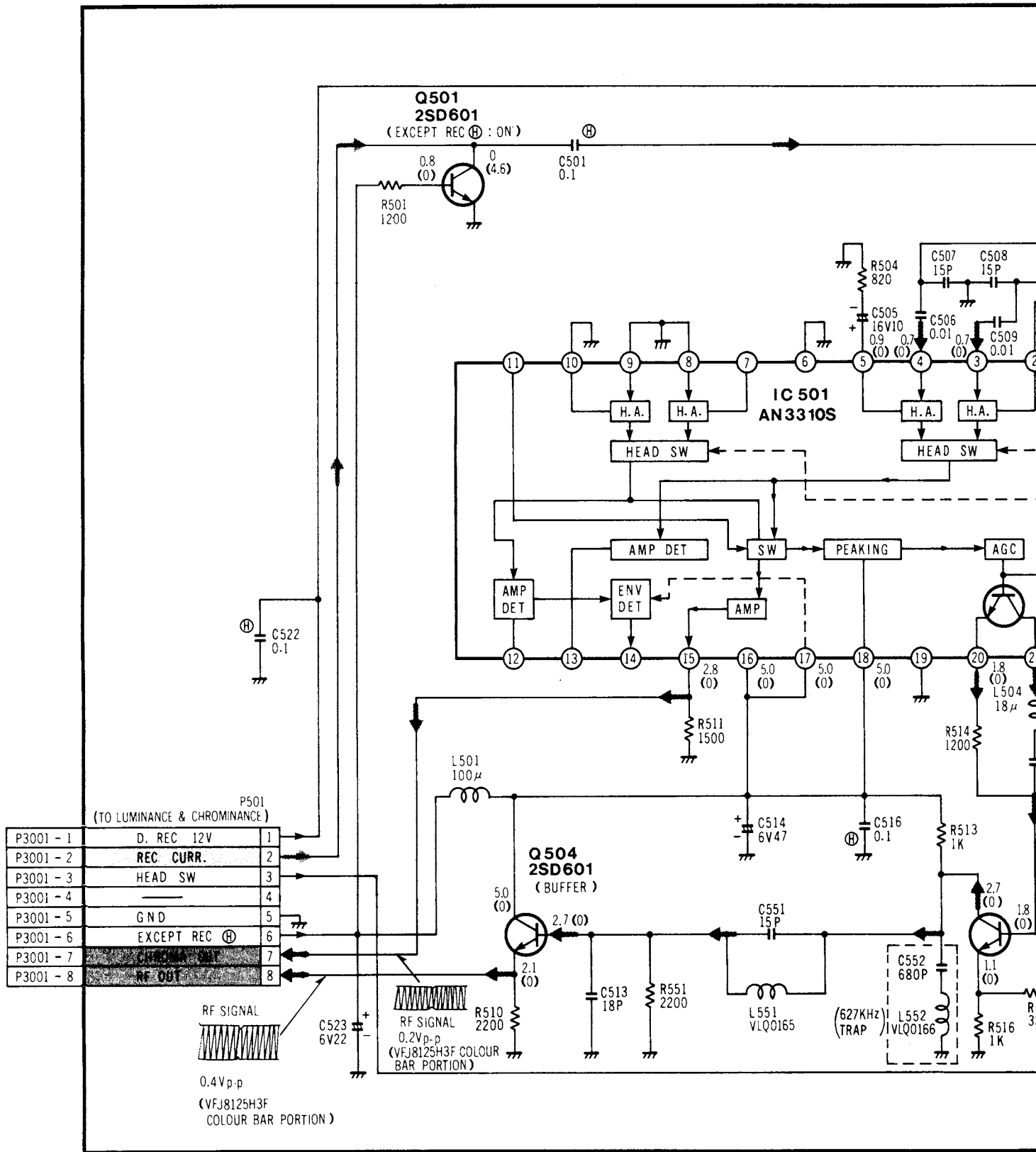

NOTE DO NOT USE THE PART NUMBER SHOWN ON THIS DRAWING FOR ORDERING. THE CORRECT PART NUMBER IS SHOWN IN THE PARTS LIST, AND MAY BE SLIGHTLY DIFFERENT OR AMENDED SINCE THIS DRAWING WAS PREPARED.

NOTE: THE MEASUREMENT MODE OF THE WITH PAL COLOUR SIGNAL. THE MEASUREMENT MODE OF THE WITH PAL COLOUR SIGNAL.

TH IN REC MODE

← MAIN SIGNAL PATH IN PLAYBACK MODE

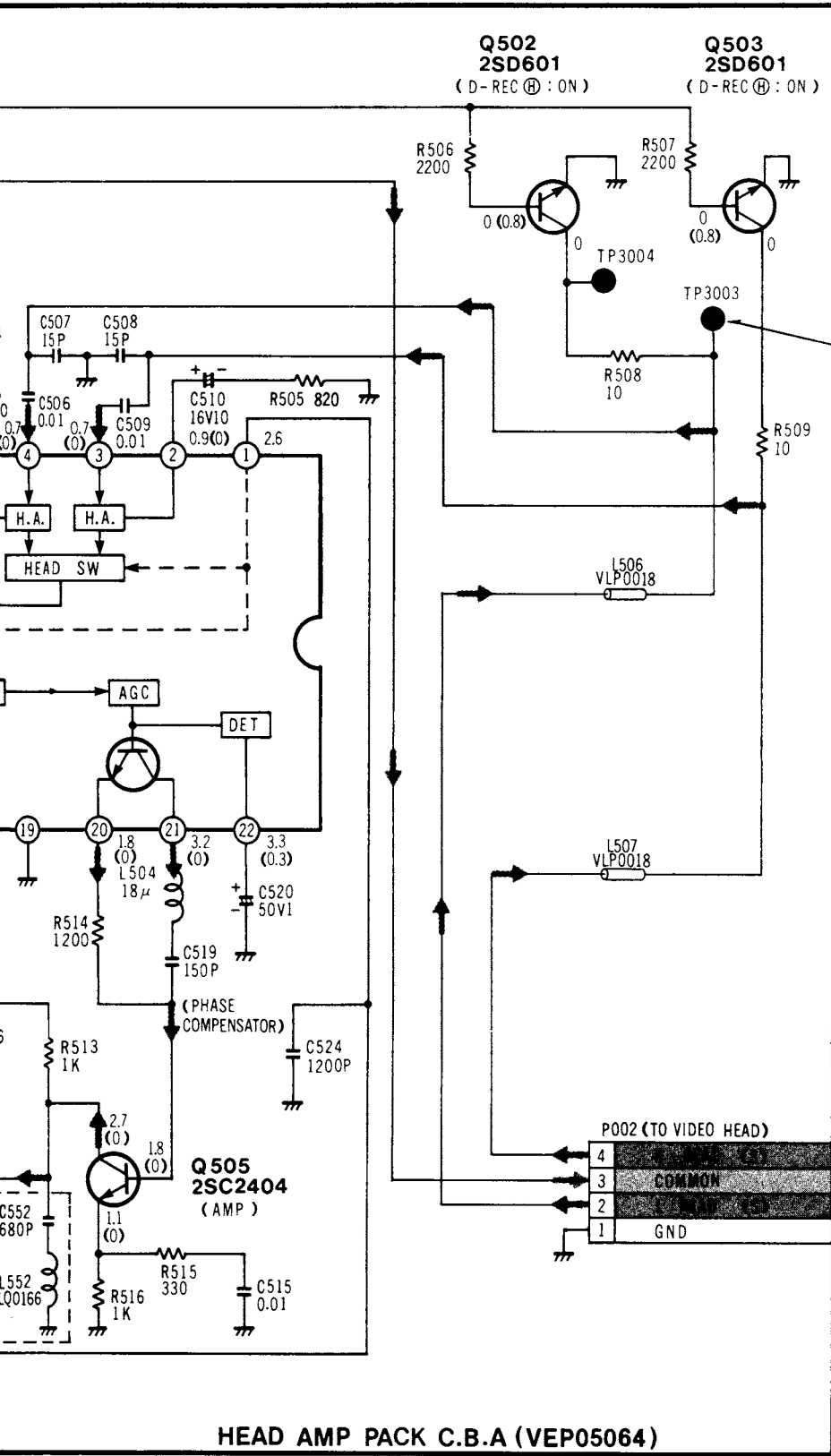

HEAD AMP PACK C.B.A (VEP05064)

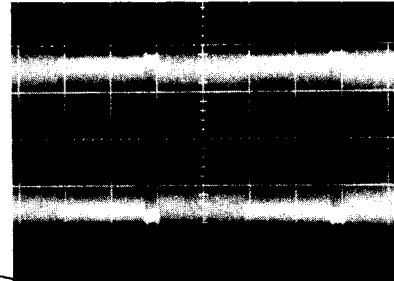

TP3003REC  
50mV/5msec. div. 0.2Vp-p

ICs & TRANSISTORS INFORMATION

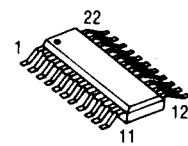

AN3310S

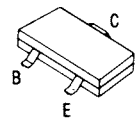

2SD601  
2SC2404

MEASUREMENT MODE OF THE DC VOLTAGE IN THE BRACKETS ( ) ON THIS DIAGRAM IS RECORD MODE  
COLOUR SIGNAL.  
MEASUREMENT MODE OF THE DC VOLTAGE OUT OF THE BRACKETS ON THIS DIAGRAM IS PLAYBACK MODE  
COLOUR SIGNAL.



# AUDIO SCHEMATIC DIAGRAM

← MAIN SIGNAL PATH IN RECORD MODE

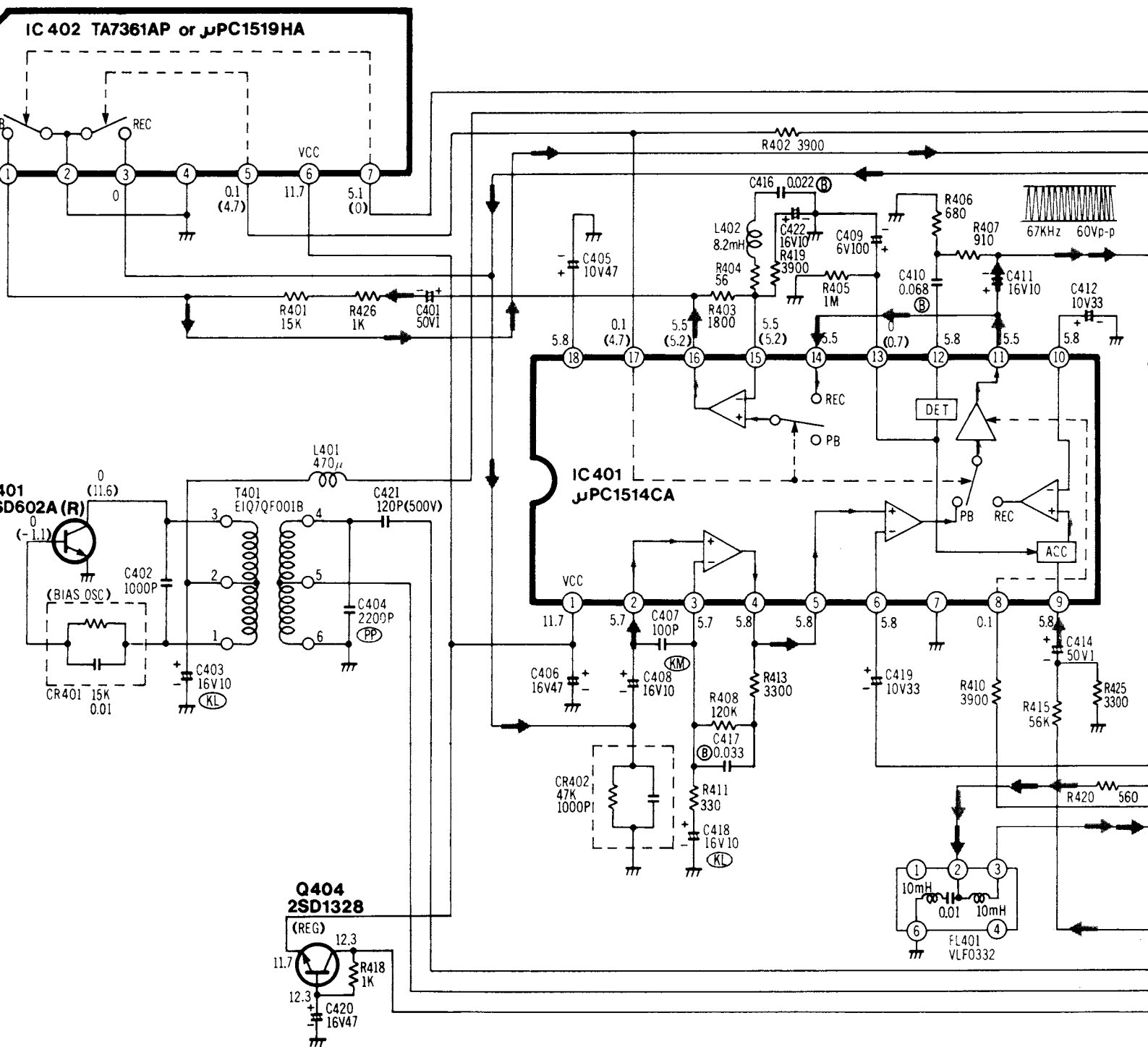

MEASUREMENT MODE OF THE DC VOLTAGE IN THE BRACKETS ( ) ON THIS DIAGRAM IS RECORD MODE.  
 MEASUREMENT MODE OF THE DC VOLTAGE OUT OF THE BRACKETS ON THIS DIAGRAM IS PLAYBACK MODE.

NOTE: DO NOT USE THE PART NUMBER SHOWN ON THIS DRAWING FOR THE CORRECT PART NUMBER IS SHOWN IN THE PARTS LIST, AND SLIGHTLY DIFFERENT OR AMENDED SINCE THIS DRAWING WAS P

← MAIN SIGNAL PATH IN PLAYBACK MODE

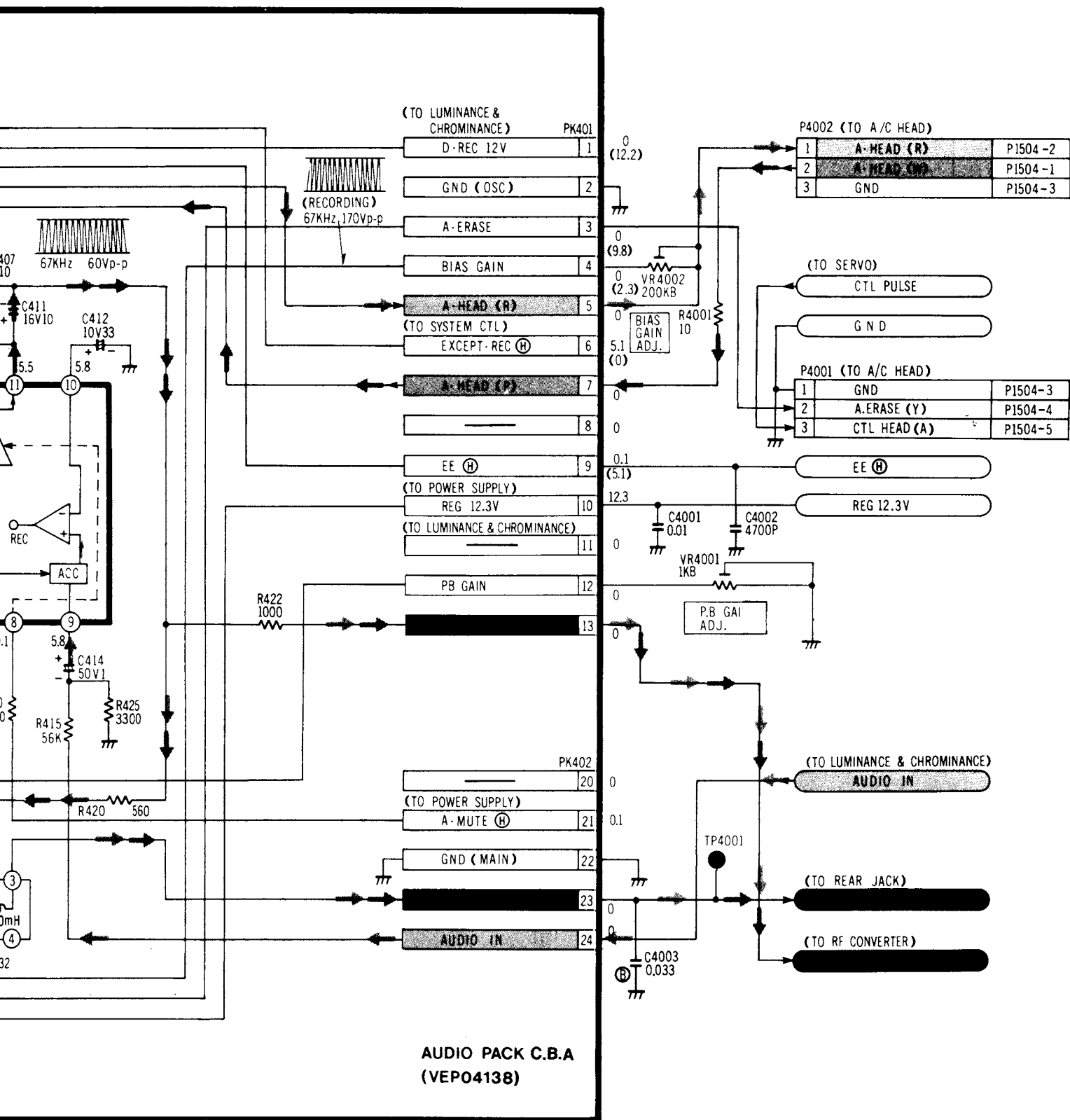

OWN ON THIS DRAWING FOR ORDERING.  
 OWN IN THE PARTS LIST, AND MAY BE  
 SINCE THIS DRAWING WAS PREPARED.



# 3-21. OPERATION, TIMER & CH SELECT SCHEMATIC DIAGRAM

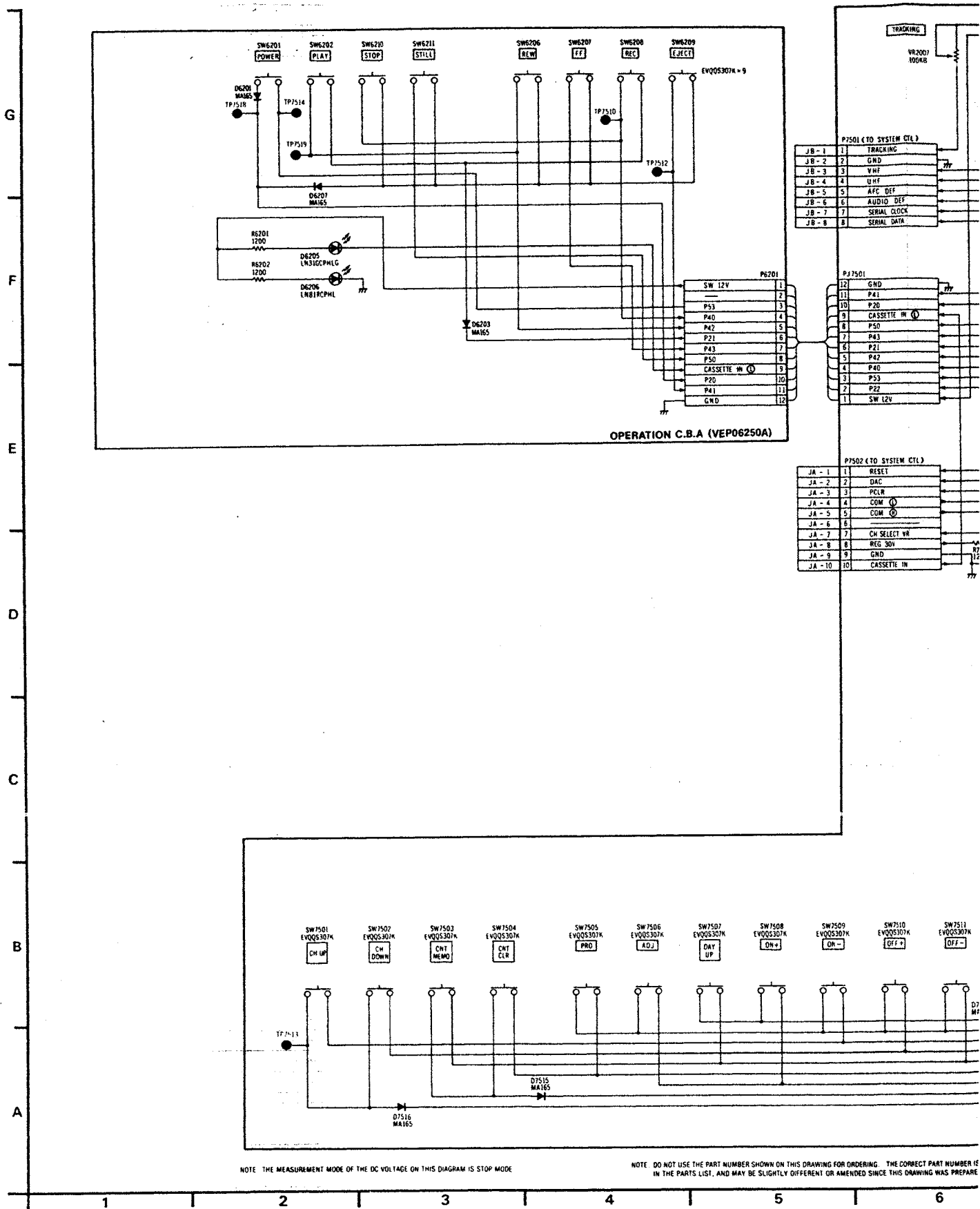

NOTE: THE MEASUREMENT MODE OF THE DC VOLTAGE ON THIS DIAGRAM IS STOP MODE

NOTE: DO NOT USE THE PART NUMBER SHOWN ON THIS DRAWING FOR ORDERING. THE CORRECT PART NUMBER IS IN THE PARTS LIST, AND MAY BE SLIGHTLY DIFFERENT OR AMENDED SINCE THIS DRAWING WAS PREPARED

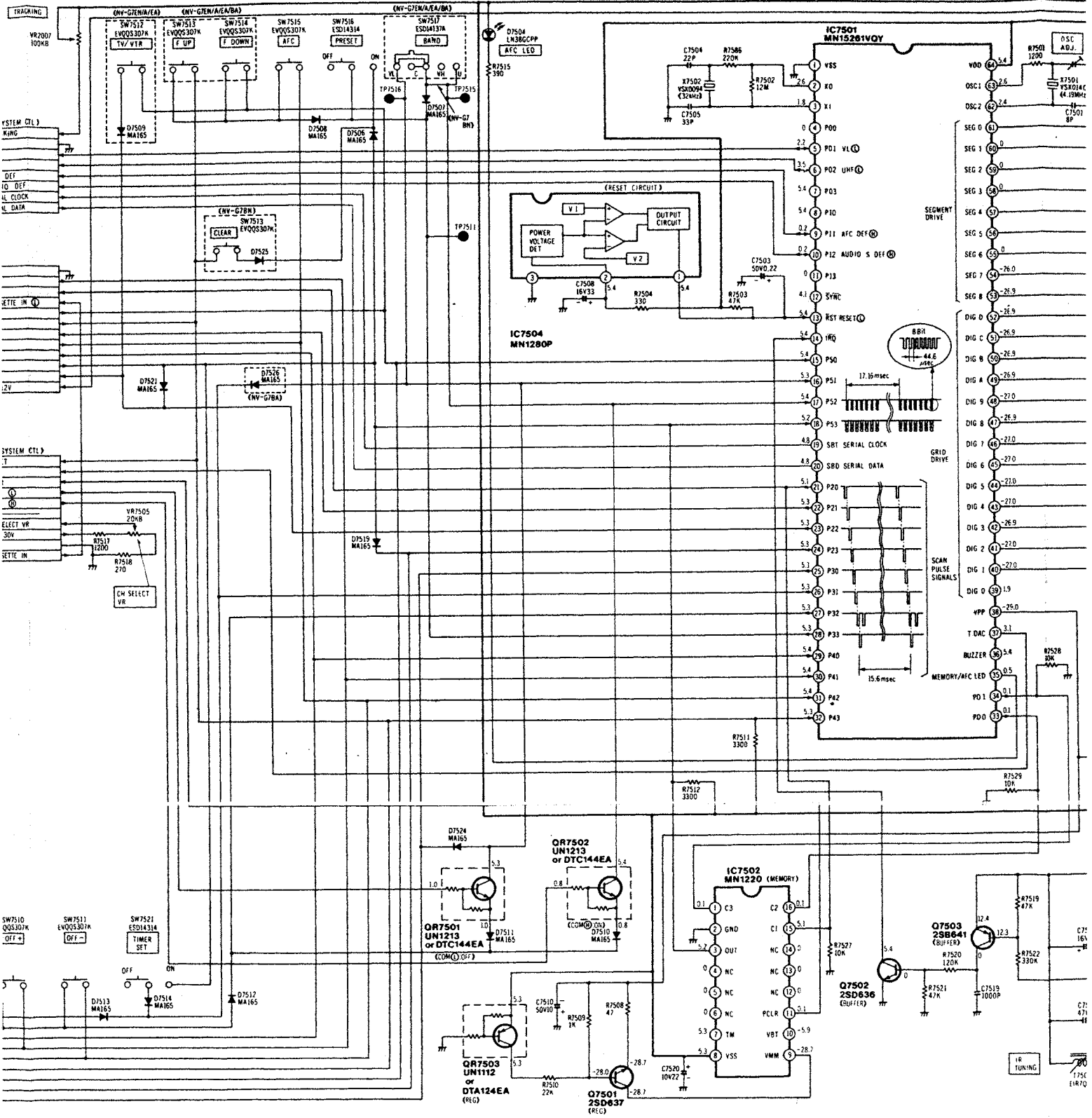

THE CORRECT PART NUMBER IS SHOWN  
 IN THIS DRAWING WAS PREPARED.

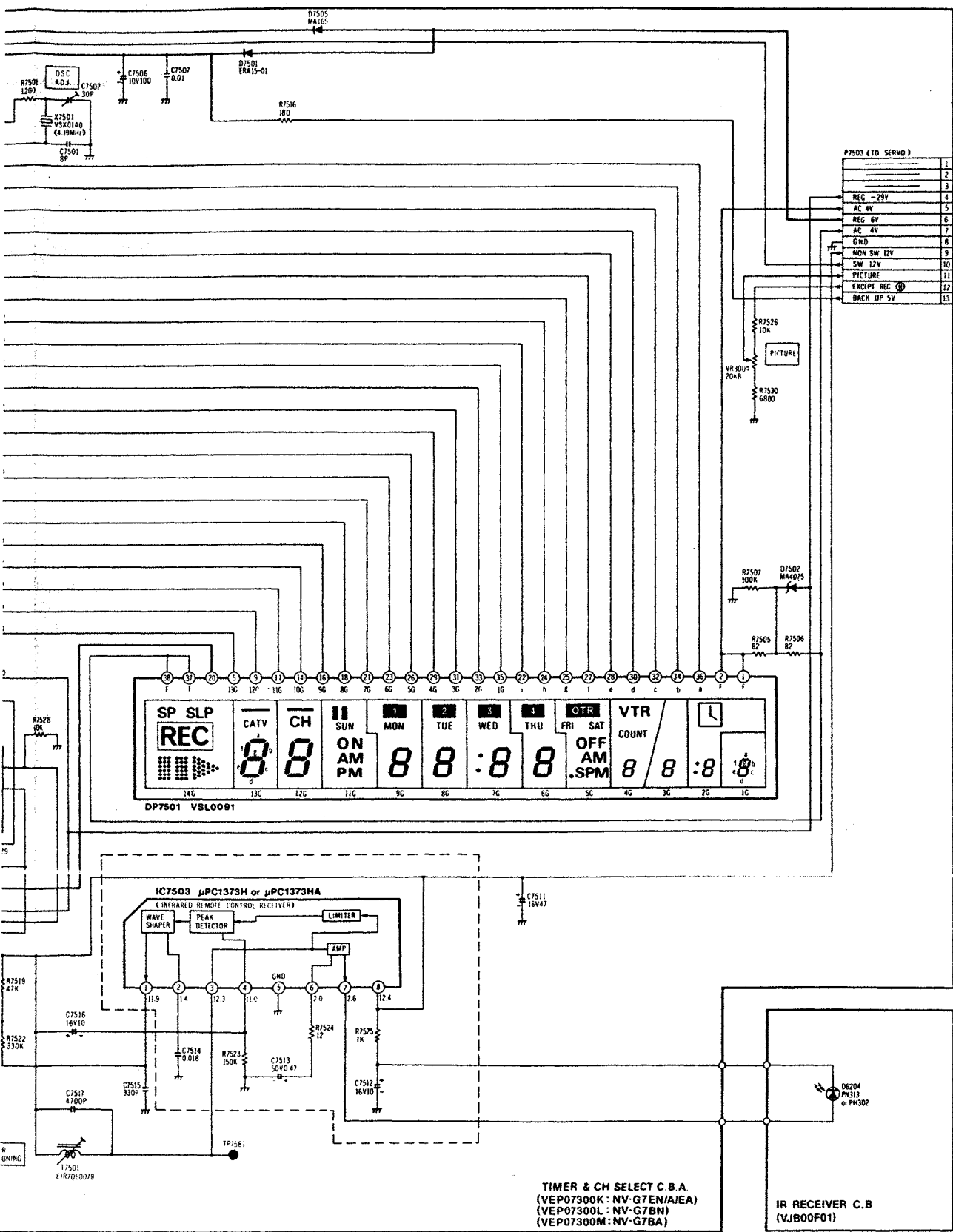

P7503 (10 SERV)

1	---
2	P2002-2
3	P2002-3
4	P2002-4
5	P2002-5
6	P2002-6
7	P2002-7
8	P2002-8
9	P2002-9
10	P2002-10
11	P2002-11
12	P2002-12
13	P2002-13

TIMER & CH SELECT C.B.A.  
 (VEP07300K: NV-G7EN/AIEA)  
 (VEP07300L: NV-G7BN)  
 (VEP07300M: NV-G7BA)

IR RECEIVER C.B.  
 (VJB00F01)

NOTE: THE MEASUREMENT MODE OF THE DC VOLTAGE ON THIS  
 DIAGRAM IN THE FOLLOWING CONDITION:  
 1) CLOCK SWITCH: FLASH CLOCK  
 2) SELECTION TIME: SUN 0:00, CH DISPLAY: 1, VTR COUNT: 0000

### 3-23. TUNER & TV DEMODULATOR SCHEMATIC DIAGRAM (NV-G7EN)

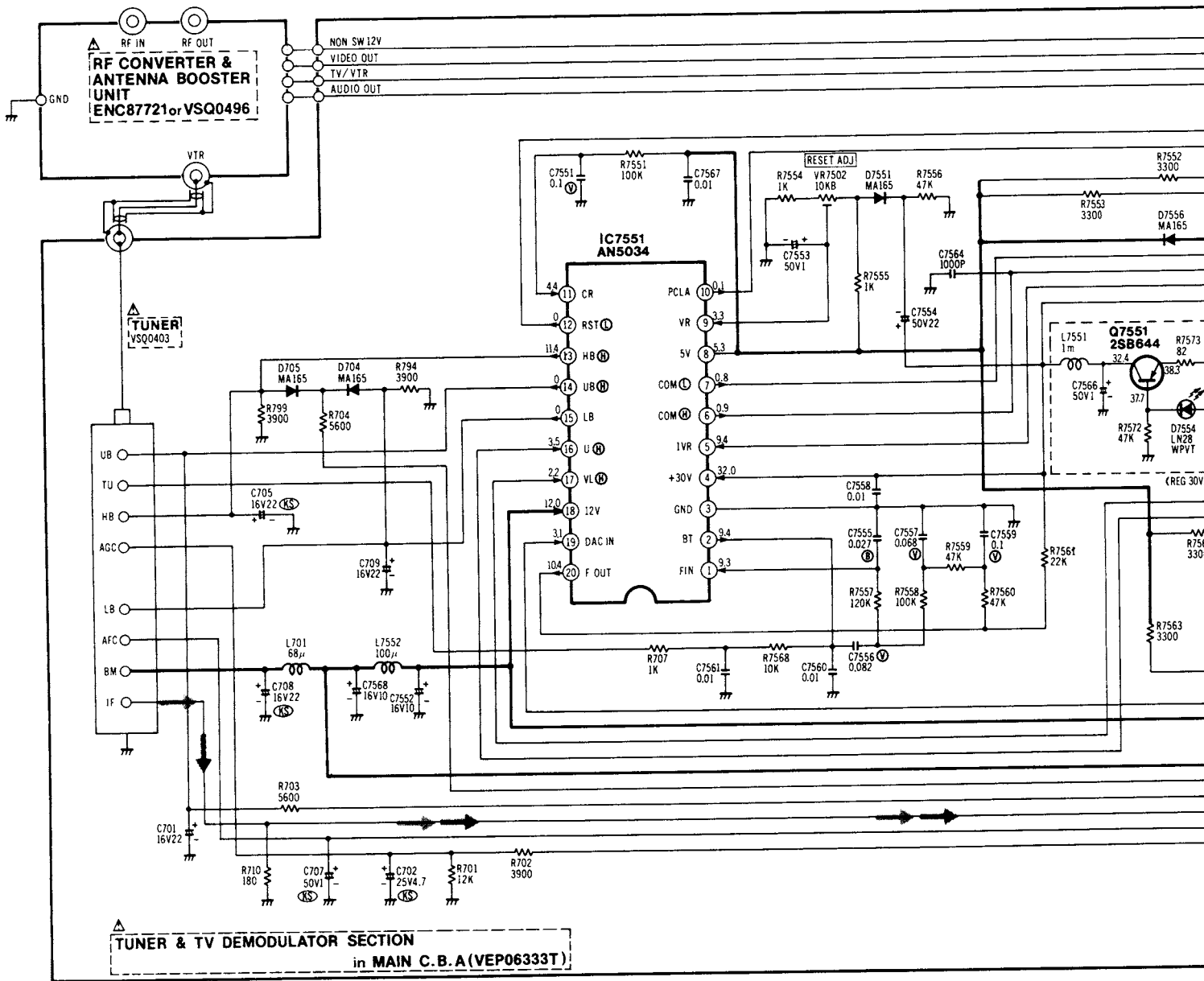



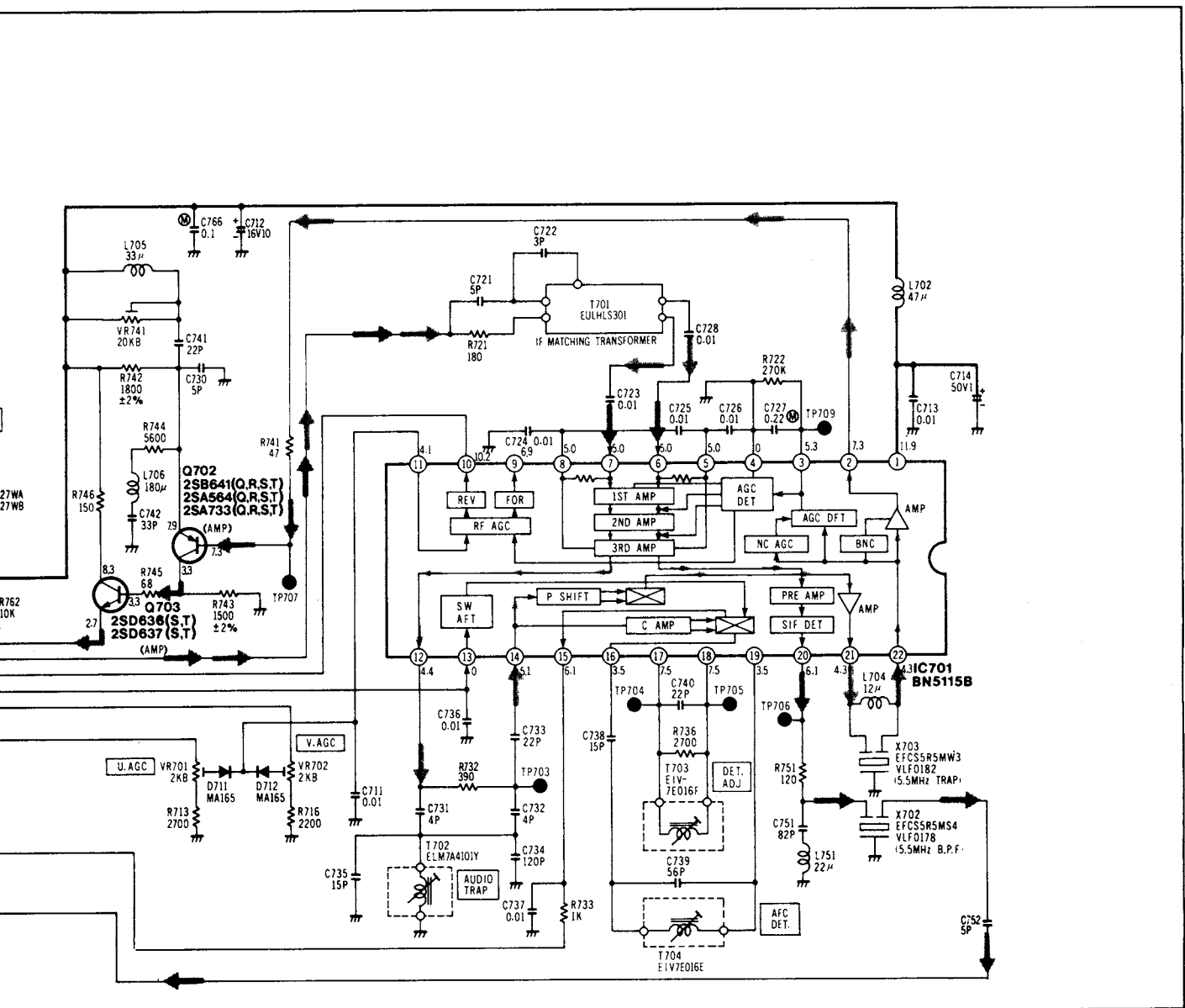

GNAL LOOP

NOTE: THE MEASUREMENT MODE OF THE DC VOLTAGE ON THIS DIAGRAM IS STOP MODE

**IMPORTANT SAFETY NOTICE:** COMPONENTS IDENTIFIED WITH THE MARK  $\Delta$  HAVE THE SPECIAL CHARACTERISTICS FOR SAFETY WHEN REPLACING ANY OF THESE COMPONENTS. USE ONLY THE SAME TYPE

NOTE: DO NOT USE THE PART NUMBER SHOWN ON THIS DRAWING FOR ORDERING. THE CORRECT PART NUMBER IS SHOWN IN THE PARTS LIST, AND MAY BE SLIGHTLY DIFFERENT OR AMENDED SINCE THIS DRAWING WAS PREPARED.

**ICs & TRANSISTORS INFORMATION**

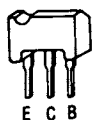

2SD636  
2SB641  
2SB644

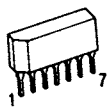

AN5215

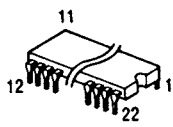

BN5115B

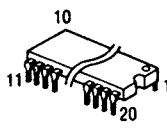

AN5034

### 3-28. TUNER & TV DEMODULATOR SCHEMATIC DIAGRAM (NV-G7A/EA/BA)

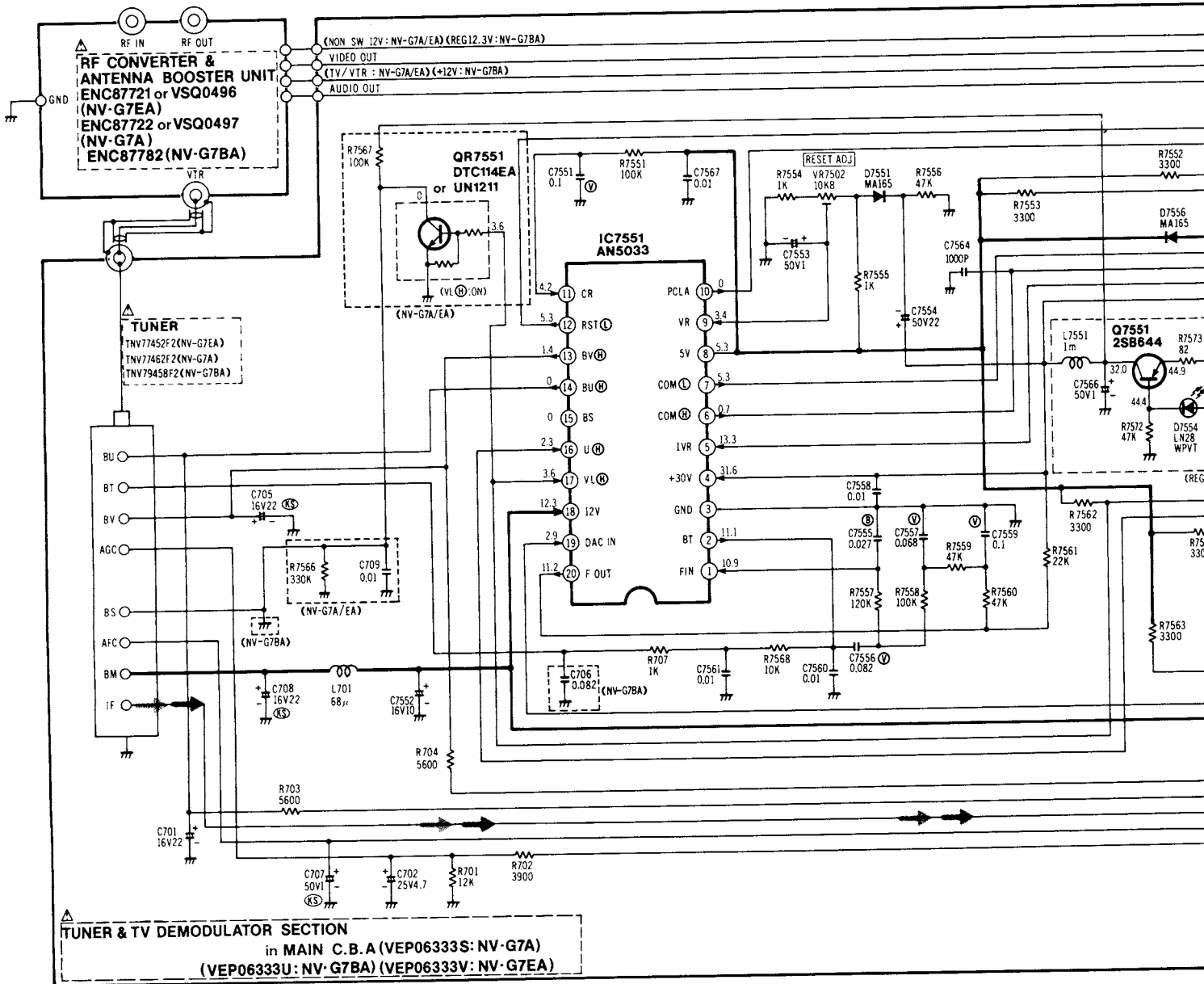

(A/EA/BA)

← VIDEO SIGNAL LOOP

← AUDIO SIGNAL LOOP

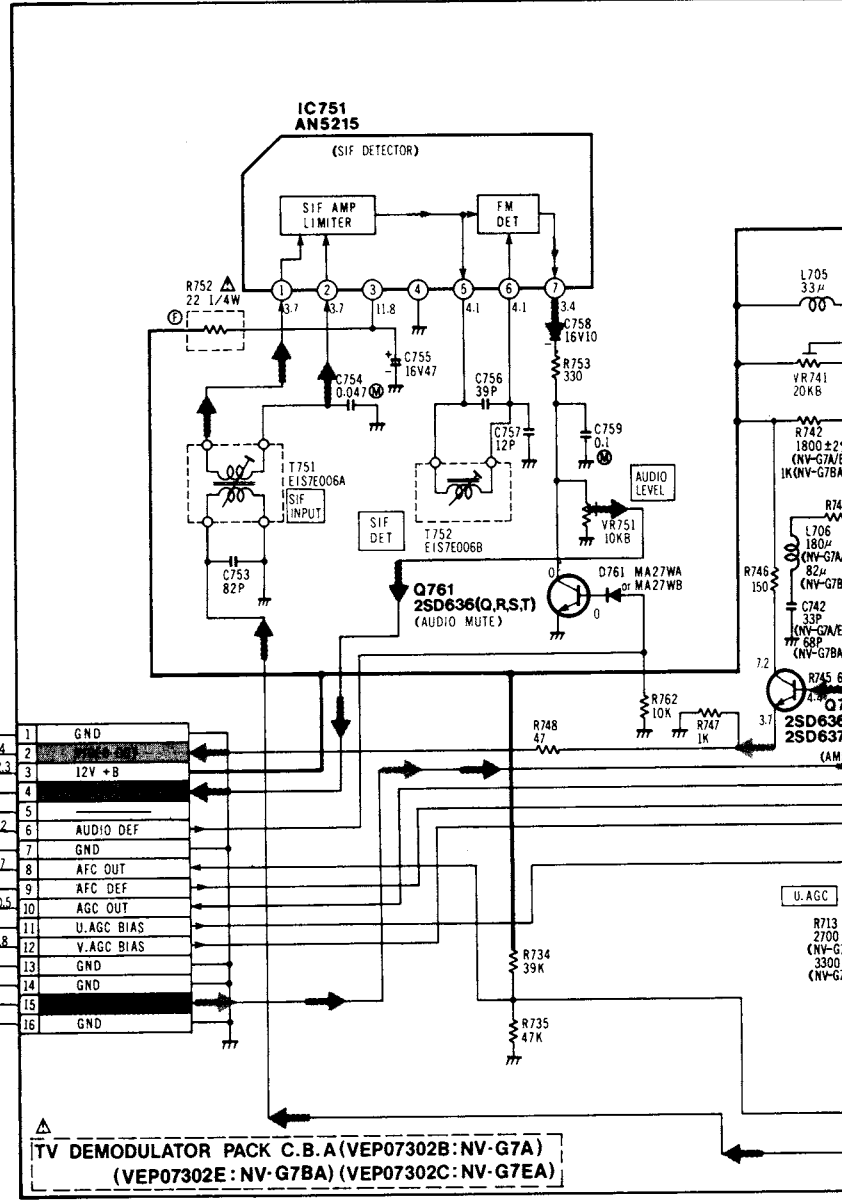
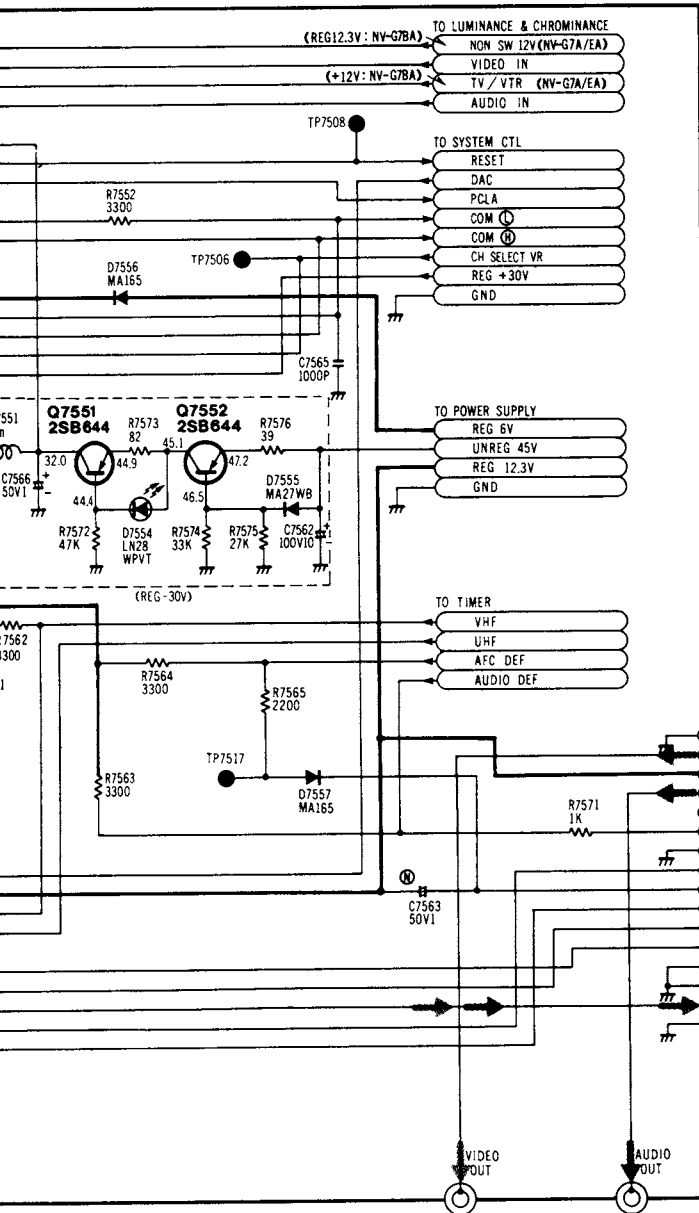

ICs & TRANSISTORS INFORMATION

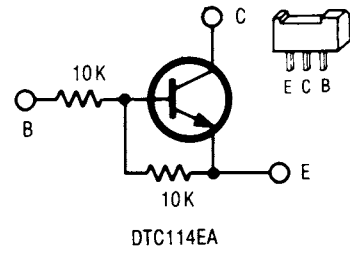
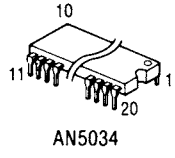
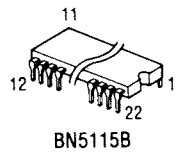
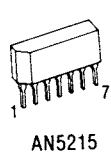
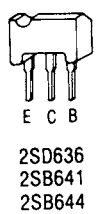



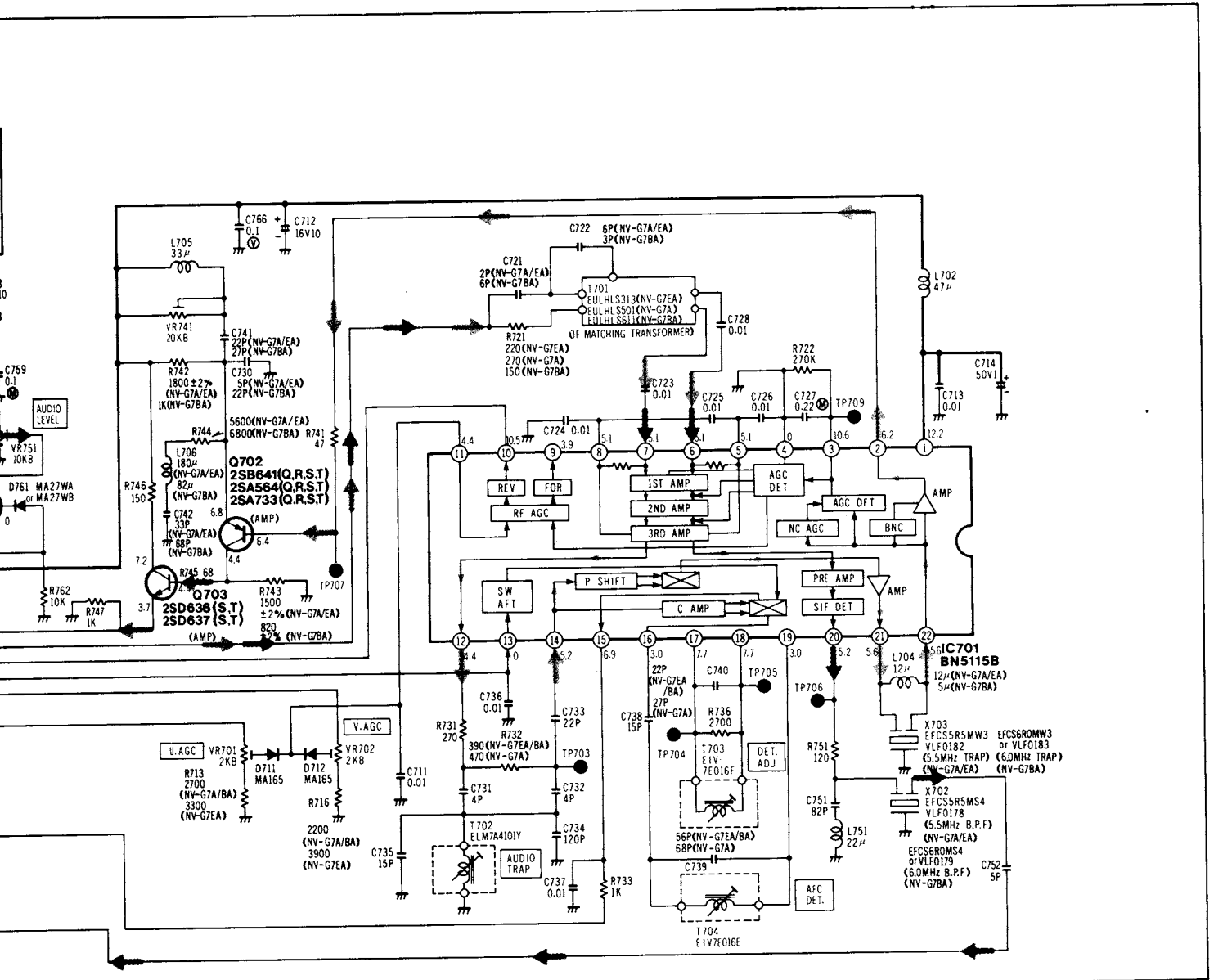

NOTE: DO NOT USE THE PART NUMBER SHOWN ON THIS DRAWING FOR ORDERING. THE CORRECT PART NUMBER IS SHOWN IN THE PARTS LIST, AND MAY BE SLIGHTLY DIFFERENT OR AMENDED SINCE THIS DRAWING WAS PREPARED.

NOTE: THE MEASUREMENT MODE OF THE DC VOLTAGE ON THIS DIAGRAM IS STOP MODE.

**IMPORTANT SAFETY NOTICE:** COMPONENTS IDENTIFIED WITH THE MARK  $\Delta$  HAVE THE SPECIAL CHARACTERISTICS FOR SAFETY WHEN REPLACING ANY OF THESE COMPONENTS. USE ONLY THE SAME TYPE

### 3-29. TUNER & TV DEMODULATOR SCHEMATIC DIAGRAM (NV-G7BN)

← VIDEO SIGNAL LOOP

← AUDIO SIGNAL LOOP

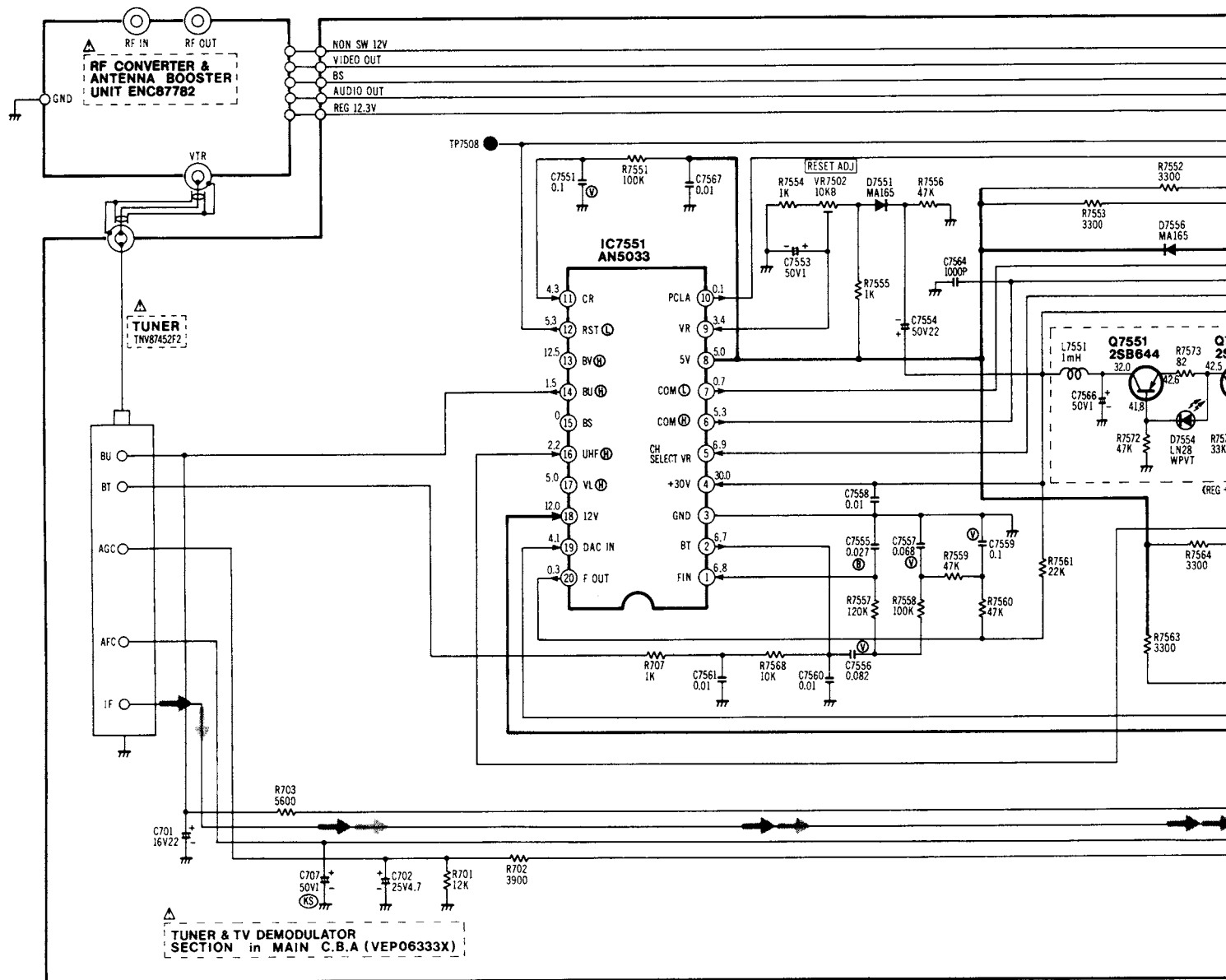

# NV-G7BN)

## SIGNAL LOOP

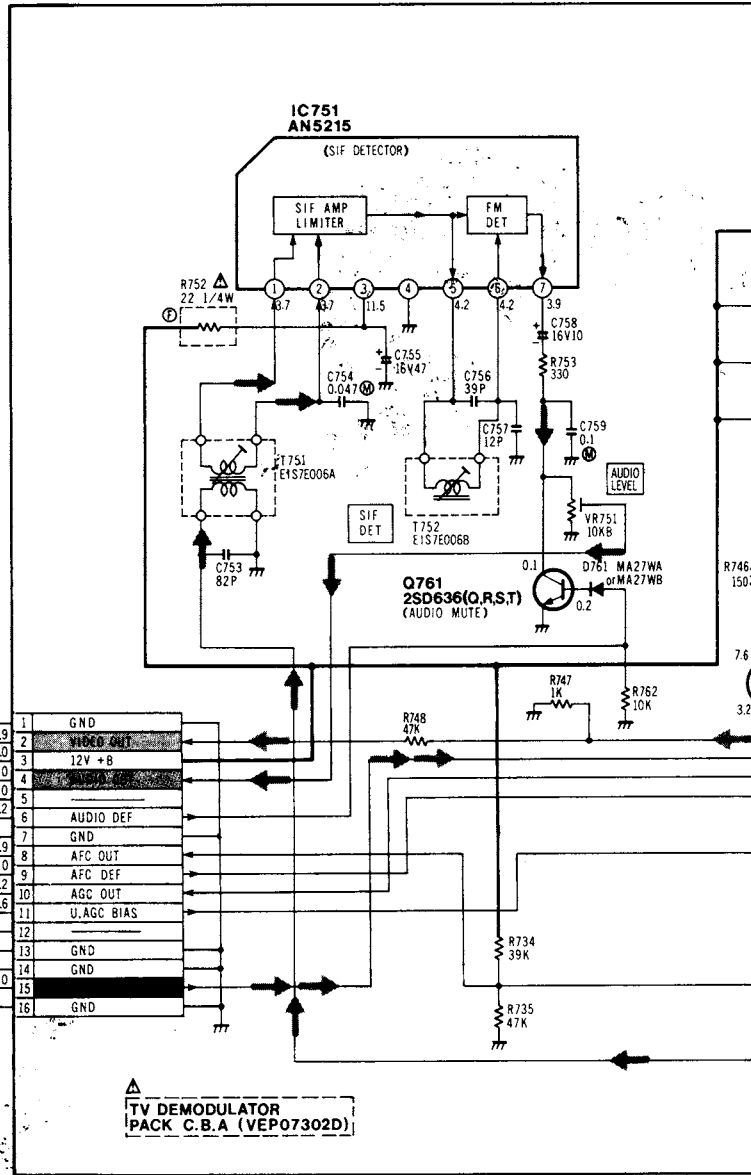
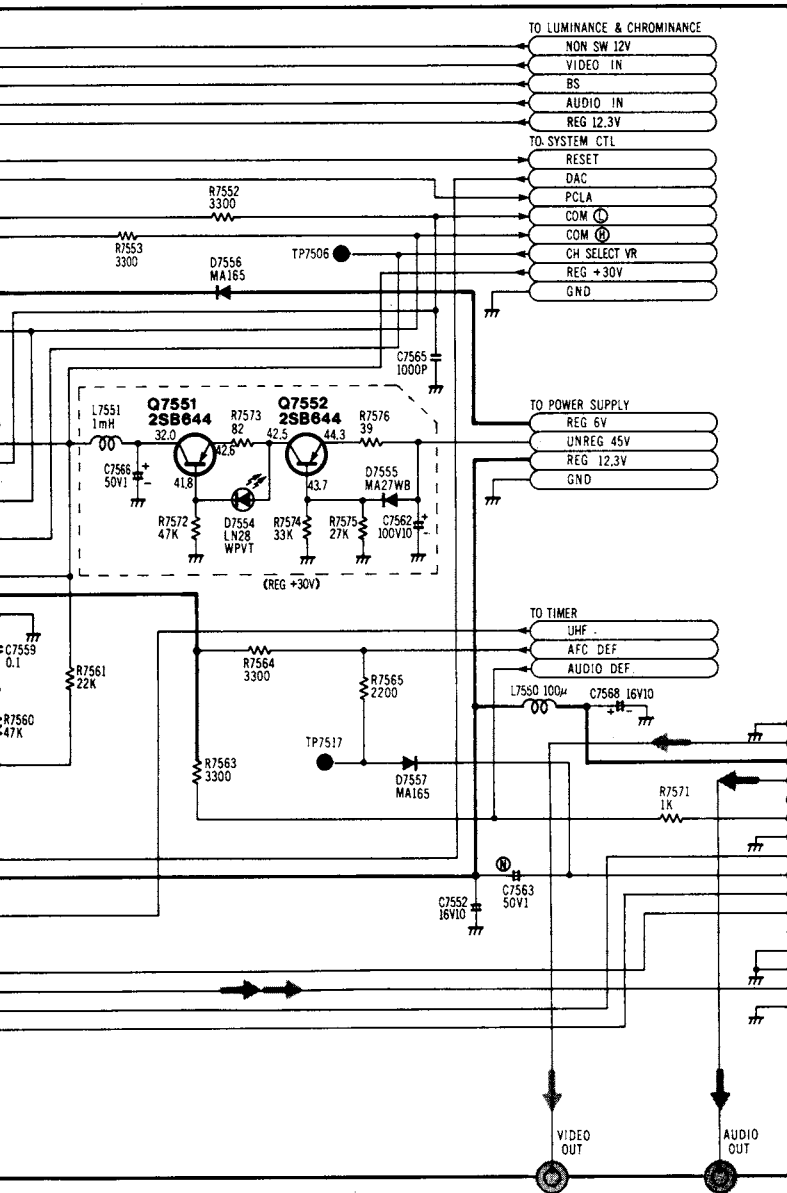

NOTE: DO NOT USE THE PART NUMBER SHOWN IN THE ORIGINAL DRAWING. THE CORRECT PART NUMBER IS SHOWN IN THE DRAWING. THE PART NUMBER IS SLIGHTLY DIFFERENT OR AMENDED.

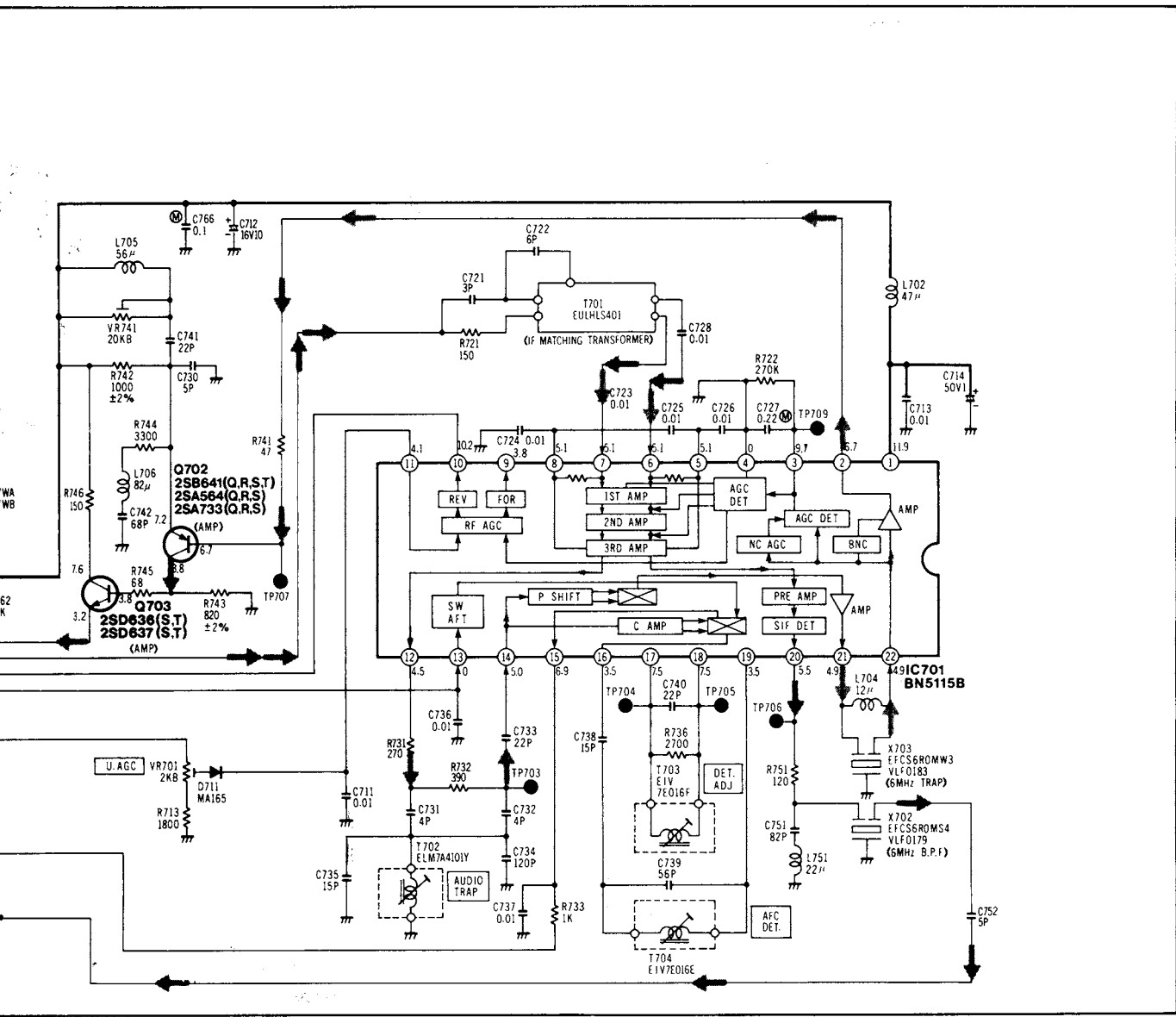

THE PART NUMBER SHOWN ON THIS DRAWING FOR ORDERING. PART NUMBER IS SHOWN IN THE PARTS LIST, AND MAY BE DIFFERENT OR AMENDED SINCE THIS DRAWING WAS PREPARED.

NOTE: THE MEASUREMENT MODE OF THE DC VOLTAGE ON THIS DIAGRAM IS STOP MODE

**IMPORTANT SAFETY NOTICE:** COMPONENTS IDENTIFIED WITH THE MARK  $\Delta$  HAVE THE SPECIAL CHARACTERISTICS FOR SAFETY WHEN REPLACING ANY OF THESE COMPONENTS. USE ONLY THE SAME TYPE

**ICs & TRANSISTORS INFORMATION**



2SD636  
2SB641

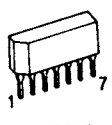

AN5215

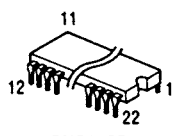

BN5115B

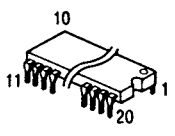

AN5033



**—Unit No. ENC87722: NV-G7A—**

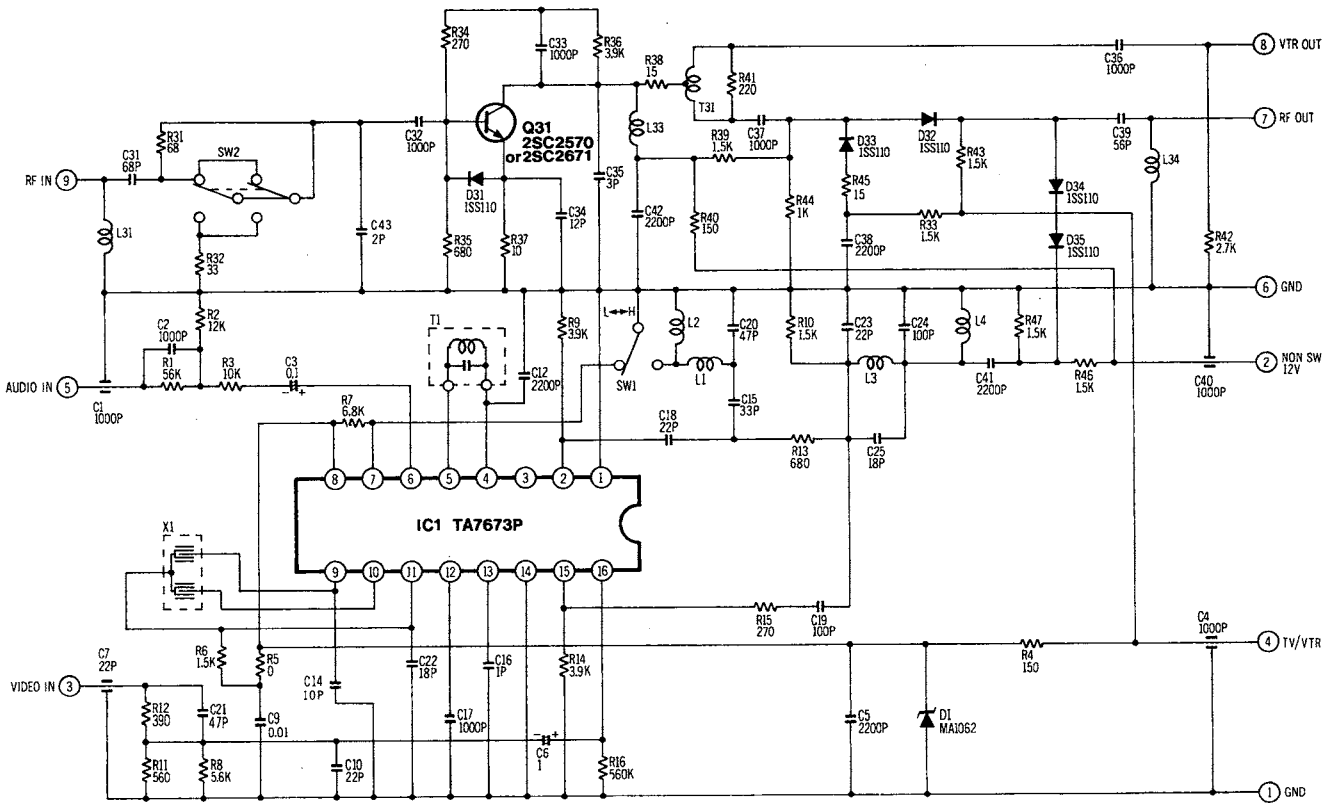

NOTE: DO NOT USE THE PART NUMBER SHOWN ON THIS DRAWING FOR ORDERING. THE CORRECT PART NUMBER IS SHOWN IN THE PARTS LIST, AND MAY BE SLIGHTLY DIFFERENT OR AMENDED SINCE THIS DRAWING WAS PREPARED.

**—Unit No. ENC87722: NV-G7A—**

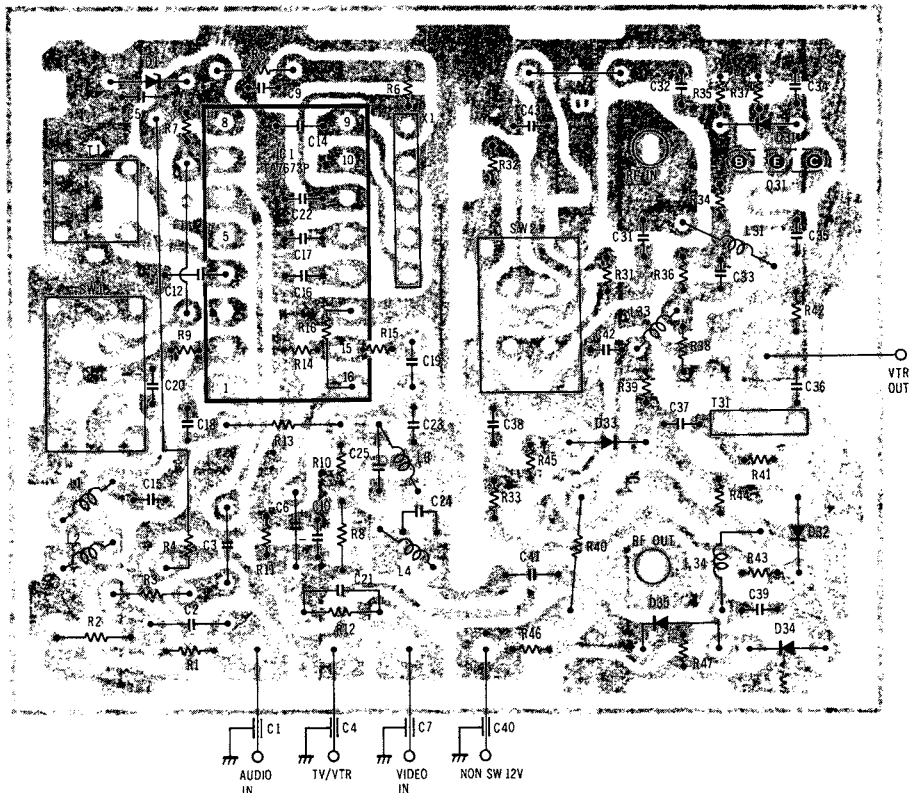

**-Unit No. VSQ0497: NV-G7A-**

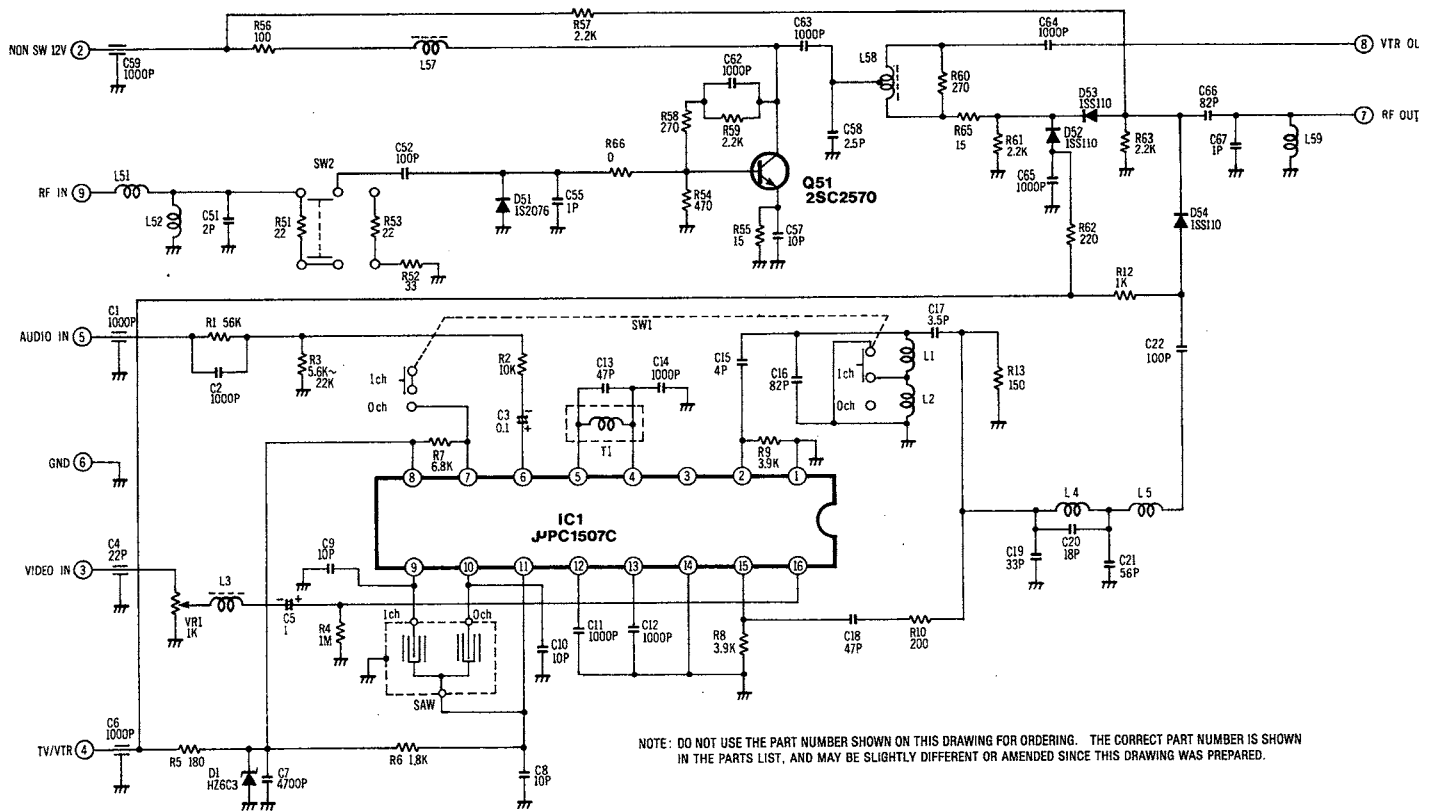

**-Unit No. VSQ0497: NV-G7A-**

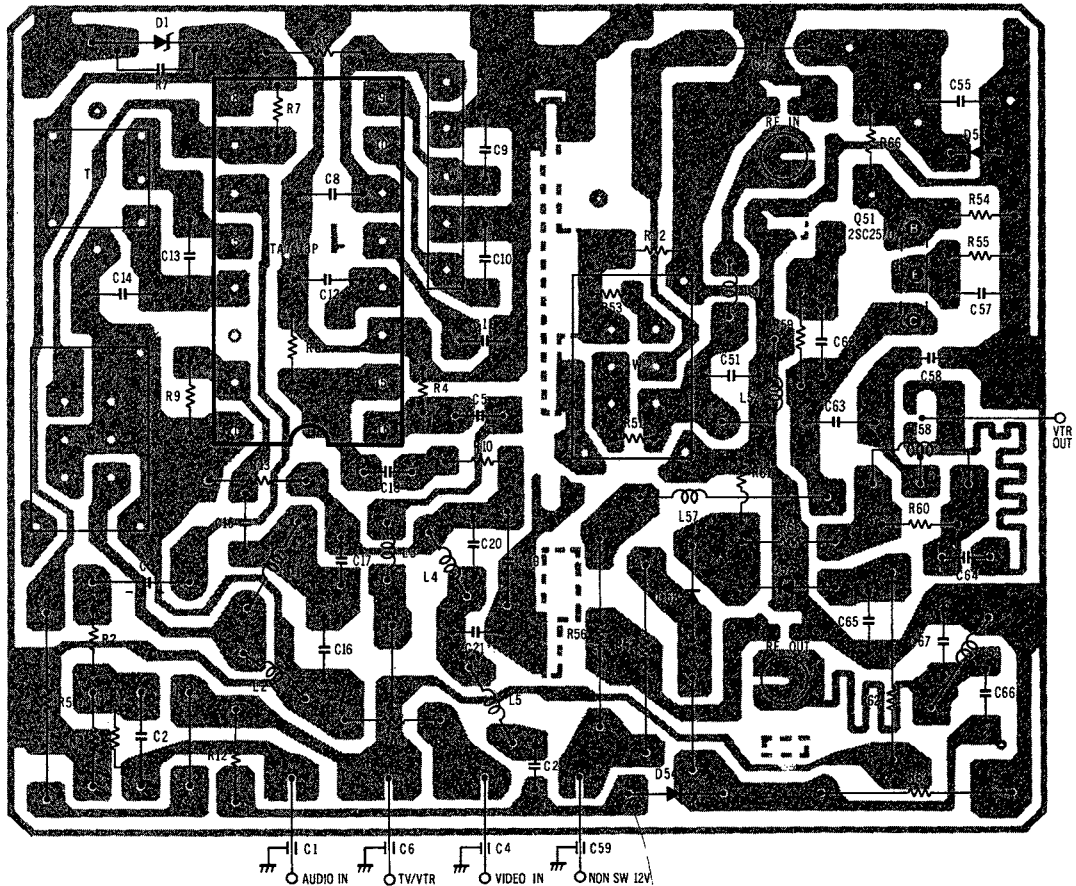

**—Unit No. ENC87782: NV-G7BN/BA—**

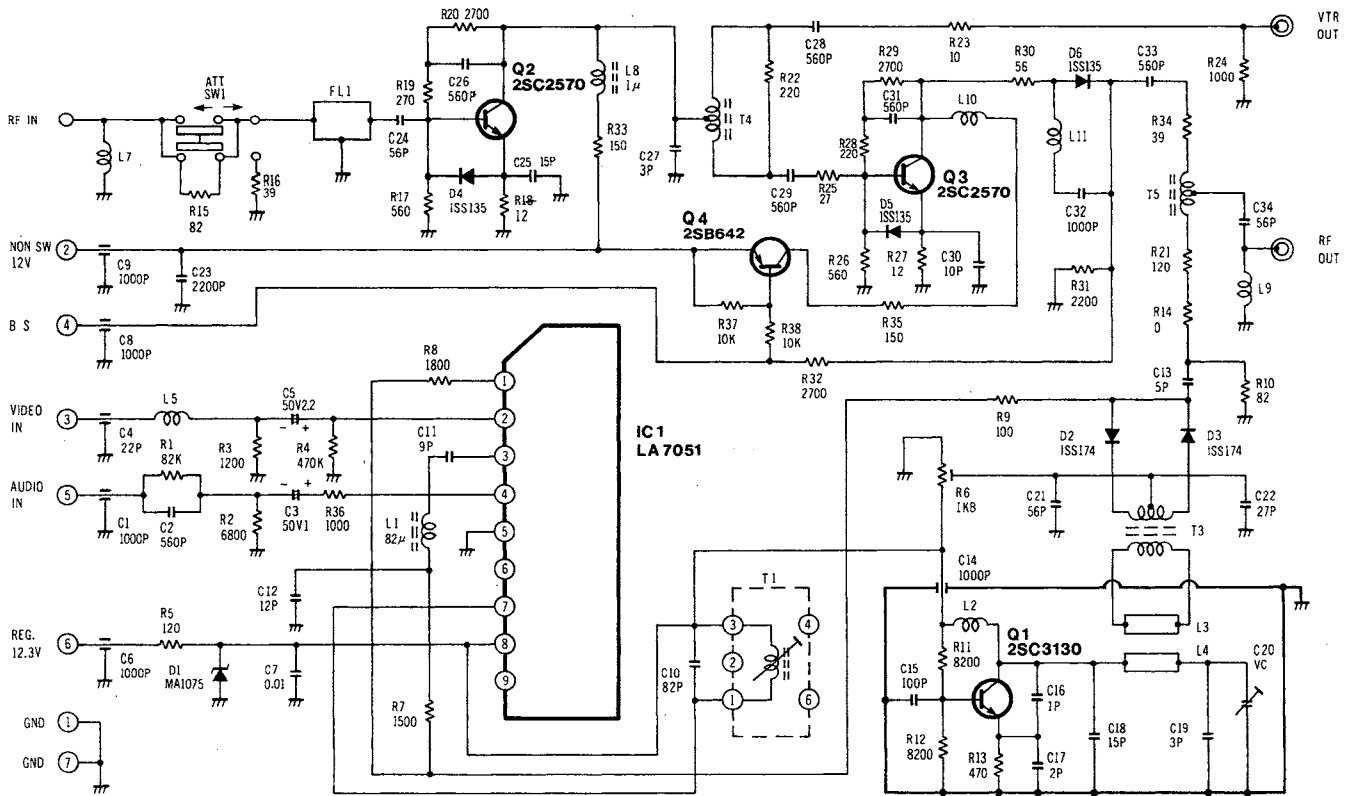

NOTE: DO NOT USE THE PART NUMBER SHOWN ON THIS DRAWING FOR ORDERING. THE CORRECT PART NUMBER IS SHOWN IN THE PARTS LIST, AND MAY BE SLIGHTLY DIFFERENT OR AMENDED SINCE THIS DRAWING WAS PREPARED.

**—Unit No. ENC87782: NV-G7BN/BA—**

