

NOTE: ALL VALUES ARE FOR REFERENCE ONLY. SEE BOM FOR ACTUAL VALUES AND POPULATIONS.

THERE ARE 184 TEST PADS.  
 NET LABEL WITH N/XN (E.G. 2/C4) INDICATE  
 CROSS-REF SHEET NUMBER/COORDINATES  
 COMPONENTS IN DOTTED BOX MAY BE  
 DEPOPULATED/CHANGED IN SOME VERSIONS.  
 USE BOM TO VERIFY VALUE.

| REV | ECO | DESCRIPTION | DWN | CHK | APVL | DATE       |
|-----|-----|-------------|-----|-----|------|------------|
| 05  |     |             |     |     |      | 07/23/2002 |
| 04  |     |             |     |     |      | 07/23/2002 |
| 03  |     |             |     |     |      | 07/23/2002 |
| 02  |     |             |     |     |      | 07/23/2002 |

|  |                                      |  |  |
|--|--------------------------------------|--|--|
| DRAWN: Clare Lee<br>CHECKED: Chih Shang Chiang<br>ENGINEER: Chih Shang Chiang<br>ENGR.MGR.:<br>QUALITY:<br>PRODUCTION: | DATE: 07/23/2002<br>DATE: 07/23/2002 |  | AMERICAN POWER<br>CONVERSION<br><b>SCHEMATIC</b><br>TITLE: ALI_SHAN<br>MODEL#: OS-640-0259<br>FILE NAME: 640-0259_REV05<br>SHEET: 1 OF 4 |
|--|--------------------------------------|--|--|



2 WIRE 1 LINE PHONE/MODEM PROTECTION

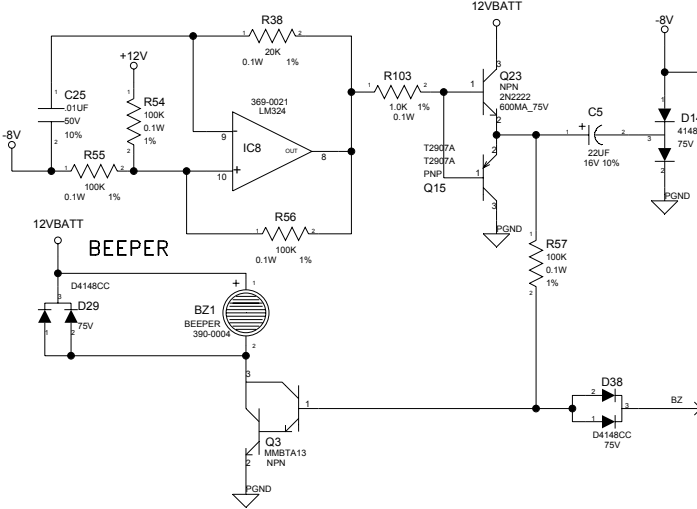
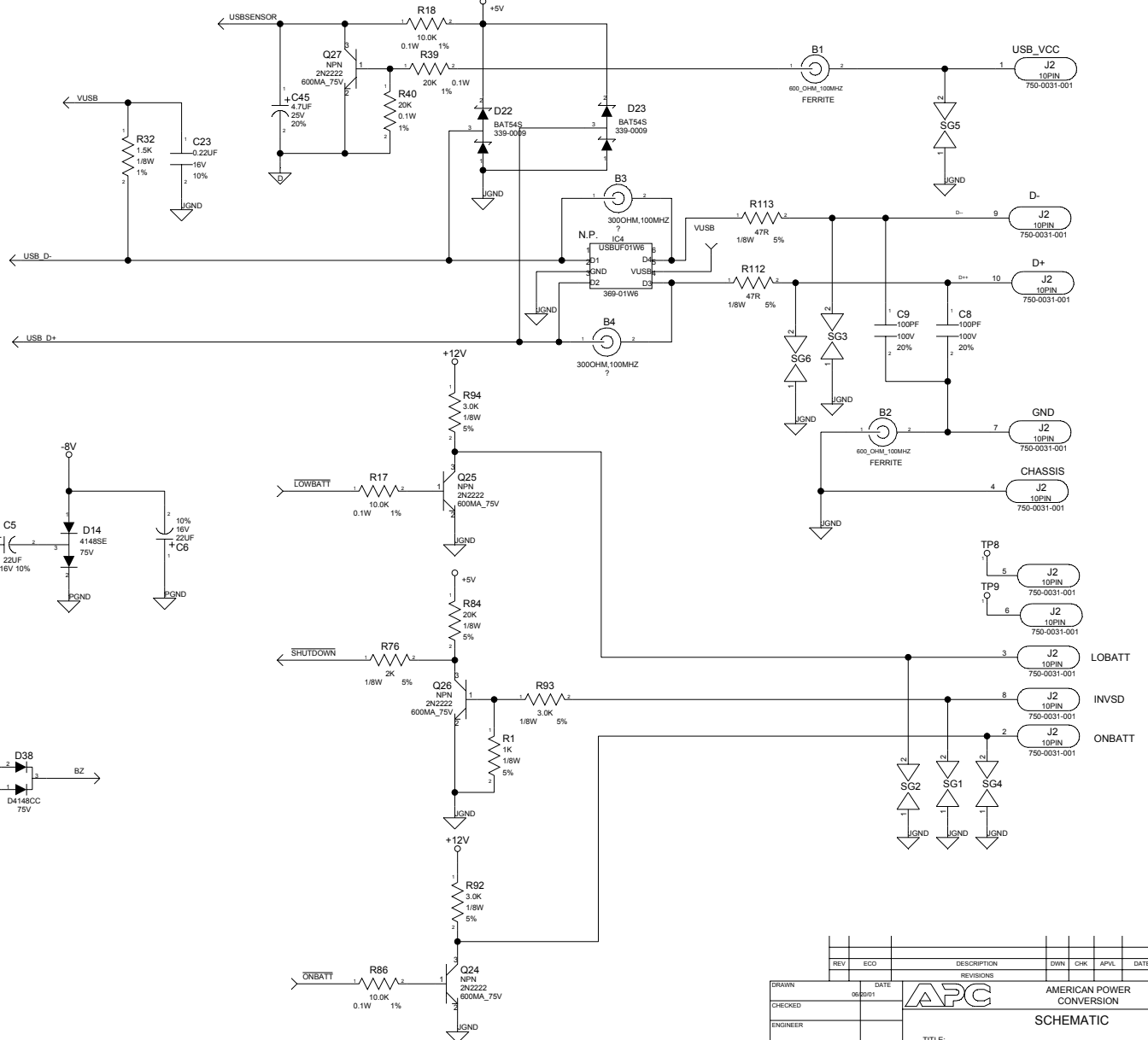
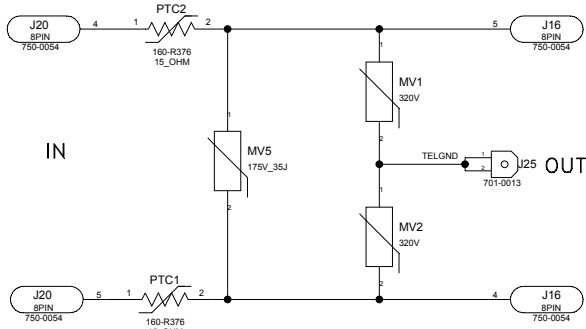

TOOLING HOLES/DECALS

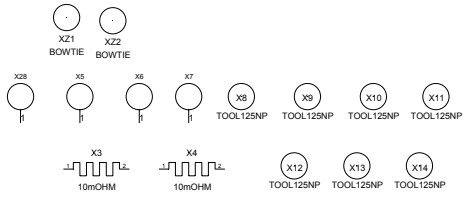

Net Label with N/XN (e.g. 2/C4) indicate Components in dotted box may be depopulated/changed in some versions. Use BOM to verify value.

| REV | ECO | DATE     | DESCRIPTION | DWN | CHK | APVL | DATE |
|-----|-----|----------|-------------|-----|-----|------|------|
|     |     | 06/20/01 |             |     |     |      |      |

|            |      |     |     |   |     |     |      |      |
|------------|------|-----|-----|---|-----|-----|------|------|
| DRAWN      | DATE | REV | ECO | DESCRIPTION <td>DWN</td> <td>CHK</td> <td>APVL</td> <td>DATE</td> | DWN | CHK | APVL | DATE |
| CHECKED    |      |     |     |   |     |     |      |      |
| ENGINEER   |      |     |     |   |     |     |      |      |
| ENGL MGR   |      |     |     |   |     |     |      |      |
| QUALITY    |      |     |     |   |     |     |      |      |
| PRODUCTION |      |     |     |   |     |     |      |      |

|            |  |                           |  |
|------------|--|---------------------------|--|
| TITLE:     |  | AMERICAN POWER CONVERSION |  |
| MODEL#:    |  | SCHEMATIC                 |  |
| SIZE:      |  | D                         |  |
| REV:       |  | 05                        |  |
| SCALE:     |  | NONE                      |  |
| FILE NAME: |  | 640-0259_REV05            |  |
| SHEET:     |  | 3 OF 4                    |  |

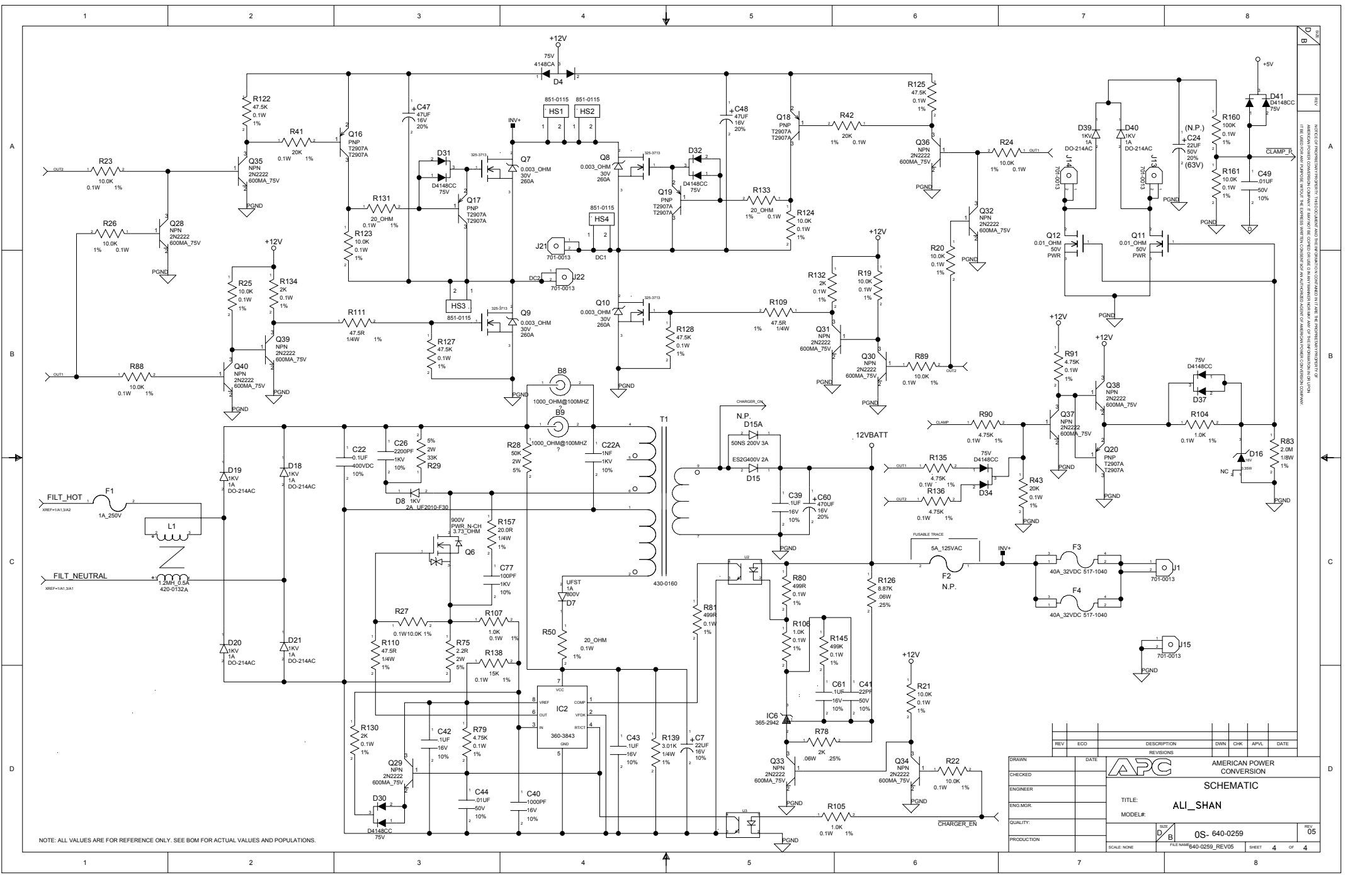

NOTE: ALL VALUES ARE FOR REFERENCE ONLY. SEE BOM FOR ACTUAL VALUES AND POPULATIONS.

| REV | ECO | DESCRIPTION | DWN | CHK | APVL | DATE |
|-----|-----|-------------|-----|-----|------|------|
|     |     |             |     |     |      |      |

|            |  |   |              |
|------------|--|---|--------------|
| DRAWN      |  | DATE  |              |
| CHECKED    |  |  |              |
| ENGINEER   |  | AMERICAN POWER CONVERSION   |              |
| ENG. MGR.  |  | SCHEMATIC   |              |
| QUALITY    |  | TITLE: ALI_SHAN   |              |
| PRODUCTION |  | MODEL#: OS-640-0259   |              |
|            |  | SCALE NONE  | REV 05       |
|            |  | FILE NAME: 640-0259_REV05   | SHEET 4 OF 4 |