



SPECIFICATIONS FOR LCD MODULE

CUSTOMER	STD
MODEL	WM-F4823V4-7FLWa VER. 2
CUSTOMER APPROVED	

APPROVED BY	CHECKED BY	ORGANIZED BY
<p>LCM 產品部 2008/7/25 王天男</p>	<p>LCM 產品部 2008/7/25 林永常</p>	<p>LCM 產品部 2008/7/25 黃文義</p>

APPROVAL FOR SPECIFICATIONS ONLY

APPROVAL FOR SPECIFICATIONS AND SAMPLE (18070566)

10 , Jianguo Rd., Tanzih Township, Taichung County 427, TAIWAN R.O.C.

TEL:886-4-25318899,FAX:886-4-25310868

(1) Electronic Units	4
1.1 Absolute Maximum Ratings	4
1.2 Electrical Characteristics	4
1.3 Interface Pin Function	5
1.4 Power Supply for LCD Module	7
1.5 Block Diagram with Display RAM Address	8
1.6 Timing Characteristic.....	10
1.7 Power ON/OFF SEQUENCE	13
(2) Electro-optical Units	14
2.1 Electro-optical Characteristics	14
2.2 Optical Definitions	15
(3) Mechanical Units	16
3.1 Mechanical Diagram	16
3.2 Back-light Specification	17
3.3 Packing Method	18
(4) Quality Units	19
4.1 Specification of Quality Assurance	19
4.2 Standard Specification for Reliability	22
4.3 Precautions in Use of LCM.....	24
(5) Substance Management Units	25
5.1 Product Substances Management Documentation.....	25

(1) Electronic Units

1.1 Absolute Maximum Ratings

ITEM	SYMBOL	MIN.	TYP.	MAX.	UNIT
OPERATING TEMPERATURE	T_{OP}	-20	-	+70	
STORAGE TEMPERATURE	T_{ST}	-30	-	+80	
INPUT VOLTAGE	V_{IN}	-0.3		$V_{DDIO}+0.3$	V
CHARGE PUMP POWER SUPPLY	PVDD	-0.3	-	+7.0	V
INPUT I/O POWER SUPPLY	VDDIO	-0.3	-	+7.0	V
ANALOG POWER SUPPLY	VDD	-0.3	-	+7.0	V
STATIC ELECTRICITY	Be sure that you are grounded when handling LCM.				

1.2 Electrical Characteristics

($T_a=25$)

ITEM	SYMBOL	CONDITION	MIN.	TYP.	MAX.	UNIT
CHARGE PUMP POWER SUPPLY	PVDD	-	3.2	3.3	3.4	V
INPUT I/O POWER SUPPLY	VDDIO	-	3.2	3.3	3.4	V
ANALOG POWER SUPPLY	VDD	-	3.2	3.3	3.4	V
INPUT HIGH VOL.	V_{IH}	-	0.7VDDIO	-	VDDIO	V
INPUT LOW VOL.	V_{IL}	-	GND	-	0.3VDDIO	V
OUTPUT HIGH VOL.	V_{OH}	-	0.9VDDIO	-	VDDIO	V
OUTPUT LOW VOL.	V_{OL}	-	GND	-	0.1VDDIO	V
SUPPLY CURRENT	$I_{PVDD} + I_{DD} + I_{DDIO}$	-	-	4	5.5	mA

* $I_{PVDD} + I_{DD} + I_{DDIO}$ Measurement condition is for all pixels on display

To avoid image residual, the same picture could not display to exceed one hour.

1.3 Interface Pin Function

NO	SYMBOL	I / O	FUNCTION
1.	VCOM	I	Common electrode driving voltage
2.	NC	-	DUMMY
3.	VGL	C	Negative low power supply for gate output
4.	C4P	C	Power setting capacitor connect pin
5.	C4N	C	Power setting capacitor connect pin
6.	VGH	C	Positive power supply for gate output
7.	FPR	O	Frame polarity output for VCOM
8.	VCAC	C	Define the amplitude of the VCOM swing
9.	VDDA	C	Intermediate voltage for charge Pump
10.	C3P	C	Power setting capacitor connect pin
11.	C3N	C	Power setting capacitor connect pin
12.	VINT	C	Intermediate voltage for charge Pump
13.	C2P	C	Power setting capacitor connect pin
14.	C2N	C	Power setting capacitor connect pin
15.	VCC	C	Intermediate voltage for charge Pump
16.	C1P	C	Power setting capacitor connect pin
17.	C1M	C	Power setting capacitor connect pin
18.	PVSS	P	Power Pump Power GND
19.	PVDD	P	Power Pump Power VDD
20.	DRV	O	Output the control signal for switching regulator for LED driving
21.	LED_Anode	P	For Led Anode voltage
22.	VSSA	P	Analog GND
23.	VFB	P	Main booster regulator feedback input
24.	VDD	P	Voltage supply pin for analog circuit
25.	VSS	P	Digital GND
26.	VDDIO	P	Digital interface power supply
27.	CS	I	Serial communication chip select

28.	SDA	I/O	Serial communication data input
29.	SCL	I	Serial communication clock input
30.	HSYNC	I	Horizontal sync input
31.	VSYNC	I	Vertical sync input
32.	DCLK	I	Clock input
33.	D7	I	Data input:MSB
34.	D6	I	Data input
35.	D5	I	Data input
36.	D4	I	Data input
37.	D3	I	Data input:
38.	D2	I	Data input
39.	D1	I	Data input:
40.	D0	I	Data input:LSB

I: Digital signal input, O: Digital signal output, G: GND, P: Power, C: Power set capacitor connect pin,

1.4 Power Supply for LCD Module

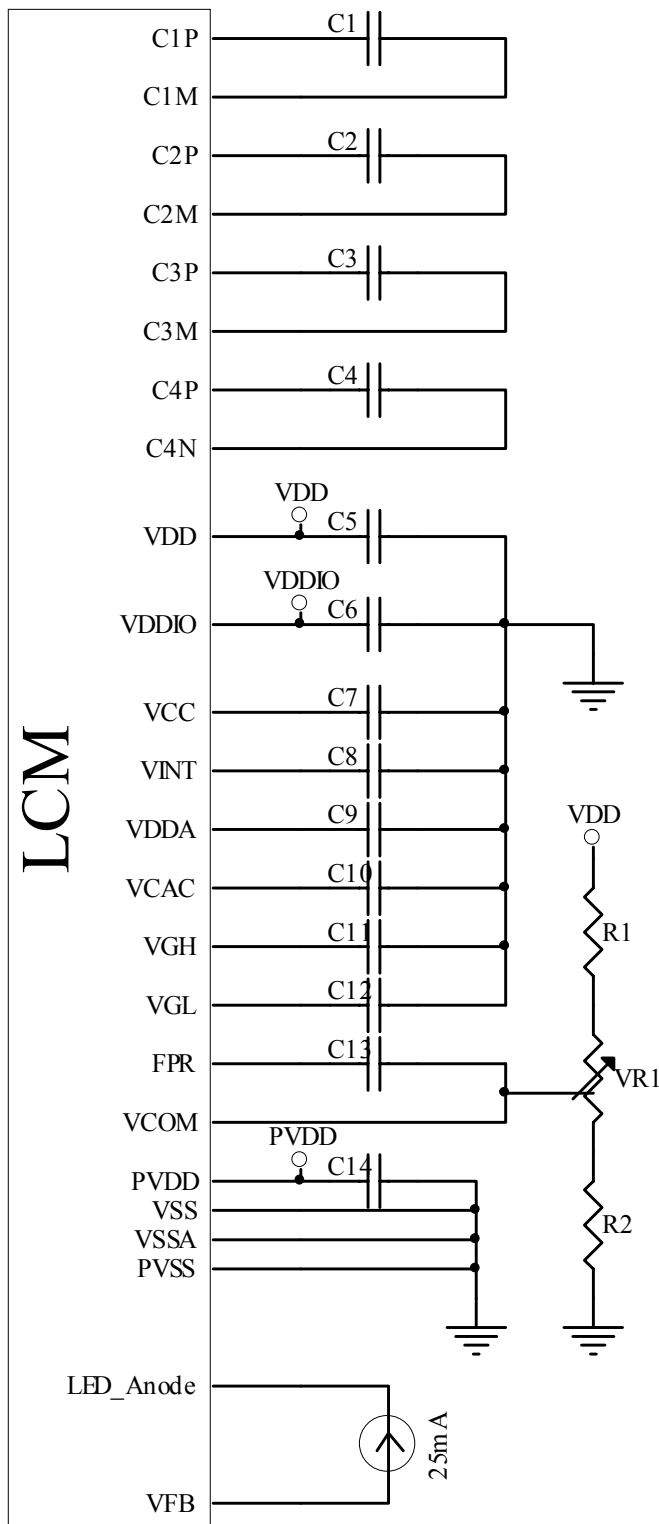

Note: PVDD=VDD=VDDIO=3.3V
 C1, C5~C7, C9~C10, C14 1uF/10V
 C2, C8 1uF/16V
 C3, C4, C11, C12 1uF/25V
 C13 4.7uF/10V
 VR1:1M, R1, R2:120K

1.5 Block Diagram with Display RAM Address

1.5-1. Block Diagram

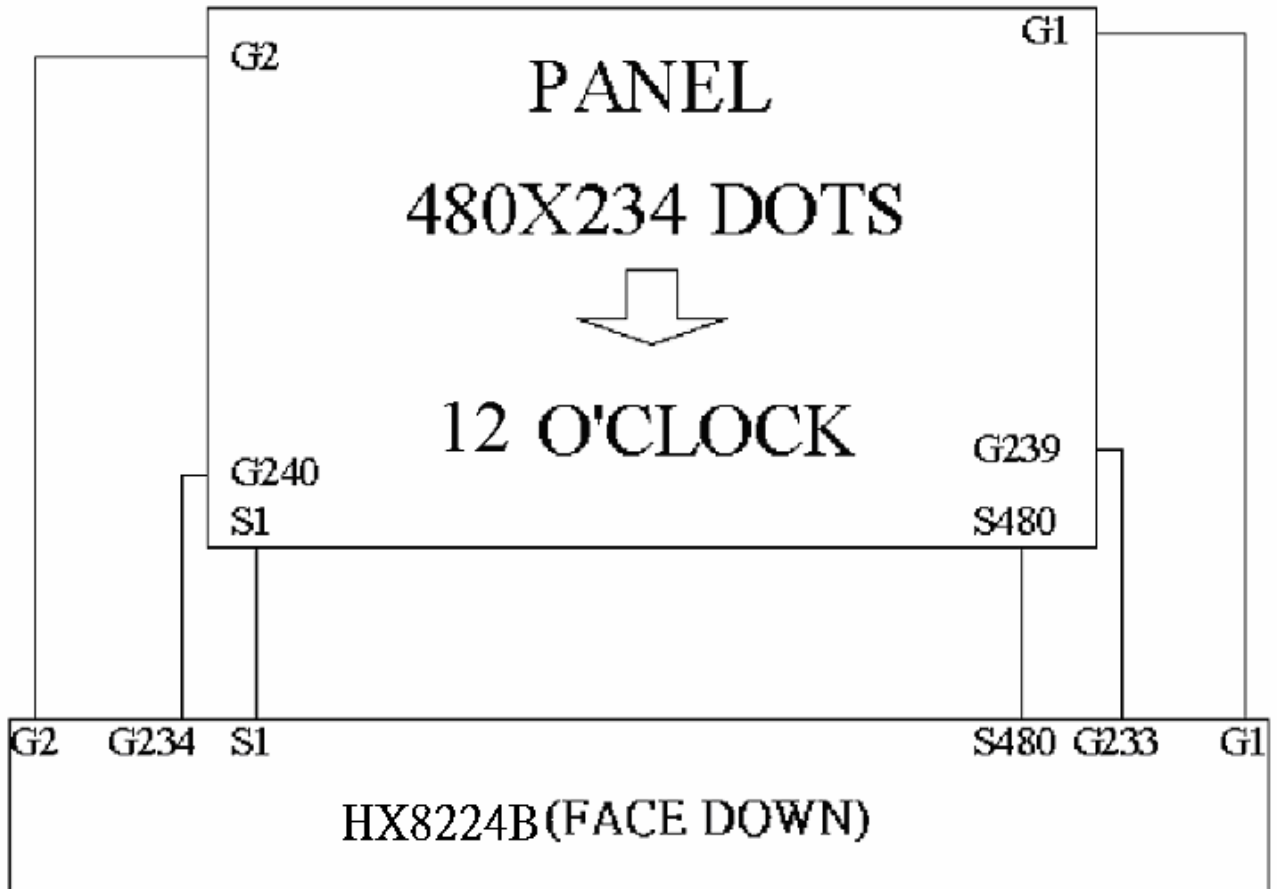

1.5-2. Initialization Table:

	Instruction	Code	Description
1.	System Control	0x0207	Charge Pump ON, DC-DC is ON ,Standby Mode OFF,
2.	Timing Controller Function	0x0611	Delta Mode ON,Dithering ON,Set CF Format to RGB(odd line)/GBR(even line)
3.	Operation Control	0x0a03	Normal VCOM Polarity,GO1-->G234,SO1-->SO480
4.	Input Data Format Control	0x0e00	HSD Negative Polarity,VSD Negative Polarity, Serial-RGB data format (HV mode), 9.7MHz
5.	Source Timing Delay Control	0x1200	Source Delay Timing=0 CLKIN
6.	Gate Timing Delay Control	0X1600	Gate Delay Timing=0 CLKIN
7.	VCOMAC Output Level Control	0X1a03	VCOMAC=4.4V

1.6 Timing Characteristic

Clock and Data Input Timing Diagram

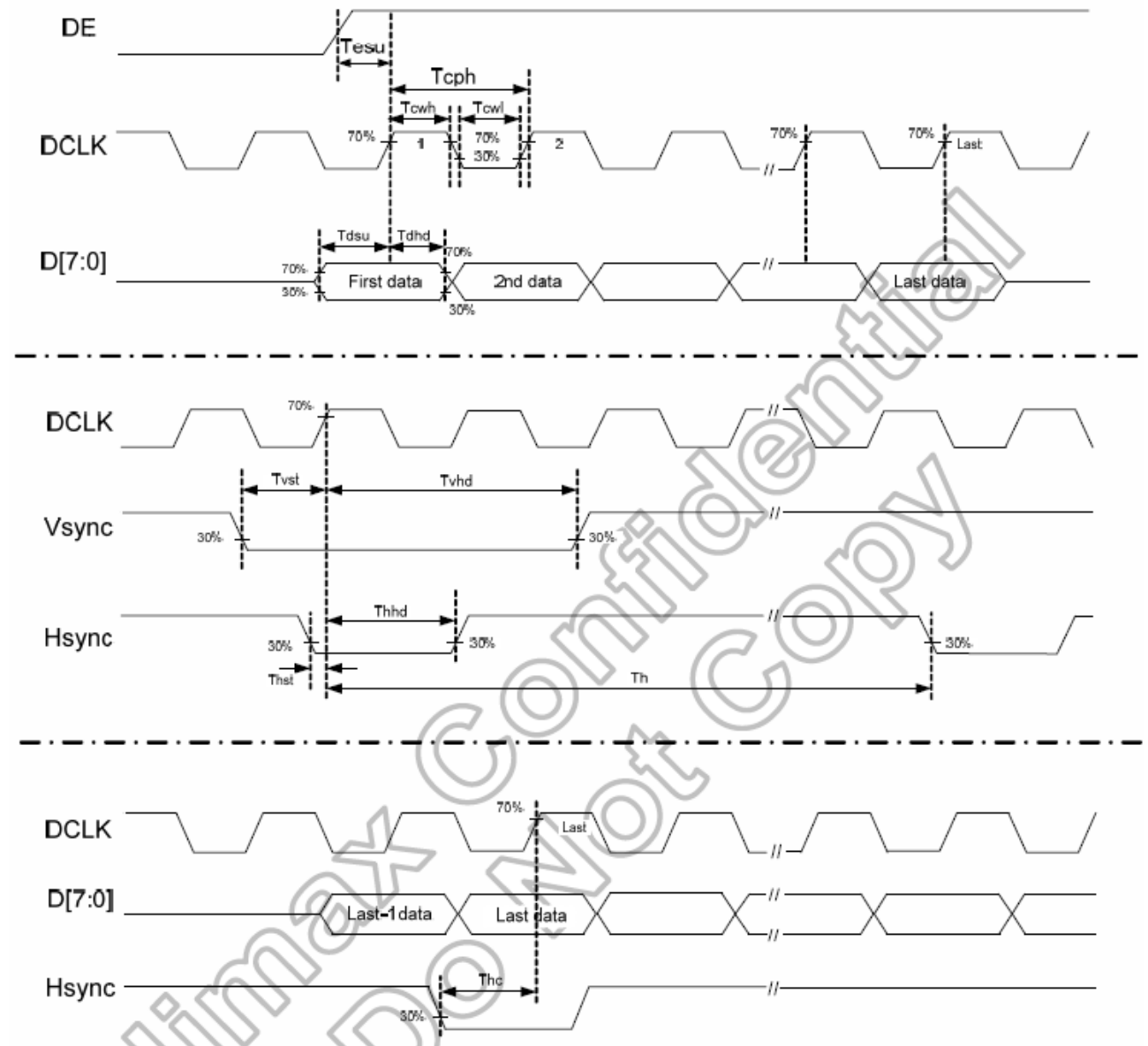

3-Wire Timing Diagram

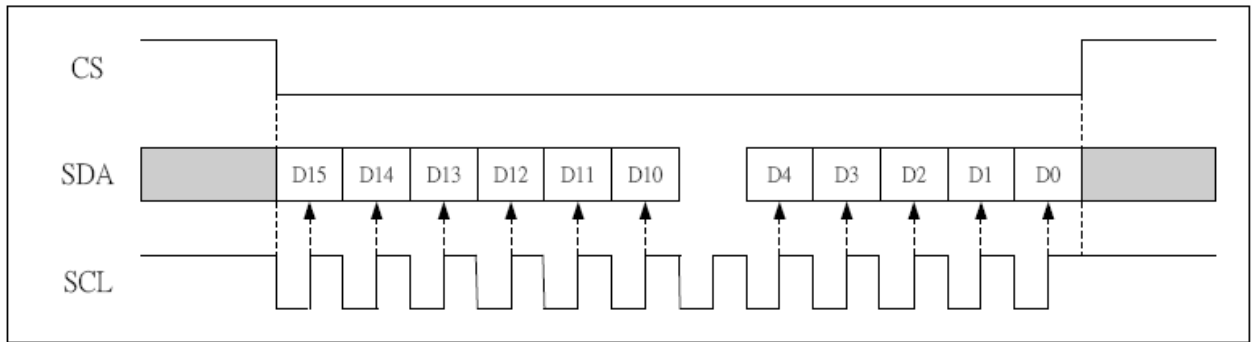

Figure 10.1 SPI Timing Diagram

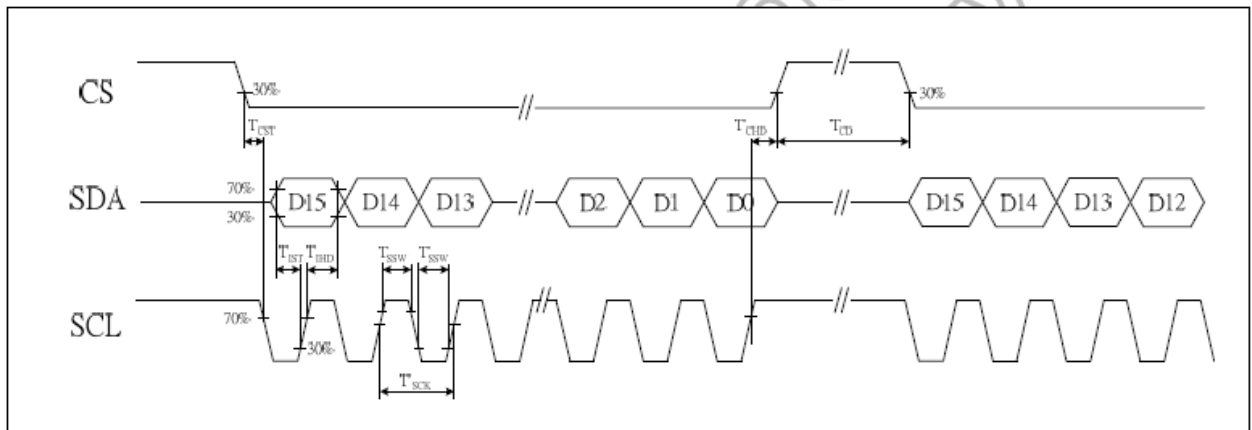

Figure 10.2 SPI Timing Diagram

AC Electrical Characteristics

Parameter	Symbol	Spec.			Unit
		Min.	Typ.	Max.	
Delay between Hsync and DCLK	T _{hc}	-	-	1	DCLK
Hsync width	T _{wh}	1	-	-	DCLK
Vsync width	T _{wv}	1	-	-	DCLK
Vsync setup time	T _{vst}	12	-	-	ns
Vsync hold time	T _{vhd}	12	-	-	ns
Hsync setup time	T _{hst}	12	-	-	ns
Hsync hold time	T _{hhd}	12	-	-	ns
Data set-up time	T _{dsu}	12	-	-	ns
Data hold time	T _{dhd}	12	-	-	ns
DE set-up time	T _{esu}	12	-	-	ns
Vsync period NTSC	T _v	250	262/262.5	360	Th
Vsync period PAL	T _v	300	312/312.5	360	Th
Hsync to Vsync time for ODD field	T _{HV O}	-4	-	+4	DCLK
Hsync to Vsync time for EVEN field	T _{HV E}	-	0.5	-	Th
S/D output stable time	T _{st}	-	-	30	μs
G/D output stable time	T _{gst}	-	-	2	μs

Serial communication

Parameter	Symbol	Spec.			Unit
		Min.	Typ.	Max.	
Serial clock period	T _{sck}	100	-	-	ns
Serial clock duty cycle	T _{scw}	40	50	60	%
Serial clock width	T _{ssw}	40	-	-	ns
Serial data setup time	T _{lst}	40	-	-	ns
Serial data hold time	T _{lhd}	40	-	-	ns
SPENB setup time	T _{cst}	40	-	-	ns
SPENB data hold time	T _{chd}	40	-	-	ns
Chip select distinguish	T _{cd}	1	-	-	μs

1.7 Power ON/OFF SEQUENCE

1.7.1 Power ON/OFF Sequence

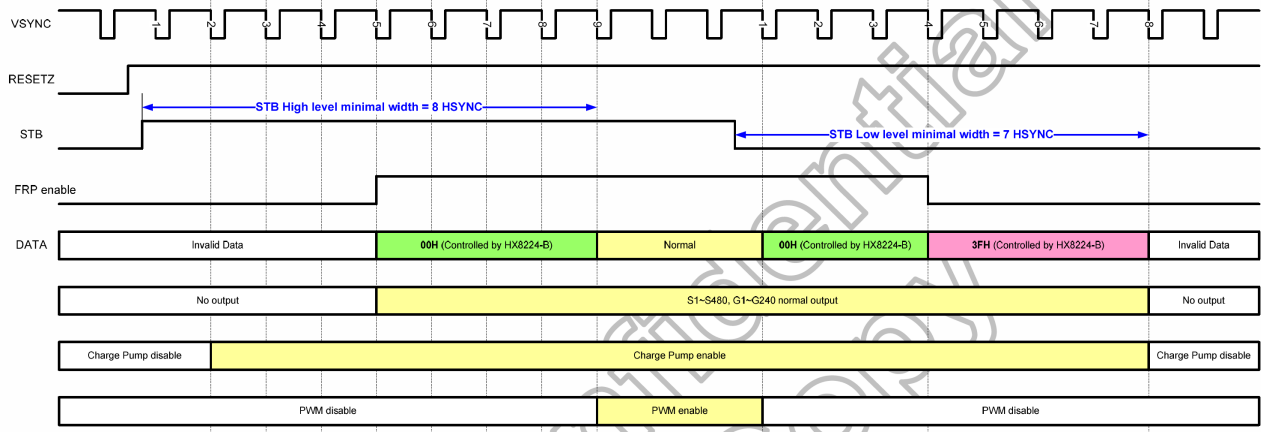

Figure 5.2 Power on/off sequence timing diagram

(2) Electro-optical Units

2.1 Electro-optical Characteristics

ITEM	SYMBOL	CONDITION	MIN.	TYP.	MAX.	UNIT
Viewing Angle (C.R. ≥ 10)		= 0 ° 6H	45	-	-	deg.
		= 180 ° 12H	15	-	-	
		= 90 ° 3H	45	-	-	
		= 270 ° 9H	45	-	-	
CONTRAST RATIO	CR	Transmissive(Ta=25)	150	-	-	-
RESPONSE TIME	Tr+Td	Ta=25	-	25	-	Ms
White x-coord	Wx		0.25	0.31	0.37	
White y-coord	Wy		0.27	0.33	0.39	
LCD TYPE	TFT (Positive / Transmissive)					
VIEWING DIRECTION	12 O'CLOCK					

Notes : All the optical data should be measured when the display's driven under the "Typ" condition.

2.2 Optical Definitions

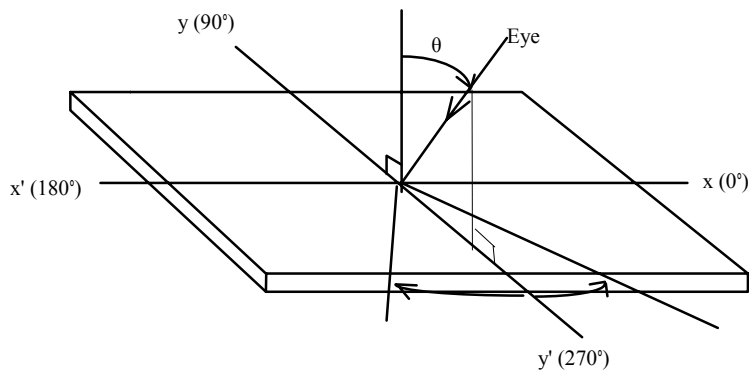
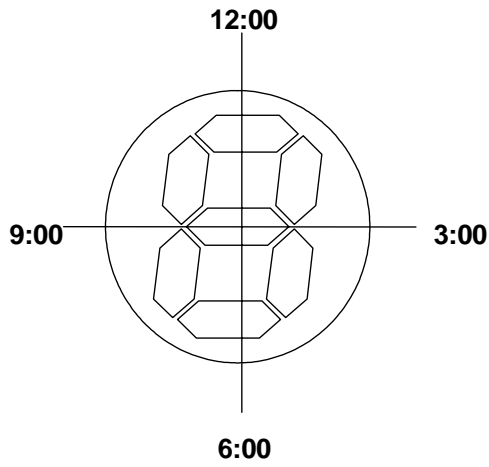

View Angle

(3) Mechanical Units

3.1 Mechanical Diagram

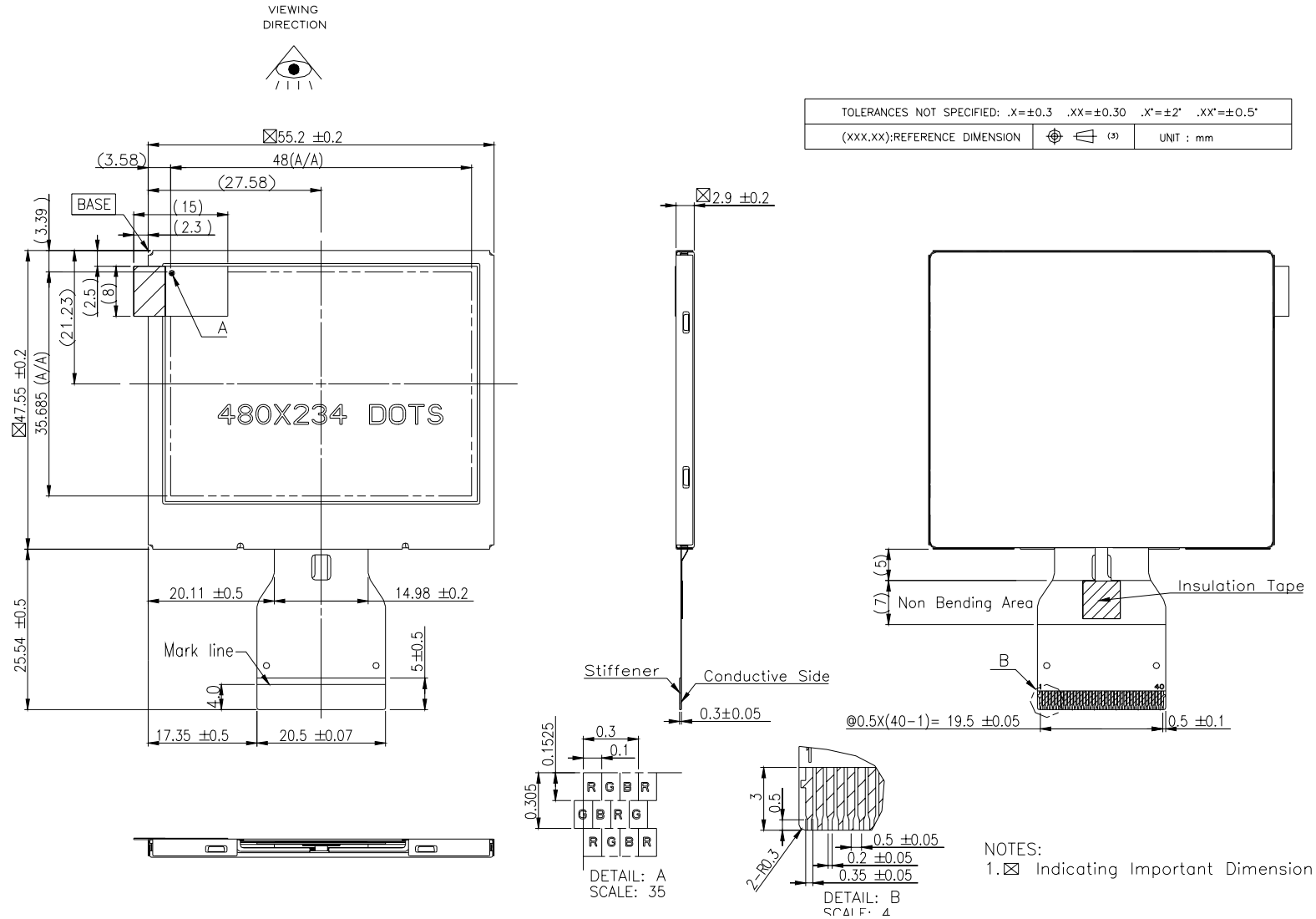

3.2 Back-light Specification

LED Backlight Styles:

The LED chips are distributed over the whole light area of the illumination unit, which gives the most uniform light.

3.2-1. Data About LED Backlight

PARAMETER	SYMBOL	MIN.	TYP.	MAX.	UNIT	TEST CONDITION	NOTE
Backlight type	LED (White)						
Supply Current	I_{LED}	-	25	-	mA	-	$V_{AK} \leq 4.4V$
Reverse Voltage (Single chip)	V_R	-	-	5.0	V	-	-
Luminous Intensity	I_v	200	250	-	cd/m ²	$I_{LED}=25mA$	1 (With LCD)
Luminous Intensity Ratio	-	-	-	30	%	$I_{LED}=25mA$	2

NOTE : 1. Average Luminous Intensity of P1 – P9
 2. Luminous Intensity Ratio = (MAX-MIN)/ MAX.

3.2-2. Internal Circuit Diagram

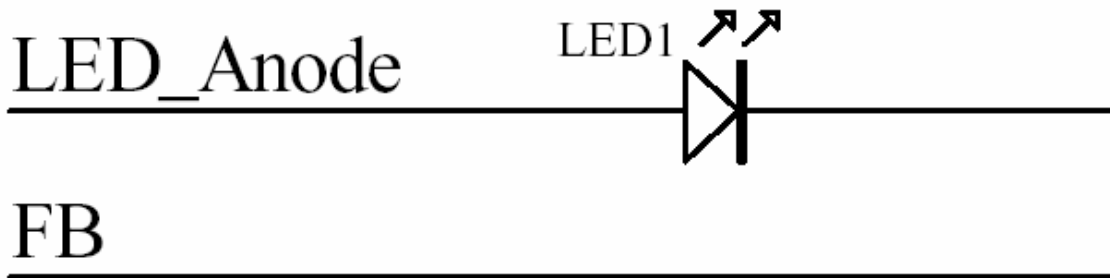

3.2-3. MEASURED METHOD (X*Y: Light Area)

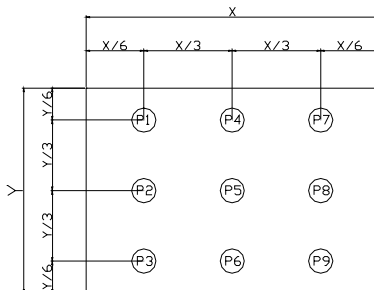

(Effective spatial Distribution)

Hole Diameter $\phi 3mm$; 1 to 9 per Position Measured Luminous Intensity Ratio

3.3 Packing Method

1. Packaging Material : (per carton)						
NO.	Item	Model	Dimensions (mm)	Unit Weight (Kg)	Quantity	
1	LCM Module	WM-F4823V4	55.2*47.55	0.01	648	
2	Tray	VK28-1	PS	320*217*12*0.6	0.06	60
3	Product Box	C01	320*219*70	0.131	6	
4	Carton	C62	475*345*250	0.857	1	
5	Package Bag	C5	467*321*0.08	0.023	6	
6	Total Weight	11.9	Kg± 5%			
2. Packaging Specifications and Quantity :						
(1) LCM quantity per tray : quantity per row		4	x quantity per column	3	= 12	
(2) LCM quantity per box : quantity per tray		12	x quantity of trays	9	= 108	
(3) Total LCM quantity in carton : quantity per box		108	x quantity of boxes	6	= 648	
<p>Use empty tray</p> <p>Put products into the tray</p> <p>Tray stacking</p> <p>Use P.P strap</p> <p>Use package bag</p> <p>QC inspection label</p> <p>The tape to seal carton</p> <p>Carton label</p> <p>Rotate tray 180 degrees and place on top of stack. Check the tray stack using Fig. B.</p> <p>P.P strap width = 6mm</p>						
3. Label Specifications :					Remark	
(1) QC Inspection Label						
					Label Color----Green	
(2) Carton Label						
					Label Color----White	

(4) Quality Units

4.1 Specification of Quality Assurance

4.1-1.Purpose

This standard for Quality Assurance should affirm the quality of LCD module products to supply to purchaser by WINTEK CORPORATION (Supplier).

4.1-2.Standard for Quality Test

a. Inspection :

Before delivering, the supplier should take the following tests, and affirm the quality of product.

b. Electro-Optical Characteristics:

According to the individual specification to test the product.

c. Test of Appearance Characteristics:

According to the individual specification to test the product.

d. Test of Reliability Characteristics:

According to the definition of reliability on the specification for testing products.

e. Delivery Test:

Before delivering, the supplier should take the delivery test.

(i) Test method: According to **ANSI/ASQC Z1.4-2003.General Inspection Level take a single time.**

(ii) The defects classify of AQL as following:

Major defect: AQL=0.65

Minor defect: AQL=2.5

Total defects: AQL=2.5

4.1-3.Nonconforming Analysis & Deal With Manners

a. Nonconforming analysis:

(i) Purchaser should supply the detail data of non-conforming sample and the non-suitable state.

(ii) After accepting the detail data from purchaser, the analysis of nonconforming should be finished in two weeks.

(iii) If supplier can not finish analysis on time, must announce purchaser before two weeks.

b. Disposition of nonconforming:

(i) If find any product defect of supplier during assembly time, supplier must change the good product for every defect after recognition.

(ii) Both supplier and customer should analyze the reason and discuss the disposition of nonconforming when the reason of nonconforming is not sure.

4.1-4. Agreement items

Both sides should discuss together when the following problems happen.

- a. There is any problem of standard of quality assurance, and both sides think that it must be modified.
- b. There is any argument item which does not record in the standard of quality assurance.
- c. Any other special problem.

4.1-5. Standard of The Product Appearance Test

a. Manner of appearance test:

- (i) The test must be under 20W x 2 or 40W fluorescent light, and the distance of view must be at 30 cm.
- (ii) When display on use front-light test, while display off use back-light test.
- (iii) The test direction is base on about around 45° of vertical line.

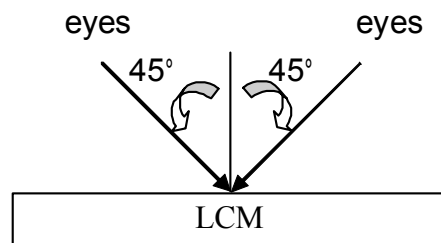

(iv) Definition of area:

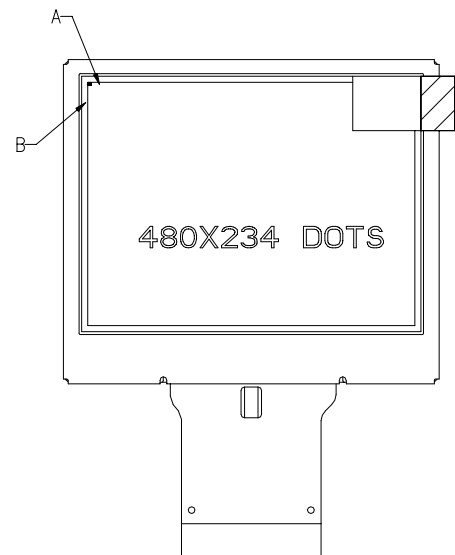

A Area : Viewing area.

B Area : Out of viewing area.
(Outside viewing area)

b. Basic principle:

- (i) It will accord to the AQL when the standard can not be described.
- (ii) The sample of the lowest acceptable quality level must be discussed by both supplier and customer when any dispute happened.
- (iii) Must add new item on time when it is necessary.

c. Standard of inspection:(Unit: mm)

4.1-6. Inspection specification

NO	Document Number	Attachment file
1	M1L070012	

4.2 Standard Specification for Reliability

4.2-1. Standard Specifications for Reliability of LCD Module

No	Item	Description
01	High temperature operation	Operating temperature (high) of the sample should be allowed to stand for 240 hours under driving condition.
02	Low temperature operation	Operating temperature (low) of the sample should be allowed to stand for 240 hours under driving condition.
03	High temperature resistance	Storage temperature (high) of the sample should be allowed to stand for 240 hours under no-load condition, and then returning it to normal temperature condition, and allowing it stand for 30 minutes.
04	Low temperature resistance	Storage temperature (low) of the sample should be allowed to stand for 240 hours under no-load condition, then returning it to normal temperature condition, and allowing it stand for 24 hours.
05	Moisture resistance	The sample should be allowed to stand at 60 , 90% RH MAX for 240 hours under no-load condition excluding the polarizer, then taking it out and drying it at normal temperature.
06	Thermal shock resistance	The sample should be allowed to stand the following 50 cycles of storage: Storage temperature (low) for 30 minutes → normal temperature for 5 minutes → storage temperature (high) for 30 minutes → normal temperature for 5 minutes , as one cycle.

Notes : Please refer to section 1.1 Absolute Maximum Ratings to mention the operating temperature and storage temperature.

4.2-2. Testing Conditions and Inspection Criteria

For the final test the testing sample must be stored at room temperature for 24 hours, after the tests listed in Table 4.2, Standard specifications for Reliability have been executed in order to ensure stability.

NO	Item	Test Model	Inspection Criteria
01	Current Consumption	Refer To Specification	The current consumption should conform to the product specification.
02	Contrast	Refer To Specification	After the tests have been executed, the contrast must be larger than half of its initial value prior to the tests.
03	Appearance	Visual inspection	Defect free.

4.2-3. Life Time

Life time	Functions, performance, appearance, etc. shall be free from remarkable deterioration within 50,000 hours under ordinary operating and storage conditions room temperature (25 ± 10), normal humidity ($45 \pm 20\%$ RH), and in area not exposed to direct sun light. (Life time of backlight, please refer to “ Data about backlight “.)
-----------	--

Note: From our experience the life time of high humidity operation and high temperature operation as above mentioned could be achieved.

4.3 Precautions in Use of LCM

4.3-1 Handling of LCM

- Don't give external shock.
- Don't apply excessive force on the surface.
- Liquid in LCD is hazardous substance. Must not lick and swallow. when the liquid is attach to your hand, skin, cloth etc. Wash it out thoroughly and immediately.
- Don't operate it above the absolute maximum rating.
- Don't disassemble the LCM.

4.3-2 Storage

- Store in an ambient temperature of 5 to 45 , and in a relative humidity of 40% to 60%. Don't expose to sunlight or fluorescent light.
- Storage in a clean environment, free from dust, active gas, and solvent.
- Store in anti-static electricity container.
- Store without any physical load.

4.3-3 Soldering

- Use the Sn-Ag-Cu (96.5, 3.0, 0.5) solder
- Iron : Temperature 300 and less than 5-6 sec during soldering.
- Rewiring : no more than 3 times.

4.3-4 Assembly

- The front polarizer is covered with a protective foil which should be removed before use.

(5) Substance Management Units

5.1 Product Substances Management Documentation

NO	Document Number	Attachment file
1	Environment management standard (EMS-P-017-01)	

Note : Details of control substance and apply threshold for “Product Substances Management Documentation” please refer to the following attachment file.