



Service Manual

MODEL: DV-700S



CONTENTS

SPECIFICATIONS.....	2
ADVANTAGES OF THIS PRODUCT.....	3
CIRCUIT OPERATIONAL DESCRIPTION.....	4
VOLTAGE CHARTS.....	17
CIRCUIT DIAGRAM.....	18
PCB CIRCUIT BOARD.....	27
INSTRUMENT DISASSEMBLY.....	31
PARTSLIST.....	35

! Caution :

In this Manual, some parts can be changed for improving.

SPECIFICATIONS

Laser		wavelength 650nm
Video		PAL/AUTO/NTSC
Frequency response		20Hz ~ 20KHz (± 1 dB)
Signal/noise ratio		≥ 90 dB
Channel separation		≥ 85 dB (1KHz)
Dynamic range		≥ 80 dB (1KHz)
Output Audio	Analog	output level : $2.0 + 0/-0.2V_{rms}$ (Load impedance : $10K\Omega$)
	Digital	output level : $0.5 \pm 0.1V_{p-p}$ (Load impedance : 75Ω)
Output Video	Composite	output level : $1.0 \pm 0.1V_{p-p}$ (Load impedance : 75Ω , imbalance, negative polarity)
	S-video	output level : brightness (Luma) $1.0 \pm 0.1V_{p-p}$ chromaticity (Colour) $0.286 \pm 20\%$ (load impedance: 75Ω)
	RGB	$0.5 V_{p-p}$ 75% white
Power supply		100-240V~, 50/60Hz
Power consumption		< 12W
Dimensions (W x H x D)		430 x 38 x 260 mm
Weight (Gross/ Net)		About 3.5Kgs/ 2.6Kgs

Notes : Design and specifications in this owner's manual are subjected to change without prior notice to improve quality and function.

DVD Audio output standards

Output	Disc type		
	DVD	VIDEO-CD	CD
Analogue Audio output	48/96KHz sampling	44.1KHz sampling	44.1KHz sampling
Digital Audio output	48KHz sampling	44.1KHz sampling	44.1KHz sampling

ADVANTAGES OF THIS PRODUCT

- DVD, VCD, CD, CD-R, CD-RW, MP3, PIC-CD, CD+G playback function
- Integrated remote control
- Multiplex sound playback
- Mp3 file playback function
- GUI (Graphical User Interface) OSD (On Screen Display)
 - By using the [DISPLAY] button on the remote control, information on the DVD/VCD/CD player and disc, can be displayed on the TV screen.
- Screensaver function (DVD)
- 3D sound (3D sound effect using 2 speakers)
- Coaxial digital output (PCM, Dolby Digital, DTS)
 - You can enjoy high-level digital audio by connecting with amp embedded with Dolby Digital / DTS decoder.
- Built-in Dolby Digital decoder
- Analog audio 2-channels output for DOWNMIX (x1)
- Composite video out (x1)
- Slow Forward / Reverse (DVD) playback
- Fast Forward / Reverse playback
- Search of title, chapter, and time in DVD disc, and search of track and time in VCD and CD
- Repeat playback (title and chapter for DVD, track and disc for VCD/CD)
- Repeat a defined period from A to B (DVD)
- Selective Play (DVD/VCD/CD)
 - You can select and play the desired title / chapter of DVD and track of Video CD
- Various languages OSD (On Screen Display) function (DVD)
 - You can select and display OSD among various languages. (English, French, Spanish)
- Parental Lock function (DVD)
 - This function can prevent playback of software that may be unsuitable for children.
- Multi Audio function (DVD)
 - The audio soundtrack can be heard in up to 8 languages. In the case of SVCD or VCD, it depends on the disc. (The number of audio languages depends on the software.)
- Multi Subtitle function (DVD)
 - The subtitle can be seen in up to 32 languages. In the case of SVCD or CVD, it depends on the disc. (The number of subtitle languages depends on the software.)
- Multi Angle function (DVD)
 - This function allows you to choose the viewing angle of scenes which were shot from a number of different angles. (The number of angles depends on the software.)
- Screen zoom function (DVD/VCD)

CIRCUIT OPERATIONAL DESCRIPTION

DVD Module

1. Summary

DVD One Board consists of: Loader part that reads and transmits audio and video data saved at Optic Discs (DVD, CD-DA, VCD, CD-R) to MPEG Decoder part; MPEG Decoder part, which, by decoding and encoding data received from the Loader, produces analog signals; and u-Com that controls the overall system including the loader and MPEG decoder.

2. How Does it Operate

Insert the power cord and then power transmitted to each IC, and the SET will be the STANDBY status which requires the least power for input the front panel key, input the STAND BY/ON key, extinguished the LED. Once the Power On key is entered, u-Com recognizes it and initiates each chipset, performs sequential algorithms such as determining whether the disc is in or not, and if in, what type of disc is loaded. Through this process, it can read disc data before transmitting it to the MPEG Decoder. The MPEG Decoder will then decode and encode such data before generating the final analog audio and video signal outputs.

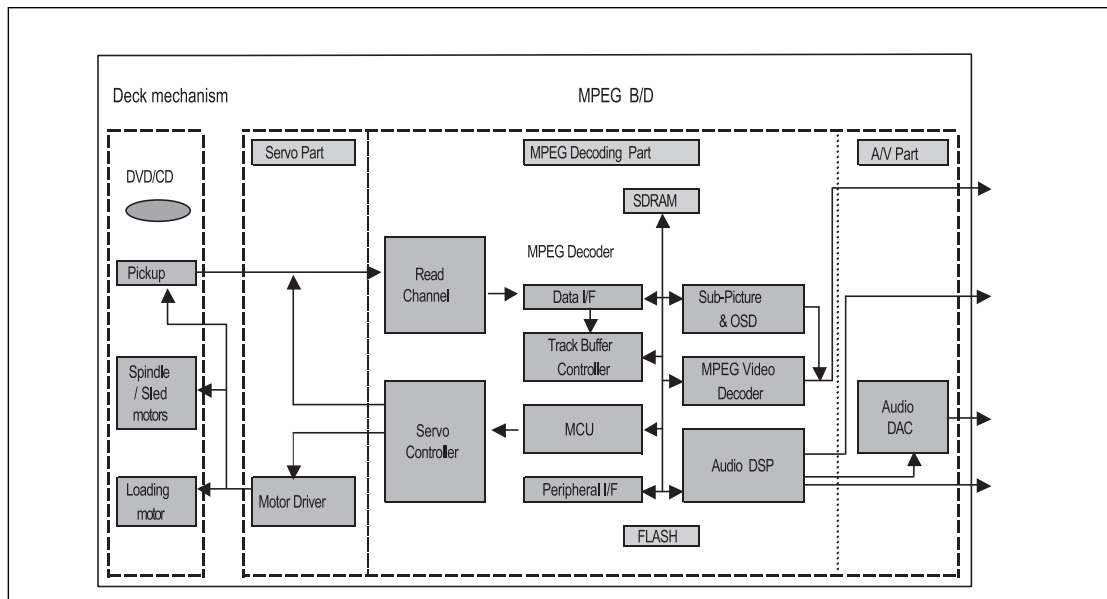

DVD-MODULE Block Diagram

3.Loader Part

The loader which read the data of audio/video from optic disc and transfer them to MPEG decoder can be divided into Deck total DVD assay(in a short term, Mecha) and Servo. Mecha mounts with the optical pick-up which allows reading the signal of a disc using laser beam and makes it operates and consists of the deck mechanism which allows loading a disc and reading the data. Servo is a sort of circuit which allows operating the loader and recovering the data and consists of Motor Drive IC operating the spindle, the sled, the loading motor.

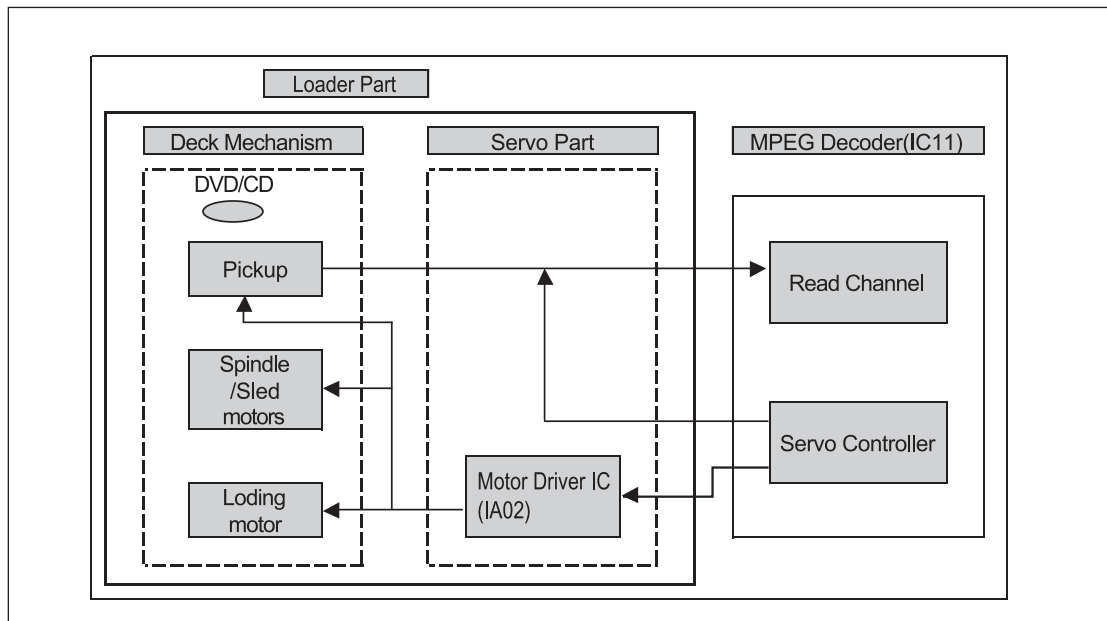

Loader Block Diagram

CIRCUIT OPERATIONAL DESCRIPTION

1) Motor Drive IC: AT5868S

The AT5868S is a 5-channel BTL driver IC for driving the motors and actuators in products such as CD-ROM/DVD-ROM/DVD-Player drives. Two of the channels use current feedback to minimize the current phase shift caused by the influence of load inductance. Driver IC generates the focus signal and the tracking signal for pick-up actuator, the sled signal for feed, spindle signal and the load signal for opening and closing of the tray. The focus signal, the tracking signal, the sled signal and the spindle signal are input into each relaxant port of the drive IC (in the order of No. 26 pin, 23, 4, and 1) and set the gain amplification and the center voltage through the internal OP-AMP and drive on both sides and then the focus signal and the tracking signal will be output as VOFC+, VOFC- and VOTK+, VOTK- on actuator, the sled signal and the spindle signal will be output as VOSL+, VOSL- and VOLD+, VOLD- on each motor. For the load signal the input opening/closing signal is output as VOTR+, VOTR- through the loading PRE FWD REV circuit.

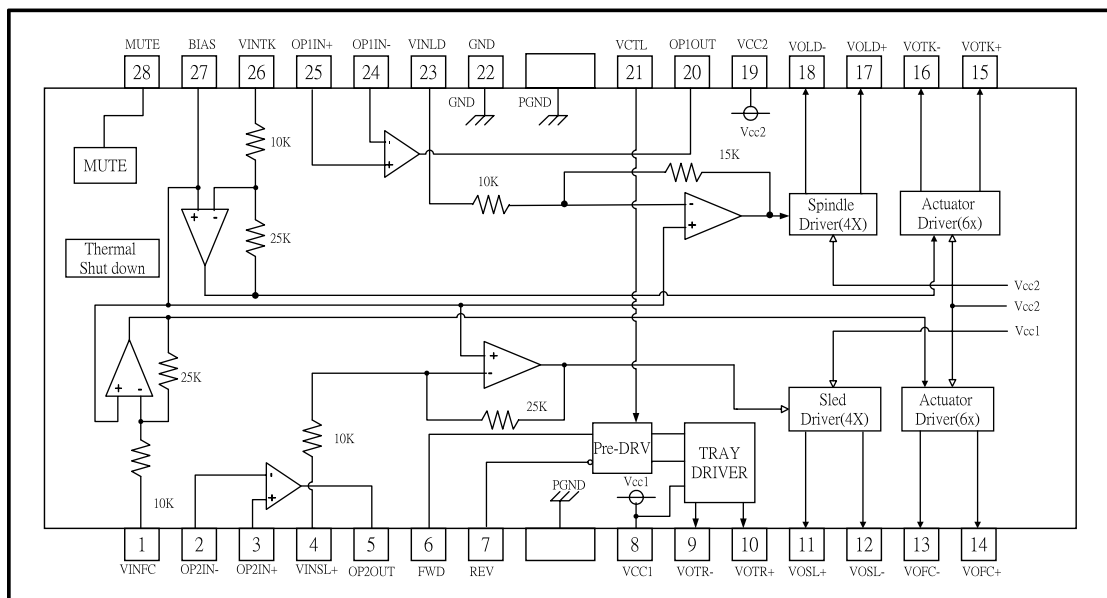

Motor Drive IC (AT5868S) Block Diagram

MPEG Decoder

The signal read from DVD disc is output into the RF signal and Servo related signal through the RF IC and they are input into the MPEG decoder and processed the MPEG decoding and divided into video/audio signal. The video signal is output into the analog audio signal through the built-in encoder block and also the audio signal into the audio DAC through the audio decoder block.

MPEG decoder consists of existing MPEG-2 decoder and single chip combined the digital signal processing part which is the core technology of DVD player with the Servo controller.

1. DVD Servo And MPEG-2/MPEG-4/DIVX Decoder : ES6698

The ES6698 Vibratto™II processor is a highly integrated single-chip DVD solution that integrates read channel, ECC, Servo DSP, MCU, and MPEG-2/MPEG-4/DivX decoder that has a state-of-the-art 480p/576p progressive-scan video feature to provide brilliant and sharp, flicker-free video output to the display, and with built-in gamma correction and S/PDIF input and output support. The ES6698 performs audio/video stream data processing, TV encoding, Macrovision™ copy protection, DVD system navigation, system control, and housekeeping functions.

The Vibratto-II DVD processor is built on the ESS proprietary dual CPU Programmable Multimedia Processor(PMP) core consisting of 32-bit RISC and 64-bit DSP processors and offers the best DVD feature set. The processing units enable simultaneous parallel execution of system commands and data processing to perform specialized encoding and decoding tasks.

The RISC processor performs bit stream parsing, control audio data output, transfer video and audio data to the vector engine and service system control and housekeeping functions. The vector engine performs audio and video micro-code processing required by A/V standards, such as Dolby Digital®, MPEG and JPEG imaging. These processing tasks include video motion compensation and estimation, loop filtering, Discrete Cosine Transforms(DCT), inverse DCT, quantization, and inverse quantization.

The Vibratto-II DVD processor supports all popular pick-up units, industry standard I²S audio data input and output, EPROM and DRAM access. It also supports both letterbox and pan-and-scan displays, sub-picture overlay, and On-Screen Display(OSD).

The Vibratto-II's Unified Memory Architecture enables the lowest possible system memory cost by consolidating multiple memory subsystems into a single unit.

In addition, the Vibratto-II DVD solution offers support for Karaoke CD+G, DVD-Audio, HDCD, CD-DA, Mp3, and WMA.

The ES6698 Vibratto-II DVD processor with DTS support is offered with the ES6698D, which has the same pinout as the standard ES6698. DTS support is provided via software and only works with the ES6698 and ES6698D DVD processors are available in 2 208-pin Plastic Quad Flat Pack(PQFP) device package.

CIRCUIT OPERATIONAL DESCRIPTION

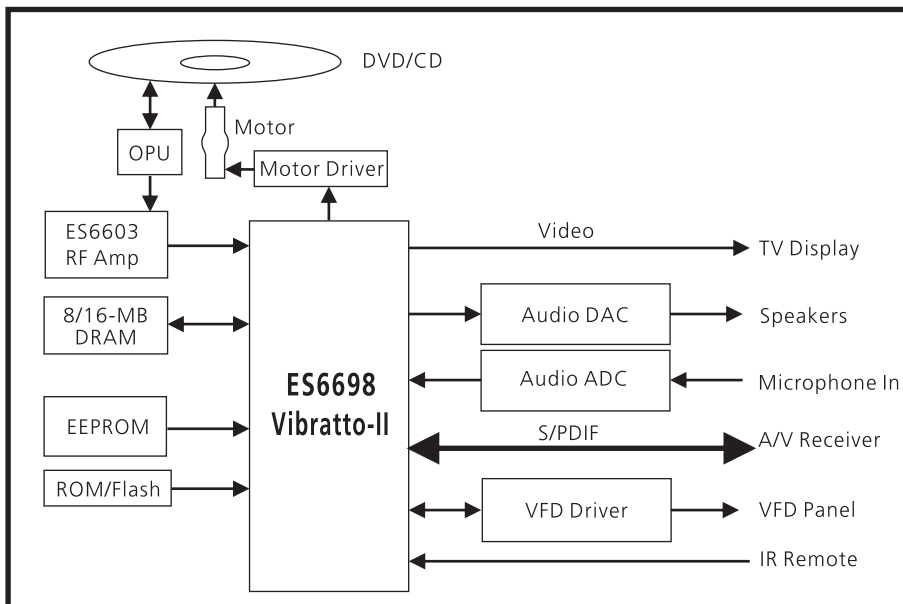

ES6698 Vibratto-II system Block Diagram

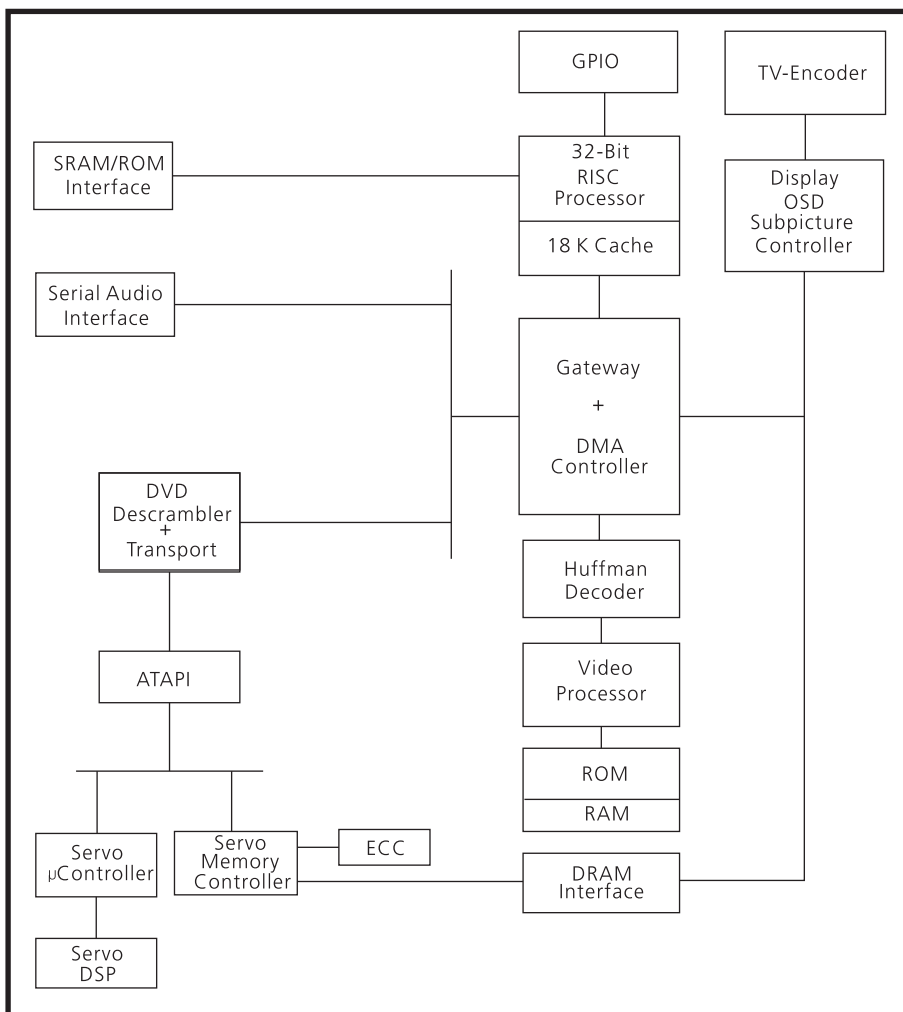

ES6698 Vibratto-II Block Diagram

2. DVD Servo AFE IC : ES6603

The ES6603 is a high-performance, single-chip analog front-end (AFE) device that contains the servo functions, RF attenuator, automatic gain controller (AGC), and programmable equalizer/filter for a DVD player system, and dual auto laser power control circuit to support twin pickups or twin laser systems.

The ES6603 incorporates a bi-directional serial port for accessing the programmable functions of the internal AGC, including attenuation and boost/equalization.

The DVD servo block of the ES6603 includes mirror detection, defect detection, dual auto laser power control, focus error, center error, and tracking error detection circuits. The ES6603 provides AC-coupled voltage inputs for photo detector signals used to detect center error, focusing error, tracking error, and differential phase tracking error detection for DVD.

The ES6603 also provides an AC-coupled differential or single-ended RF signal input to the programmable attenuator with external AC coupling circuitry, and an AC-coupled single-ended input for RF signals. The attenuator outputs are AC-coupled to the AGC inputs. The AC-coupled DVD and CD inputs are multiplexed in the input stage for accurate error detection.

The programmable bandwidth and boost/equalization of the ES6603 is provided by internal 7-bit control DACs, while a variable attenuator is used to program the zero locations. The programmable bandwidth and cutoff range are set by the filter cutoff DAC. Signal equalization with the programmable filter is supported with a wide bandwidth fullwave rectifier and a dual rate charge pump.

The ES6603 also provides inputs for its internal RF summing mode. These inputs have the gain control amplifiers at the input stage. The gain is controlled by the register bit settings of the serial port.

The ES6603 is available in an industry-standard 64-pin low-profile quad flat pack (LQFP) package.

CIRCUIT OPERATIONAL DESCRIPTION

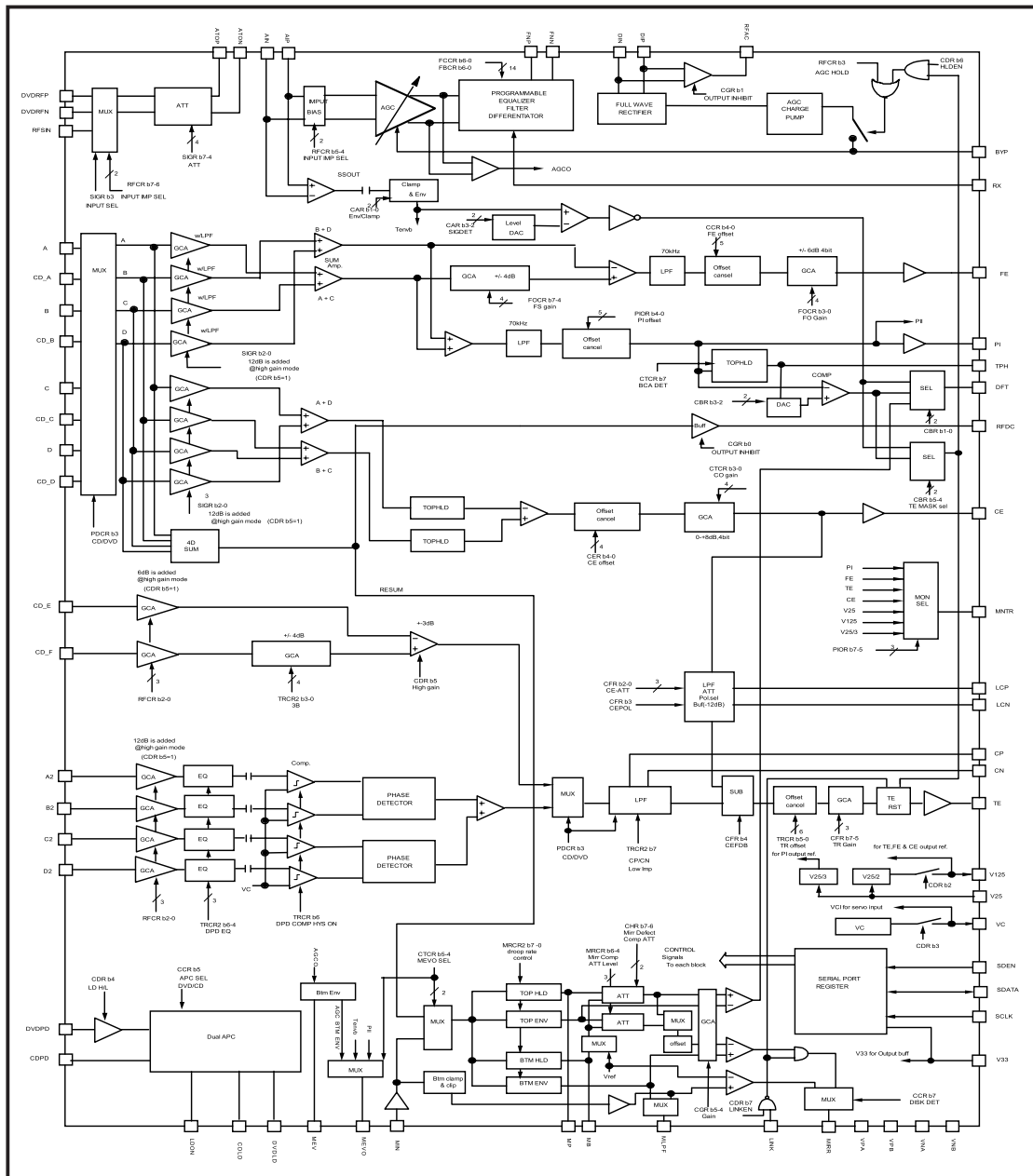

DVD Servo AFE IC : ES6603 Block Diagram

CIRCUIT OPERATIONAL DESCRIPTION

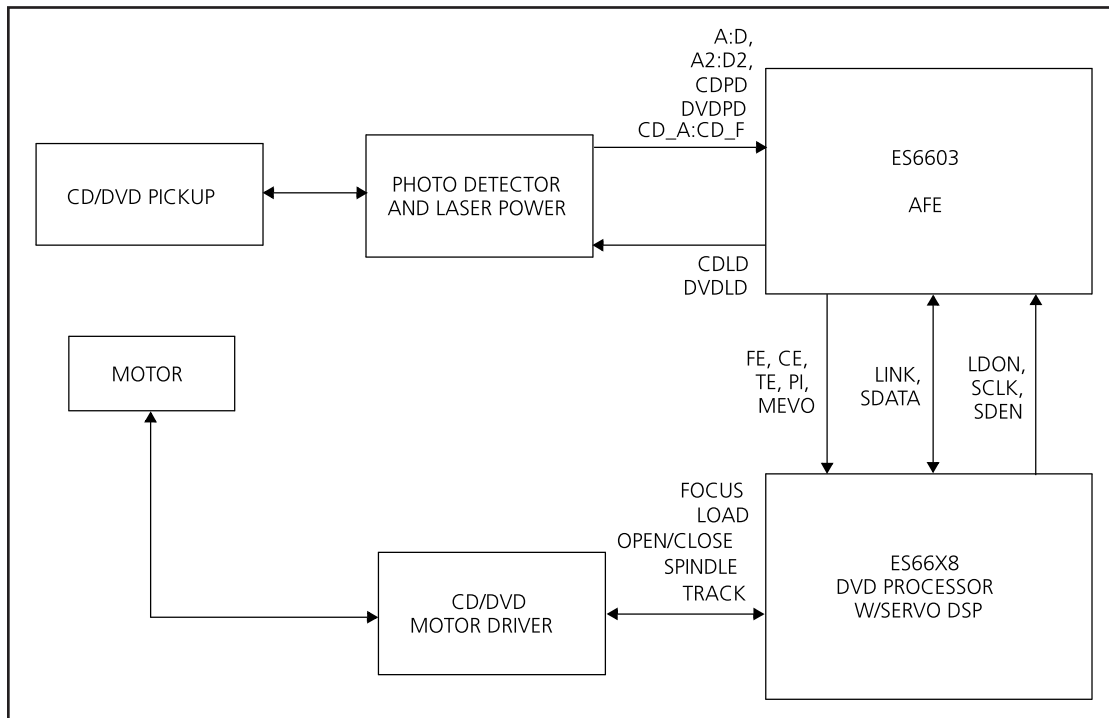

ES6603/ES66x8 Block Diagram

CIRCUIT OPERATIONAL DESCRIPTION

3. Flash Memory : A29800UV-70(A29800TV-70/AT49F8192AT/HY29F800ABT-70)

This stores every program required for the operation of DVD player and holds the data of OSD languages and LOGO and send them upon request from u-COM. This allows the update of firmware by CD-R/RW. For DVD module.

Description

The A29800UV-70 is a 5.0 volt only Flash memory organized as 1048,576 bytes of 8 bits or 524,288 words of 16 bits each. The A29800UV-70 offers the RESET function. The 1024 Kbytes of data are further divided into nineteen sectors for flexible sector erase capability. The 8 bits of data appear on I/O₀- I/O₇ while the addresses are input on A1 to A18; the 16 bits of data appear on I/O₀~I/O₁₅. . The A29800UV-70 is offered in 44-pin SOP and 48-Pin TSOP packages. This device is designed to be programmed in-system with the standard system 5.0 volt VCC supply. Additional 12.0 volt VPP is not required for in-system write or erase operations. However, the A29800UV-70 can also be programmed in standard EPROM programmers.

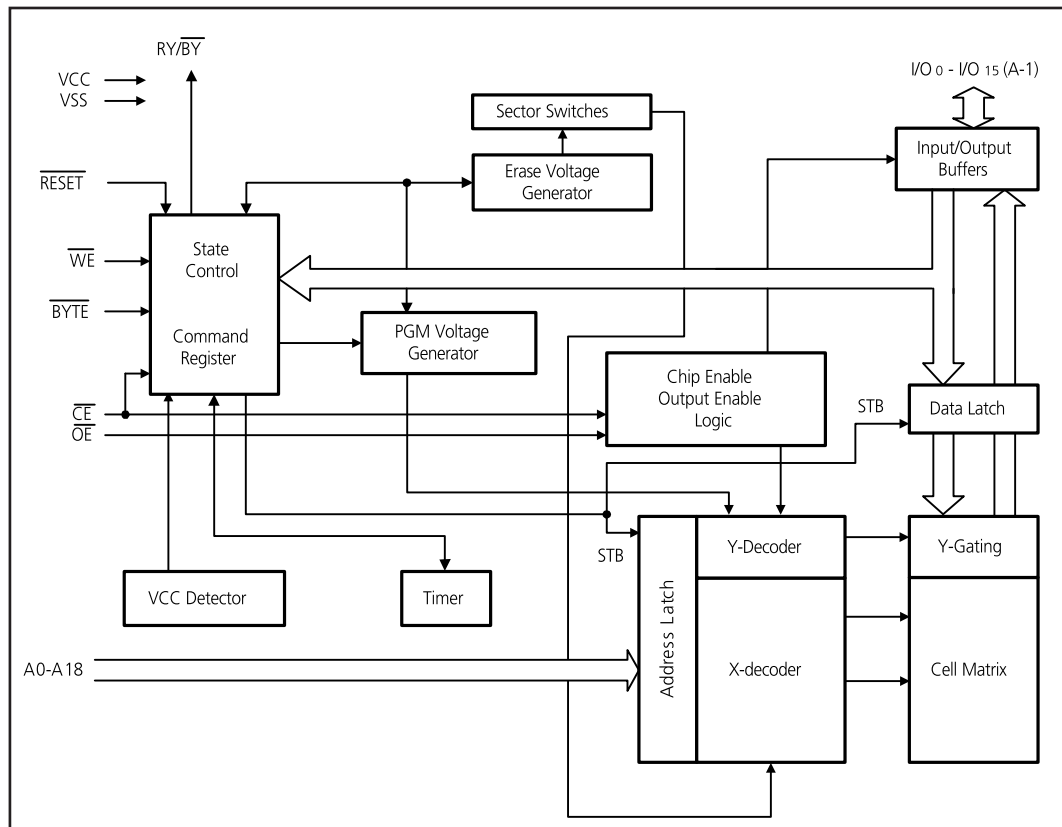

A29800UV-70 Block Diagram

4. EEPROM : S524C20D21(HT24LC02)

This stores the information related to setup of DVD menus. This can read and write the optional information such as OSD, voice, language option after function for subtitle etc, the aspect or method of TV display, video option like display function and audio, screen saver, parental function through the I²C transmission method.

Description

The S524C20D21 serial EEPROM has a 2,048-bit (256 byte) capacity, supporting the standard I²C™-bus serial interface. It is fabricated using Samsung most advanced CMOS technology. One of its major feature is a hardware-based write protection circuit for the entire memory area. Hardware-based write protection is controlled by the state of the write-protect (WP) pin. Using one-page write mode, you can load up to 16 bytes of data into the EEPROM in a single write operation. Another significant feature of the S524C20D21 is its support for fast mode and standard mode.

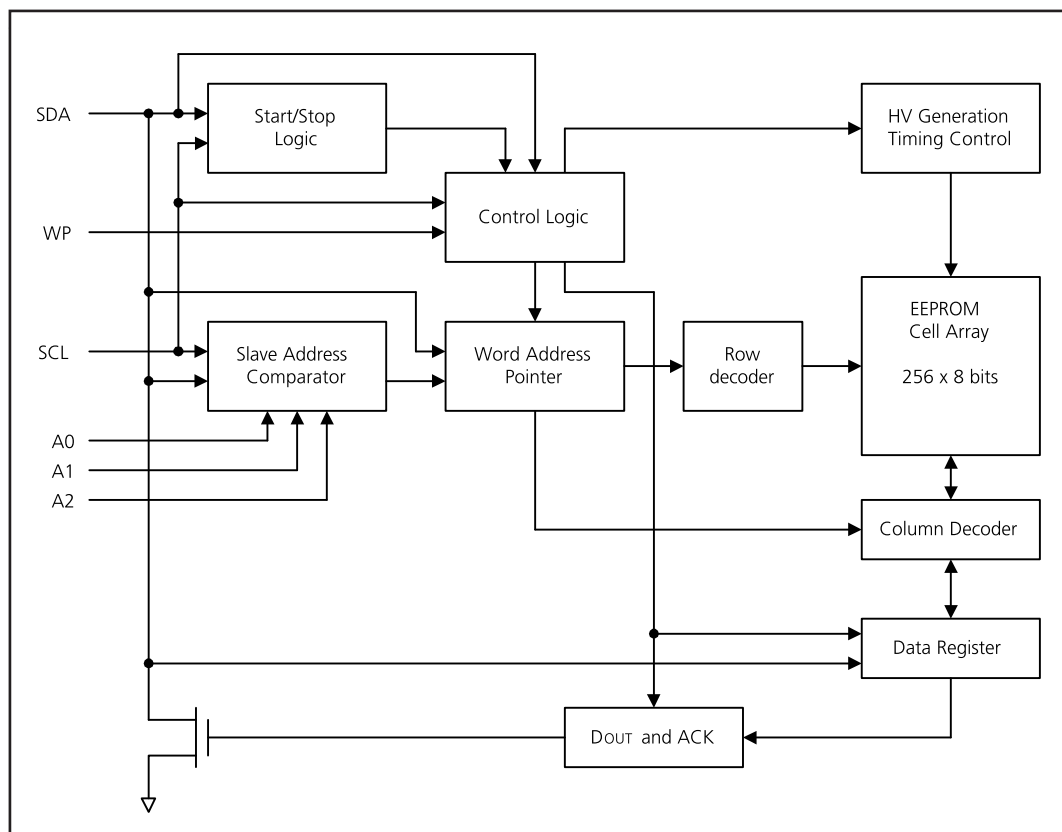

S524C20D21 Block Diagram

5. SDRAM : HY57V641620HGT-H(HY57V641620HGT-55)

This sends and receives data with MPEG decoder and performs the video signal processing. Every video signal output from DVD player is once stored in SDRAM and then encoded in MPEG decoder and finally output into the analog signal. SDRAM applied to DVD module has the capacity of 64MBit(1048576 x 16bit x 4Bank), sends and receives data with MPEG decoder by 16 bit.

Description

The Hynix HY57V641620HGT-H is a 67,108,864-bit CMOS Synchronous DRAM, ideally suited for the main memory applications which require large memory density and high bandwidth. HY57V641620HGT-H is organized as 4banks of 1,048,576x16.

HY57V641620HGT-H is offering fully synchronous operation referenced to a positive edge of the clock. All inputs and outputs are synchro-nized with the rising edge of the clock input. The data paths are internally pipelined to achieve very high bandwidth. All input and output voltage levels are compatible with LVTTTL.

Programmable options include the length of pipeline (Read latency of 2 or 3), the number of consecutive read or write cycles initiated by a single control command (Burst length of 1,2,4,8 or Full page), and the burst count sequence(sequential or interleave). A burst of read or write cycles in progress can be terminated by a burst terminate command or can be interrupted and replaced by a new burst read or write command on any cycle. (This pipelined design is not restricted by a `2N` rule.)

CIRCUIT OPERATIONAL DESCRIPTION

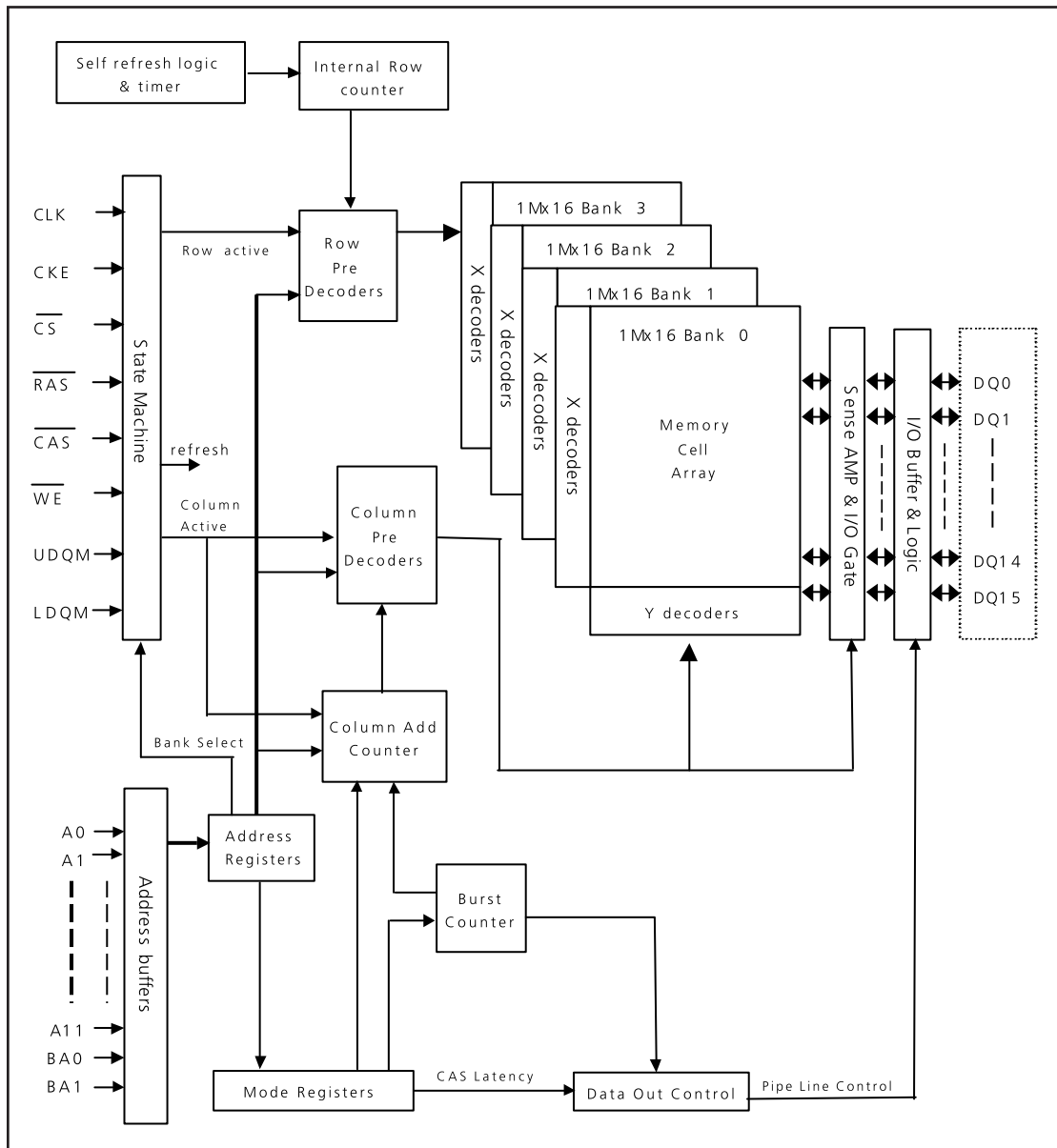

HY57V641620HGT-H Block Diagram

CIRCUIT OPERATIONAL DESCRIPTION

6. DAC : DA1132

DA1132 is a high performance stereo digital to analog converter for consumer electronics applications such as, VCD/DVD player, DVD-ROM driver, MPEG-2 card, set-top box, and home theaters etc. It accepts input word length of 16, 18, 20, and 24bits and supports audio sampling frequency from 16KHz to 96KHz. In addition. DA1132 provides a range of control features either via 3-wire serial interface ports or hardware pins.

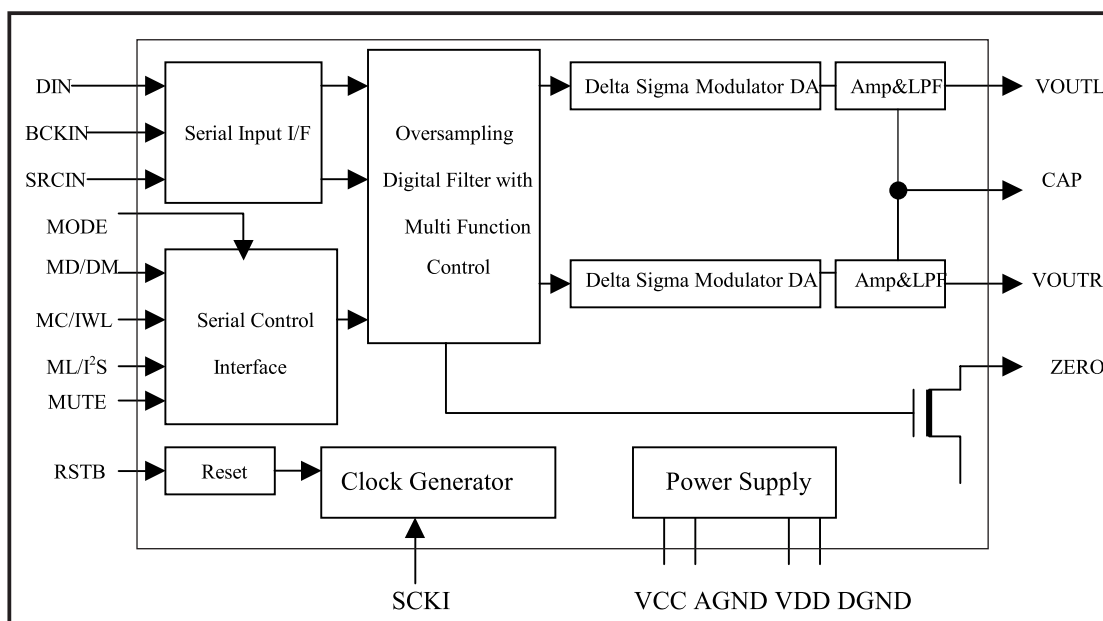

DA1132 Block Diagram

VOLTAGE CHARTS

Power board output voltage

J1

Pin number	1	2	3	4	5	6	7	8	9
Output voltage	GND	S5V	3.3V	D5V	GND	A5V	GND	+12V	-12V

J2

Pin number	1	2	3	4	5	6
Output voltage	SW	F-	F+	GND	-24V	STB5V

Decode board input voltage

CN1

Pin number	1	2	3	4	5	6	7	8	9
Output voltage	GND	S5V	3.3V	D5V	GND	A5V	GND	+12V	-12V

CIRCUIT DIAGRAM

1. POWER SUPPLY SCHEMATIC DIAGRAM

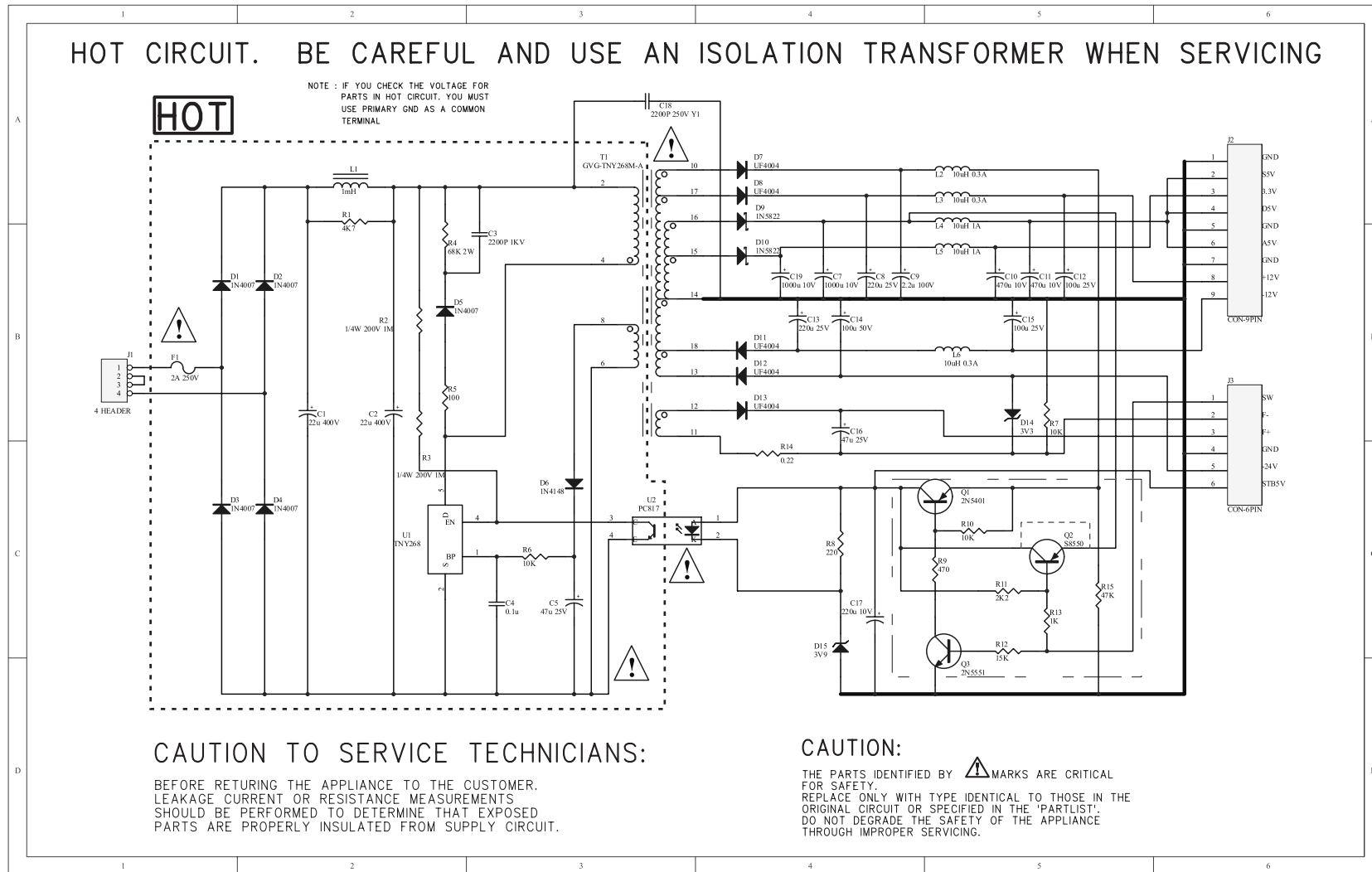

2. DECODE BOARD SCHEMATIC DIAGRAM

1) Vibratto-II

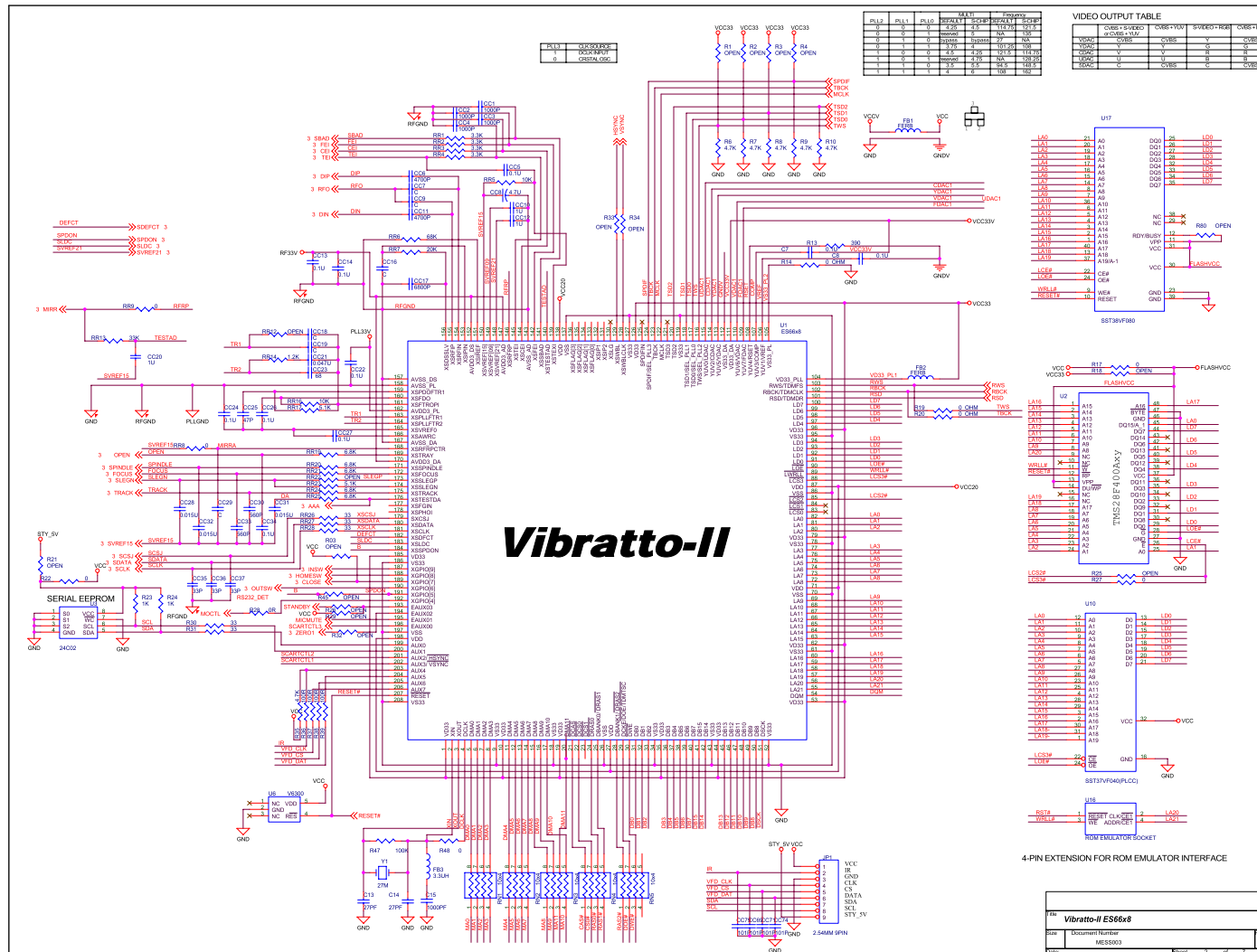

2) ES6603 and motor drivers

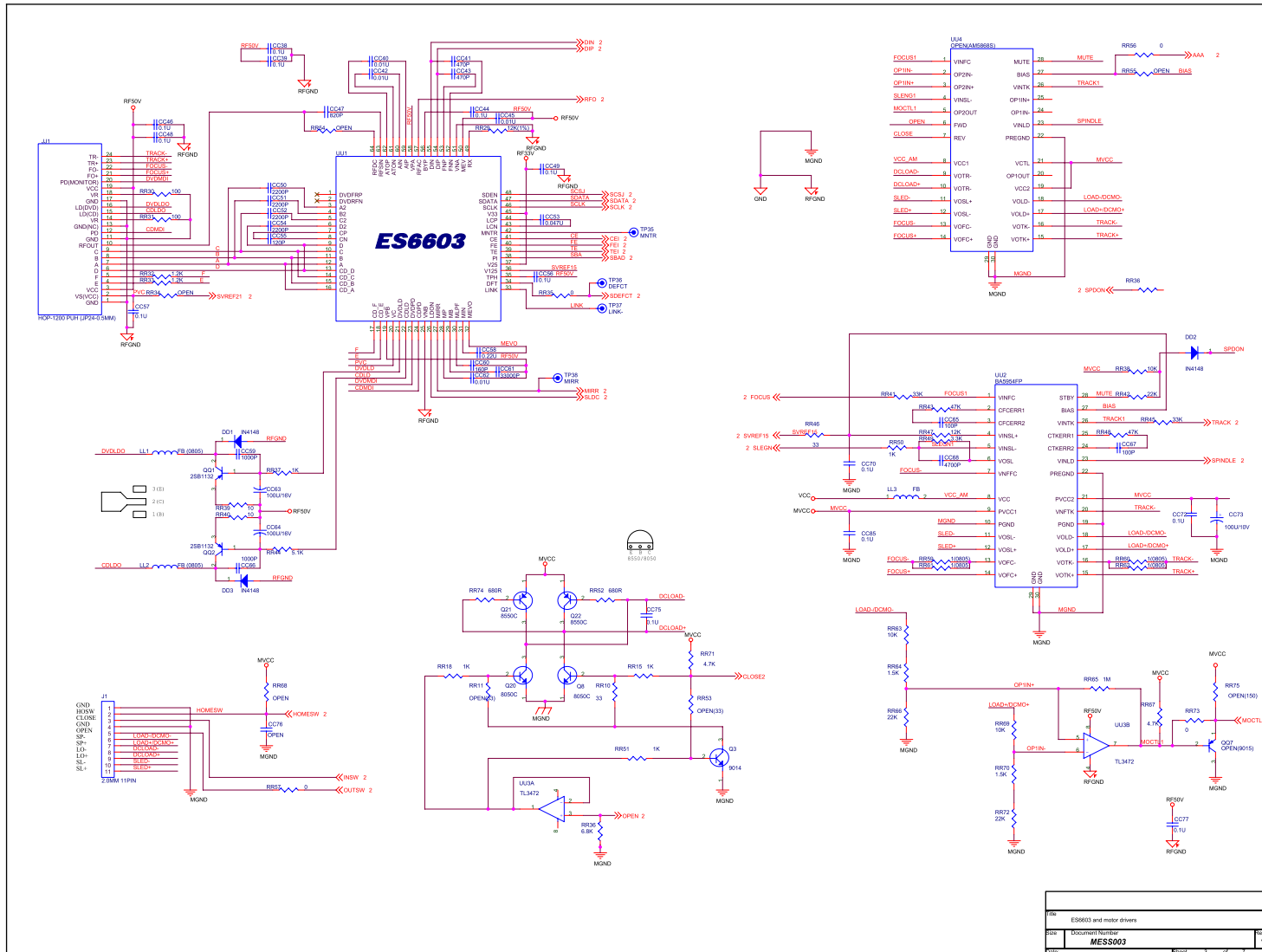

3) Audio and Power

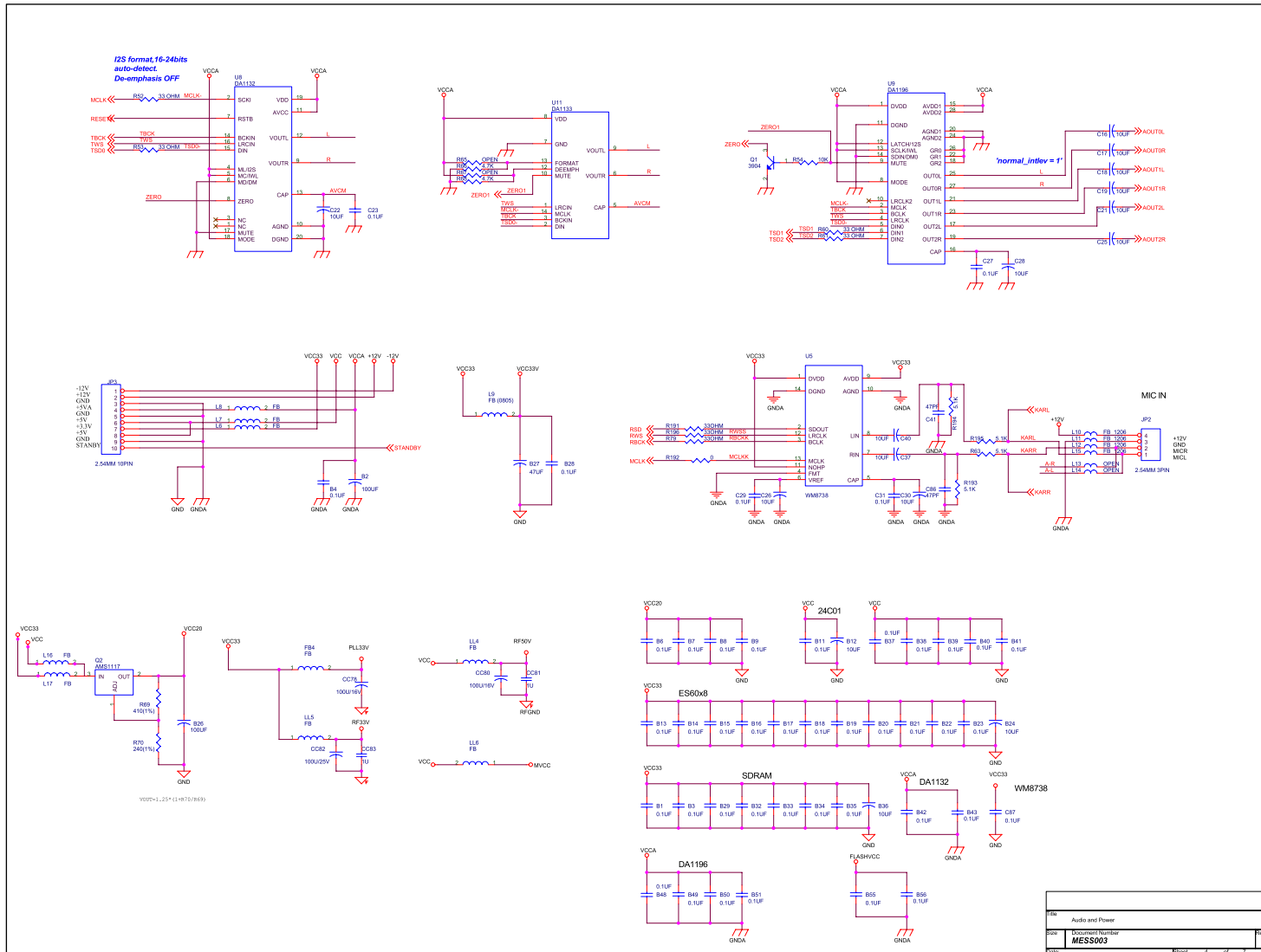

Rev	Audio and Power	Rev
Doc	Document Number	MESS003
Date		Rev A1

4) Audio filter and output

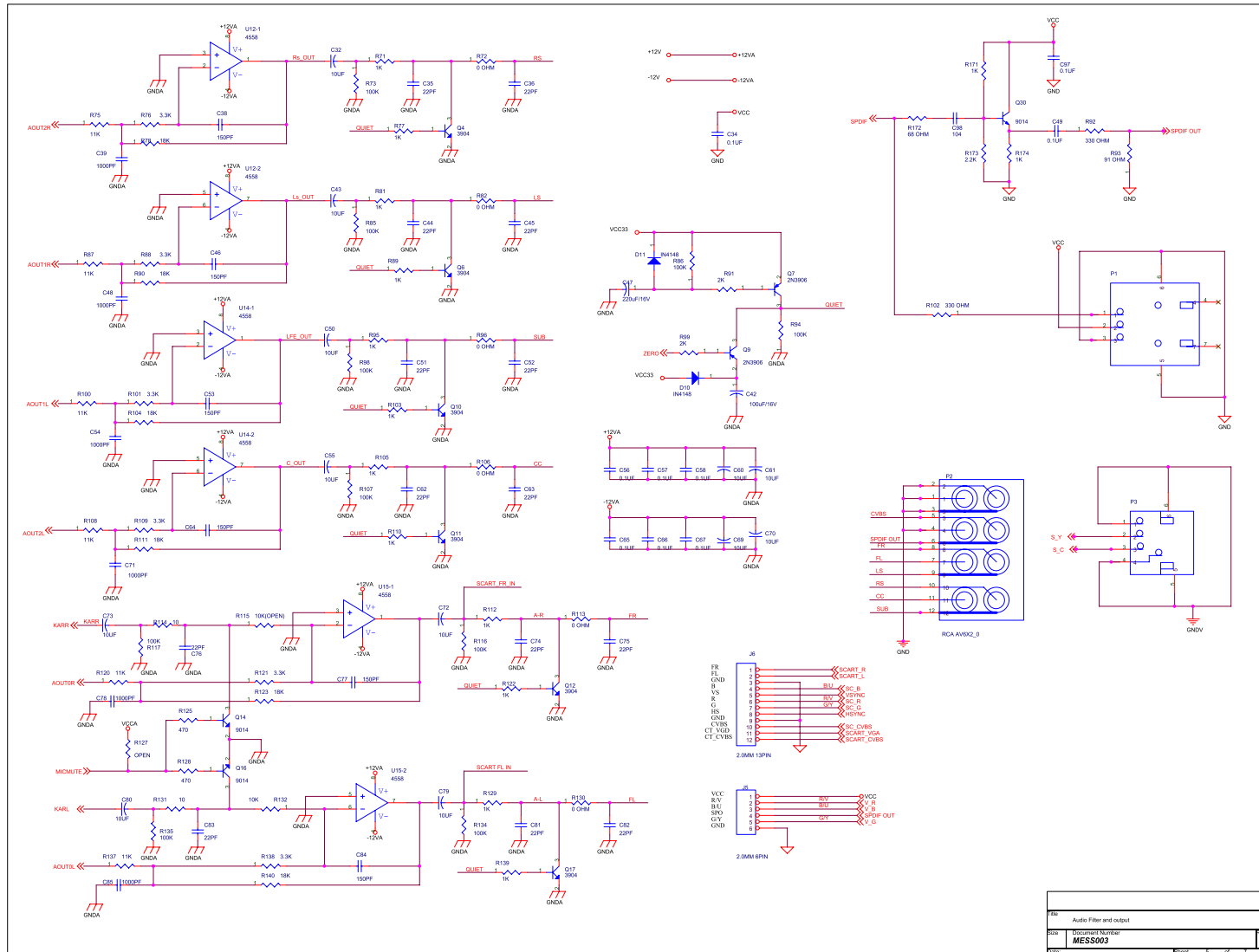

File	Audio Filter and output	Rev	A1
Size	Document Number		
	MESS003		
Sheet	5	of	7

5) Flash & SDRAM

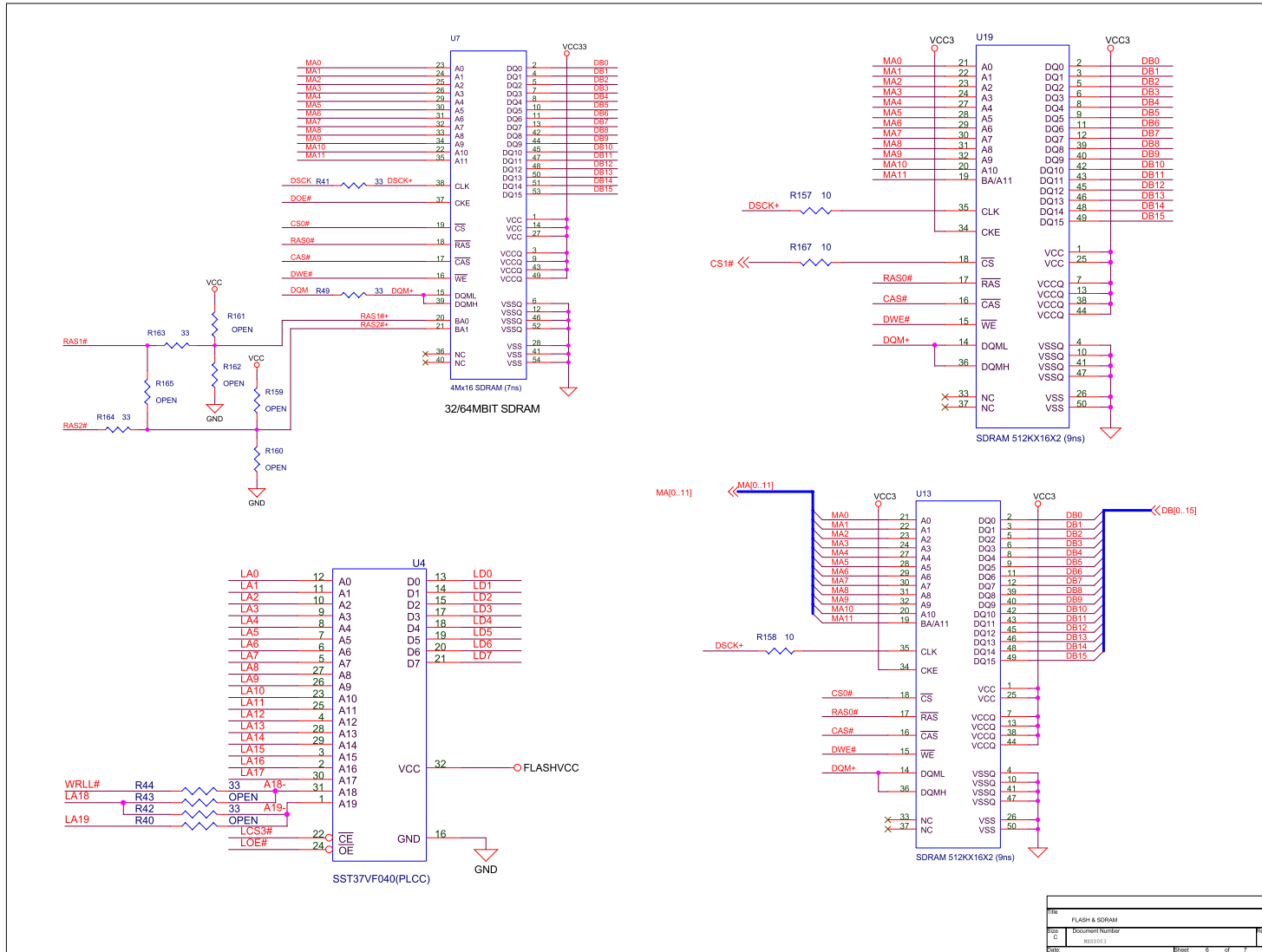

6) SCART

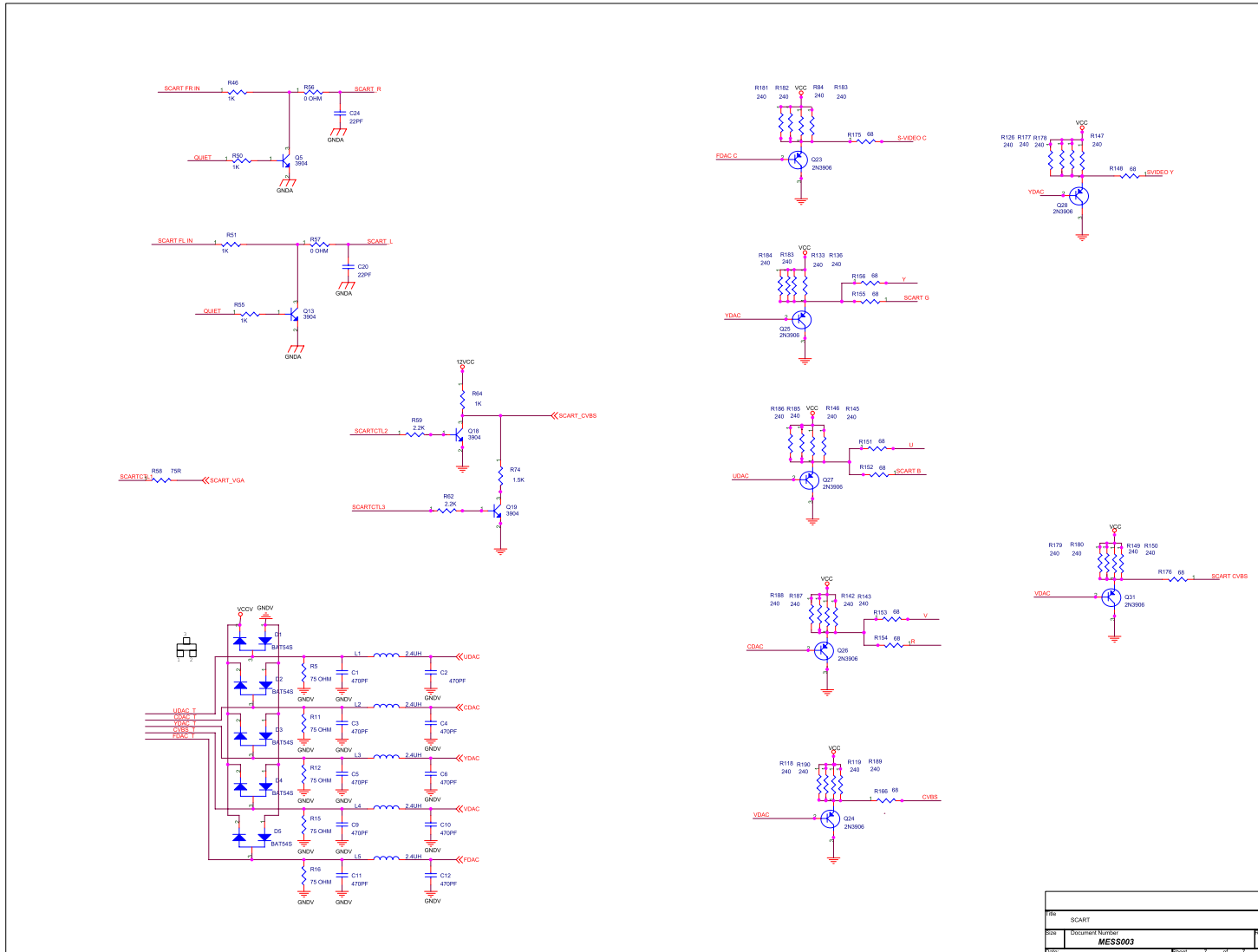

3. CONTROL BOARD SCHEMATIC DIAGRAM

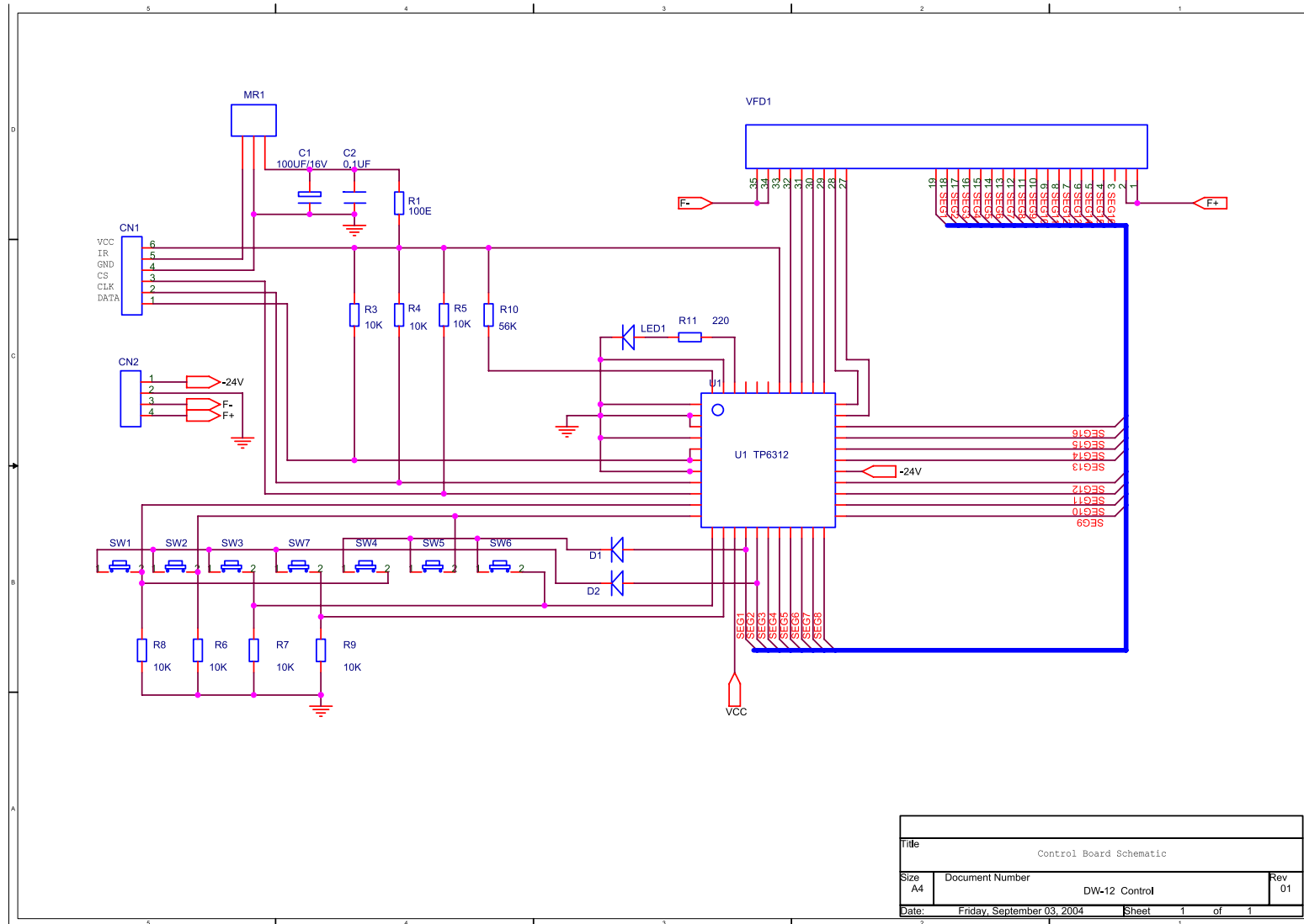

Title		
Control Board Schematic		
Size	Document Number	Rev
A4	DW-12 Control	01
Date:	Friday, September 03, 2004	Sheet 1 of 1

4. MICROPHONE BOARD SCHEMATIC DIAGRAM

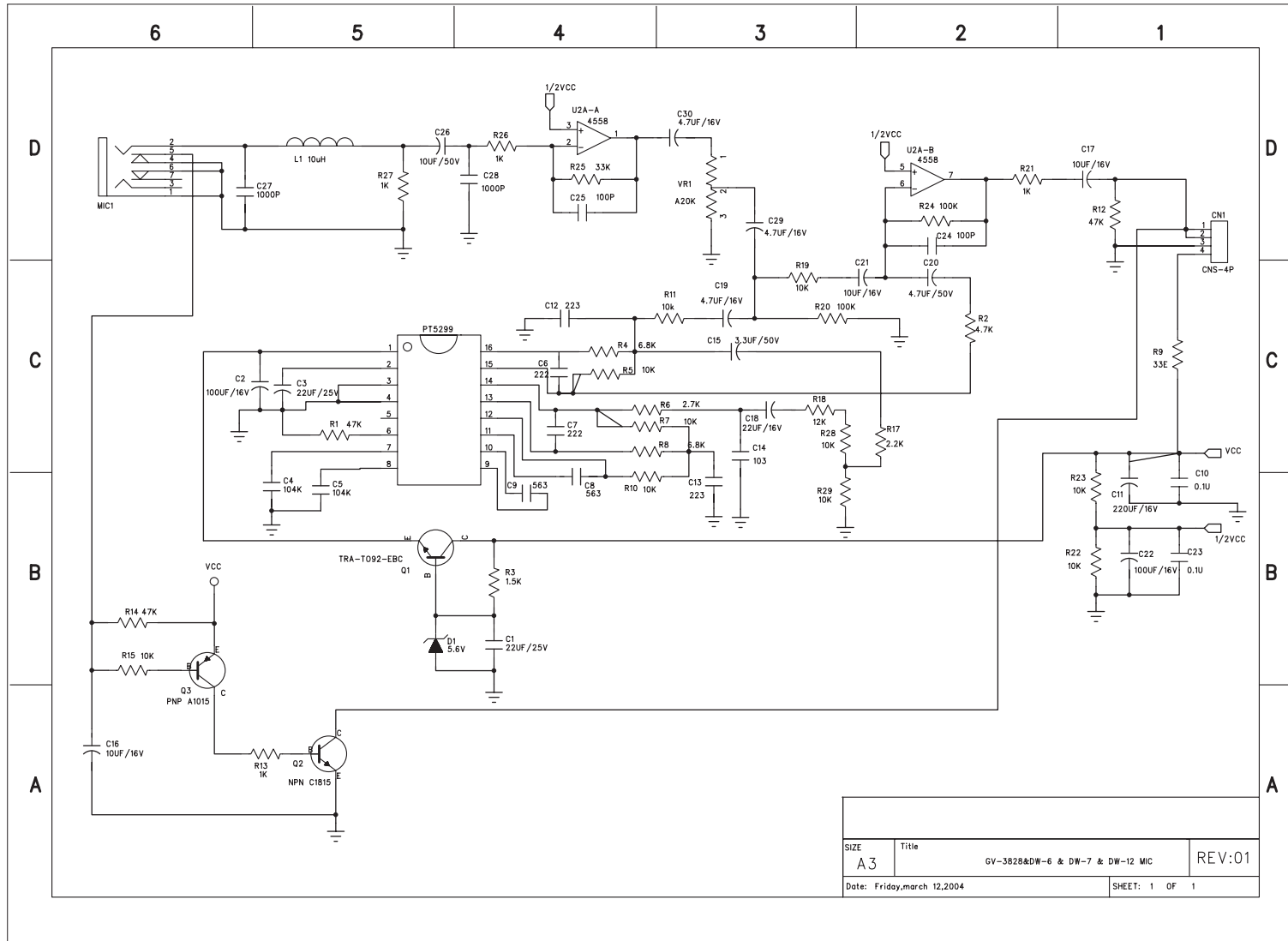

PCB CIRCUIT BOARD

1. POWER SUPPLY BOARD

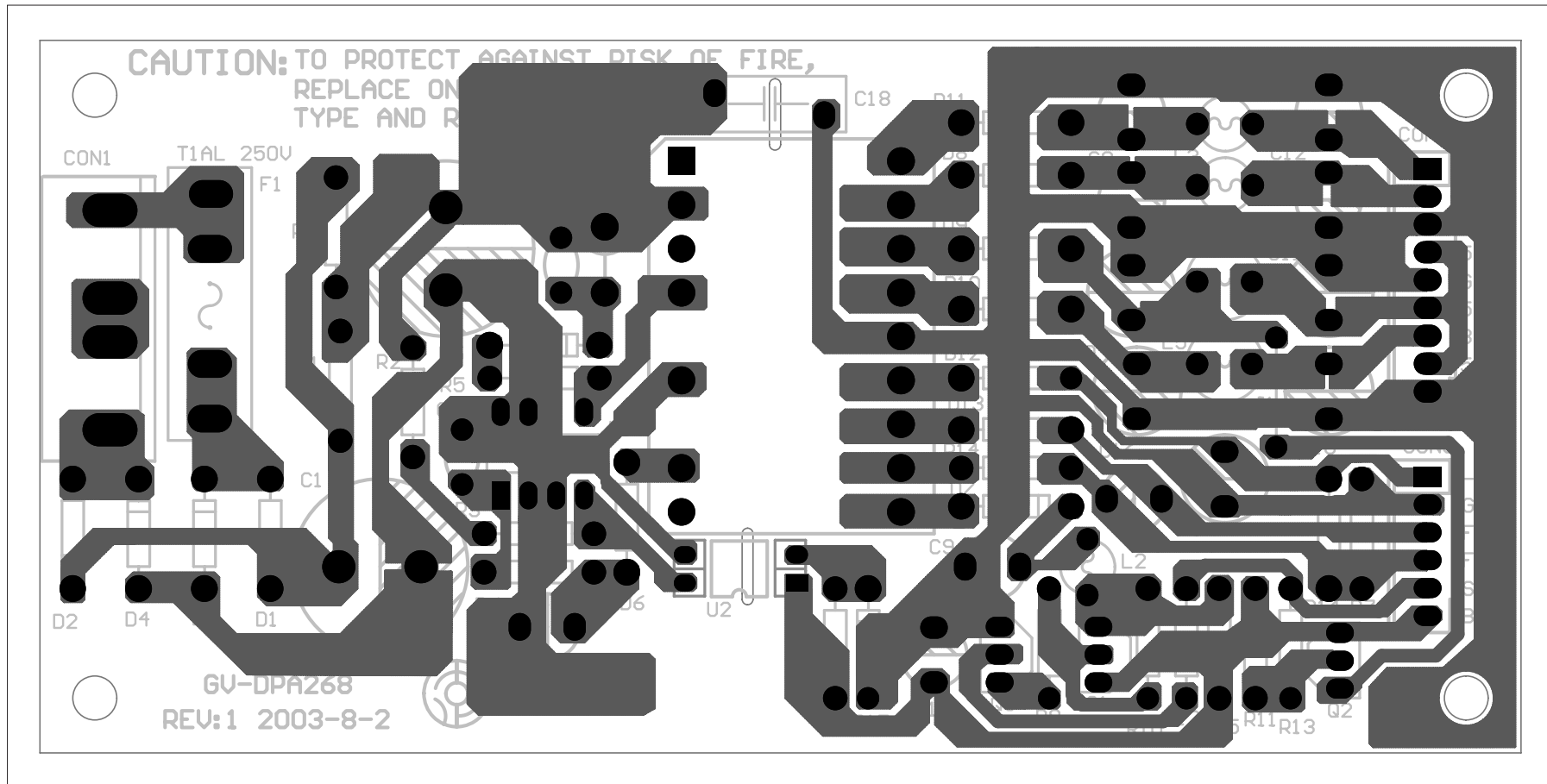

2. DECODE BOARD

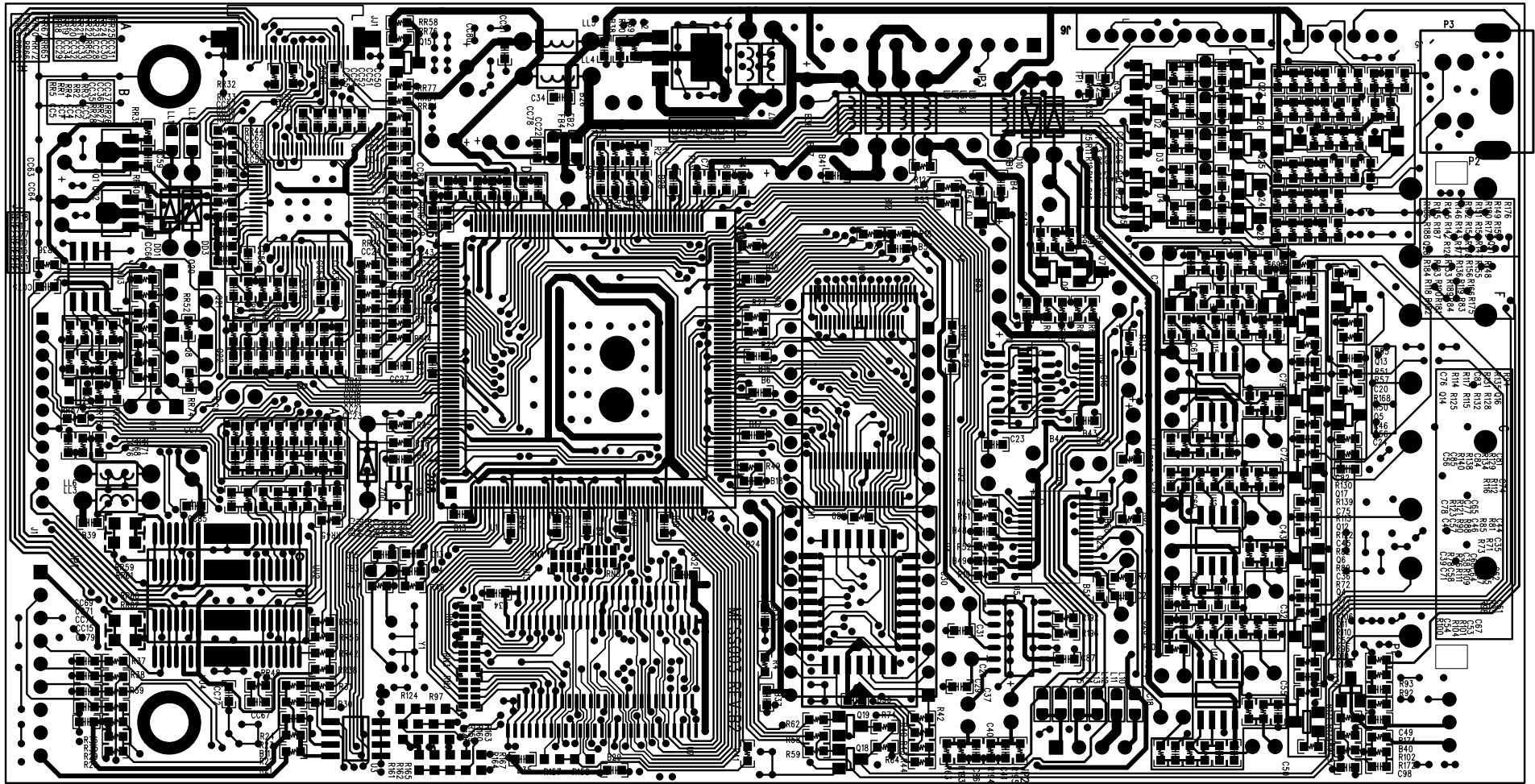

3. CONTROL BOARD

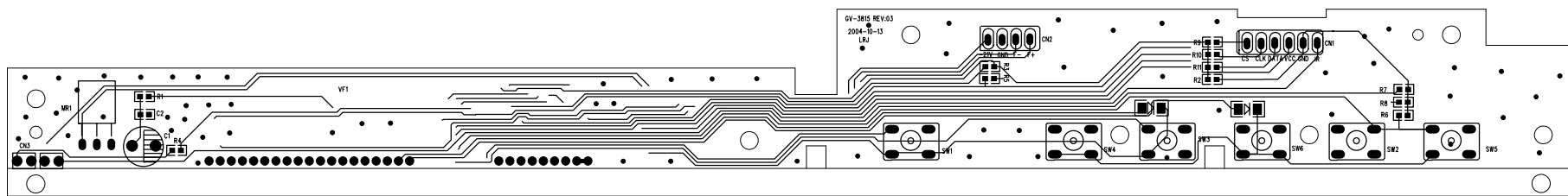

4. MICROPHONE BOARD

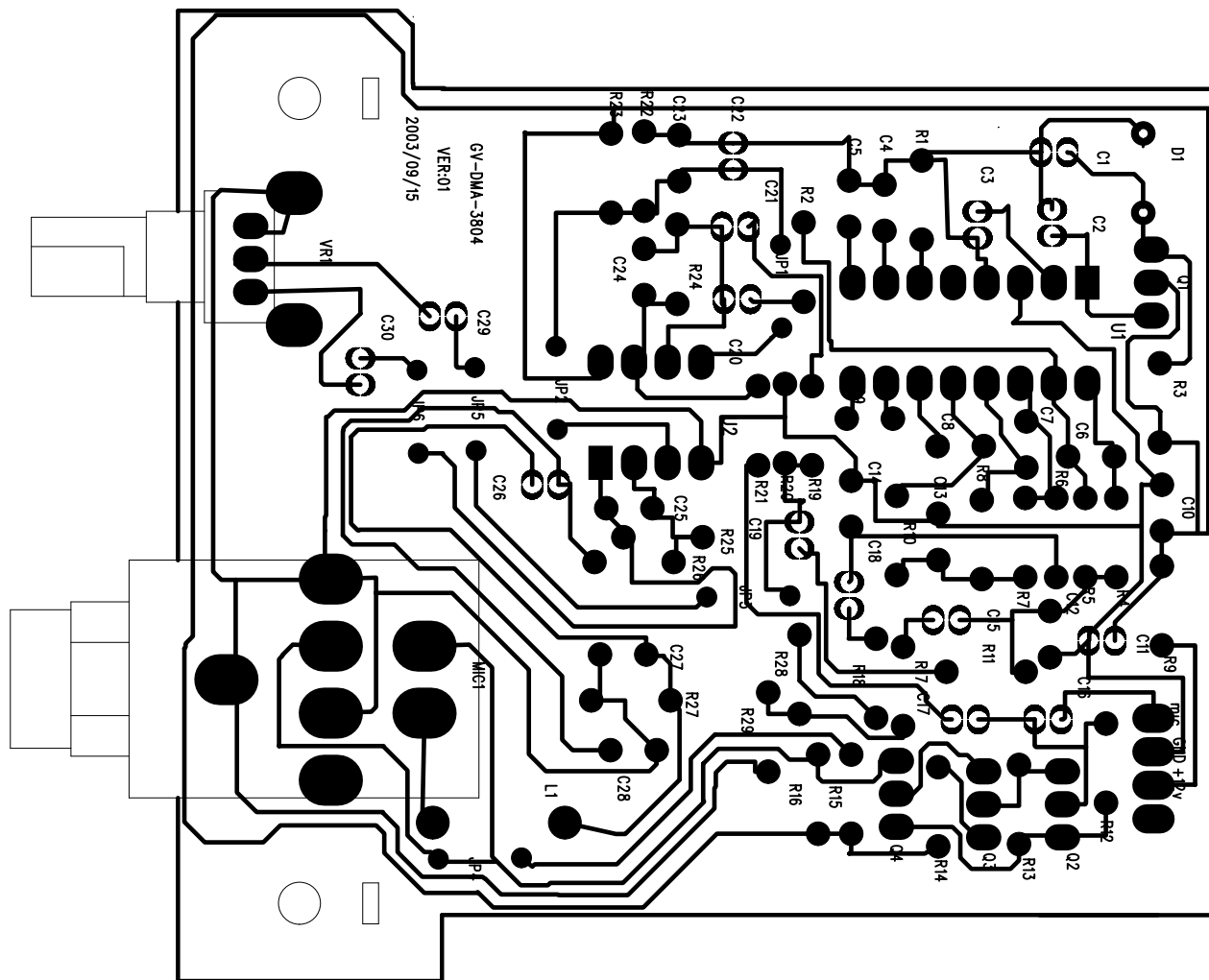

INSTRUMENT DISASSEMBLY

Perform all disassembly procedures in the order presented.
When reassembling, use the reverse procedure.
Make sure that all leads/ wiring are routed correctly when reassembling.

A. TOP COVER REMOVAL

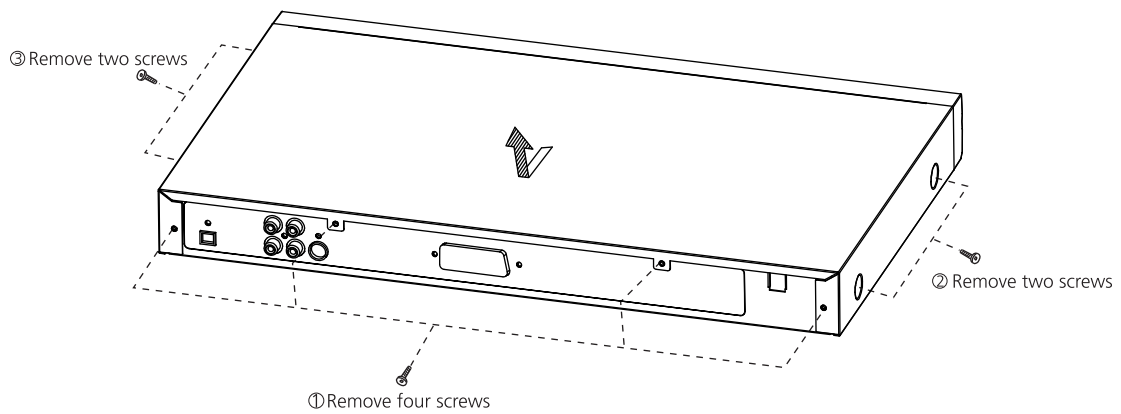
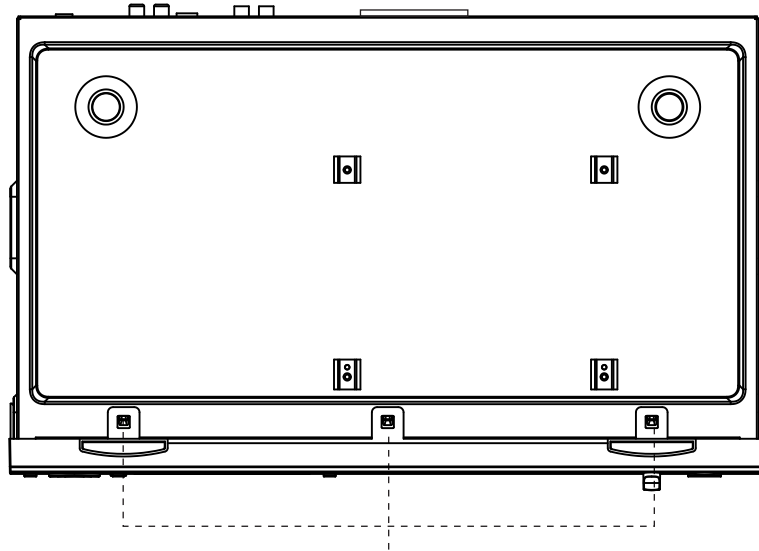

FIG. 1

B. FRONT PANEL DISASSEMBLY



① Remove three hooks.

② Remove three hooks,
Simultaneously, remove panel.

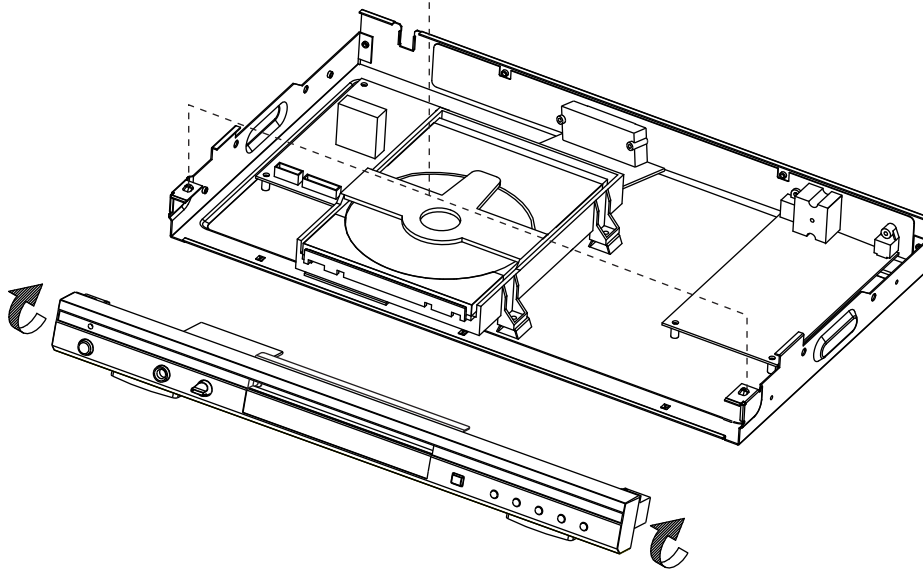

FIG. 2

C. DECODE BOARD DISASSEMBLY

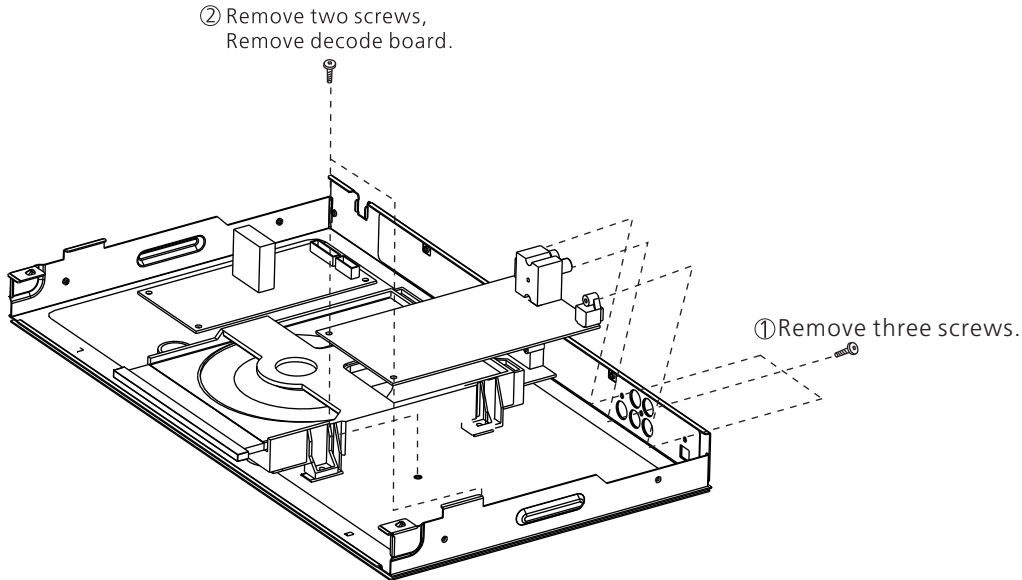

FIG. 3

D. POWER SUPPLY BOARD DISASSEMBLY

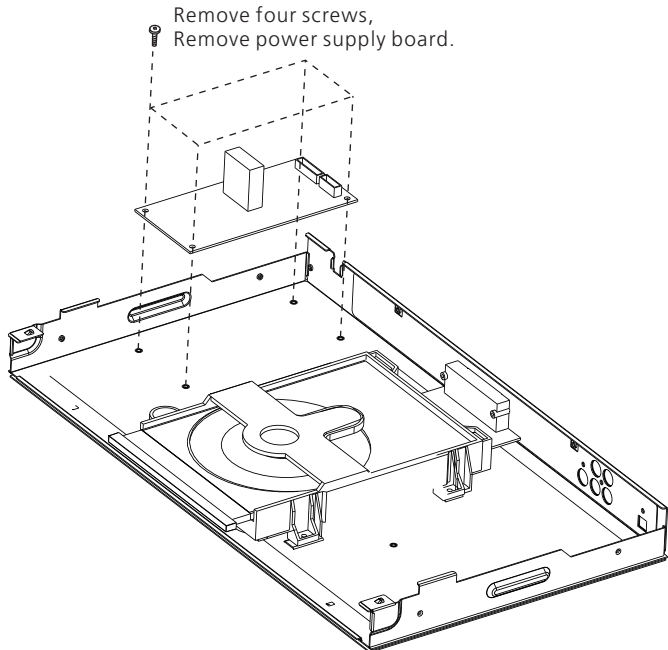

FIG. 4

E. YUV OUTPUT BOARD DISASSEMBLY

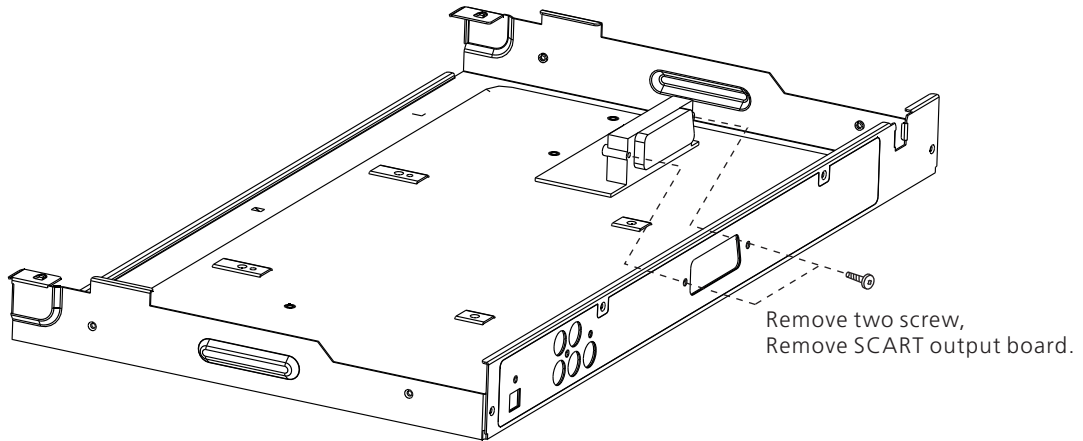

FIG. 5

F. DVD LOADER DISASSEMBLY

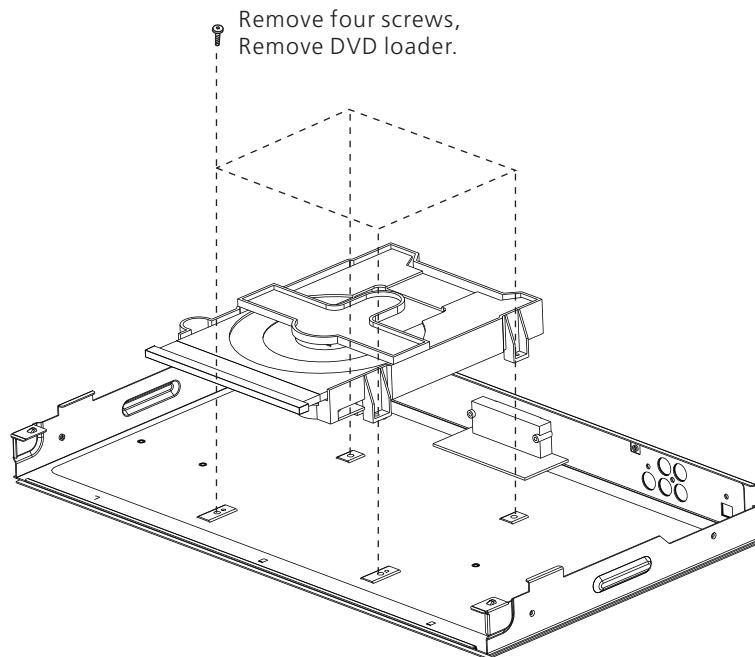

FIG. 6

PARTSLIST

Level	Part code	Part name	Specification	Unit	Dosage	Location
0	6020463	DVD unit	DV-700S 2CH ESS6698	PCS	1	
1	0900001	Battery	7# English	PCS	2	
2	1100001	Ferrite core	outside Φ 28mm inside Φ 16mm H:7.5mm	PCS	1	Outside machining
3	1270001	Tie	black 120mm	PCS	1	For power cord
4	1270002	Tie	nylon 80mm	PCS	3	
5	5450048	PVC sheet	146x64x0.5mmPVC	PCS	1	Under power pcb
6	1310071	Connector	2.54 9P*320mm red-white	PCS	1	
7	1350041	Power Cord	2 pins VDE(Xie kang)(outside 1.5m,inside 350*15 with ferrite core)	PCS	1	
8	1360001	AV Cable	Audio 4 pin ,white red , L:1.5m	PCS	1	
9	1360002	AV Cable	Video 2 pin , yellow , L:1.5m	PCS	1	
10	1640046	DVD Loader	Shinwa slim SHD-2503CWJ-03 HOP-1200W (with bus wire(reversed)0.5mm/24P 200mm)	PCS	1	
11	2500001	Handle	plastic white for gift box	PCS	1	
12	3000105	Top Cover	3816(Silver)with DAEWOO stamp	PCS	1	
13	3010087	Bottom cover	3816-ESS6628(Shinwa)-268	PCS	1	
14	5450062	PVC sheet	DV-700S(Poland) on Rear panel	PCS	1	Rear panel
15	2010056	CD Door	GV-2802 (silver 3815)	PCS	1	
16	3500058	Screw	BM3*6	PCS	6	power pcb 4, mpeg pcb 2
17	3500084	Screw	BB3*8 Φ 5	PCS	5	Audio optical jack 3 SCART2
18	5740012	SCART PCB assy	ESS SCART-02	PCS	1	
19	1000222	Bare PCB	SGVG002 REV:B1 SCART pcb	PCS	1	
20	1150010	Scart Jack	XH-21pin SCART	PCS	1	J1
21	1310349	Connector	2.0 10P*220mm red-white 4~5 crossed with ferrite core	PCS	1	CN1

22	3500007	Screw	BTPW3*6	PCS	8	both side of Top cover 8
23	3500004	Screw	BTPW3*8	PCS	4	loader
24	4050408	Gift Box	DV-700S (Poland)	PCS	1	
25	4500060	Pad Foam	3816 left(new)	PCS	1	
26	4500061	Pad Foam	3816 right(new)	PCS	1	
27	4600004	Poly bag for set	480*580mm	PCS	1	
28	4600005	PE bag for manual	04*230*370mm	PCS	1	
29	4600006	PE bag for remocon	04*80*260mm	PCS	1	
30	5000046	Masking Tape	10mm*15mm	PCS	1	For bus wire (Mpeg board)
31	5000047	Masking Tape	50mm*10mm	PCS	1	For bus wire(bottom cover)
32	5440073	Cushion	3816 Front leg 46.6*6.6*8mm Rigidity:64	PCS	2	
33	5440074	Cushion	3816 Behind Φ 15.5mm Thickness:3mm Rigidity:64	PCS	2	
34	5450002	PVC sheet	90x70x0.5mmPVC	PCS	2	under topcover over power trans,and under Mic pcb
35	5750037	Power pcb	GV-DPA268-13(NO STANDBY)	PCS	1	
36	0000024	R carbon film	1/4W 150E \pm 5%	PCS	1	R8
37	0000032	R carbon film	1/4W 4.7K \pm 5%	PCS	1	R1
38	0000034	R carbon film	1/4W 10K \pm 5%	PCS	2	R6.R7
39	0000045	R carbon film	1/4W 1M \pm 5%	PCS	2	R2.R3
40	0000063	R carbon film	2W 68K \pm 5%	PCS	1	R4
41	0000068	R carbon film	1/4W 100E \pm 5%	PCS	1	R5
42	0072001	R Fuse	1/4W 0.22E \pm 5%	PCS	1	R14
43	0110002	C Cera AC	250V2200PF \pm 20% Y1	PCS	1	C18
44	0150008	C Cera	104 50V \pm 10% 5	PCS	1	C4
45	0150011	C Cera	1KV4700PF \pm 10% Y5P	PCS	1	C3

46	0190030	C Electro	16V 100UF ±20% D5	PCS	2	C12.C15
47	0190088	C Electro	16V 220UF ±20% D6 105°C	PCS	2	C8.C13
48	0190025	C Electro	10V 470UF ±20% D8	PCS	2	C10.C11
49	0190089	C Electro	10V 1000UF ±20% D8 105°C	PCS	2	C7.C19
50	0190026	C Electro	10V 220UF ±20%	PCS	1	C17
51	0190087	C Electro	50V 100UF ±20% D8	PCS	1	C14
52	0190040	C Electro	25V 47UF ±20% D5	PCS	2	C5.C16
53	0190125	C Electro	400V 22UF ±20% D16x22	PCS	2	C1.C2
54	0250015	Coil	1A 10uH	PCS	2	L4.L5
55	0250016	Bead core	0.2A3.3uH	PCS	2	L3.L6
56	0250041	Coil	1mH 200mA	PCS	1	L1
57	0300010	Power Trans	GVG-TNY268M-A	PCS	1	T1
58	0320003	Diode	UF4004	PCS	4	D8.D11.D12.D13
59	0320004	Diode	1N4148	PCS	1	D6
60	0320005	Diode	1N4007	PCS	5	D1~5
61	0320010	Diode	1N5817	PCS	1	D10
62	0380004	Diode Schottky	SR360 3A60V	PCS	1	D9
63	0330007	Diode Zener	3.9V 1/2W	PCS	1	D15
64	0330016	Diode Zener	3.3V 1/2W	PCS	1	D14
65	0510175	IC	TNY268P	PCS	1	U1
66	0640001	IC photo coupler	PC817B	PCS	1	U2
67	1000115	Bare PCB	GV-DPATNY268-1 power pcb	PCS	1	
68	1150059	Connector Jack	XH-2Pin 3.96mm	PCS	1	CON1
69	1150003	Connector Jack	XH-4Pin 2.54mm	PCS	1	J3
70	1150043	Connector Jack	XH-9Pin 2.54mm	PCS	1	J2
71	1260006	Jumper	Pin Distance:10mm	PCS	2	J1,CON1

72	1400009	Tube	Φ 1.5mm L:10mm	PCS	2	D10
73	1450006	Fuse	1A 250V UL	PCS	1	F1
74	1460002	Fuse case	Metal	PCS	2	F1
75	3670001	Washer	Φ 3.2 for Grounding	PCS	1	
76	1260002	Jumper	Pin Distance:5mm	PCS	1	Q2
77	5780220	Front panel assy	DV-700S silver	PCS	1	
78	2000228	Front panel	DV-700S (silver)	PCS	1	
79	2300125	Mirror	For VFD 700S(Silver)	PCS	1	
80	2100174	Standby knob	3815STANDBY key (silver)	PCS	1	
81	2100172	Open knob	3815 open key (silver)	PCS	1	
82	2100173	Play knob	3815 play key (silver)	PCS	1	
83	2200041	Vol knob	3815 volume key(silver)	PCS	1	
84	3670002	Washer	Thickness:0.5mm Φ3mm	PCS	2	
85	3500005	Screw	BB3*8	PCS	15	Control pcb 7,metal base4,switch2, Mic pcb2
86	2300081	Mirror	3815 left side	PCS	1	
87	5710062	Mic PCB assy	GV-DMA3804-04	PCS	1	
88	0000005	R carbon film	1/6W 10K ±5%	PCS	8	R5,R7,R10,R19,R22,R23,R28,R29
89	0000002	R carbon film	1/6W 1K ±5%	PCS	3	R21,R26,R27
90	0000015	R carbon film	1/6W 15K ±5%	PCS	1	R11
91	0000020	R carbon film	1/6W 100K ±5%	PCS	2	R20,R24
92	0000004	R carbon film	1/6W 4.7K ±5%	PCS	1	R2
93	0000018	R carbon film	1/6W 47K ±5%	PCS	1	R12
94	0000013	R carbon film	1/6W 1.5K ±5%	PCS	1	R3
95	0100011	Pot	R0903NE-F20-C20K 3 pins	PCS	1	VR1
96	1150027	Mic Jack	Silver 7 pin	PCS	1	MIC1

97	0510129	IC	F4558N (DIP)	PCS	1	U2
98	0510058	IC	TP5299P	PCS	1	U1
99	0250006	Bead core	RH3.5*4.7*0.8	PCS	1	L1
100	0190008	C Electro	50V 4.7UF ±20% D5	PCS	4	C20,C29,C30,C19
101	0190039	C Electro	25V 22UF ±20% D5	PCS	3	C3,C1,C18
102	0190031	C Electro	50V 3.3UF ±20%	PCS	1	C15
103	0190030	C Electro	16V 100UF ±20% D5	PCS	3	C2,C11,C22
104	0150008	C Cera	104 50V ±10% 5	PCS	4	C5,C10,C4,C23
105	0150007	C Cera	101 50V ±10%	PCS	2	C24,C25
106	0150001	C Cera	563 50V ±10%	PCS	2	C8,C9
107	0150003	C Cera	102 50V ±10%	PCS	2	C28,C27
108	0150014	C Cera	222 50V ±10%	PCS	2	C6,C7
109	0150015	C Cera	223 50V ±10%	PCS	2	C12,C13
110	0150013	C Cera	103 50V ±10%	PCS	1	C14
111	1000120	Bare PCB	GV-DMA-3804 MIC pcb	PCS	1	
112	1310095	Connector	2.54 4P/3P*650mm pins with shield	PCS	1	For 3815 front panel
113	1100003	Ferrite Core	outside Φ 16mm inside Φ 12mm H:8mm	PCS	1	
114	0190012	C Electro	50V 10UF ±20%	PCS	4	C16,C17,C21,C26
115	3900013	Metal base	9000 Mic pcb base	PCS	2	
116	0000153	R carbon film	1/6W 39K ±5%	PCS	1	R25
117	0450013	TR	C1815 β =70~700	PCS	1	Q1
118	3500002	Screw	BTV3*6	PCS	2	
119	0000113	R carbon film	1/6W 33K ±5%	PCS	1	R1
120	0000115	R carbon film	1/6W 330E ±5%	PCS	1	R9
121	0330001	Diode Zener	5.6V 1/2W	PCS	1	D1
122	1260010	Jumper	Pin Distance:18mm	PCS	1	JM

123	0000062	R carbon film	1/6W 6.8K ±5%	PCS	2	R4,R8
124	0000072	R carbon film	1/6W 27k ±5%	PCS	1	R6
125	1260003	Jumper	Pin Distance:6mm	PCS	6	JP1~JP6
126	0000006	R carbon film	1/6W 12K ±5%	PCS	1	R18
127	0000125	R carbon film	1/8W 2.2K ±5%	PCS	1	R17
128	5730124	Control pcb assy	GV-DCA3815-03 STB	PCS	1	
129	0050028	R Chip	1/16w 10K ±5% 0603	PCS	8	R2,R5~R11
130	0050007	R Chip	1/16w100E ±5% 0603	PCS	1	R1
131	0200036	R Chip	104 50V ±10% 0603	PCS	1	C2
132	0190103	C Electro	16V 100UF ±20% D6*5	PCS	1	C1
133	0390001	Diode Chip	1N4148	PCS	2	D1,D2
134	0510166	IC	D16312	PCS	1	U1
135	0710030	VFD	Hua Lian HL-D331C	PCS	1	VFD1
136	0800001	Tac-switch	6*6*5	PCS	7	SW1~SW7
137	1000162	Bare PCB	GV-3815-A control pcb	PCS	1	
138	1310263	Connector	2.54 6P*220mm red-white crossed	PCS	1	CN1
139	1310005	Connector	2.54 4P*500mm red-white	PCS	1	CN2
140	1500003	Receiver	PIC-317LM	PCS	1	REM1
141	1500005	Receiver	Remocon receiver FLIRM1030-6	PCS	1	REM1
142	1500011	Receiver	Remocon receiver PIC-331LM	PCS	1	REM1
143	5440014	Cushion	10x10x3mm EVI	PCS	2	For VFD
144	5440091	Cushion	8x7x6mm rigidity:64	PCS	1	For remocon receiver
145	0050072	R Chip	1/16w 51K ±5% 0603	PCS	1	R3
146	0340001	LED	Red Φ3mm	PCS	1	
147	1100002	Ferrite core	outsideΦ22.5mm insideΦ13.8mm H:6.4mm	PCS	1	
148	1000160	Bare PCB	GV-3815 REV:02 STANDBY	PCS	1	

149	1310257	Connector	4P*150mm red-white	PCS	1	
150	0050013	R Chip	1/16w220E ±5% 0603	PCS	1	R4
151	3900076	Metal base	3816 Front panel base	PCS	1	
152	2300082	Mirror	3815 right side	PCS	1	
153	5800300	Final Mpeg board	DV-700S #2 ESS6698-8P-C-03 (5700189)	PCS	1	
154	5700189	Mpeg board	GV-DJAESS6698-8P-C-03(2.0)MIC	PCS	1	
155	0050001	R Chip	1/16w 0E ±5% 0603	PCS	21	RR8,RR9,R17,R22,R27,RR35,R48,R14, R19,R20,R28,R113,R130.R57.RR55. RR57 RR58,R97,RR23.R56,L13and L14 near JP2
156	0050002	R Chip	1/16w 10E ±5% 0603	PCS	6	RR40,RR39.R157.R158.R114.R131
157	0050004	R Chip	1/16w 33E ±5% 0603	PCS	12	RR26,RR27,RR28,R30,R31,R41,RR46,R4 9R163.R164.R52.R53
158	0050009	R Chip	1/16w150E ±5% 0603	PCS	1	RR75
159	0050006	R Chip	1/16w 75E ±5% 0603	PCS	6	R5,R11,R12,R15,R16.R58
160	0050007	R Chip	1/16w100E ±5% 0603	PCS	6	R36,R37,R38,R39,RR30,RR31
161	0050017	R Chip	1/16w330E ±5% 0603	PCS	2	R102.R92
162	0050019	R Chip	1/16w 1K ±5% 0603	PCS	16	R23,R24,RR37,R171.R51.R46.R55.R64, R74.R112.R122.R129.R139.R174.R50. R127
163	0050020	R Chip	1/16w 2K ±5% 0603	PCS	1	R91
164	0050021	R Chip	1/16w2.2K ±5% 0603	PCS	3	R173.R59.R62
165	0050101	R Chip	1/16w 56K ±5% 0603	PCS	2	RR41.RR45
166	0050031	R Chip	1/16w 15K ±5% 0603	PCS	1	RR50
167	0460013	TR Chip	9014 (SOT23)	PCS	1	Q30
168	0050023	R Chip	1/16w3.3K ±5% 0603	PCS	6	RR1,RR2,RR3,RR4,R121,R138
169	0050026	R Chip	1/16w4.7K ±5% 0603	PCS	8	R6,R7,R8,R9,R10,R35,RR67,R68

170	0050028	R Chip	1/16w 10K \pm 5% 0603	PCS	8	RR5,RR16,RR38,R54,RR63,RR69,R120. R137
171	0050057	R Chip	1/16w 75E \pm 1% 0603	PCS	1	R70
172	0050033	R Chip	1/16w 20K \pm 5% 0603	PCS	3	RR7,R123.R140
173	0050034	R Chip	1/16w 22K \pm 5% 0603	PCS	5	RR42,RR66,RR72,R115.R132
174	0050036	R Chip	1/16w100K \pm 5% 0603	PCS	7	R86,R94,R116,R134.R47.R117.R135
175	0050038	R Chip	1/16w390E \pm 5% 0603	PCS	1	R13
176	0050041	R Chip	1/16w 91E \pm 5% 0603	PCS	1	R93
177	0050042	R Chip	1/16w6.8K \pm 5% 0603	PCS	6	RR19,RR20,RR21,RR24,RR25,RR36
178	0050045	R Chip	1/16w 1M \pm 5% 0603	PCS	1	RR65
179	0050052	R Chip	1/16w 33K \pm 5% 0603	PCS	1	RR13
180	0050071	R Chip	1/16w 5.1K \pm 5% 0603	PCS	2	RR17,RR44
181	0050085	R Chip	1/16w 68E \pm 5% 0603	PCS	11	R172,R156.R155.R151.R152.R153. R154.R166.R148.R176.R175
182	0050097	R Chip	1/16w1.2K \pm 5% 0603	PCS	3	RR14,RR32,RR33
183	0050102	R Chip	1/16w 68K \pm 5% 0603	PCS	1	RR6
184	0050108	R Chip	1/16w 12K \pm 1% 0603	PCS	1	RR29
185	0060001	R Chip	1/16w10E*4 \pm 5% 0603	PCS	5	RN1,RN2,RN3,RN4,RN5
186	0190013	C Electro	16V 220UF \pm 20% D6	PCS	1	C47
187	0190008	C Electro	50V 4.7UF \pm 20% D5	PCS	1	CC8
188	0190033	C Electro	25V 10UF \pm 20% D5	PCS	16	B12,C16.C17.C22,B24,B25,B36,B44, B53,B54,C61,C70,C72,C79.C73.C80
189	0190022	C Electro	16V 47UF \pm 20% D5	PCS	1	B27
190	0190030	C Electro	16V 100UF \pm 20% D5	PCS	8	CC63,CC64,CC78,CC80,B2.B26,CC73, CC82
191	0200003	C Chip	22P 50V \pm 10% 0603	PCS	6	C74,C75,C82.C20.C24.C81

192	0200004	C Chip	102 50V ±10% 0603	PCS	7	CC1,CC2,CC3,CC4,CC59,CC66,C15
193	0201005	C Chip	27P 50V ±5% 0603	PCS	2	C14,C13
194	0200006	C Chip	121 50V ±10% 0603	PCS	1	CC55
195	0200008	C Chip	101 50V ±10% 0603	PCS	3	C77.C84,CC15
196	0200011	C Chip	104 25V ±10% 0603	PCS	65	B3~4,B6~9,B11,B13~23,C23,C34,C49, B28~29.B32~35,B38~43,B48~51, B55~56,C56,C65,C97~98,CC5,C7~8, CC13~14,CC22,CC24,CC26~27,CC34, CC38~39,CC44,CC46,CC49,CC56~57, CC70,CC72,CC75,B1.B37
197	0200014	C Chip	471 50V ±10% 0603	PCS	12	CC41,CC43,C1,C2,C3,C4,C9,C10,C11, C12.CC30.CC33
198	0200015	C Chip	153 50V ±10% 0603	PCS	2	CC31,CC32
199	0200016	C Chip	333 50V ±10% 0603	PCS	1	CC61
200	0200017	C Chip	103 50V ±10% 0603	PCS	4	CC40,CC42,CC45,CC62
201	0200034	C Chip	224 10V ±10% 0603	PCS	1	CC58
202	0200021	C Chip	1U 10V ±10% 0603	PCS	5	CC10,CC12,CC20,CC81,CC83
203	0200030	C Chip	472 50V ±10% 0603	PCS	2	CC6,CC11
204	0200031	C Chip	473 50V ±10% 0603	PCS	2	CC53,CC21
205	0200032	C Chip	222 50V ±10% 0603	PCS	4	CC50,CC51,CC52,CC54
206	0201012	C Chip	33P 50V ±5% 0603	PCS	3	CC35,CC36,CC37
207	0200033	C Chip	682 50V ±10% 0603	PCS	2	CC17.CC28
208	0200026	C Chip	68P 50V ±10% 0603	PCS	1	CC23
209	0201024	C Chip	161 50V ±5% 0603	PCS	1	CC60
210	0203007	C Chip	47P 25V ±5% 0603	PCS	1	CC25
211	0203008	C Chip	821 25V ±5% 0603	PCS	1	CC47

212	0250006	Bead core	RH3.5*4.7*0.8	PCS	9	LL3,LL4,LL5,LL6,L6,L7,L8,L9,FB1
213	0250010	Coil chip	(0805)3.3UH	PCS	1	FB3
214	0250028	Bead core Chip	(0805)FB	PCS	8	FB2,FB4,LL2,LL1.L10.L11.L12.L15
215	0250038	Coil chip	2.4UH ±10% 0805	PCS	5	L1,L2,L3,L4,L5
216	0320004	Diode	1N4148	PCS	4	DD1,DD2,DD3,D11
217	0390003	Diode Chip	BAT54S (SOT-23)	PCS	5	D1,D2,D3,D4,D5
218	0460004	TR Chip	9015	PCS	1	QQ7
219	0460001	TR Chip	2N3904	PCS	7	Q1,Q12,Q17.Q13.Q5.Q18.Q19
220	0460007	TR Chip	2N3906 (SOT23)	PCS	8	Q7,Q23.Q25.Q27.Q26.Q28.Q31.Q24
221	0460017	TR Chip	2SB1132 (SOT-89)	PCS	2	QQ1,QQ2
222	0510130	IC	F4558S (SOP)	PCS	1	U15
223	0510168	IC	HY57V641620HGT-H	PCS	1	U7
224	0510241	IC	AM5868S	PCS	1	UU4
225	0510219	IC	EM6353-4.4V	PCS	1	U6
226	0510195	IC	AMS1117-ADJ (SOT-223)	PCS	1	Q2
227	0510245	IC	S524C20D21-SCT0 (SOP)	PCS	1	U3
228	0510237	IC	A29800UV-70 AMIC 5V	PCS	1	U2
229	0510157	IC	ES6603 TQFP64	PCS	1	UU1
230	0510251	IC	ES6698FD PQFP208	PCS	1	U1
231	0510171	IC	DA1132 SSOP-20	PCS	1	U8
232	0610010	X-tal	27MHz 27P (HC-49/S)	PCS	1	Y1
233	1000234	Bare PCB	MESS003 REV:B2 MPEG	PCS	1	
234	1150106	AV Jack	4 jacks AV4-8.4-13D	PCS	1	P3
235	1150115	S-video Jack	DSW-007	PCS	1	P2
236	0050018	R Chip	1/16w470E ±5% 0603	PCS	2	R125.R128
237	0460008	TR Chip	SS8050 (SOT23)	PCS	2	Q14.Q16

238	1150005	Connector Jack	XH-6Pin 2.54mm	PCS	1	JP1
239	1150039	Connector Jack	HOP1200/-24Pin 0.5mm AXIAL	PCS	1	JJ1
240	1150047	Connector Jack	XH-10Pin 2.0mm	PCS	1	J6
241	0201009	C Chip	20P 50V ±5% 0603	PCS	1	C5
242	1150043	Connector Jack	XH-9Pin 2.54mm	PCS	1	JP3
243	0050014	R Chip	1/16w240E ±5% 0603	PCS	28	R181.R84.R183.R136.R186.R185.R146. R145.R188.R187.R142.R143.R118. R119.R189.R190.R179.R180.R149.R150 R126.R177.R178.R133.R182.R147.R83. R184
244	1150003	Connector Jack	XH-4Pin 2.54mm	PCS	1	JP2
245	1150041	Connector Jack	XH-9Pin 2.0mm	PCS	1	J1
246	0000100	R carbon film	2W 3.3E ±5%	PCS	1	L16
247	0050061	R Chip	1/16w1.5K ±5% 0603	PCS	2	RR64,RR70
248	0050124	R Chip	1/16w 100E ±1% 0603	PCS	1	R69
249	0201032	C Chip	152 25V ±5% 0603	PCS	2	C78.C85
250	1150105	Optical Jack	TX179AFT	PCS	1	P1
251	5900065	Remote control	DVG-8500N	PCS	1	
252	1310335	Connector	2.0 9P*120mm red-white reversed direction	PCS	1	from loader to Mpeg board
253	4500059	Pad Foam	DVD Small 200*40*18mm	PCS	3	on Top cover 2, on Front panel1
254	4600013	PE bag for power cord	04*80*240mm	PCS	1	
255	5300377	User's manual	DV-700S	PCS	1	
256	5420082	Warranty Card	DV-500(Poland)	PCS	1	
257	0510151	IC	S0110GS-685(GVG2003)	PCS	1	for remocon
258	5440086	Cushion	10x10x7mm	PCS	1	
259	5440090	Cushion	20x10x4mm Rigidity:25	PCS	2	on loader
260	5000070	Copper sheet	100*15mm	PCS	1	Bus wire

261	5400011	POP shop list	DV-500 Poland	PCS	1	
-----	---------	---------------	---------------	-----	---	--