

PWPC5425B1

CON102

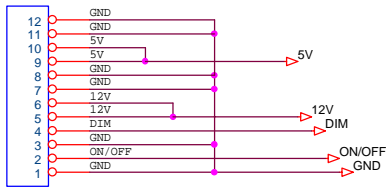

33A8009-12G-H

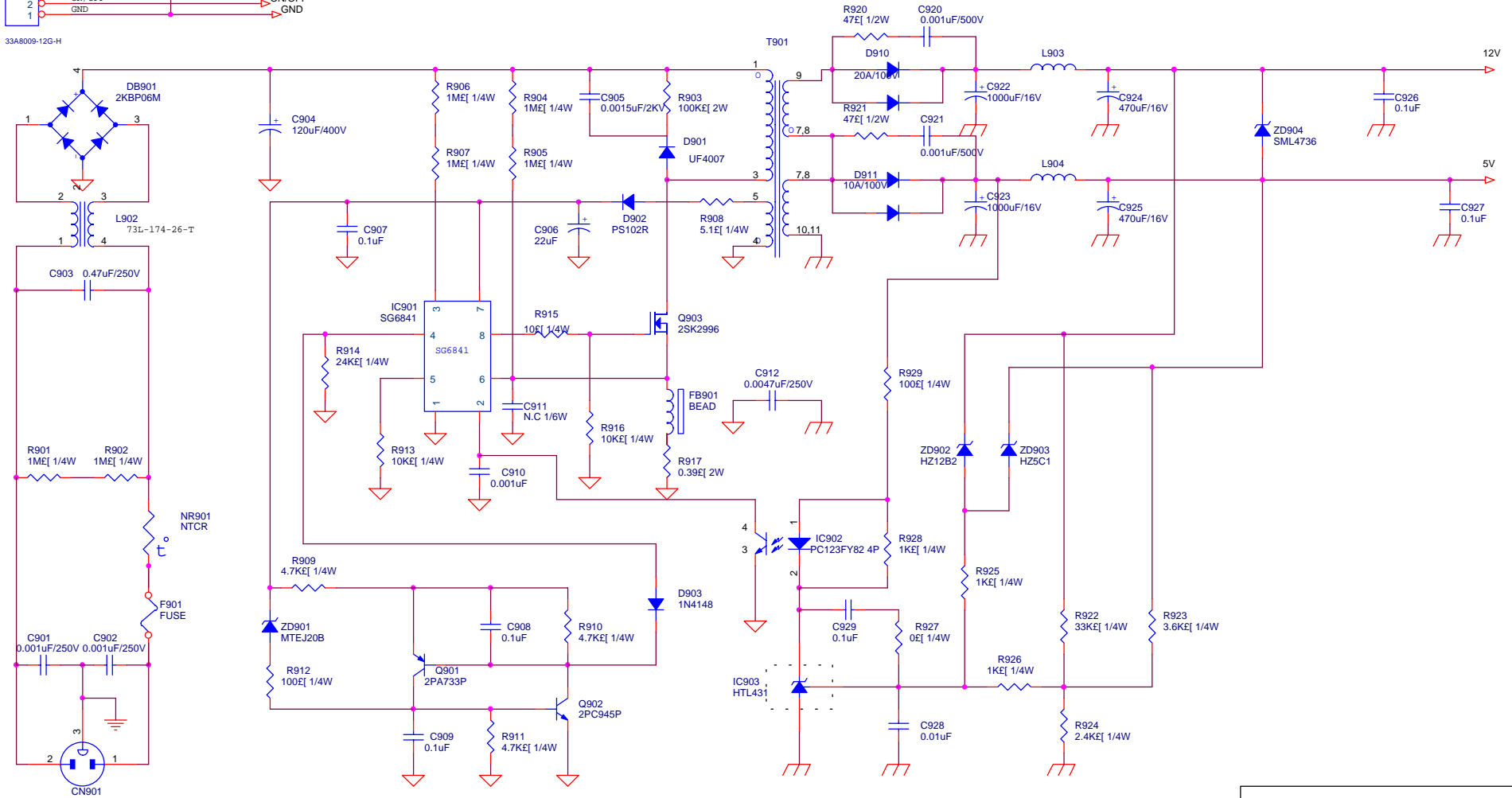

AOC (Top Victory) Electronics Co., Ltd.

Title

1. POWER 12V&5V OUTPUT

Size Document Number PWPC5425B1(715L-1063-1) Rev A

Date: Tuesday, March 25, 2003 Sheet 2 of 2

IDPC7425A6

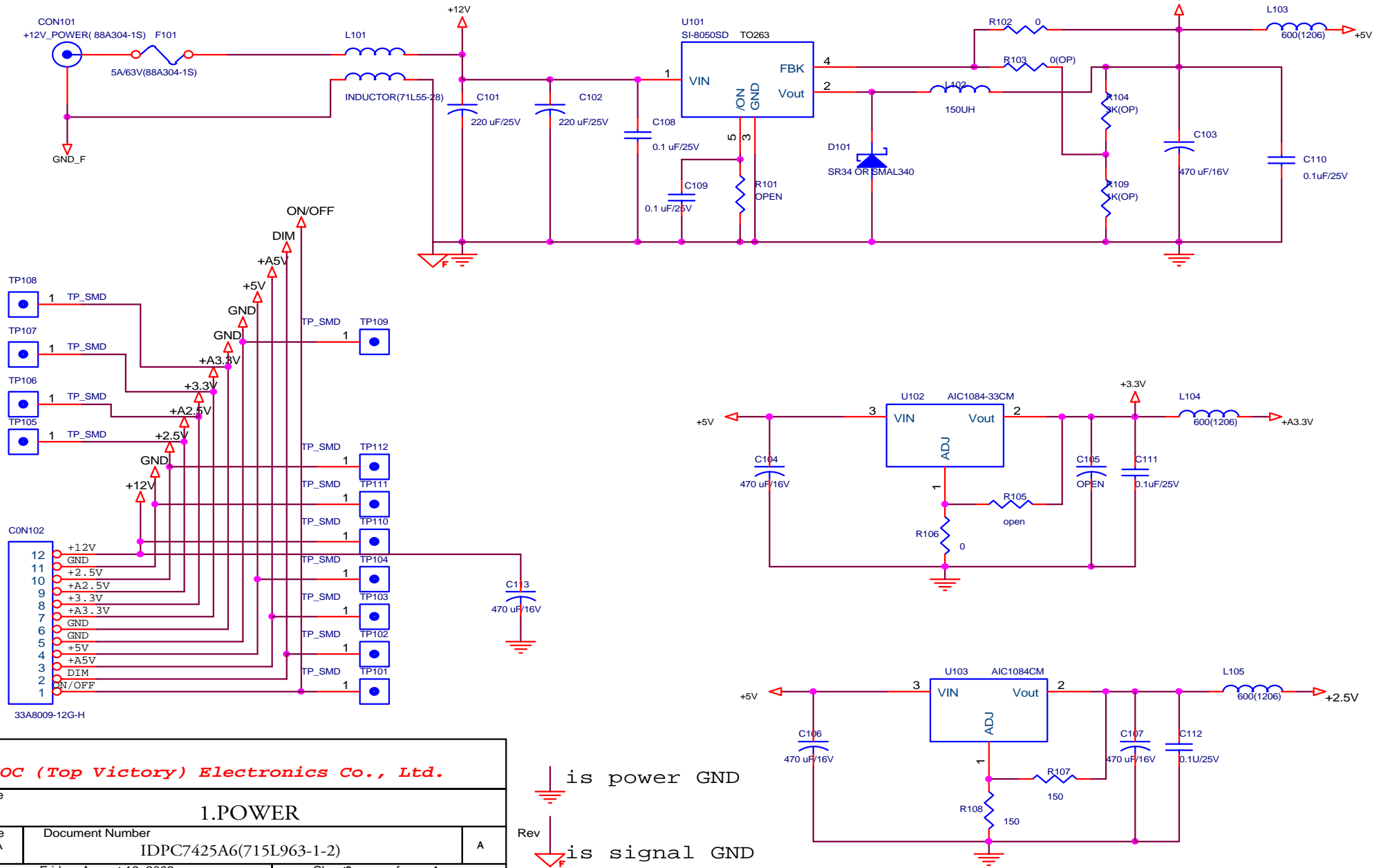

AOC (Top Victory) Electronics Co., Ltd.

Title: **1.POWER**

Size A Document Number: IDPC7425A6(715L963-1-2) A

Date: Friday, August 16, 2002 Sheet 2 of 1

is power GND
 is signal GND

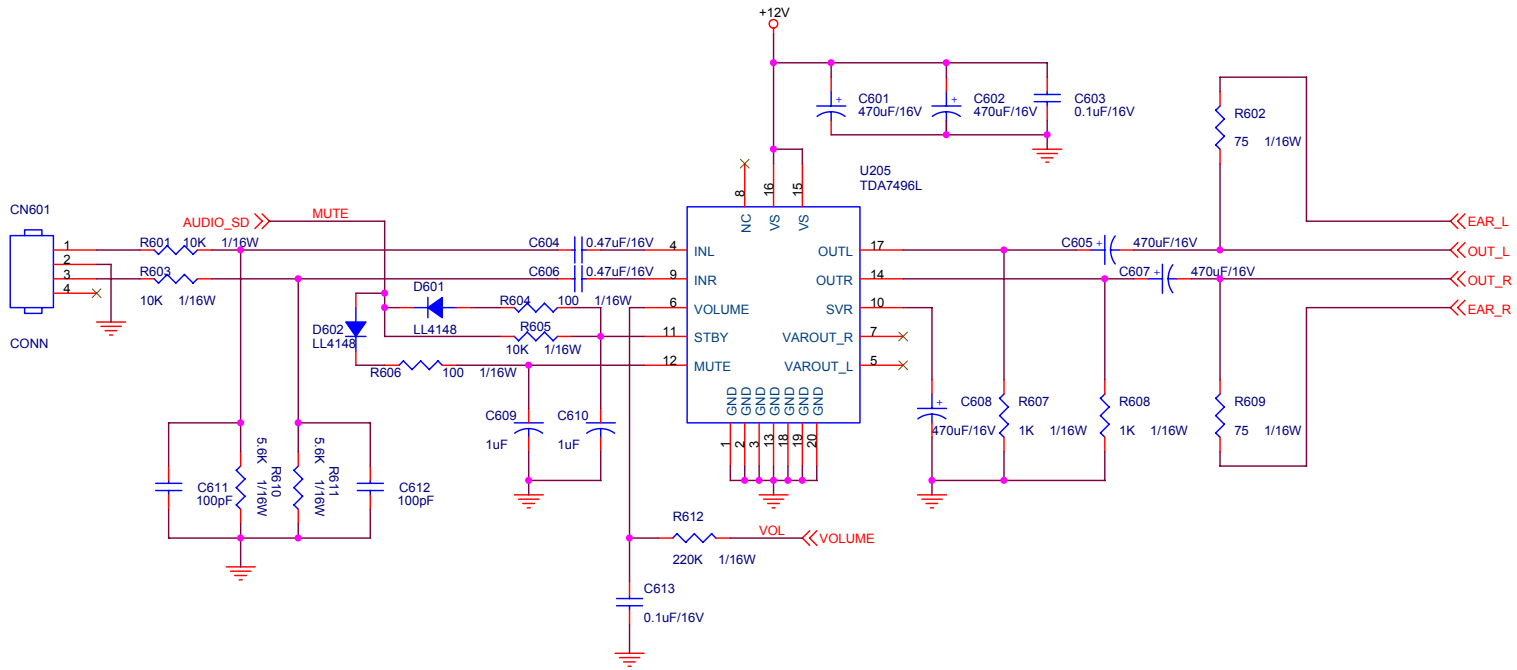

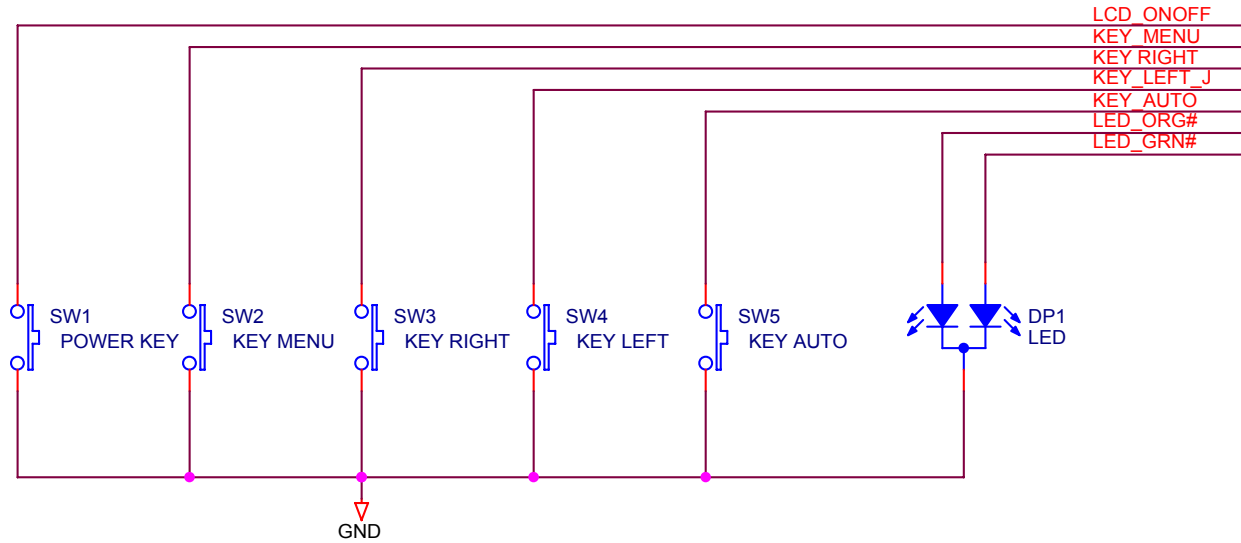
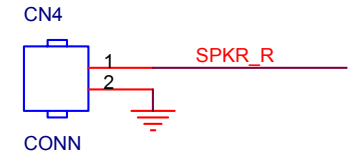
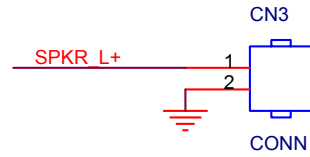
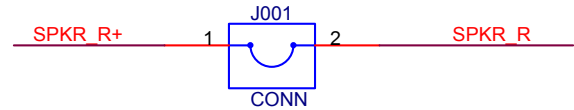
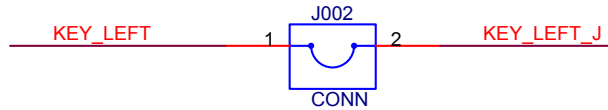
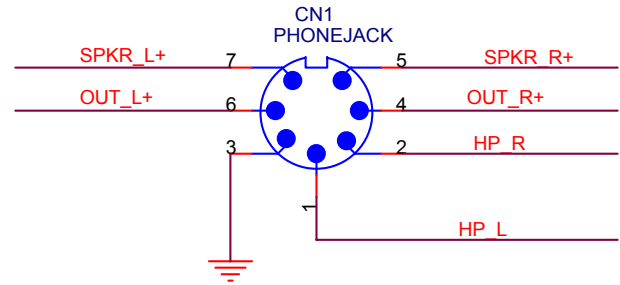
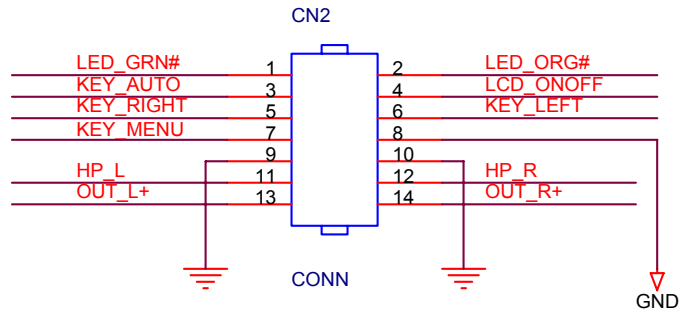

Title		Audio AMP
Size	Document Number	<Doc>
B		
Date:	Friday, August 22, 2003	

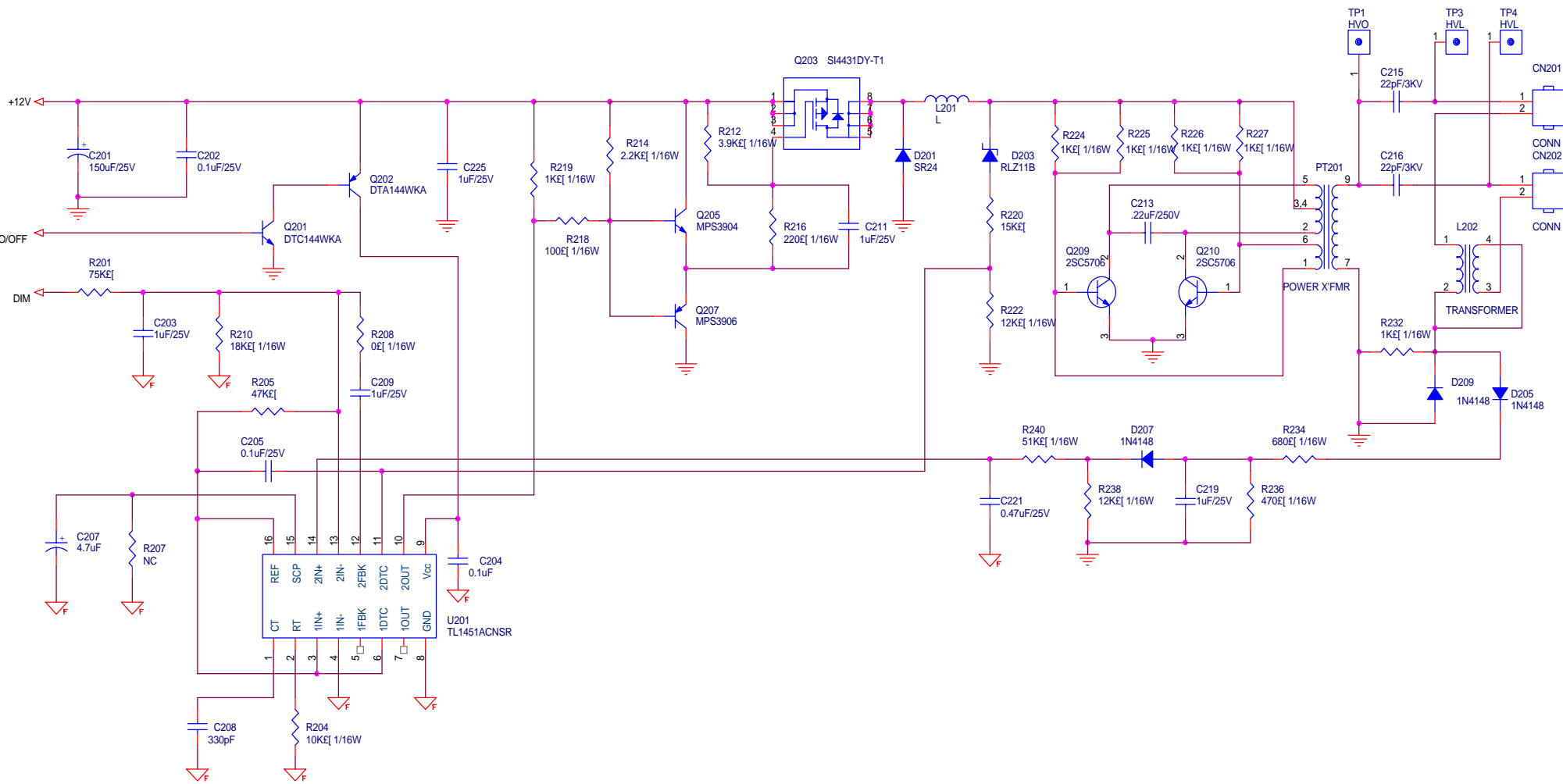

<i>AOC (Top Victory) Electronics Co., Ltd.</i>		
Title		
KEY PAD 715L1071-A		
Size	Document Number	Rev
A	CONTROL KEY PAD (Switch)	A
Date:	Thursday, January 09, 2003	Sheet 1 of 1



 is power GND

 is signal GND

AOC (Top Victory) Electronics Co., Ltd.		
Title		
FOR CPT CLAA150XG 07 INVERTER		
Size	Document Number	Rev
B		2
Date:	Friday, February 14, 2003	Sheet 2 of 2

IDPC5425A1

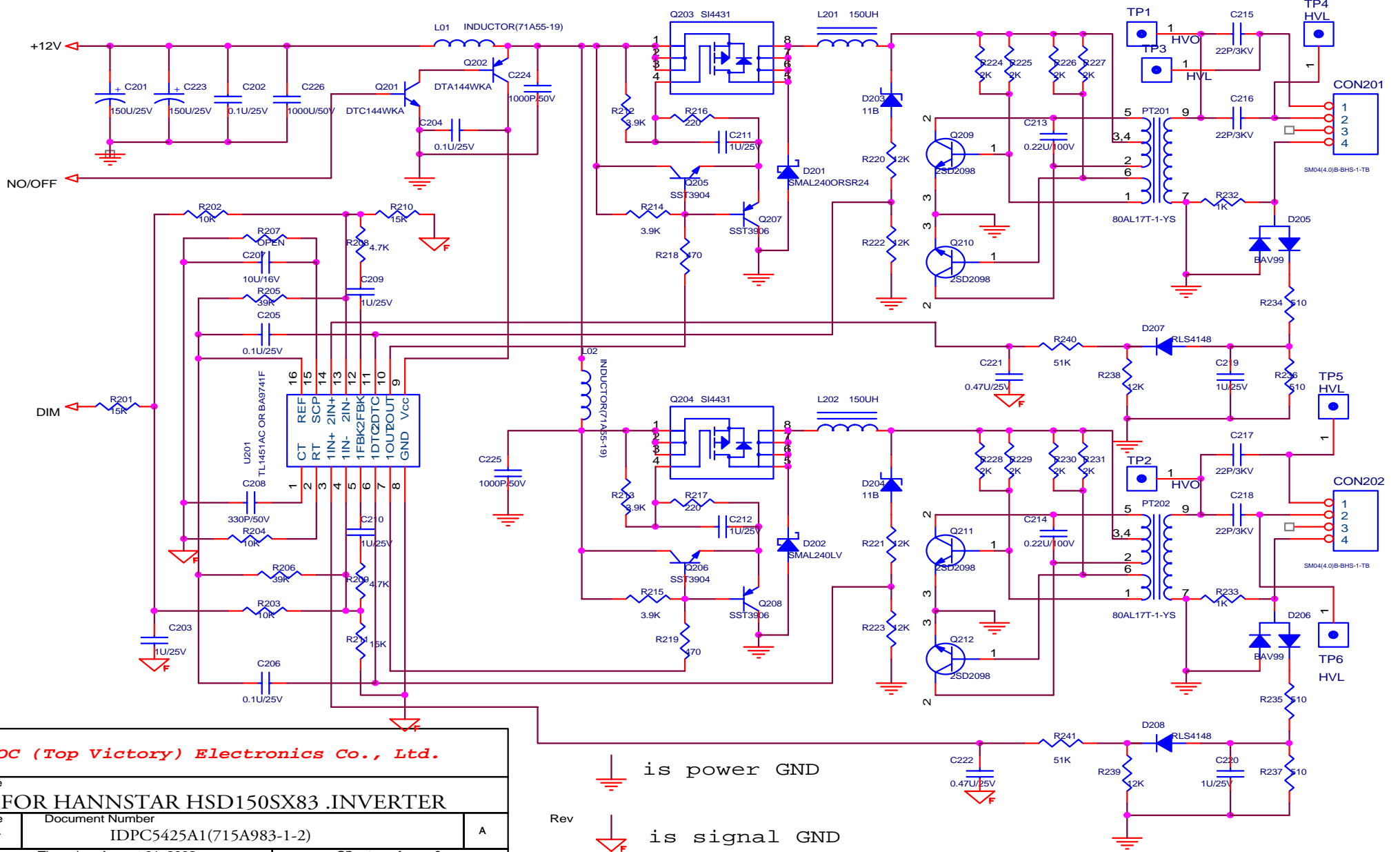

AOC (Top Victory) Electronics Co., Ltd.

Title
2. FOR HANNSTAR HSD150SX83 .INVERTER

Size A	Document Number IDPC5425A1(715A983-1-2)	A
Date: Thursday, August 01, 2002	Sheet of 2	

is power GND

Rev
is signal GND

INPC7425A1

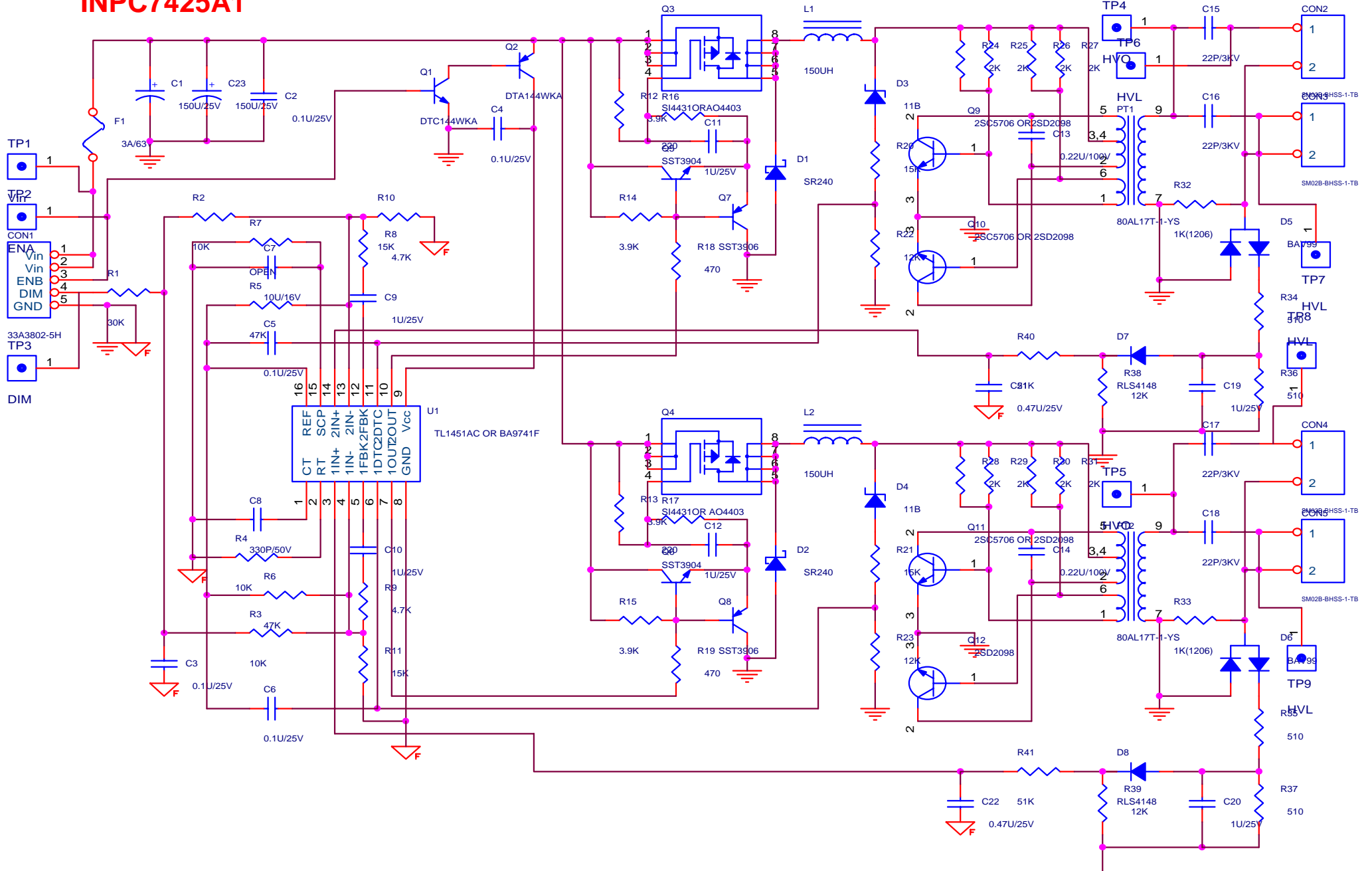

Pwpc7425B1

TO INVERTER

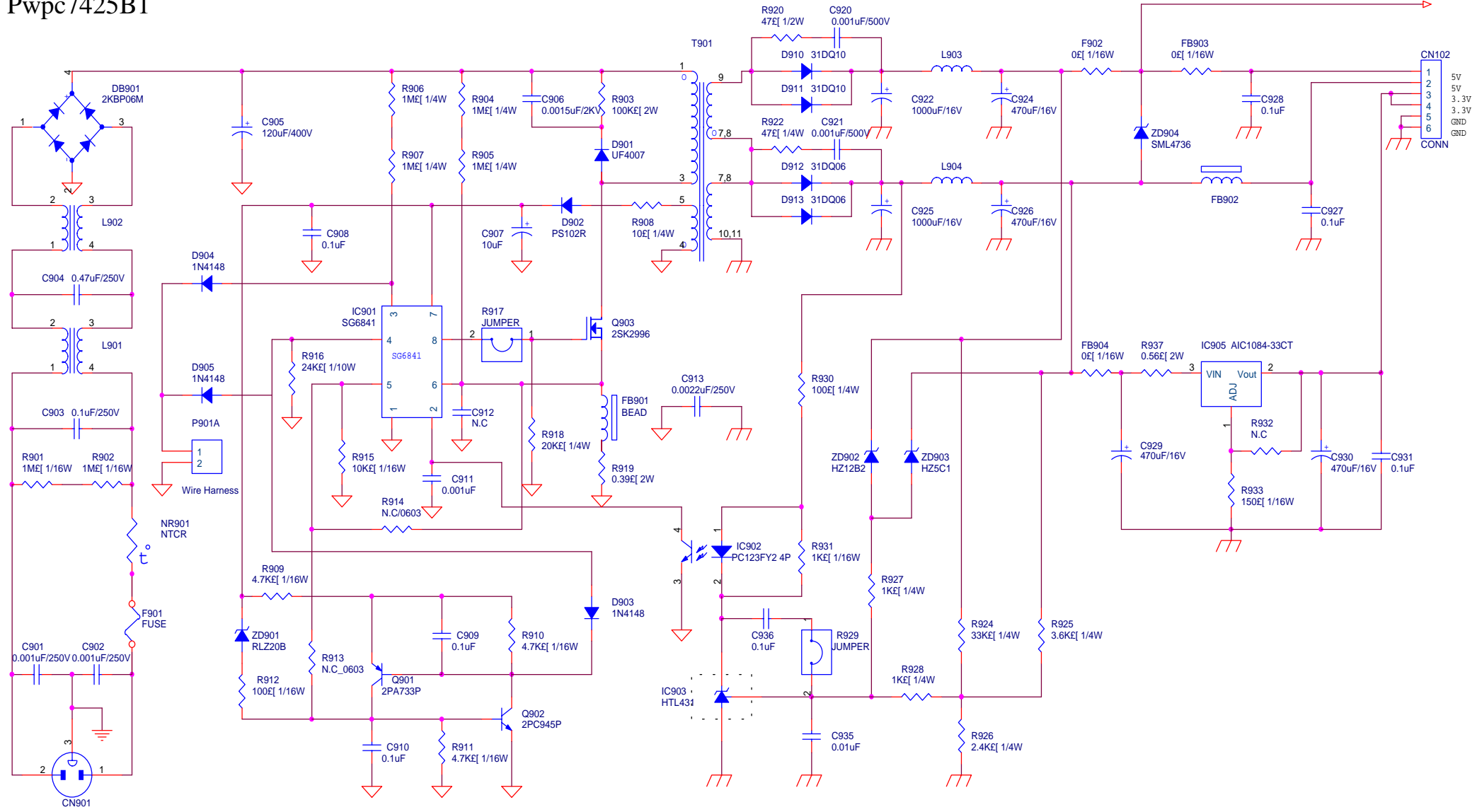

<Title>		
POWER / INVERTER / AUDIO		
Size B	Document Number 71511013-B	Rev 1
Date: Saturday, May 17, 2003	Sheet 1	of 3

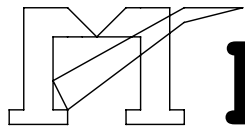

MST8031/8131 SCHEMATIC

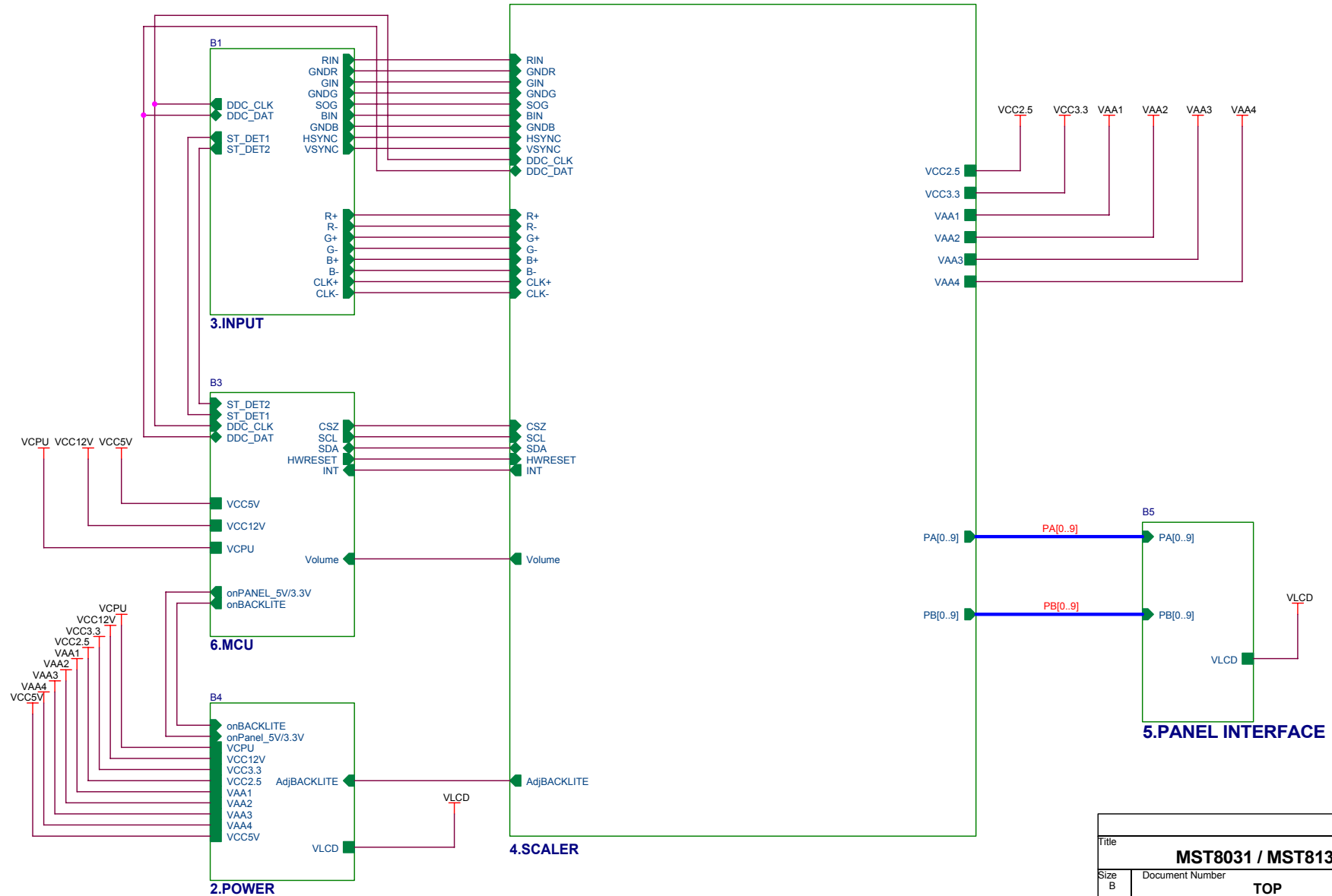

Title		
MST8031 / MST8131 for AOC		
Size B	Document Number	Rev A
TOP		
Date:	Thursday, May 08, 2003	Sheet 1 of 6

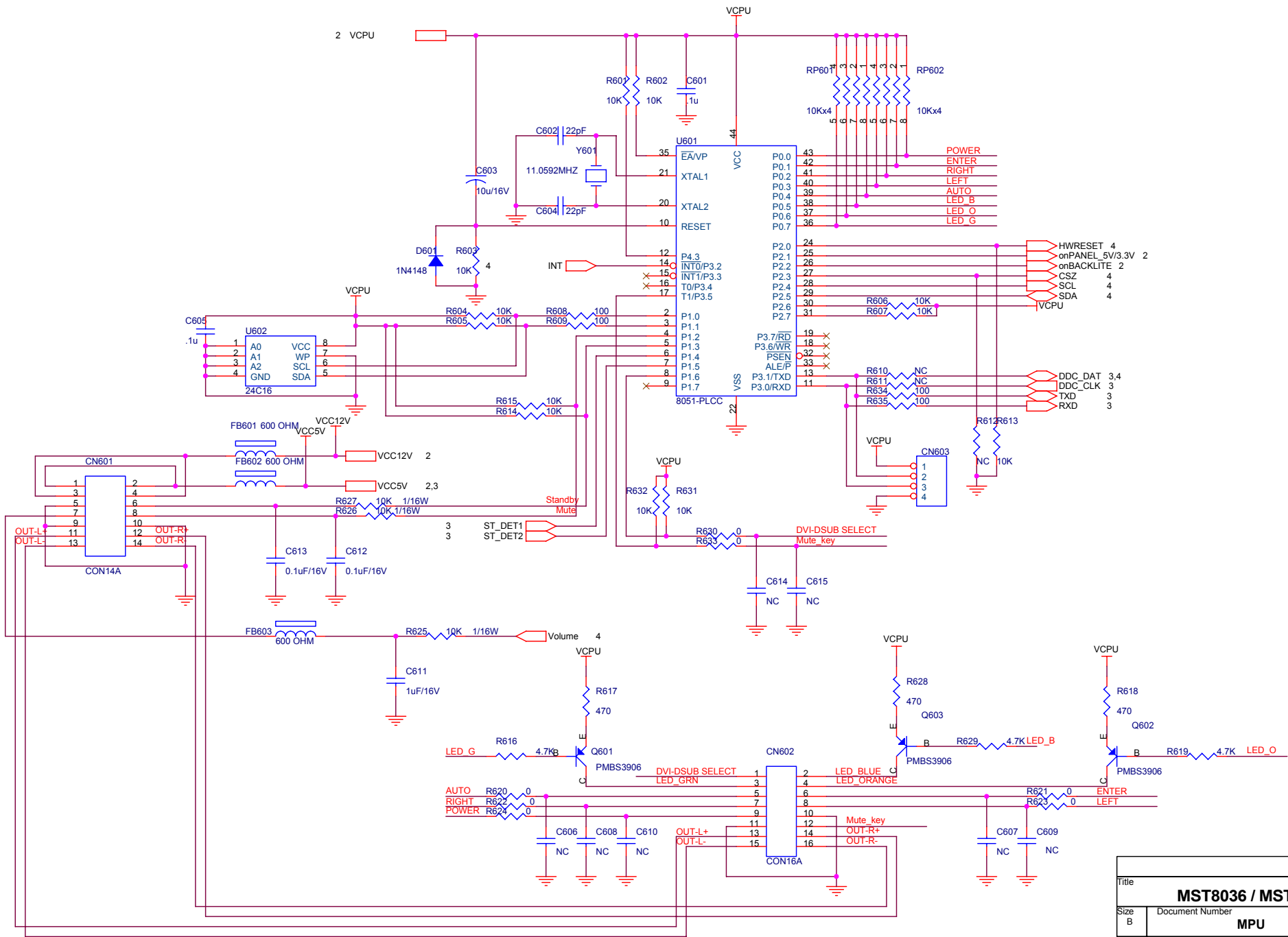

Title		MST8036 / MST8136 for AOC	
Size	Document Number	MPU	
Date:	Wednesday, June 25, 2003	Sheet	6 of 6

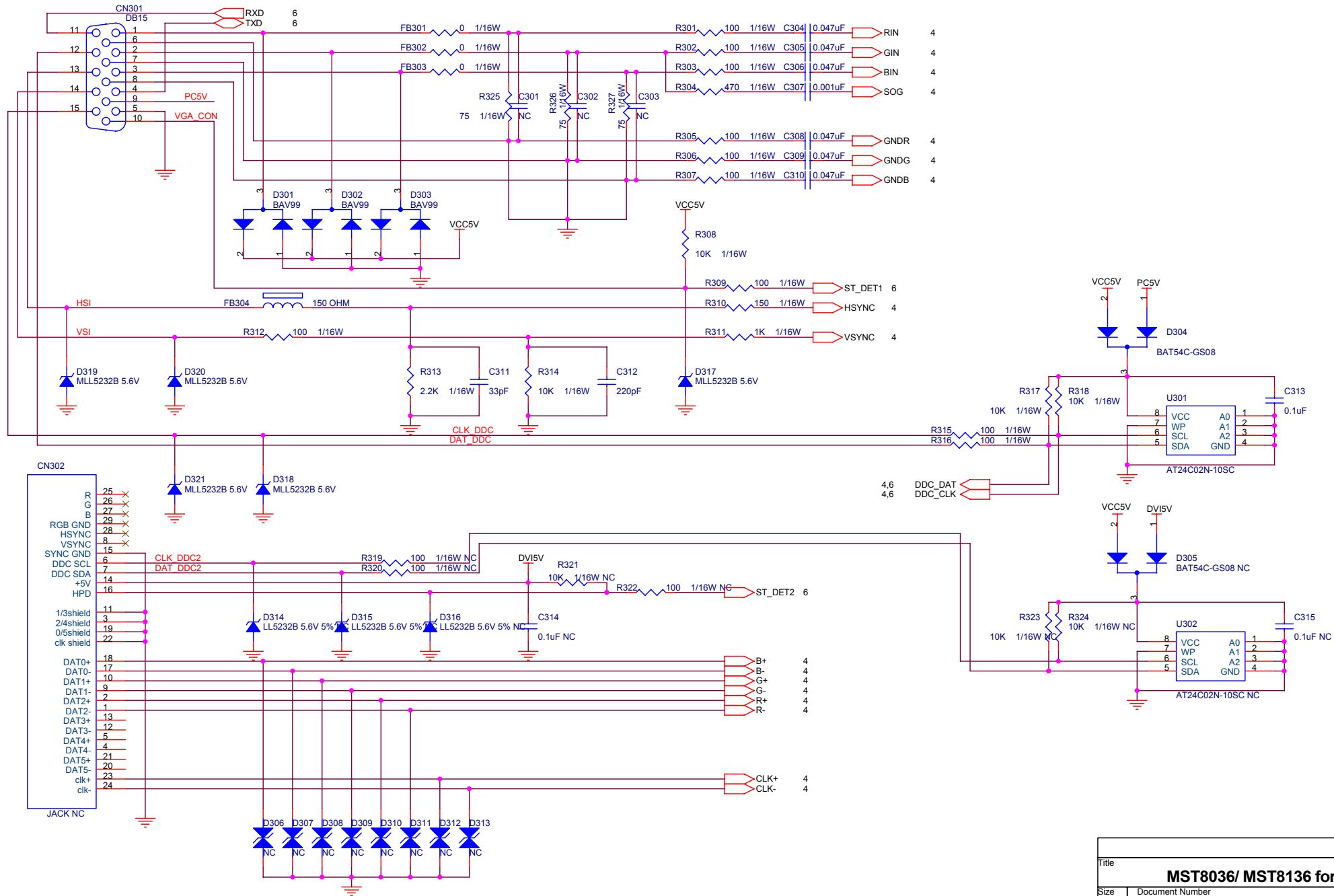

Title		MST8036/ MST8136 for AOC	
Size	Document Number		
B	INPUT		
Date:	Wednesday, June 25, 2003	Sheet	3 of 6