

# **IBK**

LD2006SI-2

## **service manual**



LD1506SI-2      LD1506SI-3      LT1500S-2  
LT1500S-3    LT2000S    LD1906SI    LT1900S

## Explanation to LD2006SI-2 derived machines

LD2006SI-2 is a LCD TV with multiple functions. It adopts MST718 as main chip (MST718 has built-in MCU and video processor). Video main board of this machine adopts 21903-X series PCB (only small changes are made in PCB board numbers and service manual of LD2006SI-2 adopts the video main board of 21903-5). This PCB integrates the circuit of DVD function and DVB function on video main board. This PCB is widely used and there are many derived machines. Now we will introduce functions and machine structure of several derived machines one by one. We list the following for readers to used in order to know differences between each model.

List of Differences in Different Models

Model	Video main board	TV button board	Remote control receiving board	USB board	Headph one board	DVD button board	Power board	Inverter	Conne cting board	Display screen	Remark
LD1506SI-2	21903-5	41903-0	B1506-0	D1903-1	H1903-1	J1903-0	Adapter AK083-3	INV203-2		SVA150XG 04TB 15" TFT	Based on LD2006SI-2, change display screen to 15" screen, change power board to adapter and make the relevant changes in video main board
LD1506SI-3	21903-5	41903-0	B1506-0	D1903-1	H1903-1	J1903-0	Adapter AK083-3	INV203-2		BOEHT150 X02-100 15" TFT	Based on LD1506SI-2, change MST718BE to MST718BU PQFP, change the manufacturer of display screen
LT1500S-2	21903-5	41903-0	B1506-0		H1903-1		Adapter AK083-3	INV203-2		SVA150XG 04TB 15" TFT	Based on LD1506SI-2, cancel DVD and card read function
LT1500S-3	21903-5	41903-0	B1506-0		H1903-1		Adapter AK083-3	INV203-2		BOEHT150 X02-100 15" TFT	Based on LD1506SI-3, cancel DVD and card read function
LD1906SI	21903-6	41903-0	B1903-1	D1903-1	H1903-1	J1903-0	Adapter AK083-3	INV403		M190A1-L02 19" TFT	Based on LD1506SI-2, change display screen and the matching circuit
LT1900S	21903-6	41903-0	B1903-1		H1903-1		Adapter AK083-3	INV403		M190A1-L02 19" TFT	Based on LD1906SI, cancel DVD and card read function
LT2000S	21903-5	41903-0	B1903-1		H1903-1		@52006-2UL	INV607	G2006 SI-0	LC201V02-SDB1 20" TFT	Based on LD2006SI-2, cancel DVD and card read function
LD2006SI-2	21903-5	41903-0	B1903-1	D1903-1	H1903-1	J1903-0	@52006-2UL	INV607	G2006 SI-0	LC201V02-SDB1 20" TFT	Adopt MST718BE+20" TFT screen

#### 1. Introduction to LT2000S model

Based on LD2006SI-2, LT2000S cancels DVD/card read function, but other circuit and components are totally the same with those of LD2006SI-2. Compared with LD2006SI-2 on the aspect of composition of the player, LT2000S has no PCB components of USB board /DVD button board/video main board (DVD function circuit is absent). As for working principle, we will not give any introduction, so please refer to "LD2006SI-2 Service Manual".

#### 2. Introduction to LD1506SI-2 model

LD1506SI-2 is a 15" LCD TV, which changes display screen to 15" LCD TFT screen on the basis of LD2006SI-2. According to parameters requirements, drive means and inverter components are changed. Differences on video main board: 1) LD1506SI-2 adopts LVDS output means, while LD2006SI-2 adopts TTL output means, so the peripheral circuit of LCD drive output part on MST718 has slight difference; 2) 15" screen adopts 5V power supply, so IC702 is added to act as voltage stabilizing IC; 20" screen adopts 12V power supply, so there is no need to add voltage stabilizing IC; 3) LD1506SI-2 adds VGA input circuit according to design requirements to make the machine use as display; 4) LD1506SI-2 adopts adapter (AK083-3) to supply power, while LD2006SI adopts internal power board to supply power, so power input end is added on video main board. Remark: as for inverter components and power adapter working principle of this machine, you may refer to "LD1506SI Service Manual"; as for video main board and other subsidiary board working principle, please refer to "LD2006SI-2 Service Manual".

#### 3. Introduction to LD1506SI-3 model

LD1506SI-3 changes display screen and MST718 on the basis of LD1506SI-2. The main differences are: display screen is changed to BOEHT150X02-100 15" TFT screen; main IC MST718BE is changed to MST718BU PQFP; other parts are totally the same. Please refer to "LD2006SI-2 Service Manual" and "LD1506SI Service Manual" for details of working principle.

#### 4. Introduction to LT1500S-2 model

LT1500S-2 cancels DVD function on the basis of LD1506SI-2 but other parts are totally the same. Please refer to "LD2006SI-2 Service Manual" and "LD1506SI Service Manual".

#### 5. Introduction to LT1500S-3 model

LT1500S-3 changes display screen and MST718 on the basis of LT1500S-2. The main differences are: display screen is changed to BOEHT150X02-100 15" TFT screen; main IC MST718BE is changed to MST718BU PQFP; other parts are totally the same. Please refer to "LD2006SI-2 Service Manual" and "LD1506SI Service Manual" for details of working principle.

## 6. Introduction to LD1906SI

LD1906SI changes display screen to 19" TFT screen on the basis of LD1506SI-2. Because of this, boost components has alteration, that is, boost components are changed to INV403 (working principle is the same with INV607 and you may refer to "LT2002S Service Manual). Display screen drive adopts LVDS input method and other circuits' working principle is totally the same with that of LD2006SI-2. During the course of servicing, please refer to "LD2006SI-2 Service Manual".

## 7. Introduction to LT1900S model

LT1900S cancels DVD function on the basis of LD1906SI and other parts are totally the same with those of LD1906SI. Please refer to "LD2006SI-2 Service Manual" for details of working principle.

# Catalog

Chapter One About Maintenance .....	1
1.1 Safety precautions .....	1
1.1.1 Power supply .....	1
1.1.2 Precautions for antistatic .....	1
1.1.3 Precautions for display screen .....	1
1.1.4 Precautions for laser head .....	2
1.1.5 About placement position .....	2
1.2 Maintenance method .....	2
1.2.1 Electric resistance method .....	2
1.2.2 Voltage method .....	2
1.2.3 Current method .....	2
1.2.4 Element substitution method .....	2
1.2.5 Cutting method .....	2
1.2.6 Visualized method .....	3
1.2.7 Comparison method .....	3
1.3 Required device for maintenance .....	3
Chapter Two Functions and Operation Instructions .....	4
Section One TV SEGMENT .....	4
2.1.1 Features .....	4
2.1.2 Set list .....	5
2.1.3 CONTROLS AND FUNCTIONS .....	5
2.1.4 CONNECTION AND STARTING .....	7
2.1.5 TV MODE .....	7
Section Two DVD SEGMENT .....	9
2.2.1 Controls and functions .....	9
2.2.2 FUNCTION SETTINGS .....	9
2.2.3 OTHERS .....	12

## Chapter Three Principle and Servicing

The previous manual: TV part .....	15
Section One Principle of the player .....	15
3.1.1 Function .....	15
3.1.2 Block diagram of the player .....	15
3.1.3 Function introduction to IC of the player .....	17
Section Two Unit Circuit Principle .....	18
3.2.1 System control circuit .....	18
3.2.2 Audio circuit .....	22
3.2.3 Video circuit .....	26
3.2.4 Input circuit .....	27
3.2.5 Power circuit .....	29
Section Three Servicing Cases .....	34
3.3.1 Servicing cases .....	34
3.3.2 Troubleshooting flow chart .....	42
Section Four Waveform diagram .....	54
Section Five Function Introduction to IC .....	63
3.5.1 function introduction to SDRAM .....	63
3.5.2 function introduction to STV8216 .....	64
3.5.3 function introduction to MST718 .....	67
3.5.4 function introduction to Cd4052 .....	73
3.5.5 function introduction to TDA7266D .....	75
3.5.6 function introduction to FSAV433 .....	75
3.5.7 function introduction to HEF4094B .....	76

## Section Three Servicing and Principle

The next manual: DVD part .....	78
Section One Principle of the player .....	78
3.1.1 Introduction to the player .....	78
3.1.2 Introduction to IC used by the player .....	78
Section Two Unit Circuit Principle .....	79
3.2.1 Introduction to laser head .....	79
3.2.2 Servo circuit .....	80
3.2.3 Laser power control circuit .....	82
3.2.4 CD/DVD conversion circuit .....	93

3.2.5 Disc slot-in circuit .....	84
3.2.6 Disc in/out circuit .....	85
3.2.7 Main axis control circuit .....	87
3.2.8 Decode circuit .....	88
3.2.9 Reset circuit .....	89
3.2.10 Video circuit .....	90
3.2.11 Audio circuit .....	91
3.2.12 USB/CARD circuit .....	91
Section Three Servicing Cases .....	93
3.3.1 Servicing cases .....	93
3.3.2 Troubleshooting flow chart .....	95
Section Four Waveform diagram .....	101
Section Five Function Introduction to IC .....	106
3.5.1 function introduction to MT1389HD .....	106
3.5.2 function introduction to FLASH .....	122
3.5.3 function introduction to D5954 .....	122
3.5.4 function introduction to 4558/4580 .....	123
3.5.5 function introduction to 24CC02A .....	124
Chapter Four Disassembly and Assembly Process .....	125
Chapter Cinque PCB board & Circuit diagram .....	128
Section One PCB board .....	128
Section Two Circuit diagram .....	134
Chapter six BOM List .....	152

# Chapter One About Maintenance

## 1.1 Safety precautions

### 1.1.1 Power supply

When maintenance personnel are repairing DVD TV, he should pay special attention to the power with 220V 800V AC and 330V DC which will cause hurt and damage to persons!

### 1.1.2 Precautions for antistatic

Movement and friction will both bring static electricity which causes serious damages to integrated IC. Though static charge is little, when a limited quantity of electric charge is added to large scale integrated IC, as the capacitance is very small in the meantime, now the integrated IC is very much easy to be struck through by static electricity or the performance will decrease. Thus static electricity prevention is of extraordinary importance. The following are several measures to prevent static electricity:

1. Use a piece of electric conduction metal with the length of about 2 metres to insert into the earth, and Fetch the lead wire from the top of the surplus metal and connect to the required static electricity device. The length and depth of the metal embedded under the earth should be determined according to the wettability of the local soil. For humid places, it may be shorter, and longer and deeper for dry places. If possible, it can be distributed and layed in terms of “#” shape.

2. On operating table-board, the antistatic table cushion should be covered and grounded.

3. All devices and equipments should be placed on the antistatic table cushion and grounded.

4. Maintenance personnel should wear antistatic wrist ring which should be grounded.

5. Places around the operating position should also be covered with electric conduction cushion or Painted with antistatic paint.

### 1.1.3 Precautions for display screen

1. Display screen is breakable article, so please protect carefully when carrying and prevent fingers or hard objects striking the screen to damage structure of the screen.

2. When cleaning screen, do not use organic chemicals. You should use cloth and use small amount of special cleaning liquid in places difficult to clean.



### **1.1.4 Precautions for laser head**

1. Do not stare at laser head directly, for laser emission will occur when laser head is working, which will Hurt your eyes!
2. Do not use wiping water or alcohol to clean laser head, and you may use cotton swab.

### **1.1.5 About placement position**

1. Never place TV in positions with high temperature and humidity.
2. Avoid placing near high magnetic fields, such as loudspeaker or magnet.
3. Positions for placement should be stable and secure.

## **1.2 Maintenance method**

### **1.2.1 Electric resistance method**

Set the multimeter in resistance position and test whether the numerical value of resistance of each point in the circuit has difference from the normal value to judge the trouble spot. But in the circuit the tested numerical value of resistance is not accurate, and the tested numerical value of integrated IC's pins can only be used for reference, so the elements should be broken down for test.

### **1.2.2 Voltage method**

Voltage method is relatively convenient, quick and accurate. Set the multimeter in voltage position and test power supply voltage of the player and voltage of a certain point to judge the trouble spot according to the tested voltage variation.

### **1.2.3 Current method**

Set the multimeter in current position and test current of the player of a certain point to judge the trouble spot. But when testing in current method, the multimeter should be series connected in the circuit, which makes this method too trivial and troublesome, so it is less frequently used in reality.

### **1.2.4 Element substitution method**

When some elements cannot be judged good or bad, substitution method may be adopted directly.

### **1.2.5 Cutting method**

Cutting method should be combined with electric resistance method and voltage method to use. This method is mainly used in phenomena of short circuit and current leakage of the circuit. When cutting the input terminal voltage of a certain level, if voltage of the player rises again, it means that the trouble lies in this level.

### **1.2.6 Visualized method**

Directly view whether abnormalities of collision, lack of element, joint welding, shedding welding, rosin joint, copper foil turning up, lead wire disconnection and elements burning up among pins of Elements appear. Check power supply of the machine and then use hands to touch the casing of part of elements and check whether they are hot to judge the trouble spot. You should pay more attention when using this method to check in high voltage parts.

### **1.2.7 Comparison method**

A same good PC board is usually used to test the correct voltage and waveform. Compared these data with those tested through fault PC board, the cause of troubles may be found.

Through the above maintenance method, theoretical knowledge and maintenance experience, all difficulties and troubles will be readily solved.

## **1.3 Required device for maintenance**

- ◆ Audio Generator
- ◆ Digital oscillograph ( $\geq 100\text{MHE}$ )
- ◆ SMD rework station
- ◆ Multimeter
- ◆ Soldering iron
- ◆ Pointed-month pincers
- ◆ Cutting nippers
- ◆ Forceps
- ◆ Electric screw driver
- ◆ Terminals connecting cord
- ◆ Headphone
- ◆ Microphone

# Chapter Two

## Functions and Operation Instructions

### Section One TV SEGMENT

#### 2.1.1 Features

##### Technical Features

- #High quality color TFT panel
- #Maximum resolution 640X480 for LD2006SI
- #Built-in DVD player with Slot-in mechanism
- #Multisystem TV tuner with NICAM decoding
- #Built-in stereo audio system
- #USB port to playback compatible files stored on flash memory of external devices
- #Composite video ,audio input
- #Component, RGB/SCART and video inputs
- #Digital coaxial output for multi-channel sound playback
- #Headphones output
- #Universal holder for furniture or wall fixation with 270 rotation angle

##### TV Channels Receiving and External Signal Playback

- #Automatic and fine tuning functions with 100 channels memory
- #Adjustable brightness, contrast, saturation, hue and 4 preset image settings
- #Tone and sound balance adjustment and 4 preset audio settings

##### Disc playback mode

- #Digital video playback: DVD-Video, Super VCD, VCD compatibility
- #MPEG-4 standard support
- #Digital audio playback: CD-DA, HDCD and Mp3 compatibility
- #Digital graphic albums playback: Kodak Picture CD and JPEG
- #Compatible disc types: CD-R/CD-RW, DVD-R,/DVD-RW, DVD+R/DVD+RW
- #Russia, CIs and Baltic States adaptation interface and filenames ID3-tags and CD-Text support

simplifies device operation

#"Q-Play" function provides direct playback and allows to skip commercial that is not possible to rewind

#"Browser" function provides easy access to playback control

#Automatic screensaver function

#Parental control function to protect children from watching inappropriate discs

#Super wide range of operating power supplies(~100-240v) automatic short circuit protection

## 2.1.2 Set list

LCD TV.....	1pcs
Remote Control.....	1pcs
AAA Battery.....	2pcs
RCA-RCA cord.....	1pcs
2XRCA-2XRCA cord.....	1pcs
Wall Mount Holder.....	1pcs
Kickstand.....	1pcs
Screw M5X15.....	1pcs
Screw M4X10.....	1pcs
Screw PA5X25.....	4pcs
Screw PM45X10.....	4pcs
Expandable pipe.....	4pcs
User manual.....	1pcs
Warranty Card.....	1pcs

## 2.1.3 CONTROLS AND FUNCTIONS

### (1) Panel controls and indication

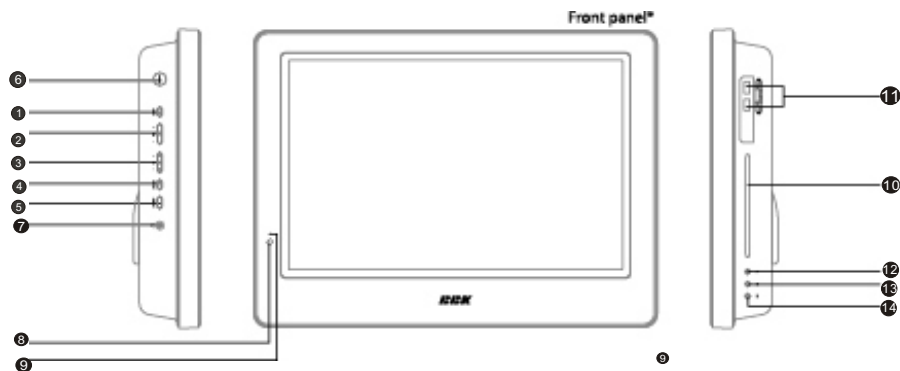

#### Left panel

- ① **SETUP button**  
Press to switch to setup mode
- ② **\_VOL+button**  
Press to adjust the volume.
- ③ **\_CH+button**  
Press to switch between channels/to choose menu item.
- ④ **SOURCE button**  
Press to choose the playback mode.
- ⑤ **STANDBY button**  
Press to switch on the device/into standby mode.
- ⑥ **POWER button**  
Turn on/off the power.
- ⑦ **Headphones output**

#### Front panel

- ⑧ **Remote control sensor**
- ⑨ **Power supply indicator**







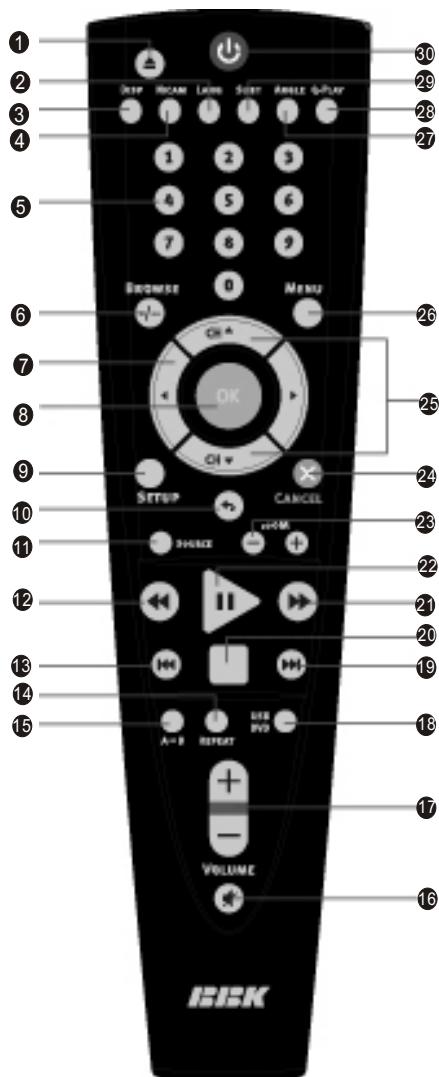



#### Right panel

- ⑩ **Disc tray**
- ⑪ **USB port**
- ⑫ **EJECT button**  
Press to open/close the disc tray.
- ⑬ **STOP button**  
Press to stop the playback.
- ⑭ **PLAY/PAUSE button**  
Press to playback/pause.

## (2) Remote control general view



- 26 **MENU button**  
DVD disk menu/PBC function.
- 27 **ANGLE button**  
Press to change the camera angle/change the Mp3 and JPEG files playback mode.
- 28 **Q-PLAY button**  
Press to turn the Q-PLAY mode on.
- 29 **SUBT button**  
Press to change the subtitles language/change the display mode JPEG files.
- 30 **Button **  
Press to switch on the device/into standby mode.

- 1 **EJECT button**  
Press to open/close the disc tray.
- 2 **LANG button**  
Press to change language.
- 3 **DISP button**  
Press to display the disc information.
- 4 **NICAM button**  
Press to choose audio mode.
- 5 **Numeric buttons**
- 6 **BROWSE button**  
Press to turn on/off the browser function.
- 7 **CURSOR buttons (UP/DOWN/LEFT/RIGHT)**
- 8 **OK button**
- 9 **SETUP button**  
Press to switch to setup mode.
- 10 **Button **  
Press to return to the previous channel.
- 11 **SOURCE button**  
Press to change the TV/DVD mode.
- 12 **Button **  
Press to start rewind/rewind scanning.
- 13 **Button **  
Press to skip backward.
- 14 **REPEAT button**  
Press to repeat.
- 15 **A-B button**  
Press to repeat the selected section.
- 16 **Button **  
Press to turn on/off the sound.
- 17 **VOLUME +/- button**  
Press to adjust the volume.
- 18 **USB/DVD button**  
Press to select USB/DVD mode.
- 19 **Button **  
Press to skip forward.
- 20 **Button **  
Press to stop the playback.
- 21 **Button **  
Press to forward scanning.
- 22 **Button **  
Press to playback/pause.
- 23 **ZOOM +/- button**  
Press to zoom in/out.
- 24 **CANCEL button**  
Press to go one level back/cancel current operation.
- 25 **CH  /  button**  
Press to switch between channels /to choose menu item.

## 2.1.4 CONNECTION AND STARTING

### (1) Switching interfaces

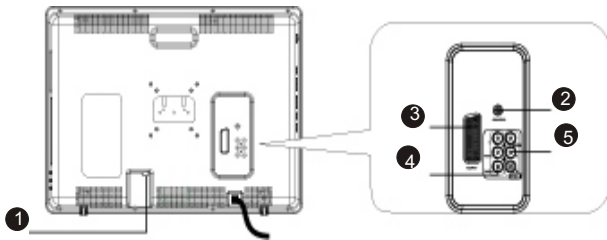

- ① **RF input**  
Meant for antenna connection.
- ② **COAXIAL OUT**  
Meant for multi-channel sound playback.
- ③ **SCART socket**  
Meant for external audio video signal source connection. There is no need to use additional audiocord.
- ④ **Y Cb(Pb) Cr(Pr)**
- ⑤ **AUDIO VIDEO IN**  
Used for external signal source connection.

## 2.1.5 TV MODE

This LCD TV can store up to 100 channels and enables to scan channels thought automatic, manual and fine tuning scanning mode. Built-in TV tuner supports stereo audio playback in NICAM system.

### (1) Adjusted channels selection

- #Press +CH-buttons on the left panel or CH▲/▼ buttons on the remote control each time, when you want to change a channel.
- #Use numeric buttons to enter the number of the channel.
- #Press  button to return to the previous channel.

### (2) Default picture settings selection

- #You may select one of the default picture settings: USER, STANDARD, DYNAMIC and SOFT.

#You may adjust necessary parameters in the device menu.

#Turn to Picture item on this page for details.



### (3) Default sound settings selection

#You may select one of the default sound settings:

USER, MUSIC, FILM and NEWS.

#You may adjust necessary parameters in the device menu.

#Turn to page.13 for details.



### (4) Accompanying sound type

#Only some of the TV channels have stereo accompanying sound in NICAM system.

#Press NICAM button to select accompanying sound.

### (5) TV settings

#Press SETUP button to display the menu.

#Use cursor buttons on the remote control or +CH-buttons on the left panel to select the item. Use ◀/▶ buttons to adjust selected parameter. Use OK button for confirmation. Press SETUP button again to return to the main menu or to exit TV SETUP.



### (6) Picture

#select PICTURE item to adjust picture parameters.

#You may adjust BRIGHTNESS, CONTRAST, SATURATION, TINT, SHARPNESS and COLOR TEMP.



## NOTE

You can't adjust TINT while watching TV channels.

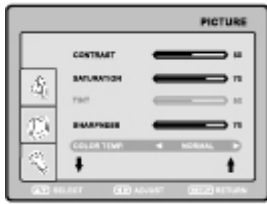

## (7) Sound

#Select SOUND item to adjust sound parameters.

#You may adjust BALANCE, BASS, TREBLE and NICAM.



## (8) TV setup

Select TV SETUP item to adjust channels. CHANNEL, COLOR SYSTEM, SOUND SYSTEM, FINE TUNING, AUTO SEARCH, MANUAL SEARCH and CHANNEL EDIT.

#CHANNEL item enables to select the number of adjustable channel.

#CHANNEL EDIT submenu enables to select, skip and swap the channel.

#CHANNEL parameter enables to select current channel.

#SKIP function enables to make current channel inaccessible while using +CH-button to browse channels.



#SWAP function enables to select the channel number to swap with current channel.

#SAVE parameter enables to confirm the swap function.

#FINE TUNING item enables to adjust the channel frequency accurately.

#MANUAL SEARCH item enables to change channel settings.

#AUTO SEARCH item enables to adjust channel setting automatically.

#COLOR SYSTEM item can be changed between: AUTO, PAL and SECAM. We recommend to set this item to AUTO.

#SOUND SYSTEM item can be changed between: B/G, D/K, Land I.

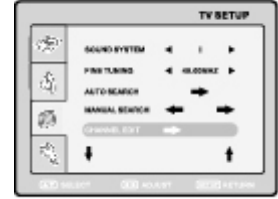
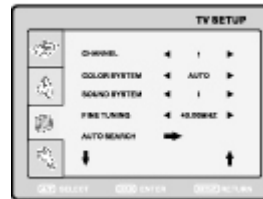

## (9) Function

You may select LANGUAGE, TRANSPARENCY, SLEEP and RATIO.

#LANGUAGE item enables to select the OSD language.

#TRANSPARENCY item enables to adjust transparency of OSD.

#SLEEP item enables to set the sleep timer.

#RESET item enables to reset all values to default.



## (10) Video settings

#Press SETUP button to display the menu.

#In external video signal playback mode the menu is the same as the menu, described on pages 12 and 13.

## NOTE

In external video signal playback mode TV SETUP item is inaccessible.

## Section Two DVD SEGMENT

### 2.2.1 Controls and functions

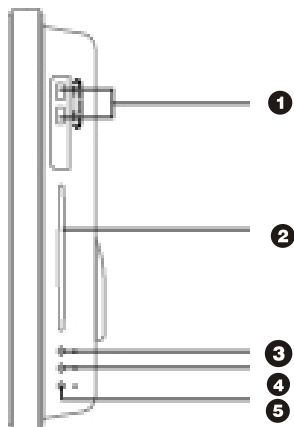

- ① **Two USB PORTS**
- ② **Disc tray**
- ③ **EJECT button**  
Press to open/close the disc tray.
- ④ **STOP button**  
Press to stop the playback.
- ⑤ **PLAY/PAUSE button**  
Press to playback/pause.

### 2.2.2 FUNCTION SETTINGS

#### (1) Function selection and change

#Press the SETUP key to show the setup menu. You will see the following image on the screen, as show on the figure:

#Select the desired menu item using the UP/DOWN buttons button; press the OK key for confirmation.

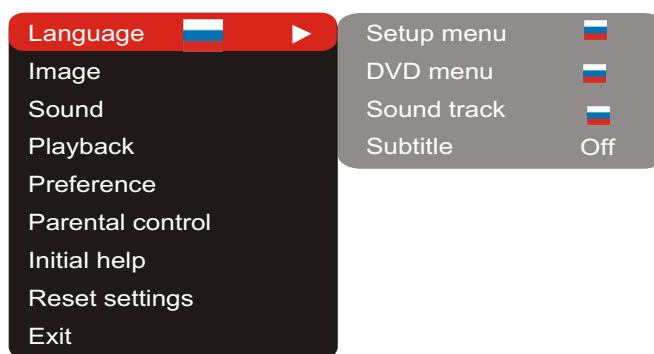

1.For example, if you wish to change the image settings, you have to select the image item and press the OK or RIGHT key.

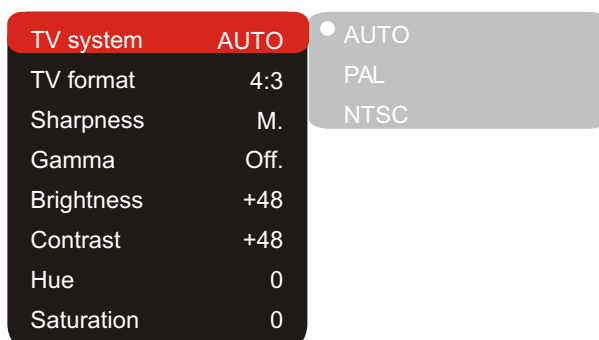



2. Using the UP/DOWN buttons, select the desired item and press OK or RIGHT button. For example, select the Sharpness item. Settings will appear on the screen. Then select the desired sharpness level and press OK for confirmation.

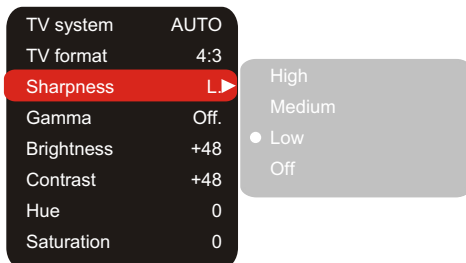

3. Press LEFT for exit to previous menu level.  
4. Press SETUP to exit setup menu.

## (2) Language settings

### 1. Setup menu: interface language set-up

#Options: Russian, English, Ukrainian.

#Default option: English.

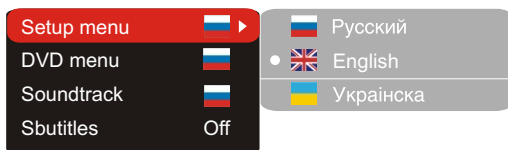

### 2. DVD menu: selection of disc menu language

### 3. Sound: selection of translation language

#Disc menu/translation language options: Russian, English, Estonian, Lithuanian, Kazakh, Romanian, Belarusian, Ukrainian, Chinese.  
#Default menu/translation language option: English.

#Selection of other languages: select the OTHERS item using the wheel and press OK. Enter the language code using the numeric buttons and press OK.

#If the language you selected is not recorded on the DVD disc, another available language will be used.

### 4. Subtitles: selection of subtitles language

#Options: Off, Russian, English, Estonian, Lithuanian, Kazakh, Romanian, Belarusian, Ukrainian, and Chinese.

#Default option: off.

#Selection of other languages: select the OTHERS item using the wheel and press OK. Enter the language code using numeric buttons and press OK.

#If the language you selected is not recorded on the DVD disc, another available language will be displayed.

## (3) Image settings menu

### 1. TV system: TV system selection

#Options: Auto, PAL, NTSC.

#Default option: Auto.

### 2. TV Format: image ratio settings

#Options: 4:3 pan& scan, 16:9 letterbox and 16:9 TV, 4:3 LB.

#Default option: 4:3 LB.

#Some discs are recorded with support of only one ratio. The selected ratio must comply with the TV screen.

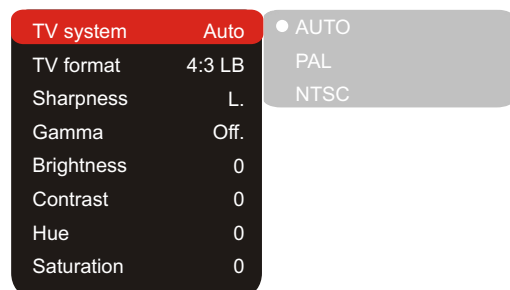

### 3. Sharpness: image sharpness adjustment

#Options: High, Middle, Low.

#Default option: Low.

### 4. Gamma: adjustment of image color temperature

#Options: High, Middle, Low, Off.

#Default option: Off.

### 5. Brightness: adjustment of image brightness

### 6. Contrast: adjustment of image contrast

### 7. Hues: adjustment of image hues

### 8. Saturation: adjustment of image saturation

Adjustment of image brightness, contrast, hues and saturation:

#Select the desired item of the image adjustment section using the UP/DOWN buttons. Press OK or RIGHT key to start adjusting the relevant option.

#Change the option value using the wheel.

#Upon completion press the LEFT button of the UP/DOWN buttons to return to image setup menu.

## (4) Sound settings menu

### 1. digital audio output

a). SPDIF format: set-up of digital audio output options.

#Options: RAW, PCM.

#Default options: RAW.

#When you select the RAW option, the not decoded signal is transferred to the LCD Tv's digital outputs, the decoded signal is transferred to analog outputs. Decoding is performed by the built-in decoder of the LCD TV. This feature is meant to ensure that signal decoding at digital outputs is performed by an external device(e.g.an amplifier).

#If you select the PCM option, a PCM coded signal will be transferred to the LCD Tv's digital outputs.



### B) LPCM: set-up of digital audio output options to comply with different amplifiers and receivers.

#Options: 48kHz 16 bit, 96 Khz 24 bit.

#Default option: 48 Khz 16 bit.

### 2. Sound correction

#### A) Equalizer: equalizer modes

#Options: Off, rock, pop live sound, dance music, techno classics, soft sound.

#Default option: off.

#### B) Echo: echo effects

#Options: Off, concert, living room, hall, Bathroom, cave, arena, cathedral.

#Default option: off.

#### C) Tone balance: adjustment of tone balance level.

#Adjust the tone balance level using the cursor buttons.

#Press the LEFT button to return to sound correction set-up menu.

## (5) Playback settings

### 1. DVD

**Advertisement skip: skip the unskippable block while playing a DVD disc.**

#Options: Yes, No.

#Default option: NO.

### 2. VCD/SVCD

**PBS menu: PBC menu on/off**

#Options: On, Off.

#Default option: On.

#If On option is set, while reproducing discs, a menu will appear, in which you can select the order of playing the disc content. If the Off option is set, the reproducing of content is performed in the order, in which it is recorded on the disc.

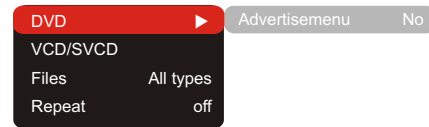

### 3. Files: selection of reproduced files on the disc

#Options: Audio, Pictures, Video, All types.

#Default option: All types.

### 4. Repeat: file repeat mode

#Options: Off, Single, All.

#Default option: Off.

## (6) Preference settings

### 1. Screensaver: screen saver on/off

#Options: On, Off.

#Default option: On.



### 2. Equalizer: spectrum analyzer

#Options: On, Off.

#Default option: Off.

## (7) Parental control settings

### 1. Category: set-up of age restrictions to prevent children from seeing undesirable discs.

#Options: Any, Kid, G, PG, PG-13, PGR, R, NC-17.

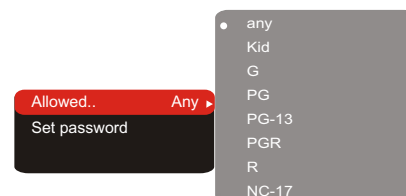

### 2. Change password: set-up of a four-digit password to change the level of age restrictions.

#Default option: 7890

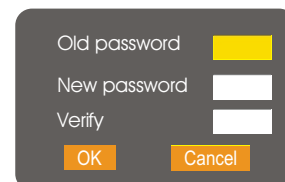

## (8) Initial setup menu

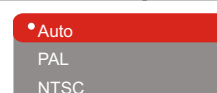

#Press the RIGHT key to enter the initial settings menu, then select the desired item using the cursor buttons and press OK key for confirmation.  
 #While being in this menu section, you cannot return to the previous level by pressing the LEFT key.

## (10) Exit settings menu

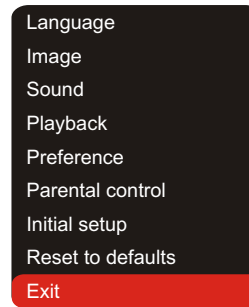

#Select the exit item using the UP/DOWN buttons and press the OK key to exit the menu.

## (9) Reset settings to default

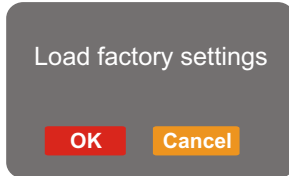

#Resetting all settings and restoring default options, except age restrictions level and password.

## 2.2.3 OTHERS

### (1) Useful notes

#To extend the service life of your LCD TV make pauses of not less than 30 seconds between switching off and repeatedly switching on the LCD TV.

#Disconnect the LCD TV from the wall outlet after shutdown.

#Some LCD TV'S functions may not be applied to some discs.

#Use supply sources of rated voltage, otherwise the LCD TV may not function or be damaged.

#In case of the LCD TV's occasional stops, please switch the power supply off and then on again.

### (2) Trouble shooting



**Please check probable causes of malfunction before addressing the service center.**

Sign of trouble	Cause of trouble	Actions to eliminate the trouble
No sound	1.Poor audio cable connection. 2.Disc dirty or damaged. 3.Sound disabled by the MUTE button.	1.Make proper connection. 2.Clean the disc. 3.Press the MUTE button.
No image	1.Poor video cable connection. 2.Incorrect settings of your TV set. 3.The TV is in the progressive scan mode while your TV set does not support this mode.	1.Make proper connection. 2.Correct the settings of your TV set. 3.Place the TV in the interlaced scan mode through the TV's menu.
Black and white image	1.incorrect TV color system selected. 2.Color level on the TV set adjusted incorrectly.	1.Set the appropriate color system via the menu: SETUP>Image>TV scan. 2.Readjust the color system of your TV set.

Discs cannot be read	1.Disc not inserted. 2.Disc inserted incorrectly. 3.Condensate on the DVD player's laser head.	1.Insert the disc. 2.Install the disc with the label side facing up. 3.Switch the TV on without disc for an hour.
Microphone does not operate	1.Microphone is unplugged. 2.Low level of the microphone's sound volume.	1.Connect the microphone. 2.Adjust the level of the microphone's sound volume.
Remote control does not operate	1.Remote control is incorrectly directed at the TV's screen. 2.Distance to the TV is in excess of 8 meters. 3.Run out batteries.	1.Use the remote control according to the manual. 2.Decrease the distance to the TV. 3.Replace both batteries.
some functions do not work	1.Disc is recorded incorrectly. 2.Incorrect key sequence. 3.Static voltage on the housing.	1.Wait 5-10 seconds and the device will automatically return to normal state. 2.Repeat the operation one more time. 3.Switch the device off for 1-2 min
Unstable image	1.Incorrect TV set settings.	1.Correct the TV set settings.

### (3) Technical characteristics

		LD1506SI	LD1906SI	LD2006SI
Display	Type class	TFT, colored II(ISO 13406-2)		
	Size(") Height(mm) Width(mm)	15 228.19 304.13 0.297×0.297	19 256.5 410.4 0.285×0.285	20/50,8 306 408 0,707×0,707
Frequency	Vertical(Hz) Horizontal(kHz) Display color	50-75 30-75 16 700		
Maximum Display Mode	Resolution Vertical frequency(Hz)	1024×768 75	1440×900 75	640×480 75
Inputs	Video	1	1	
	Composite	1	1	1
	Component	1	1	1
	VGA	1	1	-
	RGB/SCART			1
	Audio	2	2	
	Stereo	1	1	2
	PC audio			-
Others	2	2		
USB	1	1	2	
RF			1	
Audio outputs	Headphone	1	1	1
	Digital coaxial	1	1	1

Color system	TV tuner Video inputs	PAL,SECAM PAL, SECAM, NTSC 3.58, NTSC 4.43,PAL60		
Sound system	TV tuner	DK,I,BG,L		
Built-in DVD player	Disc types	CD-R/RW,DVD-R/RW ,DVD+R/RW		
	Formats	DVD-Video,DivX,XviD,SVCD,VCD,CD-DA,HDCD,MP3,WMA,Kodak Picture CD,JPEG		
Power adapter	Voltage and frequency(V,Hz) Voltage of external(V,A)	~100-240,50/60		
		 :+12	 :+12	-
Power supply	Power Consumption (Maximum)(w)	54		65
	Power Consumption (Power Saving)(w)	<3		<3
Environmental consideration	Operating temperature(°C)	+5...+35		10-80
	Operating humidity(%) Storing temperature (°C) Storing humidity(%)	-20...+45		
Dimensions(mm)		438.7×295.7×73.4	498×370.6×82.5	620×450×202
Weight	Net weight(kg)	6.5	7.1	8.1

#We are permanently improving the quality of our products; hence the product's design, functionality and technical characteristics may be modified without prior notice.

#We do not guarantee that all discs can be played smoothly due to the disc quality, disc recording quality and recording format.

# Chapter Three Principle and Servicing

## The previous manual: TV part

### Section One Principle of the player

#### 3.1.1 Function

LD2006SI is a 20" LCD\_TV with multiple functions, such as DVD playing and USB reading function. Electronic scheme of TV part adopts 20" TFT display screen+inverter components (INV604)+MST718+STV8216 +TDA7266P+ tuner JS -6H2/T121. MST718 includes MCU/video A/D converter/LCD image processing circuit. DVD part electronic scheme adopts MT1389HD+64M SDRAM+16M FLASH+D5954. HD62 loader can smoothly read MPEG4/MP3/CD/DVD format discs and decode chip MT1389HD may support USB and card read function.

# Digital picture adjustment technology to adjust sharpness, brightness, contrast, hue and saturation of pictures; gamma correction.

# Video circuit supports PAL/NTSC/SECAM/PAL60 multi-system video signals.

# Support USB/card read function.

# Compatible with DIVX, MPEG4 format film.

# Support PAL BG/DK/I, SECAM BG/DK/L/L' RF signal modulating.

#### 3.1.2 Block diagram of the player

3.1.2.1 This machine is mainly composed of the following PCB semi-finished products and display screen components. Please refer to model list for allocation of the player:

1. Main video board (21903-4): this PCB semi-finished product is the main part of the player. Main video board includes audio/video input circuit, audio selecting and amplifying circuit, video selecting and LCD drive circuit, DVD decode and servo circuit. The main function is to fulfill audio/video signals' processing and DVD function's fulfilment.

2. Power board (@52006-0UL): power board is mainly composed of rectifying circuit and filtering circuit. This PCB semi-finished product's main function is to provide the player with working power.

3. Inverter components (INV607): inverter components are mainly composed of boost circuit and protection circuit. This PCB semi-finished product's function is to provide display screen components with lamp working voltage.

4. Remote control receiving board (B1903-1): this semi-finished product is composed of one IR sensor and working indicator light. This PCB semi-finished product's main function is receive the control order that sends from remote controller and transmit to MCU part of main video board to control the working state indication of the player.

5. TV button board 41903-0/DVD button board J1903-0: mainly composed of buttons which are responsible for the function control of TV part and DVD part.

6. USB board D1903-1: this PCB semi-finished product includes USB jack circuit and it is mainly responsible for USB read function.

7. Display screen components: include LCD display screen, lamp, LCD screen drive circuit and jack circuit. The main function is to revert video signals to image to supply for clients to enjoy video images.

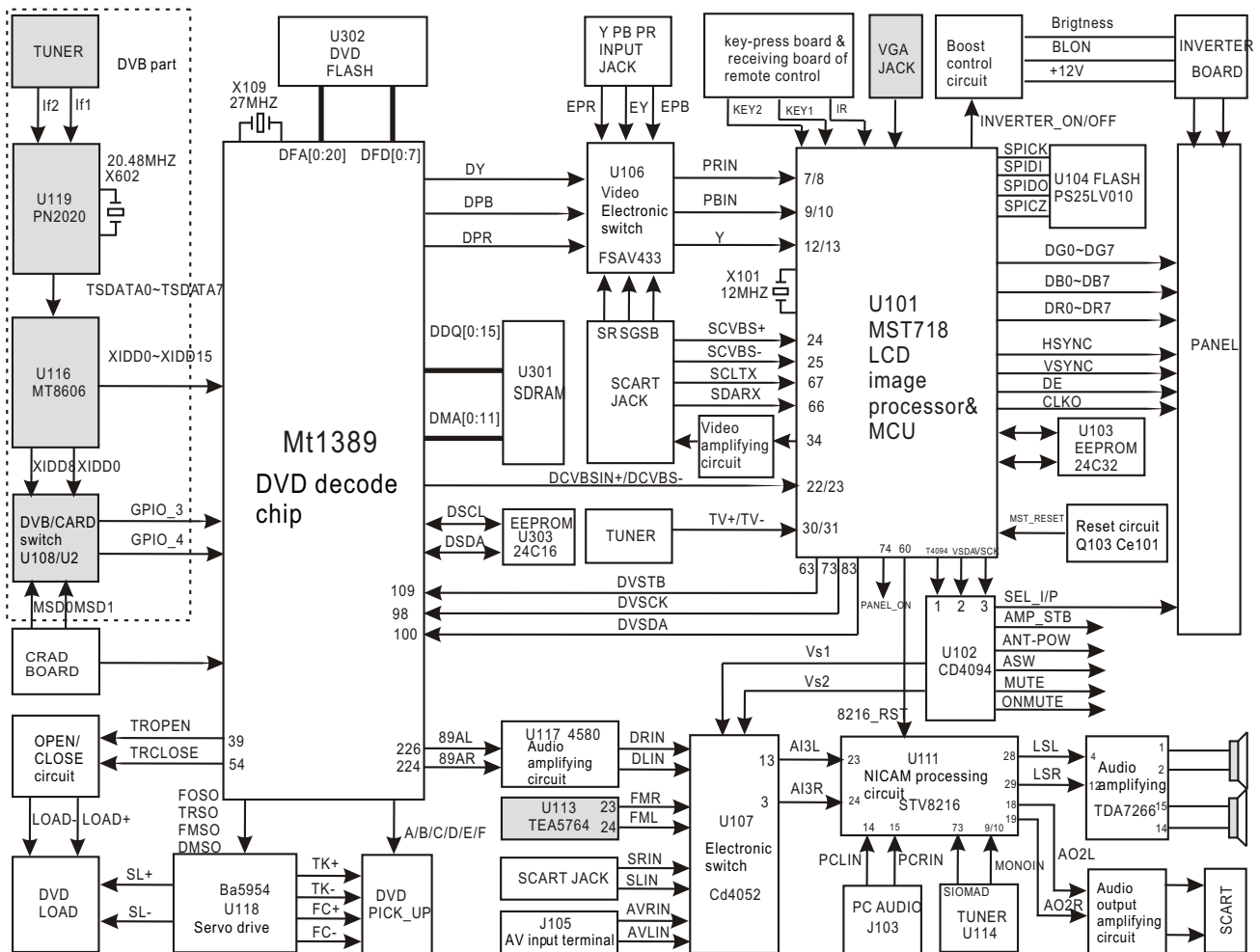

figure 3.1.2.1 Block diagram of the player

Annotate: 3.1.2.1 Block diagram explanation: this machine is divided to 3 parts according to functional module.

1. TV part: according to design demands, TV part mainly includes LCD image processing, audio processing and amplifying circuit, MCU control circuit.

2. According to design demands, DVD part mainly includes decode circuit and servo circuit.

3. DVB circuit: DVB circuit mainly includes channel decoder and TS decoder. This machine does not use this function, to facilitate understanding, so we use gray colour to mark the unused part in the block diagram.

### 3.1.3 Function introduction to IC of the player

Function introduction to IC of the player is shown as in the following figure:

SN	Material code	Material name	Specs & Model	Qty	Position Number	Function
1	790021	FET	IRF7416 SOP	1	U511	(+)12V switch control pipe
2	883191	IC	TDA7266SA ZIP	1	U112	Audio amplifying IC
3	882030	IC	STV8216 TQFP	1	U111	NICAM processing IC
4	883189	IC	MST718BE PQFP	1	U101	LCD image processing&CPU
5	883323	IC	AP1506Adj TO263-5L	2	U503,U506	(+)5V voltage stabilizing IC
6	882953	IC	K4S641632K-UC60 TSOP	1	U301	SDRAM
7	882076	IC	LM1085-3.3 SOT-263	1	U521	DV33 voltage stabilizing IC
8	882883	IC	FSAV433 TSSOP	1	U106	Components video selection IC
9	790126	SMD FET	FDS9435A SOP	1	U502	Display screen power control pipe
10	880504	IC	24C32N SOP	1	U103	TV EEPROM
11	882756	IC	HEF4094BT SOP	1	U102	Serial/parallel converter
12	882515	IC	HEF4052BT SOP	1	U107	Sound source selecting electronic switch
13	882485	IC	AZ1117H-3.3 SOT-223	2	U505,U513	3.3V voltage stabilizing IC
14	883245	IC	AZ1085S-2.5Z TO-263	1	U507	2.5V voltage stabilizing IC
15	882121	IC	AK18 SOT-223	1	U1	1.8V voltage stabilizing IC
16	1020094	Tuner	JS-6H2/T121	1	U114	Receive TV signal
17	900458	Software program	ROMLD2006SI2-0A(2M)	1	U104	TV software program



## Section Two Unit Circuit Principle

### 3.2.1 System control circuit

System control circuit is mainly composed of reset circuit, clock circuit, serial/parallel conversion circuit, software program, EEPROM and MCU (MST718 is built inside). The built-in MCU of MST718 is mainly responsible for the coordination and control of system of the player. This MCU is connected with a 2M ROM externally, which is used to store software and control function of the player. Since I/O port of MST718 is limited, a serial/parallel conversion circuit (CD4094) is added to extend I/O port. Functions may be adjusted through software. MST718 is connected with a 32k EEPROM externally, used to store user-set information.

#### 1. System reset circuit

(1) system reset circuit is shown in the figure 3.2.1.1:

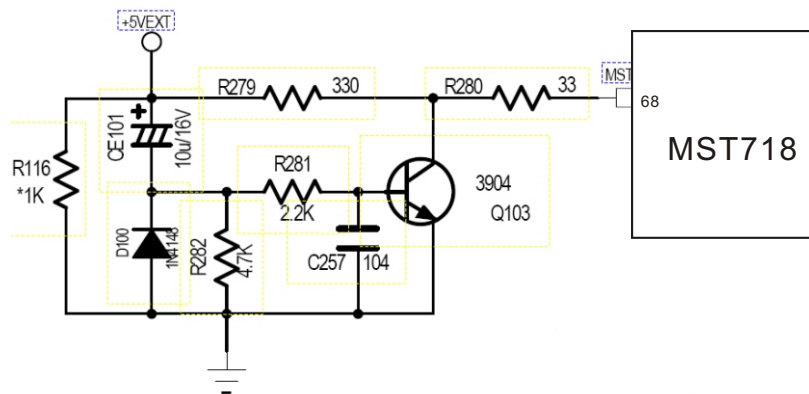

Figure 3.2.1.1 System reset circuit diagram

(2) Working principle: this circuit is a typical low level effective reset circuit. After power on, “+5V EXT” changes from 0V to 5V, and charge R282 through CE101. Voltage of two ends of CE101 cannot change suddenly, now Q103 is saturated on, C-E electrode is connected, MST RESET is low level to provide pin 68 of U101 with a low level reset signal to reset MST718. After capacitor CE101 is fully charged, voltage on two ends is near to 5V, now Q103 cuts off, voltage of pin 68 of MST718 restores to high level to finish reset action. Reset time of this circuit is about 100MS, which is decided by the value of R282 and CE101. Function of D100 is to discharge CE101 quickly to ensure the reliable reset when power on for the second time. The trouble that appears in this circuit is that machine cannot enter standby state after power on, and machine fault after power on.

## 2. System clock circuit

(1) System clock circuit is shown in the figure 3.2.1.2:

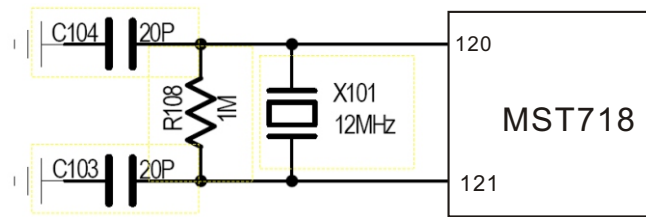

Figure 3.2.1.2 System clock circuit

(2) Working principle: this clock circuit is mainly composed of X101, C104 and C103, in which X101 is a 12MHz crystal oscillator; C104 and C103 are externally-connected resonance capacitors to produce a 12MHz clock signal to provide for MST718 to generate clock signal required by system through internal doubling circuit to act as working clock.

## 3. System control principle

(1) System control schematic diagram is shown in the figure 3.2.1.3:

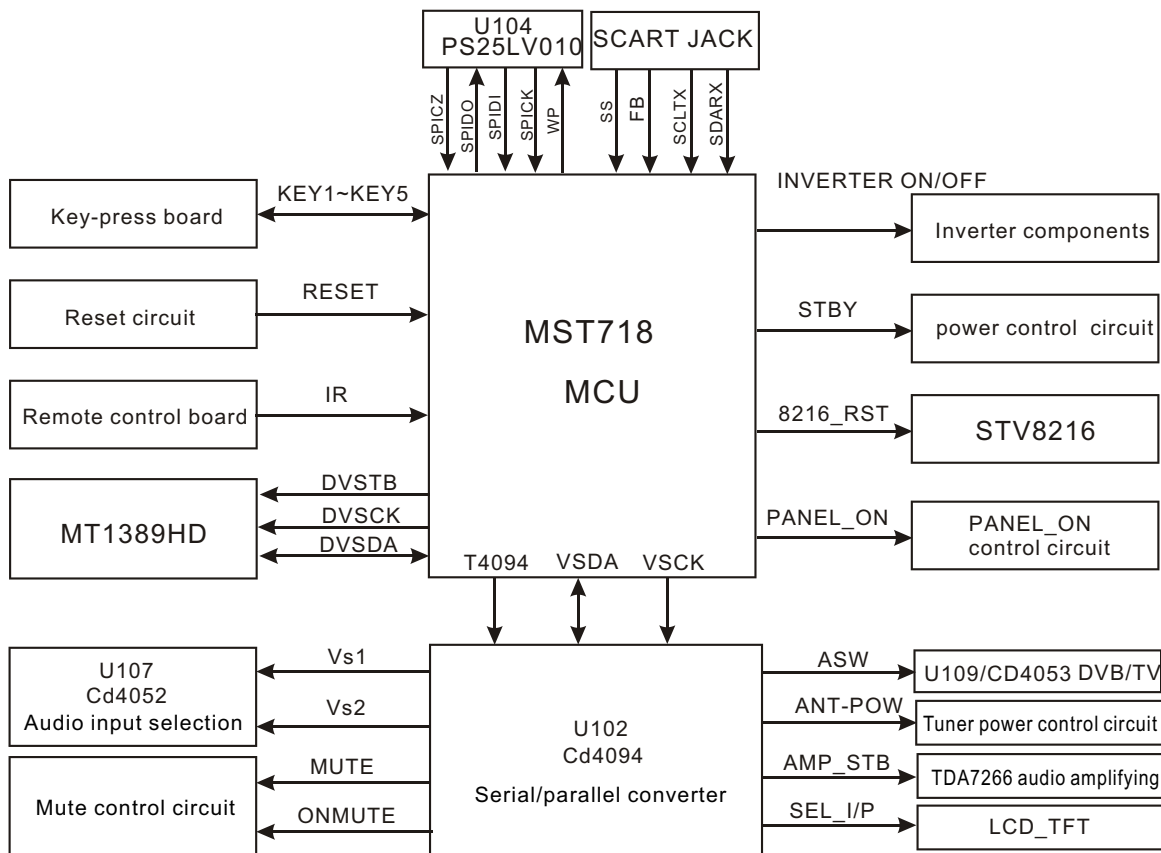

Figure 3.2.1.3 System control schematic diagram

## (2) Working principle

System control circuit of the player is composed of the built-in MCU of MST718 and software Program. Machine power on: after 12V power is being rectified by U503, +5V power outputs to provide for system control circuit. The reset circuit of system control circuit begins to reset MST718, the red indicator light on remote control receiving board is on under the control of STBY signal (high level), and this means machine enters standby state.

The process from standby state to power on state: after pressing POWER button on panel or wake code on remote controller, pin 57 of MST718 changes from high level to low level, pin STBY outputs a low level signal to make Q117 cutoff, /STBY skips to high level, STBY is divided to 3 parts: +5V power control circuit composed of Q3/U506; +12V power control circuit composed of Q117/U511 and standby indication circuit on remote control receiving board. Power supply of machine is normal, MST718 begins to output reset and other control signal (please refer to waveform diagram for sequence of each control signal output) to reset and control circuit of other module to make machine enter normal working state.

The process from working state to standby state: when machine is in power-on state, after pressing POWER button on panel or wake code on remote controller again, machine enters from power-on to standby, now pin 57 of MST718 outputs high level, /STBY pin output low level, +5V power and +12V power of machine are cut off and machine enters standby state.

## 4. IIC bus control circuit

(1) IIC bus control circuit block diagram is shown in the figure 3.2.1.4:

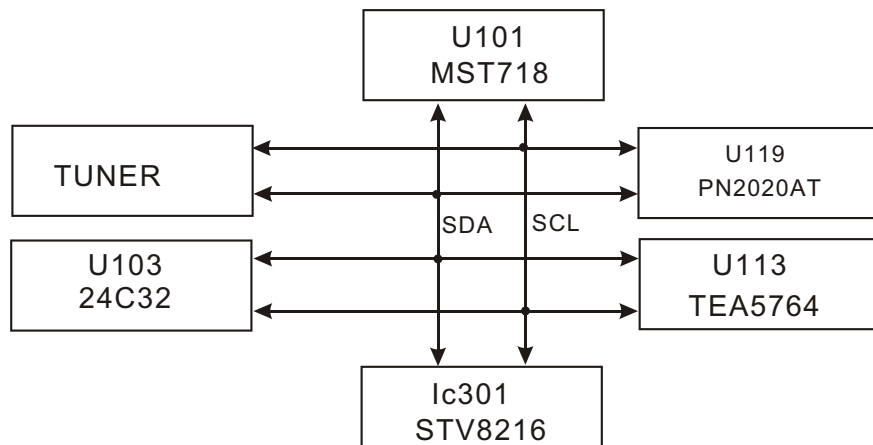

Figure 3.2.1.4 IC bus control circuit block diagram

(2) Working principle: IIC bus is a kind of simple, dual-direction and synchronous serial line developed by PHILIPS company. Only 2 lines (serial clock line and serial data line) are required to connect between components on bus to transmit information. This bus is high-performance serial bus which has function of decision and synchrony of high and low speed devices required by multi-player system with wide application range. shown in the figure 3.2.1.4, U103 is a 32K memorizer used to store user information.

## 5. Serial/parallel conversion circuit

(1) Serial/parallel conversion circuit is shown in the figure 3.2.1.5:

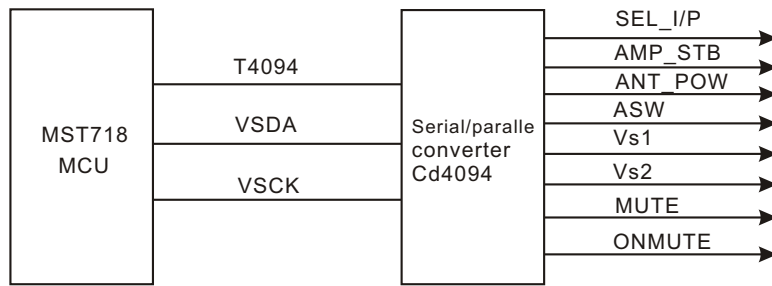

Figure 3.2.1.5 Serial/parallel conversion circuit

(2) Working principle:

Because jack of MST718 is limited, in order to extend control port, a serial/parallel converter (CD4094) is added in MCU peripheral. CD4094 is a serial in/parallel out high speed converter with output latch and 3-mode control and its advantages are easy usage, low power consumption, strong drive and flexible control. {1} pin is latch end, {2} pin is serial data input end, {3} pin is serial clock end. When {1} pin is high level, the increase of 8-bit parallel output port Q1~Q8 changes with serial input; when {1} pin is low level, output is locked. Using latch end may conveniently perform chip selection and output control. {15} pin is parallel output state control end, when {15} pin is low level, parallel output end is in high resistance state; when using CD4094 as display output, the display number may flicker. QS of pin {9} and Q'S of pin {10} are serial data output end. Control signals after conversion are used in control mute circuit/sound source selection circuit.

## 6. Working state indication circuit

(1) Working state indication circuit is shown in the figure 3.2.1.6:

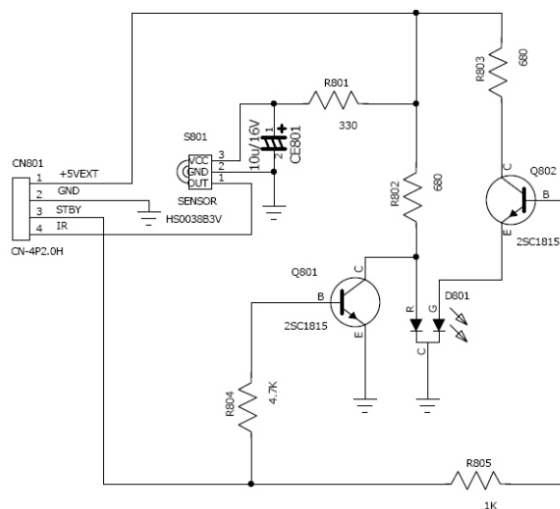

Figure 3.2.1.6 Working state indication circuit diagram

(2) Working principle: when machine is in standby state, pin 57 of MST718 outputs high level signal. To make standby control circuit \STBY signal outputs low level signal. This signal is directly connected to pin 3 of remote control receiving board flat cable holder Cn801. This control signal inputs to base electrode of Q801/Q802 through R804/R805 to make Q802 cutoff, Q801 is connected, the red light of bi-color diode D801 is on, which means that machine enters standby state. After pressing POWER button, machine enters working state, pin 3 of ,Cn801 outputs high level to make Q802 on/Q801 cutoff, the green light of b-icolor D801 is on, which means machines enters working state. S801 is IR sensor to receive remote control signals mainly.

### 3.2.2 Audio circuit

Audio processing circuit is mainly responsible for the switch, amplifying and restore of audio and composed of audio source input selection and NICAM processing circuit, audio amplifying circuit and mute control circuit. Audio processing circuit block diagram is shown in the figure 3.2.2.1:

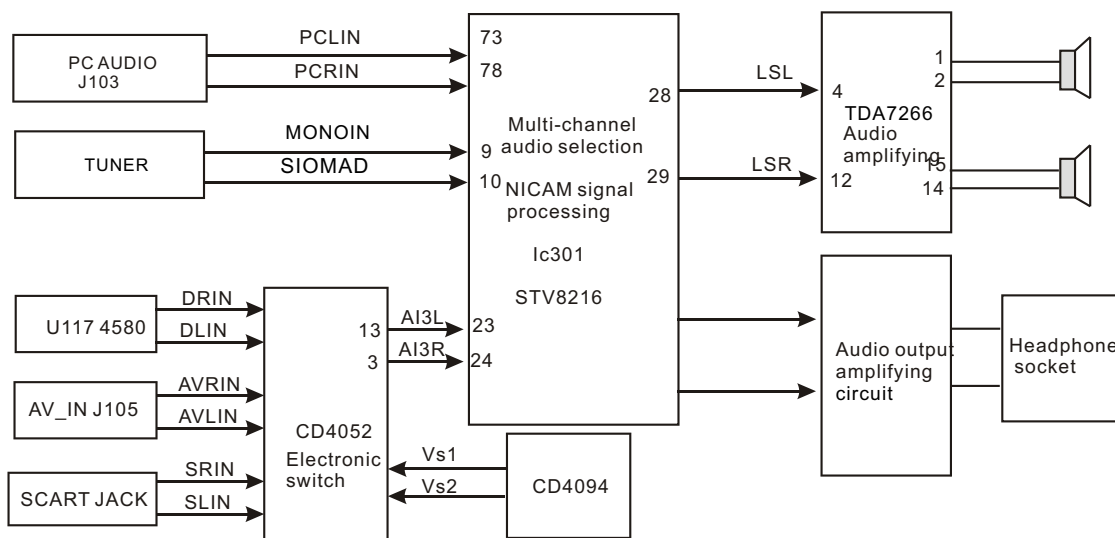

Figure 3.2.2.1 Audio processing circuit block diagram

#### 1. "Nicom" processing circuit

(1) NICAM: the core technology of "NICAM" is the NICAM728 technology developed by BBC. Besides transmitting TV image and simulating mono-channel signal, NICAM TV broadcasting system also transmits dual-channel digital coding sound signal. NICAM is famous for clear treble and deep bass with the sound quality close to listening to CD disk directly. In the aspect of SNR, dynamic range and channel separation index, NICAM is far better than the current FM accompany. As TV accompany, NICAM applies 3 kinds of working mode currently: 1) Bilingual mode: NICAM transmits dual-channel digital sound relevant or irrelevant to the current program and transmits 3-channel sound signal together with

The original FM analog accompany, which are suitable for multi-language areas; 2) Stereo mode: two digital channels of NICAM transmit left and right channel sound signals of stereo separately, and the original FM analog accompany only transmits mixed sound signals of 2 channels to be compatible with TV set without NICAM function; 3) Mon0-channel mode: two channels of NICAM transmit one channel sound signals and one channel data signal, which is equal to providing 3-channel signals together with the original TV analog accompany.

(2) "NICAM" processing circuit: when tuner receives NICAM signal, it outputs from pin 11 of tuner (SIOMAD), and inputs into pin 73 of STV8216 through the filtering circuit composed of C301, C302 components and then restores to audio signal through being modulated by internal circuit of STV8216 and sends to audio amplifying circuit through pin 28, 29 of STV8216. STV8216 block diagram is shown in the figure 3.2.2.2:

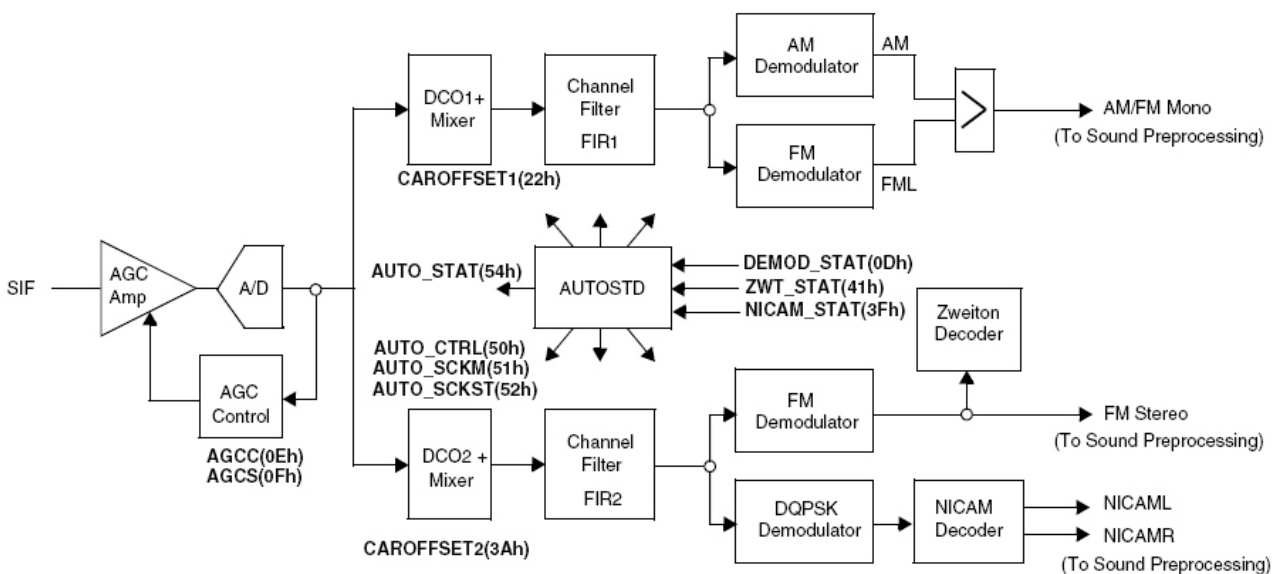

Figure 3.2.2.2 STV8216 internal block diagram

## 2. Sound source input selection circuit

Besides NICAM processing circuit, STV8216 also includes multi-channel sound source selection function. After the machine enters from standby to power-on, systems sends a low level effective reset signal to pin 43 of STV8216 to reset STV8216. IIC bus means is adopted between STV8216 and MST718 for communication. When system working state is set in SCART input, Cd4052 outputs SCART signal under the control of MST718 and then input to STV8216, now pin 23, 24 of STV8216 output the audio signals inputted by SCART\_IN and also output two groups of audio signals as external output signal through pin 18, 19. Working principle of other groups' sound source input is the same, so we will not introduce here.

External input sources of this player are many and input port of STV8216 cannot meet the demands, so a CD is added in front of STV8216 to switch in DVD\_AUDIO/external input terminal and SCART AUDIO input port.

### 3. Audio amplifying circuit

(1) Audio amplifying circuit is shown in the figure 3.2.2.3:

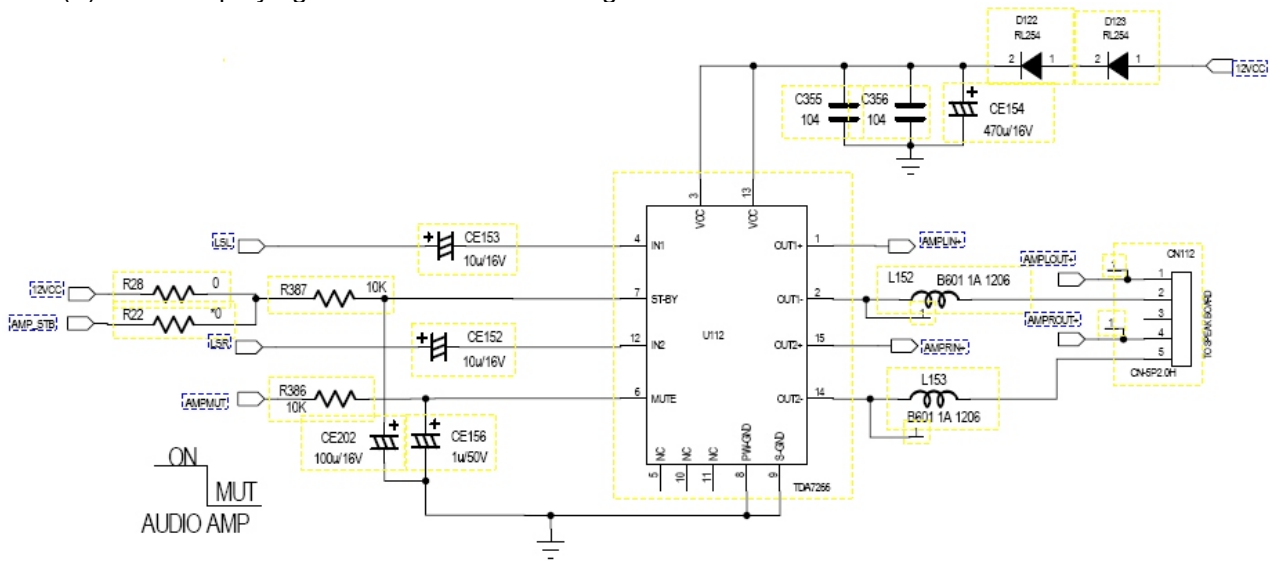

Figure 3.2.2.3 Audio amplifying circuit diagram

(2) Working principle: TDA7266P is a 3W+3W dual-bridge audio amplifying. Audio signals input through pin 4, 12 of TDA7266 and then output from pin 1, 2, 14, 15 of TDA7266P after being amplified by internal dual-bridge audio amplifier to drive loudspeaker to make sounds. This IC adopts +10V power supply, D122/D123 is drop diode and pin 7 is standby control pin. After machine enters power-on state, pin 12 of cd4094 (AMP\_STB) outputs high level and this IC enters working mode. This player adopts default high level mode, so R22 is not used, but R28 is adopted to connect onto power. Pin 6 is mute and controlled by mute circuit.

### 4. Mute control circuit

(1) Mute control circuit is shown in the figure 3.2.2.4:

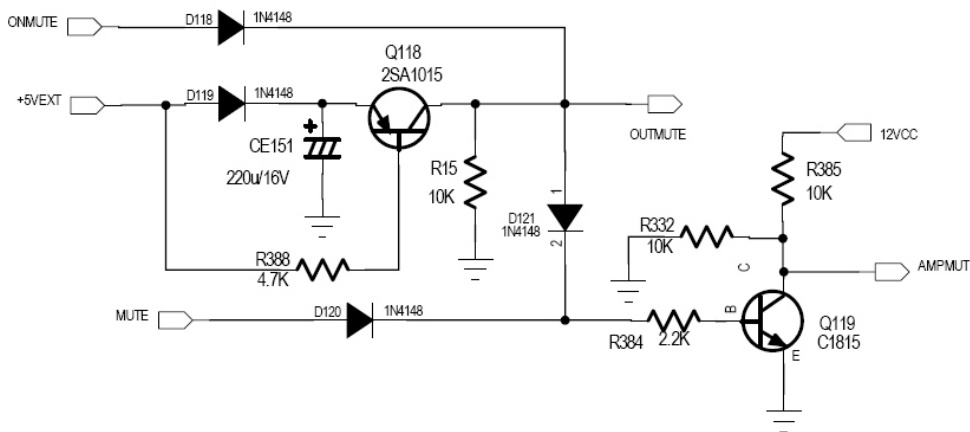

Figure 3.2.2.4 Mute circuit diagram

## (2) Working principle

Power-on mute: after power on, machine enters from standby to power on. Because of R28, pin 11 of TDA7266 is low level, now ONMUTE pin of Cd4094 outputs high level signal, OUTMUTE is high level, Q113/Q112/Q119 is saturated on, machine enters mute state to realize power-on mute effect. After machine starts up, ONMUTE switches to low level, Q113/Q112/Q119 cuts off to make pin 6 of TDA7266 high level, TDA7266 enters non-mute mode, the player has sound output and power-on mute fulfills.

Power-off mute: when machines enters standby mode from working state, ONMUTE pin outputs high level, OUTMUTE pin is high level signal, TDA7266 enters mute state.

Power failure mute: when power of machine is switched off, Ce151 has been fully charged when power on, after machine power switches off, Ce151 discharges through Q118/D121 to make Q119 connected, now pin 6 of TDA7266 is low level to realize power-off mute function.

When user use remote controller to mute the machine, MUTE pin outputs high level signal to make Q119 saturated on, pin 6 of TDA7266 is low level and TDA7266 enters mute mode.

## (3) SCART Audio output amplifying circuit:

SCART Audio output amplifying circuit is shown in the figure 3.2.2.5:

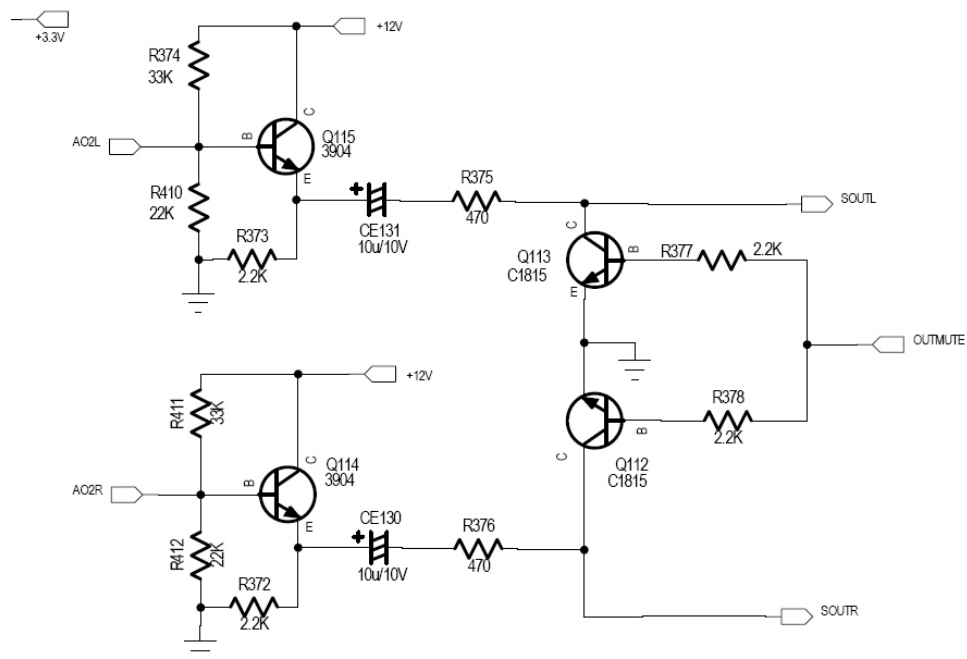

Figure 3.2.2.5 SCART Audio output amplifying circuit diagram

Working principle: the picture is an amplifying circuit composed of triode, mainly used in audio output amplifying. Q114/Q115 in the picture is amplifying pipe, CE131/CE130 is blocking capacitor, Q113/Q112 is mute pipe which is used for power on/off mute. Audio signals outputted by this circuit are used for SCART output.



### 3.2.3 Video circuit

Video circuit is mainly responsible for the input of external video signals, the processing of video signals send from tuner, and the drive processing of LCD screen, including video input selection, video A/D conversion circuit, LCD picture processing circuit and video output circuit. Video circuit block diagram is shown in the figure 3.2.3.1:

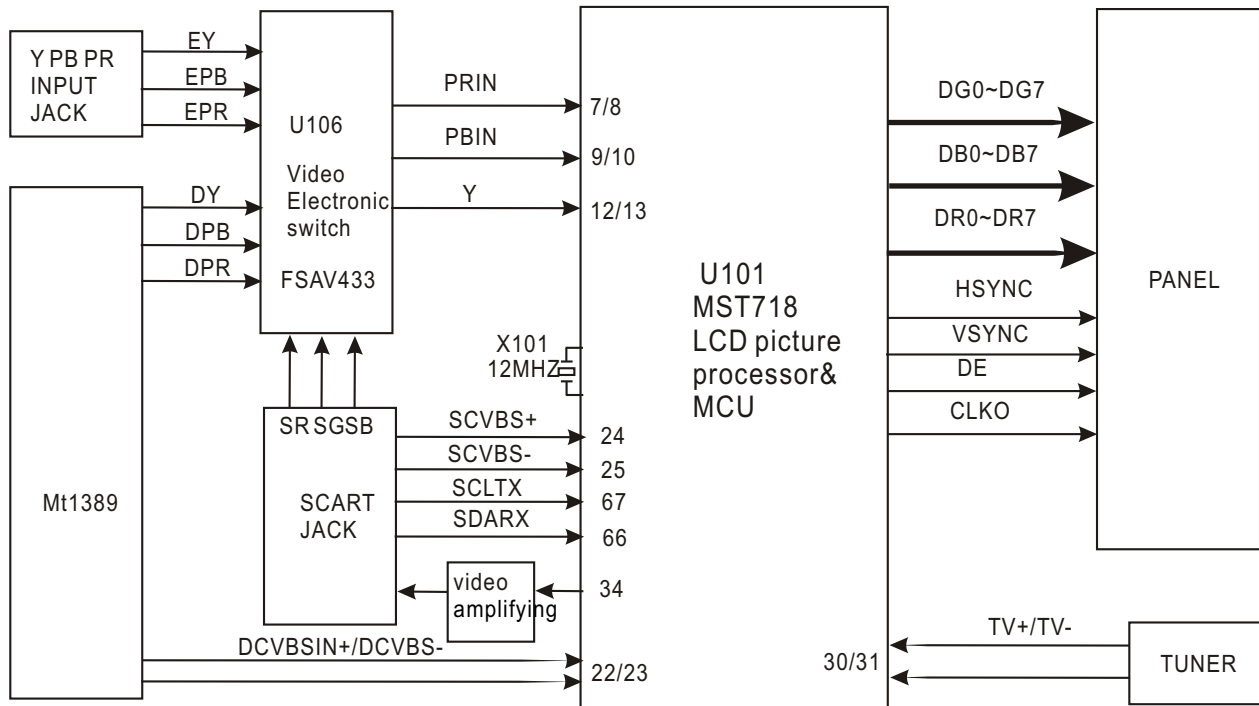

Figure 3.2.3.1 Video circuit block diagram

#### 1. Video input and video processing circuit

This circuit is mainly composed of FSAV433 and MST718, MST718 supports NTSC, PAL and SECAM video signals and the supportable video signal format has RGB, YPbPr, CVBS or S-video video. The built-in A/D converter can realize multi-format's conversion function. MST718 adds video switch, A/D converter and MCU on the basis of MST518 and MST718 also has video output function. Output jack includes TTL, LVDS modes.

When machine is set in DVD or DVB mode, Y PB Pr signal is inputted to pin 2/6/10 of FSAV433, and then output from pin 13/15/17 after being selected through electronic switch (FSAV433) to MST718 for A/D conversion. At the same time, Mt1389 also outputs composite video signal, after being selected through the internal video electronic switch of MST718, output from pin 34 of MST718 to the video amplifying circuit composed of Q100, Q1 and then output to SCART video output pin.

## 2. LCD image processing circuit

LCD image processing circuit is composed of MST7187 And peripheral elements, Responsible for switching the exterior inputted analog video signals into signals required by LCD drive.

MST518 is a high-performance and high integration picture processing chip designed for LCD, which can support SXGA format. multi-format output display jack (support TTL, LVDS, RSDS). This player adopts analog signal, MST718 built-in MCU, MST518VA has multi-format output display jack. TTL output means is adopted in this player and the output means can be adjusted through software according to screen's drive means. MST718 outputs DR0~DR7/DG0~DG7/DB0~DB7 to drive display screen, and also outputs clock, enable and synchronous signals to supply for the working of screen (770 OCLK clock output, 78 DE enable signal, 79 VSYNC filed synchronous output and 80 HSYNC line synchronous output).

## 3.2.4 Input circuit

External input means of TV has SCART\CVBS and Y/PB/PR, and also composite video and stereo audio output function.

### 1. Introduction to SCART terminal :

SCART terminal is a standard input port in Europe. In this jack circuit, many dual-direction diodes are adopted and act as protection function to prevent the instability of externally-connected device or damage of the machine due to static. SCART pin function is shown in the following table:

Pin	Name	Signal direction	Function description	Pin	Name	Signal direction	Function description
1	A(B)OUT	I	Audio right channel input	12	NC		Network communication data line 2
2	A(B)IN	O	Audio right channel output	13	RETURN		Pr signal ground
3	A(A)OUT	I	Audio left channel input	14	RETURN		Blanking signal ground
4	A-COM		Audio signal ground	15	RED I/O	I/O	Pr signal I/O port
5	RETURN		Pb signal ground	16	BLK I/O	I/O	Blanking signal I/O port ★
6	A(A)IN	O	Audio left channel output	17	RETURN		Blanking signal ground
7	BLUE I/O	I/O	Pb signal I/O port	18	TRTURN		Composite video signal ground
8	FUNCSW	I	Function selection jack	19	V-OUT	I	Composite video signal input
9	RETURN		Y1 signal ground	20	V-IN	O	Composite video signal output
10	CONT	I/O	Network communication data line 2	21	GND		Common
11	GREEN I/O	I/O	Y1 signal I/O port				

## 2. TV Tuner circuit

(1) Tuner circuit is shown in the figure 3.2.4.1:

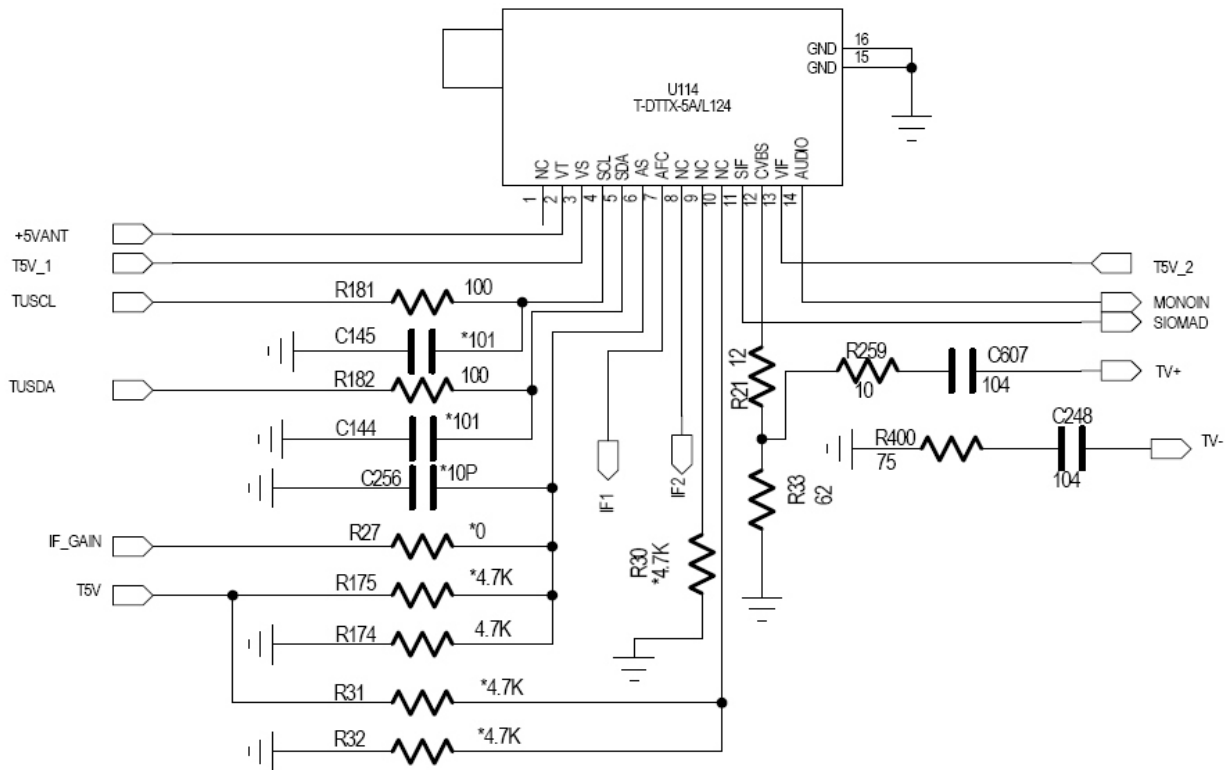

Figure 3.2.4.1 Tuner circuit diagram

(2) Working principle: this tuner includes middle frequency amplifying circuit, which adopts IIC bus means to perform function control (such as select channel and search channel) through MST718 built-in MCU. After high frequency signals are modulated, video signals and audio signals are separated through being filtered by internal filter of tuner. Audio and video signals output from pin 12, 14 and then send to audio and video processing circuit. When tuner receives NICAM signal, NICAM signals output From pin 11 of tuner to STV8216 for modulating.

(3) Tuner pin function is shown in the following table:

Pin	Name	Function	Pin	Name	Function
1	NC	NC	8	NC	DVB input jack is unus ed
2	VT	Connect with external power	9	NC	NC
3	VS	(+)5V power supply pin	10	NC	NC
4	SCL	SCLis connected with MCU	11	SIF	SIOMAD
5	SDA	SDA is connected with MCU	12	TUNER_CVBS	Video output
6	AS	AGC control end is unused	13	VIF	5V power is connected externally
7	AFC	DVB input jack is unus ed	14	AUDIO	Audio output

### 3.2.5 Power circuit

#### 1. Power circuit block diagram

(1) Power circuit supplies stable and pure power for each unit circuit to ensure normal working of the player. Power circuit block diagram is shown in the figure 3.2.5.1:

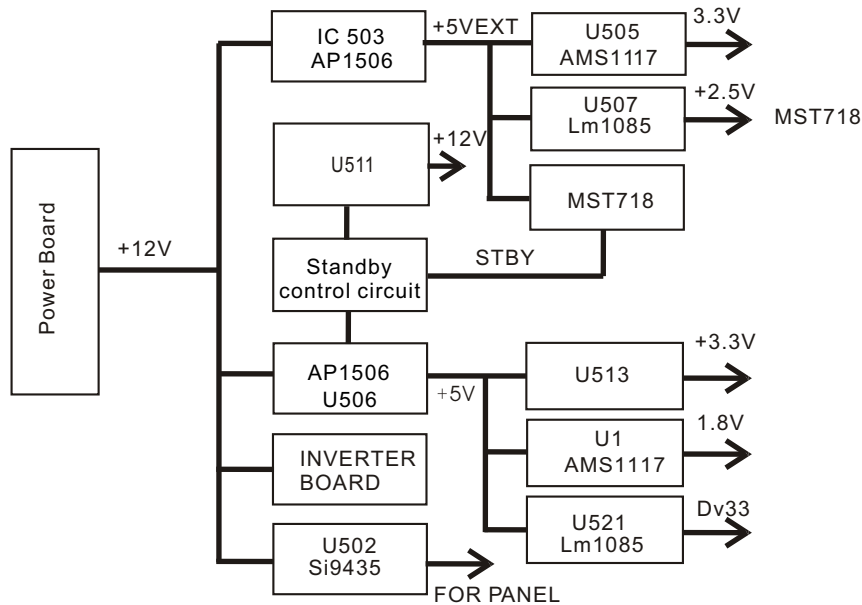

Figure 3.2.5.1 Power circuit block diagram

(2) Working principle: after AC power is being rectified and filtered through power board, 12V power outputs. This power is inputted to voltage stabilizing circuit of video main board through socket Cn6 for voltage stabilizing. The power outputted after being voltage stabilized is working power of each circuit. Voltage stabilizing circuit on video main board is divided to 3 parts: 1) +5VEXT outputted after being voltage stabilized by Ic503 is mainly supplied for system control circuit; 2) +5V power outputted after being voltage stabilized by is mainly supplied for DVD/DVB circuit; 3) +12V voltage stabilizing and control circuit supply working voltage for rear audio circuit.

(3) Introduction to each functional module in the picture: U502 is display screen power control pipe, controlled by PANELON signal outputted by MST718; U511 is 12V power control pipe; U505/U507 is voltage stabilizing IC, which supplies working power for MST718; U516/U1/U521 is voltage stabilizing IC and voltage outputted after voltage stabilizing is supplied for DVD circuit. Please refer to the following part “Principle analysis” for working principle.

#### 2. +5VEXT Voltage stabilizing circuit and display screen Power control circuit

(1) +5VEXT Voltage stabilizing circuit and display screen Power control circuit diagram is shown in the figure 3.2.5.3:

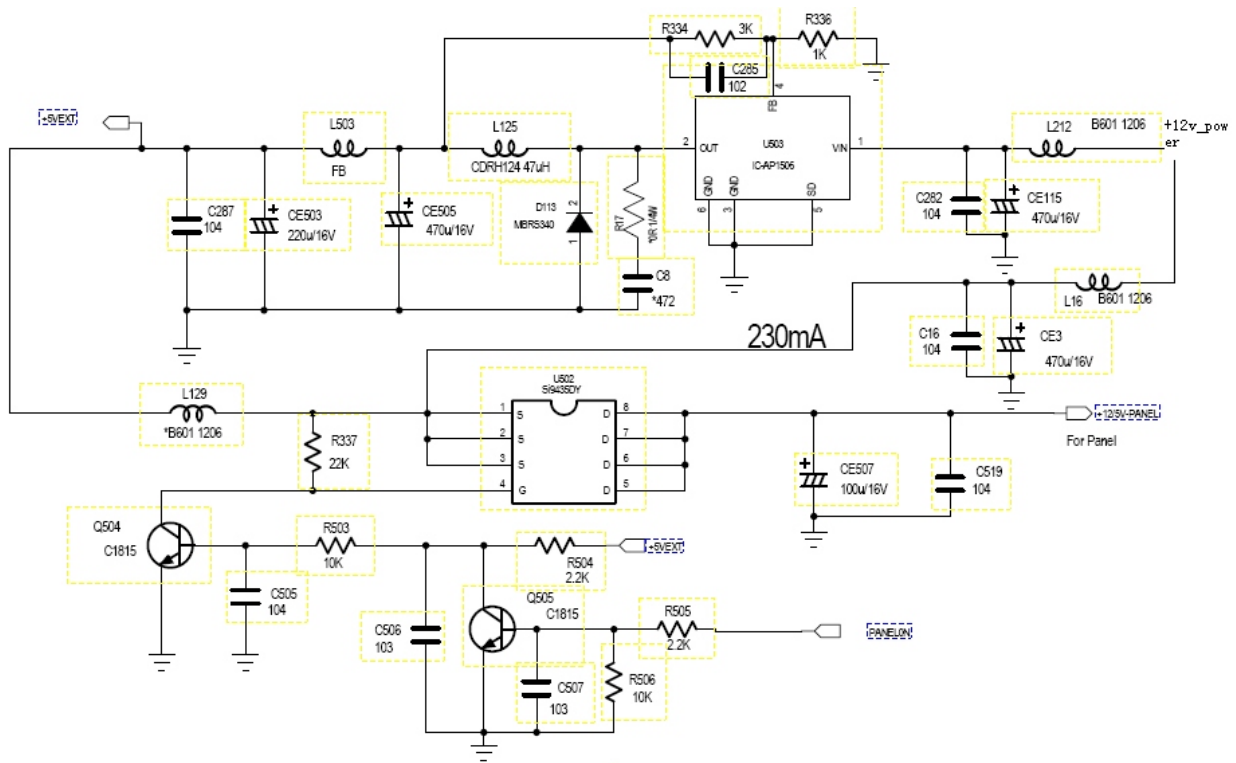

Figure 3.2.5.3 Voltage stabilizing circuit and display screen Power control circuit diagram

(2) Working principle:

+5VEXT voltage stabilizing circuit: after the AC power inputted externally is being rectified/filtered through power board, +12V power inputs to main video board. +12V power is divided to multi-group power supply. One group inputs to the +5V voltage stabilizing circuit composed by U503 (Ap1506) (Ap1506 is a voltage drop type voltage stabilizing IC), after the 12V power inputted by power board is being voltage stabilized through Ap1506, +5V power outputs directly. Pin 4 of Ap1506 is feedback end and the resistance of its externally-connected resistor may adjust the output voltage. To facilitate to differentiate +5VEXT mark ion circuit, this group of power is mainly used for MST718 and each control circuit and supply working power for the player when in standby working state.

Display screen working power control circuit: display screen power has +5V/+12V. Display screen of this player adopts +12V power supply, so L219 is not used in circuit but L16 is used for power supply. U502 in the picture is a MOS pipe used for switch function to control power supply of display screen. This MOS pipe is controlled by PANELON signal. When machine is in standby, PANELON outputs high level signal and U502 cuts off.

After machine power on, pin 74 of MST718 outputs low level signal to make Q505 cutoff, Q504/U502 is connected, +12V power outputs to display screen through U502 and display screen begins to work.

### 3. +12V Power control circuit

(1)+12V Power control circuit diagram is shown in the figure3.2.5.4:

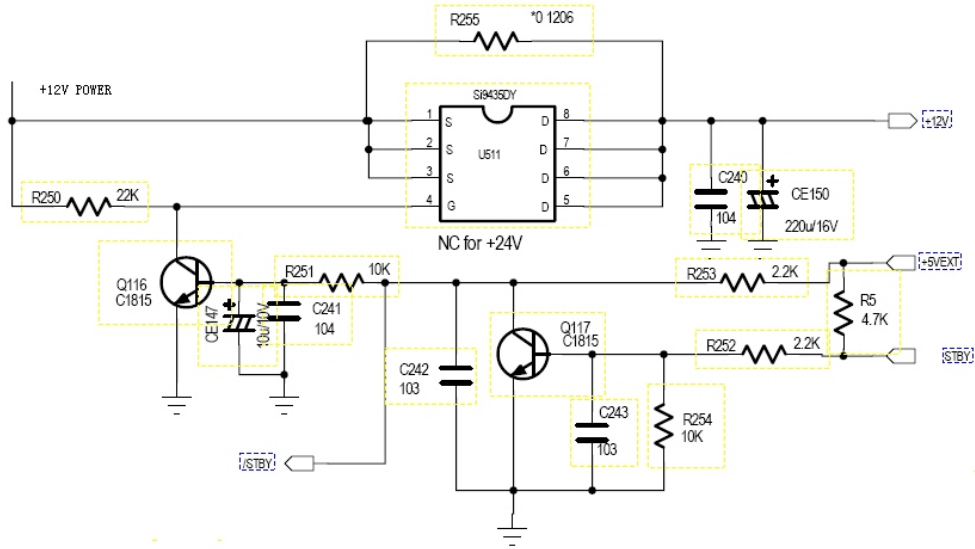

Figure 3.2.5.4 +12V Power control circuit diagram

(2) Working principle: this +12V power is mainly used in audio circuit. When in standby working state, STBY is high level, Q117 is connected, Q116/U511 cuts off, 12V power cannot pass through S-D electrode of U511 and cannot supply power for audio circuit and audio circuit cannot work. After machine enters power-on from standby, STBY becomes low level, Q117 cuts off to make Q116/U511 connected, power inputs to audio circuit through U511S-D electrode and audio circuit begins to work.

### 4. MST718 working power voltage stabilizing circuit

(1) +2.5v/3.3V voltage stabilizing circuit

3.3V voltage stabilizing circuit is shown in the figure 3.2.5.4:

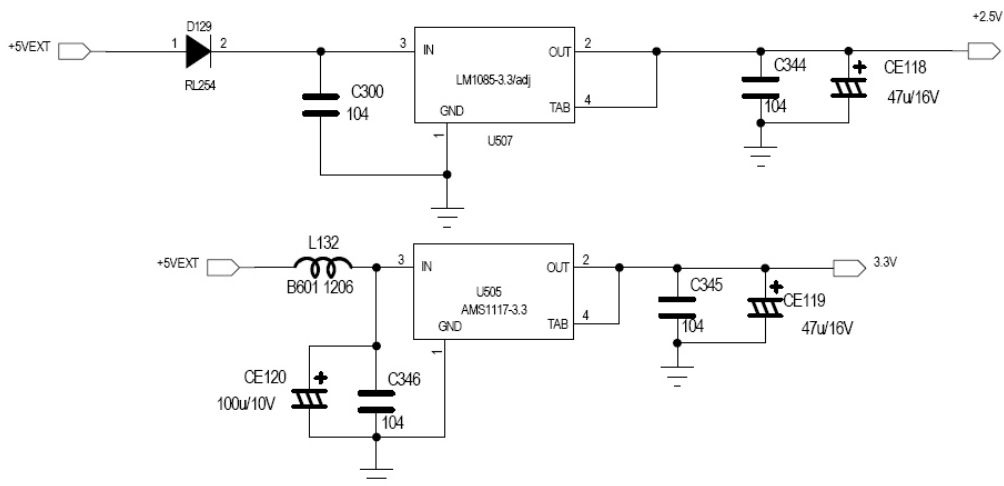

Figure 3.2.5.4 3.3V voltage stabilizing circuit

(2) Working principle: MST718 is a multi-function chip with built-in MCU and A/D converter, so the power supply adopts multi-group power supply. +5VEXT introduced above is supplied for the working of built-in MCU, so we do not introduce here. The picture mainly shows +2.5V and 3.3V power supply voltage stabilizing circuit and this power is mainly supplied for MST718 ADC circuit and LCD image processing circuit. U507 is 2.5V voltage stabilizing IC. To reduce IC power consumption, D129 is added for voltage drop. U505 is 3.3V voltage stabilizing IC.

## 5. DVD working power voltage stabilizing circuit

(1) DV33/1.8V voltage stabilizing circuit diagram is shown in the figure 3.2.5.5:

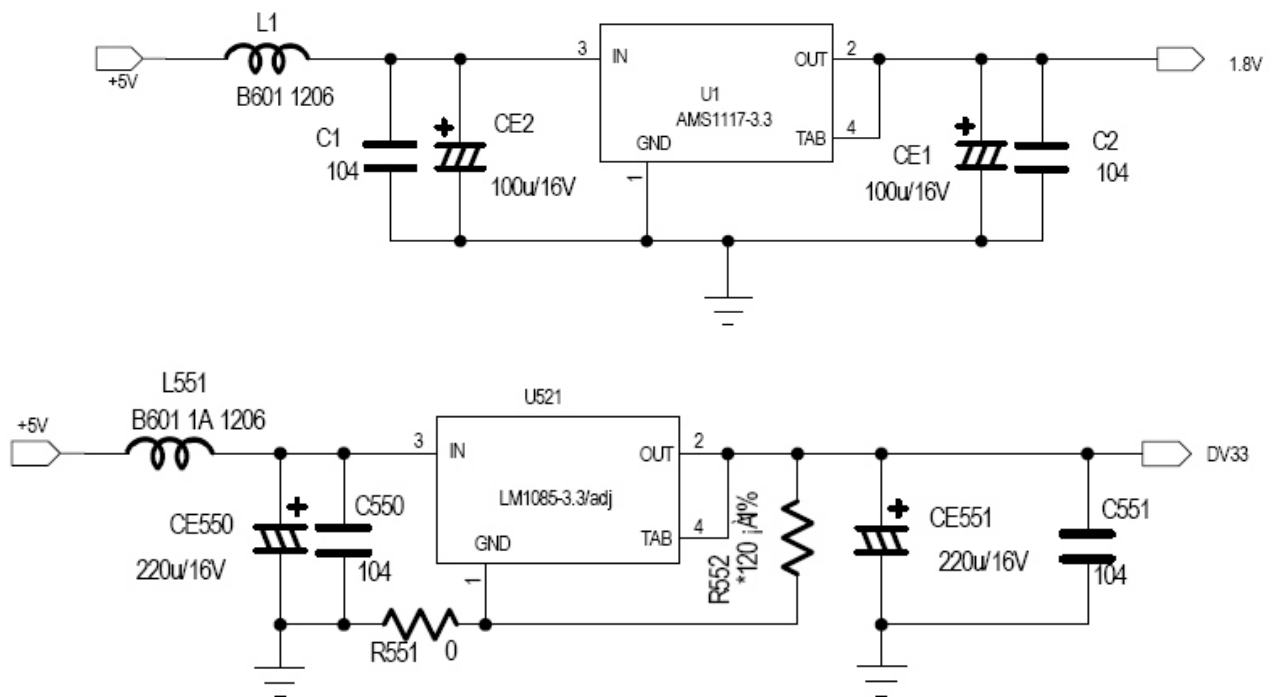

Figure 3.2.5.5 DV33/1.8V voltage stabilizing circuit

(2) Working principle: this circuit mainly supplies power for DVD part circuit. +5V power in the picture inputs to pin 3 of U1, through being voltage stabilized by U1, +1.8V voltage outputs from pin 2 of U1 to supply for decode chip Mt1389, at the same time +5V power inputs to pin 3 of U521, 3.3V power outputs from pin 2 of U521 to supply working power for DVD system circuit.

## 6. Inverter components control circuit

(1) Inverter components control circuit is shown in the figure 3.2.5.6:

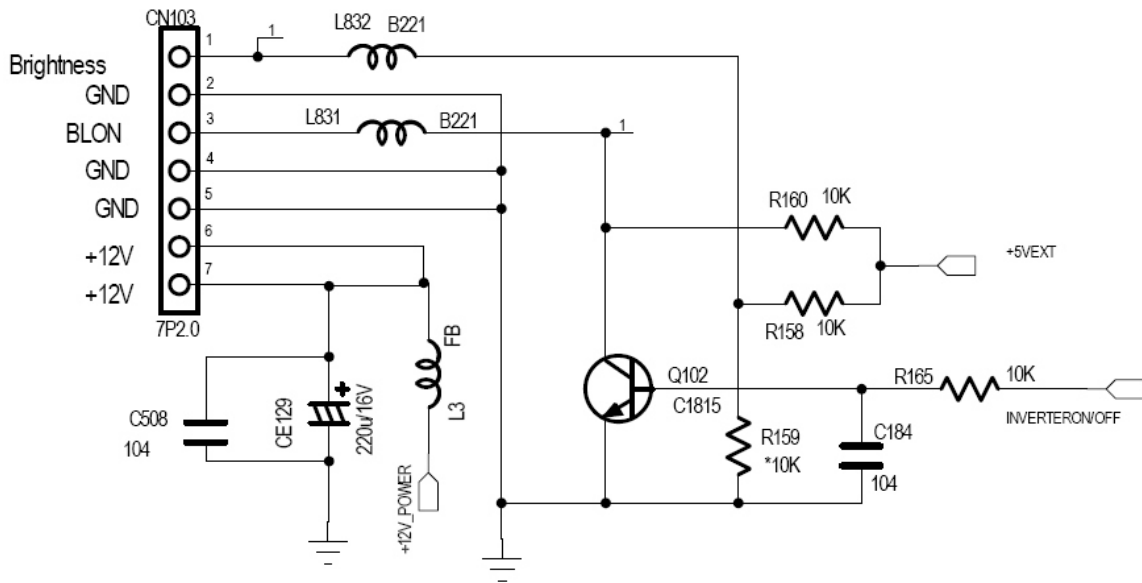

Figure 3.2.5.8 Inverter components control circuit

(2) Working principle: after machine power on, +12V power is normal, machine is in standby state, pin 76 of mst718 (INVERTERON/OFF) outputs high level, Q102 is saturated on, pin 3 of Cn103 is low level and boost board stops working. After machine enters power-on from standby, pin 76 of mst718 (INVERTERON/OFF) outputs low level, Q102 cuts off, pin 3 of Cn103 is high level, boost board enters working state. This signal does not send out until system starts up totally.



## Section Three Servicing Cases

### 3.3.1 Servicing cases

[ Example 1 ] symptom: machine not power on

Trouble description: after inserting power cord, standby indicator light is on. After pressing power switch, green indicator light flashes once and the machine power off.

Analysis and troubleshooting: according to trouble symptom, we judge that trouble mainly lies in power system. Firstly check whether power board can work normally. Test whether power board flat cable +12V is normal when power on; unplug the 6P power supply flat cable from power board to main board, after connecting with power, use multimeter to check whether 12V voltage output in power board flat cable holder is normal; insert the flat cable from main video board to power board and check whether voltage output is normal; press POWER button, after voltage skips to low level, machine power off, so we doubt that power board cannot load. To further conform the causes, unplug power cord, connect a - 10 ohm resistor in power board flat cable holder +12V position to ground (or change a power board for test), after connecting with power, voltage in this position changes all the time. According to the symptom, we can judge that power board cannot load. The reason is that 12V filtering capacitor has electric leakage/switch transformer has trouble, or the preliminary reverse clipping circuit cannot work normally, or Ic1377 protects ahead of time. After test, we find that the secondary rectifying and filtering circuit is normal, so we judge that trouble is caused by preliminary part. After power off, we check one by one and find that Vd2 in reverse clipping circuit has cut off. Change diode with the same specification, trouble is removed.

[ Example 2 ] symptom: power not on

Trouble description: after inserting power cord, indicator light is not on. Press POWER button and machine cannot power on.

Analysis and troubleshooting: according to trouble symptom, we judge that trouble lies in power circuit and system circuit. Firstly make sure whether power board has +12V voltage output; unplug 6P flat cable in Cn6 position, check voltage and 12V output is normal, which means that power board works normally. Press POWER button, check 12V voltage in Cn6 position and it is normal, which means there is no load or short-circuit on main board. Check 5V voltage of pin 2 of main board U503 and it is normal. Test after words and find that two ends of Ce503 have no 5V voltage output, so we doubt L503 has

Trouble. Use multimeter to test and find L503 has open circuit. When meets this symptom, do not hurry to power on, use multimeter to test whether resistance on two ends of Ce503 becomes small. After test, 5V power resistance to ground is normal (note: as for machine with abnormal resistance to ground, do not install L503 until trouble is removed). After changing L503, power on and test. Machine works normally and trouble is removed.

[ Example 3 ] symptom: machine not power on

Trouble description: after inserting power cord, red indicator light flickers all the time. Press POWER button and machine cannot power on.

Analysis and troubleshooting: according to trouble symptom, we judge that power part has short-circuit or large load. After power off, firstly check +12V resistance to ground of main board and resistance does not become small. Cut off the 6P power supply flat cable between power board and main board; connect a 10 ohm resistor between 12V power cord and ground wire on power board to act as load; use oscillograph to observe waveform on resistor, level changes all the time, and power board protection circuit begins to work. Low voltage part has two-channel over-voltage protection circuit, in which one performs constant output for 12V power through TI431 sampling; and the other makes the output less than 15.6V through 15V voltage stabilizing pipe. Check the peripheral elements of the two channels one by one and find that VD6/ 15V/0.5W has been stricken through. Change voltage stabilizing pipe with the same specification, trouble is removed.

[ Example 4 ] symptom: TV has no sound output

Trouble description: insert antenna, TV can receive program, but speaker has no sound output. External input audio is normal.

Analysis and troubleshooting: NICAM signals are received from tuner, which is used to receive TV signal and decompose the received signal to audio/video signal to output. When meets this kind of trouble, do not hurry to repair, firstly confirm whether there is sound output when in SCART, AV input mode. After confirming, there is sound output in other mode now, which means that U11 and speaker are good. Use oscillograph to test pin 14 of tuner MOINOIN and waveform is normal. This signal is coupled through Ce134 to pin 73 of chip U111 (STV8216), after processing inside chip, output from pin 28, 29 of U9 to U112 for amplifying output. Test pin 18, 19 and they are normal. Test pin 28, 19 and there is no waveform output. From this, we decide that the chip U111 may probably have trouble. Test power supply voltage of pin 20 and it is normal and crystal oscillation waveform output of chip is normal. Observe carefully and find that pin 28, 29 has the possibility of rosin joint. Use iron to add tin and weld again. After power on again, trouble is removed.

[ Example 5 ] symptom: tap machine slightly and picture has disturbance.

Trouble description: after power on, image display is normal and has white stripe flickering.

Analysis and troubleshooting: if there is disturbance after tapping machine, a certain or some elements in circuit may probably be not contacted properly. According to trouble symptom, trouble lies in the connecting board between display screen and main board. After checking machine flat cable, there is no abnormality; then take down connecting board, check carefully and find that there is a certain spring sheet in the socket on one end connecting with screen has sunk. Change connecting board flat cable holder and trouble is removed.

[ Example 6 ] Symptom: black screen when power-on

Description: from standby to power-on, screen is black all the time and panel indicator light can display normally.

Analysis and troubleshooting: according to servicing experience, if screen is black when power-on, firstly place the head of oscillograph near high voltage of boost board and find that oscillograph has no inductive waveform, so we can make sure that boost board has not outputted high voltage. Shown in the figure 3.3.1.1, use multi-meter to test +12V power supply voltage of CN4 and it is normal. Use multi-meter to test ON/OFF-INVERTER end and it is high level when in standby and low level in power-on in normal conditions, test Q102 B-E and it is connected, so we doubt that triode Q102 has trouble; use multi-meter diode level to test Q102 and triode Q102 has been stricken through. Change Q102 and trouble is removed.

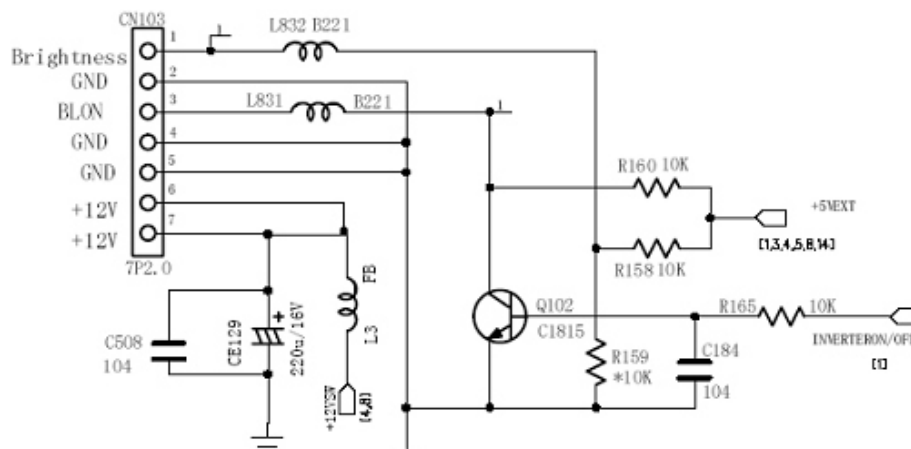

Figure 3.3.1.1 Inverter components control circuit

[ Example 7 ] Symptom: remote control has no function

Description: when pressing buttons on remote control, TV screen has no response.

Analysis and troubleshooting: test voltage of 5V-IR pin of Cn105 and it is +4.96, which is normal. When power is not on, test elements of L148, R342 between pin 1 of CN105 and chip U101 and they are all normal. Test pin 4 of remote control receiving board Cn801 to pin 1 of IR sensor and it is normally connected. After power on, test voltage of pin 1 of CN105 and it is +4.98V, which is also normal. Press

Buttons on remote control and find that pin 1 voltage of CN105 has no change. Under normal conditions, when pressing remote control, voltage changes from +4.98 to 3V plus several, which means remote control information has been received, so trouble should be in remote control receiver. After changing, trouble disappears.

[ Example 8 ] symptom: in AV input mode, video output end of SCART terminal has no vide signal output.

Trouble description: select signal source in AV state, switch on DVD Player to play demonstration disc and screen has no picture. SCART is used to output signal to external TV and there is still no picture display, but sound output is normal.

Analysis and troubleshooting: according to trouble symptom, we judge that trouble lies in video output circuit. If video signals of LCD of this player are normal, it means external input circuit is normal. After being processed by MST718, externally inputted video signals switch to digital video signals to output to display screen; other signals output from pin 34 as analog signals to SCART terminal through amplifying circuit to act as video output signals. shown in the figure 3.3.1.2, Use oscillograph to observe Ce108, there is no signal output, but the end that connects R42 and Q1 has signal output. Observe R2 carefully and the surface has leakage. After power off, use iron to heat R2 and then cut off. Change R2 with the same specification, trouble is removed.

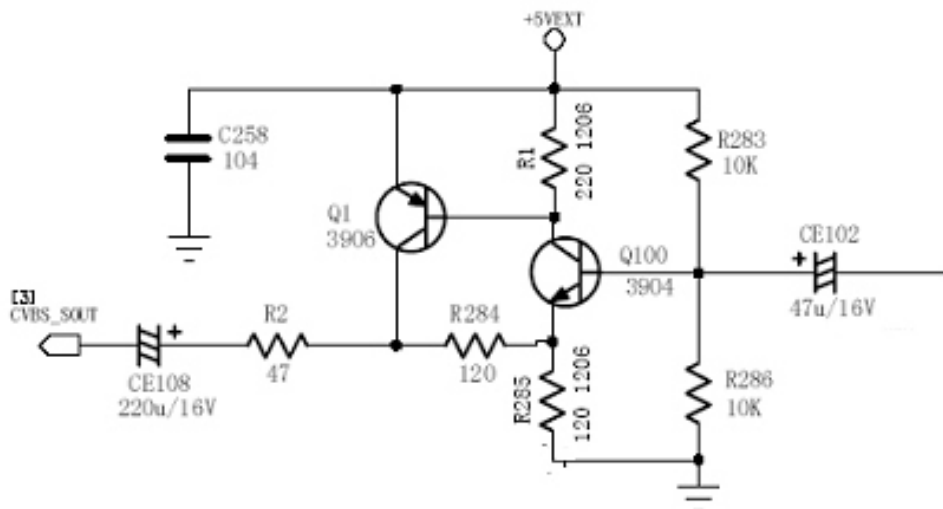

figure 3.3.1.2 video out circuit diagram

[ Example 9 ] Symptom: speaker has no sound

Description: in any external input mode, there is no sound output.

Analysis and troubleshooting: set signal source in "AV" state, turn on DVD Player demonstration disc and use oscillograph to test left/right speaker and find that there is no signal waveform output, so we confirm trouble should appear in precious stage circuit. test pin 8, 17 input pin of U112(TDA7226) and find that there is waveform input, but pin 9, 20 have no waveform output. Then test power supply Loop and +12V voltage changes to +10.8V after voltage drops, which is normal. Observe whether pin

Around has rosin joint or false welding. Weld again and trouble exists, so it may be TDA7266 internal processing circuit that has trouble. After changing U112, trouble disappears.

[ Example 10 ] Symptom: NICAM has no function

Description: press NICAN button on remote control and bilingual mode, stereo mode and mono mode cannot be changed each other.

Analysis and troubleshooting: after receiving "NICAM" signal from tuner, NICAM outputs from pin 11, through the filtering circuit composed by C301,C302, L301, enters pin 73 of STV8216, and then restores to audio signal through internal processing and then outputs to audio amplifying circuit from pin 28, 29, so firstly use oscillograph to test whether waveform of pin 11 (SIF) is normal. Then test pin 73 signal of U111 after filtering and find that waveform is normal and there is input but no output, so we can make sure U9 has trouble; test each power supply voltage and they are all normal. We confirm that trouble lies in U111 and peripheral elements. Test IC power supply and voltage is normal. Use oscillograph to test X301 and find that 27MHZ of X301 has no oscillation. After changing X301, crystal oscillator has oscillation and trouble is removed.

[ Example 11 ] symptom: TV cannot receive program

Trouble description: when TV is receiving program, there is no image output.

Analysis and troubleshooting: according to trouble symptom, we judge that trouble lies in tuner and peripheral elements. Channel search is adjusted after the communication between IIC bus and main chip MST718. Use oscillograph to observe pin 12 of tuner /CVBS and there is no waveform output, and there should be 0.7V modulating waveform output on normal cases. Check pin 3, 13 of tuner and +5V power supply and they are normal. Then check IIC bus waveform and it is normal. Check pin 11 and there should be sine wave with frequency 6MH and 1V output in normal cases but there is no actually, so we doubt tuner has trouble. Change tuner with the same specification, trouble is removed.

[ Example 12 ] symptom: only one side of headphone has sound output

Trouble description: in any signal source, left and right channels of speaker output are normal. After inserting headphone, left channel has no sound.

Analysis and troubleshooting: sound signals are amplified through TDA7266 after being outputted by STV8216 and then return to speaker through headphone loop. When headphone is not inserted, left and right channels of speaker are normal, so trouble lies in headphone loop obviously. Remove headphone board, firstly check whether flat cable holder has joint welding or rosin joint and it is normal after checking. Then check whether headphone holder contacts well and it is normal. Check resistor R702, C705 on left channel loop one by one and find R702 resistance is infinite. Use iron to heat two ends of R702 and surface has leakage after heating, and R702 has been damaged. Change elements with the same specification, trouble is removed.

[ Example 13 ] Symptom: noise appears when power on

Trouble description: press POWER button on remote control or control board to power on and off on each input mode and you may hear “pop” noise during the courses.

Analysis and troubleshooting: according to servicing experience, firstly check mute circuit when this kind of trouble appears. Shown in the figure 3.3.1.3, when power on, MUTE signal changes from low level to high level, and output high level through D120. When power off, ce151 outputs high level through D121 and the diode D21, R71 inputted to mute control circuit are added to base electrode of triode Q119 to make triode Q119 saturated on, now MUTE end is low level to realize power-on quieting effect. Now there exists noise when power on and off, so we judge that trouble lies in Q119 and its peripheral elements. After test, triode Q119 has been stricken through. Change the triode with the relevant model and trouble is removed.

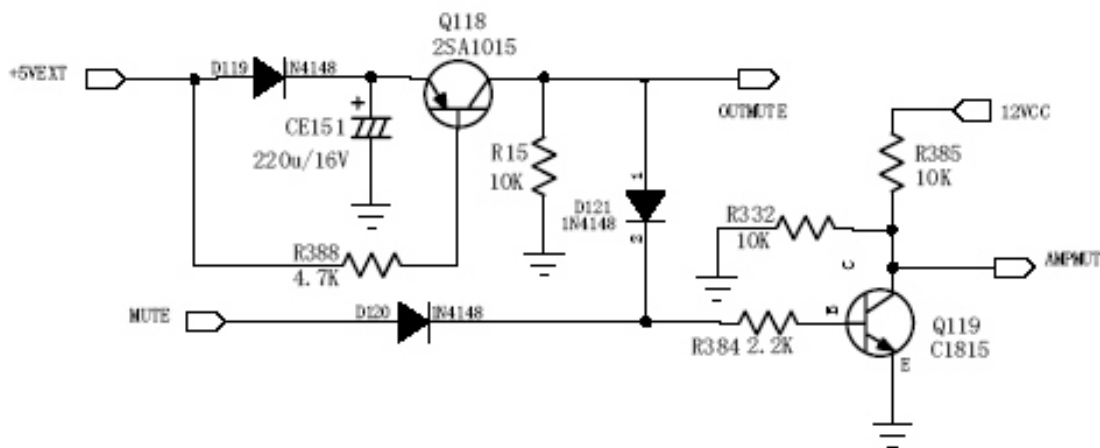

figure 3.3.1.3 mute circuit diagram

[ Example 14 ] symptom: do not read USB

Trouble description: disc read is normal when in DVD state; after inserting USB, USB data cannot be read out.

Analysis and troubleshooting: USB part is processed after being switched by electronic switch ADG713 and then inputting to Mt1389. Firstly check whether channel is normal, from USB board to main board through 22P flat cable cord and then to video main board, and this flat cable contact is bad. Firstly check whether USBM, USBP are normally connected and whether there is short-circuit to ground. After checking, USB board works normally. Then check lines on main board according to signal flow. USBP passes through L158, so we judge that Mt1389 main chip cannot work normally. Check power supply of each group and find that pin 49 USBVDD has no 3.3V voltage input. Check peripheral circuit and find L191 has disconnected. Change L191 with the same specification and trouble is removed.

[ Example 15 ] symptom: disc tray ejects out automatically

Trouble description: in DVD state, after loading disc, disc read is not available and disc tray ejects out automatically.

Analysis and troubleshooting: when the above trouble appears, firstly check whether loader flat cable has loosened. Check whether plug on loader flat cable has been oxidated and it is normal, so we doubt loader has trouble. Change loader and trouble is removed.

[ Example 16 ] symptom: left and right channels are not balanceable

Trouble description: sound of left speaker is lower than that of right channel

Analysis and troubleshooting: if channels are not balanceable, software setup may probably have trouble. Firstly reset TV part, trouble does not disappear, so we can judge that trouble lies in hardware. Disconnect power and check impedance of left/right speaker and it is normal. Test when machine begins to play DVD test disc normally. Connect pin 4, 12 of TDA7266, use oscillograph to observe the amplitude of left/right channel output of TDA7266 and left channel amplitude is smaller than that of right channel (note: now ground of oscillograph is connected with OUT- and detect head is connected with OUT+), so trouble lies in TDA7266. Change TDA7266 with the same specification and trouble is removed.

[ Example 17 ] symptom: do not read disc

Trouble description: in DVD state, CD/DVD disc cannot be read and then disc ejects out automatically.

Analysis and troubleshooting: check whether loader components flat cable contacts well and there is no abnormality; remove loader flat cable and check whether the contact position of plug and loader clasp has been oxidated. Change loader but trouble still exists, so trouble should lie in main board. Power on, switch in DVD state, observe disc reading condition of loader and main axis, focus, feed, trace action is normal, but disc type cannot detected. Observe focus carefully and find object lens twitters greatly, but cannot form slim light spot to shine on disc, so trouble may probably lie in focus circuit. Check pin 24, 25 of focus feedback loop Ba5954 and resistance value of R390 is normal. Use iron to heat C162, trouble disappears, so capacitor loses effect. Change capacitor with the same specification and trouble is removed.

[ Example 18 ] symptom: no DVD image

Trouble description: other working state of machine is normal, but DVD function cannot be used normally.

Analysis and troubleshooting: as for this kind of trouble, firstly judge whether trouble lies in DVD function circuit. Check Mt1389 power supply and it is normal, Mt1389 clock and reset signals are normal, so we doubt FLASH program loses. Power on, switch in DVD state and use oscillograph to observe whether FLASH pin has waveform. Remove FLASH, record program again and trouble is removed.

[ Example 19 ] symptom: colour distortion in DVD state

Trouble description: in DVD state, when playing CD/DVD disc, sound output is normal but colour is to

red with shadow.

Analysis and troubleshooting: if colour has distortion in DVD state, trouble may probably lie in SDRAM or Mt1389 or on CVBS output line. Switch from DVD state to SCART state firstly, picture colour is normal, so colour has distortion before MST718 input. CVBS outputs from Mt1389 and then enter MST718 through frequency selection network for image processing, so trouble should lie in frequency selection network. Power off, use multimeter to check whether each resistor and capacitor element has resistance sudden change, and R395/75U has sudden change with only 15-ohm, which is caused by the large attenuation of the signals outputted from DVD. Change resistor with the same specification and trouble is removed.

[ Example 20 ] symptom: do not read DVD disc

Trouble description: in DVD state CD playing is normal, DVD playing is not available and then DVD disc ejects out automatically.

Analysis and troubleshooting: firstly check whether DVD protection point of loader has joint welding phenomenon and there is no abnormality. Change loader and trouble still exists, shown in the figure 3.3.1.4, so trouble lies in CD/DVD mode switch circuit. CD/DVD mode switch is controlled by pin 112 I/O port level of Mt1389 and VRCD and VRDVD switch is realized through selecting drive circuit. When disc switches in CD and DVD, the switch of IOA in high and low level means that Mt1389 control port outputs normally. When IOA is low level, TRDVD should be low level and it is high level actually. Check R187 and circuit has disconnected because of rosin joint. Use iron to weld again and confirm and trouble is removed.

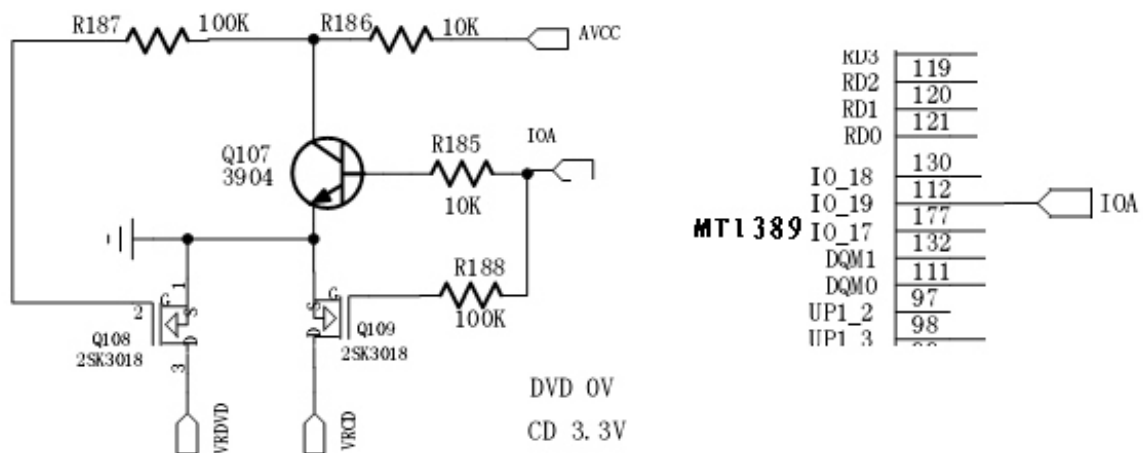

figure 3.3.1.4 CD/DVD mode switch circuit diagram



### 3.3.2 Troubleshooting flow chart

[ Flow chart 1 ] Trouble symptom: standby light is not on

Trouble description: connect with power, standby indicator light is not on, machine has no response and buttons have no function.

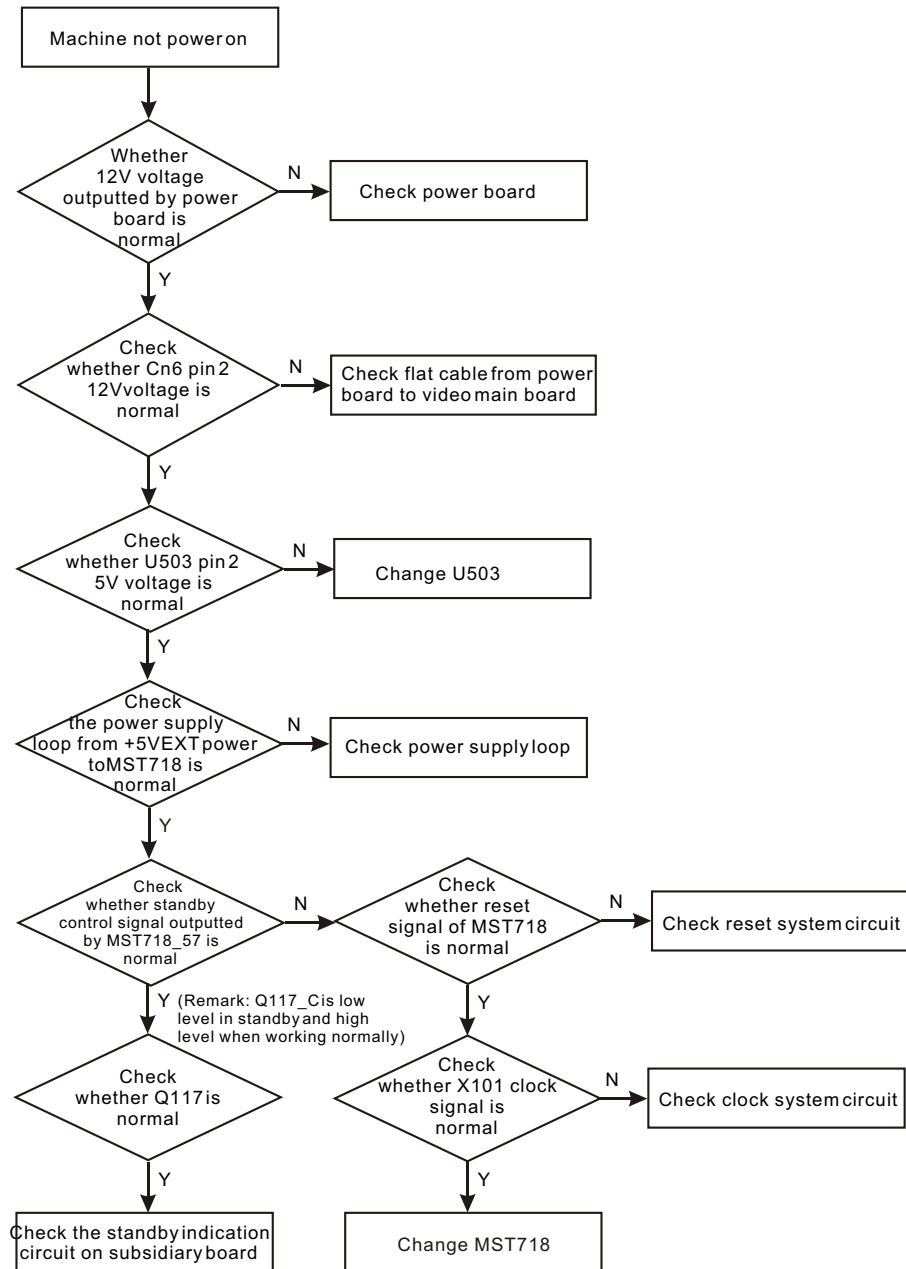

[ Flow chart 2 ] Symptom: power not on

Trouble description: test after machine power on, standby indicator light is not on and +12V power outputted by power board is abnormal.

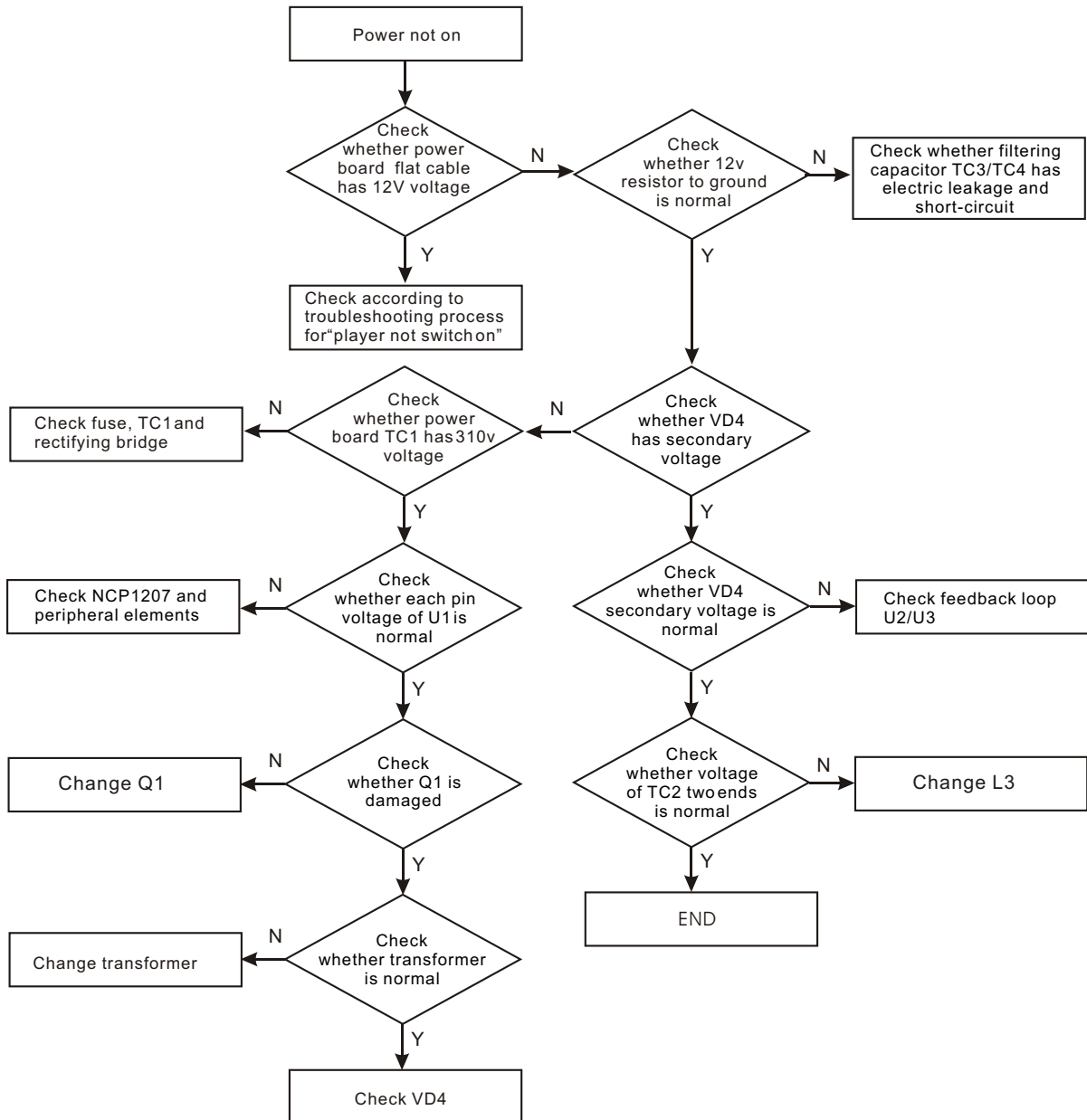

[ Flow chart 3 ] Symptom: no sound

Description: there is image, but no audio output

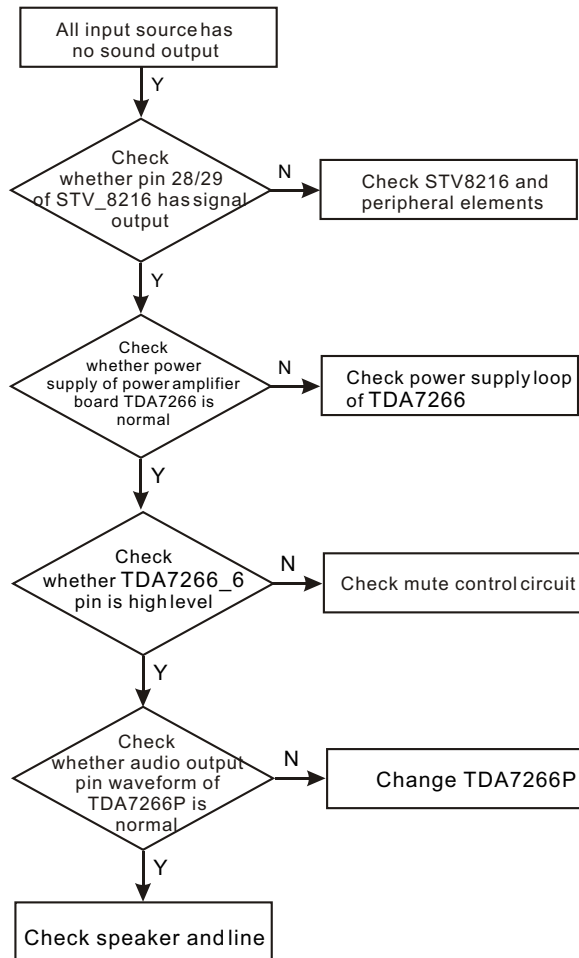

[ Flow chart 4 ] Symptom: white screen

Description: screen is white and indicator on

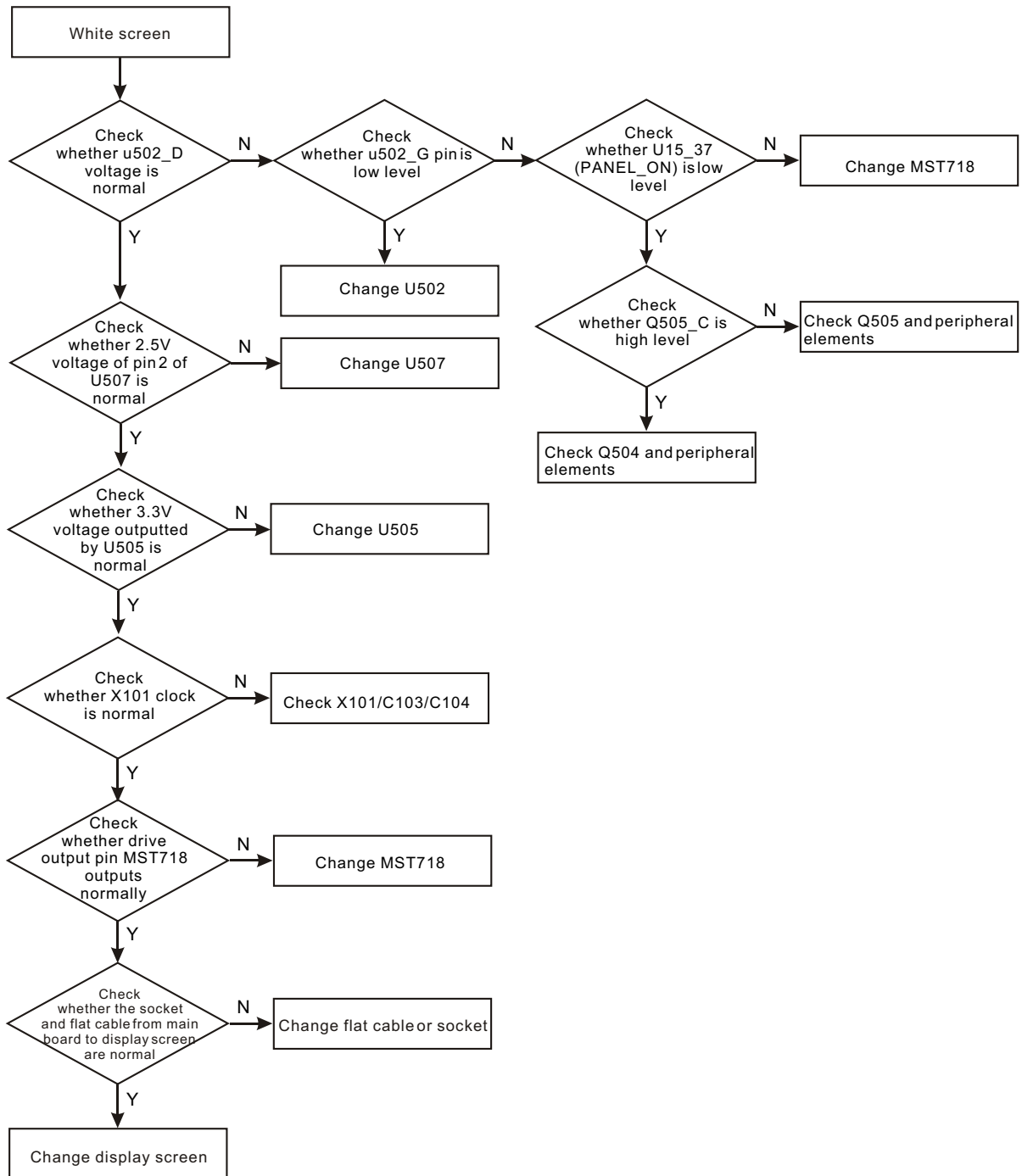

[ Flow chart 5 ] Symptom: DVD has no sound

Trouble description: when machine is set in DVD state, there is image but no sound. External input and TV sound are normal.

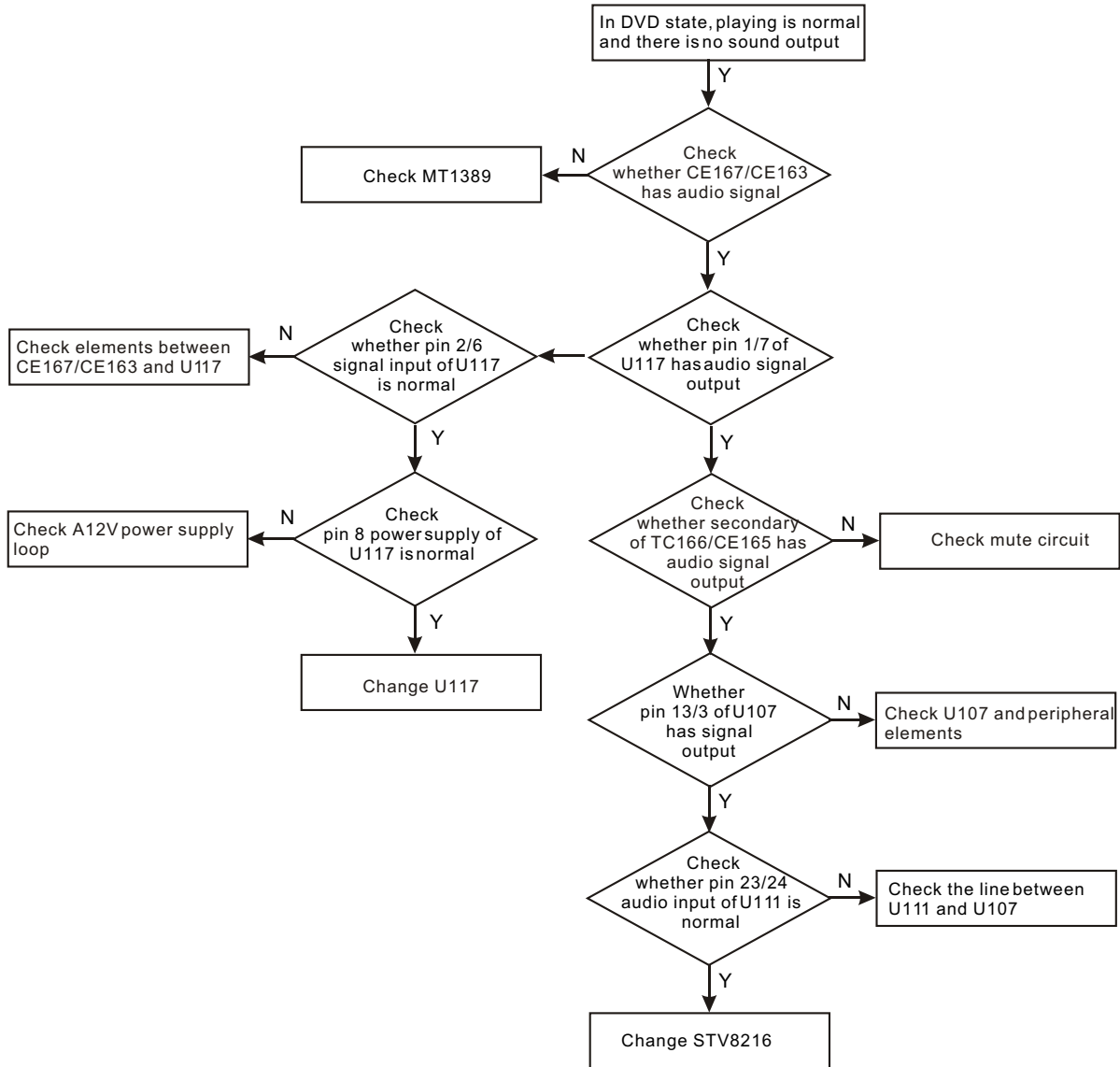

[ Flow chart 6 ] Symptom: black screen

Trouble description: after power on, screen has no display and backlight cannot be on

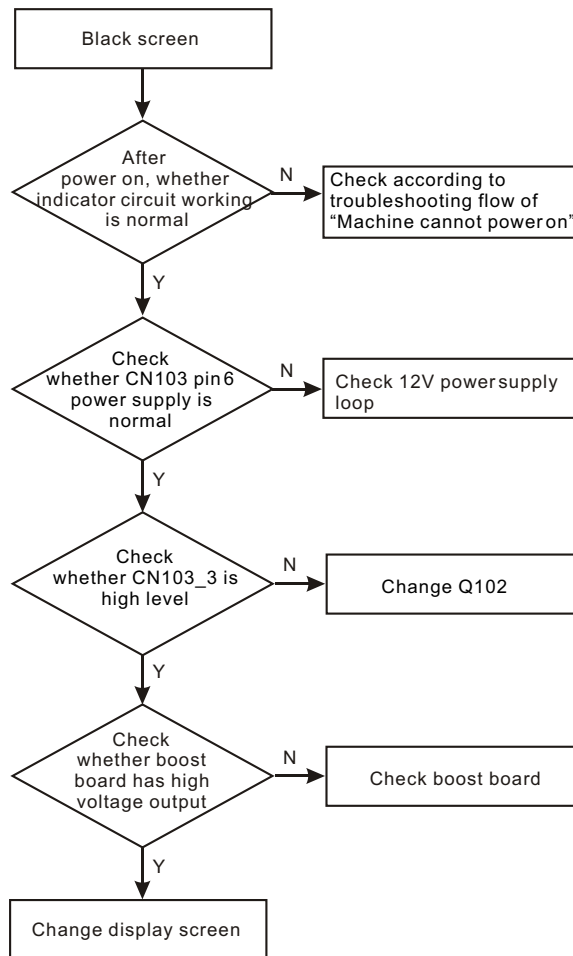

[ Flow chart 7 ] Symptom: DVD has no image

Description: DVD has no image but has sound.

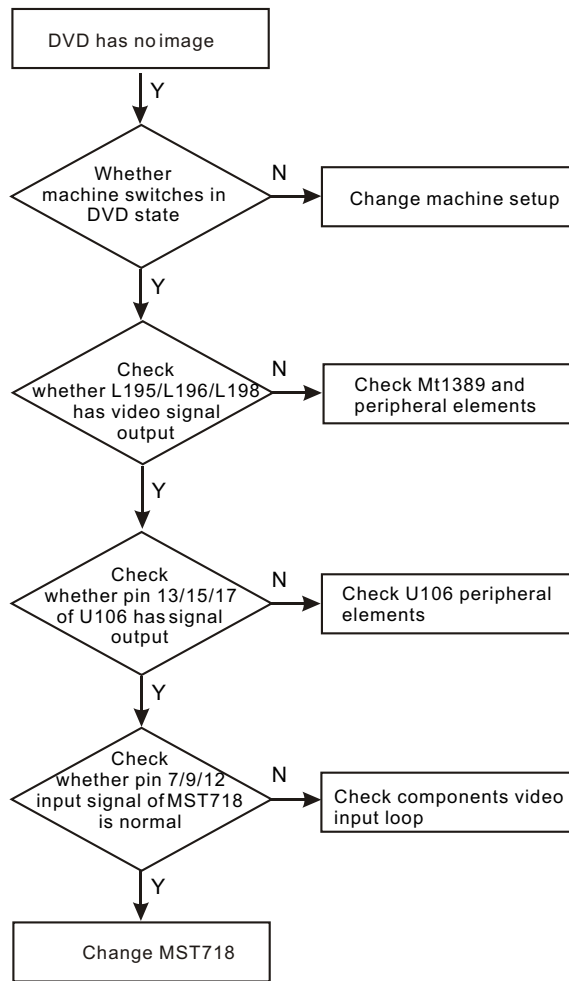

[ Flow chart 8 ] Symptom: TV cannot search channels

Description: channel cannot be searched

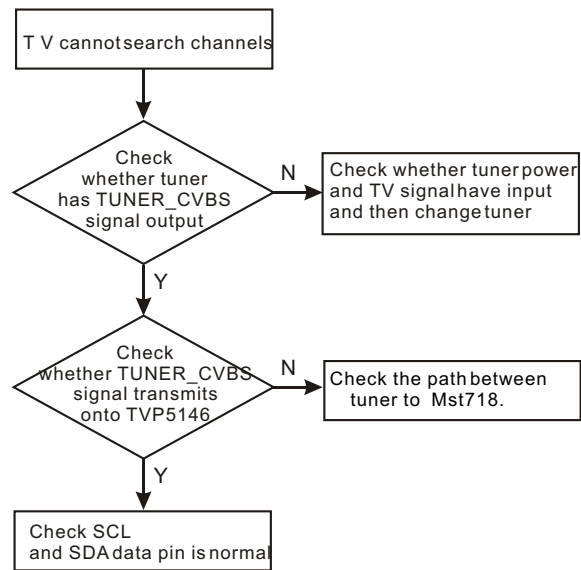



[ Flow chart 9 ] Symptom: player not power on

Description: switch on power, indicator light is not on and buttons have no function.

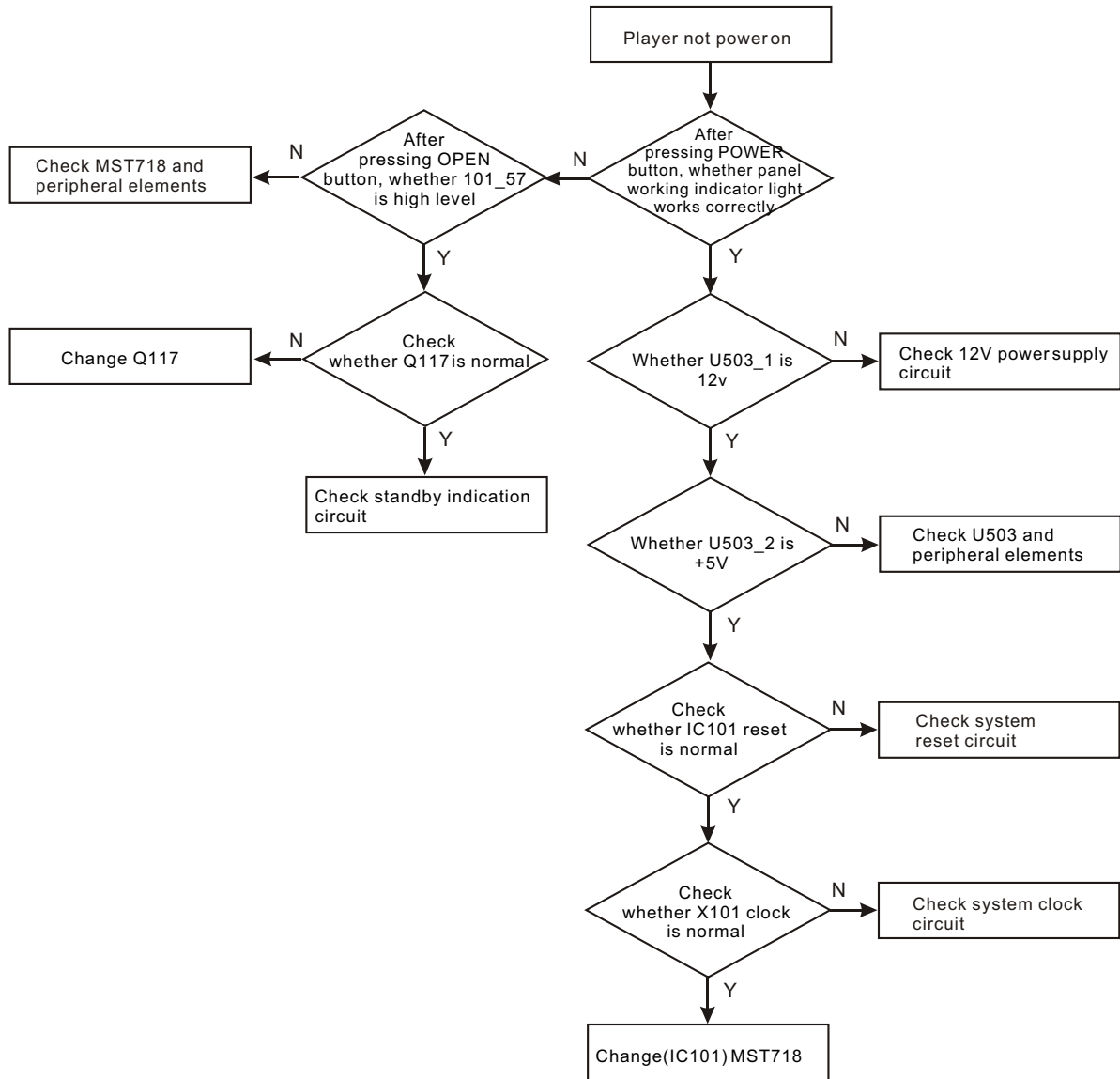

[ Flow chart 10 ] symptom: NICAM has no function

Description: NICAM has no function and cannot be realized

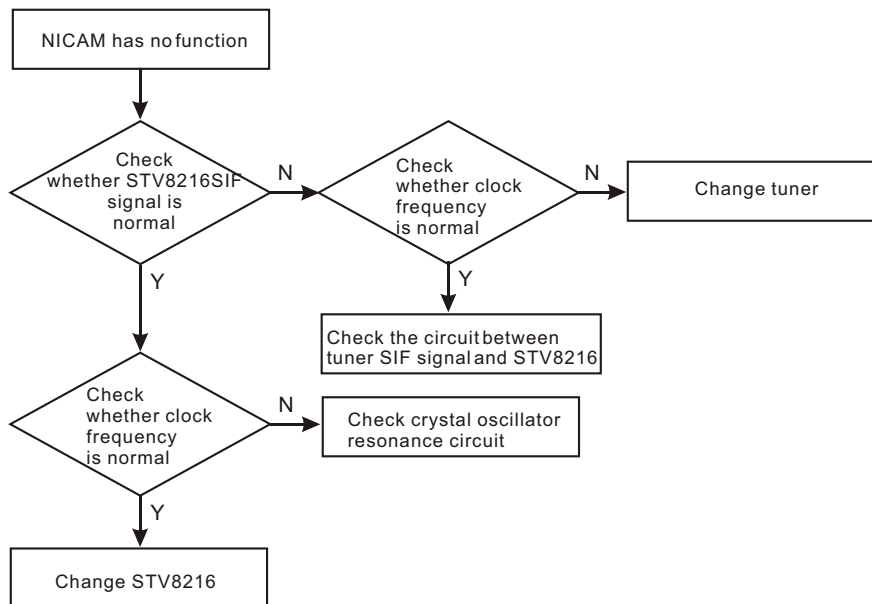

[ Flow chart 11 ] Symptom: screen image flickers

Description: screen image flickers and sound is normal

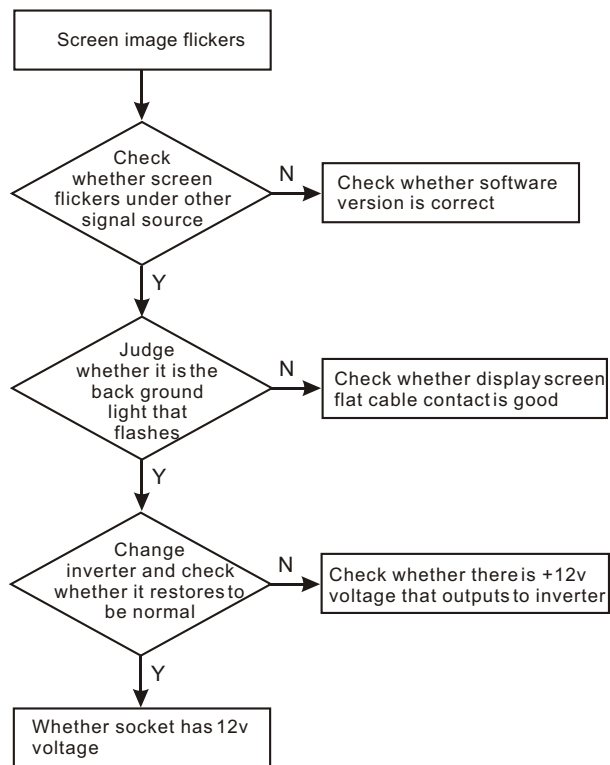

[ Flow chart 12 ] Symptom: colour has distortion

Description: picture colour has distortion



## Section Four Waveform diagram

This section collects signal waveform diagram of audio, video and each unit circuit with the purpose to help servicing personnel to judge where trouble lies in accurately and quickly to improve servicing skills. For the difference of oscillograph's type, model and tuner, a certain difference may exist, so the servicing personnel are expected to pay more attention to check in daily operation.

1. System reset signal waveform diagram: waveform comparison diagram for +5EXT and system reset pin during the course of power on.

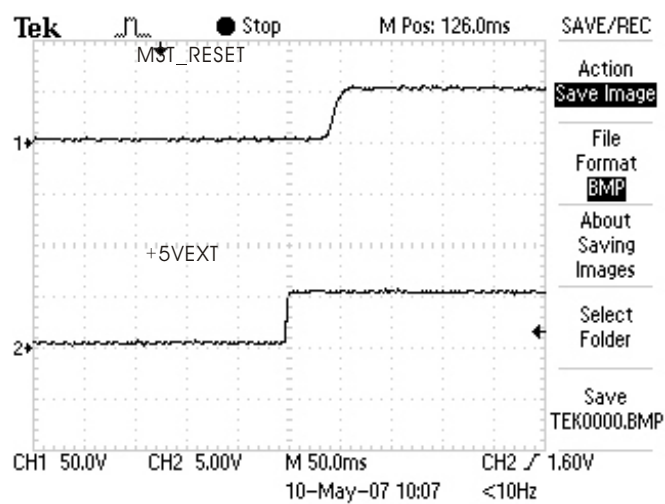

2. U104\_2(SO) waveform diagram:

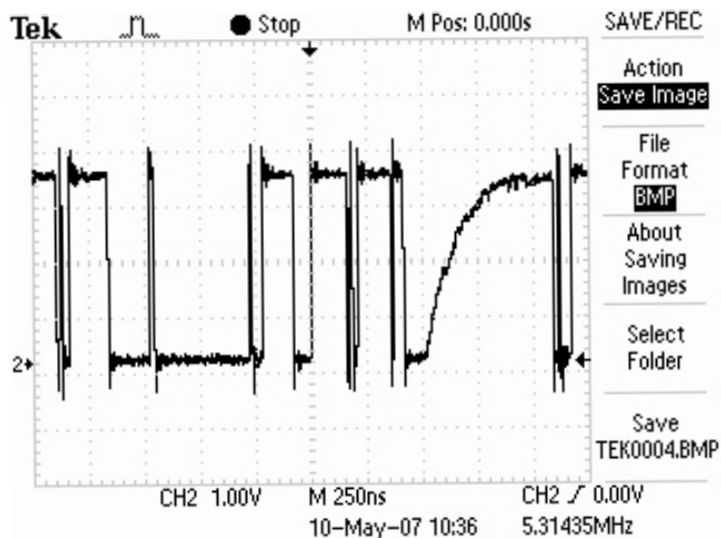

3. U104\_1 (CE) gating signal waveform diagram

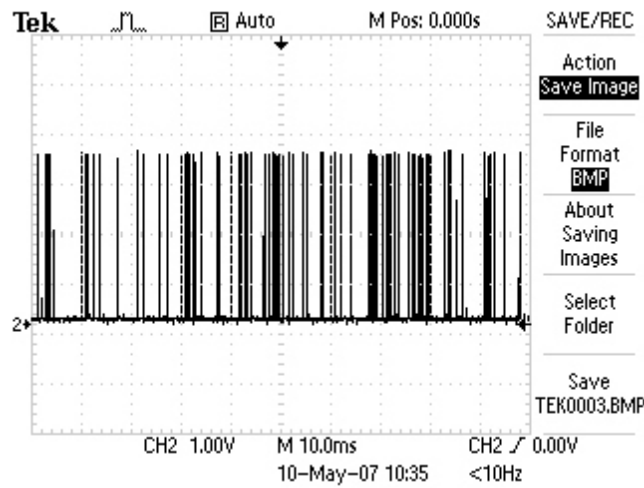

4. U104\_6 (SCK) clock signal input waveform diagram

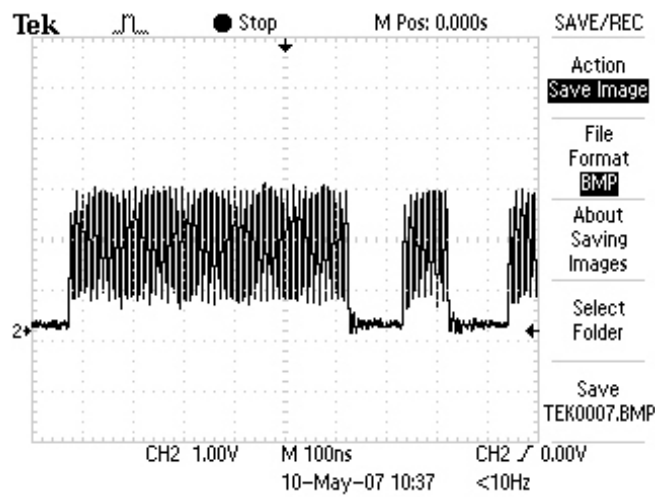

5. U104\_5 (SI) data input pin waveform diagram

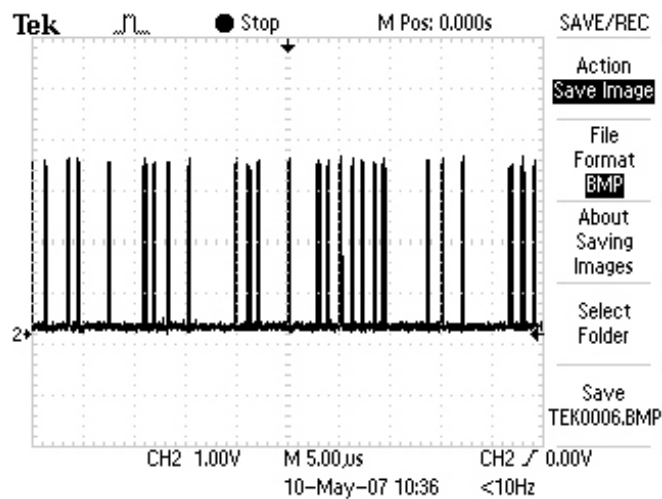

6. MST718 clock signal waveform diagram: waveform diagram when X101 is working (frequency 12MHZ)

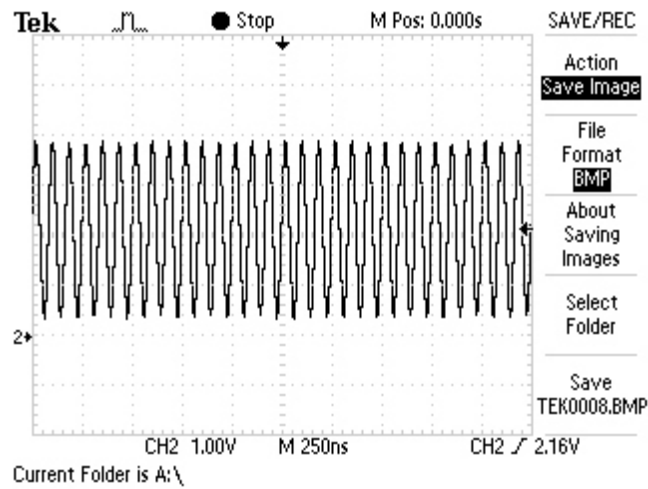

7. Q1\_C:video signal waveform diagram for pin when machine is receiving Q1\_C standard signal source in TV mode.

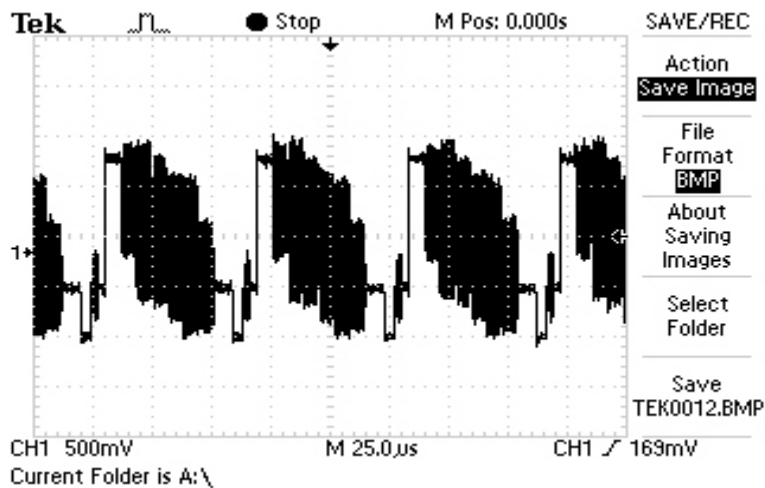

8. U103\_6: waveform diagram of SCL in IIC bus

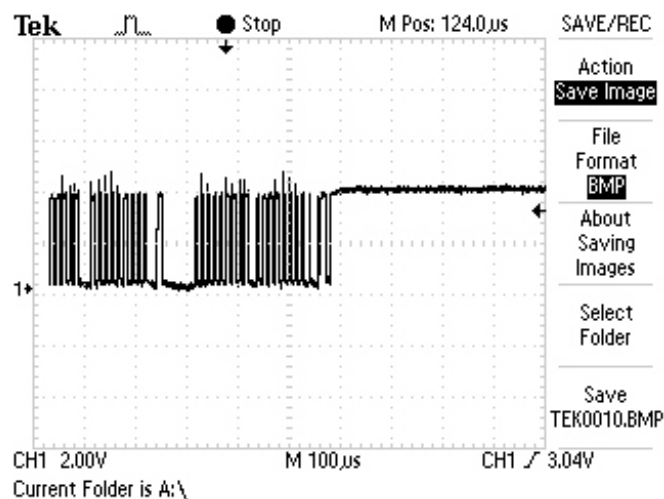

9. U103\_5: waveform diagram of SDA in IIC bus

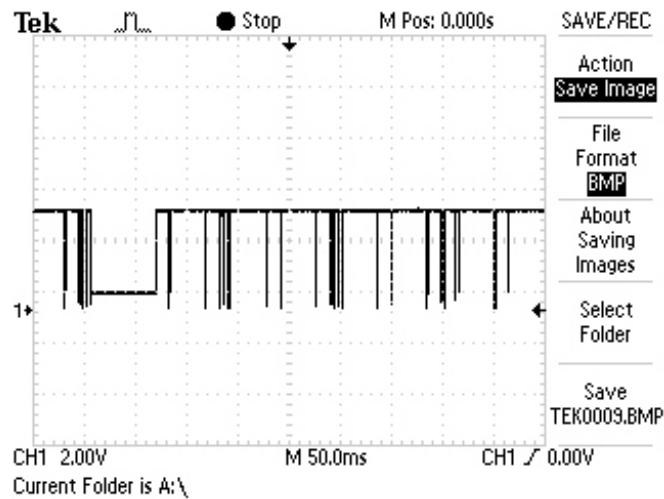

10. TV audio signal waveform diagram: waveform diagram for audio signals outputted by U114\_14 pin when machine is receiving standard signal source in TV mode.

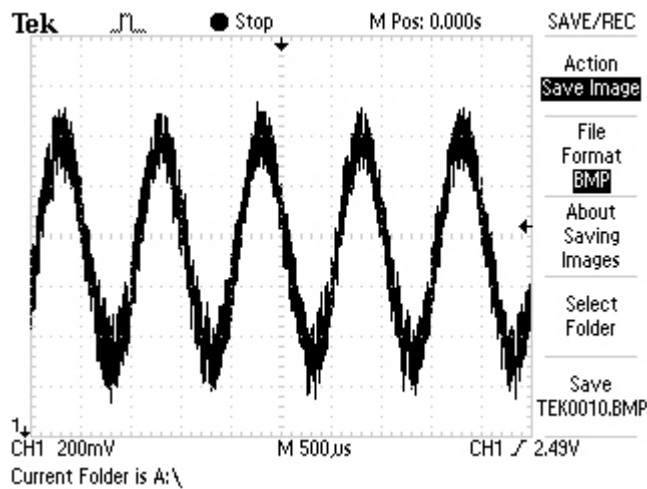

11. TV video signal waveform diagram: waveform diagram for video signals outputted by U114\_12 pin when machine is receiving standard signal source in TV mode.

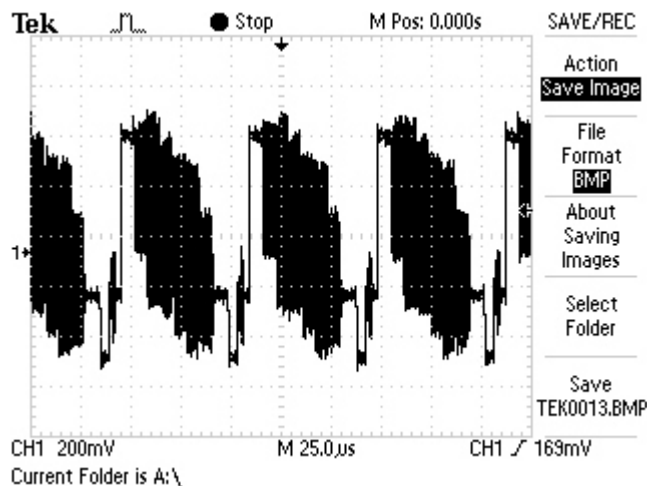



12. U001\_12: waveform diagram for video signals outputted by pin 12 of tuner when machine is receiving TV signal in TV mode.

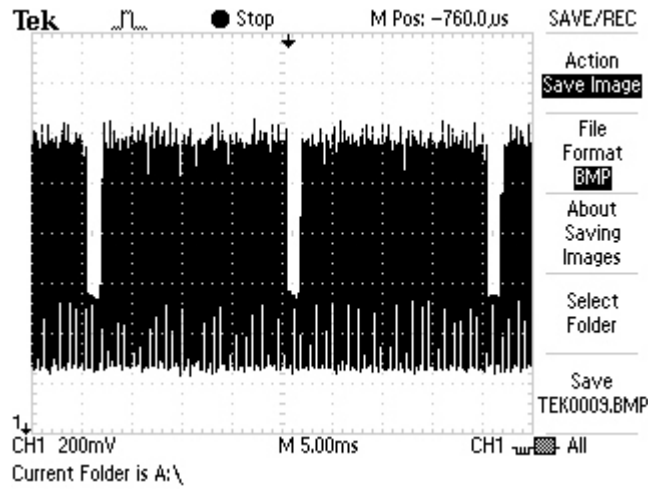

13. U001\_11: output waveform diagram of NICAM output pin

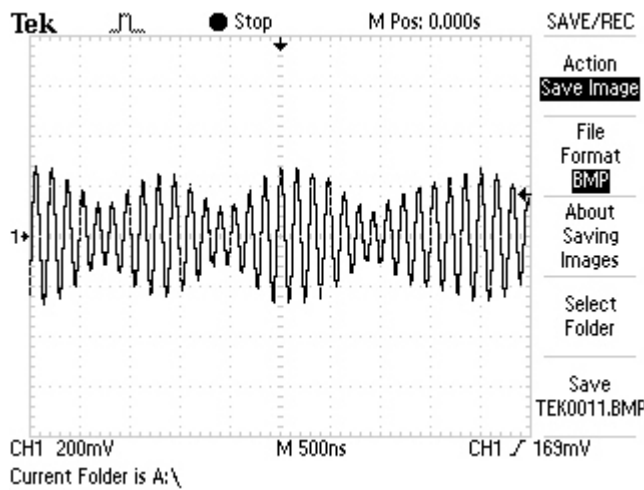

14. NICAM processing circuit clock signal waveform diagram: waveform diagram when :X301 is working (frequency 27MHZ).

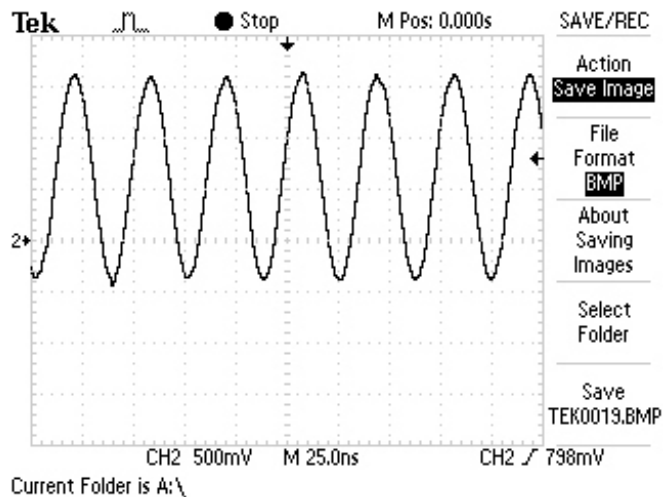

15. CN1\_11 display screen drive clock signal waveform diagram

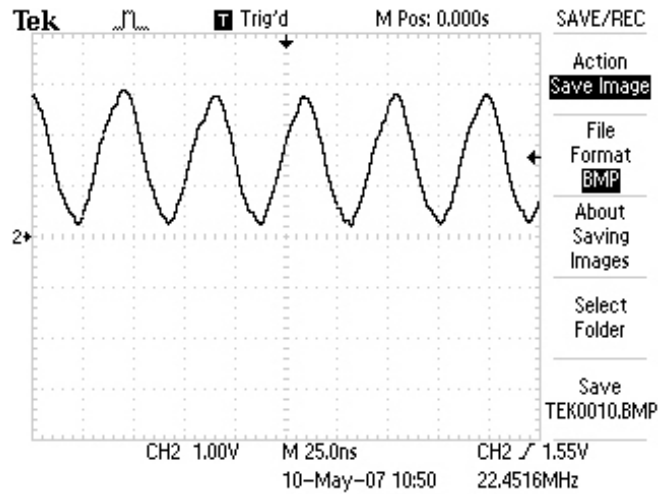

16. CN1\_12 display screen enable control end waveform diagram

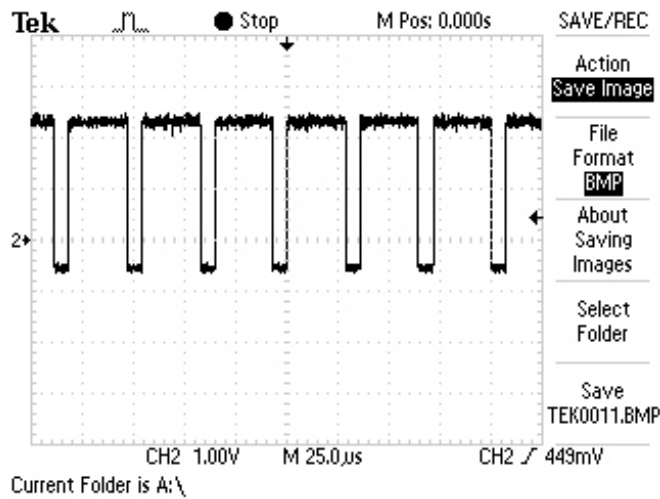

17. CN1\_12 waveform diagram of VSYNC signal outputted by MST718

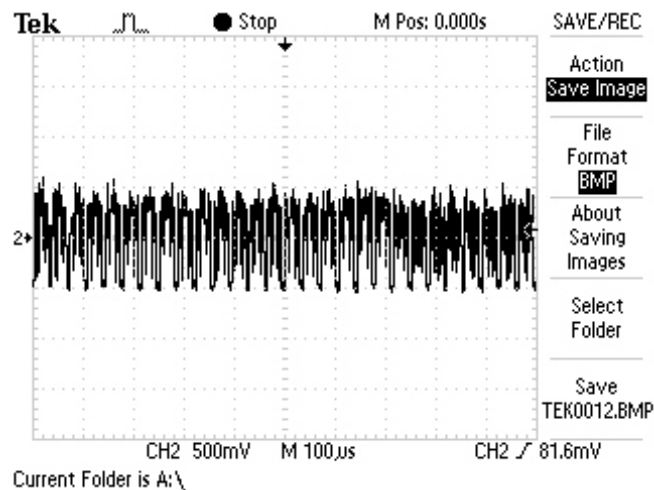

18. CN1\_16 HSYNC signal waveform diagram.

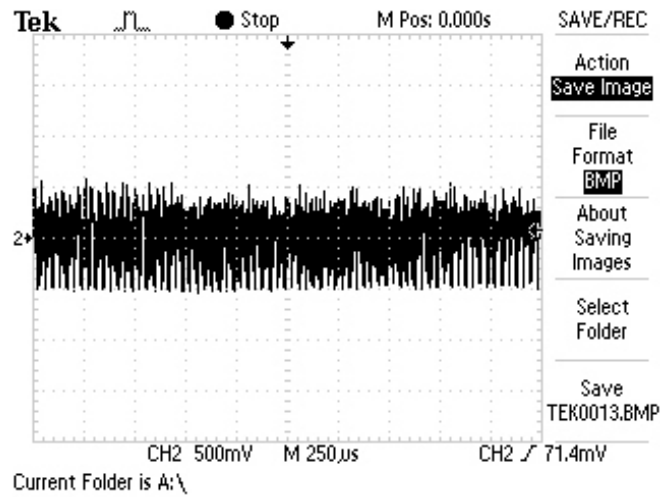

19. waveform diagram of DR signal outputted by TTL (test point is CN1\_19 and test machine when setting in DVD state)



20. waveform diagram of DG signal outputted by TTL (test point is CN1\_29 and test machine when setting in DVD state)

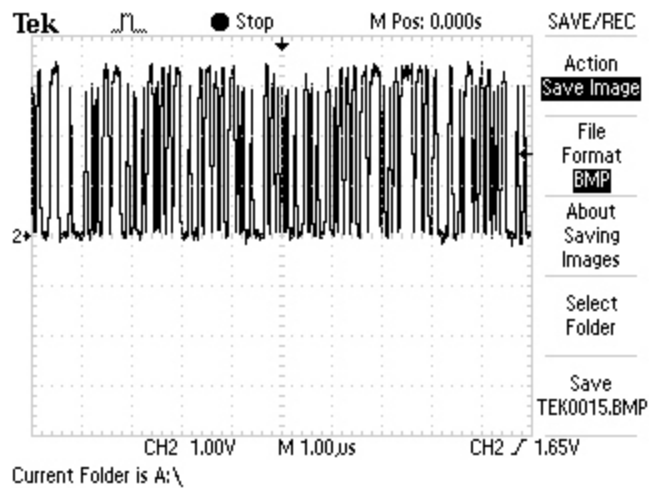

21. waveform diagram of DB signal outputted by TTL (test point is CN1\_39 and test machine when setting in DVD power-on picture state)

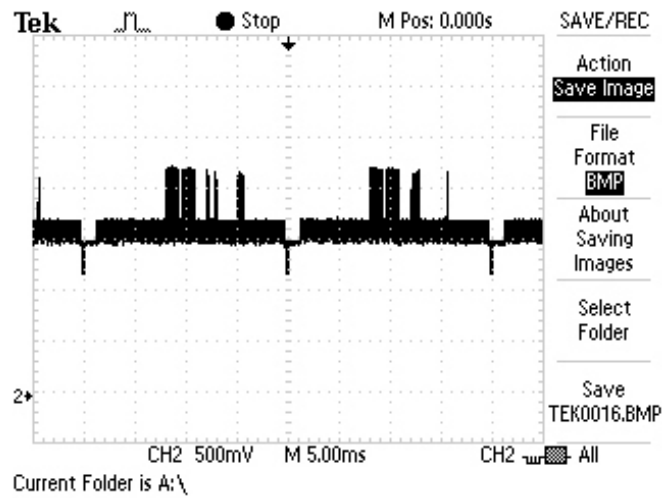

22. 8216\_28: waveform diagram after the audio signals from tuner are processed by STV8216 and then output from pin 28/29 when machine is receiving standard signal source in TV mode.

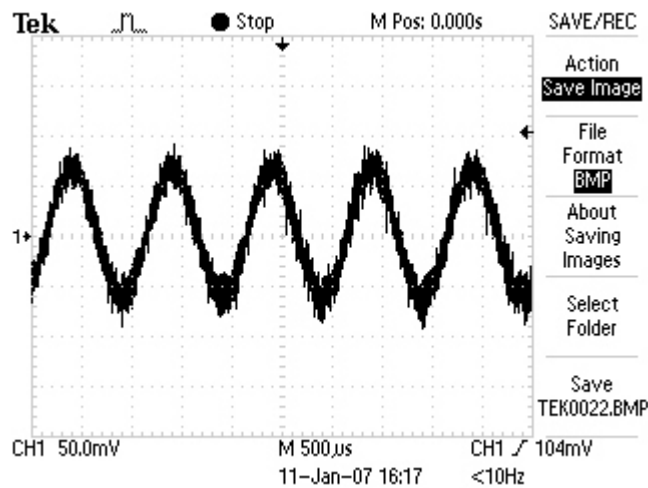

23. 8216\_1: waveform diagram after audio signals from tuner are processed by STV8216 and output from pin 1/2 when machine is receiving standard signal source in TV mode.

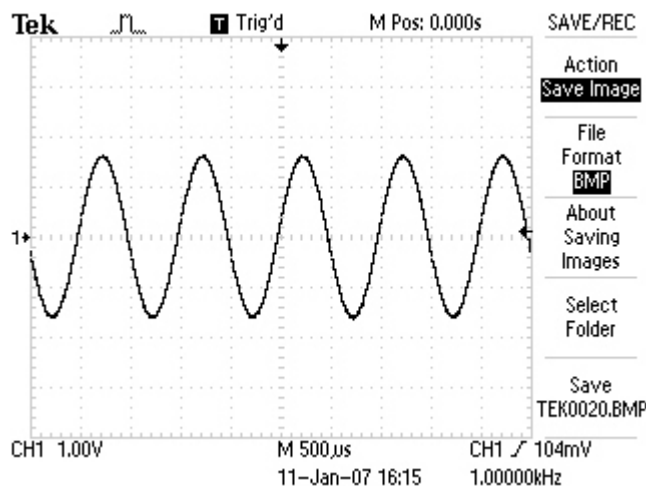

24. 8216\_18: when machine is in DVD state, audio signals outputted by Mt1389 output from pin 18/19 after being processed by CD4052/STV8216.

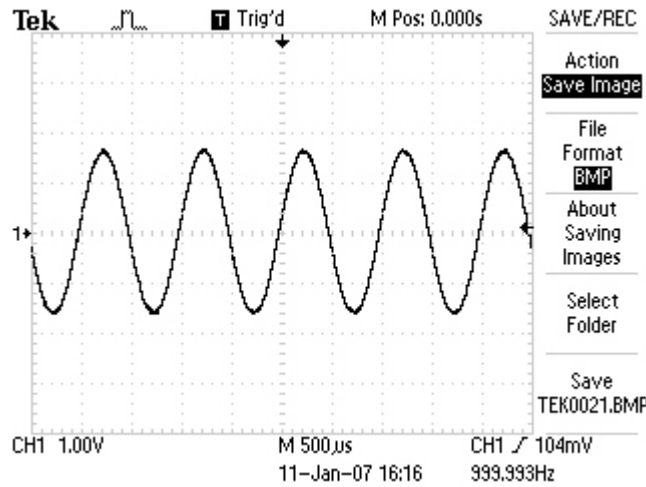

25. PANEL\_ON: waveform comparison diagram for STBY and PANEL\_ON signal when machine enters from standby to power-on.

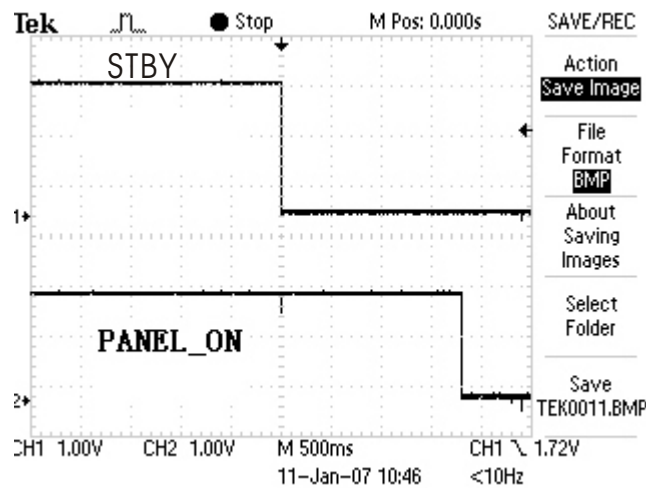

26. INVERTER: waveform comparison diagram for STBY and ON/OFF\_INVERTER signal when machine enters from standby to power-on.

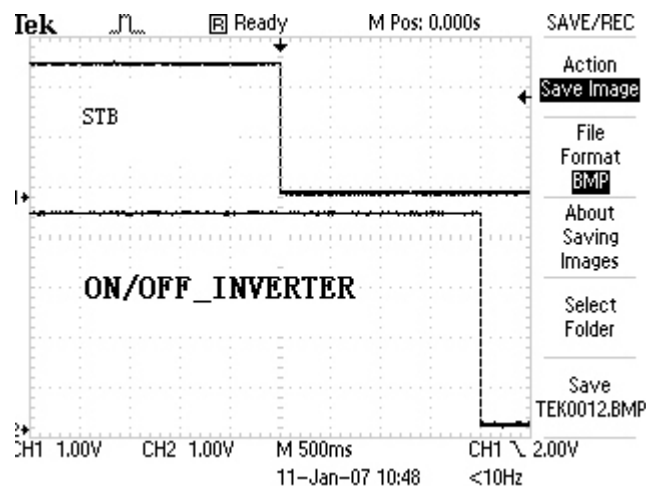

## Section Five Function Introduction to IC

### 3.5.1 function introduction to SDRAM(HY57V641620HGT-7 )U301

The function of SDRAM (U301) in the player is to save program taken out by Mt1389 from FLASH and information of picture and sound taken out from disc when the player is working to form damping, add the stability of information output and add anti-vibration of the player. The pin function and real voltage are shown as the following table:

Pin	Name	Function	Data direction	Voltage when no disc	Pin	Name	Function	Data direction	Voltage when no disc
1	VDD	3.3V power supply		3.18	28	VSS	Ground		0.01
2	DQ0	Data bus	I/O	0.94	29	MA4	Address bus	I	1.65
3	VDDQ	3.3V power supply	I/O	3.19	30	MA5	Address bus	I	1.74
4	DQ1	Data bus	I/O	0.9	31	MA6	Address bus	I	1.49
5	DQ2	Data bus	I/O	1.3	32	MA7	Address bus	I	1.22
6	VSSQ	Ground		0	33	MA8	Address bus	I	0.05
7	DQ3	Data bus	I/O	1.2	34	MA9	Address bus	I	0.04
8	DQ4	Data bus	I/O	1.5	35	MA11	Address bus	I	0.04
9	VDDQ	3.3V power supply		3.18	36	NC	Blank pin		0.01
10	DQ5	Data bus	I/O	0.7	37	CKE	Clock enable signal	I	1.22
11	DQ6	Data bus	I/O	0.45	38	CLK	System clock input	I	1.68
12	VSSQ	Ground		0	39	UDQM	Data in/out screen-shielded signal	I	2.42
13	DQ7	Data bus	I/O	0.8	40	NC	Blank pin		0.01
14	VDD	3.3V power supply		3.14	41	VSS	Ground		0.01
15	LDQM	Data in/out screen-shielded signal	I	2.46	42	DQ8	Data bus	I/O	0.6
16	WE	Write control signal	I	3.17	43	VDDQ	3.3V power supply		3.19
17	CAS	Line address gating signal	I	3.01	44	DQ9	Data bus	I/O	0.91
18	RAS	Row address gating signal	I	3.13	45	DQ10	Data bus	I/O	0.8
19	CS	Chip selection signal	I	2.95	46	VSSQ	Ground		0.01
20	SD-BS0	Section address 0 gating signal	I	1.8	47	DQ11	Data bus	I/O	0.79

21	SD-BS1	Section address 1 gating signal	I	2	48	DQ12	Data bus	I/O	1.16
22	MA10	Address bus	I	0.04	49	VDDQ	3.3V power supply		3.19
23	MA0	Address bus	I	0.36	50	DQ13	Data bus	I/O	1.15
24	MA1	Address bus	I	0.35	51	DQ14	Data bus	I/O	1.24
25	MA2	Address bus	I	2.38	52	VSSQ	Ground		0.01
26	MA3	Address bus	I	1.59	53	DQ15	Data bus	I/O	0.68
27	VDD	3.3V power supply		3.19	54	VSS	Ground		0.01

## 3.5.2 Function introduction to STV8216(u111)

### 1. Description

TV Sound Demodulator: provides all the necessary circuitry for the demodulation of audio transmissions of European and Asian terrestrial TV broadcasts. The various transmission standards are automatically detected and demodulated without user intervention.

Audio Processor: based on DSP technology, independently controls loudspeaker, subwoofer and headphone signals. It offers basic and advanced features, such as a ST Wide Surround, Equalizer, Automatic Loudness and Smart Volume Control for television viewer comfort. The STV8226/36 versions can perform additionally the SRS 3D Surround for stereo and mono signals.

Audio Matrix: 3 stereo and 1 mono external analog audio inputs to loudspeakers and headphone, with 2 stereo external analog audio outputs (SCART compatible).

### 2. Feature

- # NICAM, AM, FM Mono and FM 2 Carrier Stereo Demodulators for all sound carriers between 4.5 and 7 MHz
- # Spatial Sound Effects (ST Wide Surround and Pseudo-Stereo)
- # Mono input provided for optimum AM Demodulation performances
- # Subwoofer output with Volume Control and Programmable Bandwidth
- # Demodulation controlled by Automatic Standard Recognition System
- # Loudspeaker and Headphone outputs with Volume/Balance Controls and Beeper
- # Sound IF AGC with wide range
- # Overmodulation and Carrier Offset recovery
- # Smart Volume Control
- # 5-band Equalizer & Bass/Treble Control
- # SRS® 3D Surround
- # 3-to-2 Analog Stereo Audio I/Os (SCART compatible) with Audio Matrix
- # Low-noise Audio Mutes and Switches

# I<sup>2</sup>S Output to interface with Dolby® ProLogic® Decoder

# Automatic Loudness Control

# I<sup>2</sup>C Bus-controlled

# Single and standard 27 MHz Crystal Oscillator

# Embedded 3.3 V Regulators

# Power supplies: 3.3 V Digital, 5 V or 8 V Analog

# I = Input

# O = Output

# OD = Open Drain

# B = Bidirectional

# A = Analog

# AP = Analog Power Supply

# DP = Digital Power Supply

### 3. Pin Definitions

PIN	Name	Type	Function
1	AO1L	A	Left SCART1 Audio Output
2	AO1R	A	Right SCART1 Audio Output
3	NC		Not Used
4	NC		Not Used
5	NC		Not Used
6	NC		Not Used
7	VDDC	AP	3.3 V Power Supply for Audio DAC/ADC
8	GNDC	AP	0 V Power Supply for DAC/ADC
9	AI1L	A	Left SCART1 Audio Input
10	AI1R	A	Right SCART1 Audio Input
11	VMC1	A	Switched VREF Decoupling Pin for Audio Converters (VMCP)
13	VMC2	A	VREF Decoupling Pin for Audio Converters (VMC)
14	AI2L	A	Left SCART2 Audio Input
15	AI2R	A	Right SCART2 Audio Input
16	VDDA	AP	3.3 V Power Supply for Audio Buffers, Matrix & Bias
17	GNDAH	AP	0 V Power Supply for Audio Buffers & SCART
18	AO2L	A	Left SCART2 Audio Output
19	AO2R	A	Right SCART2 Audio Output
20	VDDH	AP	8 V / 5 V Power Supply for SCART & Audio Buffers



21	NC		Not Used
22	VREFA	A	Voltage Reference for Audio Buffers
23	AI3L	A	Left SCART3 Audio Input
24	AI3R	A	Right SCART3 Audio Input
25	N/C		Not Used
26	BGAP	A	Bandgap Voltage Source Decoupling
27	N/C		Not Used
28	LSL	A	Left Loudspeaker Output
29	LSR	A	Right Loudspeaker Output
30	SW	A	Subwoofer Output
31	HPL	A	Left Headphone Output
32	HPR	A	Right Headphone Output
33	GNDSA	AP	Substrate Analog/Digital Shield
34	N/C		Not Used
35	HPD	B	Headphone Detection Input (Active Low)
36	ADR	I	Hardware I <sup>2</sup> C Chip Address Control
37	N/C		Not Used
38	N/C		Not Used
39	SCL	OD	I <sup>2</sup> C Serial Clock
40	SDA	OD	I <sup>2</sup> C Serial Data
41	N/C		Not Used
42	REG	A	5 V Power Regulator Control
43	RESET	I	Hardware Reset (Active Low)
44	SYSCK	B	System Clock Output
45	MCK	B	I <sup>2</sup> S Master Clock Output
46	VDD1	DP	3.3V Power Supply for Digital Core & IO Cells
47	GND1	DP	0V Power Supply for Digital Core & IO Cells
48	N/C		Not Used
49	GNDSP	AP	Substrate Analog/Digital Shield for Clock-PLL
50	N/C		Not Used
51	N/C		Not Used
52	XTI	I	Crystal Oscillator Input
53	XTO	O	Crystal Oscillator Output

54	VDDP	AP	3.3 V Power Supply for Analog PLL Clock
55	GNDP	AP	0 V Power Supply for Analog PLL Clock
56	GND2	DP	0 V Power Supply for Digital Core, DSPs & IO Cells
57	VDD2	DP	3.3 V Power Supply for Digital Core, DSPs & IO Cells
58	CKTST	I	Must be Connected to 0 V
59	N/C		Not Used
60	N/C		Not Used
61	SDO	B	I <sup>2</sup> S Bus Data Output
62	ST/SDI	B	Stereo Detection Output / I <sup>2</sup> S Bus Data Input
63	WS	B	I <sup>2</sup> S Bus Word Select Output
64	SCK	B	I <sup>2</sup> S Bus Clock Output
65	BUS1	B	I <sup>2</sup> C Bus Expander Output 1
66	N/C		Not Used
67	N/C		Not Used
68	BUS0	B	I <sup>2</sup> C Bus Expander Output 2
69	IRQ	B	I <sup>2</sup> C Status Read Request
70	N/C		Not Used
71	N/C		Not Used
72	N/C		Not Used
73	SIF	A	Sound IF Input
74	VTOP	A	ADC VTOP Decoupling Pin
75	VREFIF	A	AGC Voltage Reference Decoupling Pin
76	VDDIF	AP	3.3 V Power Supply for IF AGC & ADC
77	GNDIF	AP	0 V Power Supply for IF AGC & ADC
78	MONOIN	A	Mono Input
79	NC		Not Used
80	NC		Not Used

### 3.5.3 Function introduction to MST718

#### 1. Description

The MST718BE is a high quality ASIC for NTSC/PAL/SECAM LCD-TV application. It receives analog NTSC/PAL/SECAM CVBS and S-Video inputs from TV tuners, DVD or VCR sources, including weak and distorted signals, as well as analog RGB input from GPS systems. Automatic gain control (AGC) and 10-bit

3-channel A/D converters provide high resolution video quantization. With automatic video source and mode detection, users can easily switch and adjust variety of signal sources. Multiple internal adaptive PLLs precisely extract pixel clock from video source and perform sharp color demodulation. Built-in line-buffer supports adaptive 2-D comb-filter, 2-D sharpening, and synchronization stabler in a condense manner. The output format of MST718BE supports 8-bit TTL or LVDS digital TFT-LCD modules.

## 2. FEATURES

- # Video Decoder
- # Supports NTSC, PAL and SECAM video input formats
- # 2D NTSC and PAL comb-filter for Y/C separation of CVBS input
- # Multiple CVBS and S-video inputs
- # Supports Closed-caption and V-chip
- # Supports Teletext 1.5
- # ACC, AGC, and DCGC (Digital Chroma Gain Control) Analog Input
- # Supports RGB input format from PC, camcorders and GPS
- # Supports YCbCr inputs from conventional video source and HDTV
- # Supports SCART – RGB + Fast Blank
- # Supports video input 480i, 480p, 576i, 576p, 720p, 1080i; RGB input resolution in 640x480, 800x480, 800x600, 1024x768, and 1280x1024(SXGA)
- # 3-channel low-power 10-bit ADCs integration for YCbCr and RGB
- # Supports RGB composite sync input (CSYNC), SOY, SOG, HSYNC, and VSYNC
- # On-chip clock synthesizer and PLL
- # Auto-position adjustment, auto-phase adjustment, auto-gain adjustment, and auto-mode detection
- ? Color Engine
- # Brightness, contrast, saturation, and hue adjustment
- # 9-tap programmable multi-purpose FIR (Finite Impulse Response) filter
- # Differential 3-band peaking engine
- # Vertical peaking
- # Spatial noise reduction
- # Luminance Transient Improvement (LTI)
- # Chrominance Transient Improvement (CTI)
- # Black Level Extension (BLE)
- # White Level Extension (WLE)
- # Favor Color Compensation (FCC)
- # 3-channel gamma curve adjustment
- # Independent 6 color of saturation, hue, and brightness contro
- # Scaling Engine/Panel Interface

- # Supports digital panels up to 1366x768, and 1440x900
- # Supports single/dual 8-bit LVDS panel outputs
- # Supports 8-bit TTL panel output
- # Supports various displaying modes
- # Supports horizontal panorama scaling? Miscellaneous
- # Built-in MCU
- # 3-wire serial bus interface for configuration setup
- # Built-in step-down PWM circuits for input 2.5V
- # Built-in internal OSD with 512 programmable fonts, 1、 2 or 4 bit per pixel color, 16-color palettes, and 12-bit color resolution
- # Supports external OSD
- # Support CVBS out
- # Spread spectrum clocks
- # Optional 3.3V / 5V output pads with programmable driving current
- # 128-pin PQFP package

### 3. PIN DESCRIPTION

Pin	Pin Name	Pin Type	Function
2	VMID		Mid-Scale Voltage Bypass
3	VCLAMP		CVBS/YC Mode Clamp Voltage Bypass
4	REFM		Internal ADC Bottom De-coupling Pin
5	REFP		Internal ADC Top De-coupling Pin
7	PRINP	Analog Input	Analog Pr Input of HDTV
8	PRINM	Analog Input	Reference Ground for Analog Pr Input of HDTV
9	PBINP	Analog Input	Analog Pb Input of HDTV
10	PBINM	Analog Input	Reference Ground for Analog Pb Input of HDTV
11	SOY	Analog Input	Sync-on-Y slicer input
12	YINP	Analog Input	Analog Y Input of HDTV
13	YINM	Analog Input	Reference Ground for Analog Y Input of HDTV
14	BINP	Analog Input	Analog B Input of VGA
15	BINM	Analog Input	Reference Ground for Analog B Input of VGA
16	SOGIN	Analog Input	Sync-on-Green slicer input
17	GINP	Analog Input	Analog G Input of VGA
18	GINM	Analog Input	Reference Ground for Analog G Input of VGA

19	RINP	Analog Input	Analog R Input of VGA
20	RINM	Analog Input	Reference Ground for Analog R Input of VGA
22	C1INP	Analog Input	Analog Chroma Input for TV S-Video1 / Analog Composite Input of TV CVBS4
23	C1INM	Analog Input	Reference Ground for Analog Chroma Input of TV S-Video1 / Analog Composite Input of TV CVBS4
24	YS1INP	Analog Input	Analog Luma Input of TV S-Video1 / Analog Composite Input of TV CVBS3
25	YS1INM	Analog Input	Reference Ground for Analog Luma Input of TV S-Video1 / Analog Composite Input of TV CVBS3
26	C2INP	Analog Input	Analog Chroma Input for TV S-Video2
27	C2INM	Analog Input	Reference Ground for Analog Chroma Input of TV S-Video2
28	YS2INP	Analog Input	Analog Luma Input of TV S-Video2
29	YS2INM	Analog Input	Reference Ground for Analog Luma Input of TV S-Video2
30	CVBS1P	Analog Input	Analog Composite Input for TV CVBS1
31	CVBS1M	Analog Input	Reference Ground for Analog Composite Input of TV CVBS1
32	CVBS2P	Analog Input	Analog Composite Input for TV CVBS2
33	CVBS2M	Analog Input	Reference Ground for Analog Composite Input of TV CVBS2
116	VREXT_CDAC	Analog Input	Reference Current Generator, 820 ohm to Ground
125	HSYNCIN1	Schmitt Trigger Input w/ 5V-tolerant	HSYNC / Composite Sync for VGA Input 1
124	VSYNIN1	Schmitt Trigger Input w/ 5V-tolerant	VSYN for VGA Input 1
123	HSYNCIN2	Schmitt Trigger Input w/ 5V-tolerant	HSYNC / Composite Sync for VGA Input 2
122	VSYNIN2	Schmitt Trigger Input w/ 5V-tolerant	VSYN for VGA Input 2
Digital Panel Output Interface			
Pin	Pin Name	Pin Type	Function
77	CLKO	Output	Display Clock Output
78	DEO	Output	Display Enable Output
79	VSYNCO	Output	Vertical Sync Output
80	HSYNCO	Output	Horizontal Sync Output
108	BOUT[7]/LVB0M	Output	Blue channel Output [7] / LVDS B-Link Channel 0 Negative Differential Data Output

107	BOUT[6]/LVB0P	Output	Blue channel Output [6] / LVDS B-Link Channel 0 Positive Differential Data Output
106	BOUT[5]/LVB1M	Output	Blue channel Output [5] / LVDS B-Link Channel 1 Negative Differential Data Output
105	BOUT[4]/LVB1P	Output	Blue channel Output [4] / LVDS B-Link Channel 1 Positive Differential Data Output
104	BOUT[3]/LVB2M	Output	Blue channel Output [3] / LVDS B-Link Channel 2 Negative Differential Data Output
103	BOUT[2]/LVB2P	Output	Blue channel Output [2] / LVDS B-Link Channel 2 Positive Differential Data Output
102	BOUT[1]/LVBCKM	Output	Blue channel Output [1] / LVDS B-Link Negative Differential Clock Output
101	BOUT[0]/LVBCKP	Output	Blue channel Output [0] / LVDS B-Link Positive Differential Clock Output
99	GOUT[7]/LVB3M	Output	Green channel Output [7] / LVDS B-Link Channel 3 Negative Differential Data Output
98	GOUT[6]/LVB3P	Output	Green channel Output [6] / LVDS B-Link Channel 3 Positive Differential Data Output
97, 96	GOUT[5:4]	Output	Green channel Output [5:4]
95	GOUT[3]/LVA0M	Output	Green channel Output [3] / LVDS A-Link Channel 0 Negative Differential Data Output
94	GOUT[2]/LVA0P	Output	Green channel Output [2] / LVDS A-Link Channel 0 Positive Differential Data Output
93	GOUT[1]/LVA1M	Output	Green channel Output [1] / LVDS A-Link Channel 1 Negative Differential Data Output
92	GOUT[0]/LVA1P	Output	Green channel Output [0] / LVDS A-Link Channel 1 Positive Differential Data Output
91, 90	ROUT[7:6]	Output	Red channel Output [7:6]
89	ROUT[5]/LVA2M	Output	Red channel Output [5] / LVDS A-Link Channel 2 Negative Differential Data Output
88	ROUT[4]/LVA2P	Output	Red channel Output [4] / LVDS A-Link Channel 2 Positive Differential Data Output
87	ROUT[3]/LVACKM	Output	Red channel Output [3] / LVDS A-Link Negative Differential Clock Output
86	ROUT[2]/LVACKP	Output	Red channel Output [2] / LVDS A-Link Positive Differential Clock Output
85	ROUT[1]/LVA3M	Output	Red channel Output [1] / LVDS A-Link Channel 3 Negative Differential Data Output
84	ROUT[0]/LVA3P	Output	Red channel Output [0] / LVDS A-Link Channel 3 Positive Differential Data Output
External OSD Interface			
Pin	Pin Name	Pin Type	Function
73	OSDR/GPIO_P30	I/O w/ 5V-tolerant	DVD clock signal(DVSCK)

74	OSDG/GPIO_P31	I/O w/ 5V-tolerant	Display screen working power control pin (PANELON)
75	OSDB/GPIO_P32	I/O w/ 5V-tolerant	Software program protection control pin (24WP)
76	FB/GPIO_P33	I/O w/ 5V-tolerant	Boost board control (INVERTERON/OFF)
Switching Power and PWM Interface			
Pin	Pin Name	Pin Type	Function
38	PWMOUT2	Output	Switching Pulse Output for DC-DC Converter (NC)
39	FB2	Analog Input	Error Voltage Feedback Input Pin for PWM2; voltage = 1.2V (NC)
40	SENSE2	Analog Input	Sense Circuit Connection for PWM2 (NC)
41	PWMOUT1	Output	Switching Pulse Output for DC-DC Converter (NC)
42	FB1	Analog Input	Error Voltage Feedback Input Pin for PWM1; voltage = 1.2V (NC)
43	SENSE1	Analog Input	Sense Circuit Connection for PWM1 (NC)
44	PGOOD	Output	Power Good Indicator (NC)
Internal MCU Interface with Serial Flash Memory			
Pin	Pin Name	Pin Type	Function
49	SAR2	Analog Input	Connect pull-up resistor externally
48	SAR1	Analog Input	Button control input
47	SAR0	Analog Input	Button control input
52	SCK	Output	SPI Interface CLOCK-In (SPICK)
53	SDI	Output	SPI Interface Data-In (SPIDI)
54	SDO	Input w/ 5V-tolerant	SPI Interface Data-Out (SPIDO)
55	CSN	Output	SPI Interface Chip Select (SPICZ)
58-64, 83	GPIO_P00-GPIO_P07	I/O w/ 5V-tolerant	MCU control jack (IIC bus, connect with the serial input line of CD4094)
65	INT	Input	Interrupt Input for IR Receiver
66	SDA	I/O w/ 5V-tolerant	3-Wire Serial Bus Data
67	SCL	Input w/ 5V-tolerant	3-Wire Serial Bus Clock
68	POWER_ON_RSTN/ CS	Input w/ 5V-tolerant	Power On Reset Signal/Chip Selection for 3-wire Serial
Misc. Interface			
Pin	Pin Name	Pin Type	Function
72	RESET	Schmitt Trigger Input w/ 5V-tolerant	Hardware Reset; active high

121	XIN	Analog Input	Crystal Oscillator Input
120	XOUT	Analog Output	Crystal Oscillator Output
56	GPIO_P24/PWMD3	Output	Software protection control signal jack
57	GPIO_P25/PWMD4	Output	Standby control output end
70	PWMD2	Output	NC
71	PWMD1	Output	NC
100	INT_OUT	Output	NC
34, 115	CVBSO1/CVBSO2	Output	Analog Composite Output for TV CVBS1/CVBS2
109	MCUSEL	Input	Embedded MCU selection. 0: MCU on. 1: MCU off.
6, 21	AVDD_ADC	2.5V Power	ADC Power
35	AVDD_GMC	5V Power	GMC Power
37	AVDD_PWM	5V Power	PWM Power
113	AVDD_OPLL	2.5V Power	OPLL Power
117	AVDD_CDAC	2.5V Power	Current DAC Power
118	AVDD_XTAL	5V Power	XTAL Power
127	AVDD_MPLL	2.5V Power	MPLL Power
50, 110	VDDC	2.5V Power	Digital Core Power
46, 82	VDDP	3.3V/5V Power	Digital Input/Output Power
1, 36, 45, 51, 69, 81, 111, 112, 114, 119, 126, 128	GND	Ground	Ground

### 3.5.4 function introduction to CD4052

#### 1. Description

The CD4052B (u107) analog multiplexers is digitally-controlled analog switches having low ON impedance and very low OFF leakage current. Control of analog signals up to 20VP-P can be achieved by digital signal amplitudes of 4.5V to 20V (if VDD-VSS = 3V, a VDD-VEE of up to 13V can be controlled; for VDD-VEE level differences above 13V, a VDD-VSS of at least 4.5V is required). For example, if VDD = +4.5V, VSS = 0V, and VEE = -13.5V, analog signals from -13.5V to +4.5V can be controlled by digital inputs of 0V to 5V. These multiplexer circuits dissipate extremely low quiescent power over the full VDD-VSS and VDD-VEE supply-voltage ranges, independent of the logic state of the control signals. When a logic “1” is present at the



inhibit input terminal, all channels are off.

The CD4052B is a differential 4-Channel multiplexer having two binary control inputs, A and B, and an inhibit input. The two binary input signals select 1 of 4 pairs of channels to be turned on and connect the analog inputs to the outputs.

## 2. FEATURES

### # Wide Range of Digital and Analog Signal Levels

Digital: 3V to 20V

Analog: 20VP-P

### # Low ON Resistance, 125Ω (Typ) Over 15VP-P Signal Input Range for $V_{DD}-V_{EE} = 18V$

### # High OFF Resistance, Channel Leakage of $\pm 100pA$ (Typ) at $V_{DD}-V_{EE} = 18V$

### # Logic-Level Conversion for Digital Addressing Signals of 3V to 20V ( $V_{DD}-V_{SS} = 3V$ to 20V) to Switch Analog Signals to 20VP-P ( $V_{DD}-V_{EE} = 20V$ )

### # Matched Switch Characteristics, $r_{ON} = 5\Omega$ (Typ) for $V_{DD}-V_{EE} = 15V$

### # Very Low Quiescent Power Dissipation Under All Digital-Control Input and Supply Conditions, 0.2mW (Typ) at $V_{DD}-V_{SS} = V_{DD}-V_{EE} = 10V$

### # Binary Address Decoding on Chip

### # 5V, 10V and 15V Parametric Ratings

### # 10% Tested for Quiescent Current at 20V

### # Maximum Input Current of 1mA at 18V Over Full Package Temperature Range, 100nA at 18V and 25

### # Break-Before-Make Switching Eliminates Channel Overlap

## 3. Pin Definitions

Pin	Name	Function	I/O
1, 2, 4, 5	Y0-Y3	Y signal input	I
11, 12, 14, 15	X0-X3	X signal input	I
3, 13	Y	Y signal output	O
6	INH	Two groups have no output when two ends are high level	I
7	VEE	-12V power (grounding)	
8	VSS	ground	
16	VDD	+5V power	
9, 10	B, A	Strobe signal	I
13	X	X signal output	O

### 3.5.5 function introduction to TDA7266D

#### 1. FEATURES

# WIDE SUPPLY VOLTAGE RANGE (3.5 - 12V)

# OUTPUT POWER

5+5W @THD = 10%,  $R_L = 8\Omega$  ,  $V_{CC} = 9.5V$

# SINGLE SUPPLY

# MINIMUM EXTERNAL COMPONENTS

- NO SVR CAPACITOR
- NO BOOTSTRAP
- NO BOUCHEROT CELLS
- INTERNALLY FIXED GAIN

# STAND-BY & MUTE FUNCTIONS

# SHORT CIRCUIT PROTECTION

# THERMAL OVERLOAD PROTECTION

#### 2. PIN CONNECTION

SN	Name	Pin function	SN	Name	Pin function
1	OUT1+	Audio output +	9	S-GND	Ground wire
2	OUT1-	Audio output -	10	NC	NC
3	VCC	Power input	11	NC	NC
4	IN1	Audio input	12	IN2	Audio input2
5	NC	NC	13	VCC	Power input
6	MUTE	Mute control	14	OUT2-	Audio output-
7	ST-BY	Standby control	15	OUT+	Audio output +
8	PW-GND	Ground wire			

### 3.5.6 function introduction to FSAV433

#### 1. Description

The FSAV433 is an ultra low power high bandwidth video switch specially designed for the switching of three analog video signals, including computer RGB and high definition YPbPr signals.

The wide bandwidth (550MHz) of this switch allows signal passage with minimum edge and phase distortion while 70Db non-adjacent channel crosstalk generates negligible image noise between active channels. Optimized differential gain and differential phases maintain the image integrity of video applications while low On Resistance offers low signal insertion loss.

## 2. Pin Descriptions

Pin Name	Description	Pin Name	Description
OE	Bus Switch Enable	A	Bus A
S1, S2	Select Input	B1–B3	Bus B

## 3. Truth Table







S1	S2	Function	H	L	A = B2
L	L	Disconnect	H	H	A = B3
L	H	A = B1			

## 3.5.7 function introduction to HEF4094B

### 1. DESCRIPTION

The HEF4094B is an 8-stage serial shift register having a storage latch associated with each stage for strobing data from the serial input to parallel buffered 3-state outputs O<sub>0</sub> to O<sub>7</sub>. The parallel outputs may be connected directly to common bus lines. Data is shifted on positive-going clock transitions. The data in each shift register stage is transferred to the storage register when the strobe (STR) input is HIGH. Data in the storage register appears at the outputs whenever the output enable (EO) signal is HIGH. Two serial outputs (O<sub>s</sub> and O'<sub>s</sub>) are available for cascading a number of HEF4094B devices. Data is available at O<sub>s</sub> on positive-going clock edges to allow high-speed operation in cascaded systems in which the clock rise time is fast. The same serial information is available at O'<sub>s</sub> on the next negative-going clock edge and provides cascading HEF4094B devices when the clock rise time is slow.

### 2. FUNCTION TABLE

INPUTS				PARALLEL OUTPUTS		SERIAL OUTPUTS	
CP	EO	STR	D	O <sub>0</sub>	O <sub>n</sub>	O <sub>s</sub>	O' <sub>s</sub>
	L	X	X	Z	Z	O' <sub>6</sub>	nc
	L	X	X	Z	Z	nc	O <sub>7</sub>
	H	L	X	nc	nc	O' <sub>6</sub>	nc
	H	H	L	L	O <sub>n-1</sub>	O' <sub>6</sub>	nc
	H	H	H	H	O <sub>n-1</sub>	O' <sub>6</sub>	nc
	H	H	H	nc	nc	nc	O <sub>7</sub>

#### Notes:

1. H = HIGH state (the more positive voltage)

2. L = LOW state (the less positive voltage)
3. X = state is immaterial
4. = positive-going transition
5. = negative-going transition
6. Z = high impedance off state
7. nc = no change
8. O'6 = the information in the seventh shift register stage

## Section Three Servicing and Principle

### The next manual: DVD part

#### Section One Principle of the player

##### 3.1.1 Introduction to the player

Electronic scheme of LD2006SI-2 adopts LCD components (LC201V02-SDB1 20" )+inverter components (INV607)+MST518VA+TVP5146M1+STV8216+TDA7266P+tuner JS-6B2/121+CPU (W79E632A40PN ), which support PAL BG/DK/I, SECAM BG/DK/L/L' RF signal modulating, PAL/NTSC/SECAM/PAL60 multi-system video signals, BG/DK/I/LL/L' accompanying system's FM, NICAM, A2 Stereo signal modulating and accompanying restore and external input SCART S-VIDEO composite video input mode. This model is composed of power, boost components, power switch board, main board, button board and remote control receiving board.

##### 3.1.2 Introduction to IC used by the player

SN	Material code	Material name	Specs & Model	Qty	Position Number	Function
1	882644	IC	MT1389FE/H(HD EDITION) QFP	1	U115	DVD decode chip
2	880768	IC	C4558 SOP	1	U117	DVD audio amplifying
3	881378	IC	BA5954FP HSOP	1	U118	Servo drive IC
4	881604	IC	AT24C16 SOP	1	U303	DVD EEPROM
5	911958	Software program	ROMLD2006SI2-0A(16M)	1	U302	DVD software program

## Section Two Unit Circuit Principle

### 3.2.1 Introduction to laser head

Function introduction to laser head flat cable is shown as the following table:

Pin	Name	Signal flow direction	DVD disc	CD disc	No disc	Function description
1	F-	Input loader	2.52	2.34	0.46	Focus error signal is added to two sides of pick-up focus coil
2	F+	Input loader	2.49	2.49	0.93	
3	T+	Input loader	2.53	2.51	0.94	Trace error signal is added to two sides of pick-up trace coil
4	T-	Input loader	2.58	2.51	0.93	
5	C	Input MT1389	2.2	2.25	2.04	Disc data signal
6	D	Input MT1389	2.2	3.2	2.04	Disc data signal
7	IOA	Input MT1389	0.01	3.2	3.21	Disc identification signal, CD is 3.3V, DVD is 0V
8	RF	Input MT1389	2.21	2.53	1.28	The sum of disc data signal
9	A	Input MT1389	2.17	2.22	2.04	Disc data signal
10	B	Input MT1389	2.19	2.27	2.04	Disc data signal
11	F	Input MT1389	2.07	2.44	2.03	Supplementary signal used in trace
12	GND	Ground	0.01	0.01	0	Grounding
13	V20	Input loader	2.04	2.06	2.03	Reference voltage
14	Vcc	Input loader	5.04	5.04	5.02	Supply voltage for loader
15	E	Input MT1389	2.06	2.45	2.03	Disc data signal
16	Blanking	hanging in air	0.01	0	0	unused
17	VR-CD	Input loader	0.21	0.01	0	Through the handling inside loader, make sure MD11 is 180mV when reading CD
18	VR-DVD	Input loader	0.01	0.2	0	Through the handling inside loader, make sure MD11 is 180mV when reading DVD
19	LD-CD	Input loader	0.09	2.1	0	CD laser power control signal
20	MDII	Input MT1389	0.21	0.2	0	CD and DVD laser power monitoring signal

21	HFM	Input loader	5.04	5.04	5.02	High frequency overlapping signal produces laser with different wave length inside loader
22	Blanking	unused	0.01	0.1	0	
23	LD-DVD	Input loader	2.21	0.1	0	DVD laser power control signal
24	GND	unused	0.01	0.01	0	Grounding

Note: 1) When reading DVD, there are only A, B, C, D signals.

2) When reading CD, there are A, B, C, D, E, F signals.

3)  $RFO=A+B+C+D$ .

4) Focus error signal= $(A+C)-(B+D)$  Trace error signal= $E-F$ .

## 2. Working principle

(1) Laser tube: wave length of loader DVD laser diode is 650nm, wave length of CD laser diode is 790nm, the wave length which is within 370nm and 750nm is visible light, the laser in the course of reading DVD disc is visible light, and that when reading CD disc is infrared light.

(2) Principle about laser head picks up signal: laser beam projects onto disc, when laser beam focus projects onto disc vertically, laser beam will produce reflection, reach on light sensor through reflection loop and converse into electronic signal through photoelectric cell. For the reflection loop produced in non pit information area and pit information area in disc has difference and reflects into different position of light sensor, photoelectric diode in different positions on light sensor will produce different signals to process all signals on light sensor and then produce digital signals.

(3) Focus, trace coil: when laser head is reading signals normally, information side should be in the focus of laser beam, because of factors of disc error, high speed rotation and machine error, it is unavoidable that laser beam focus deviates from information face to produce phenomena of orbit boas and refocusing. Focus , trace coil is added on loader to adjust laser beam to make it correctly focus in information area.

(4) Formation of RF signal: when disc reading is normal, light sensor will have 160MV, vague and eye pattern waveform which is added on A, B, C, D respectively, and output RF signal from FRO pin after being overlapped by adder inside light sensor, the frequency when reading DVD disc is much higher than that when reading CD disc, output amplitude is about 1.4V.

## 3.2.2 Servo circuit

1. Servo system of this player adopts SANYO loader + MTK decode solution (MT1389HD+FLASH(16M) + SDRAM (64M)), and its servo circuit is mainly composed of front end signal Processing, digital Servo processing, digital signal processing IC MT1389HD and drive circuit D5954, in which MT1389HD is also the main composed part of decode circuit. Servo circuit block diagram is shown as in the following figure 3.2.2.1:

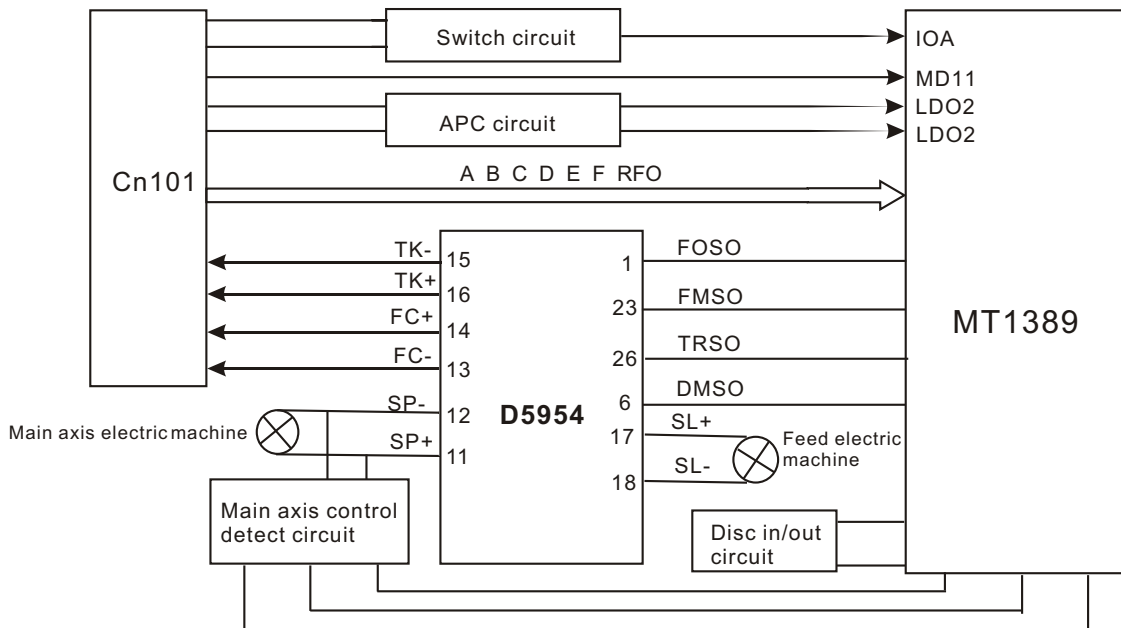

Figure 3.2.2.1 Servo circuit block diagram

## 2. Working principle

After power on, machine displays "OPEN". After loading disc, loader pick-up begins to reset. After pick-up goes to the proper position, detect switch will give a signal to MT1389, MT1389 begins to output focus, main axis and laser signals, disc begins rotating and pick-up begins to identify disc information and judge whether disk is CD disc or DVD disc according to disc information in order to output level from pin IOA and control disc switch circuit and pick-up PD IC to make the corresponding action, meanwhile Mt1389 adjusts laser output power through laser power control circuit.

After loader reads disc information, A, B, C, D, E and F signal are formed through photoelectric conversion to MT1389 (DVD only has A, B, C, D signals) and RF signal and output from pin 2~11, 18, 19 of MT1389 respectively, after amplifying processing of pre-amplifier inside MT1389, now signals are divided into 2 ways inside MT1389: one part, through summation amplifying and subtraction circuit inside MT1389, produces servo error signal, after digital servo signal circuit processing, forms corresponding servo control signals, outputs FOO, TRO, DMO and FMSO servo control signal from pin 42, 41, 37 and 38 of MT1389 respectively and then send to servo drive circuit for drive amplifying through the integration circuit composed by resistor and capacitor and bring along focus coil, trace coil, main axis Electric machine and feed electric machine after drive amplifying. Among these, focus and trace servo are used to correct objective position accurately; feed servo is used to bring along laser head to make radial large-scale move which belongs to the preliminary adjustment to laser head position; and main axis servo is used to control main axis electric machine to make it read signals in means of constant Linear velocity and bring along disc to rotate. After processing of amplification by VGA voltage control amplifier and Equalization frequency compensation inside MT1389, another part of signals are changed into digital signals through internal A/D converter. When loader is reading CD/VCD signals, these signals are



Conducted EFM demodulation inside MT1389, and then outputted to latter stage for AV decoding after finishing CIRC (Cross-Interleaved Reed-Solomon Code) error correction inside. When loader is reading DVD signals, these signals are conducted ESM demodulation inside MT1389, and then sent to latter stage for decoding after finishing RSPC error correction inside. General DVD players have a disc in/out circuit to control disc tray door in/out acts to reach the purpose of making disc in and out. For PDVD, we adopt manual disc in/out means and we can judge whether disc in to proper position through detect switch.

### 3. Explanation to servo terms

(1) FOO: for disc make differences, and when rotating disc may probably move upwards or downwards slightly to make the focus of laser emitted by laser head cannot justly fall on data pit of disc, now focus point of objective lens is required to adjust to make focus aim at data pit exactly. The acts are mainly to make objective lens move upwards and downwards.

(2) TRO: data information is saved in disc in form of tracks. When disc is rotating, disc deviation will produce, now laser head is required to adjust. In this process, objective lens makes forward and backward movement with small moving range.

(3) FMO: similar to acts of trace, the acts of feed are larger than those of trace. Feed conducts a large scale movement firstly, and then trace moves slightly in this range. Feed moves for a while, and does not move for another while; but trace moves all the time. Feed is rough adjustment and trace is fine. And acts are obvious when power on and selecting track.

(4) DMO: it is the top that holds up disc. Its rotation speed decides that of disc. Its rotation is generated by an individual DC electric machine, in which rotation speed of DVD is twice over that of CD.

### 3.2.3 Laser power control circuit

1. Laser power control circuit is shown as in the following figure 3.2.3.1:

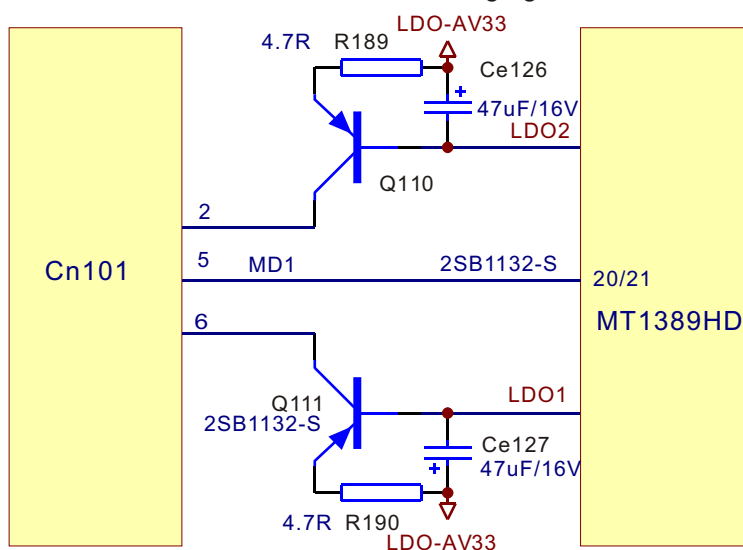

Figure 3.2.3.1 Laser power control circuit diagram

## 2. Working principle

Pin 20/21 of MT1389 is laser power detect signal input pin, pin 21 is DVD laser power strong/weak detect signal input pin, pin 23 is VCD laser power drive control output pin, pin 22 is DVD laser power drive control output pin.

When reading VCD disc, laser power becomes weak, voltage of MDII pin decreases, voltage decrease of pin 23 of MT1389 makes voltage of pin 6 of Cn101 increase to reach the purpose of raising laser power. When laser power is too strong, voltage of MDII pin increases to lead to voltage of pin 23 of MT1389 increase to make voltage of pin 6 of CN101 decrease to reach the purpose of reducing laser power to form an auto power control circuit.

When reading DVD disc, pin 21 is detect signal input pin, pin 22 is drive control input pin, and the working principle is the same with that when playing VCD disc.

3. Key point voltage (unit: V) is shown as the following table:

Location number	Read DVD disc	Read VCD disc	Location number	Read DVD disc	Read VCD disc
Q110_E	2.9V	3.2V	Q111_B	3.2V	2.2V
Q110_B	2.2V	3.2V	Q111_E	3.2V	2.9V
Q110_C	2.2V	0	MT1389_20	0.2V	0.2V
Q111_C	0	2.2V			

## 3.2.4 CD/DVD conversion circuit

1. CD/DVD conversion circuit is shown as in the following figure 3.2.4.1:

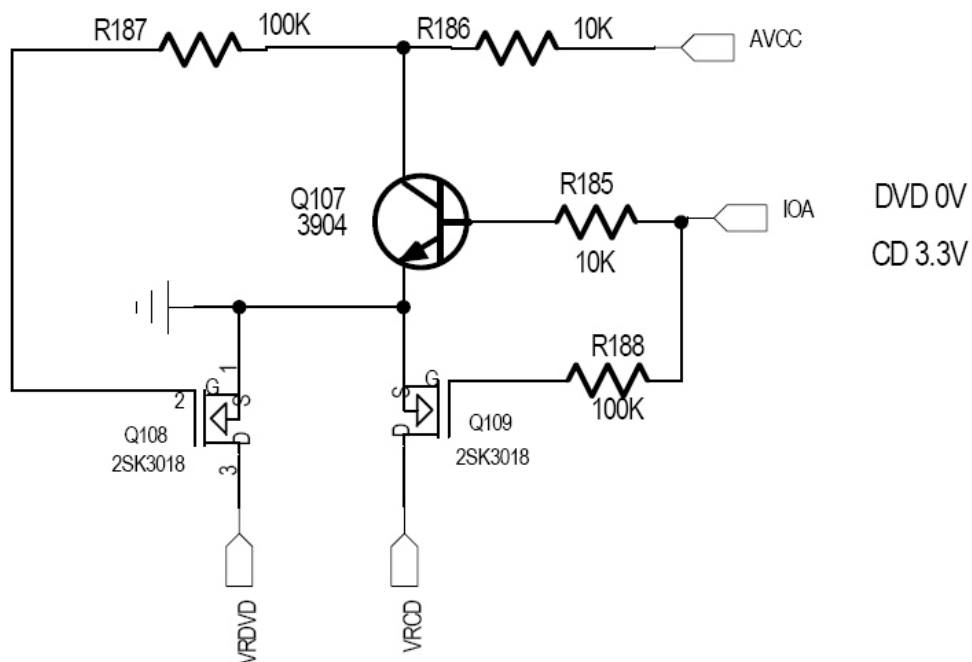

Figure 3.2.4.1 CD/DVD conversion circuit diagram

## 2. Working principle

After loading disc in the player, IOA port of MT1389 is defaulted high level to make Q107 saturation on and form loop together with CD laser power control circuit on CD. At the same time, IOA also goes to loader PD IC to switch, disc begins to rotate, when servo management system recognizes that the disc in player is not CD disc, IQA pin outputs low level to make Q107 cut off and make Q108 on, and form loop together with DVD laser power control circuit on loader to perform disc reading acts. After disc tray door opens, IOA keeps the state before opening disc tray door. If the player cannot recognize which disc it is, IQA pin will switch continuously until reading disc or system judges that there is no disc.

Note: Q108 and Q109 are MOS tube

3. Key point voltage (unit: V) is shown as the following table:

State	Q107			Q108			Q109			IOA
	Base electrode B	Collector C	Emitter E	Grid electrode G	Drain electrode D	Source electrode S	G	D	S	
DVD disc	0	3.86	0	3.81	0.18	0	0	0	0	0
VCD disc	0.64	0.1	0	0	0	0	3.27	0.18	0	3.3

### 3.2.5 Disc slot-in circuit

LD1506S adopts dual slot-in and sealed-style all-steel with compact structure. There is a all-steel disc pressing system, in which disc is tightly pressed through 3 small steel plates, thus it is applicable to those discs with problem. It is really full-compatible with reading 12cm large disk and also 8cm small disk. The player adopts light induction style to read disk. As long as you place the disc on the door, the loader will absorb it in automatically.

1. Disc slot-in circuit is shown in the figure 3.2.5.1:

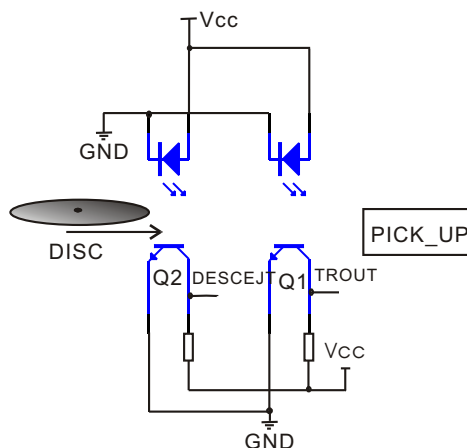

Figure 3.2.5.1 Disc slot-in circuit diagram

2. Working principle: there are two light emission fluorescent tubes on top of the opening of slot-in loader disk and there are two photoelectric tubes at bottom on two ends of disc opening. After loading a disk, the disk holds up the light emitted from light emission tube to make the corresponding photoelectric Diode (Q2) of this light emission tube cannot receive lights. Detect signal DISCEJT on loader outputs high level to decode board. When DISCEJT pin of Mt1389 detects that DISCEJT signal is high level, output disc tray in control signal. After disc tray enters to proper position, mechanical structure of loader touches disc tray in switch, TRIN becomes high level from low level, decode chip stops outputting disc tray in signals and machine begins to read disc. When disc tray is out, transmission structure conveys disc outwards. When disc passes through the detecting of the photoelectric tube (Q1) inside loader, after disc is out to the appointed position, TROUT becomes low level and disc tray out stops.

Note: in order to understand more simply, this schematic diagram has some difference from real circuit, so please note.

### 3.2.6 Disc in/out circuit

1. Disc in/out circuit is shown as the following figure 3.2.6.1:

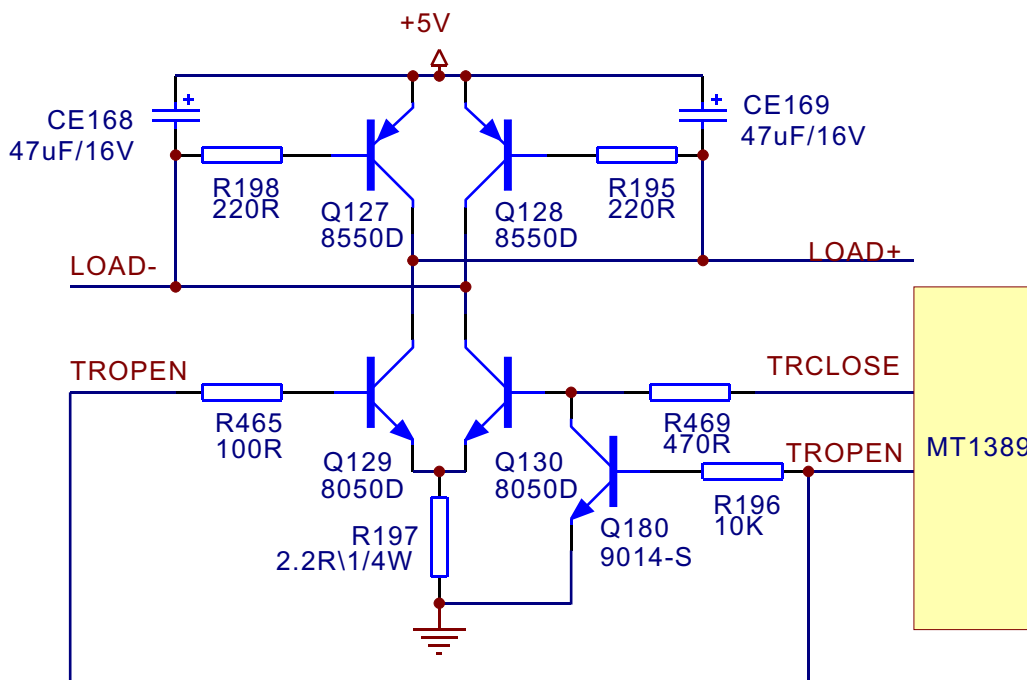

Figure 3.2.6.1 Disc in/out circuit diagram

2. Working principle: INDISC, OUTDISI are disc in/out control signals and are connected to pin 39, 54 of U201 (MT1389) respectively. LOAD+, LOAD- connect with two ends of electric machine to control. When users are performing disc out operation, servo control chip U201 (MT1389) sends out control signal through pin 39, 54 and changes level of LOAD+, LOAD- to change the rotation direction of electric

Machine to realize disc in/out function. The working process of disc in/out circuit is shown as follows:

OUT disc : VCC-Q127CE electrode on-LOAD+ -Electric machine-LOAD- -Q130CE electrode on-R197-Ground.

When not opening disc tray, pin 39 and 54 of U201 (MT1389) are low level. When opening disc tray, pin39 of U201 (MT1389) sends a high level; Q130 is on; Q130 collector electrode changes into low level; LOAD- changes into low level; Q127 base electrode changes into low level; Q127 is on. Q127 collector electrode changes into high level and LOAD+ changes into high level.

IN disc: VCC-Q128CE electrode on-LOAD- -Electric machine-LOAD+ -Q129CE electrode on-R197-Ground

When closing disc tray, pin 54 of U201 (MT1389) sends a high level; Q129 is on; collector electrode changes into low level; LOAD+ is low level; base electrode through R230 and Q128 is low level; Q128 is on; Q128 collector electrode changes into high level; LOAD- changes into high level.

The function of Q180 is interlock IN DISC and OUT DISC signal to ensure the two are not high level at the same time. When the two are high level input, base electrode of Q130 is made to low level through Q180 on to ensure the normal working of disc in/out circuit. The function of electrolytic capacitor CE168 and TC307 is to avoid the sudden change of the voltage on two ends of disc in/out electric machine to make disc in/out acts smooth.

3. Key point voltage (unit: V) is shown as the following table:

State	Q127			Q128		
	Base electrode B	Collector C	Emittor E	Base electrode B	Collector C	Emittor E
Read disc	5.06	5	5.06	5.01	5.03	5.06
Open disc tray to proper position	4.79	4.77	5.06	4.77	4.79	5.06
Open disc tray	4.74→5.05→4.74	4.76→0.2→4.76	5.06	4.76→4.33→4.76	4.76→5.02→4.76	5.06
Close disc tray	4.74→4.33→4.74	4.76→5.05→4.76	5.06	4.76→5.03→4.76	4.79→0.2→4.79	5.06
State	Q129			Q130		
	Base electrode B	Collector C	Emittor E	Base electrode B	Collector C	Emittor E
Read disc	0	5	0	0	5.03	0
Open disc tray to proper position	0	4.77	0	0	4.79	0
Open disc tray	0→0.93→0	4.76→0.2→4.76	0	0	4.79→5.02→4.79	0
Close disc tray	0	4.76→5.05→4.76	0	0→0.93→0	4.79→0.2→4.79	0
State	Q180			OUT	IN	
	Base electrode B	Collector C	Emittor E			
Read disc	0	0	0	0	0	

Open disc tray to proper position	0	0	0	0	0	
Open disc tray	0→0.63→0	0	0	0→3.12→0	0	
Close disc tray	0	0→0.93→0	0	0	0→3.12→0	

### 3.2.7 Main axis control circuit

1. Main axis control circuit is shown as in the following figure 3.2.7.1:

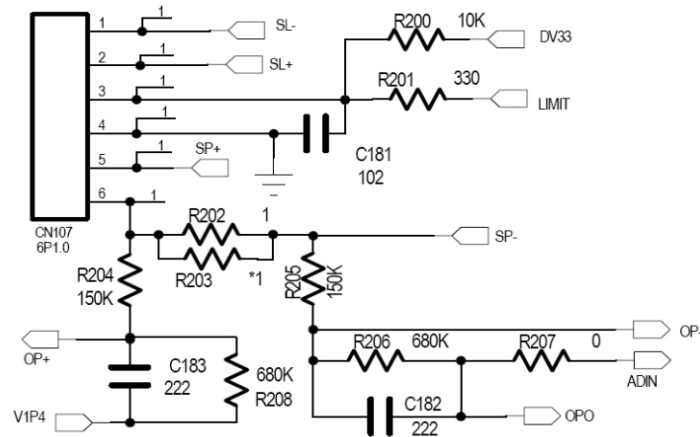

Figure 3.2.7.1 Main axis control circuit diagram

2. Function: disc is always in high speed rotation in the course of disc reading, when you need to open the door to change disc, MT1389 stops the positive direction drive signal which is given to main axis drive circuit, for the function of inertia disc is still rotating. If disc out order is performed at this time, disc will be abrasively damaged. Therefore, machine must be baking to main axis, that whether disc has stopped rotating and whether disc is reversing, decode chip of the machine cannot recognize. So a main axis control circuit is added to make decode chip can effective monitor that whether disc has stopped rotating.

3. Working principle: MT1389 has a comparator inside composed of operational amplifier, in which OP+ is the in-phase input end of operational amplifier, OP- is reverse input end, OPO is output end, when playing disc normally, for electric machine is positive direction rotating, voltage of OP+ is higher than that of OP-, voltage of OPO is more than 1.4V. When disc out is needed, main axis drive signal stops, for electric machine is permanent magnetic, when in rotating, induced electromotive force produces in two ends to give to decode chip through R204, R205 sampling to make OPO output less than 1.4V voltage and transmit to input pin of MT1389 ADIN through R207. When ADIN is high level, main axis drive output end has not any drive signal output, when ADIN is low level, MT1389 outputs a reversing drive signal to main axis drive circuit to make main axis electric machine speed down. Thus circular working goes on until main axis stops rotating. PDVD is manual disc out means, so after disc out, disc is still rotating, but will stop very son.

4. Key point voltage (unit: V) is shown as the following table:

Key point	Position	Normal working voltage (V)	Volateg change when disc out (V)
SP+	Pin 11 of D5954, pin 6of cn107	3.79	3.79→0.70→1.80
SP-	Pin 12 of D5954, pin 5 of cn107	1.38	1.38→3.40→1.80
OP+	Pin 36 of MT1389	1.38	1.38→3.10→1.80
OP-	Pin 35 of MT1389	1.53	1.53→3.08→1.98
OPO	Pin 34 of MT1389	2.44	2.44→0.40→2.50
ADIN	Pin 50 of MT1389	2.44	2.41→0.41→2.44
DMSO	Pin 5 of D5954	1.42	1.42
VIP4	Pin 30 of MT1389	1.41	1.41

### 3.2.8 Decode circuit

1. Decode circuit block diagram is shown as in the following figure 3.2.8.1:

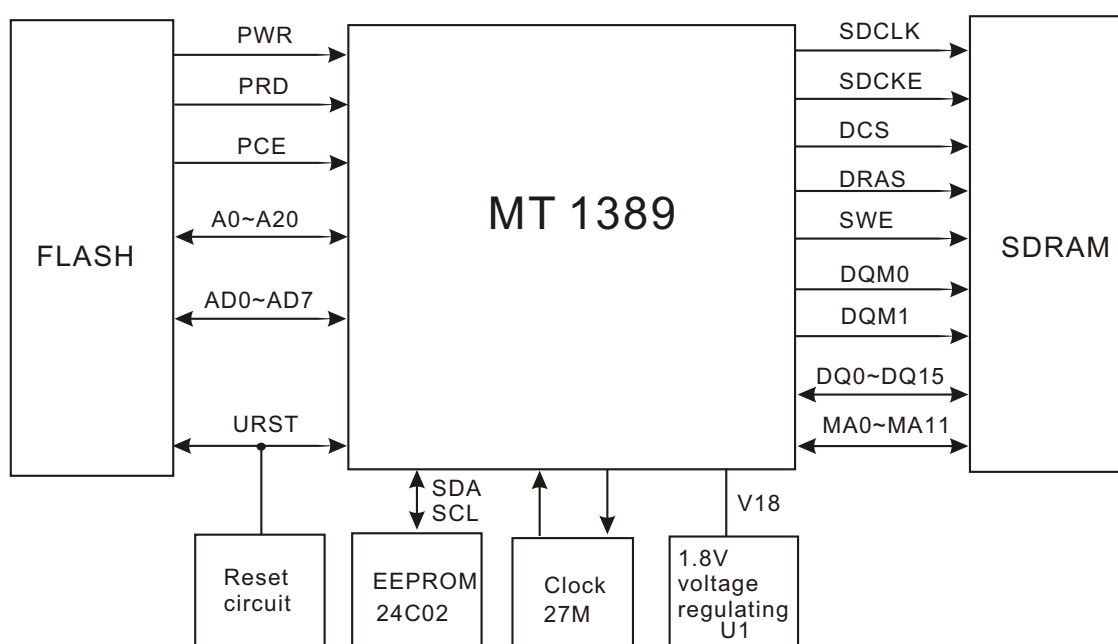

Figure 3.2.8.1 Decode circuit block diagram

2. Working principle: this decode circuit is mainly composed of MT1389, SDRAM and FLASH.

Working condition of decode circuit has:

(1) Reset: refer to reset circuit working principle for details.

(2) Clock: this system adopts 27M external clock input, and produces clock signal required by system inside through internal frequency doubling circuit.

(3) Power: decode chip adopts two groups power supply of 3.3V and 1.8V, in which 1.8V mainly supply power for internal logic control circuit and we call it core voltage.

After power on, reset circuit performs reset to MT1389 built-in CPU (8032) and FLASH, decode chip outputs reset signal at the same time and performs reset to other circuit. After system reset, it firstly sends out read signal to FLASH to read out information saved in FLASH, the machine displays power-on picture, servo system begins to work to check whether machine closes door to proper position and whether detect switch has been closed, if not, the door close action is performed. After detect switch of door is closed, the machine begins to perform preparations of disc reading and performs panel display at the same time of working.

Playback process: laser head picks up disc signal from disc, after servo system processing, then send to decode circuit for decoding, signal after being decoded is saved in SDRAM for the moment. When machine needs to replay signal, decode circuit calls information inside SDRAM to perform D/A conversion and then output.

User information storage: information content set by user is saved inside EEPROM, if user does not refresh or reset this information, it will be saved in IC permanently.

Audio, video output circuit: at present, MT1389 all integrates video D/A converter, MT1389HD inside integrates audio D/A converter, manufacturers select according to their own needs. Please refer to circuit principle diagram and audio circuit explanation for details

### 3.2.9 Reset circuit

1. Reset circuit is shown as in the following figure 3.2.9.1:

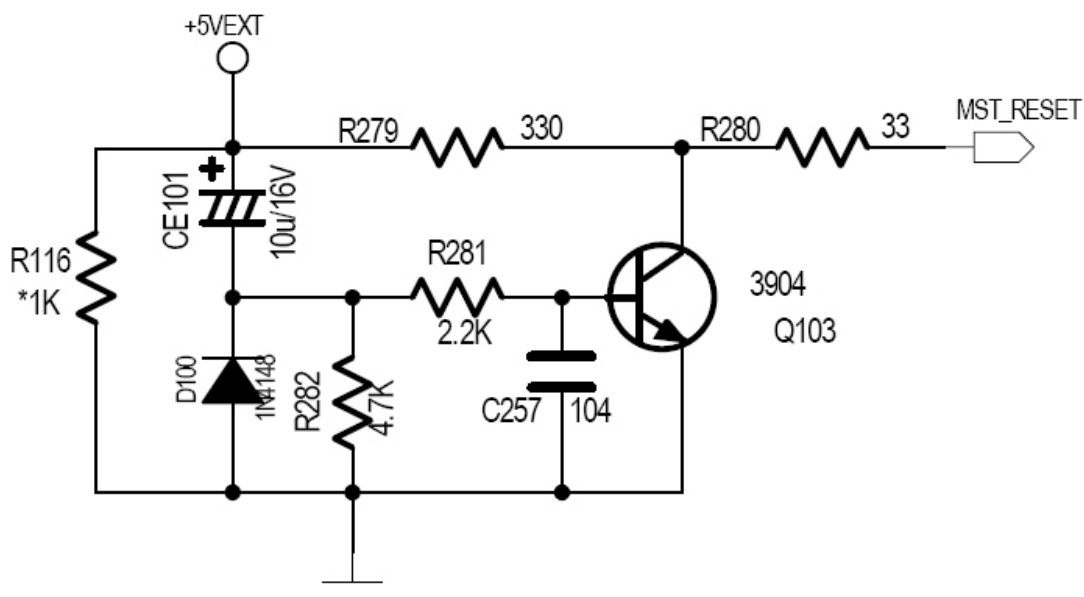

Figure 3.2.9.1 Reset circuit diagram



2. Working principle: after power on, voltage of +5VEXT increases to 5V, main chip power supply is normal. Now, voltage of CE101 to +5VEXT cannot change suddenly to make base electrode of Q103 Has current flow in, Q103 is saturation on, URST is low level. +5VEXT charges CE101 in two paths through Emitter junction of R262 and Q103 make negative pole voltage of CE101 decrease slowly. When this voltage decreases below 0.7V, Q103 cuts off, URST changes into high level, the process for URST from low to high is called effective reset signal of low level by us. After power off, voltage of +5VEXT decreases, CE101 decreases together with +5VEXT voltage, D100 performs surge discharge and clamping to CE101.

3. Key point voltage (unit: V)

Q103\_B is low level when in normal condition, at the moment of power on, it decreased to 0V from 5V gradually.

Q103\_C is high level when in normal condition, at the moment of power on, it increases to 5V from 0V.

### 3.2.10 Video circuit

1. Video signal flow chart diagram is shown as in the following figure 3.2.10.1 :

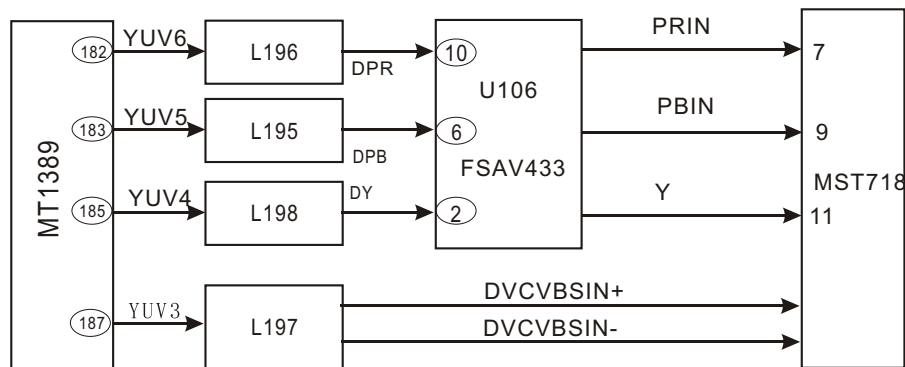

Figure 3.2.10.1 Video signal flow chart

2. Working principle: MT1389HD has built-in video D/A conversion circuit, video output has Y/Pb/Pr Y/Cb/Cr CVBS Y/C output mode, This player adopts component video/composite video mode to output to video main board of TV part MST718 and other video output mode is not used.

Shown as in the figure 3.2.10.2, capacitor C372, C208 and inductor L197 compose a low-pass filter to filter high frequency disturbance signal except useful signal; C210 is a DC capacitor, R395 is load resistor.

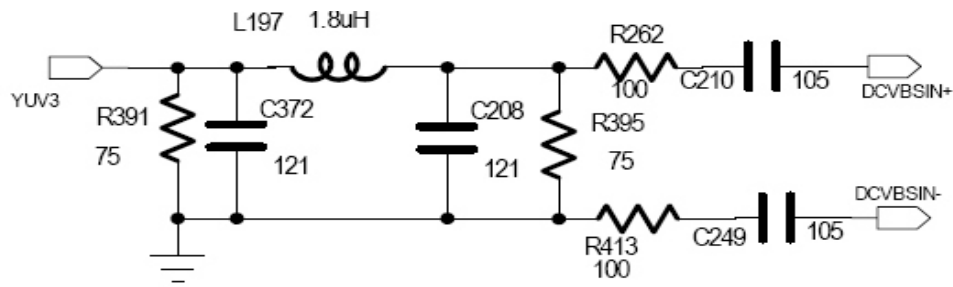

Figure 3.2.10.2 Video output circuit

### 3.2.11 Audio circuit

1. Audio signal process block diagram is shown in the figure 3.2.11.1:

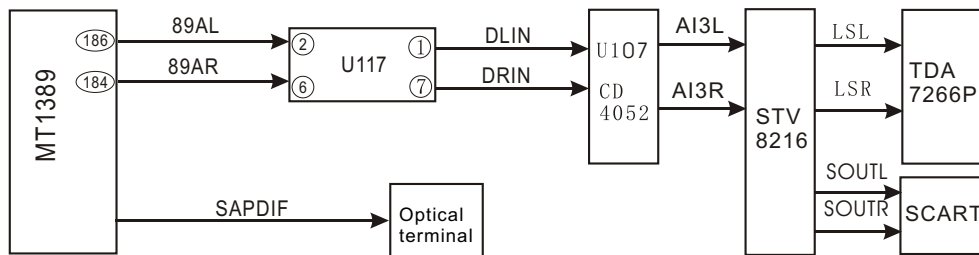

Figure 3.2.11.1 Audio signal flow chart block diagram

2. Working principle: MT1389HD has built-in audio DAC conversion circuit, analog audio signals output from decode chip directly, through audio amplifying and filtering circuit, directly output audio signals to Cd4052 and then output after sound source switch through audio switch circuit to send to stv8216 for the second selection and then output to audio amplifying circuit for amplifying and output.

### 3.2.12 USB/CARD circuit

1. USB/CARD circuit is shown as in the following figure 3.2.12.1:

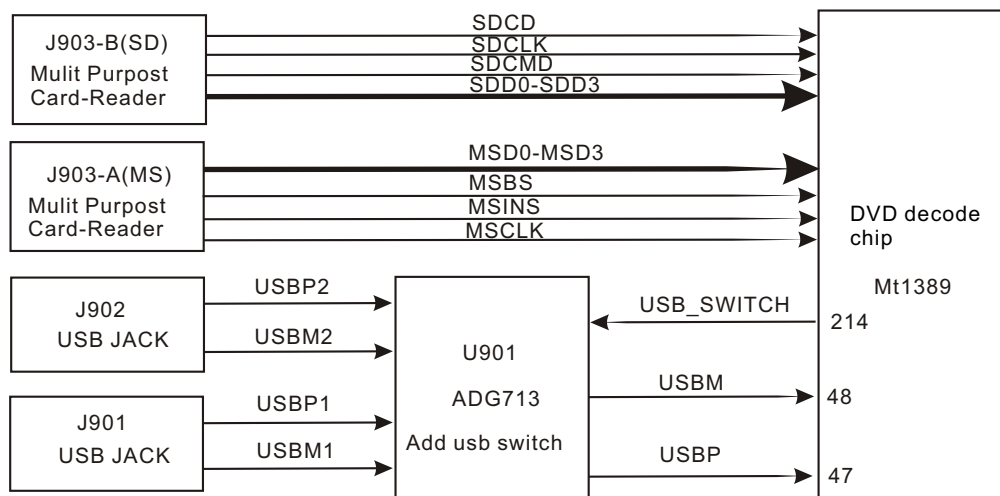

Figure 3.2.12.1 usb/card circuit diagram

2. Working principle: J903 is a 3-in-1 card holder which can read SD/MS card. When machine switches in card read state, after inserting a SD card into card holder, detect switch on card holder closes, SDCD signal becomes low level, MT1389HD begins to read SD content and then send to Mt1389 through data line SDD0-SDD3 for decoding to revert AV signals. MS card working principle is the same with that of SD card. J901/J902 is an USB port, ADG713 is an USB port switch. When machine is set in USB1, USB\_SWITCH outputs high level signal. When machine is set in USB2, USB\_SWITCH outputs a low level signal to control working state of U901 directly.

## Section Three Servicing Cases

### 3.3.1 Servicing cases

[ Example 1 ] Symptom: DVD has no sound output

Description: disc read is normal, image output is normal, DVD playing has no sound output and other external inputs are normal.

Analysis and troubleshooting: according to trouble symptom, trouble may lie in DVD board and audio jack part. Firstly check whether pin 18/19 of video main board CN112 has audio waveform and then can judge trouble lies in DVD board. Check pin 18/19 of DVD board XS103 and find that there is no audio signal waveform.

Test TC240/TC241 audio waveform and it is normal, so we judge trouble lies in U209 and peripheral elements. Firstly check power supply of U209 and find that +12V has no power supply. Test pin 2 Xs101 according to line and there is still no +12V power supply. Check pin 5 of subsidiary power amplifying board J3 and find that +12V power is normal, so we doubt flat cable from power amplifying board to main video board has trouble. Change flat cable and trouble is removed.

[ Example 2 ] Symptom: disc tray ejects out automatically

Description: after power on, load disc and disc tray ejects out automatically.

Analysis and troubleshooting: connect with video terminal, power on and load disc. After disc tray ejects in, TV screen displays "Loading" and then "Eject" after about 9 seconds. Disc ejects out, use DVD, CD, VCD disc to test and this phenomenon still exists, so we doubt pick-up has trouble because of aging and cannot read disc. After changing loader, trouble is removed. (If slot-in loader cannot read disc, disc will eject out automatically)

[ Example 3 ] Symptom: do not read USB

Description: after machine switches in USB state, it does not read USB but other functions are normal.

Analysis and troubleshooting: Use multimeter to test USB terminal and find grounding and +5V voltage are both normal. Use multimeter to test line from USB card board to DVD board and it is normal, so we doubt 1389HD has trouble. Change 1389HD and trouble is removed.

[ Example 4 ] Symptom: do not read DVD disc

Description: CD disc read is normal, after loading DVD disc, it ejects out automatically.

Analysis and troubleshooting: use multimeter to test Q302 and transmitter electrode voltage is 3.3V, which is normal; collector voltage is 2.2V and it is normal. Test inductor L312 between collector electrode and pin 23 of Xs301 and find inductor has open-circuit. After changing inductor, trouble is removed.

[ Example 5 ] Symptom: DVD has no output

Description: DVD has no output and other functions are normal.

Analysis and troubleshooting: check voltage inputted by power amplifier board and it is normal. Check 27M clock circuit and it is normal. Check U206 output circuit, and find there is only 1.4V and core voltage is abnormal (1.9V when in normal cases). After changing U206, voltage is normal and trouble is removed.

[ Example 6 ] Symptom: DVD has no image

Description: DVD disc read is normal, but no image output. After switching in TV state, image output is normal.

Analysis and troubleshooting: according to trouble symptom, trouble lies in DVD part. Test component video signal on DVD board XS103 and find brightness signal in the three-channel signals Xs103 has no output, shown in the figure 3.3.1.1, test L229 and find this inductor has no signal output. Test resistor to ground of this circuit and it is 0-ohm, so we doubt C295 has electric leakage. After changing trouble is removed.

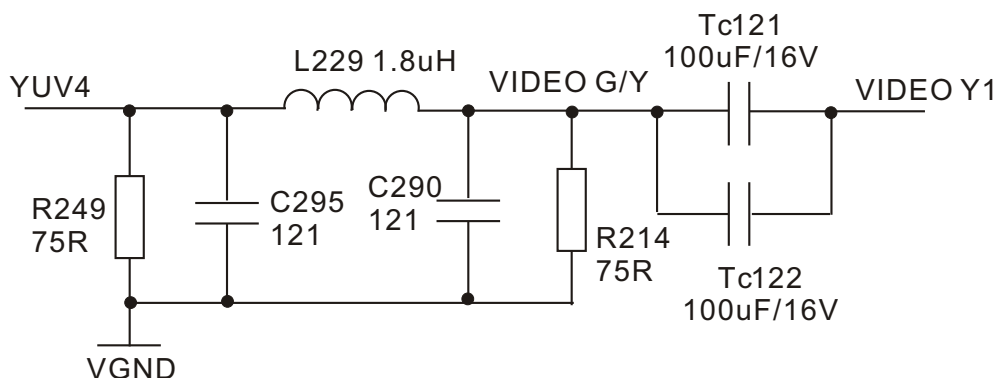
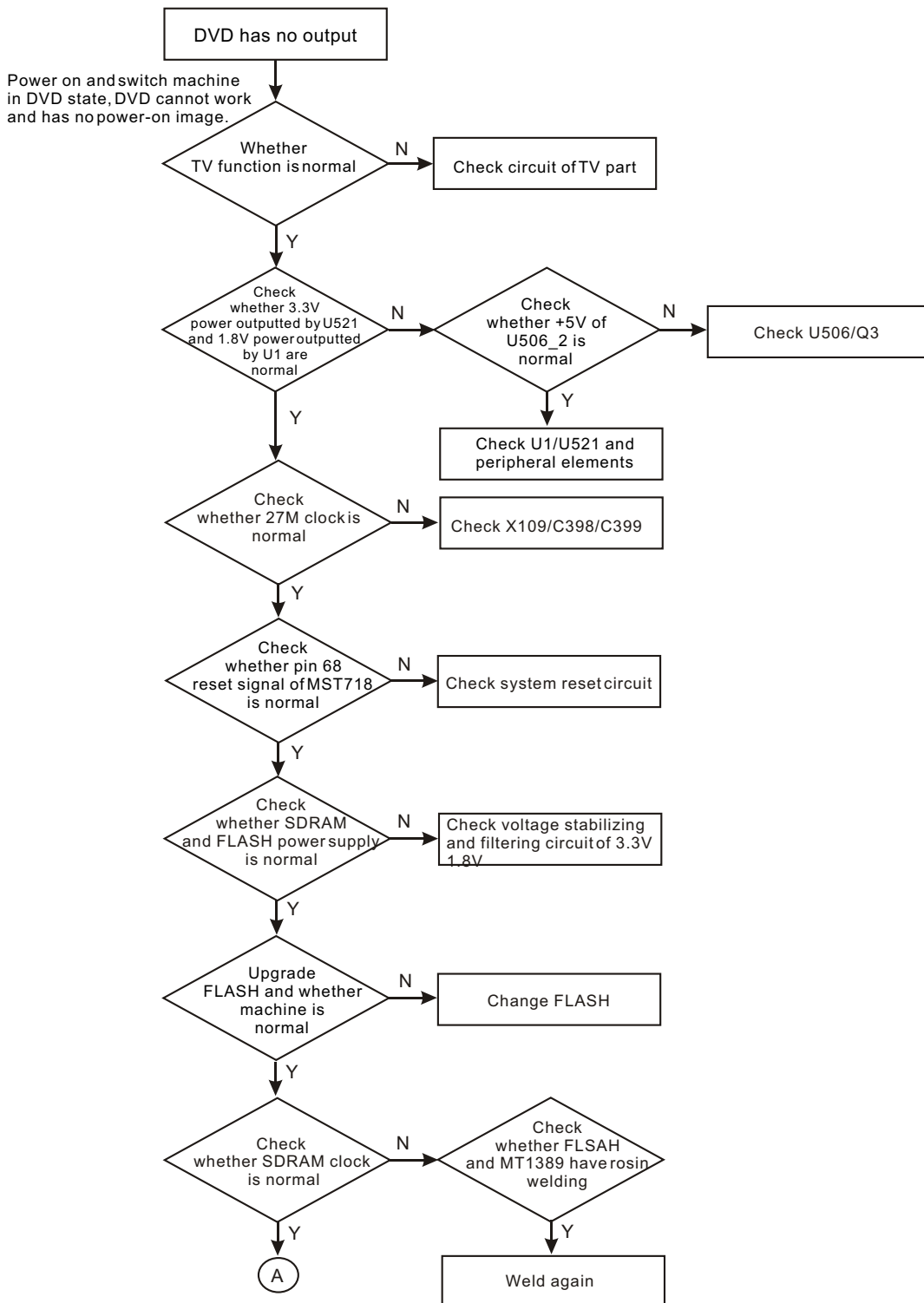

Figure 3.3.1.1 Video output circuit

### 3.3.2 Troubleshooting flow chart

1. Troubleshooting process for "DVD has no output" s shown in the figure 3.3.2.1:

Trouble description: when switching in DVD state, there is no DVD image and loader has no action of drawing in disc.



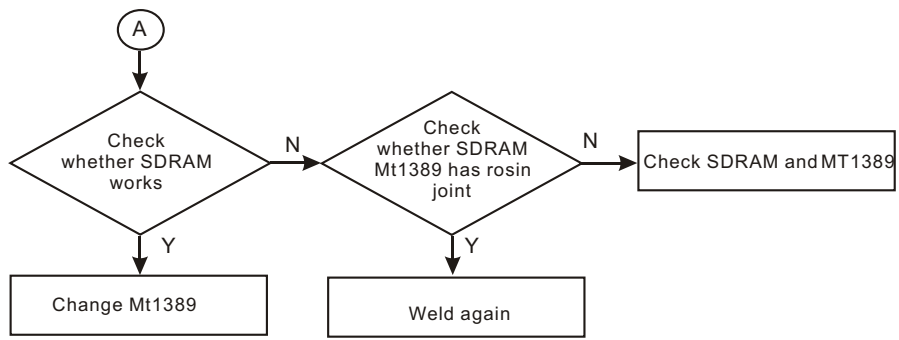
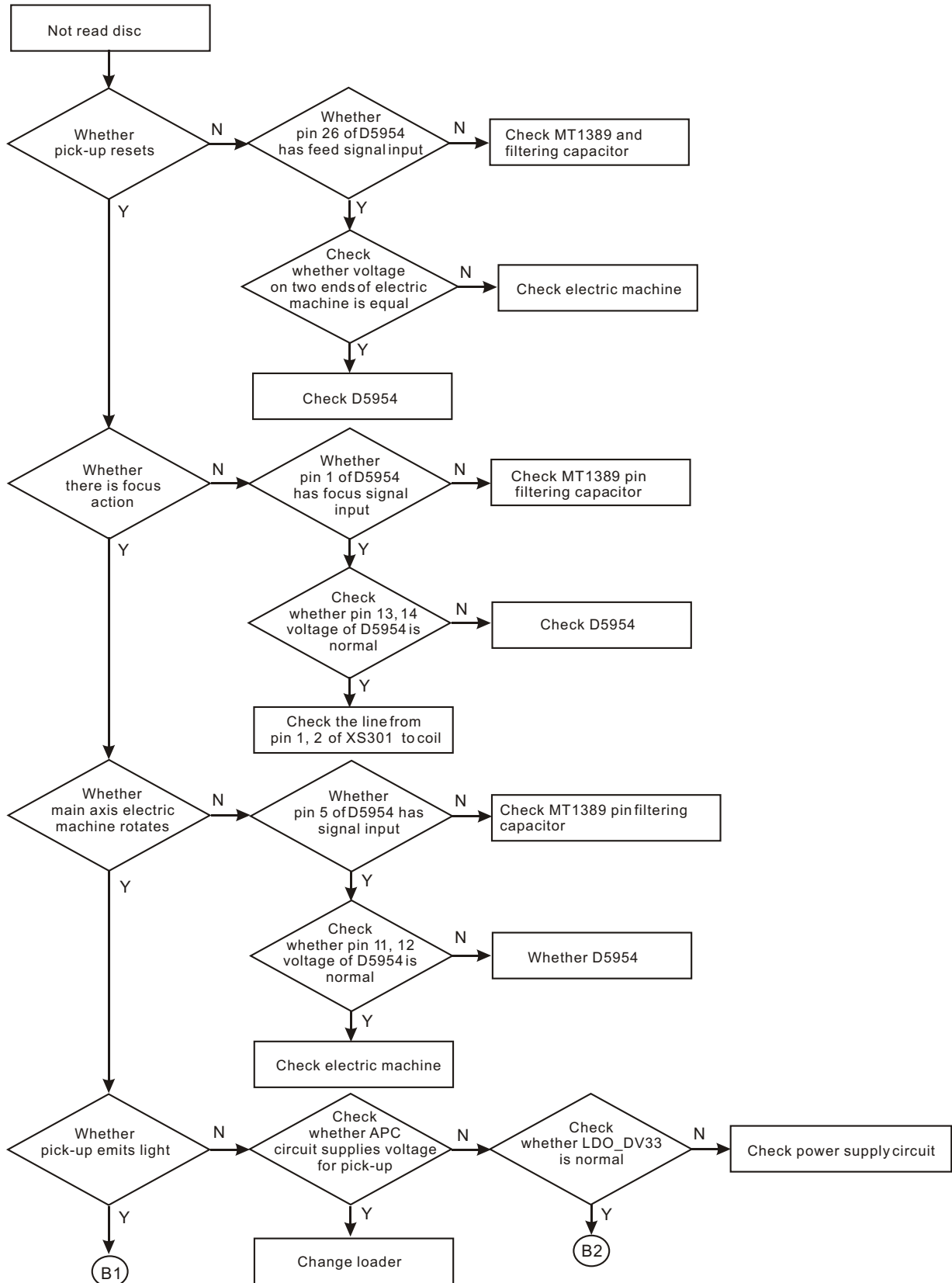

Figure 3.3.2.1 Troubleshooting flow chart for "DVD has no output"

2. Troubleshooting process for “Not read disc” is shown in the figure 3.3.2.2:

Trouble description: switch machine in DVD state, load disc and machine displays that there is no disc or cannot read disc for a long time.





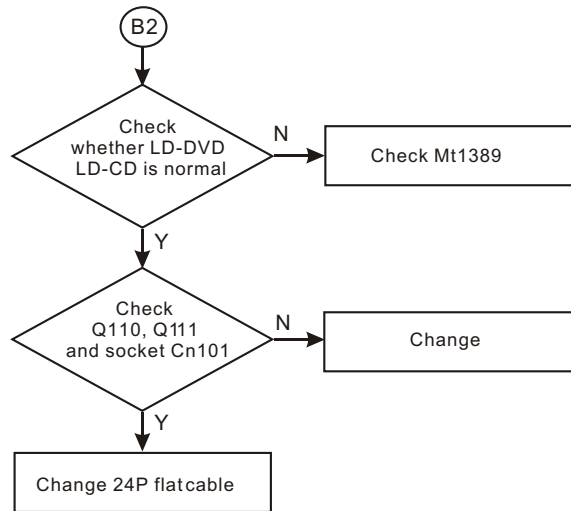
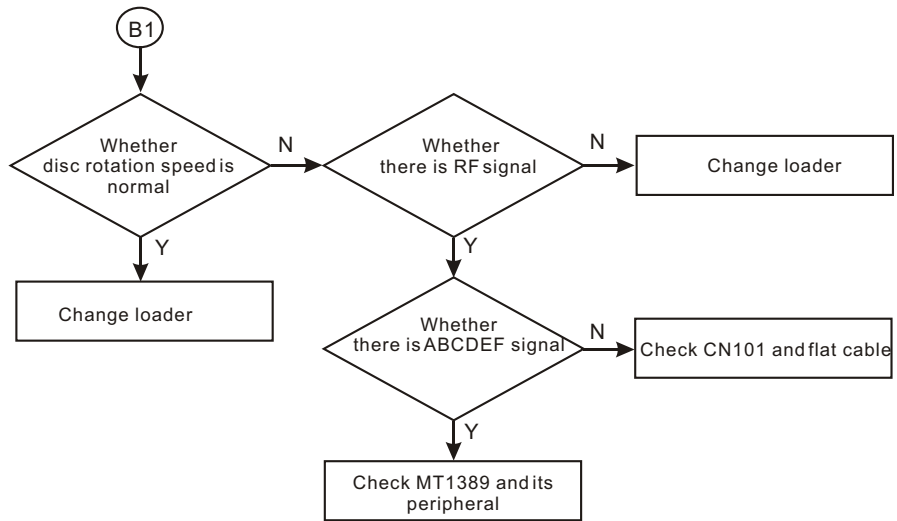

Figure 3.3.2.2 Troubleshooting flow chart for "Not read disc"

3. Troubleshooting process for “DVD has no video output” is shown in the figure 3.3.2.3:

Trouble description: machine works normally in other state; when switching in DVD state, there is sound output but no image output.

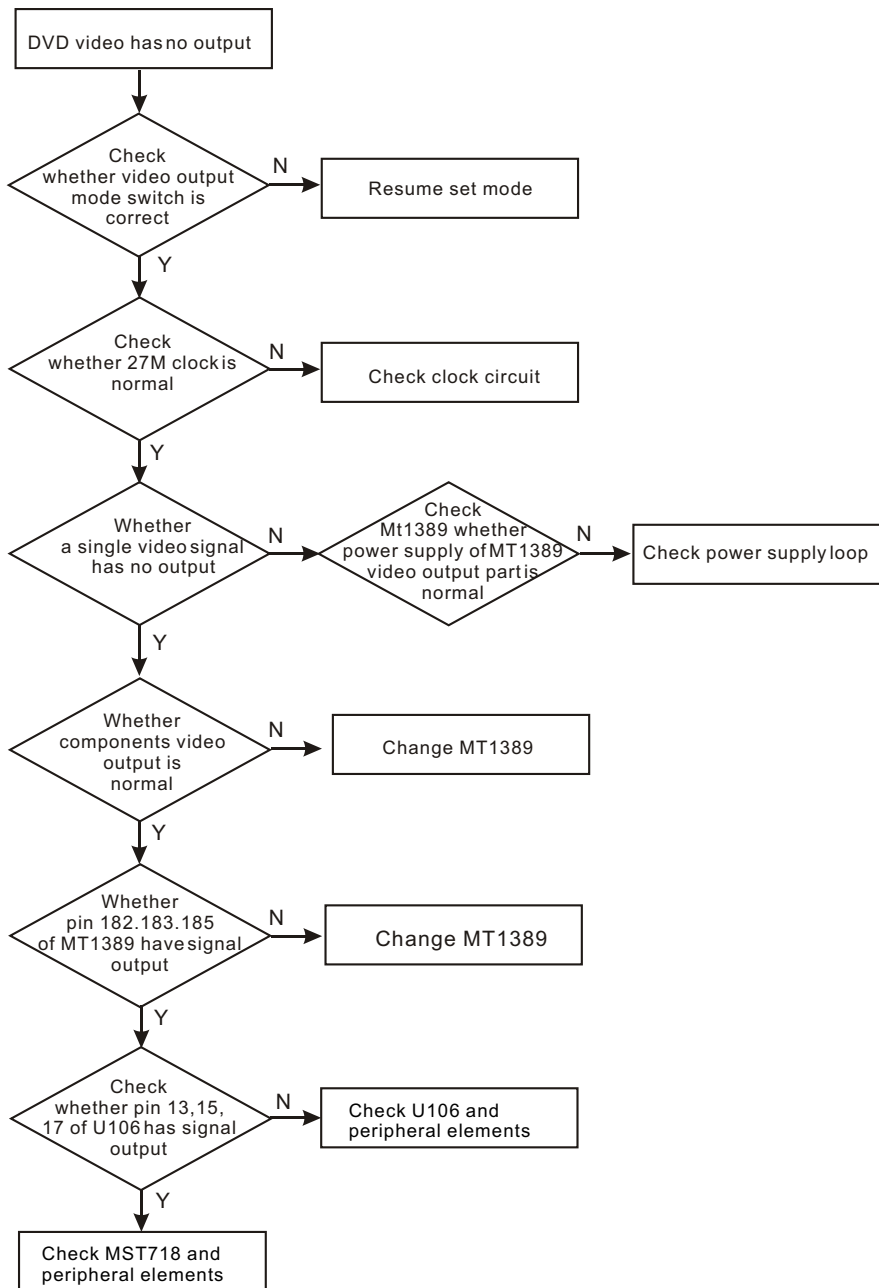

Figure 3.3.2.3 Troubleshooting flow chart for “DVD has no video output”

4. Troubleshooting process for “DVD has no sound output” is shown in the figure 3.3.2.4:

Trouble description: when machine switches in DVD state, disc read is normal, image is normal, no sound output and external sound input is normal.

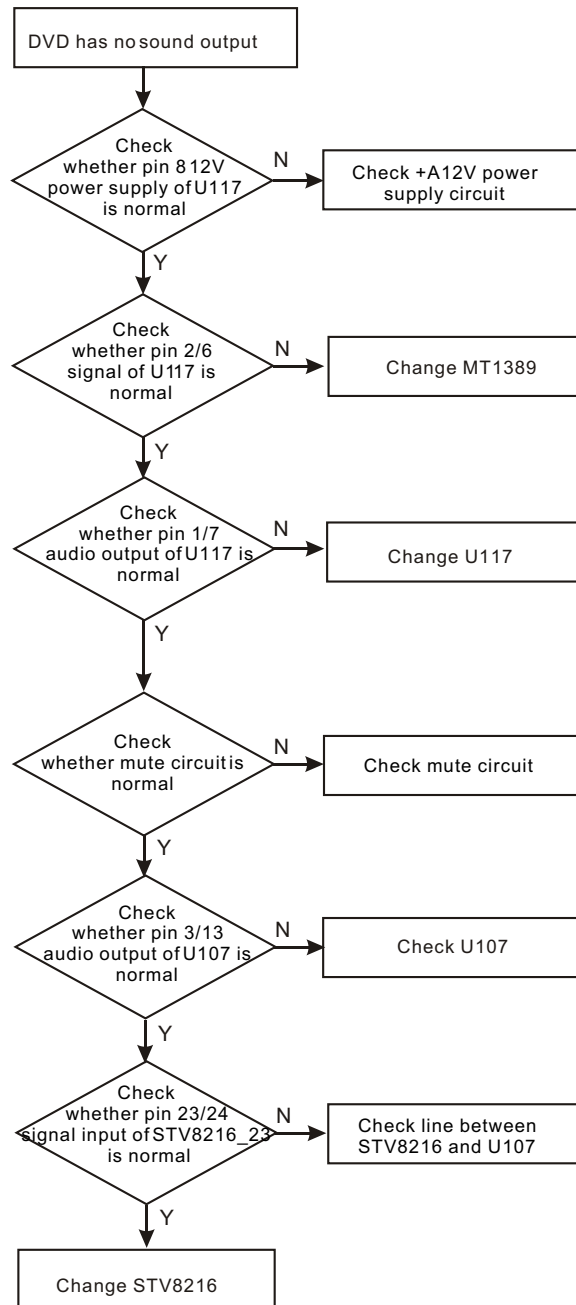
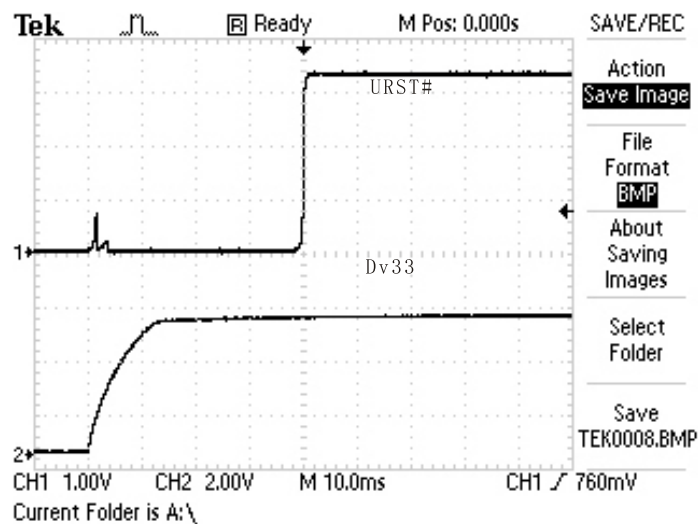

Figure 3.3.2.4 Troubleshooting flow chart for “DVD has no sound output”

## Section Four Waveform diagram

This section collects signal waveform diagram of audio, video and each unit circuit with the purpose to help servicing personnel to judge where trouble lies in accurately and quickly to improve servicing skills. For the difference of oscillograph's type, model and tuner, a certain difference may exist, so the servicing personnel are expected to pay more attention to check in daily operation.

### 1. Reset waveform diagram



### 2. Decode board

#### (1) RFO signal waveform diagram of pin 8 of XS301

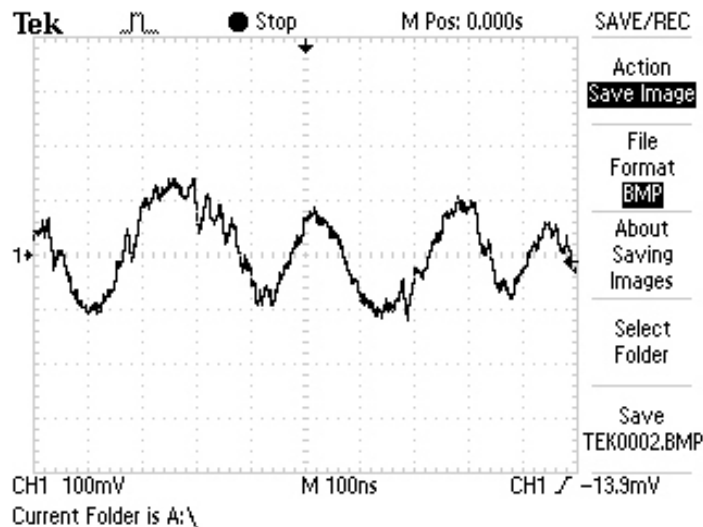

(2) A signal waveform diagram of pin 9 of Xs301(B, C, D, E, F )

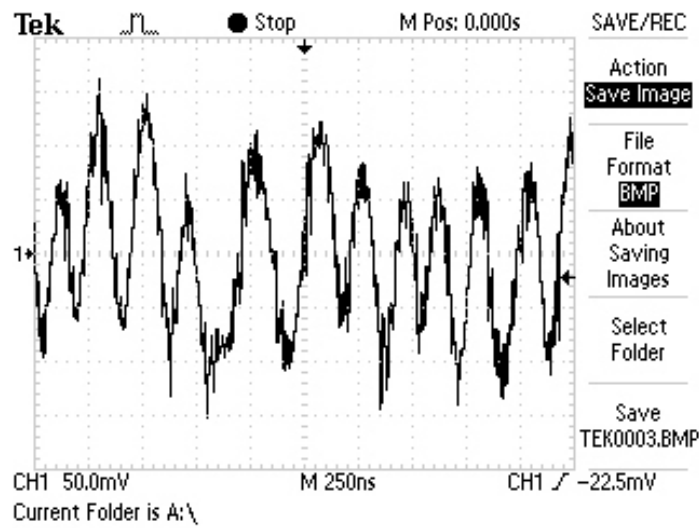

(3) DMO signal (when there is main axis rotation) waveform diagram of pin 37 of U201 (MT1389)

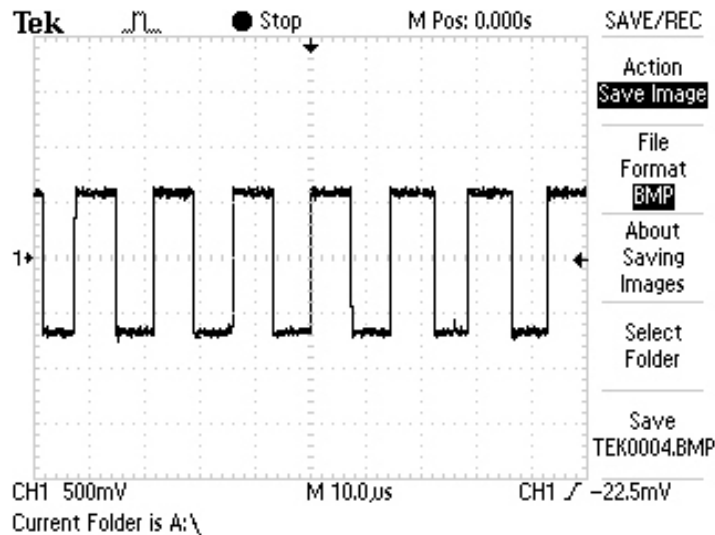

(4) FMO signal (when there is feed) waveform diagram of pin 38 of U201 (MT1389)

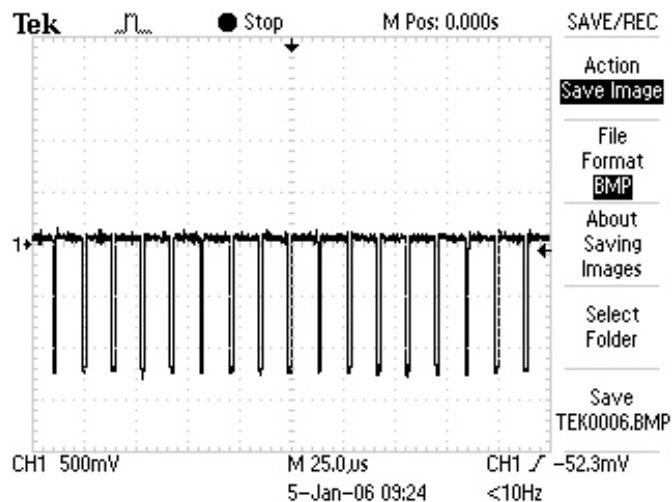

(5) TRO signal (when there is trace) waveform diagram of pin 41 of U201 (MT1389)

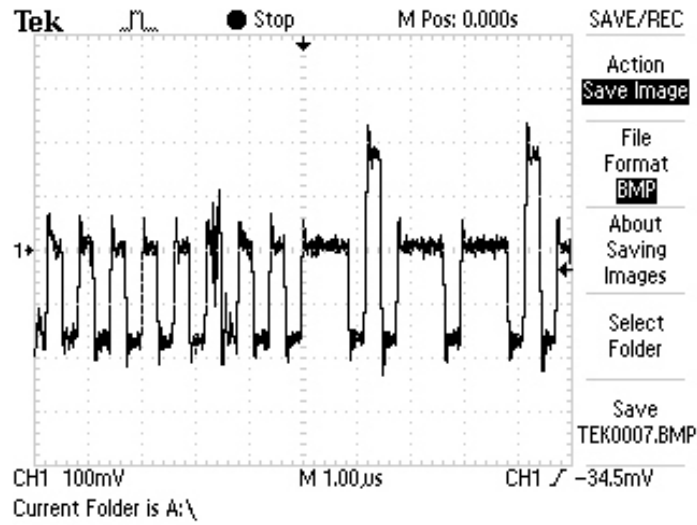

(6) FOO signal (when there is focus) waveform diagram of pin 42 of U201 (MT1389)

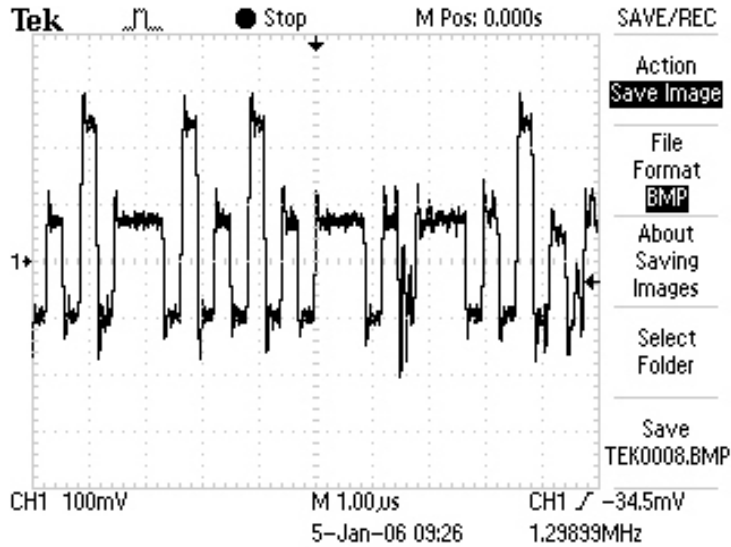

(7) Waveform diagram of pin 29 (when no disc in) of U214 (FLASH)

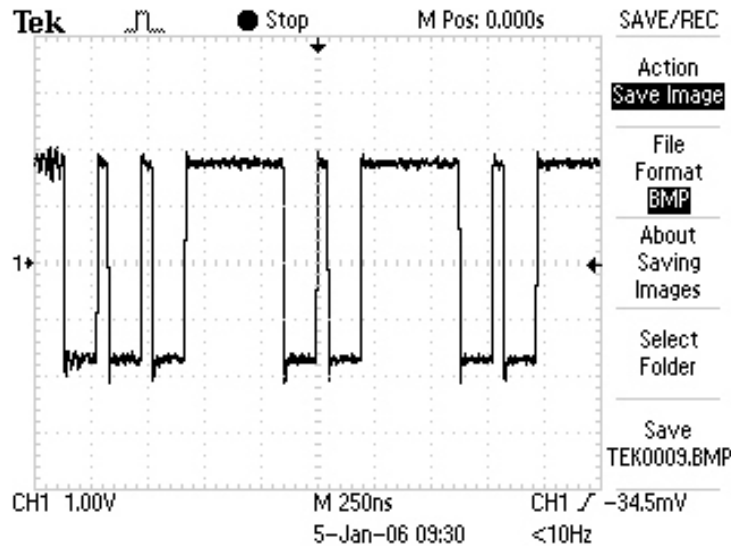

(8) Waveform diagram of pin 38 of U211 (SDRAM)

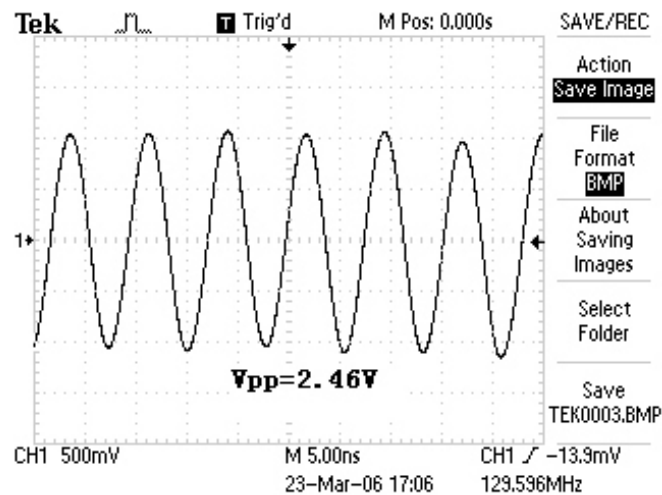

3. Video signal waveform diagram of L229

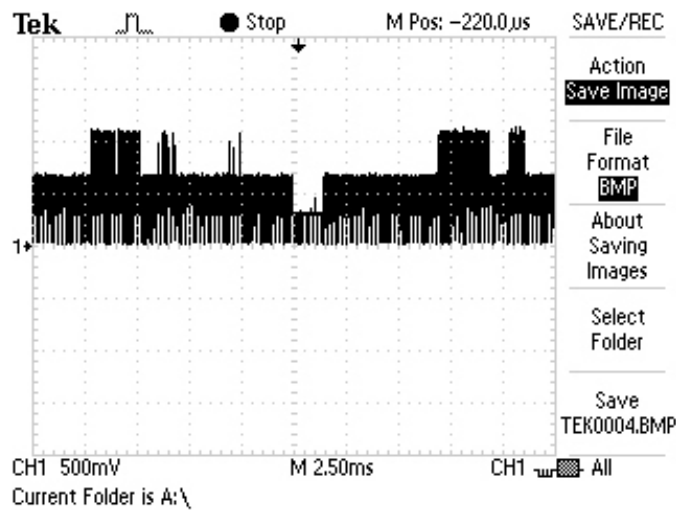

4. Waveform diagram for audio signal

(1) 1KHZ analog audio signal waveform diagram (you are recommended to use test disc, if not, the tested waveform will change at any time to affect judgment), waveform of other channels is the same except subwoofer.

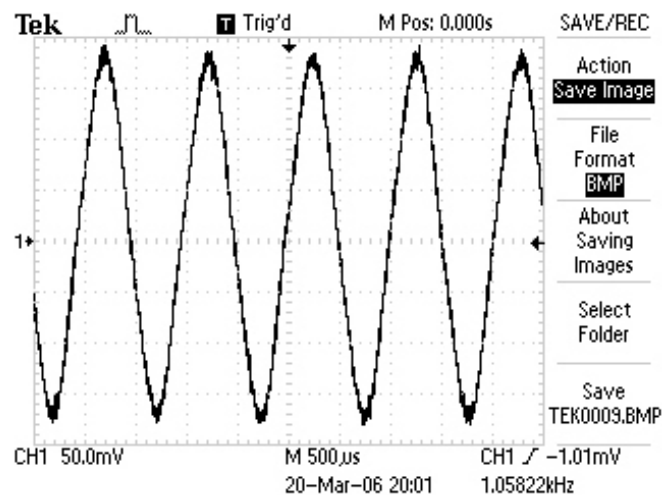

(2) SPDIF: waveform diagram for optical/coaxial digital audio signal

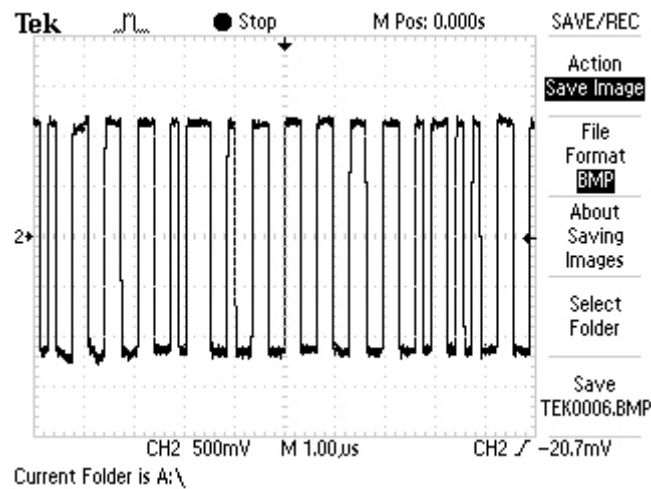

5. Waveform diagram of audio signals not being filtered and amplified (test point: audio signal amplifying input end Tc241)

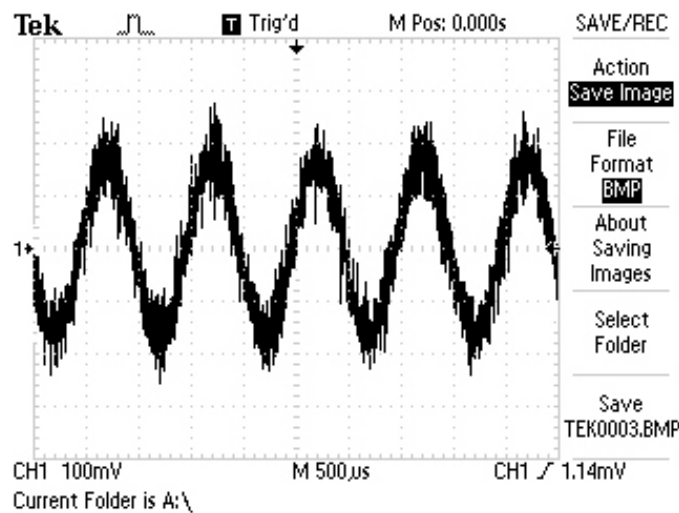

6. 27M clock signal waveform diagram.

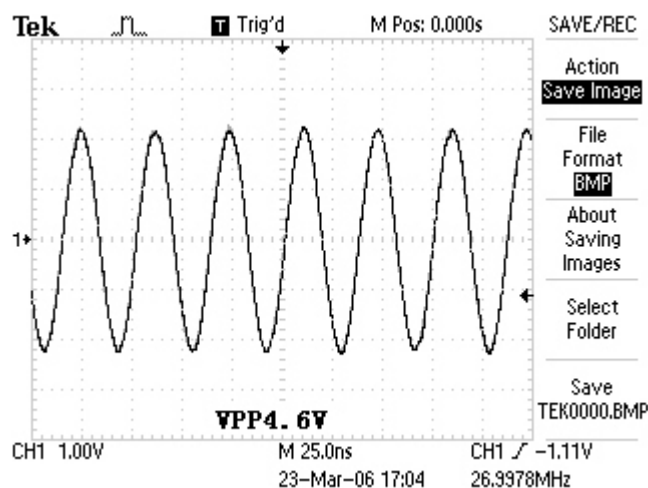



# Section Five Function Introduction to IC

## 3.5.1 Function introduction to MT1389HD

### 1. Description

MT1389HD is a cost-effective DVD system-on-chip (SOC) which incorporates advanced features like MPEG-4 video decoder, high quality TV encoder and state-of-art de-interlace processing.

Based on MediaTek's world-leading DVD player SOC architecture, the MT1389HD is the 3rd generation of the DVD player SOC. It integrates the MediaTek 2nd generation front-end analog RF amplifier and the Servo/MPEG AV decoder.

To enrich the feature of DVD player, the MT1389HD equips a simplified MPEG-4 advanced simple profile (ASP) video decoder to fully support the DivX1 Home Theater profile. It makes the MT1389-based DVD player be capable of playback MPEG-4 content which become more and more popular.

The progressive scan of the MT1389HD utilized advanced motion-adaptive de-interlace algorithm to achieve the best movie/video playback. It also supports a 3:2 pull down algorithm to give the best film effect. The 108MHz/12-bit video DAC provides users a whole new viewing experience.

### 2. General Feature lists

- (1) Integration DVD player single chip
- High performance analog RF amplifier
- Servo controller and data channel processing
- MPEG-1/MPEG-2/JPEG video
- Dolby AC-3/DTS Decoder
- Unified memory architecture
- Versatile video scaling & quality enhancement
- OSD & Sub-picture
- Built-in clock generator
- Built-in high quality TV encoder
- Built-in progressive video processor
- Audio effect post-processor
- Built-in 5.1-ch Audio DAC

(2)High Performance Analog RF Amplifier

Programmable fc

Dual automatic laser power control

Defect and blank detection

RF level signal generator

(3)Speed Performance on Servo/Channel Decoding

DVD-ROM up to 4XS

CD-ROM up to 24XS

(4)Channel Data Processor

Digital data slicer for small jitter capability

Built-in high performance data PLL for channel data demodulation

EFM/EFM+ data demodulation

Enhanced channel data frame sync protection & DVD-ROM sector sync protection

(5)Servo Control and Spindle Motor Control

Programmable frequency error gain and phase error gain of spindle PLL to control spindle motor on CLV and CAV mode

Built-in ADCs and DACs for digital servo control

Provide 2 general PWM

Tray control can be PWM output or digital output

(6)Embedded Micro controller

Built-in 8032 micro controller

Built-in internal 373 and 8-bit programmable lower address port

1024-bytes on-chip RAM

Up to 2M bytes FLASH-programming interface

Supports 5/3.3-Volt. FLASH interface

Supports power-down mode

Supports additional serial port

(7)DVD-ROM/CD-ROM Decoding Logic

High-speed ECC logic capable of correcting one error per each P-codeword or Q-codeword

Automatic sector Mode and Form detection

Automatic sector Header verification

Decoder Error Notification Interrupt that signals various decoder errors

Provide error correction acceleration

(8)Buffer Memory Controller

Supports 16Mb/32Mb/64Mb SDRAM

Supports 16-bit SDRAM data bus

Provides the self-refresh mode SDRAM

Block-based sector addressing

(9) Video Decode

Decodes MPEG1 video and MPEG2 main level, main profile video (720/480 and 720x576) Decodes

MPEG-4 Advanced Simple Profile

Support DivX 3.11/4.x/5.x Home Theater Profile

Support Nero-Digital

Smooth digest view function with I, P and B picture decoding

Baseline, extended-sequential and progressive JPEG image decoding

Support CD-G titles

(10) Video/OSD/SPU/HLI Processor

Arbitrary ratio vertical/horizontal scaling of video, from 0.25X to 256X

65535/256/16/4/2-color bitmap format OSD,

256/16 color RLC format OSD

Automatic scrolling of OSD image

(11) Audio Effect Processing

Dolby Digital (AC-3)/EX decoding

DTS/DTS-ES decoding

MPEG-1 layer 1/layer 2 audio decoding

MPEG-2 layer1/layer2 2-channel audio

High Definition Compatible Digital (HDCD)

Windows Media Audio (WMA)

Dolby ProLogic II

Concurrent multi-channel and downmix out

IEC 60958/61937 output

PCM / bit stream / mute mode

Custom IEC latency up to 2 frames

Pink noise and white noise generator

Karaoke functions

Microphone echo

Microphone tone control

Vocal mute/vocal assistant

Key shift up to +/- 8 keys

Chorus/Flanger/Harmony/Reverb

Channel equalizer

3D surround processing include virtual surround and speaker separation

(12) TV Encoder

Four 108MHz/12bit DACs

Support NTSC, PAL-BDGHINM, PAL-60  
 Support 525p, 625p progressive TV format  
 Automatically turn off unconnected channels  
 Support PC monitor (VGA)  
 Support Macrovision 7.1 L1, Macrovision 525P and 625P  
 CGMS-A/WSS  
 Closed Caption

(13)Progressive Scan Video

Automatic detect film or video source  
 3:2 pull down source detection  
 Advanced Motion adaptive de-interlace  
 Minimum external memory requirement

(14)Outline

216-pin LQFP package  
 3.3/1.8-Volt. Dual operating voltages

**3. Pin Definitions**

PIN	Main	Alt	Type	Description
<b>RF interface (26)</b>				
231	RFGND18		Ground	Analog ground
132	RFVDD 18		Power	Analog power 1.8V
252	OSP		Analog output	RF Offset cancellation capacitor connecting
253	OSN		Analog output	RF Offset cancellation capacitor connecting
254	RFGC		Analog output	RF AGC loop capacitor connecting for DVD-ROM
255	IREF		Analog input	Current reference input. It generates reference current for RF path. Connect an external 15K resistor to this pin and AVSS
256	AVDD3		Power	Analog power 3.3V
1	AGND		Ground	Analog ground
2	DVDA		Analog input	AC couple input path A
3	DVDB		Analog input	AC couple input path B
4	DVDC		Analog input	AC couple input path C
5	DVDD		Analog input	AC couple input path D
6	DVDRFIP		Analog input	AC coupled DVD RF signal input RFIP
7	DVDRFIN		Analog input	AC coupled DVD RF signal input RFIN
8	MA		Analog input	DC coupled main beam RF signal input A

9	MB		Analog input	DC coupled main beam RF signal input B
10	MC		Analog input	DC coupled main beam RF signal input C
11	MD		Analog input	DC coupled main beam RF signal input D
12	SA		Analog input	DC coupled sub-beam RF signal output A
13	SB		Analog input	DC coupled sub-beam RF signal output B
14	SC		Analog input	DC coupled sub-beam RF signal output C
15	SD		Analog input	DC coupled sub-beam RF signal output D
16	CDFON		Analog input	CD focusing error negative input
17	CDFOP		Analog input	CD focusing error positive input
18	TNI		Analog input	3 beam satellite PD signal negative input
19	TPI		Analog input	3 beam satellite PD signal positive input
<b>ALPC (4)</b>				
20	MIDI1		Analog input	Laser power monitor input
21	MIDI2		Analog input	Laser power monitor input
22	LDO2		Analog output	Laser driver output
23	LDO1		Analog output	Laser driver output
<b>ADC Power ( 2 )</b>				
244	ADCVDD3		Power	Analog 3.3V Power for ADC
245	ADCVSS		Ground	Analog ground for ADC
<b>VPLL (3)</b>				
43	VPLLVSS		Ground	Analog ground for VPLL
44	CAPPAD		Analog In/Out	VPLL External Capacitance connection
45	VPLLVDD3		Power	Analog 3.3V Power for VPLL
<b>Reference voltage (3)</b>				
28	V2REFO		Analog output	Reference voltage 2.8V
29	V20		Analog output	Reference voltage 2.0V
30	VREFO		Analog output	Reference voltage 1.4V
<b>Analog monitor output (7)</b>				
24	SVDD3		Power	Analog power 3.3V
25	CSO	RFOP	Analog output	1) Central servo 2) Positive main beam summing output
26	RFLVL	RFON	Analog output	1) RFRP low pass, or 2) Negative main beam summing output
27	SGND		Ground	Analog ground

31	FEO		Analog output	Focus error monitor output
32	TEO		Analog output	Tracking error monitor output
33	TEZISLV		Analog output	TE slicing Level
<b>Analog monitor output (6)</b>				
246	RFVDD3		Analog output	Analog Power
247	RFRPDC		Analog Input	RF ripple detect output
248	RFRPAC		Analog output	RF ripple detect input(through AC-coupling)
249	HRFZC		Analog output	High frequency RF ripple zero crossing
250	CRTPLP		Analog output	Defect level filter capacitor connecting
251	RFGND		Ground	Analog Power
<b>RF Data PLL Interface (9)</b>				
235	JITFO		Analog output	Output terminal of RF jitter meter
236	JITFN		Analog Input	Input terminal of RF jitter meter
237	PLLSS		Ground	Ground pin for data PLL and related analog circuitry
238	IDACEXLP		Analog output	Data PLL DAC Low-pass filter
239	PLLVDD3		Power	Power pin for data PLL and related analog circuitry
240	LPFON		Analog Output	Negative output of loop filter amplifier
241	LPFIP		Analog input	Positive input terminal of loop filter amplifier
242	LPFIN		Analog input	Negative input terminal of loop filter amplifier
243	LPFOP		Analog output	Positive output of loop filter amplifier
<b>Motor and Actuator Driver Interface (10)</b>				
34	OP_OUT		Analog output	Op amp output
35	OP_INN		Analog input	Op amp negative input
36	OP_INP		Analog input	Op amp positive input
37	DMO		Analog output	Disk motor control output. PWM output
38	FMO		Analog output	Feed motor control. PWM output
39	TROPENPW M		Analog output	Tray PWM output/Tray open output
40	PWMOUT1	ADIN0	Analog output	1) 1st General PWM output 2) AD input 0
41	TRO		Analog output	Tracking servo output. PDM output of tracking servo compensator
42	FOO		Analog output	Focus servo output. PDM output of focus servo compensator

50	FG (Digital pin)	ADIN1 GPIO	LVTTL3.3 Input, Schmitt input, pull up, with analog input path for ADIN1	1) Monitor hall sensor input 2) AD input 1 3) GPIO
<b>General Power/Ground (18)</b>				
55 93 142 160 174 213	DVDD18		Power	1.8V power pin for internal digital circuitry
81 178	DVSS		Ground	1.8V ground pin for internal digital circuitry
65 96 118 131 145 156 170 208	DVDD3		Power	3.3V power pin for internal digital circuitry
90 148	DVSS		Ground	3.3V ground pin for internal digital circuitry
<b>Micro Controller and Flash Interface (48)</b>				
62	HIGHA0		In/Out 4~16mA,SRPU	Microcontroller address 8
74	HIGHA1		In/Out 4~16mA,SRPU	Microcontroller address 9
73	HIGHA2		In/Out 4~16mA,SRPU	Microcontroller address 10
72	HIGHA3		In/Out 4~16mA,SRPU	Microcontroller address 11
71	HIGHA4		In/Out 4~16mA,SRPU	Microcontroller address 12
70	HIGHA5		In/Out 4~16mA,SRPU	Microcontroller address 13
69	HIGHA6		In/Out 4~16mA,SRPU	Microcontroller address 14
68	HIGHA7		In/Out 4~16mA,SRPU	Microcontroller address 15
89	AD7		In/Out 4~16mA,SRPU	Microcontroller address/data 7
86	AD6		In/Out 4~16mA,SRPU	Microcontroller address/data 6
85	AD5		In/Out 4~16mA,SRPU	Microcontroller address/data 5

84	AD4		In/Out 4~16mA,SRPU	Microcontroller address/data 4
83	AD3		In/Out 4~16mA,SRPU	Microcontroller address/data 3
82	AD2		In/Out 4~16mA,SRPU	Microcontroller address/data 2
80	AD1		In/Out 4~16mA,SRPU	Microcontroller address/data 1
79	AD0		In/Out 4~16mA,SRPU	Microcontroller address/data 0
92	IOA 0		In/Out 4~16mA,SRPU	Microcontroller address
77	IOA 1		In/Out 4~16mA,SRPU	Microcontroller address 1/ IO
56	IOA 2		In/Out 4~16mA,SRPU	Microcontroller address 2/ IO
57	IOA 3		In/Out 4~16mA,SRPU	Microcontroller address 3/ IO
58	IOA 4		In/Out 4~16mA,SRPU	Microcontroller address 4/ IO
59	IOA 5		In/Out 4~16mA,SRPU	Microcontroller address 5/ IO
60	IOA 6		In/Out 4~16mA,SRPU	Microcontroller address 6/ IO
61	IOA 7		In/Out 4~16mA,SRPU	Microcontroller address 7/ IO
67	A16		In/Out 4~16mA,SRPU	Flash address 16
91	A17		In/Out 4~16mA,SRPU	Flash address 17
63	A18		In/Out 4~16mA, SRPD,SMT	Flash address 18 /IO
64	A19		In/Out 4~16mA, SRPD,SMT	Flash address 19 /IO
75	A20	YUV0	In/Out 4~16mA, SRPD,SMT	5) Flash address 20 /IO 6) While External Flash size <= 1MB: I) Alternate digital video YUV output 0
87	A21	YUV7 GPIO	In/Out 4~16mA, SRPD,SMT	7) Flash address 21 /IO 8) While External Flash size <= 2MB: I) Digital video YUV output 7 II) GPIO
88	ALE		In/Out 4~16mA, SRPD,SMT	Microcontroller address latch enable
78	IOOE#		In/Out 4~16mA, SRPD,SMT	Flash output enable, active low / IO
66	IOWR#		In/Out 4~16mA, SRPD,SMT	Flash write enable, active low / IO
76	IOCS#		In/Out 4~16mA, SRPD,SMT	Flash chip select, active low / IO
94	UWR#		In/Out 4~16mA, SRPD,SMT	Microcontroller write strobe, active low



95	URD#		In/Out 4mA, SRPD,SMT	Microcontroller read strobe, active low
97	UP1_2		In/Out 4~16mA, SRPD,SMT	Microcontroller port 1-2
98	UP1_3		In/Out 4mA, SRPD,SMT	Microcontroller port 1-3
99	UP1_4		In/Out 4mA, SRPD,SMT	Microcontroller port 1-4
100	UP1_5		In/Out 4mA, SRPD,SMT	Microcontroller port 1-5
101	UP1_6	SCL	In/Out 4mA, SRPD,SMT	1) Microcontroller port 1-6 2) I2C clock pin
102	UP1_7	SDA	In/Out 4mA, SRPD,SMT	1) Microcontroller port 1-7 1) I2C data pin
103	UP3_0	RXD	In/Out 4mA, SRPD,SMT	1) Microcontroller port 3-0 2) 8032 RS232 RxD
104	UP3_1	TXD	In/Out 4mA, SRPD,SMT	1) Microcontroller port 3-1 2) 8032 RS232 TxD
105	UP3_4	RXD SCL	In/Out 4mA, SRPD,SMT	1) Microcontroller port 3-4 2) Hardwired RD232 RxD 3) I2C clock pin
106	UP3_5	RXD SDA	In/Out 4~16mA, SRPD,SMT	1) Microcontroller port 3-5 2) Hardwired RD232 TxD 3) I2C data pin
109	IR		Input SMT	IR control signal input
110	INT0#		In/Out 4~16mA, SRPD,SMT	Microcontroller external interrupt 0, active low
<b>Audio interface ( 28 )</b>				
204	SPMCLK	SCLK0	In/Out	1) Audio DAC master clock of SPDIF input 2) While SPDIF input is not used: I) Serial interface port 0 clock pin II) GPIO
205	SPDATA	SDIN0	In/Out	1) Audio data of SPDIF input 2) While SPDIF input is not used: I) Serial interface port 0 data-in II) GPIO

206	SPLRCK	SDO0	In/Out	1) Audio left/right channel clock of SPDIF input 2) While SPDIF input is not used: I) Serial interface port 0 data-out II) GPIO
207	SPBCK	SDCS0 ASDATA 5	In/Out	1) Audio bit clock of SPDIF input 2) While SPDIF input is not used: I) Serial interface port 0 chip select II) Audio serial data 5 part I : DSD data sub-woofer Channel or Microphone output III) GPIO
209	ALRCK		In/Out 4mA, PD,SMT	1) Audio left/right channel clock 2) Trap value in power-on reset: I) 1: use external 373 II) 0: use internal 373
210	ABCK	Fs64	In/Out 4mA, SMT	1) Audio bit clock 2) Phase de-modulation
211	ACLK		In/Out 4mA, SMT	Audio DAC master clock
197	ASDATA0		In/Out 4mA, PD,SMT	1) Audio serial data 0 (Front-Left/Front-Right) 2) DSD data left channel 3) Trap value in power-on reset: I) 1: manufactory test mode II) 0: normal operation 4) While using external channels: ) GPO_2
202	ASDATA1		In/Out 4mA, PD,SMT	2) Audio serial data 0 (Front-Left/Front-Right) 2) DSD data right channel 3) Trap value in power-on reset: I) 1: manufactory test mode II) 0: normal operation 4) While using external channels: I) GPO_2
203	ASDATA2		In/Out 4mA, PD,SMT	1) Audio serial data 1 (Left-Surround/Right-Surround) 2) DSD data left surround channel 3) Trap value in power-on reset: I) 1: manufactory test mode II) 0: normal operation 4) While using external channels: I) GPO_1

212	ASDATA3		In/Out 4mA, PD,SMT	<ul style="list-style-type: none"> <li>1) Audio serial data 2 (Center/LFE)</li> <li>2) DSD data right surround channel</li> <li>3) Trap value in power-on reset: <ul style="list-style-type: none"> <li>I) 1: manufactory test mode</li> <li>II) 0: normal operation</li> </ul> </li> <li>4) While only 2 channels output: <ul style="list-style-type: none"> <li>I) GPO_0</li> </ul> </li> </ul>
214	ASDATA4	INT1#	In/Out 4mA, PD,SMT	<ul style="list-style-type: none"> <li>1) Audio serial data 3 (Center-back/ Center-left-back/Center-right-back, in 6.1 or 7.1 mode)</li> <li>2) DSD data center channel</li> <li>18) While only 2 channels output: <ul style="list-style-type: none"> <li>I) Digital video YUV output 6</li> <li>II) GPIO</li> </ul> </li> </ul>
215	MC_DATA	INT2#	In/Out 2mA, PD,SMT	<ul style="list-style-type: none"> <li>1) Microphone serial input</li> <li>2) While not support Microphone: <ul style="list-style-type: none"> <li>I) Microcontroller external interrupt 2</li> <li>II) GPIO</li> </ul> </li> </ul>
216	SPDIF		Output 4~16mA, SR: ON/OFF	S/PDIF output
217	APLLVDD3		Power	3.3V Power pin for audio clock circuitry
218	APLLCAP		Analog In/Out	APLL External Capacitance connection
219	APLLVSS		Ground	Ground pin for audio clock circuitry
220	ADACVSS2		Ground	Ground pin for AUDIO DAC circuitry
221	ADACVSS1		Ground	Ground pin for AUDIO DAC circuitry
222	ARF		Output	<ul style="list-style-type: none"> <li>1) AUDIO DAC Sub-woofer channel output</li> <li>2) While internal AUDIO DAC not used: GPIO</li> </ul>
223	ARS	GPIO	Output	<ul style="list-style-type: none"> <li>1) AUDIO DAC Right Surround channel output</li> <li>2) While internal AUDIO DAC not used: <ul style="list-style-type: none"> <li>a. SDATA3</li> <li>b. GPIO</li> </ul> </li> </ul>
224	AR	GPIO	Output	<ul style="list-style-type: none"> <li>1) AUDIO DAC Right channel output</li> <li>2) While internal AUDIO DAC not used: <ul style="list-style-type: none"> <li>a. SDATA1</li> <li>b. GPIO</li> </ul> </li> </ul>
225	AVCM		Analog	AUDIO DAC reference voltage

226	AL	GPIO	Output	1) AUDIO DAC Left Surround channel output 2) While internal AUDIO DAC not used: a. SDATA2 b. GPIO
227	ALS	GPIO	Output	1) AUDIO DAC Left Surround channel output 2) While internal AUDIO DAC not used: a. SDATA0 b. GPIO
228	ALF	GPIO	Output	1) AUDIO DAC Center channel output 2) While internal AUDIO DAC not used: GPIO
229	ADACVDD1		Power	3.3V power pin for AUDIO DAC circuitry
230	ADACVDD2		Power	3.3V power pin for AUDIO DAC circuitry
<b>Video Interface ( 18 )</b>				
196	DACVDDC		Power	3.3V power pin for VIDEO DAC circuitry
195	VREF		Analog	Bandgap reference voltage
194	FS		Analog	Full scale adjustment
193	YUV0	CIN	Output 4MA, SR	1) Video data output bit 0 2) Compensation capacitor
192	DACVSSC		Ground	Ground pin for VIDEO DAC circuitry
191	YUV1	Y	Output 4MA, SR	1) Video data output bit 1 2) Analog Y output
190	DACVddb		Power	3.3V power pin for VIDEO DAC circuitry
189	YUV2	C	Output 4MA, SR	1) Video data output bit 2 2) Analog chroma output
188	DACVSSB		Ground	Ground pin for VIDEO DAC circuitry
187	YUV3	CVBS	Output 4MA, SR	1) Video data output bit 3 2) Analog composite output
186	DACVDDA		Power	3.3V power pin for VIDEO DAC circuitry
185	YUV4	Y/G	Output 4MA, SR	1) Video data output bit 4 2) Green or Y
184	DACVSSA		Ground	Ground pin for VIDEO DAC circuitry
183	YUV5	B/Cb/Pb	Output 4MA, SR	1) Video data output bit 5 2) Blue or CB
182	YUV6	R/Cr/Pr	Output 4MA, SR	1) Video data output bit 6 2) Red or CR

181	VSYN	V_ADIN1	Output 4mA, SR	1) Vertical sync input/output 2) While no External TV-encoder: I) Vertical sync for video-input II) Version AD input port 1 III) GPIO
180	YUV7	INT3# ASDATA 5	Output 4mA, SR	1) Video data output bit 7 2) While no External TV-encoder: I) Microcontroller external interrupt 3 II) Audio serial data 5 part II : DSD data sub-woofer channel or Microphone output III) GPIO
179	HSYN	INT4# V_ADIN2	Output 4mA, SR	1) Horizontal sync input/output 2) While no External TV-encoder: I) Horizontal sync for video-input II) Version AD input port 2 III) GPIO IV) Microcontroller external interrupt 4
<b>Video Interface (12)</b>				
160	DACVDDC		Power	3.3V power pin for video DAC circuitry
161	VREF		Analog	Bandgap reference voltage
162	FS		Analog	Full scale adjustment
163	DACVSSC		Ground	Ground pin for video DAC circuitry
164	CVBS		In/Out 4mA, SR	Analog composite output
165	DACVDDB		Power	3.3V power pin for video DAC circuitry
166	DACVSSB		Ground	Ground pin for video DAC circuitry
167	DACVDDA		Power	3.3V power pin for video DAC circuitry
168	Y/G		In/Out 4mA, SR	Green, Y, SY, or CVBS
169	DACVSSA		Ground	Ground pin for video DAC circuitry
170	B/CB/PB		In/Out 4mA, SR	Blue, CB/PB, or SC
171	R/CR/PR		In/Out 4mA, SR	Red, CR/PR, CVBS, or SY
<b>MISC (12)</b>				

108	PRST#		In/Out PD,SMT	Power on reset input, active low
107	ICE		In/Out PD,SMT	Microcontroller ICE mode enable
233	XTALO		Output	27MHz crystal output
234	XTALI		Input	27MHz crystal input
46	USB_VSS		USB Ground	USB ground pin
47	USBP		Analog In/Out	USB port DPLUS analog pin
48	USBM		Analog In/Out	USB port DMINUS analog pin
49	USB_VDD3		Analog In/Out	USB Power pin 3.3V
201	GPIO3		In/Out Pull-Down	GPIO
200	GPIO4		In/Out Pull-Down	GPIO
199	RCLKB	GPIO5	In/Out Pull-Down	GPIO
198	RVREF	GPIO6	In/Out Pull-Down	GPIO
<b>Dram Interface (58) (Sorted by position)</b>				
176	C_0	IO_0(RD1 6)	In/Out Non-pull	1) Digital Video output C bit 0 2) GPIO
175	C_1	IO_1(RD1 7)	In/Out Non-pull	1) Digital Video output C bit 1 2) GPIO
173	C_2	IO_2(RD1 8)	In/Out Non-pull	1) Digital Video output C bit 2 2) GPIO
172	C_3	IO_3(RD1 9)	In/Out Non-pull	1) Digital Video output C bit 3 2) GPIO
171	C_4	IO_4(RD2 0)	In/Out Non-pull	1) Digital Video output C bit 4 2) GPIO
169	C_5	IO_5(RD2 1)	In/Out Non-pull	1) Digital Video output C bit 5 2) GPIO
168	C_6	IO_6(RD2 2)	In/Out Non-pull	1) Digital Video output C bit 6 2) GPIO
167	C_7	IO_7(RD2 3)	In/Out Non-pull	1) Digital Video output C bit 7 2) GPIO
177	IO_17	(DQM2)	In/Out Pull- Up	GPIO
166	YUVCLK	IO_8(DQ M3)	In/Out Pull- Up	1) Digital Video output Clock 2) GPIO
165	Y_0	IO_9(RD2 4)	In/Out Non-pull	1) Digital Video output Y bit 0 2) GPIO

164	Y_1	IO_10(RD 25)	In/Out Non-pull	1) Digital Video output Y bit 1 2) GPIO
163	Y_2	IO_11(RD 26)	In/Out Non-pull	1) Digital Video output Y bit 2 2) GPIO
162	Y_3	IO_12(RD 27)	In/Out Non-pull	1) Digital Video output Y bit 3 2) GPIO
161	Y_4	IO_13(RD 28)	In/Out Non-pull	1) Digital Video output Y bit 4 2) GPIO
159	Y_5	IO_14(RD 29)	In/Out Non-pull	1) Digital Video output Y bit 5 2) GPIO
158	Y_6	IO_15(RD 30)	In/Out Non-pull	1) Digital Video output Y bit 6 2) GPIO
157	Y_7	IO_16(RD 31)	In/Out Non-pull	1) Digital Video output Y bit 7 2) GPIO
155	RA4		In/Out	DRAM address 4
154	RA5		In/Out	DRAM address 5
153	RA6		In/Out	DRAM address 6
152	RA7		In/Out	DRAM address 7
151	RA8		In/Out	DRAM address 8
150	RA9		In/Out	DRAM address 9
149	RA11		In/Out	DRAM address bit 11
147	CKE		In/Out Pull-Down	DRAM clock enable
146	RCLK		In/Out	Dram clock
144	RA3		In/Out	DRAM address 3
143	RA2		In/Out	DRAM address 2
141	RA1		In/Out	DRAM address 1
140	RA0		In/Out	DRAM address 0
139	RA10		In/Out	DRAM address 10
138	BA1		In/Out	DRAM bank address 1
137	BA0		In/Out	DRAM bank address 0
136	RCS#		output	DRAM chip select, active low
135	RAS#		output	DRAM row address strobe, active low
134	CAS#		output	DRAM column address strobe, active low
133	RWE#		output	DRAM Write enable, active low

132	DQM1		In/Out	Data mask 1
130	IO_18	(DQS1)	In/Out Non-pull	GPIO
129	RD8		In/Out	DRAM data 8
128	RD9		In/Out	DRAM data 9
127	RD10		In/Out	DRAM data 10
126	RD11		In/Out	DRAM data 11
125	RD12		In/Out	DRAM data 12
124	RD13		In/Out	DRAM data 13
123	RD14		In/Out	DRAM data 14
125	RD15		In/Out	DRAM data 15
121	RD0		In/Out	DRAM data 0
120	RD1		In/Out	DRAM data 1
119	RD2		In/Out	DRAM data 2
117	RD3		In/Out	DRAM data 3
116	RD4		In/Out	DRAM data 4
115	RD5		In/Out	DRAM data 5
114	RD6		In/Out	DRAM data 6
113	RD7		In/Out	DRAM data 7
112	IO_19	(DQS0)	In/Out	GPIO
111	DQM0		In/Out Non-pull	Data mask 0
<b>JTAG Interface( 4 )</b>				
51	TDI	V_ADIN4	In/Out Non-pull	1) Serial interface port 3 data-out 2) Version AD input port 4 3) GPIO
52	TMS	V_ADIN5	In/Out Non-pull	1) Serial interface port 3 data-out 2) Version AD input port 5 3) GPIO
53	TCK	V_ADIN6	In/Out Non-pull	1) Serial interface port 3 data-out 2) Version AD input port 6 3) GPIO
54	TDO	V_ADIN7	In/Out Non-pull	1) Serial interface port 3 data-out 2) Version AD input port 7 3) GPIO



### 3.5.2 Function introduction to FLASH(U302)

FLASH 16Mbit memorizer, FLASH function pin are shown as follows:

Pin	Name	Function	Voltage (when no disc)	Data direction
1-9, 16-25, 48	AO-A19	20 bit address bus		I
11	WE	Write enable signal, low level is effective	3.23V	I
12	RESET	Reset, low level is effective	3.23V	I
10, 13, 14	NC	Blank pin		
15	RY/BY	Ready/system busy	3.23V	O
26	CE	Chip enable, low level effective	0V	I
27、 46	VSS	Ground		
28	OE	Output enable signal , low level is effective	0V	I
29-3, 6, 38-44	DQ0-DQ14	15 bit data bus		O
37	VCC	5V power supply	+5V	
45	DQ15/A-1	Take word extend mode as data line, and bit extend mode as address line		I/O
47	BYTE	Select 8-bit or 16-bit output mode. High level is 16-bit output and low level is 8-bit output		I

### 3.5.3 Function introduction to D5954

D5954 (U118) is a servo drive IC with built-in 4-channel drive circuit. Digital focus, trace, feed and main axis drive signal outputted by MT1389 is sent to D5954 for amplifying through RC integration circuit. The focus, trace, feed and main axis drive signal being amplified by D5954 is sent to loader to fulfil the corresponding servo work. The introduction to function pin is shown as the following table:

SN	Name	Function	Voltage when no disc (V)	DVD disc voltage (V)	CD disc voltage (V)
1	VINFC	Focus control signal input	1.41	1.4	1.45
2	CF1	External feedback loop	2.3	2.54	2.43
3	CF2	External feedback loop	2.01	2.56	2.43
4	VINSL+	Forward control input, connected to reference	1.41	1.42	1.42
5	VINSL-	Main axis control signal input	1.4	1.42	1.42
6	VOSL	External feedback resistor	1.4	1.17	1.21
7	VINFFC	Focus feedback signal input	1.92	2.59	2.36
8	VCC	5V power supply	5.38	5.04	5.01

9	PVCC1	5V power supply	5.38	5.04	5.03
10	PGND	Ground	0.01	0.01	0.01
11	VOSL-	Main axis drive reverse voltage output	1.87	3.71	3.54
12	VO2+	Main axis drive forward direction voltage output	1.87	1.24	1.4
13	VOFC-	Focus drive reverse voltage output	3.3	2.6	2.33
14	VOFC+	Focus drive forward voltage output	3.3	2.46	2.68
15	VOTK+	Trace drive forward direction voltage output	3.39	2.56	2.51
16	VOTK-	Trace drive reverse voltage output	3.52	2.48	2.51
17	VOLD+	Feed drive forward direction voltage output	0.93	2.56	2.5
18	VOLD-	Feed drive reverse voltage output	0.93	2.59	2.62
19	PGND	Ground	0.01	0.01	0.01
20	VINFTK	Trace feedback signal input	3.73	2.5	2.53
21	PVCC2	5V power supply	5.38	5.08	5.07
22	PREGND	Ground	0	0.01	0.01
23	VINLD	Feed control signal input	1.4	1.41	1.4
24	CTK2	External feedback loop	2.41	2.52	2.53
25	CTK1	External feedback loop	2.51	2.52	2.53
26	VINTK	Trace control signal input	1.42	1.42	1.41
27	BIAS	1.4V reference voltage input	1.41	1.42	1.42
28	STBY	Enable control signal	0	3.18	3.19

Note: pin 28 is enable restrain pin, and U302 (D5954) is high level when starting up, low level when not starting up, and pin 4 is 1.4V reference voltage.

### 3.5.4 Function introduction to 4558/4580(U117)

4558/4580 includes two integrated operational amplifiers inside, and pin function is shown as the following table:

Pin	Function	Signal flow	Pin	Function	Signal flow
1	Output of operational amplifier A	O	5	Output of operational amplifier B	O
2	Cathode input of port operational amplifier A	I	6	Cathode input of port operational amplifier B	I
3	Anode input port of operational amplifier A	I	7	Anode input of port operational amplifier B	I
4	minus 9V voltage input	I	8	(+) 9V voltage input	I

### 3.5.5 Function introduction to 24CC02A SOP (U303)

1. IS24C02 is a writable and programmable read-only memorizer, with its casing and pin function shown in the following figure 3.5.5.1:

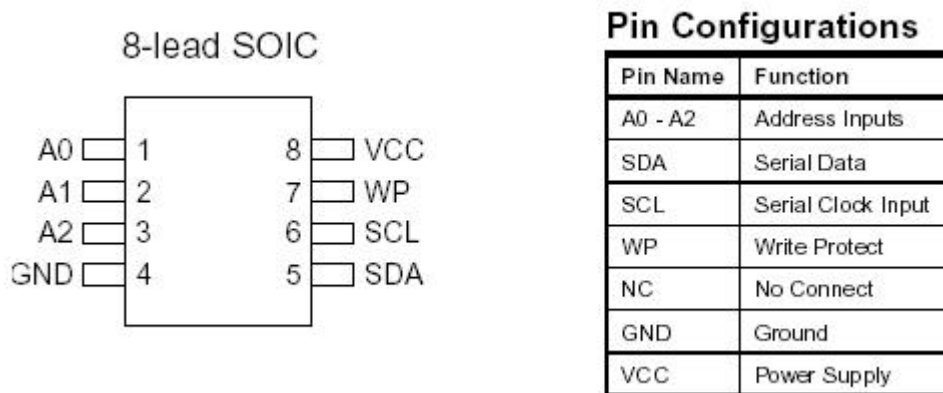

Figure 3.5.5.1 Casing and pin function explanation

2. The function of 24LLC02 is to keep some setup status of machine, such as system information of sound and language selection, not losing after power on and still keeping the information set last time when power on the next time. The circuit schematic diagram is shown as the figure3.5.5.2:

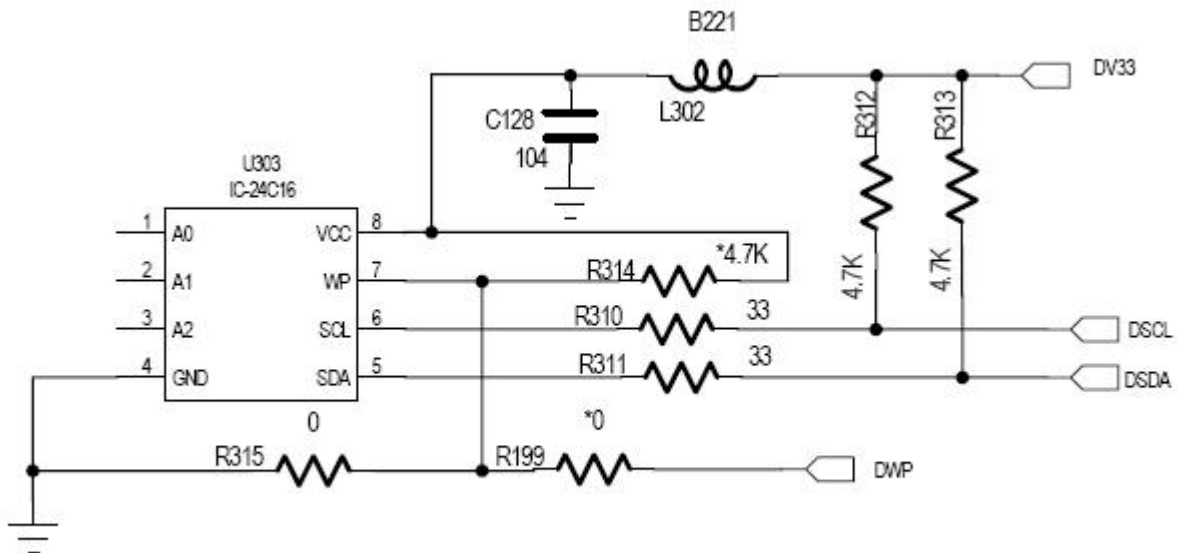

Figure 3.5.5.2 Circuit schematic diagram

# Chapter Four

## Disassembly and Assembly Process

In order to know structure of TV set LT2002S easily, directly and quickly, pictures are adopted here to present each link of assembly and disassembly process of the player to avoid operating blindly to damage elements. Structure design of this TV set is reasonable, so please avoid striking with hard objects in actual operation to ensure each parts is not damaged.



1. Place the machine on tableboard flatly. Pay attention to underlay a soft sponge spacer in displayscreen position to avoid scratching screen.



2. Use electric screwdriver to take down the screw fixed between rear casing and panel of machine and do not scratch the rear casing.



3. Place the machine on tableboard flatly and then use hand to separate the bottom right corner of machine.

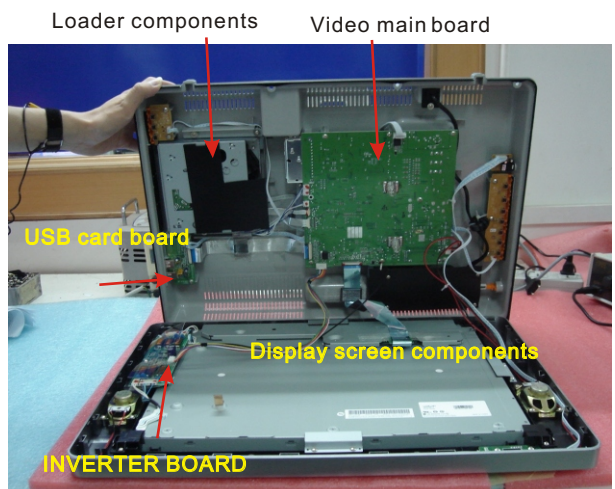

4. Separate the front casing from rear casing of machine and the internal structure is shown in the picture.

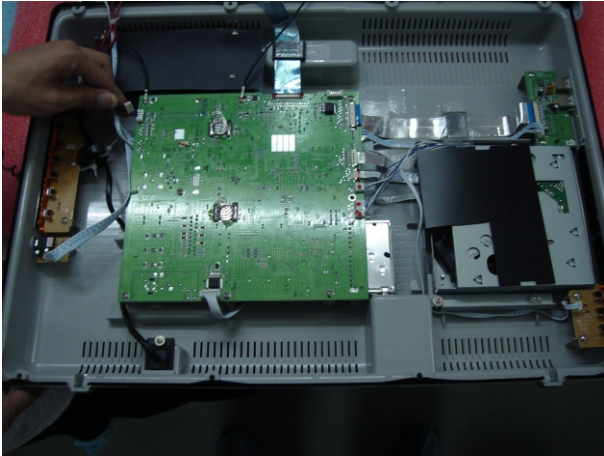

7. Remove video main board: unplug flat cable on video main board firstly.

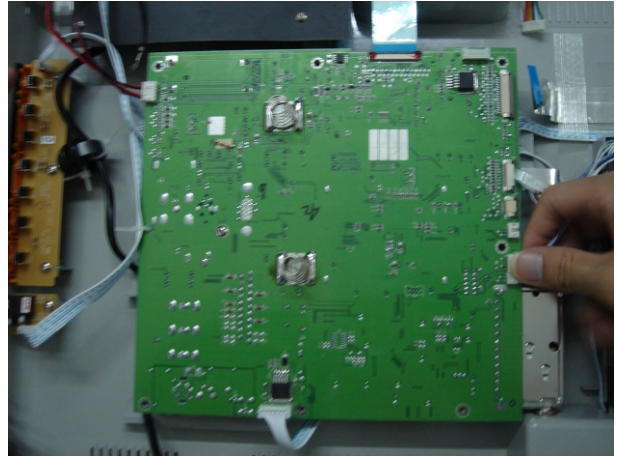

8. When removing flat cable cord, red glue on socket should be removed. After removing flat cable, remove the screw that fixes video main board.



9. Remove the two screws fixed in rear casing.

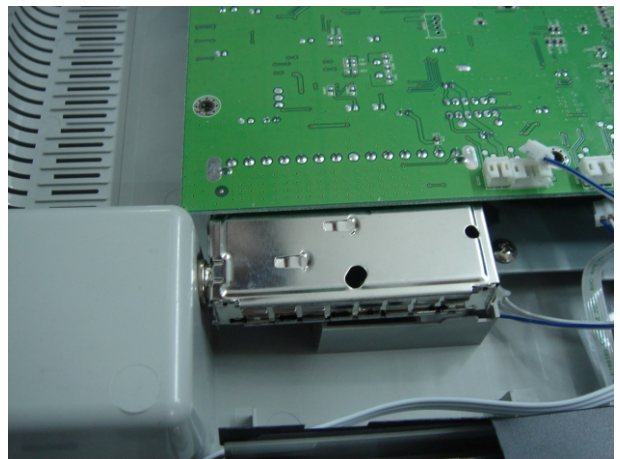

10. Take out video main board. Please note that tuner of the video main board still locks on rear casing, so take out according to arrow direction.

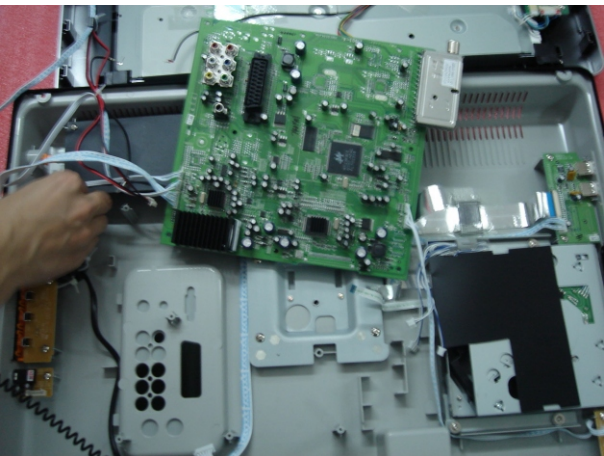

11. Take out video main board.

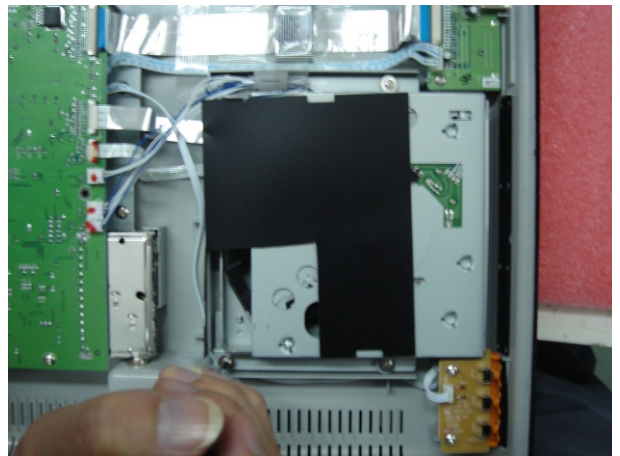

12. Take out the screw that fixes loader components and then take out loader components.

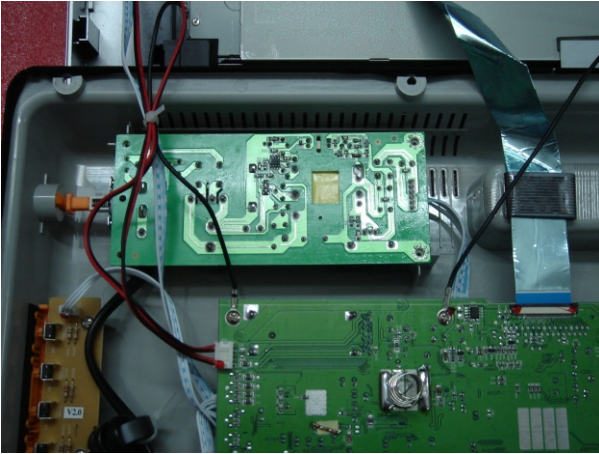

13. Take out the screw that fixes power board and take out powerboard.



14. Take out the screw that fixes inverter components.

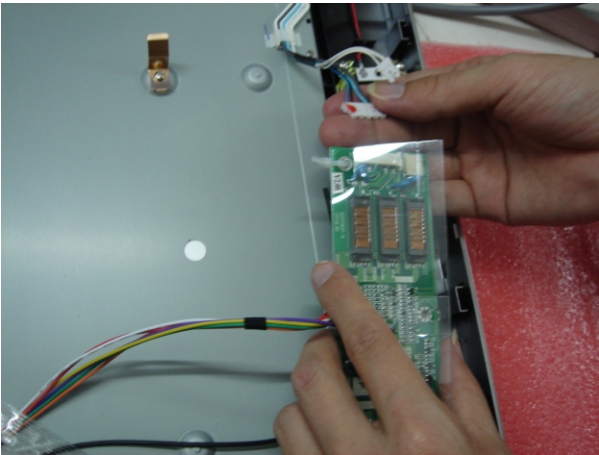

15. Unplug flat cable on inverter components and pay attention not to damage flat cable.



16. Take out the 4 fixing bracket and 4 fixing clasps that fix display screen components and the display screen components may be taken out. Now disassembly of machine is completed.

#### 4.2 Assembly process for the player

Assembly process of the player is similar to the disassembly process, only the sequence is reverse.

# Chapter Cinque

## PCB board & Circuit diagram

### Section One PCB board

#### 5.1.1 Surface layer of POWER Board

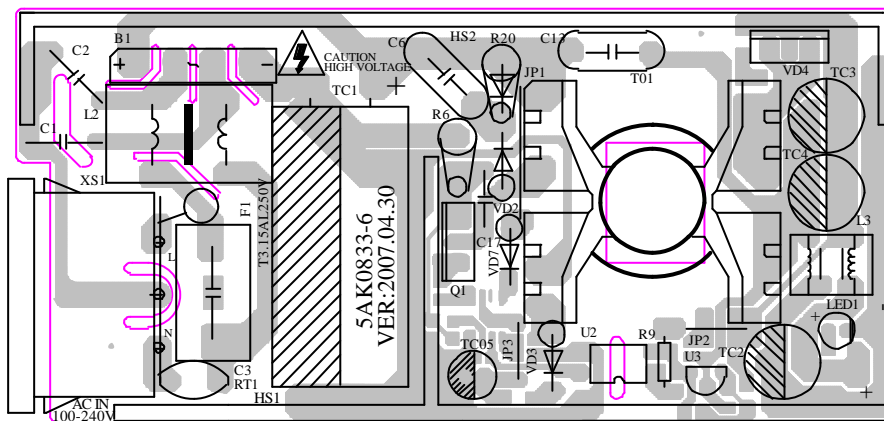

### 5.1.2 Bottom layer of POWER Board

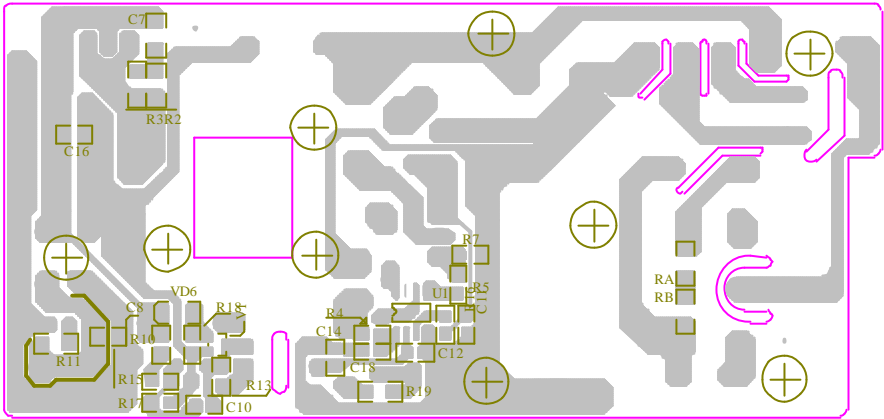



### 5.1.3 Surface layer of Boost Board

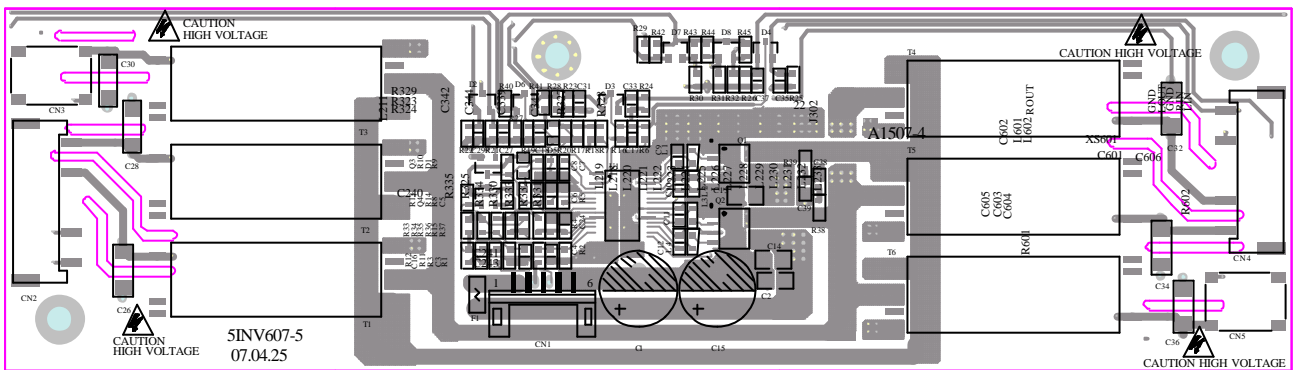

### 5.1.4 Bottom layer of Boost Board

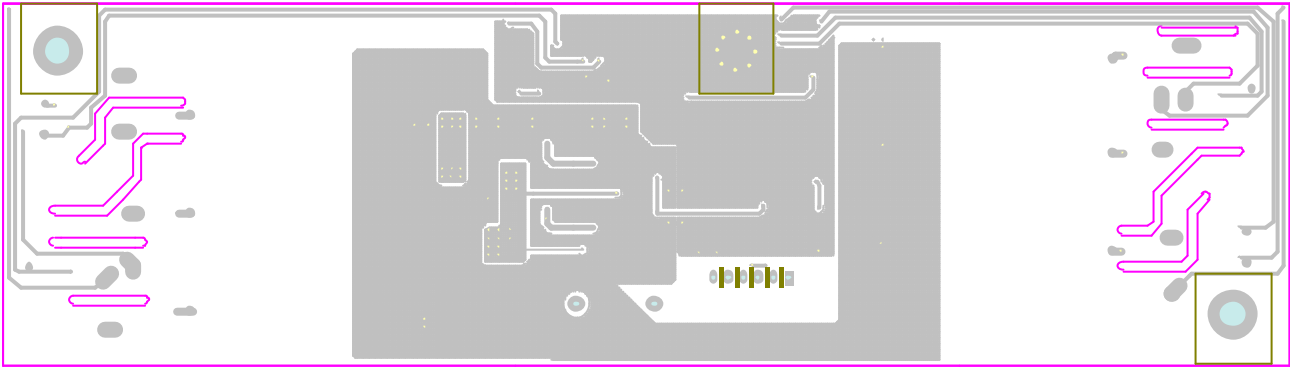

## 5.1.5 Surface layer of Main Board

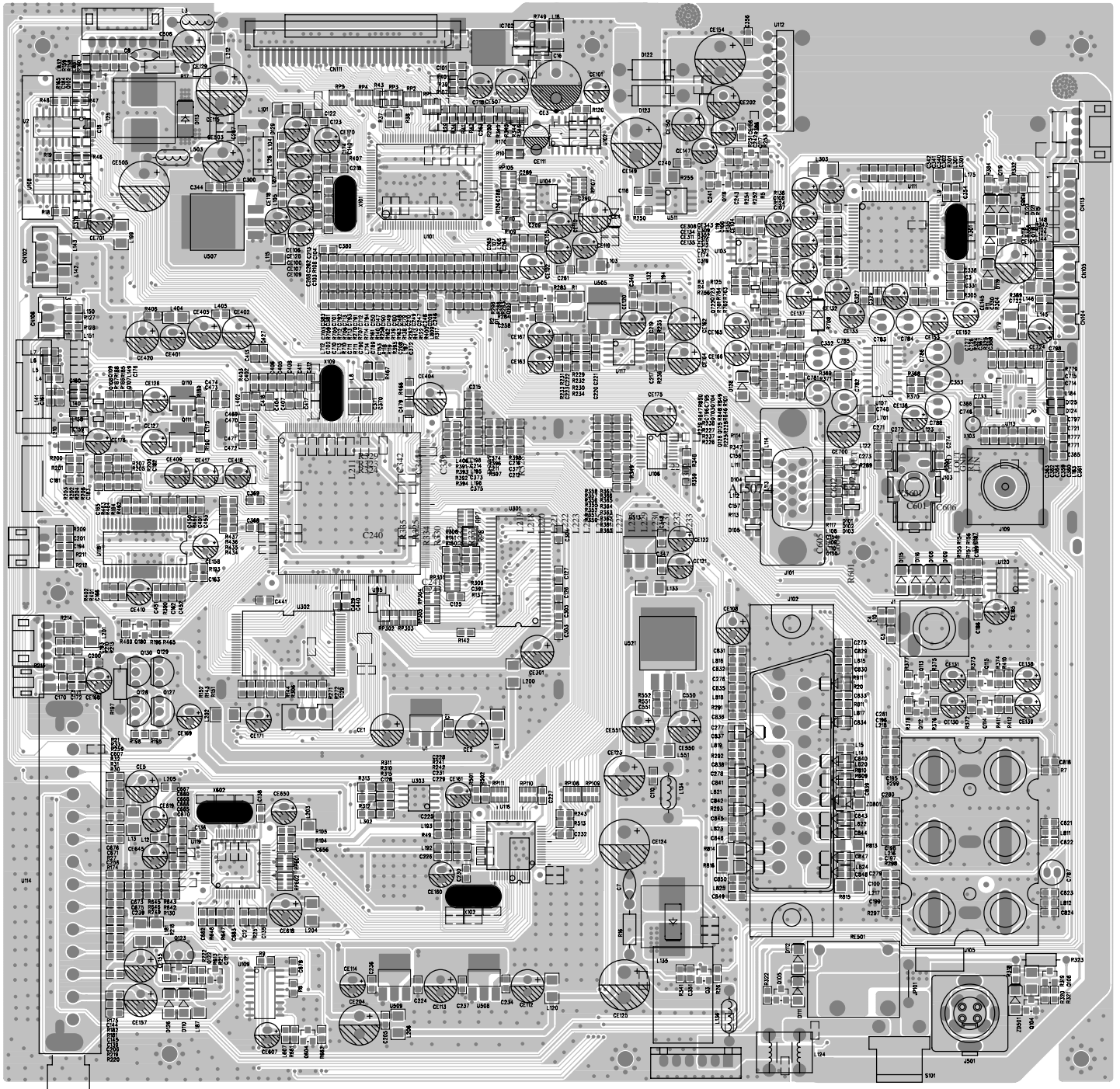

## 5.1.6 Bottom layer of Main Board

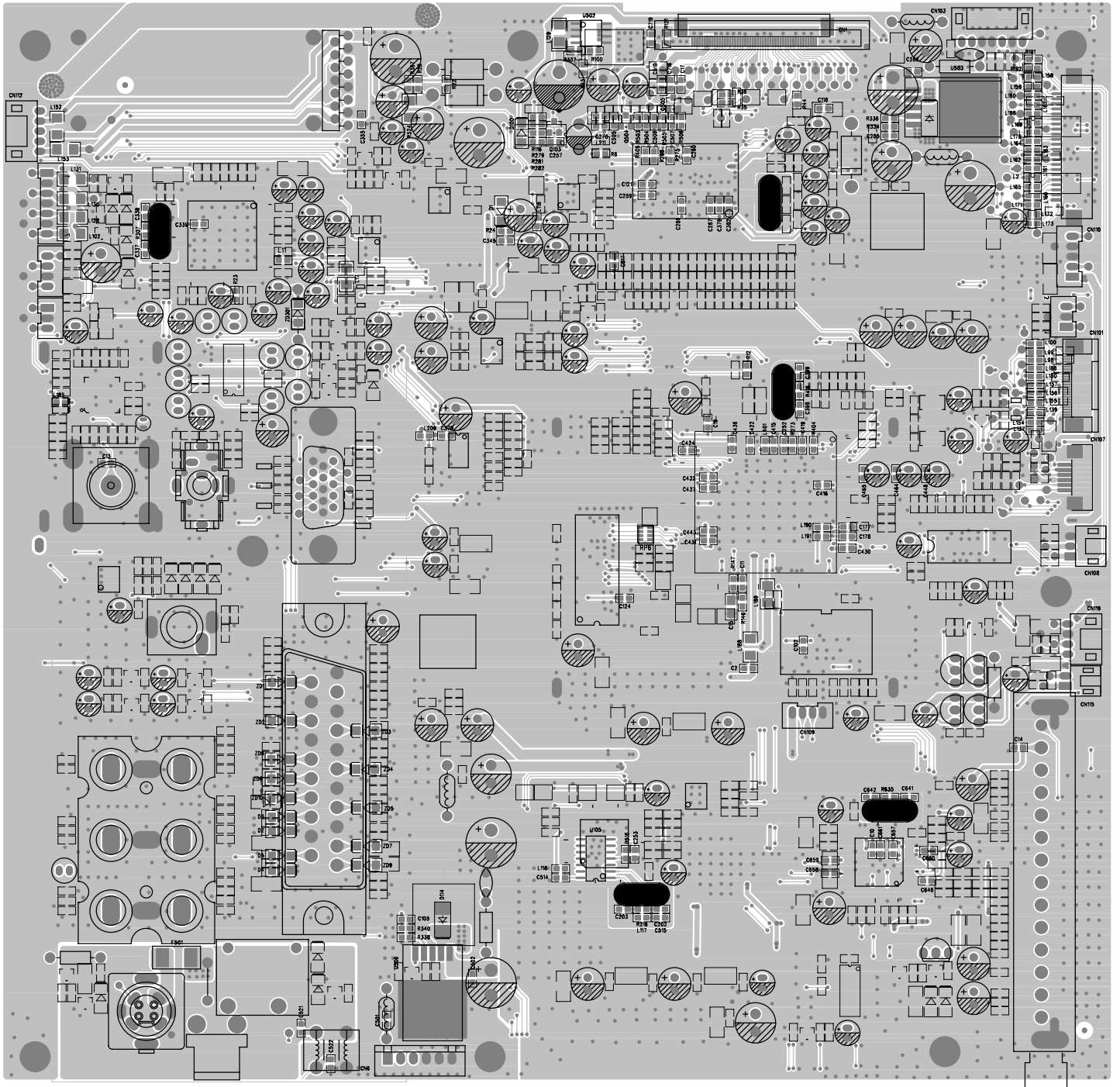



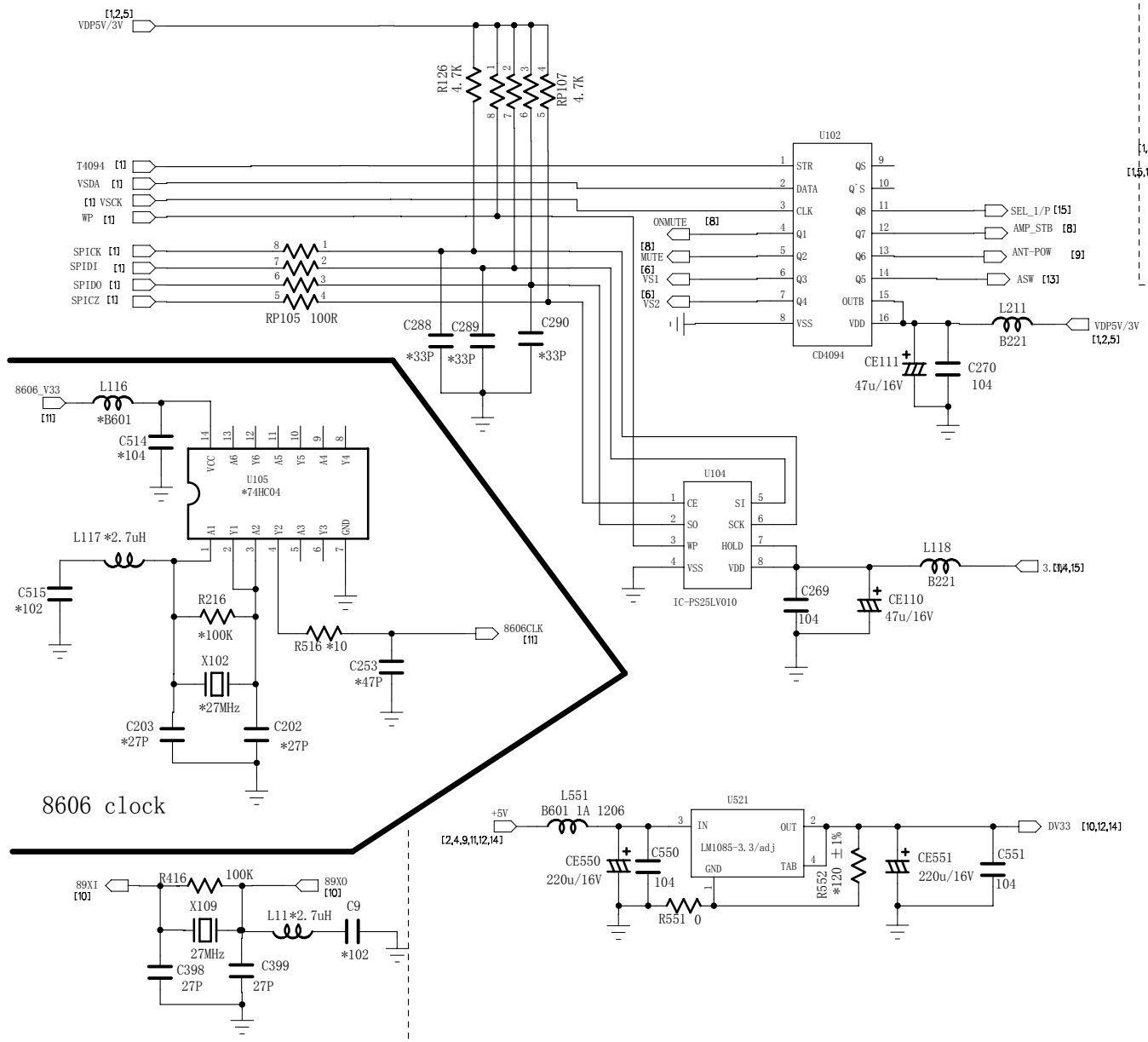

8606 clock

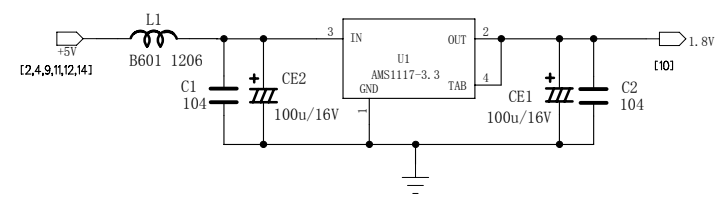
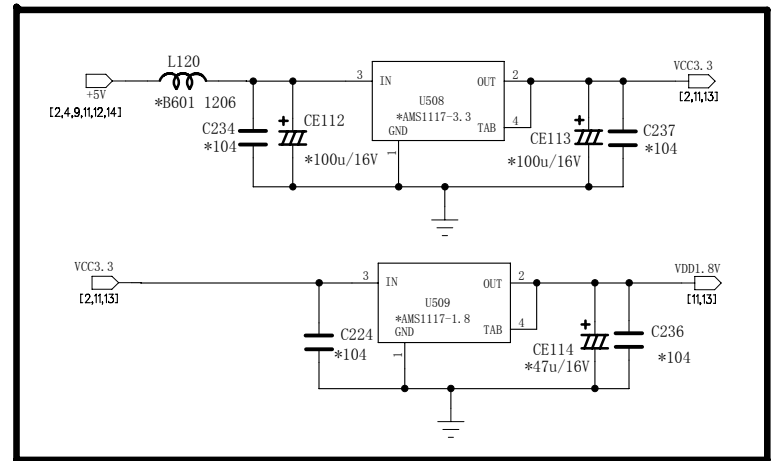
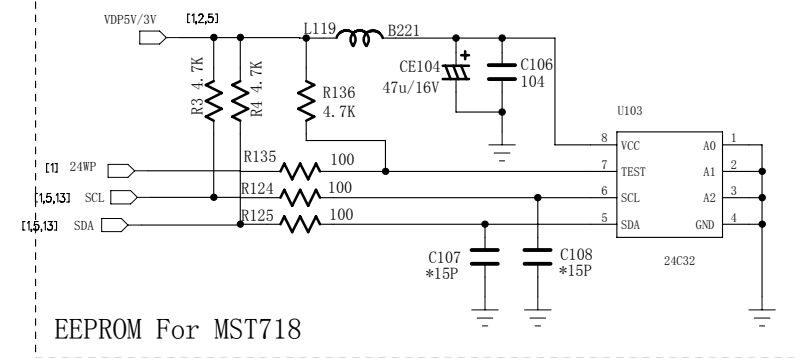

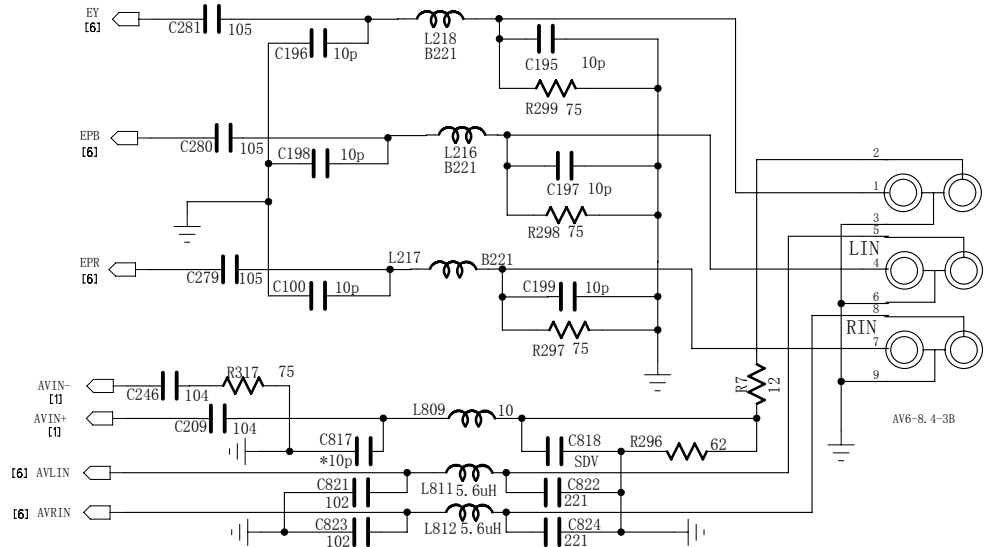
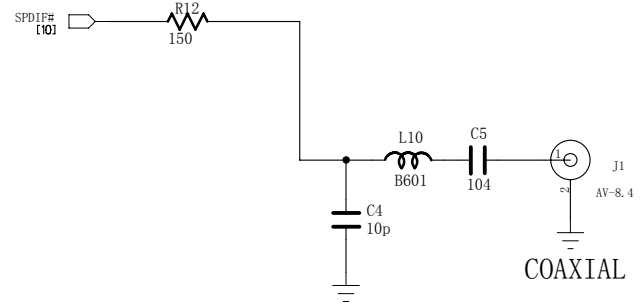
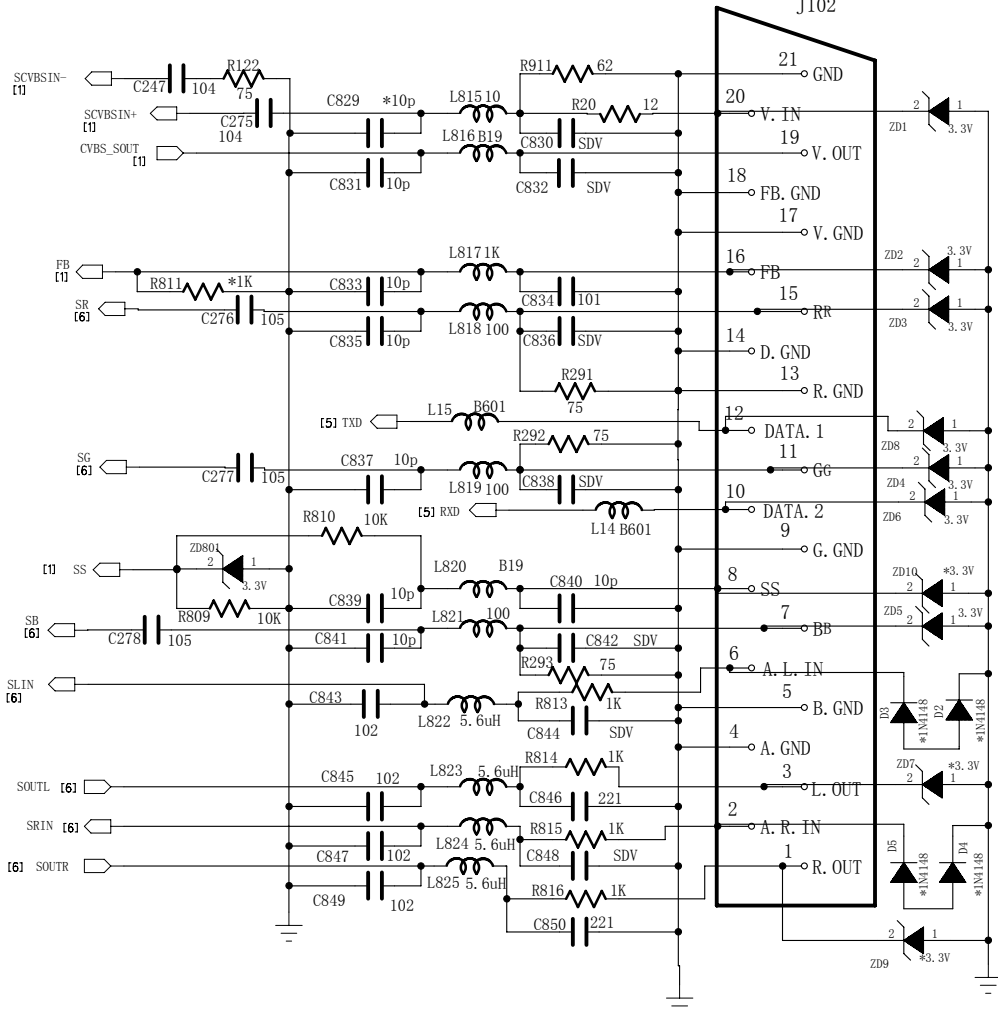
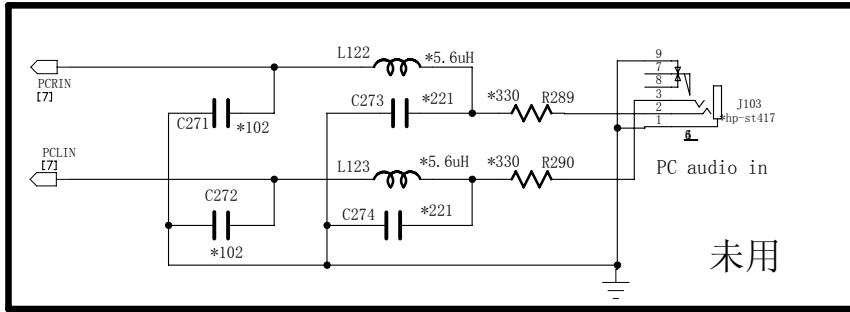

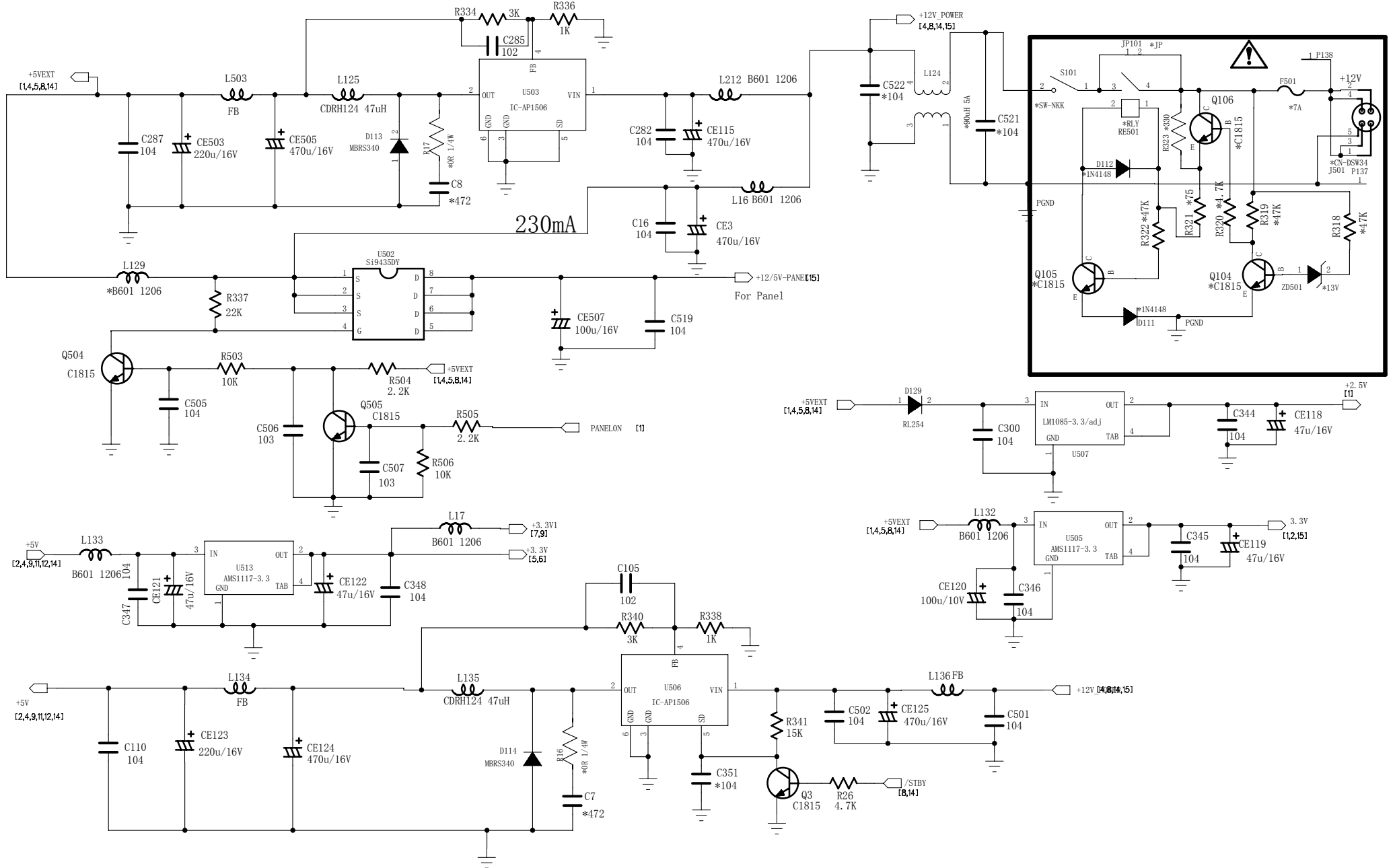



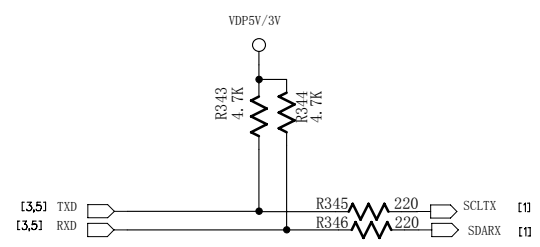
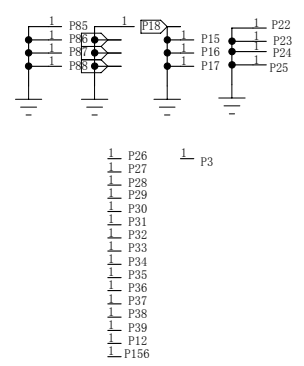
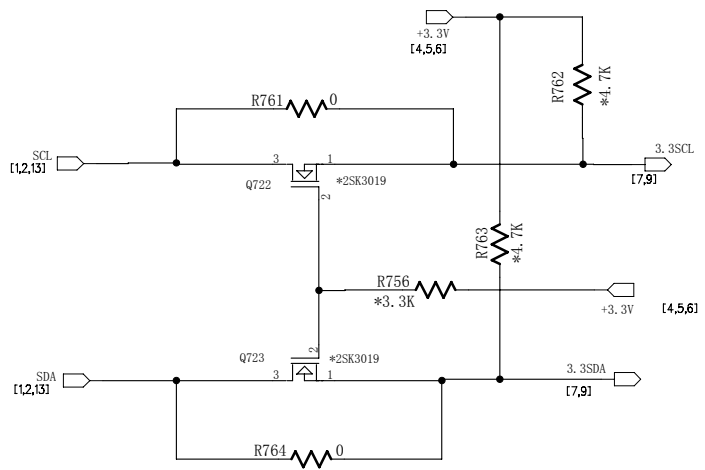
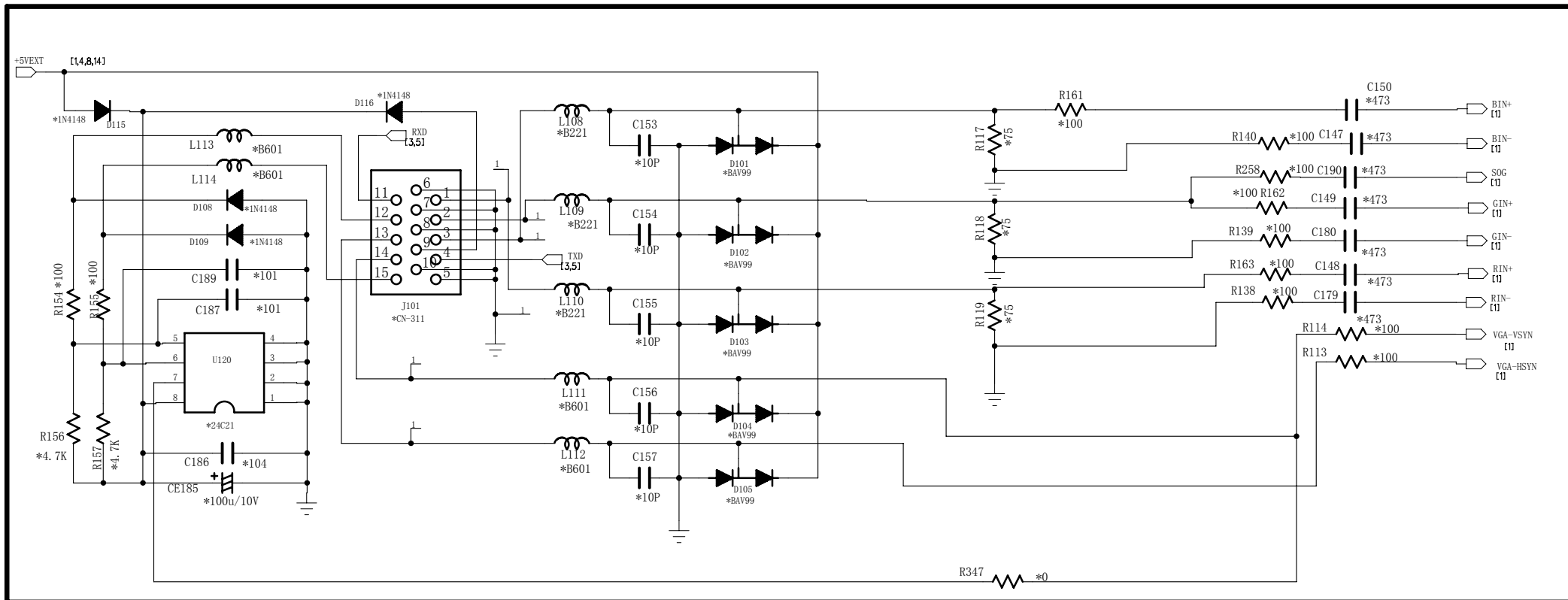

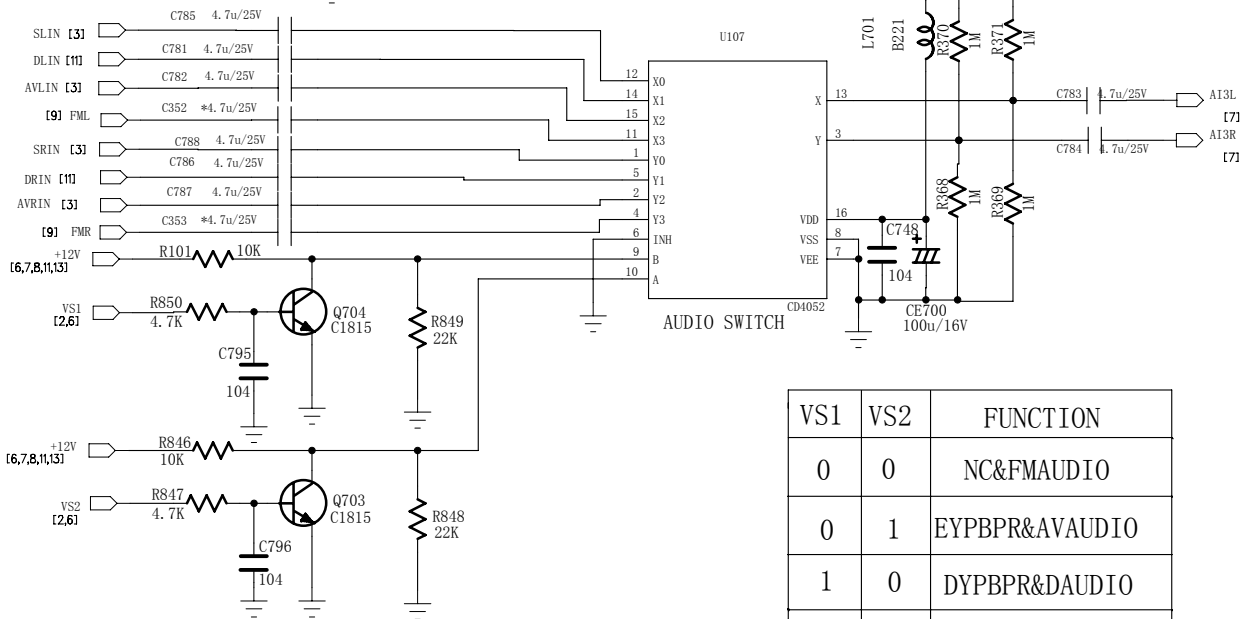
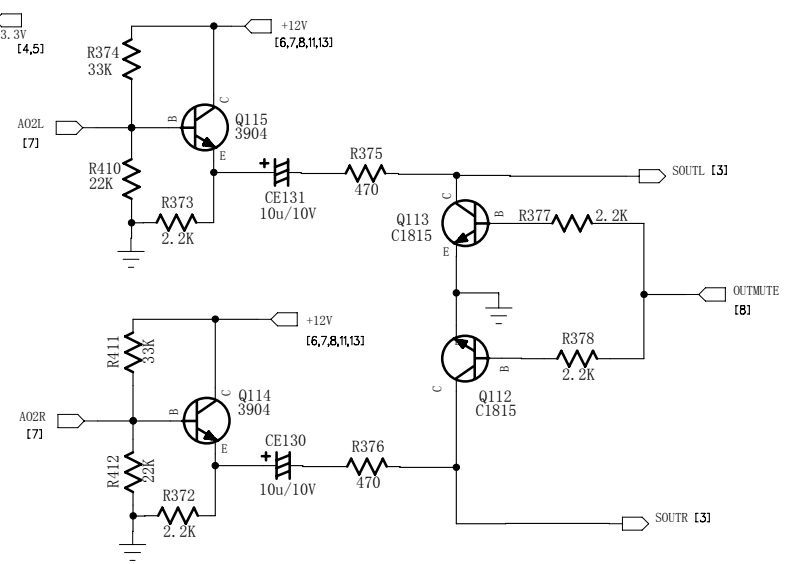
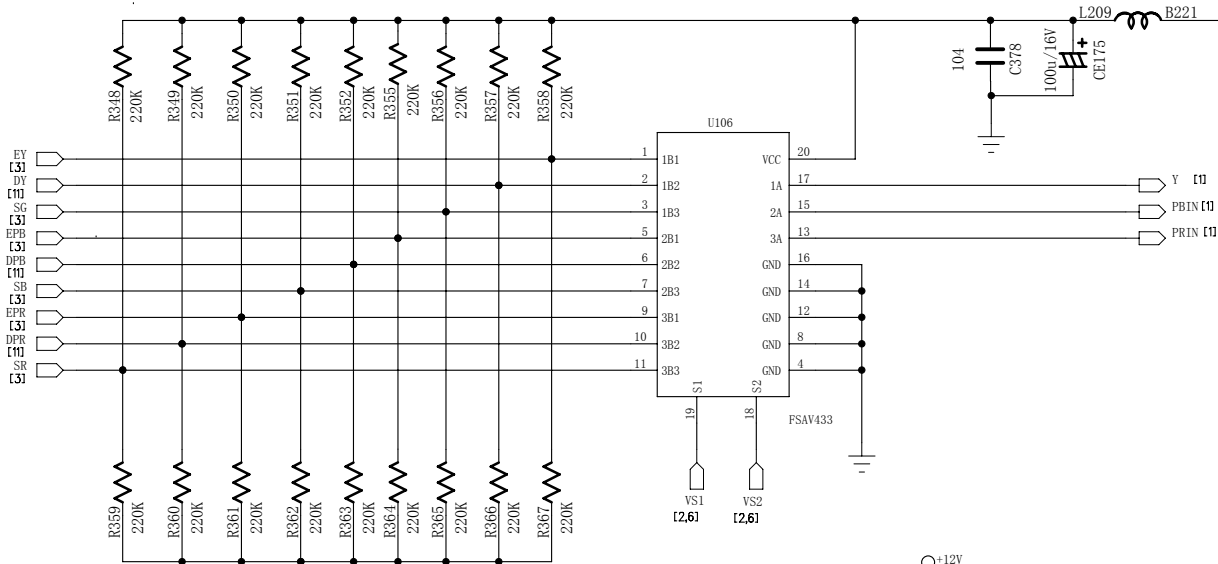

VS1	VS2	FUNCTION
0	0	NC&FMAUDIO
0	1	EYPBPR&VAUDIO
1	0	DYPBPR&DAUDIO
1	1	SRGB&SAUDIO

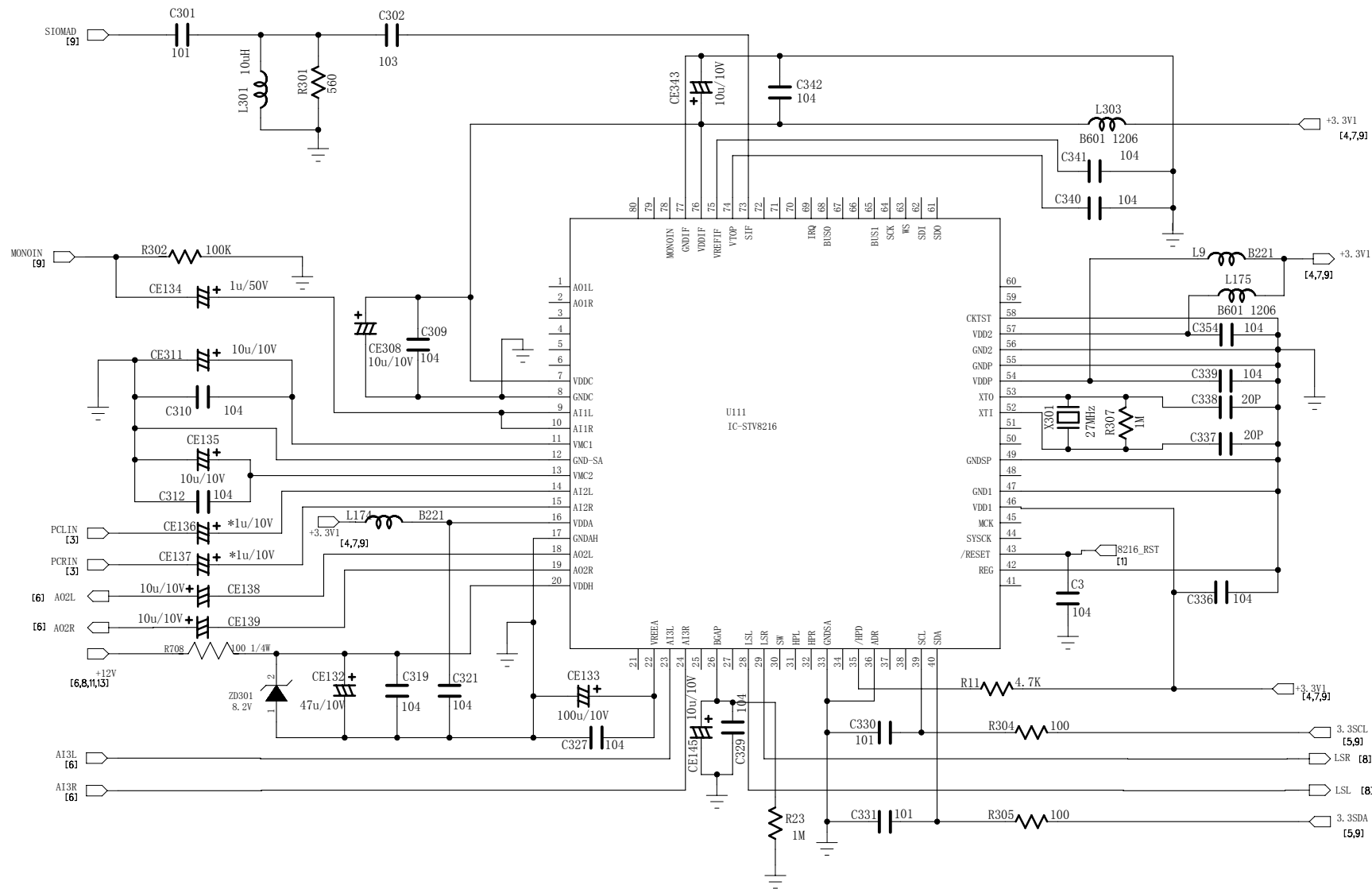



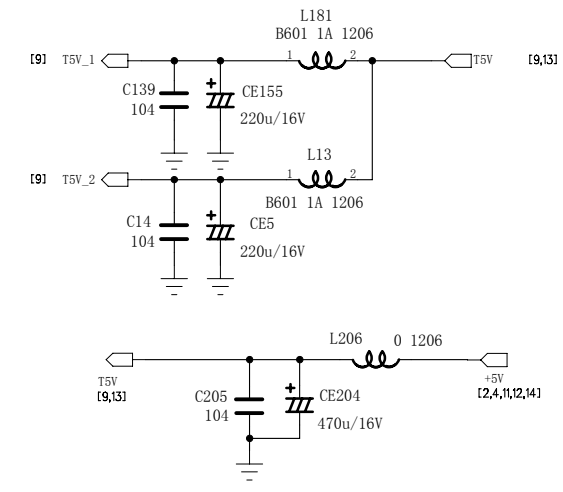
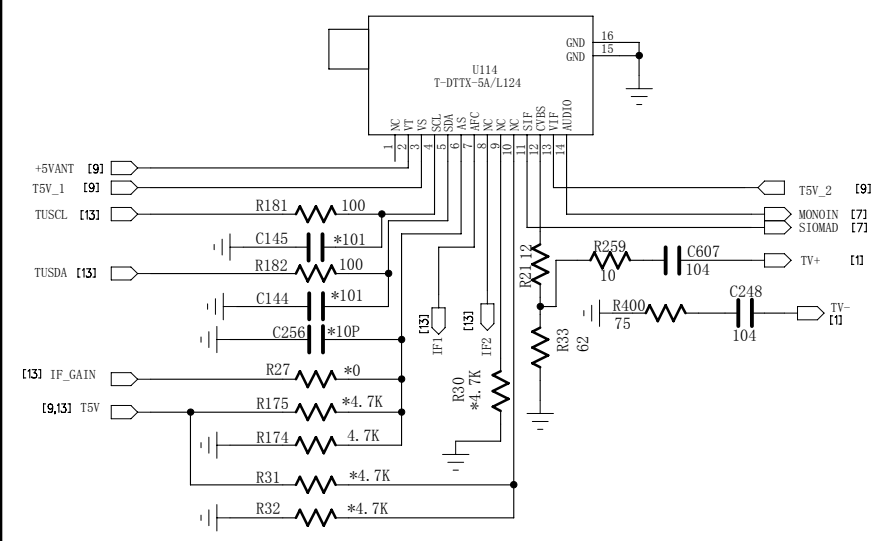
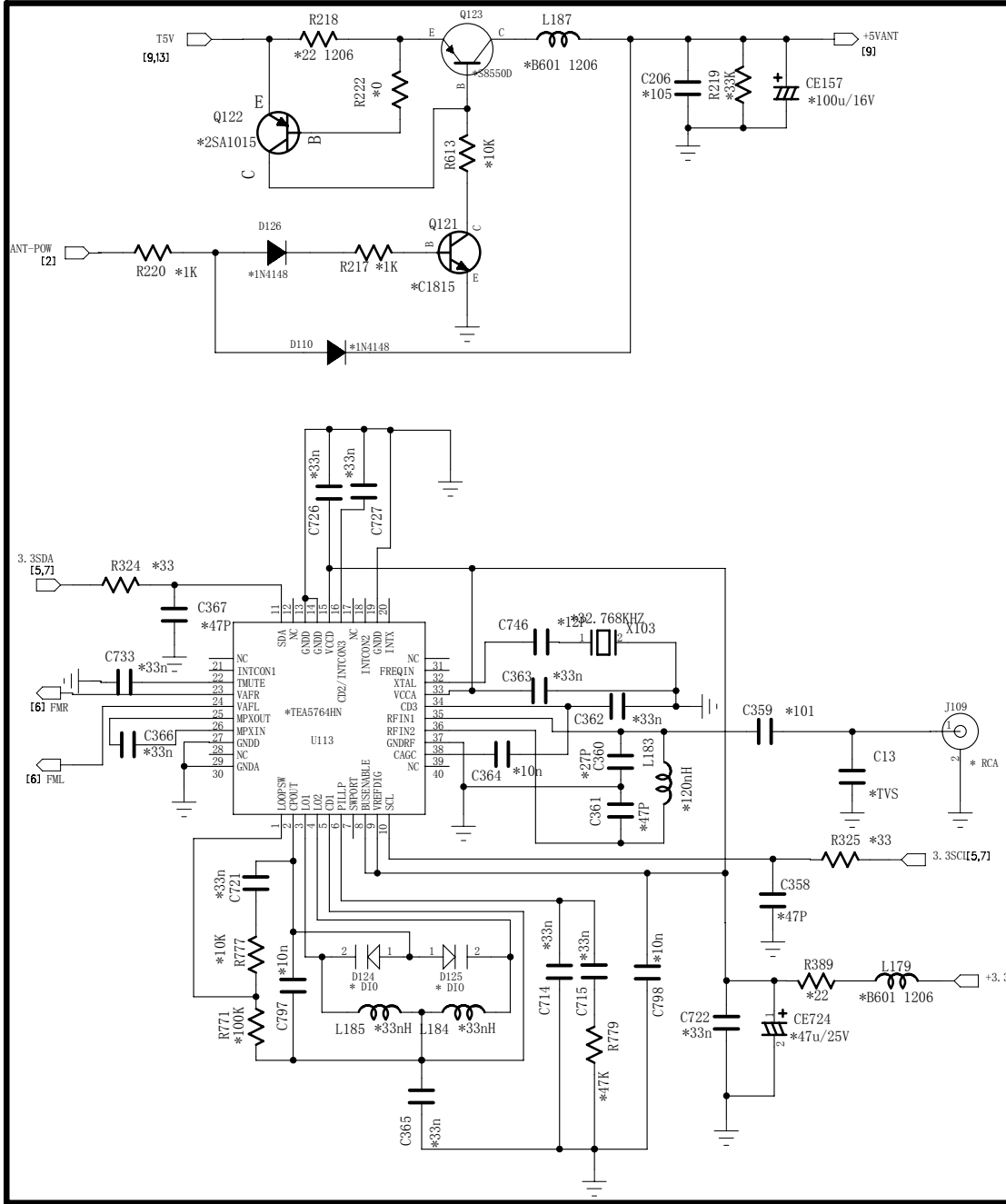

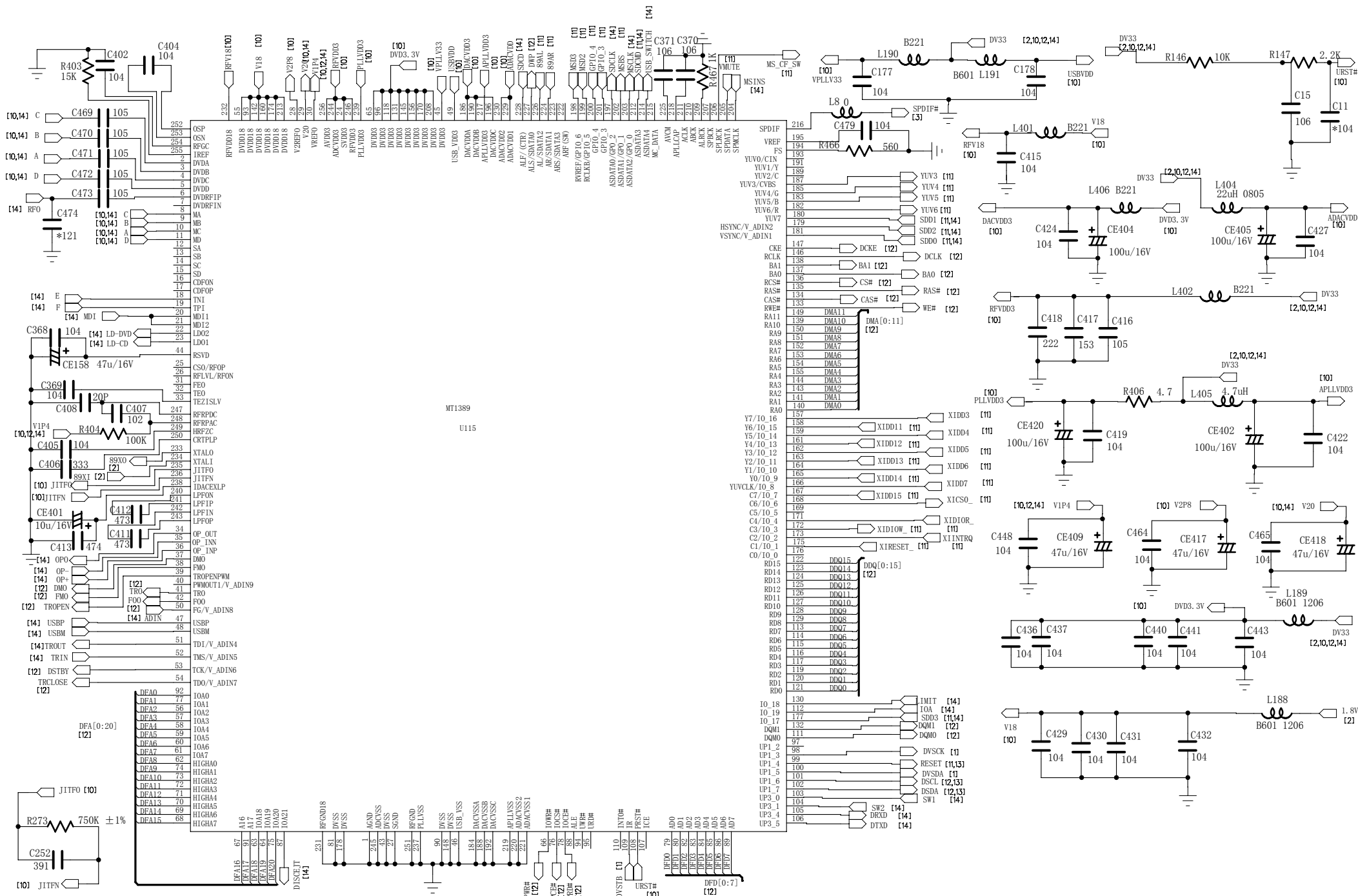



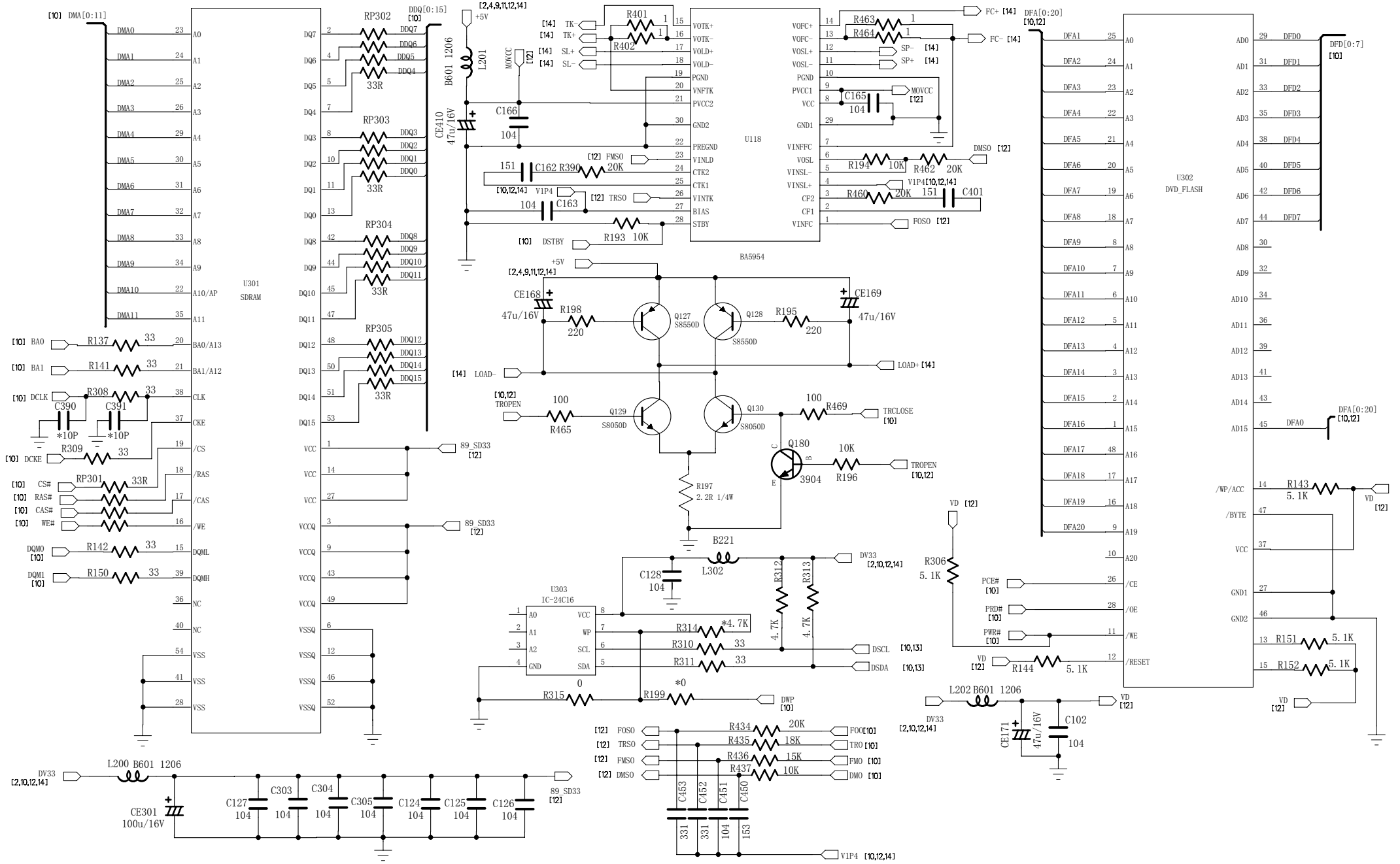



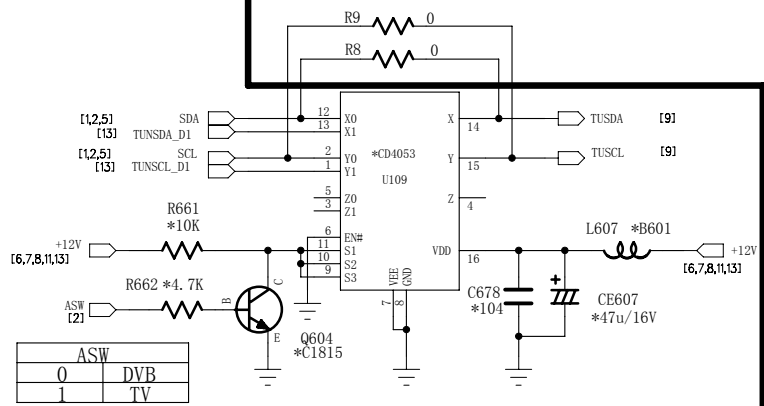
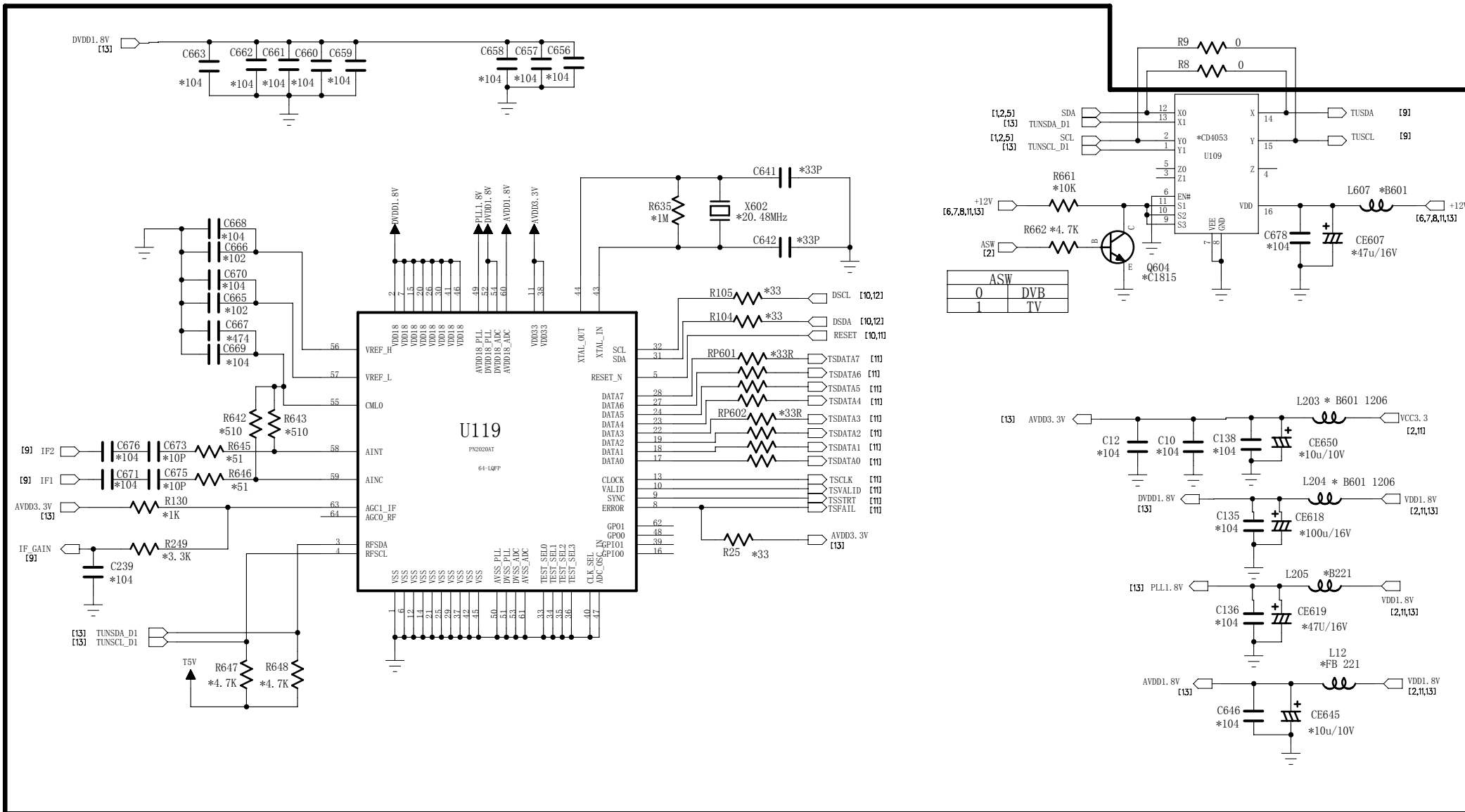

ASW	DVB
0	TV
1	

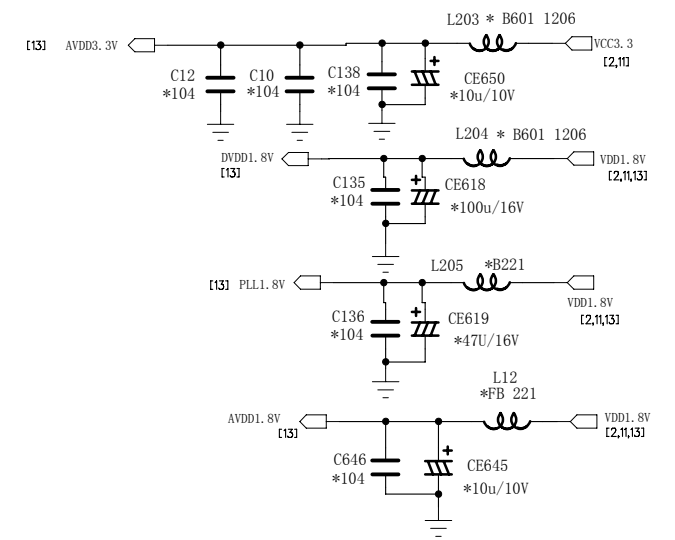

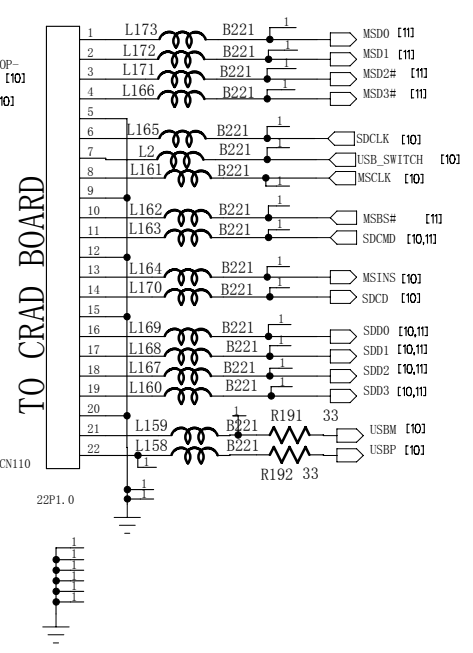
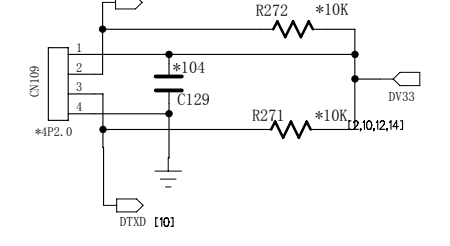
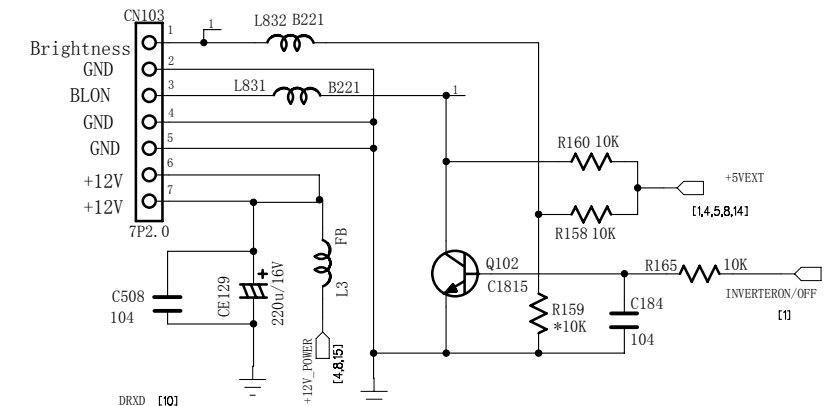
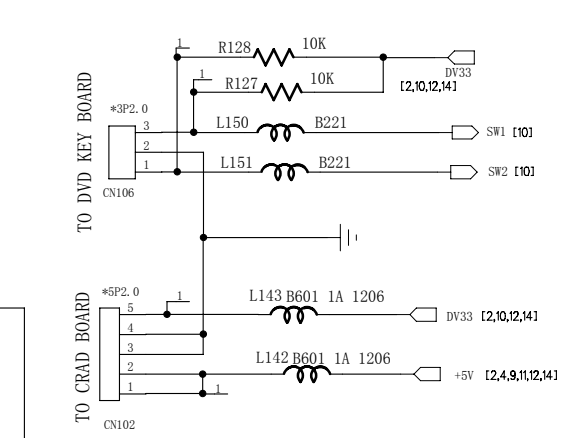
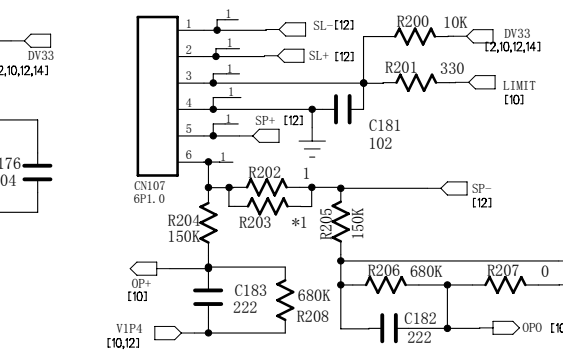
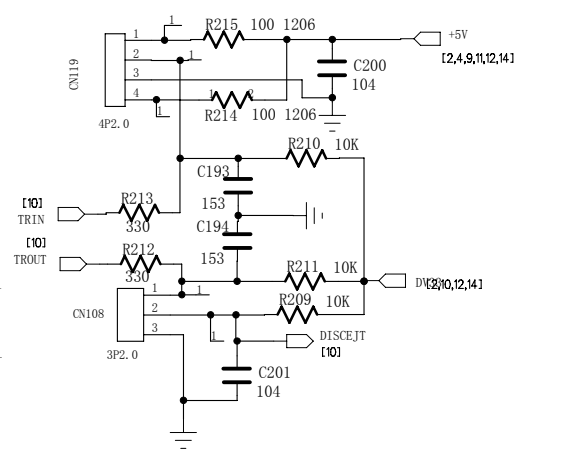
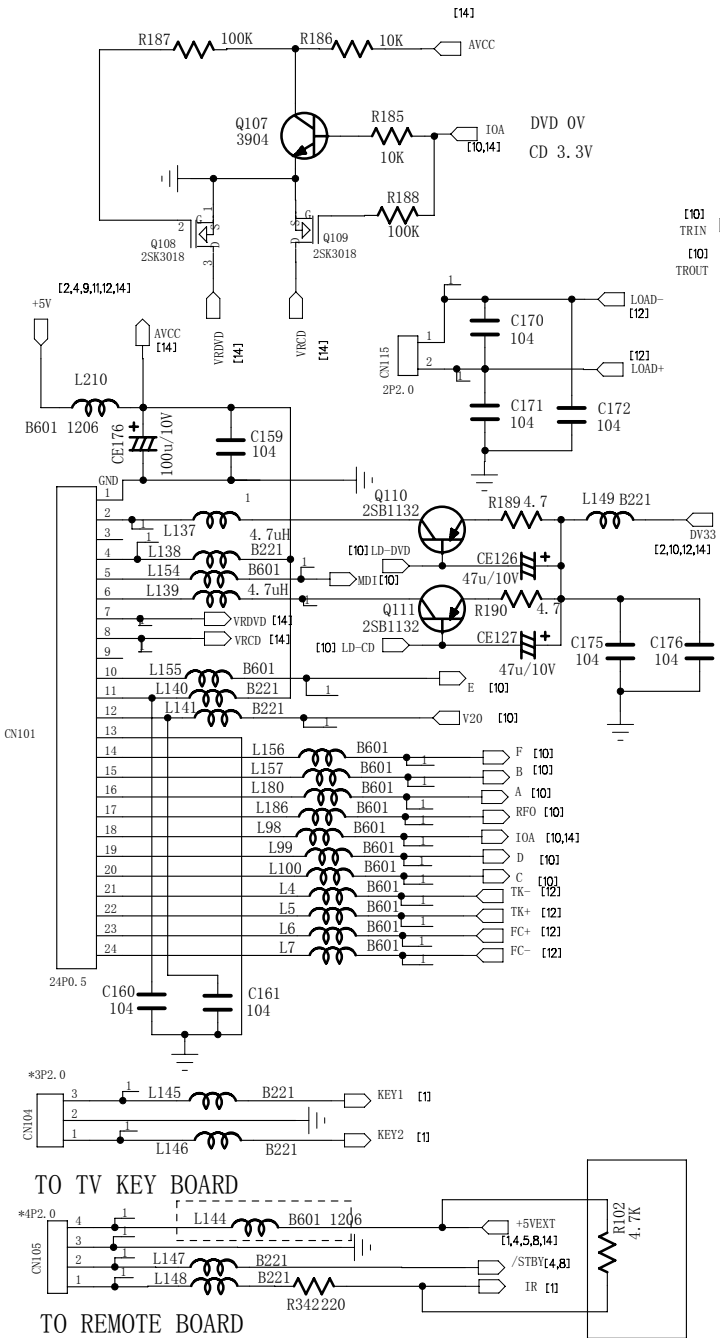

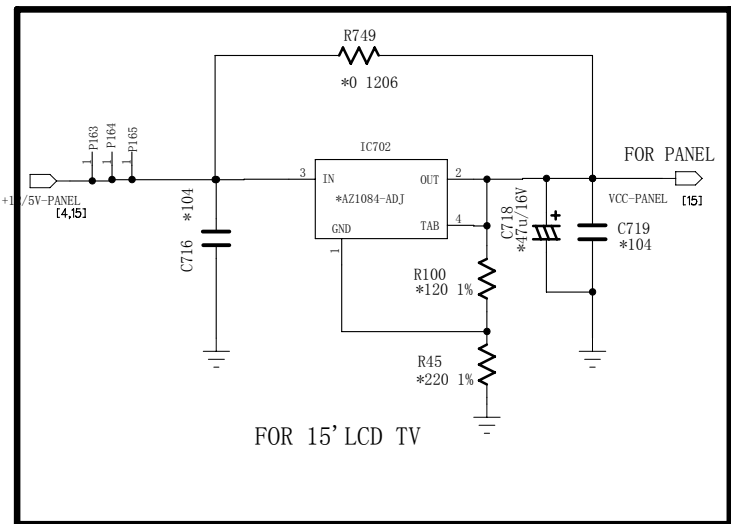
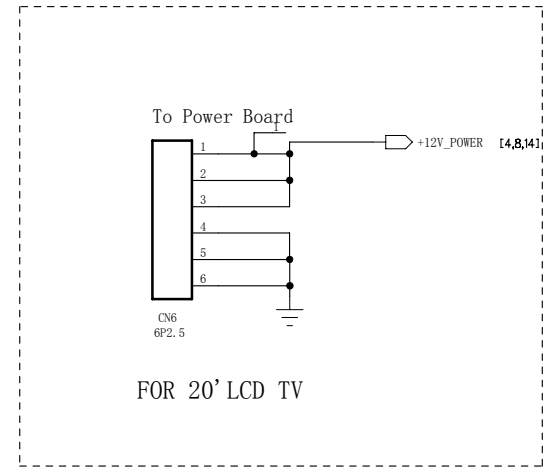
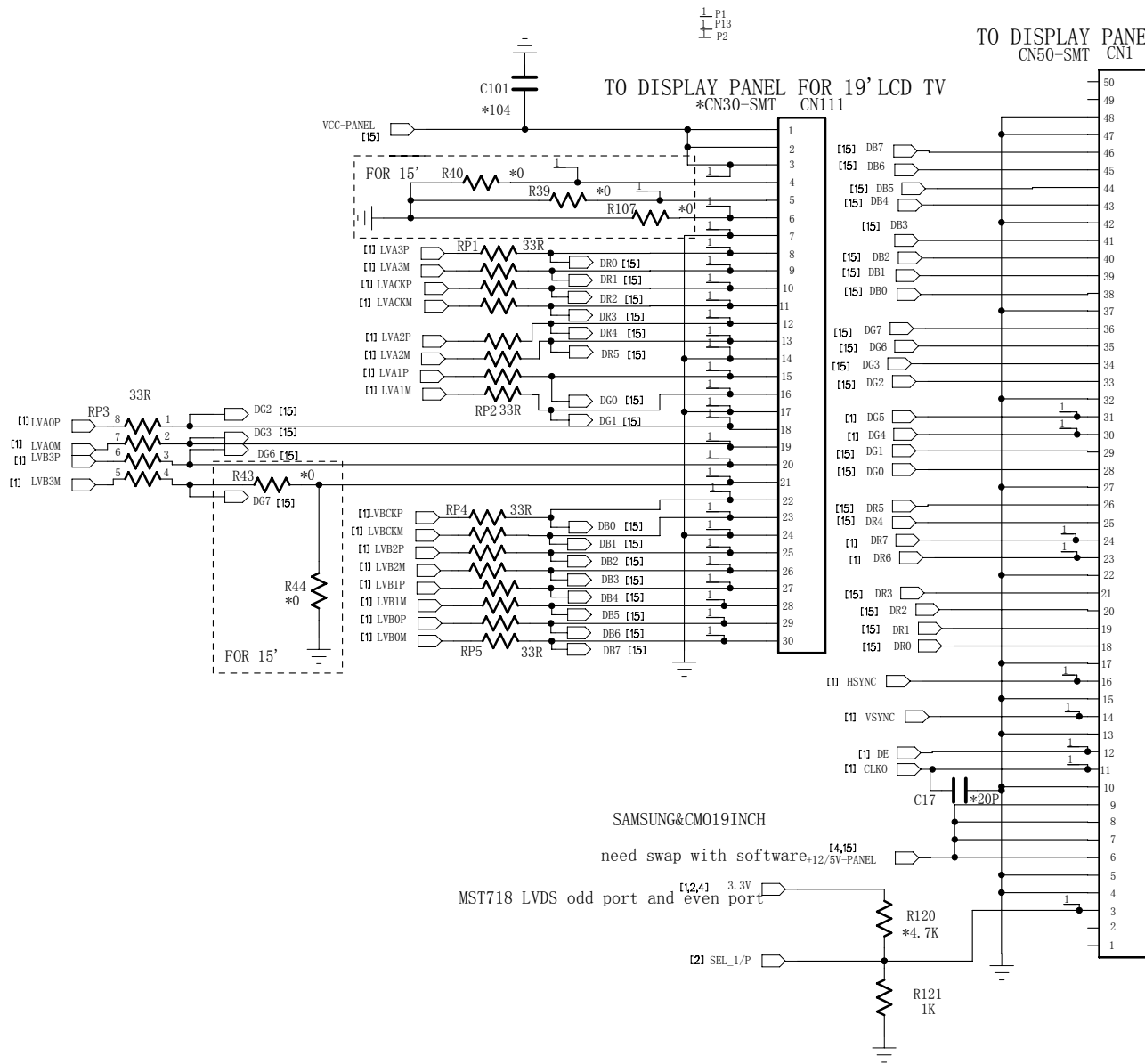

### 5.2.2 Boost board

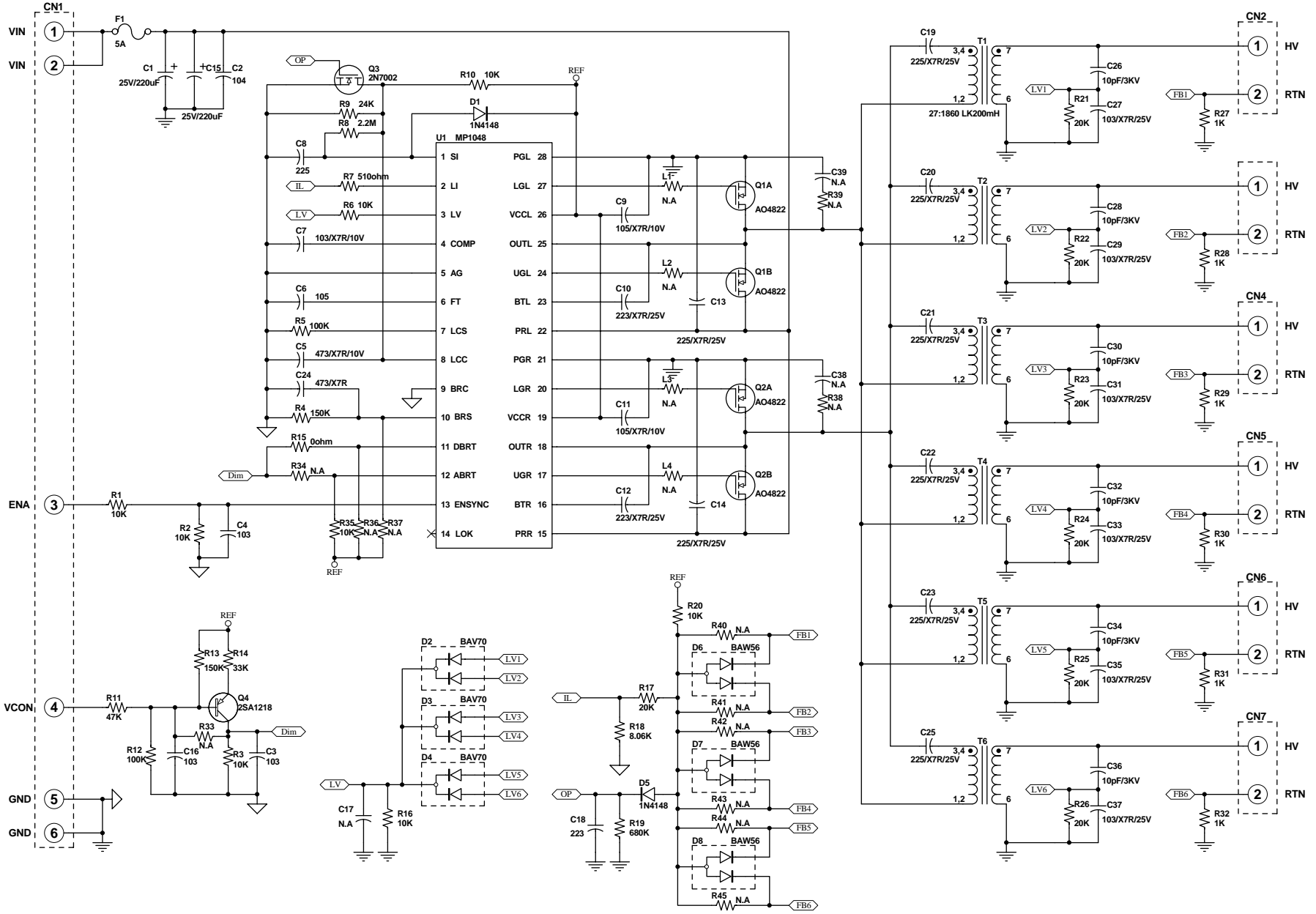

### 5.2.3 POWER board

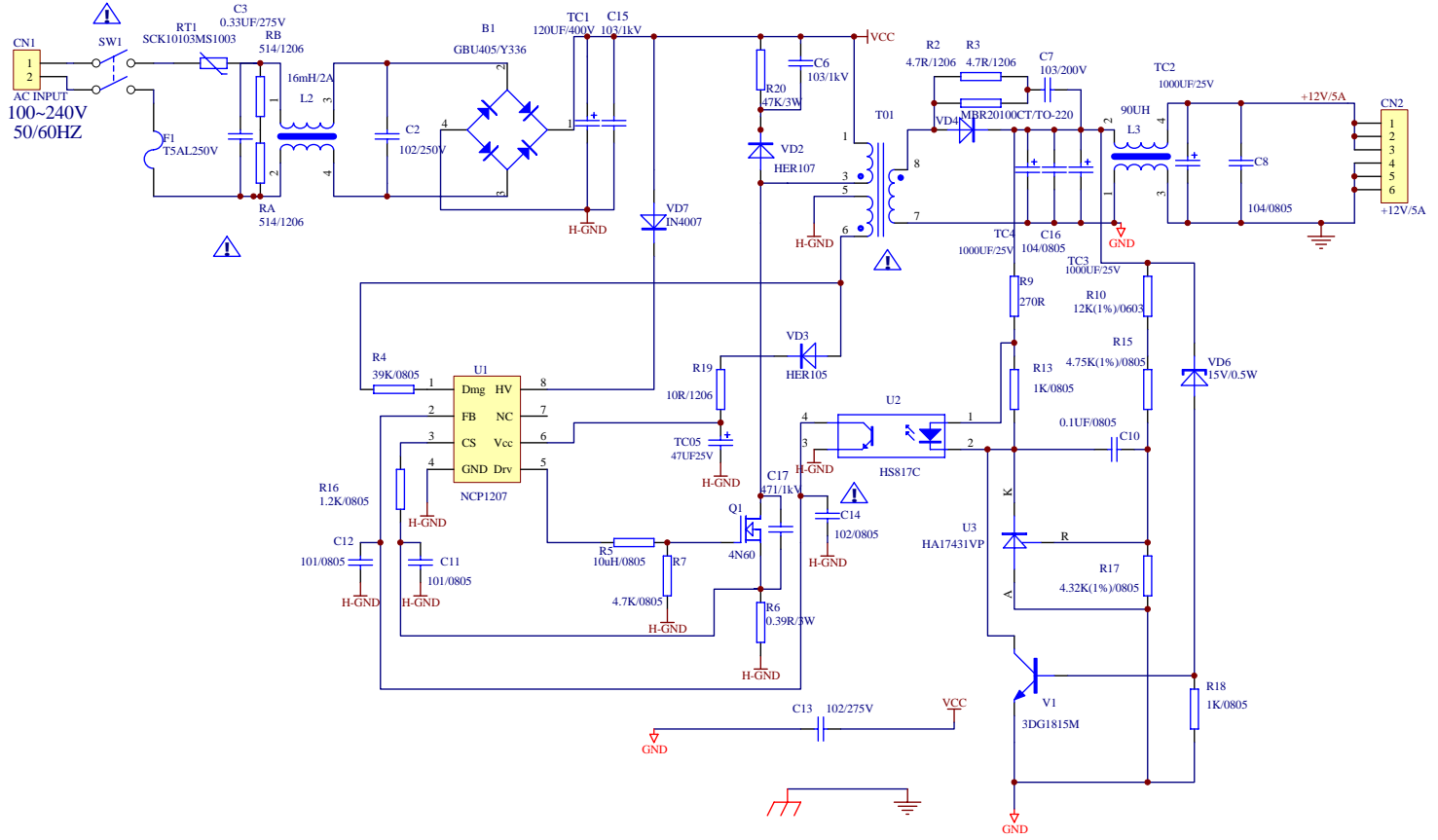

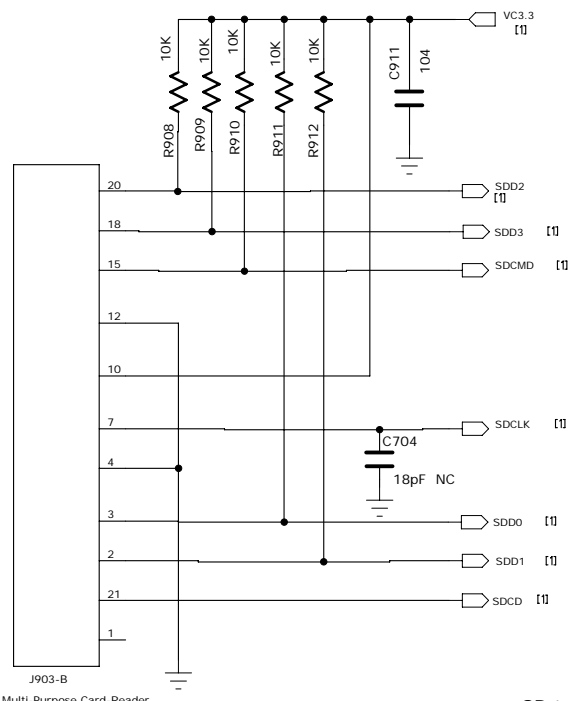

J903-B  
Multi-Purpose Card-Reader

SD type

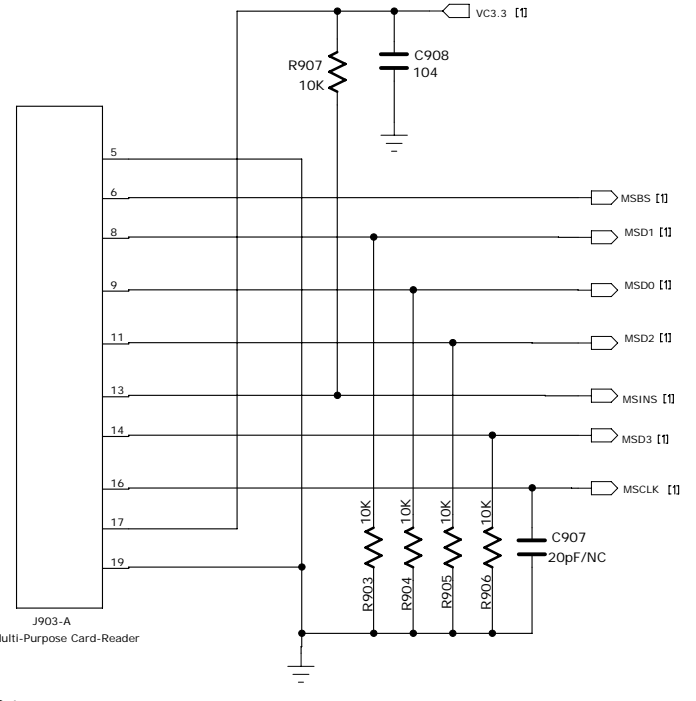

J903-A  
Multi-Purpose Card-Reader

MS type

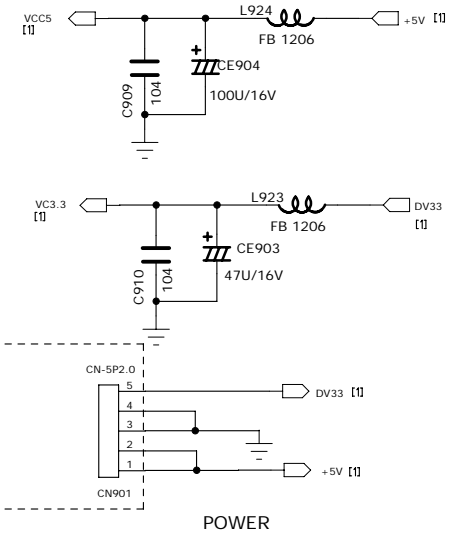

change direction  
2006-09-22

POWER

5.2.4 USB board

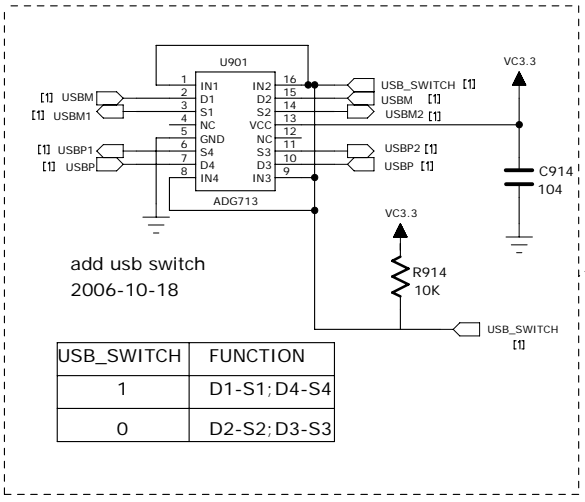
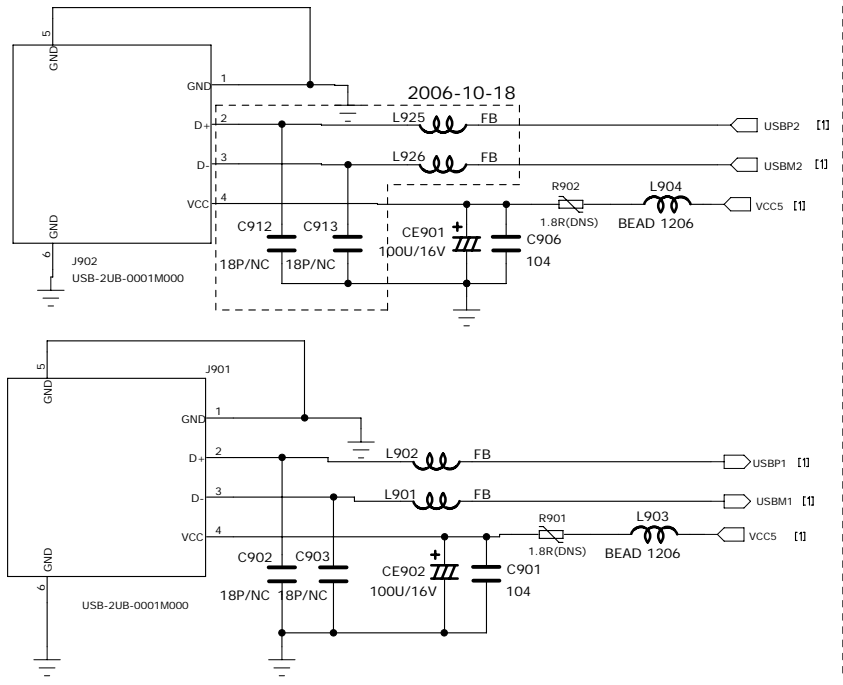

add usb switch  
2006-10-18

USB_SWITCH	FUNCTION
1	D1-S1; D4-S4
0	D2-S2; D3-S3

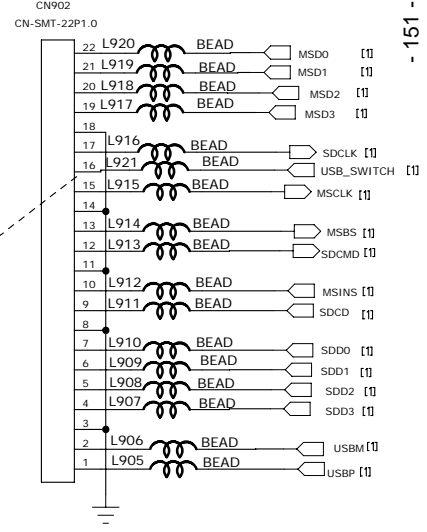

## Chapter six BOM List

MATERIAL CODE	MATERIAL NAME	SPECIFICATIONS	LOCATION
LD2006SI(RU)-2 NAVY-BLUE			
DVD KEY-PRESS BOARD: 5449477			
1940026	SOCKET	3P 2.0mm	CN601
1340064	LIGHT TOUCH RESTORE SWITCH	KFC-06-2WB L3.8	SW601 ~ SW603
0570006	DIODE	1N4148	D601,D602
1564582	PCB	J1903-0	
LD2006SI(RU)-2 NAVY-BLUE			
EARPHONE BOARD 5449436			
1980061	EARPHONE SOCKET	C3.5-01K	J701
0310195	SMD CAPACITOR	50V 221±10% 7R 0603	C701,C702
0310066	SMD CAPACITOR	50V 102±10% 7R 0603	C703,C704
0260200	CD	CD11C 16V47U±20%5×7 2	C705,C706
0390301	SMD MAGNETIC BEADS	600O/100MHZ±25% 3216	L701,L702
0090135	SMD RESISTOR	1/8W 100O±5% 1206	R701,R702
1940023	SOCKET	7P 2.0mm	CN701
1564671	PCB	H1903-1	
LD2006SI(RU)-2 NAVY-BLUE			
MAINBOARD 21903-4 1.3/Ver2.00			
0000375	CARBON FILM RESISTOR	1/42.2O±5%	R197
0000276	CARBON FILM RESISTOR	1/4100O±5% SHAPED 10	R708
0090001	SMD RESISTOR	1/16W 0O±5% 0603	L8,R8,R9,R18,R19,R46,R47,R48,R207,R315,R551,R761,R764,R28,R308
0090114	SMD RESISTOR	1/8W 0O±5% 1206	R524,L206
0090272	SMD RESISTOR	1/16W 1O±5% 0603	R202,R401,R402,R463,R464
0090106	SMD RESISTOR	1/16W 4.7O±5% 0603	R189,R190,R406
0090003	SMD RESISTOR	1/16W 10O±5% 0603	L815,L809,R259
0090297	SMD RESISTOR	1/16W 12O±5% 0603	R7,R20,R21
0090005	SMD RESISTOR	1/16W 33O±5% 0603	R35~R38,R41,R42,R137,R141,R142,R150,R191,R192,R280,R310,R311
0090230	SMD RESISTOR	1/16W 47O±5% 0603	R2
0090286	SMD RESISTOR	1/16W 62O±5% 0603	R296,R911,R33
0090006	SMD RESISTOR	1/16W 75O±5% 0603	R122,R291~R293,R297~R299,R317,R391~R398,R400

MATERIAL CODE	MATERIAL NAME	SPECIFICATIONS	LOCATION
0090181	SMD RESISTOR	1/16W 100O±5% 0603	L818,L819,L821,R124,R125,R135,R181,R182,R237,R238,R262,R270,R304,R305,R413,R465,R469, R705~R707,R712~R714
0090589	SMD RESISTOR	1/4W 100O±5% 1206	R214,R215
0090221	SMD RESISTOR	1/16W 120O±5% 0603	R284
0090538	SMD RESISTOR	1/4W 120O±5% 1206	R285
0090745	PRECISION SMD RESISTOR	1/16W 220O±1% 0603	R10
0090628	SMD RESISTOR	1/8W 220O±5% 1206	R1
0090008	SMD RESISTOR	1/16W 220O±5% 0603	R195,R198,R342,R345,R346
0090009	SMD RESISTOR	1/16W 330O±5% 0603	R201,R212,R213,R279
0090011	SMD RESISTOR	1/16W 470O±5% 0603	R375,R376
0090012	SMD RESISTOR	1/16W 560O±5% 0603	R301,R466
0090235	SMD RESISTOR	1/16W 820O±5% 0603	R407
0090014	SMD RESISTOR	1/16W 1K±5% 0603	L817,R121,R226,R227,R288,R336,R338,R467
0090232	SMD RESISTOR	1/16W 150O±5% 0603	R12
0090171	SMD RESISTOR	1/8W 1K±5% 1206	R813~R816
0090223	SMD RESISTOR	1/16W 2K±5%	R109,R110
0090017	SMD RESISTOR	1/16W 2.2K±5% 0603	R147,R252,R253,R281,R372,R373,R377,R378,R384,R504,R505
0090183	SMD RESISTOR	1/16W 3K±5% 0603	R334,R340
0090019	SMD RESISTOR	1/16W 4.7K±5% 0603	R3,R4,R5,R6,R11,R26,R102,R126,R136,R170,R174,R232,R234,R275,R282,R312,R313,R343,R344,R388,R409,R847,R850
0090020	SMD RESISTOR	1/16W 5.1K±5% 0603	R143,R144,R151,R152,R306
0090023	SMD RESISTOR	1/16W 10K±5% 0603	R15,R24,R101,R127,R128,R158,R160,R165,R185,R186,R193,R194,R196,R200,R209~R211,R231,R233,R239,R251,R254,R283,R286,R332,R385~R387,R437,R503,R506,R809,R810,R846,R146
0090024	SMD RESISTOR	1/16W 15K±5% 0603	R341,R403,R436
0090188	SMD RESISTOR	1/16W 18K±5% 0603	R435
0090025	SMD RESISTOR	1/16W 20K±5% 0603	R390,R434,R460,R462
0090026	SMD RESISTOR	1/16W 22K±5% 0603	R235,R236,R250,R337,R410,R412,R848,R849
0090189	SMD RESISTOR	1/16W 30K±5% 0603	R229,R230
0090028	SMD RESISTOR	1/16W 33K±5% 0603	R374,R411
0090034	SMD RESISTOR	1/16W 100K±5% 0603	R187,R188,R225,R228,R302,R404,R416
0090197	SMD RESISTOR	1/16W 150K±5% 0603	R204,R205



MATERIAL CODE	MATERIAL NAME	SPECIFICATIONS	LOCATION
0090201	SMD RESISTOR	1/16W 220K±5% 0603	R348~R352,R355~R367
0090211	SMD RESISTOR	1/16W 680K±5% 0603	R206,R208
0090319	PRECISION SMD RESISTOR	1/16W 750K±1% 0603	R273
0090109	SMD RESISTOR	1/16W 1MO±5% 0603	R108,R307,R368~R371
0100019	SMD RESISTOR NETWORKS	1/16W 33O±5% 8P	RP1~RP5,RP301~RP305,RP6,RP7,RP8
0100020	SMD RESISTOR NETWORK	1/16W 100O±5% 8P	RP105
0100005	SMD RESISTANCE NETWORK	4.7K±5% 8P	RP107
1030036	SMD PRESS SENSITIVITY RESISTOR	S1608E180C600NPT 0603	C836,C838,C842,C830,C832,C844,C848,C818
0310188	SMD CAPACITOR	50V 10P±5% NPO 0603	C4,C100,C195~C199,C831,C833,C835,C837,C839,C840,C841
0310085	SMD CAPACITOR	50V 20P±5% NPO 0603	C103,C104,C337,C338,C408
0310190	SMD CAPACITOR	50V 27P±5% NPO 0603	C398,C399
0310047	SMD CAPACITOR	50V 101±5% NPO 0603	C220,C221,C301,C330,C331,C834
0310326	SMD CAPACITOR	50V 121±5% NPO 0603	C208,C211,C214,C215,C372~C375
0310048	SMD CAPACITOR	50V 151±5% NPO 0603	C162,C401
0310049	SMD CAPACITOR	50V 221±5% NPO 0603	C822,C824,C846,C850
0310051	SMD CAPACITOR	50V 331±5% NPO 0603	C452,C453
0310052	SMD CAPACITOR	50V 391±5% NPO 0603	C252
0310066	SMD CAPACITOR	50V 102±10% 7R 0603	C105,C181,C222,C223,C285,C407,C791,C821,C823,C843,C845,C847,C849
0310068	SMD CAPACITOR	50V 222±10% 7R 0603	C182,C183,C418
0310072	SMD CAPACITOR	50V 103±10% 7R 0603	C242,C243,C302,C506,C507
0310201	SMD CAPACITOR	50V 153±10% 7R 0603	C193,C194,C417,C450
0310055	SMD CAPACITOR	16V 333±10% 7R 0603	C406
0310056	SMD CAPACITOR	16V 473±10% 7R 0603	C411,C412,C701,C712,C713,C792~C794
0310543	SMD CAPACITOR	50V 104±10% 7R 0603	C1,C2,C3,C5,C14,C16,C102,C106,C110,C116,C118,C121~C129,C139,C140,C159~C161,C163,C165,C166,C170~C172,C174~C176,C177,C178,C184,C200,C201,C205,C209,C213,C217~C219,C240,C241,C246,C247,C248,C257~C262,C264~C270,C275,C282,C287,C300,C303~C305,C309,C310,C312,C319,C321,C327,C329,C336,C339~C342,C344~C348,C354~C356,C368,C369,C378~C383,C402,C404,C405,C415,C419,C422,C424,C427,C429~C432,C436,C437,C440,C441,C443,C448,C451,C464,C465,C479,C501,C502,C505,C508,C519,C550,C551,C607,C748,C795,C796
0310362	SMD CAPACITOR	16V474 +80%-20% Y5V 0603	C413

MATERIAL CODE	MATERIAL NAME	SPECIFICATIONS	LOCATION
0310234	SMD CAPACITOR	16V 105 +80%-20% Y5V 0603	C210,C212,C216,C249,C263,C276~C281,C377,C416,C469~C473
0310389	SMD CAPACITOR	10V 106 +80%-20% Y5V 0805	C370,C371,C15
0260763	NPCD	CD71T 25V4.7U±20% 5×11 2	C781~C788
0260667	CD	CD11K 50V1U±20% 5×11 2	CE100,CE106,CE107,CE134,CE156
0260515	CD	CD11K 16V10U±20%5×11 2	CE101,CE109,CE128,CE130,CE131,CE135,CE138,CE139,CE145,CE147,CE152,CE153,CE163,CE165~CE167,CE170,CE308,CE311,CE343,CE401
0260754	CD	CD11K 25V47U±20%5×11 2	CE102,CE104,CE105,CE110,CE111,CE118,CE119,CE121,CE122,CE126,CE127,CE132,CE158,CE168,CE169,CE171,CE409,CE410,CE417,CE418
0260517	CD	CD11K 10V100U±20%5×11 2	CE120,CE133,CE176
0260774	CD	CD11K 16V100U±20%6.3×11 2.5	CE1,CE2,CE4,CE162,CE164,CE175,CE202,CE301,CE402,CE404,CE405,CE420,CE507,CE700
0260664	CD	CD11K 16V220U±20% 6.3×11 2.5	CE5,CE108,CE129,CE150,CE151,CE155,CE550,CE551
0260740	CD	CD288Z 16V220U±20%8×12	CE123,CE503
0260653	CD	CD11K 16V470U±20%8×14 3.5	CE204
0260656	CD	CD288H 16V470U±20% 10×12 5	CE3,CE115,CE124,CE125,CE149,CE154,CE505
0390052	MAGNETIC BEADS INDUCTOR	FB	L3,L134,L136,L503
0390188	SMD MAGNETIC BEADS	BGH1608B102L	R309
0390287	SMD MAGNETIC BEADS	190/100mHZ±25% 1608	L712~L714,L816,L820
0390095	SMD MAGNETIC BEADS	FC160822105	L2,L9,L104~L107,L118,L119,L126,L138,L140,L141,L145~L148,L150,L151,L158,L159,L182,L190,L209,L211,L216~L218,L302,L401,L402,L406,L701,L831,L832
0390300	SMD MAGNETIC BEADS	600O/100MHZ±25% 1608	L4~L7,L10,L14~L15,L98,L99,L100,L154~L157,L180,L186,L191,L149,L174
0390301	SMD MAGNETIC BEADS	600O/100MHZ±25% 3216	L1,L17,L101,L103,L115,L132,L133,L144,L175,L188,L189,L194,L200,L201,L202,L210,L303
0390446	SMD MAGNETIC BEADS	600O/100MHZ±25% 1A 3216	L13,L551,L181,L142,L143,L102,L128,L130,L131,L152,L153,L212,L16
0390096	SMD INDUCTOR	1.8UH±10% 1608	L195~L198
0390355	SMD INDUCTOR	4.7UH±10% 1608	L137,L139,L405
0390286	SMD INDUCTOR	5.6uH±10% 1608	L811~L812,L822~L825
0390170	SMD INDUCTOR	10UH±10% 1608	L301
0390385	SMD INDUCTOR	22uH±10% 2012	L404
0390529	SMD CORES INDUCTOR	47uH ±20% CDH129	L125,L135
0700148	SMD VOLTAGE REGULATOR DIODE	3.3V±5% 1/2W	ZD1~ZD6,ZD8,ZD801

MATERIAL CODE	MATERIAL NAME	SPECIFICATIONS	LOCATION
0700147	SMD VOLTAGE REGULATOR DIODE	8.2V±5% 1/2W	ZD301
0680028	SMD SCHOTTKY DIODE	MBRS340	D113,D114
0700001	SMD DIODE	LS4148	D1,D100,D118~D121,D128
0570019	DIODE	0000254	D122,D123,D129
07800509	TRIODE	S8050D BELT	Q129,Q130
07800499	TRIODE	S8550D BELT	Q127,Q128
0780193	SMD TRIODE	2S3018	Q108,Q109
0780115	SMD TRIODE	2SB1132	Q110,Q111
0780040	SMD TRIODE	3904(100-300) SO23	Q100,Q103,Q114,Q115,Q180,Q107
0780041	SMD TRIODE	3906(100-300) SO23	Q1
0780197	SMD TRIODE	C1815	Q3,Q102,Q112,Q113,Q116,Q117,Q119,Q125, Q126,Q504,Q505,Q703,Q704
0780198	SMD TRIODE	2S1015	Q118
0790021	FIELD EFFECT TRANSISTOR	IR7416 SOP	U511
0790097	FIELD EFFECT TRANSISTOR	AO4419 SO8	U511
0883191	IC	7266SA ZIP	U112
0882030	IC	S8216 TQFP	U111
0882644	IC	MT1389FE/HD(HD EDITION) QFP	U115
0883189	IC	MS718BE PQFP	U101
0883323	IC	AP1506Adj TO263-5L	U503,U506
0880768	IC	C4558 SOP	U117
0882953	IC	4641632UC60 TSOP	U301
0881329	IC	HY57V641620HG6 TSOP	U301
0882076	IC	L1085-3.3 SO263	U521
0882483	IC	AZ1085S-3.3 TO-263	U521
0882472	IC	AZ1084S-3.3 TO-263	U521
0882883	IC	FS433 TSSOP	U106
0881378	IC	B5954FP HSOP	U118
0881459	IC	D5954 SOP	U118
0790126	SMD FIELD EFFECT TRANSISTOR	FDS9435A SOP	U502
0881604	IC	24C16 SOP	U303
0883303	IC	24C16 SOP	U303
0880504	IC	24C32N SOP	U103

MATERIAL CODE	MATERIAL NAME	SPECIFICATIONS	LOCATION
0882756	IC	HE4094BT SOP	U102
0882515	IC	HE4052BT SOP	U107
0882485	IC	AZ11173.3 SO223	U505,U513
0881811	IC	L1117-3.3 SO223	U505,U513
0883245	IC	AZ1085S-2.5Z TO-263	U507
0882121	IC	18 SO223	U1
0881146	IC	L11171.8 SO223	U1
0883069	IC	AZ11171.8 SO223	U1
1020094	TUNER	JS-6H2/T121	U114
0960019	CRYSTAL OSCILLATOR	12.00MHz 49-S	X101
0960020	CRYSTAL OSCILLATOR	27.00MHz 49-S	X109,X301
1940170	SOCKET	2P 2.0mm STRAIGHT CURVING	CN115
1940216	SOCKET	3P 2.0mm FLEX INSERT	CN108
1940141	SOCKET	4P 2.0mm STRAIGHT FLEX	CN119
1940160	SOCKET	5P 2.0mm STRAIGHT FLEX	CN112
1940209	SOCKET	7P 2.0mm RIGHANGLE	CN103
1940211	CABLE SOCKET	50P 0.5mm SMD,NEXT MEET WITH CLASP	CN1
1940006	SOCKET	6P 2.5mm	CN6
1940198	CABLE SOCKET	6P 1.0mm SMD,SUBMIT MEET WITH CLASP	CN107
1940390	CABLE SOCKET	22P 1.0mm SMD NEXT MEET WITH CLASP	CN110
1940094	CABLE SOCKET	24P 0.5mm SMD SUBMIT MEET WITH CLASP	CN101
1860060	SCART SOCKET	102 STRAIGHT INSERT	J102
1910277	TERMINAL SOCKET	AV6-8.3-03PB2 STRINGHT INSERT WITH SHIELD	J105
1910269	TERMINAL SOCKET	1-8.4-7 BLACK	J1
4210185	MACHINE-TAPPING SCREW	BM 3x8H BLACK	IC7266 PRESSING PLATE SCREWS
3871722	IC PRESSING PIECE	168	IC7266 PRESSING PLATE
3580244	HEAT RADIATION PIECE	1903	IC7266 HEAT EMISSION PLATE
3580214	HEAT RADIATION PIECE	13x13x10	8216,718 HEAT EMISSION PLATE
5234712	HEAT CONDUCT DOUBLE-FACE GLUE	12.5x12.5x0.25 38810	8216,718 HEAT EMISSION PLATE
2122657	FLAT CABLE	3P140 2.0 2 PIN , WITH NEEDLE , REVERSE	DECODE BOARD: CN104, TV BUTTON BOARD: CN401

MATERIAL CODE	MATERIAL NAME	SPECIFICATIONS	LOCATION
2122611	FLAT CABLE	3P380 2.0 2 PIN , WITH L NEEDLE , REVERSE	DECODE BOARD: CN106, DVD BUTTON BOARD: CN601
2122656	FLAT CABLE	4P750 2.0 2 PIN , WITH NEEDLE , REVERSE	DECODE BOARD: CN105, REMOTE CONTROL RECEIVING BOARD: CN801
2122655	FLAT CABLE	7P190 2.0 2 PIN , WITH NEEDLE , REVERSE	DECODE BOARD: CN113, HEADPHONE BOARD: CN701
2122617	FLAT CABLE	5P210 2.0 2 PIN , WITH NEEDLE , TOGETHER DIRECTION	DECODE BOARD: CN102, USB BOARD: CN901
1633908	PCB	21903-4	
LD2006SI(RU)-2 NAVY-BLUE			
POWER BOARD 5449928			
0090521	SMD RESISTOR	1/8W 510K±5% 1206	RA,RB
0090057	SMD RESISTOR	1/10W 4.7K±5% 0805	R7
0090072	SMD RESISTOR	1/10W 39K±5% 0805	R4
0090661	SMD RESISTOR	1/4W 4.7O±5% 1206	R2,R3
0090646	SMD RESISTOR	1/8W 33O±5% 1206	R19
0390044	SMD INDUCTOR	10UH±10% 2012	R5
0090050	SMD RESISTOR	1/10W 1K±5% 0805	R13,R18
0090718	PRECISION SMD RESISTOR	1/10W 4.32K±1% 0805	R17
0090719	PRECISION SMD RESISTOR	1/10W 12K±1% 0805	R10
0090720	PRECISION SMD RESISTOR	1/10W 4.75K±1% 0805	R15
0090046	SMD RESISTOR	1/10W 470O±5% 0805	R16
0090654	SMD RESISTOR	1/8W 270O±5% 1206	R9
1050010	HEAT SENSITIVITY RESISTOR	NTC 3O(5A)±20% 10D 5	RT1
0310144	SMD CAPACITOR	50V 104±10% 7R 0805	C16,C10,C8,C12
0310101	SMD CAPACITOR	50V 101±5% NPO 0805	C11
0200399	PORCELAIN CAPACITOR	CT7 250VAC 103 ±20% Y5U 10	C6
0310781	SMD CAPACITOR	100V 102±10% 7R 1206	C7
0200396	PORCELAIN CAPACITOR	1000V 221 +80%-20% SHAPED 7.5	C17
0200373	CERAMIC CAPACITOR	@C81 250VAC 102M 10 VDE	C13
0010286	METAL OXIDE FILM RESISTOR	3W 47K±5%	R20
0010291	METAL OXIDE FILM RESISTOR	30.47O±5%	R6
0210211	ANTI-JAMMING CAPACITOR	@MPX 2 275VAC 33415 VDE	C3
0260840	CD	HP 400V120U±20%25x26 10	TC1
0260769	CD	25V1000U±20% 10x20 5	TC2,TC3,TC4

MATERIAL CODE	MATERIAL NAME	SPECIFICATIONS	LOCATION
0260672	CD	CD288H 50V47U±20%6.3×11 2.5	TC05
0410211	COMMON MODE CHOKE	VERTICAL 22mH2AF 18×F 10×8 10	L2
0410160	COMMON MODE CHOKE	VERTICAL 90UH 5A F 9×F 5×4	L3
0460648	SWITCH POWER TRANSFORMER	@PQ32-082 SJ	T01
0700123	SMD VOLTAGE REGULATOR DIODE	15V±5% 1/2W	VD6
0780197	SMD TRIODE	C1815	V1
0570050	DIODE	HER105 SHAPED 7.5mm	VD3,VD2,VD7
0680104	SCHOTTKY DIODE	MBRF20100CT TO-220	VD4
0670018	SILICON BRIDGE	GBU405 Y336	B1
0883304	IC	NCP1377 SOP	U1
1080011	PHOTOELECTRIC COUPLER	HS817	U2
08824629	IC	AZ431AZ-A TO-92 BELT	U3
1564731	PCB	@52006-1 UL	
0790114	FIELD EFFECT TRANSISTOR	S1260Z PLASTIC SEALED,TO-220	Q1
1940045	SOCKET	2P 8.0mm 2#	CN1
1940006	SOCKET	6P 2.5mm	CN2
1350089	POWER SUPPLY SWITCH	@P6059-W VDE	SW1
2300071	FUSE	@3.15AL 250V WITH CANNULA,CQC	F1
3580251	HEAT RADIATION PIECE	LT2002S(RU)	HS1,HS2
5120635	WHITE GLUE	607	
5120749	GREEN GLUE	LOCTITE638	
5120014	SILICONE GREASE HEAT CONDUCT OIL	LYCAL304	
2100007	CONNETION CORDS	F 0.6 SHAPEN 15mm	JP1
2100004	CONNETION CORDS	F 0.6 SHAPED 10mm	JP2
4210151	MACHINE-TAPPING SCREW	B3×6H WHITE NICKEL	VD4,Q1
LD2006SI(RU)-2 NAVY-BLUE			
RECEIVING BOARD OF REMOTE CONTROL		5449437	
2360002	IR SENSOR	HS0038B	S801
0000013	CARBON FILM RESISTOR	1/6330O±5%	R801
0000192	CARBON FILM RESISTOR	1/4680O±5%	R802,R803
0000034	CARBON FILM RESISTOR	1/64.7K±5%	R804
0000022	CARBON FILM RESISTOR	1/61K±5%	R805

MATERIAL CODE	MATERIAL NAME	SPECIFICATIONS	LOCATION
0260515	CD	CD11K 16V10U±20%5×11 2	CE801
07800209	TRIODE	C1815Y BELT	Q801,Q802
0620007	DUAL COLOR RADIATION DIODE	3RG 9HC-A COMMON CATHODE,RED GREEN	D801
1940141	SOCKET	4P 2.0mm STRAIGHT FLEX	CN801
5235882	SOFT SPONGE SPACER	6×6×3.5 SINGLE-FACED SOFT	SPONGE SPACER OF REMOTE CONTROL RECEIVER
1564678	PCB	B1903-1	
TRANSFER BOARD 5449927			
1940403	BTB SOCKET	21/20P 1.0mm HRS/D9-41S-1V	CN1
1940211	CABLE SOCKET	50P 0.5mm SMD,NEXT MEET WITH CLASP	CN2
1633854	PCB	G2006SI-0	
LD2006SI(RU)-2 NAVY-BLUE			
TV KEY-PRESS BOARD 5449438			
1340064	LIGHT TOUCH RESTORE SWITCH	KFC-06-2WB L3.8	SW401 ~ SW407
1940026	SOCKET	3P 2.0mm	CN401
0000160	CARBON FILM RESISTOR	1/400±5%	R401,R405
0000185	CARBON FILM RESISTOR	1/43300±5%	R402,R406
0000188	CARBON FILM RESISTOR	1/44700±5%	R403,R407
0000195	CARBON FILM RESISTOR	1/41K±5%	R408
1564583	PCB	41903-0	
LD2006SI(RU)-2 NAVY-BLUE			
USB BOARD: 5449476			
1050016	HEAT SENSITIVITY RESISTOR	PTC FRU13530V	R901,R902
0090023	SMD RESISTOR	1/16W 10K±5% 0603	R914
0090024	SMD RESISTOR	1/16W 15K±5% 0603	C902,C903,C912,C913
0310207	SMD CAPACITOR	50V 104 ±20% 7R 0603	C901,C906,C909,C910,C914
0260200	CD	CD11C 16V47U±20%5×7 2	CE903
0260206	CD	CD11C 10V100U±20%5×7 2	CE901,CE902,CE904
0390287	SMD MAGNETIC BEADS	190/100mHZ±25% 1608	L901,L902,L905,L906,L921,L925,L926
0390301	SMD MAGNETIC BEADS	6000/100MHZ±25% 3216	L903,L904,L923,L924
0882425	IC	ADG713 TSSOP	U901

MATERIAL CODE	MATERIAL NAME	SPECIFICATIONS	LOCATION
1860074	USB SOCKET	2UB-0001000	J901,J902
1940024	SOCKET	5P 2.0mm	CN901
1940390	CABLE SOCKET	22P 1.0mm SMD NEXT MEET WITH CLASP	CN902
1633754	PCB	0001097	
LD2006SI(RU)-2 NAVY-BLUE			
0882923	IC	EN29LV160AB-70TCP TSOP	U302
0882665	IC	S29AL016D70TFI02 TSOP	U302
SOFTWARE PROGRAM EPROM ROMLD2006SI2-0A(2M)0900458			
0883190	IC	P25LV020 SOP	U104