

648-M7

648FX-M7

661FX/GX-M7

Rev: 1.1

Revision History :

1. Ver A: Initial for 661FX/648FX for LGA775
2. Ver 1.0:
 - I. modify CPU pull-high
 - II. add FSB1066 select CKTs
 - III. modify Common-Choke and R0603 co-lay
 - IV. add 1394A3 header
 - V. AD1888 and ALC655 co-lay
 - VI. modify FAN CTRL CKTs
 - VII. modify VRDGD
 - VIII. add PANEL2
3. Ver 1.1:
 - I. modify for EE CPU supporting
 - II. modify SmartFAN clamp up circuit

Page Index =====

- | | |
|-------------------------------------|-------------------------------|
| 1. Cover Sheet | 21. USB Connector |
| 2. Block Diagram | 22. PCI Slot1, 2 |
| 3. Clock & Power Distribution | 23. PCI Slot3 / LANPHY |
| 4. Socket LGA775-1 | 24. LAN |
| 5. Socket LGA775-2 | 25. IEEE1394a |
| 6. Socket LGA775-3 | 26. Audio Codec |
| 7. SiS661FX-1 (HOST / AGP) | 27. Audio Interface |
| 8. SiS661FX-2 (Memory) | 28. Super I/O |
| 9. SiS661FX-3 (VGA / HyperZip) | 29. KB/MS/ROM/FDC/IR |
| 10. SiS661FX-4 (Power) | 30. COM 1,2 / LPT |
| 11. SiS964-1 (PCI / IDE / HyperZip) | 31. HM/FAN/RING/LPC |
| 12. SiS964-2 (Misc. Signals) | 32. Voltage Regulator |
| 13. SiS964-3 (USB) | 33. DUAL 5V, 3V& SB Regulator |
| 14. SiS964-4 (Power) | 34. VRD10 (CPU Vcore) |
| 15. Main Clock | 35. ATX / Panel / RTC |
| 16. Clock Buffer | 36. BOM and GPIO Attention |
| 17. DDR DIMM 1, 2 | |
| 18. DDR Termination | |
| 19. AGP slot | |
| 20. VGA / IDE Connectors | |

	SIGNATURE	DATE
DESIGNER	Prowind	
LAYOUT	ECS Layout team	
CHECK	Prowind Chiang	
APPROVAL		

 Elitegroup Computer Systems			
Title 648/661FX/661GX-M7			
Size	Document Number	Cover Sheet	Rev 1.1
Custom			
Date: Monday, March 14, 2005	Sheet	1	of 36

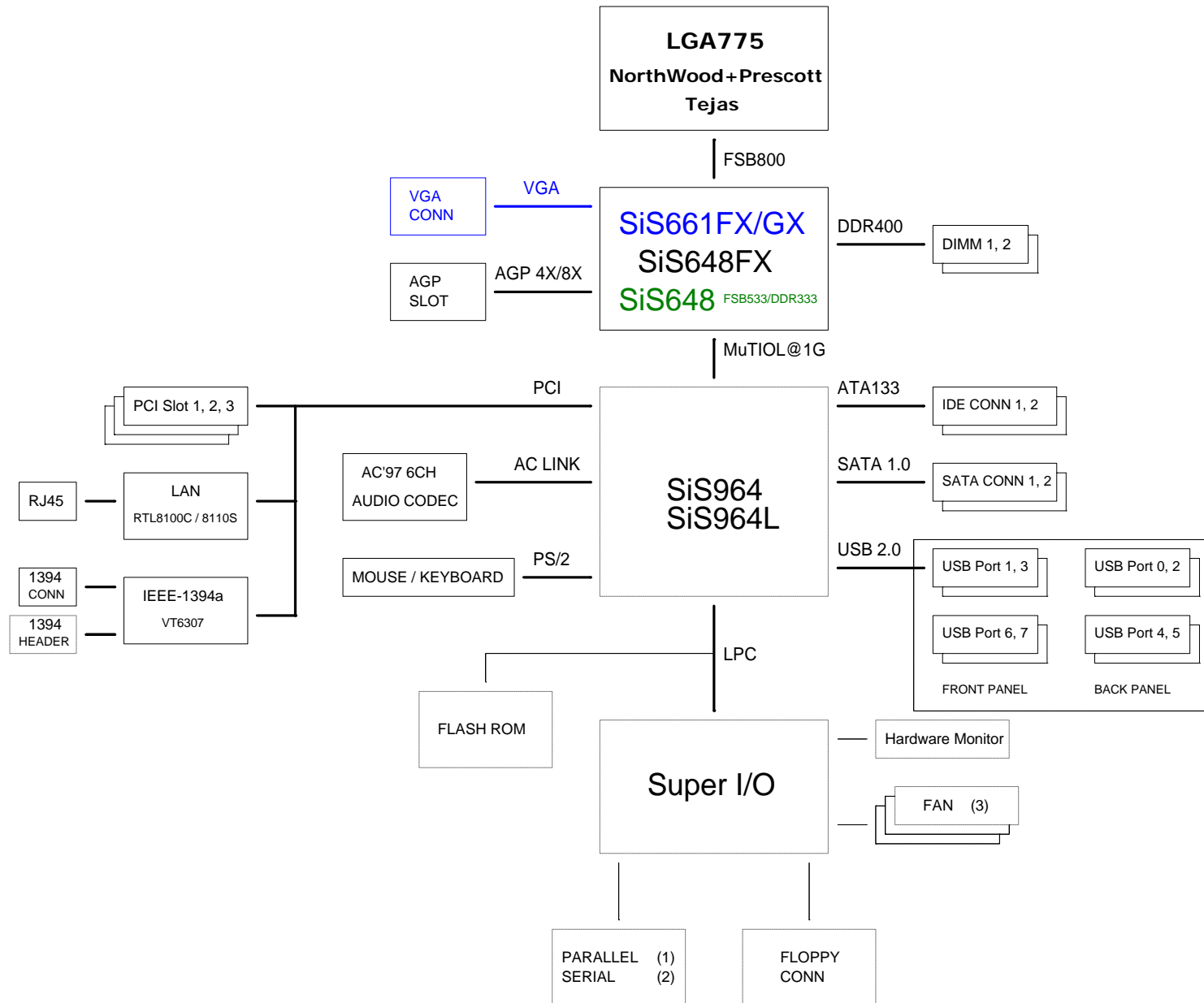

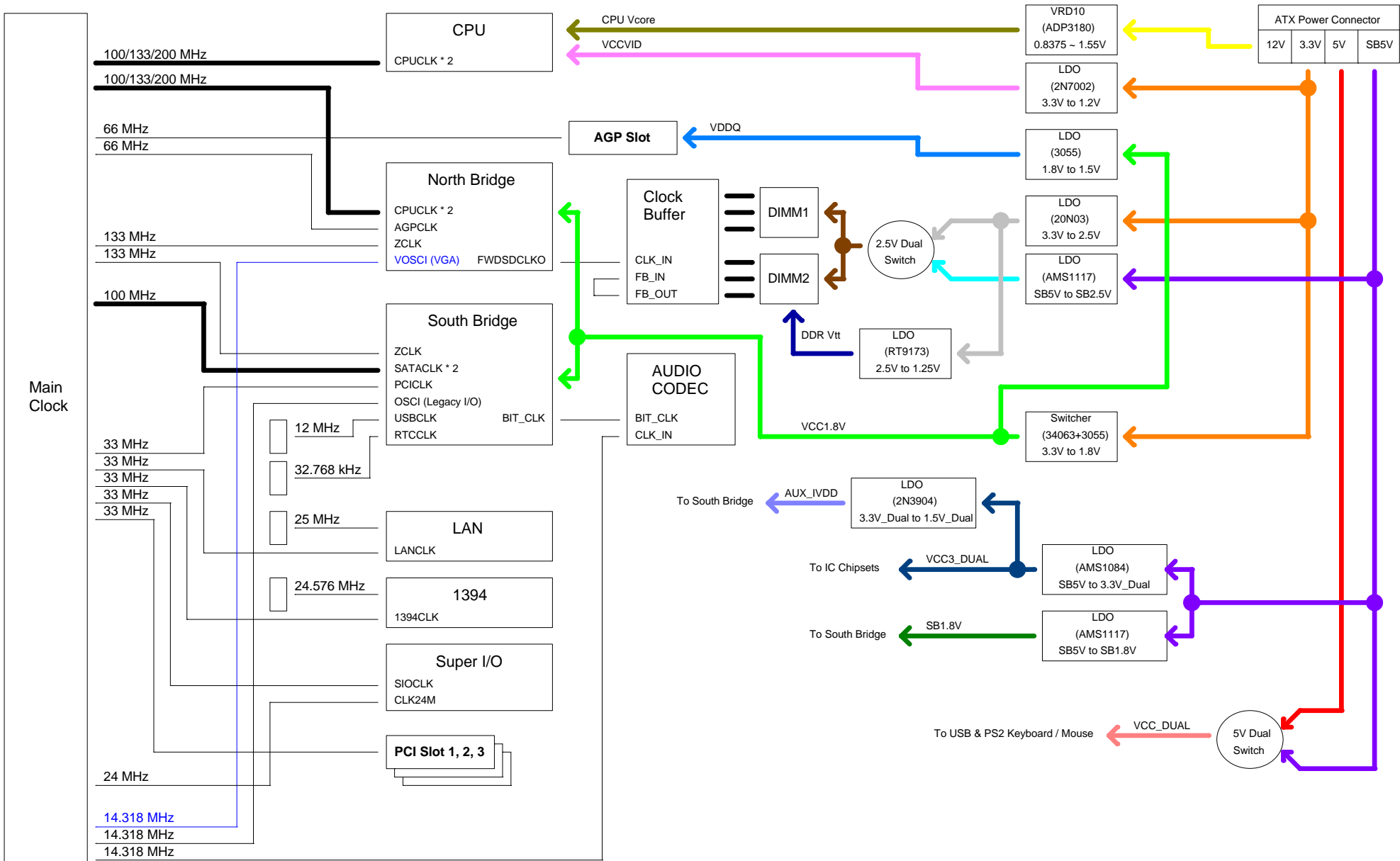

- 8 HBPM-[0..5] << HBPM-[0..5]
- 7 HRS-[0..2] << HRS-[0..2]
- 7 HD-[0..63] << HD-[0..63]
- 7 HA-[3..35] << HA-[3..35]
- 7 HREQ-[0..4] << HREQ-[0..4]
- 34 CPUVID[0..5] << CPUVID[0..5]

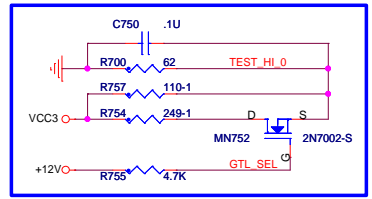
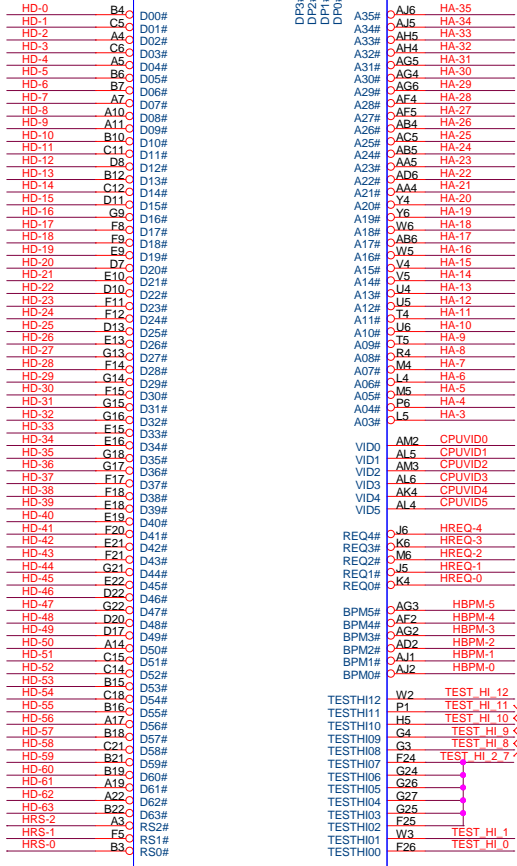

ADD C750, R754, R755, R757, MN752

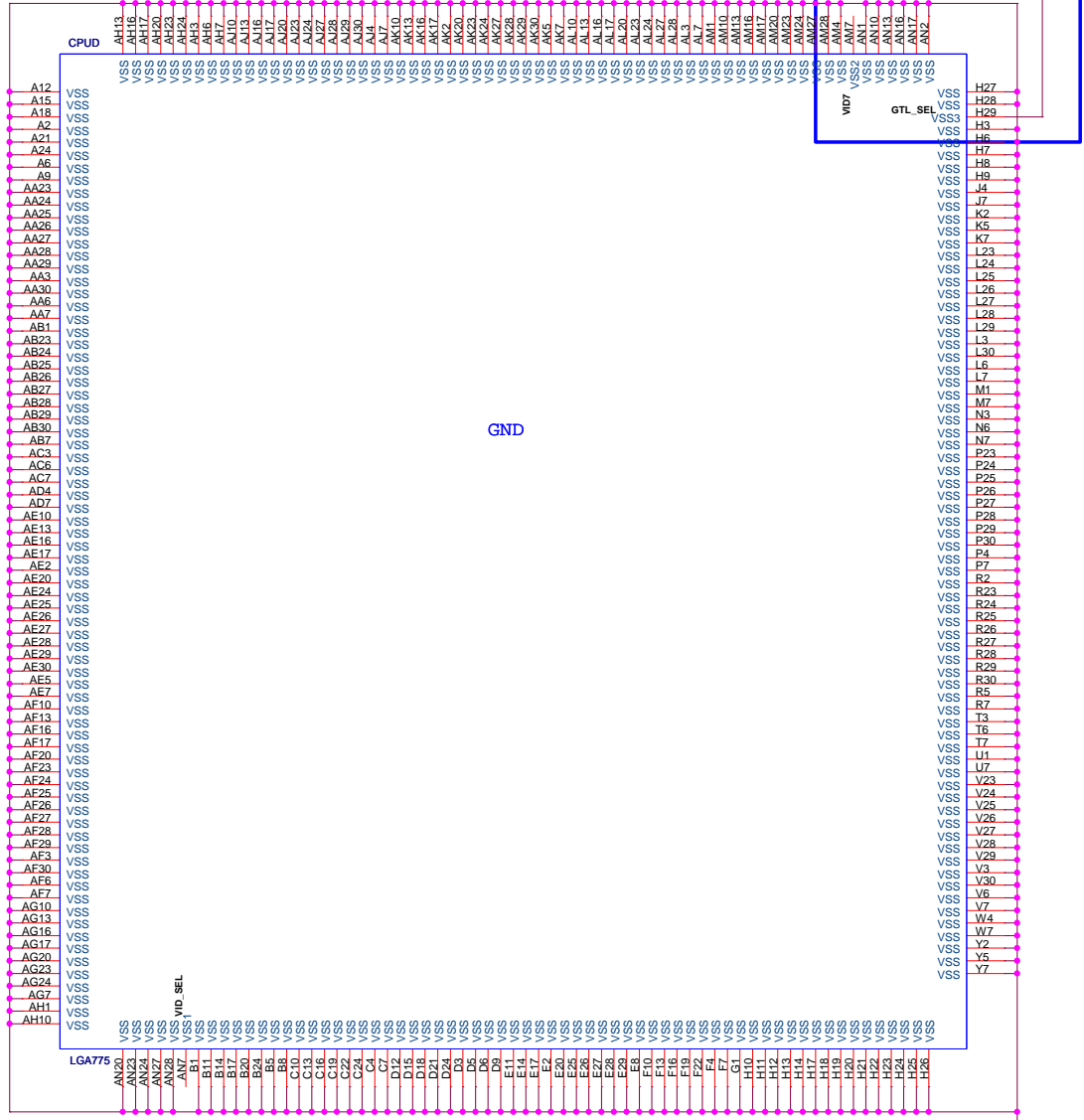
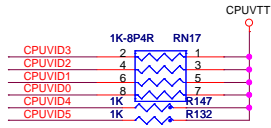

648/661FX/661GX-M7		
Title 648/661FX/661GX-M7	Document Number LGA775-1 (GND)	Rev 1.1
Size B	Date: Monday, March 14, 2005	Sheet 4 of 36

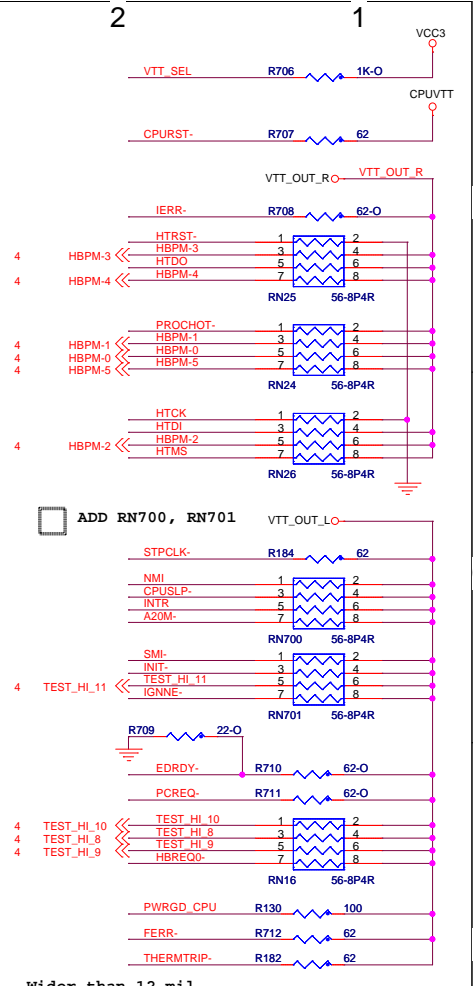
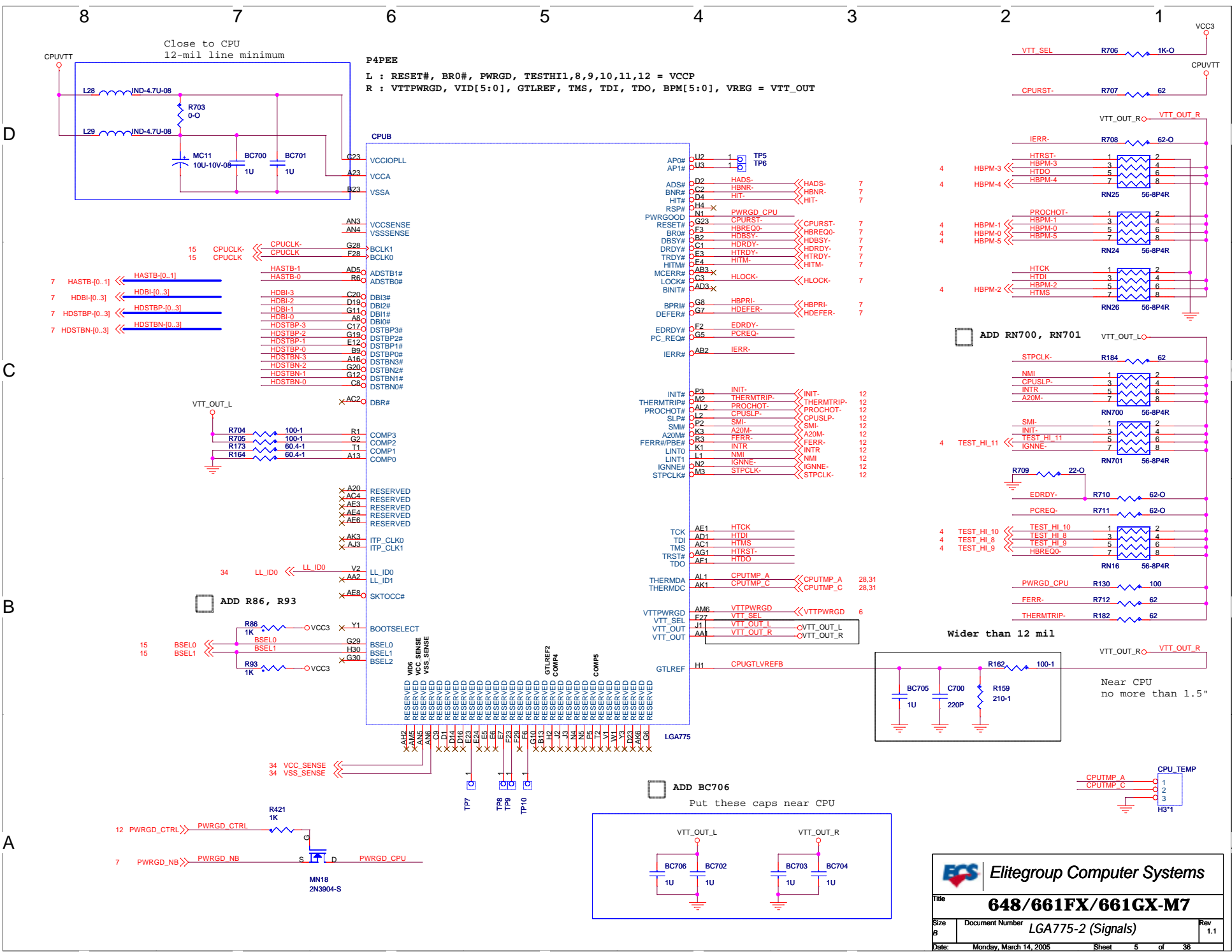

Elitegroup Computer Systems

Title **648/661FX/661GX-M7**

Size B Document Number **LGA775-2 (Signals)** Rev 1.1

Date: Monday, March 14, 2005 Sheet 5 of 36

8 7 6 5 4 3 2 1

Put these capacitors at processor TOP SIDE

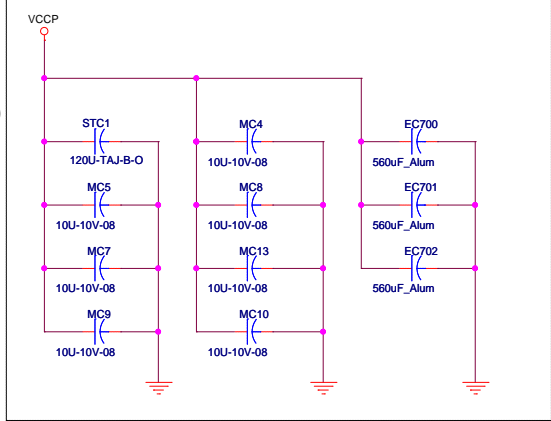

Put these capacitors at processor LEFT SIDE

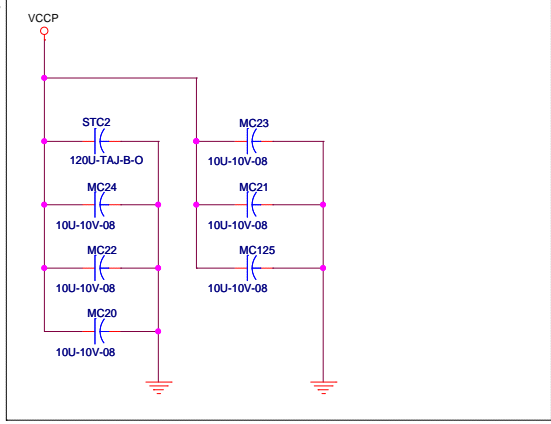

Put these capacitors INSIDE PROCESSOR CAVITY

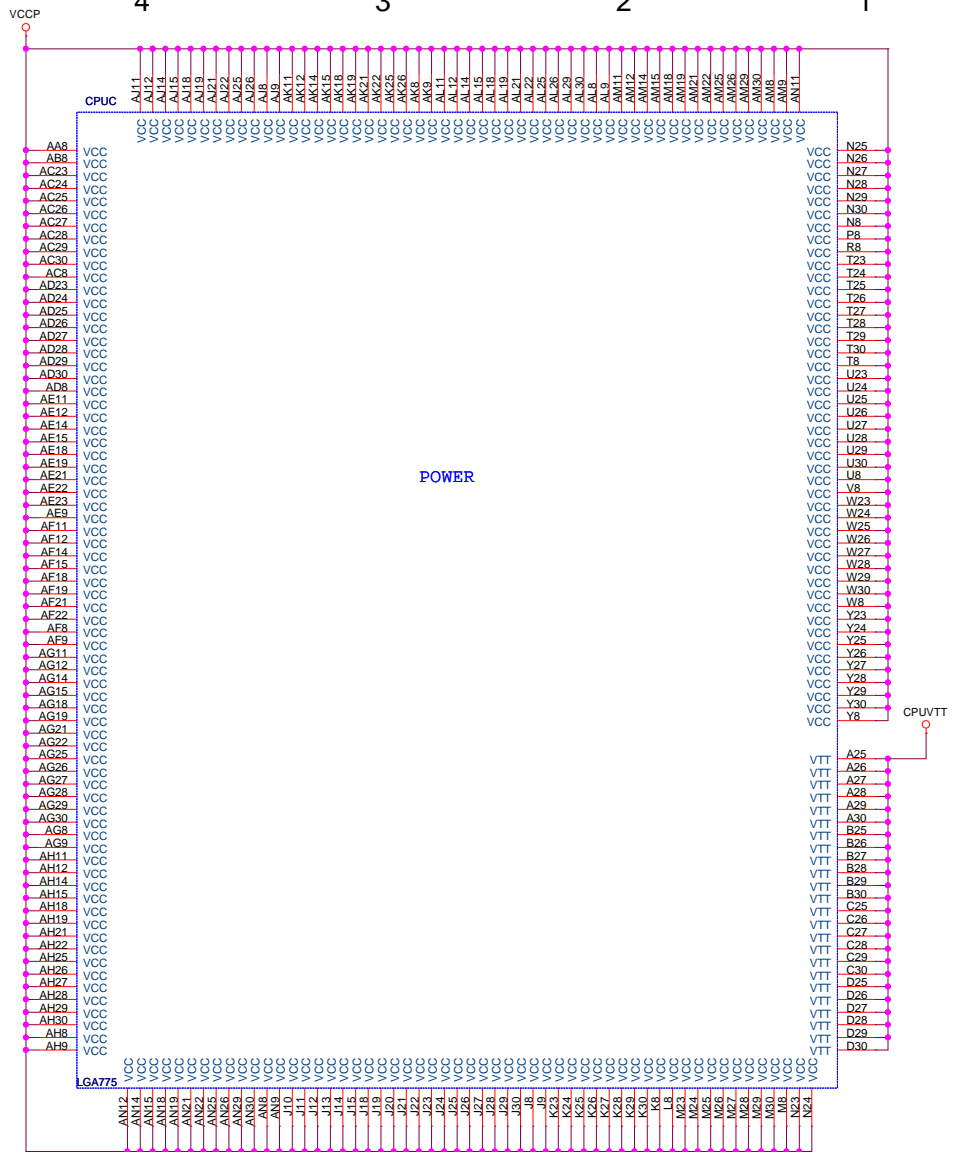
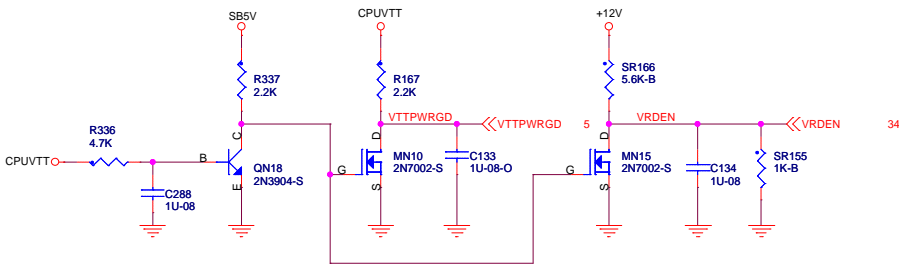
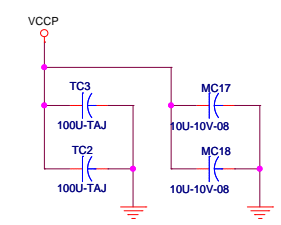

Elitegroup Computer Systems		
Title		
648/661FX/661GX-M7		
Size	Document Number	Rev
B	LGA755-3 (Power)	1.1
Date:	Monday, March 14, 2005	Sheet 6 of 36

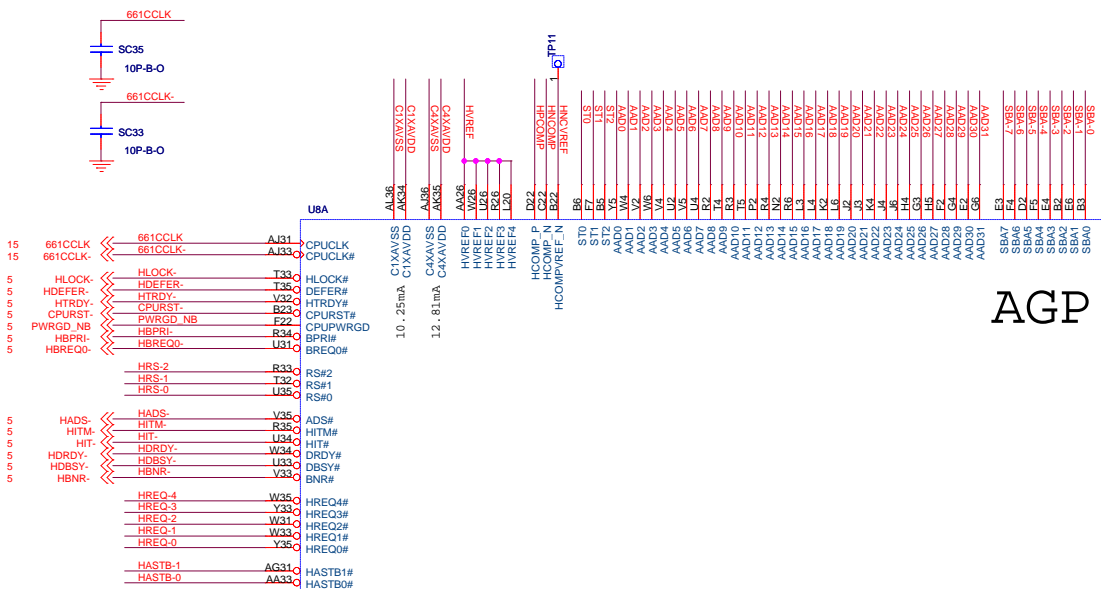

AGP

661FX-1

HOST

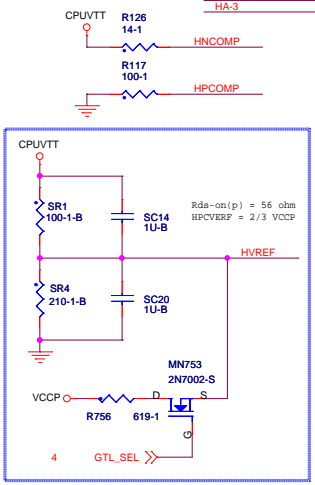
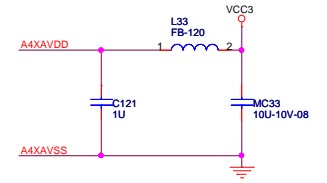
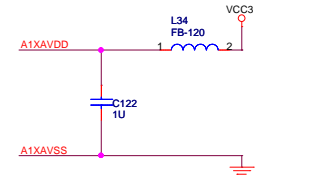
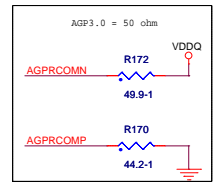
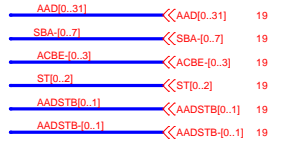
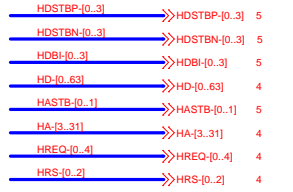

	R143	R133
648	20 1%	110 1%
648FX	14 1%	100 1%
661FX	14 1%	100 1%
661FXLV	14 1%	100 1%

	HNCVREF pin B22
648	Voltage divider
648FX	NC
661FX	
661FXLV	

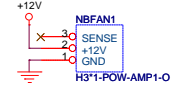
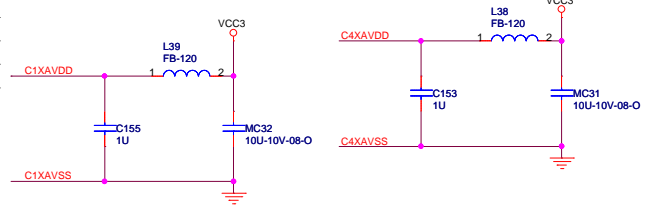

Elitegroup Computer Systems

Title: **648/661FX/661GX-M7**

Size: Custom Document Number: **SIS661FX-1 (Host/AGP)** Rev: 1.1

Date: Monday, March 14, 2005 Sheet 7 of 36

U8B

661FX-2

DMD0	AN35	MD0
DMD1	AP36	MD1
DMD2	AK33	MD2
DMD3	AN33	MD3
DMD4	AN34	MD4
DMD5	AK32	MD5
DMD6	AR34	MD6
DMD7	AN33	MD7
DMD0	AR36	DOM0
DDQS0	AP34	DQS0/CSB0#
DMD8	AM32	MD8
DMD9	AL31	MD9
DMD10	AR31	MD10
DMD11	AL30	MD11
DMD12	AN32	MD12
DMD13	AR33	MD13
DMD14	AN31	MD14
DMD15	AM31	MD15
DDQM1	AR32	DOM1
DMD16	AP30	DQS1/CSB1#
DMD17	AR30	MD16
DMD18	AN29	MD17
DMD19	AL27	MD18
DMD20	AN30	MD19
DMD21	AN28	MD20
DMD22	AN28	MD21
DMD23	AN28	MD22
DDQM2	AL29	DOM2
DMD24	AR28	DQS2/CSB2#
DMD25	AN25	MD24
DMD26	AR24	MD25
DMD27	AL24	MD26
DMD28	AL25	MD27
DMD29	AR26	MD28
DMD30	AM25	MD29
DMD31	AN24	MD30
DDQM3	AP24	DOM3
DDQS3	AR25	DQS3/CSB3#
DMD32	AN21	MD32
DMD33	AP20	MD33
DMD34	AN20	MD34
DMD35	AL18	MD35
DMD36	AM21	MD36
DMD37	AR21	MD37
DMD38	AL19	MD38
DMD39	AM19	MD39
DDQM4	AL20	DOM4
DDQS4	AR20	DQS4/CSB4#
DMD40	AL15	MD40
DMD41	AL14	MD41
DMD42	AN15	MD42
DMD43	AR15	MD43
DMD44	AN16	MD44
DMD45	AM15	MD45
DMD46	AL14	MD46
DMD47	AL13	MD47
DDQM5	AP16	DOM5
DDQS5	AR16	DQS5/CSB5#
DMD48	AM13	MD48
DMD49	AL12	MD49
DMD50	AL11	MD50
DMD51	AR12	MD51
DMD52	AP14	MD52
DMD53	AR14	MD53
DMD54	AN13	MD54
DMD55	AP12	MD55
DDQM6	AN12	DOM6
DDQS6	AR13	DQS6/CSB6#
DMD56	AL10	MD56
DMD57	AR11	MD57
DMD58	AM5	MD58
DMD59	AR9	MD59
DMD60	AM11	MD60
DMD61	AN11	MD61
DMD62	AP10	MD62
DMD63	AN9	MD63
DDQM7	AN10	DOM7
DDQS7	AR10	DQS7/CSB7#

MA0	AR23	DMA0
MA1	AN23	DMA1
MA2	AN22	DMA2
MA3	AM23	DMA3
MA4	AL26	DMA4
MA5	AN26	DMA5
MA6	AN27	DMA6
MA7	AR27	DMA7
MA8	AR28	DMA8
MA9	AP22	DMA9
MA10	AN18	DMA10
MA11	AR22	DMA11
MA12	AP29	DMA12
MA13	AM27	DMA13
MA14	AM27	DMA14
MA15	AT14	

SRAS#	JAL17	DRAS-	DRAS-	17,18
SCAS#	AR19	DCAS-	DCAS-	17,18
SWE#	AN19	DWE-	DWE-	17,18

CS0#	AM17	DCS-0
CS1#	AL16	DCS-1
CS2#	AN17	DCS-2
CS3#	AR17	DCS-3
CS4#	AP18	
CS5#	AR18	

CKE0	AP4	CKE0
CKE1	AT3	CKE1
CKE2	AR3	CKE2
CKE3	AP3	CKE3
CKE4	AR2	
CKE5	AN4	

S3AUXSW# <<S3AUXSW- 33

FWSDCLKO AL21 FWSDCLKO <<FWSDCLKO 16

DRAMTEST AL22 SC39 10P-B-O

10.15mA DLLAVDD AL35 DLLAVDD

DLLAVSS AL34 DLLAVSS

24.86mA DDRAVDD AM35 DDRAVDD

DDRAVSS AN36 DDRAVSS

DDRREFB AF16 DDRREFB

DDRREFA AF23 DDRREFB

TRAP2 AP1

DDRCOMP_P AR8 DDRCOMP

DDRCOMP_N AP8 DDRCOMIN

SIS661FX

DMD[0..63]	<<DMD[0..63]	17,18
DDQM[0..7]	<<DDQM[0..7]	17,18
DDQS[0..7]	<<DDQS[0..7]	17,18
DMA[0..14]	<<DMA[0..14]	17,18
DCS[0..3]	<<DCS[0..3]	17,18
CKE[0..3]	<<CKE[0..3]	17

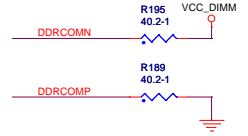
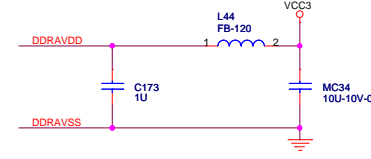
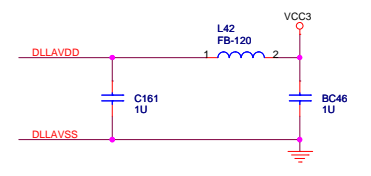
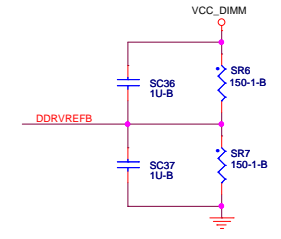
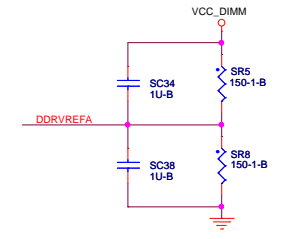

ECS Elitegroup Computer Systems

Title: **648/661FX/661GX-M7**

Size: Custom Document Number: **SIS661FX-2 (Memory)** Rev: 1.1

Date: Monday, March 14, 2005 Sheet: 8 of 36

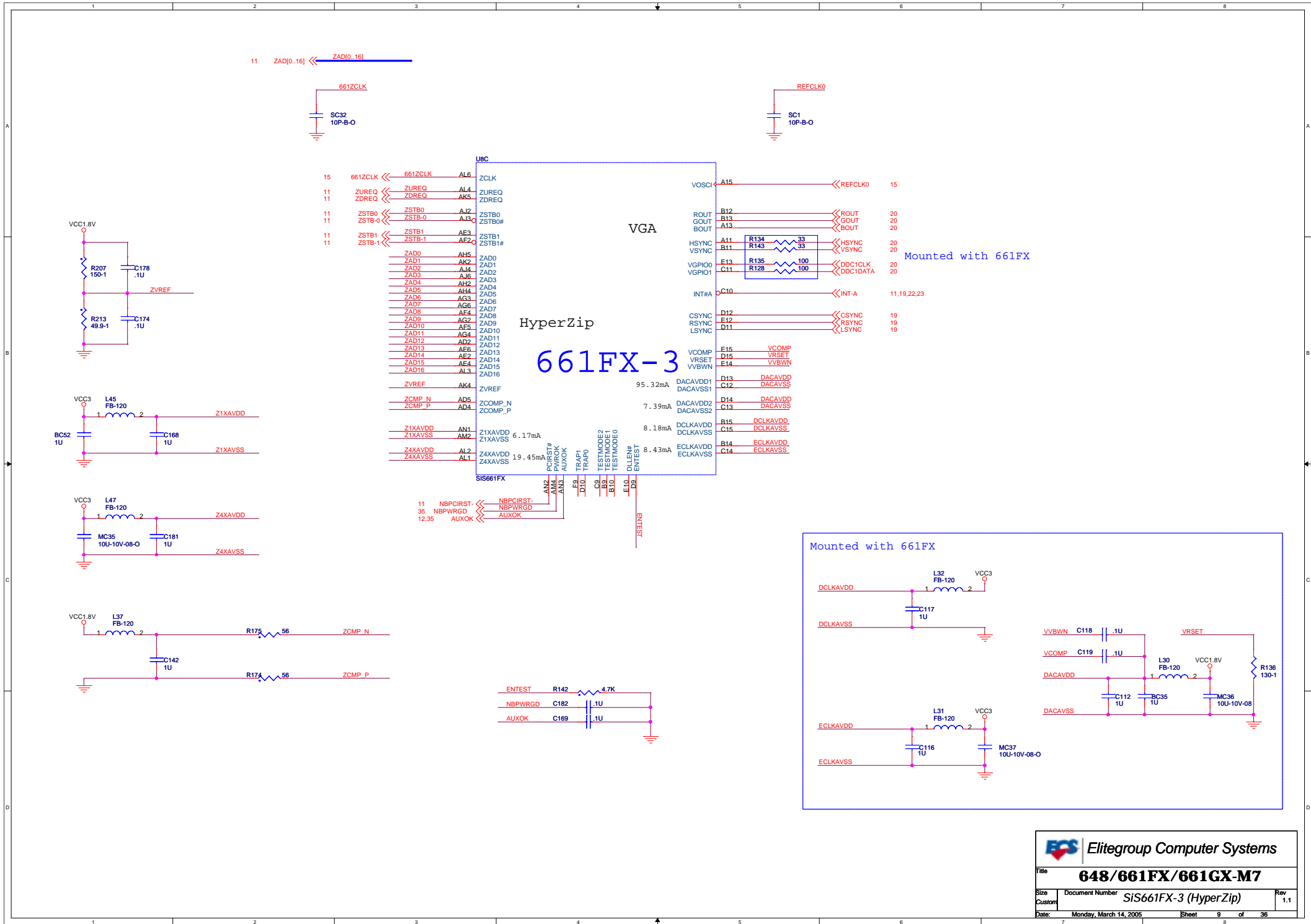

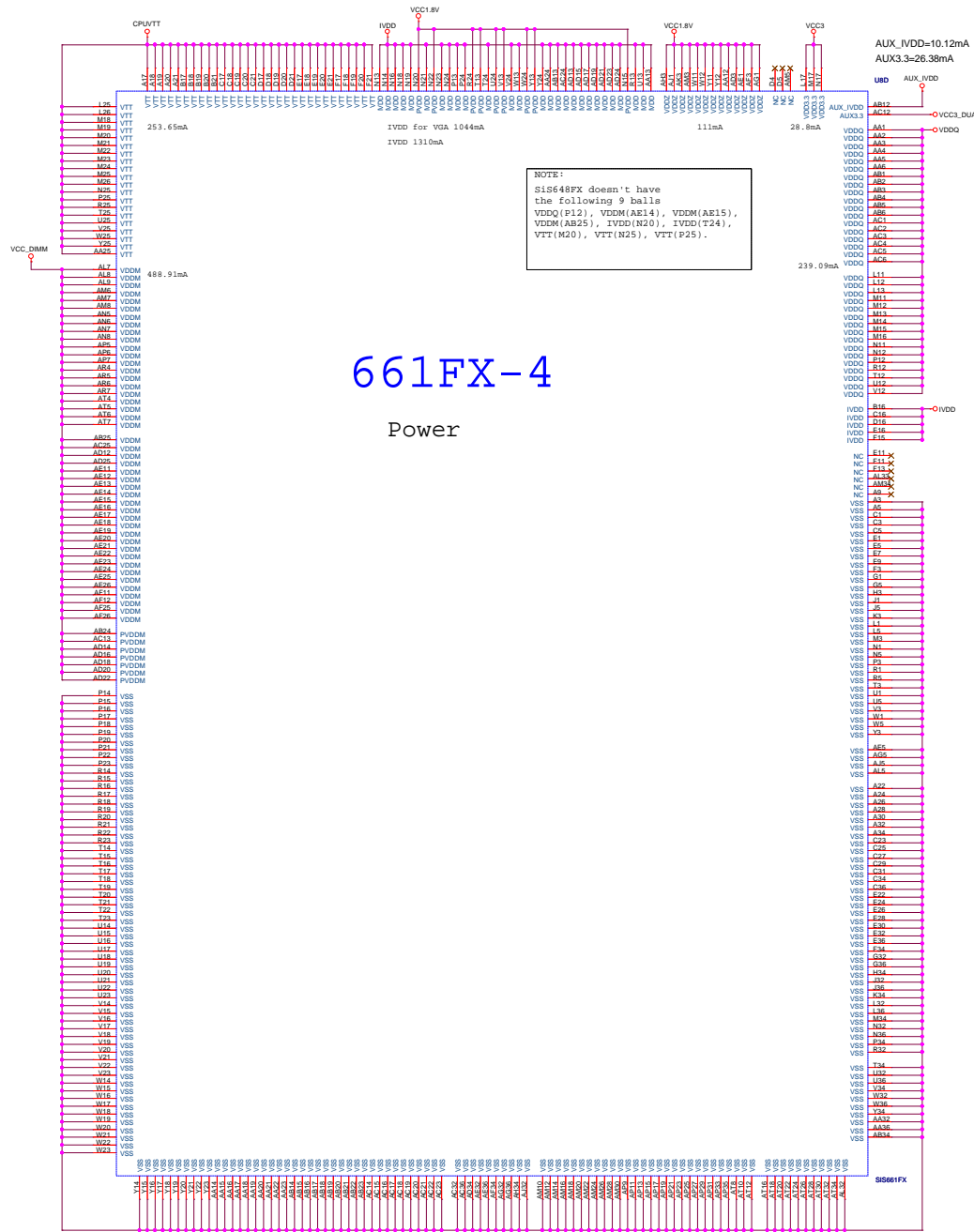

661FX-4

Power

NOTE:
SiS648FX doesn't have the following 9 balls
VDDQ(P12), VDDQ(AE14), VDDQ(AE15),
VDDQ(AB25), VDDQ(N20), VDDQ(T24),
VTT(M20), VTT(N25), VTT(P25).

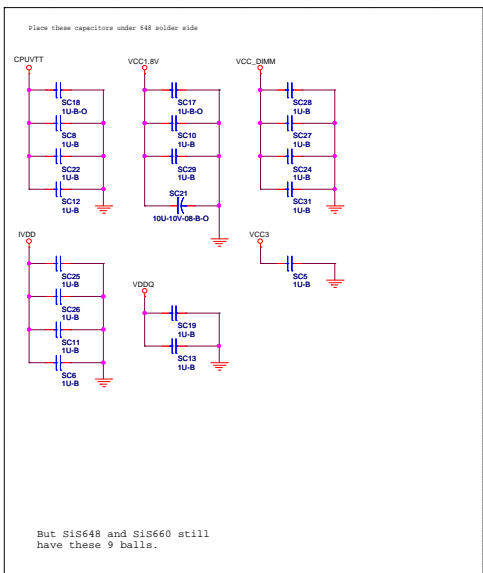
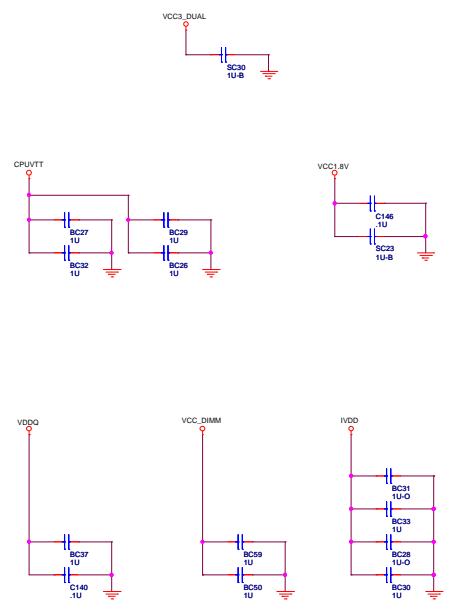

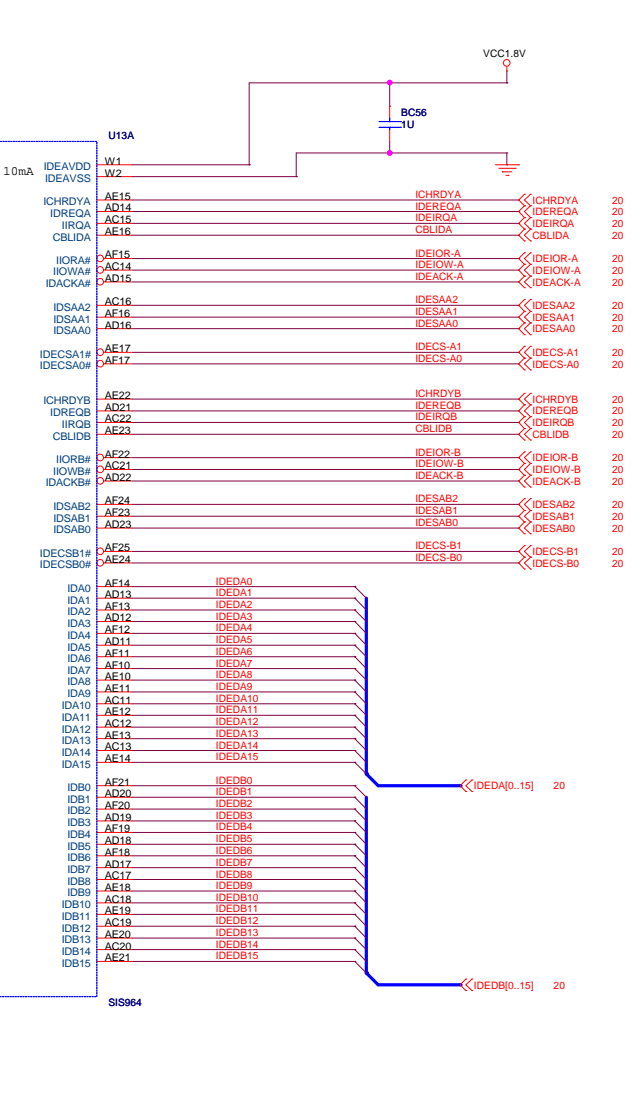
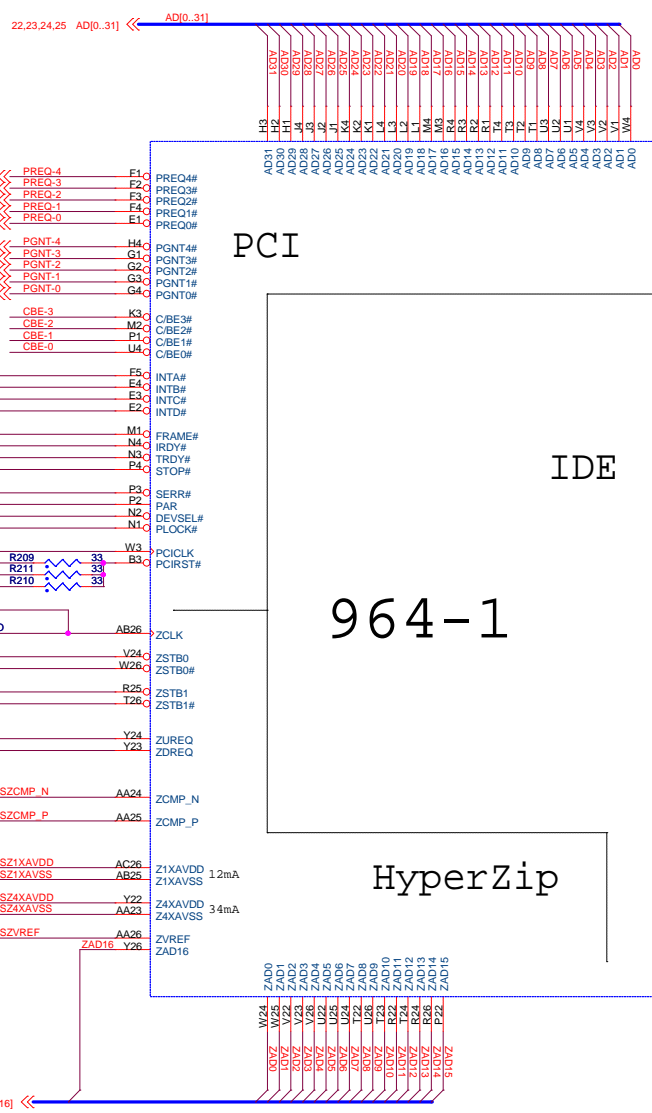
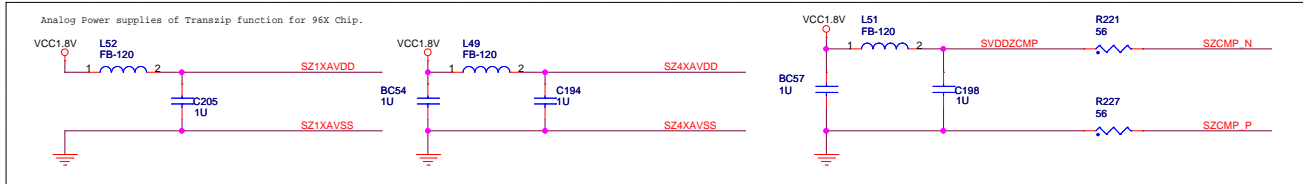
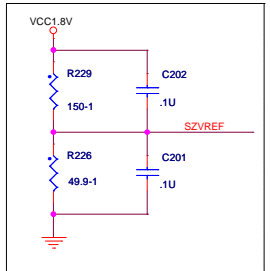
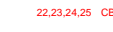
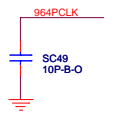
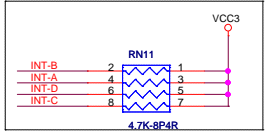

Programmable on-die pull-high strength for CPU_S:
(Infinite, 150, 110, 56 Ohm)

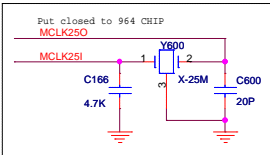
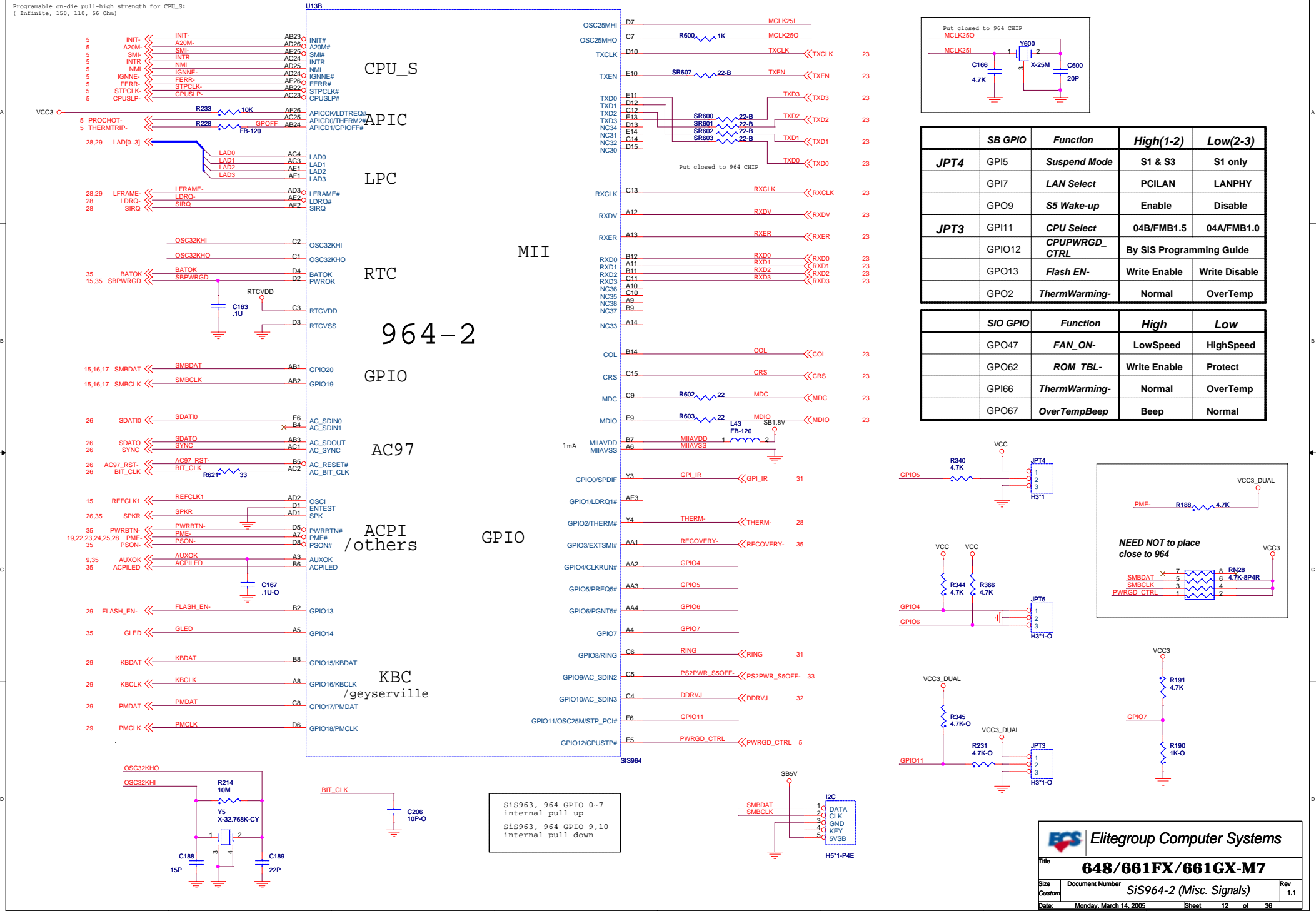

	SB GPIO	Function	High(1-2)	Low(2-3)
JPT4	GPIO5	Suspend Mode	S1 & S3	S1 only
	GPIO7	LAN Select	PCILAN	LANPHY
	GPO9	S5 Wake-up	Enable	Disable
JPT3	GPIO11	CPU Select	04B/FMB1.5	04A/FMB1.0
	GPIO12	CPUPWRGD_CTRL	By SiS Programming Guide	
	GPO13	Flash EN-	Write Enable	Write Disable
	GPO2	ThermWarming-	Normal	OverTemp

	SIO GPIO	Function	High	Low
	GPO47	FAN_ON-	LowSpeed	HighSpeed
	GPO62	ROM_TBL-	Write Enable	Protect
	GPIO66	ThermWarming-	Normal	OverTemp
	GPO67	OverTempBeep	Beep	Normal

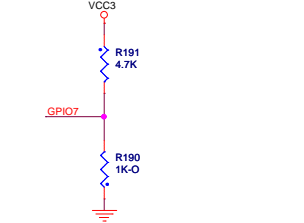
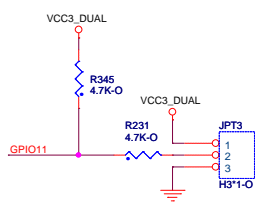
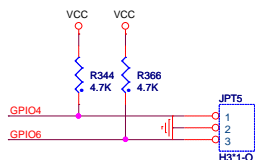
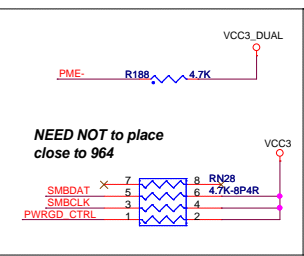
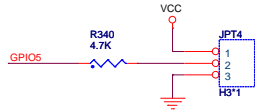

SiS963, 964 GPIO 0-7
internal pull up
SiS963, 964 GPIO 9,10
internal pull down

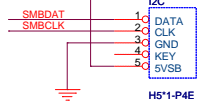

Elitegroup Computer Systems

Title: **648/661FX/661GX-M7**

Size: Custom Document Number: **SiS964-2 (Misc. Signals)** Rev: 1.1

Date: Monday, March 14, 2005 Sheet 12 of 36

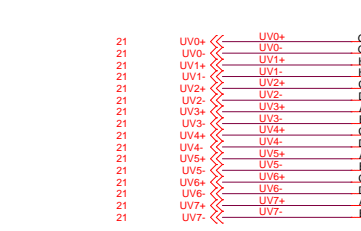
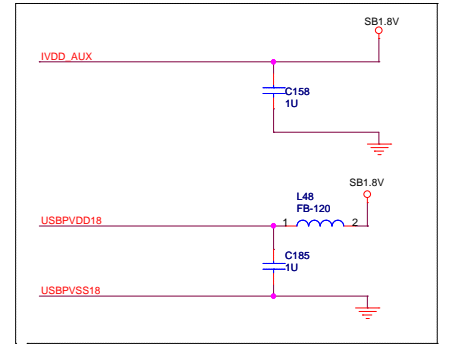
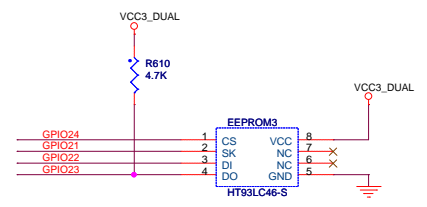
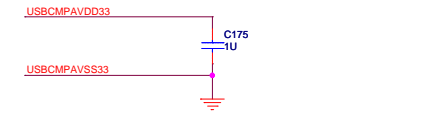
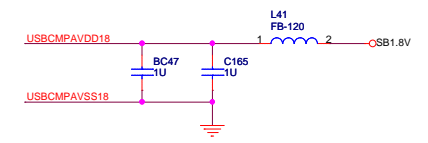
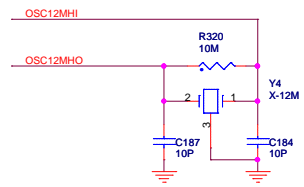
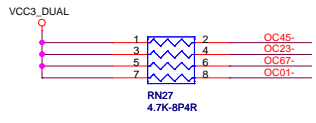

USB
964-3
330mA

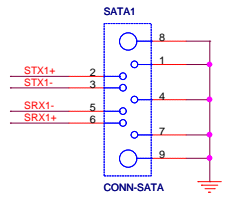
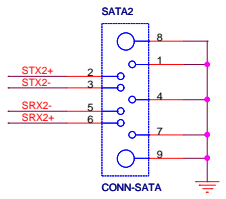
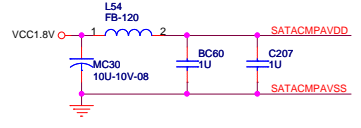
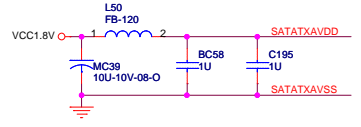
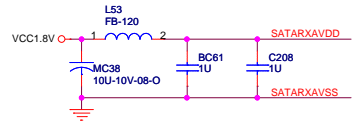
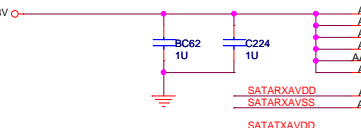
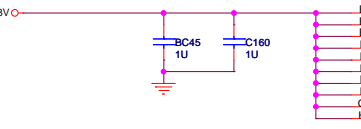
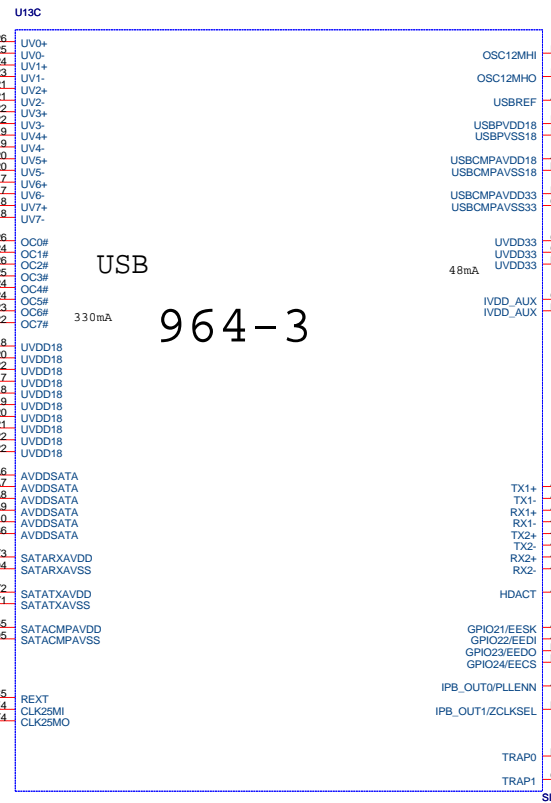

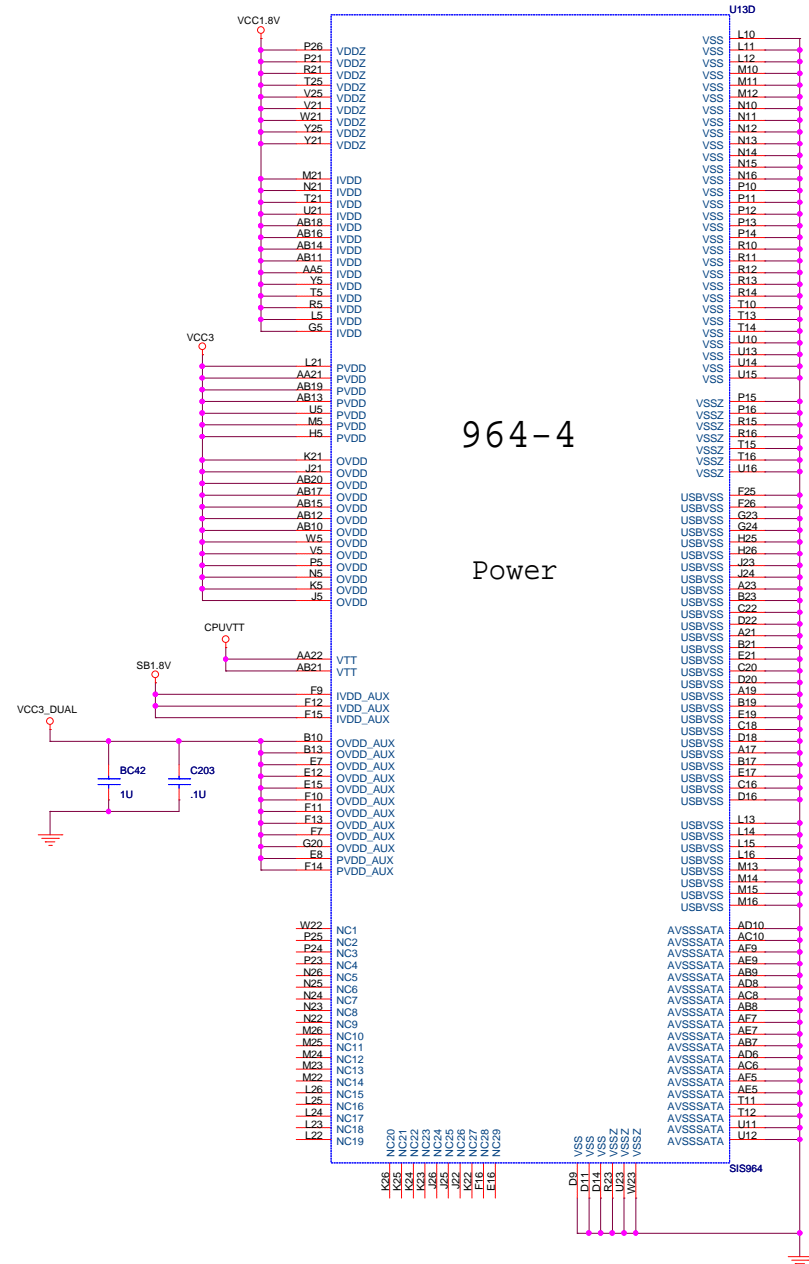
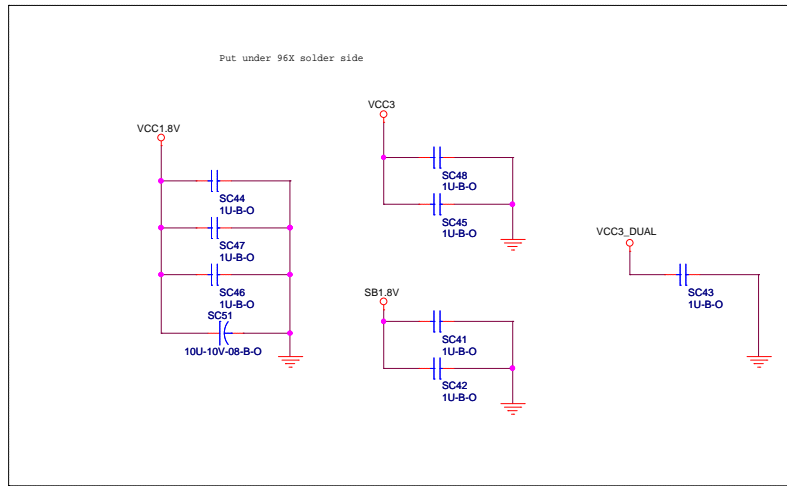
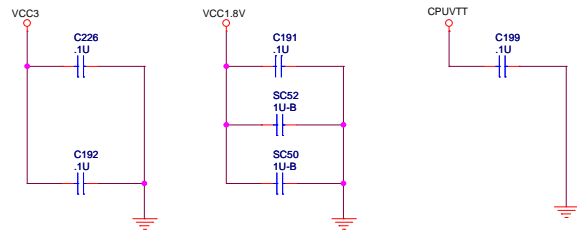

964-4
Power

Main Clock Generator

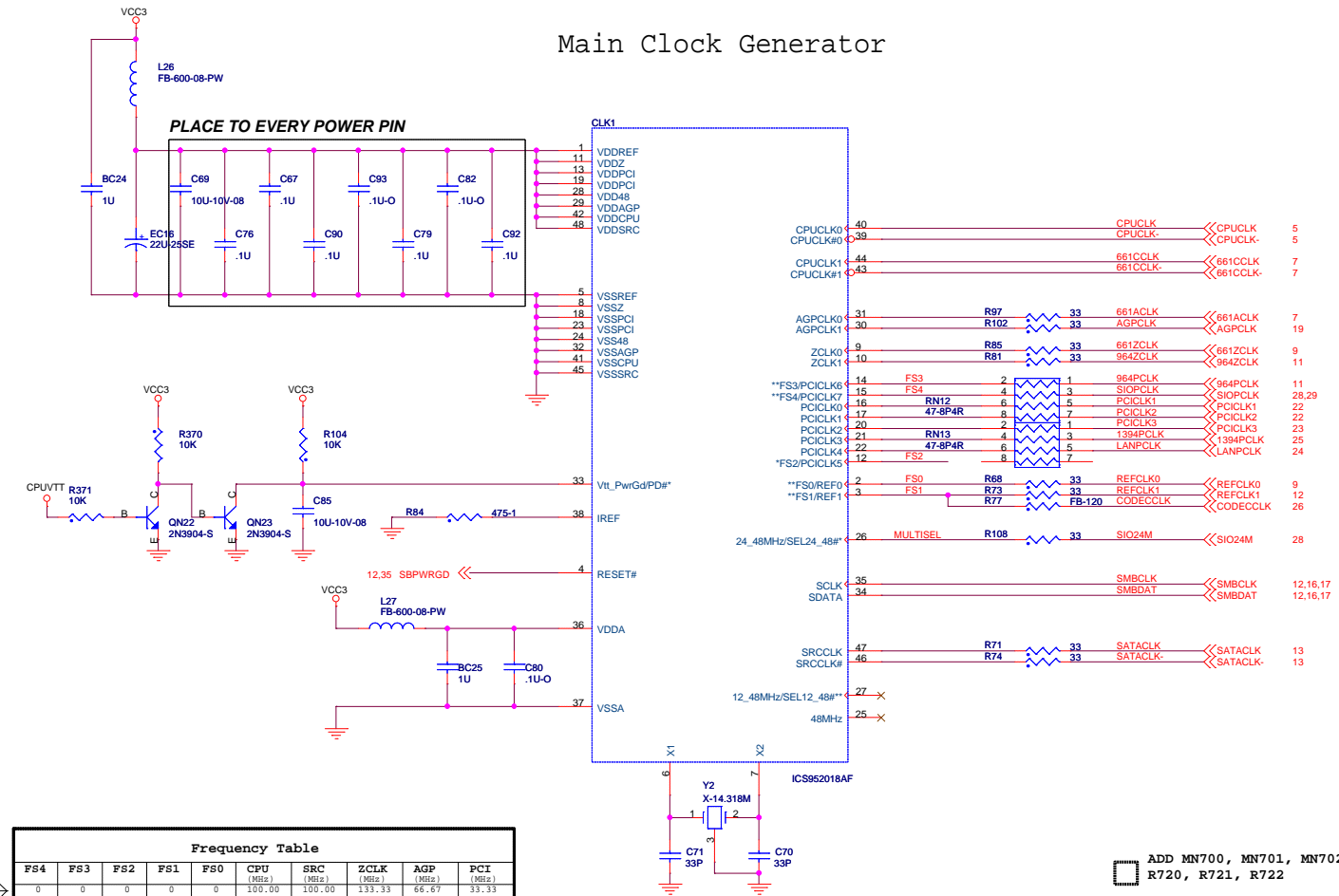

By-Pass Capacitors

Place near to the Clock Outputs

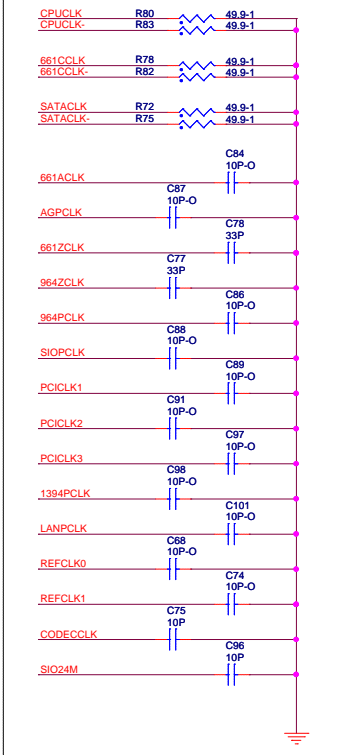

Frequency Table										
	FS4	FS3	FS2	FS1	FS0	CPU (MHz)	SRC (MHz)	ZCLK (MHz)	AGP (MHz)	PCI (MHz)
FSB400	0	0	0	0	0	100.00	100.00	133.33	66.67	33.33
FSB400	0	0	0	1	0	100.99	100.99	134.65	67.33	33.66
FSB400	0	0	1	0	0	103.00	103.00	137.33	68.67	34.33
FSB400	0	0	1	1	0	100.00	100.00	133.33	66.67	33.33
FSB400	0	1	0	0	0	133.33	100.00	133.33	66.66	33.33
FSB400	0	1	0	1	0	134.65	100.99	134.65	67.32	33.66
FSB400	0	1	1	0	0	137.33	103.00	137.33	68.66	34.33
FSB400	0	1	1	1	0	133.33	100.00	133.33	66.67	33.33
FSB800	0	1	0	0	0	200.00	100.00	133.33	66.67	33.33
FSB800	0	1	0	1	0	201.98	100.99	134.65	67.33	33.66
FSB800	0	1	1	0	0	206.00	103.00	137.33	68.67	34.33
FSB800	0	1	1	1	0	200.00	100.00	133.33	66.67	33.33
FSB800	0	1	1	0	1	214.66	107.00	142.67	71.33	35.67
FSB800	0	1	1	1	0	218.00	109.00	145.33	72.67	36.33
FSB800	0	1	1	1	1	220.00	110.00	146.67	73.33	36.67
FSB800	0	1	1	1	0	140.00	105.00	140.00	70.00	35.00
FSB800	0	1	1	1	1	142.66	107.00	142.67	71.33	35.67
FSB800	0	1	1	1	0	145.33	109.00	145.33	72.66	36.33
FSB800	0	1	1	1	1	146.66	110.00	146.66	73.33	36.67
FSB800	1	1	0	0	0	210.00	105.00	140.00	70.00	35.00
FSB800	1	1	0	1	0	214.00	107.00	142.67	71.33	35.67
FSB800	1	1	0	1	1	218.00	109.00	145.33	72.67	36.33
FSB800	1	1	1	0	0	220.00	110.00	146.67	73.33	36.67
FSB800	1	1	1	1	0	266.66	100.00	133.33	66.67	33.33
FSB800	1	1	1	1	0	269.33	101.00	134.67	67.33	33.67
FSB800	1	1	1	1	1	274.66	103.00	137.33	68.67	34.33
FSB800	1	1	1	1	1	266.66	100.00	133.33	66.67	33.33

Frequency Table										
	FS4	FS3	FS2	FS1	FS0	CPU (MHz)	SRC (MHz)	ZCLK (MHz)	AGP (MHz)	PCI (MHz)
FSB1066	1	0	0	0	0	105.00	105.00	140.00	70.00	35.00
FSB1066	1	0	0	0	1	107.00	107.00	142.67	71.33	35.67
FSB1066	1	0	0	1	0	109.00	109.00	145.33	72.67	36.33
FSB1066	1	0	0	1	1	110.00	110.00	146.67	73.33	36.67
FSB1066	1	0	1	0	0	140.00	105.00	140.00	70.00	35.00
FSB1066	1	0	1	0	1	142.66	107.00	142.67	71.33	35.67
FSB1066	1	0	1	1	0	145.33	109.00	145.33	72.66	36.33
FSB1066	1	0	1	1	1	146.66	110.00	146.66	73.33	36.67
FSB1066	1	1	0	0	0	210.00	105.00	140.00	70.00	35.00
FSB1066	1	1	0	0	1	214.00	107.00	142.67	71.33	35.67
FSB1066	1	1	0	1	0	218.00	109.00	145.33	72.67	36.33
FSB1066	1	1	0	1	1	220.00	110.00	146.67	73.33	36.67
FSB1066	1	1	1	0	0	266.66	100.00	133.33	66.67	33.33
FSB1066	1	1	1	0	1	269.33	101.00	134.67	67.33	33.67
FSB1066	1	1	1	1	0	274.66	103.00	137.33	68.67	34.33
FSB1066	1	1	1	1	1	266.66	100.00	133.33	66.67	33.33

Frequency Selection

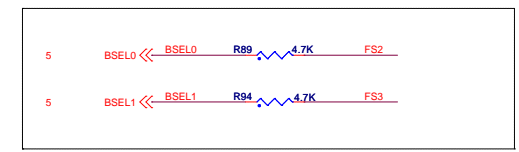

Clock Generator Table	FS4	FS3	FS2	FS1	FS0
	Hardware Trapping	Low	Low	BSEL2	BSEL1
CPU=100 (BSEL[2:0]=101)					
CPU=133 (BSEL[2:0]=001)	0	0	1	0	0
CPU=166 (BSEL[2:0]=011)	0	1	1	0	0
CPU=200 (BSEL[2:0]=010)	0	1	0	0	0
CPU=266 (BSEL[2:0]=000)	1	1	1	0	0

ADD MN700, MN701, MN702, QN700, QN701, R720, R721, R722

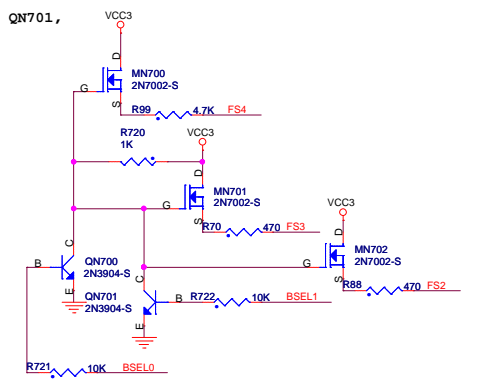

Elitegroup Computer Systems

Title: **648/661FX/661GX-M7**

Size: Custom Document Number: Main Clock Rev: 1.1

Date: Monday, March 14, 2005 Sheet: 15 of 36

Clock Buffer (DDR)

(5 OPTIONS)
 1: (ICS) ICS93716
 2: (Winbond)
 3: (ICWorks)
 4: (IMI)
 5: (AMI)

By-Pass Capacitors
 Place near to the Clock Buffer

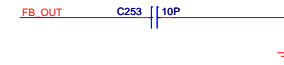
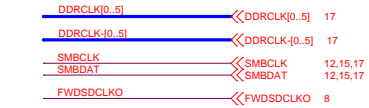
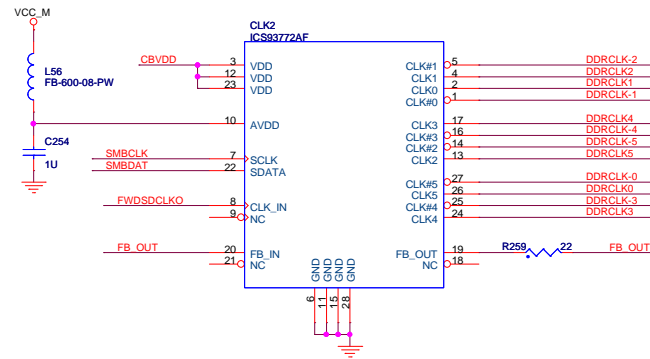
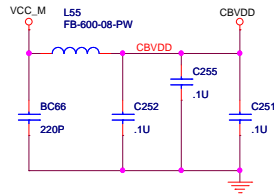

NOTE:
VDDID IS A TRAP ON THE DIMM
MODULE TO INDICATE:

VDDID	REQUIRED POWER
OPEN	VDD=VDDQ
GND	VDD1=VDDQ

MEMORY MIX TABLE:

SDR	DDR
CS0	CS0
CS1	CS1
CS2	CS2
CS3	CS3
CS4	CS4
CS5	CS5
CSB0	DQS0
CSB1	DQS1
CSB2	DQS2
CSB3	DQS3
CSB4	DQS4
CSB5	DQS5
CSB6	DQS6
CSB7	DQS7

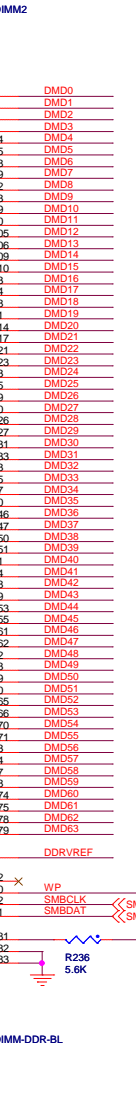
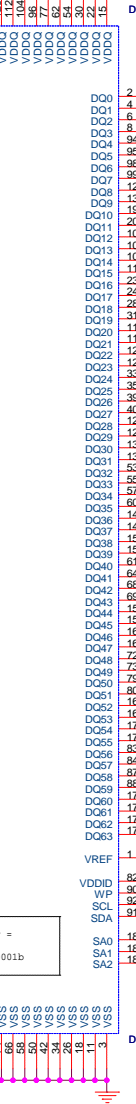
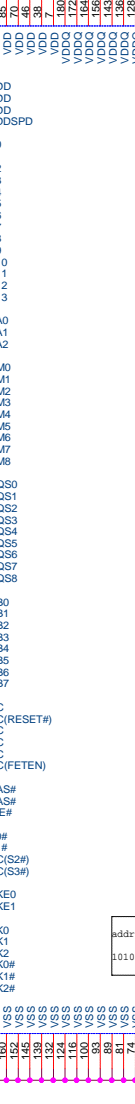
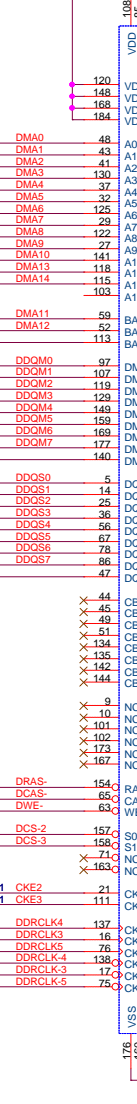
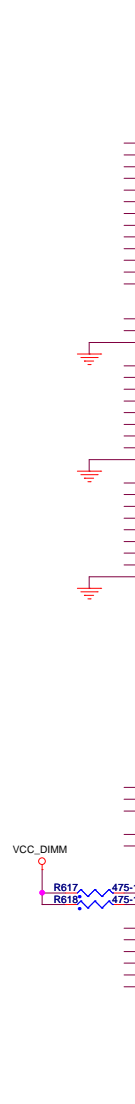
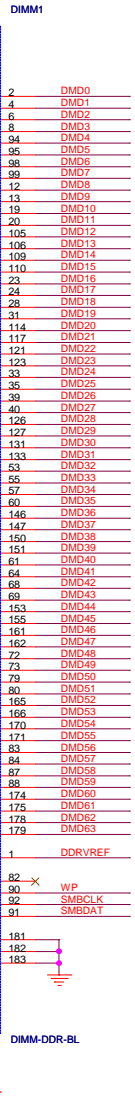
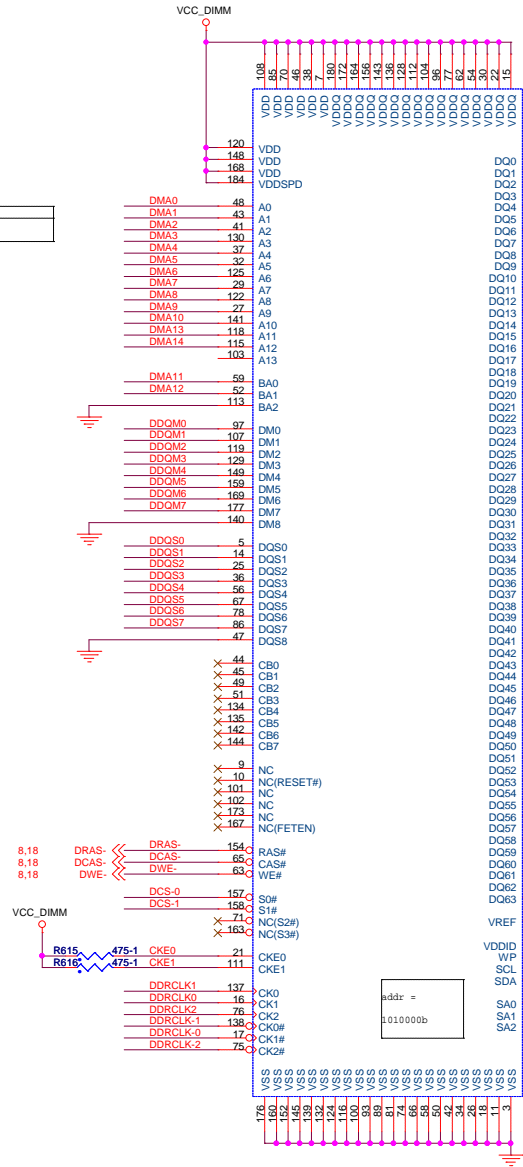

- DMD[0..63] << DMD[0..63] 8,18
- DMA[0..14] << DMA[0..14] 8,18
- DDQM[0..7] << DDQM[0..7] 8,18
- DDQS[0..7] << DDQS[0..7] 8,18
- DCS[0..3] << DCS[0..3] 8,18
- CKE[0..3] << CKE[0..3] 8
- DDRCLK[0..5] << DDRCLK[0..5] 16
- DDRCLK[0..5] << DDRCLK[0..5] 16

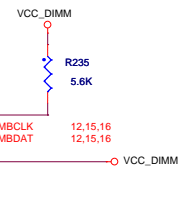
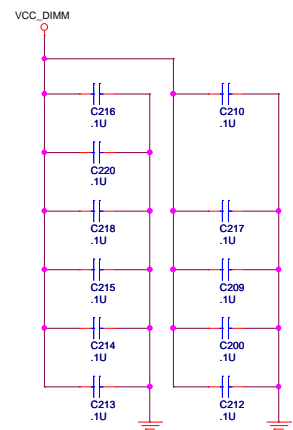
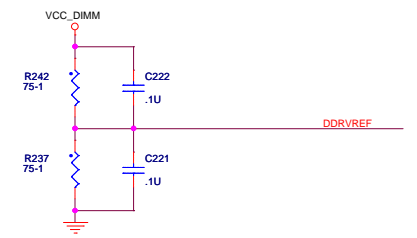

Elitegroup Computer Systems

Title: **648/661FX/661GX-M7**

Size: Document Number **DI MM 1,2** Rev: 1.1

Custom: **Monday, March 14, 2005** Sheet 17 of 36

SSTL-2 Termination Resistors

	SDR	R#	DDR	R#	Rtc
MD/DQM/(DQS)	LV-CMOS	0/10/-	SSTL-2	10	33
MA/Control	LV-CMOS	10	SSTL-2	0	33
CS	LV-CMOS	0	SSTL-2	0	47
CE#	DD 3.3V		DD 2.5V		

- ◀◀DMD[0..63] 8.17
- ◀◀DMA[0..14] 8.17
- ◀◀DDQM[0..7] 8.17
- ◀◀DDQS[0..7] 8.17
- ◀◀DCS[0..3] 8.17

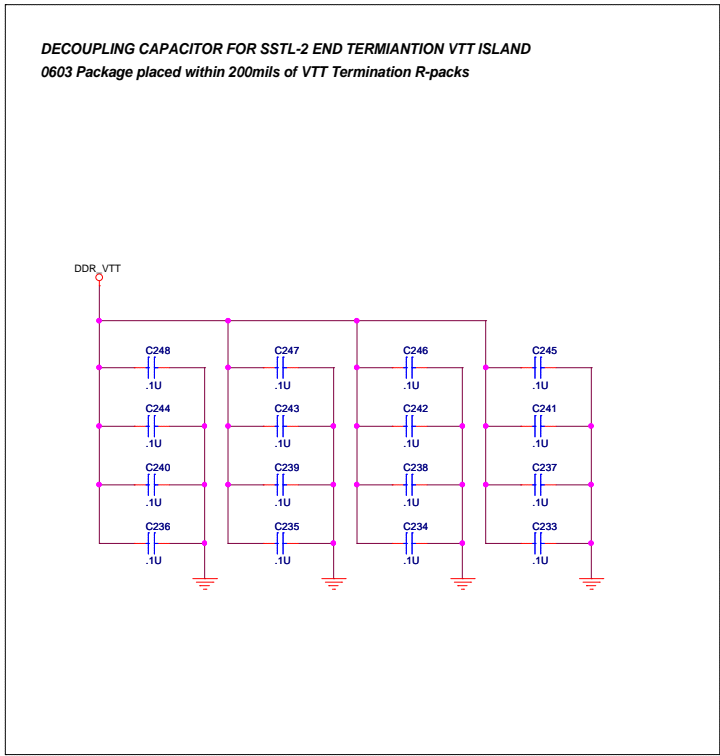
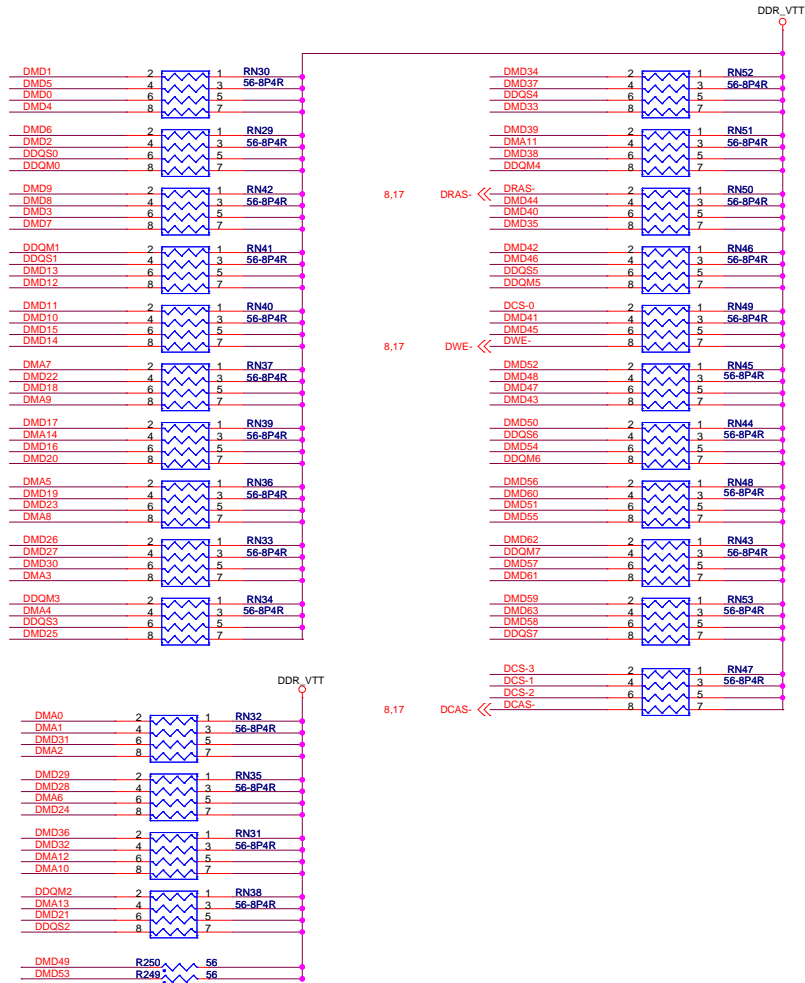

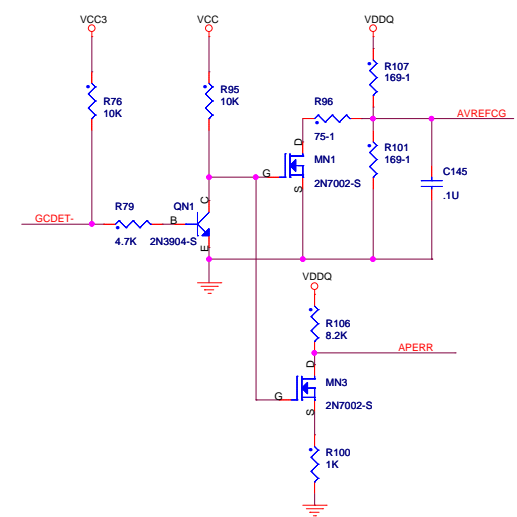
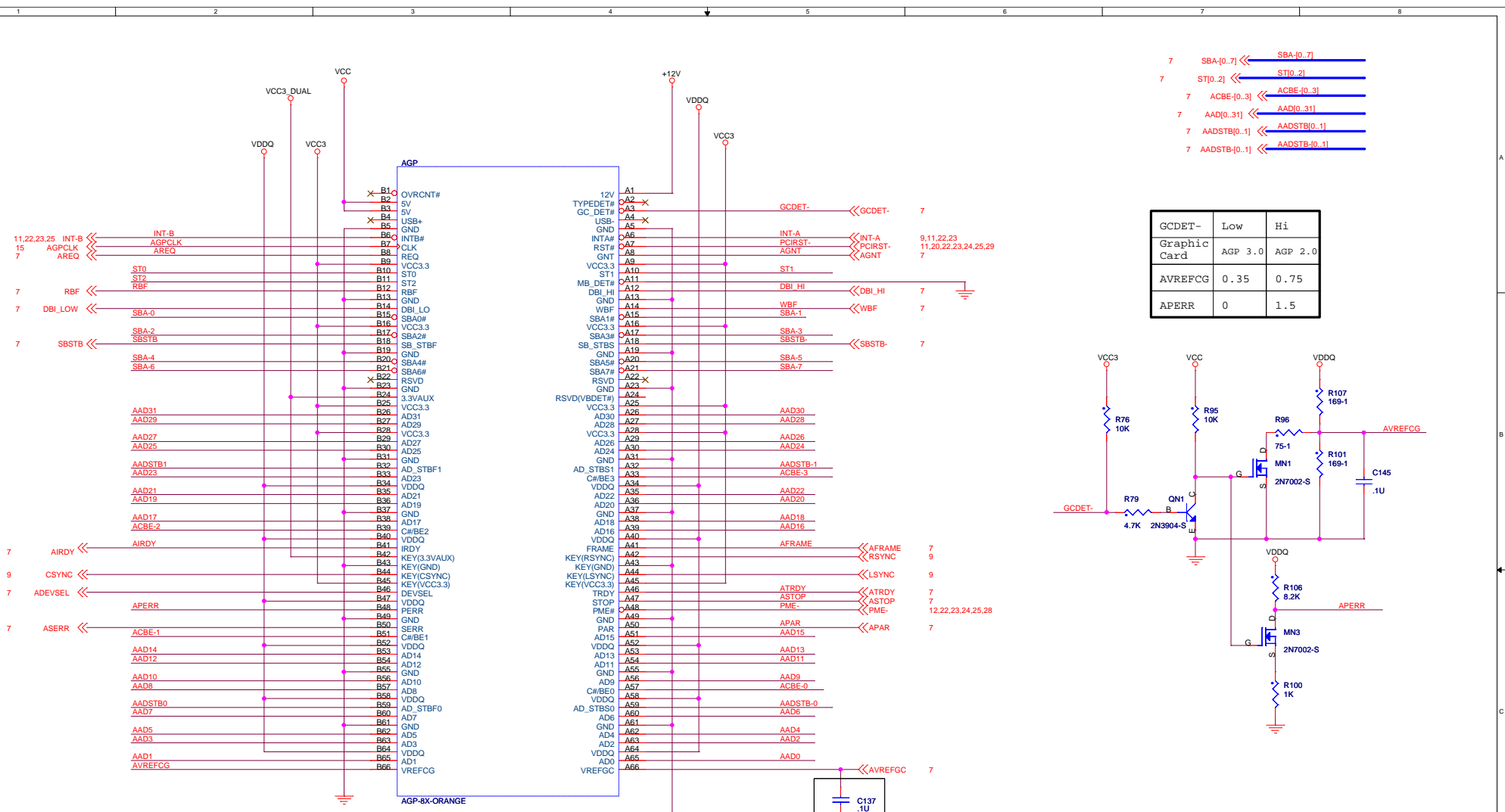

AGP CONNECTOR DECOUPLING
put CAP close to AGP slot each POWER PIN

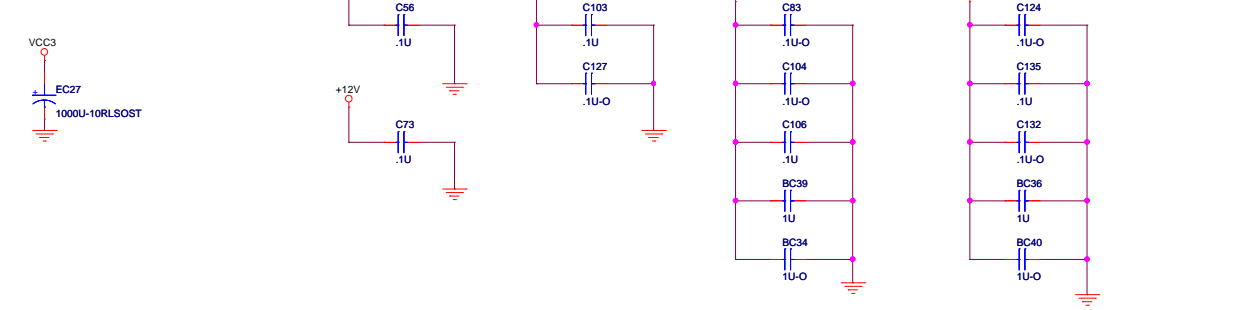

Mounted with 661FX

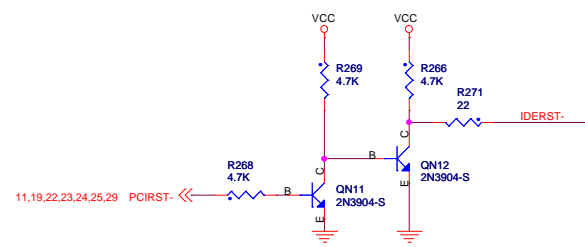
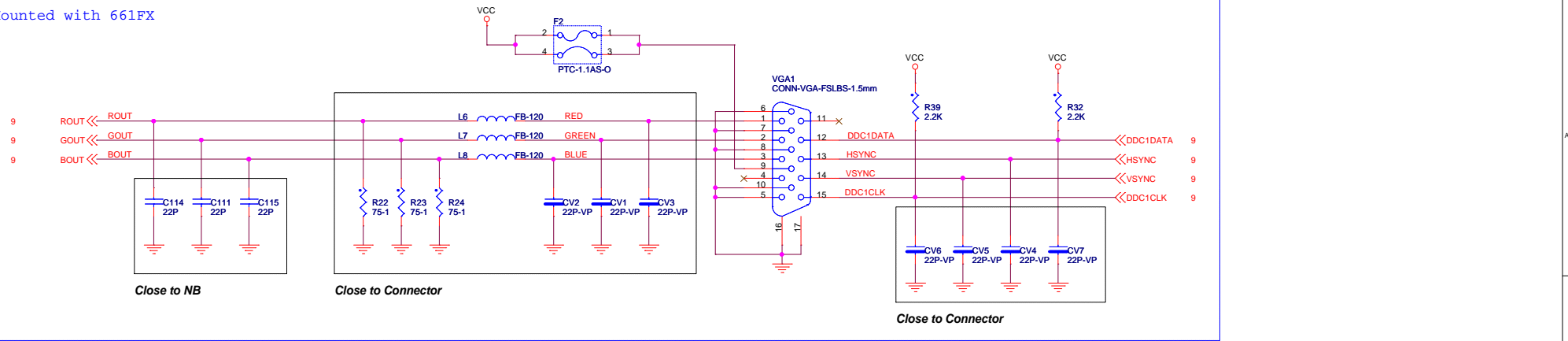



11 IDEDA[0..15] << IDEDA[0..15]

11 IDEDB[0..15] << IDEDB[0..15]

PRIMARY

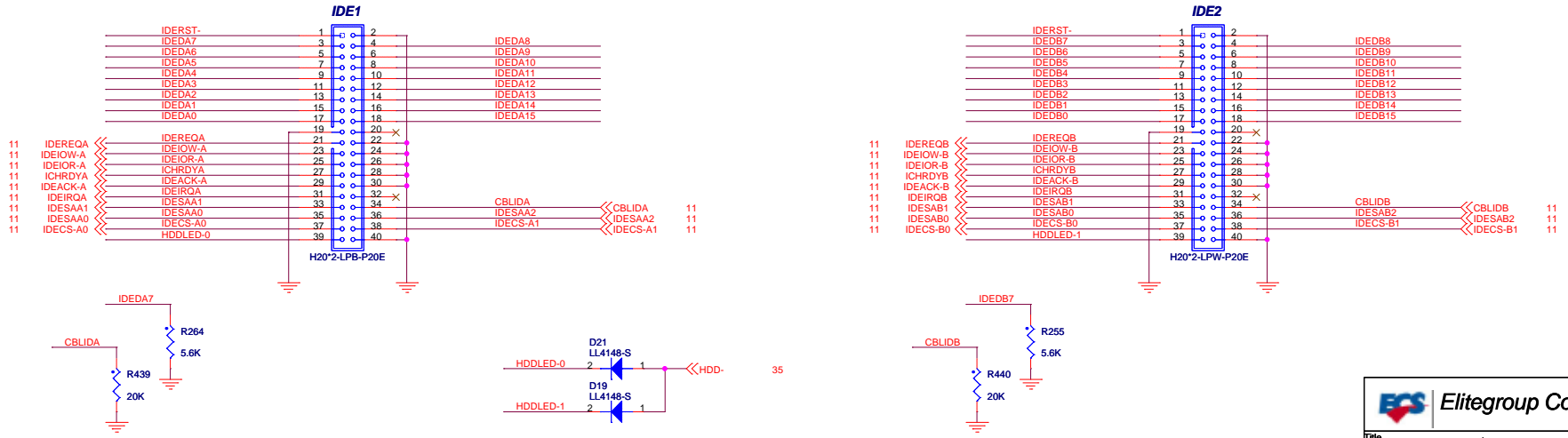
SECONDARY



 Elitegroup Computer Systems	
Title 648/661FX/661GX-M7	
Size	Document Number
Custom	VGA / IDE
Date:	Monday, March 14, 2005
Sheet	20 of 36
Rev	1.1

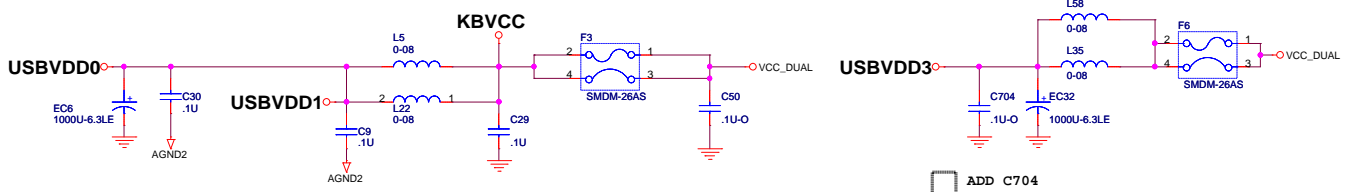
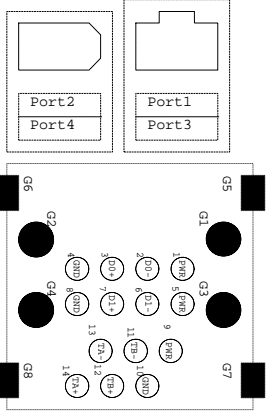

ADD C704

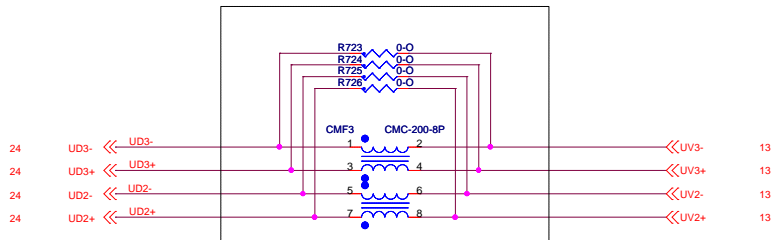

Close to USBLAN1 connector

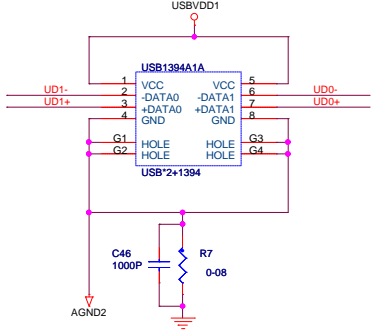

USB port	
Control 0	0, 3, 6
Control 1	1, 4, 7
Control 2	2, 5

ADD 1394A3

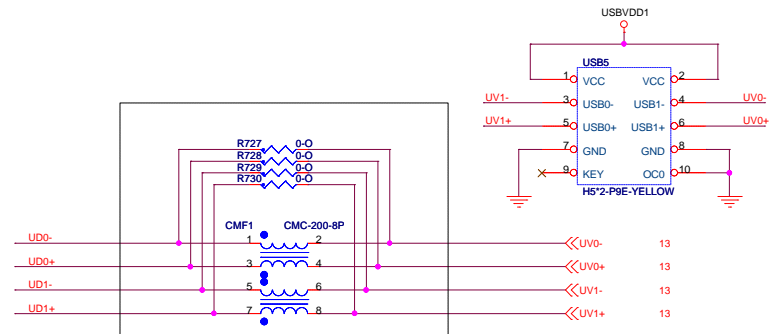
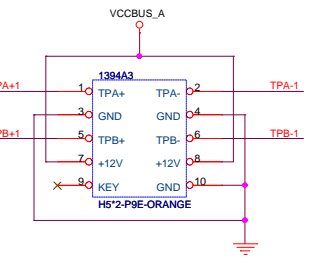

Close to USB1394A_J1 connector

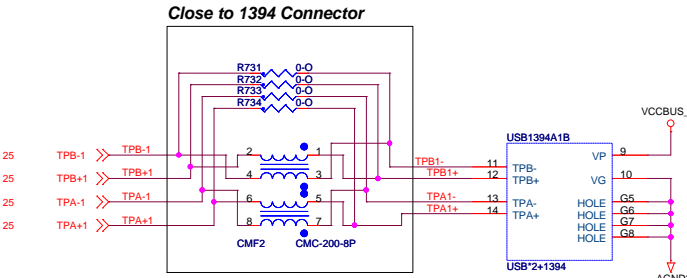

Close to 1394 Connector

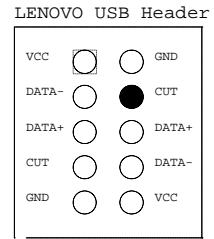
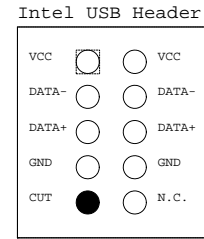
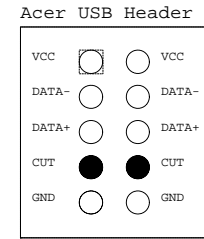
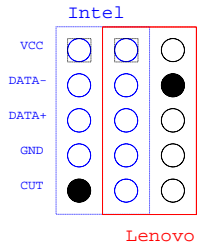
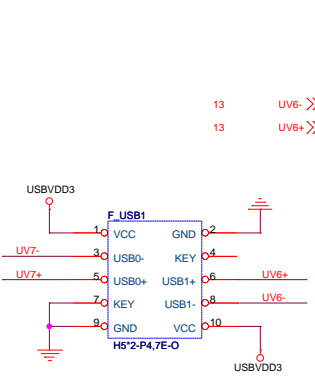
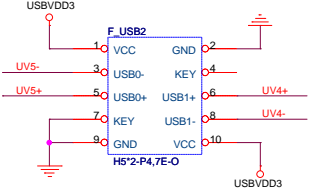
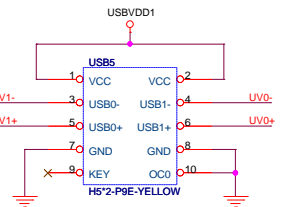

Elitegroup Computer Systems

Title: **648/661FX/661GX-M7**

Size: Custom Document Number: **USB Connector** Rev: 1.1

Date: Monday, March 14, 2005 Sheet: 21 of 36

PCI Slot 1 & 2

11,23,24,25 CBE[0..3] << AD[0..31]
 11,23,24,25 AD[0..31]

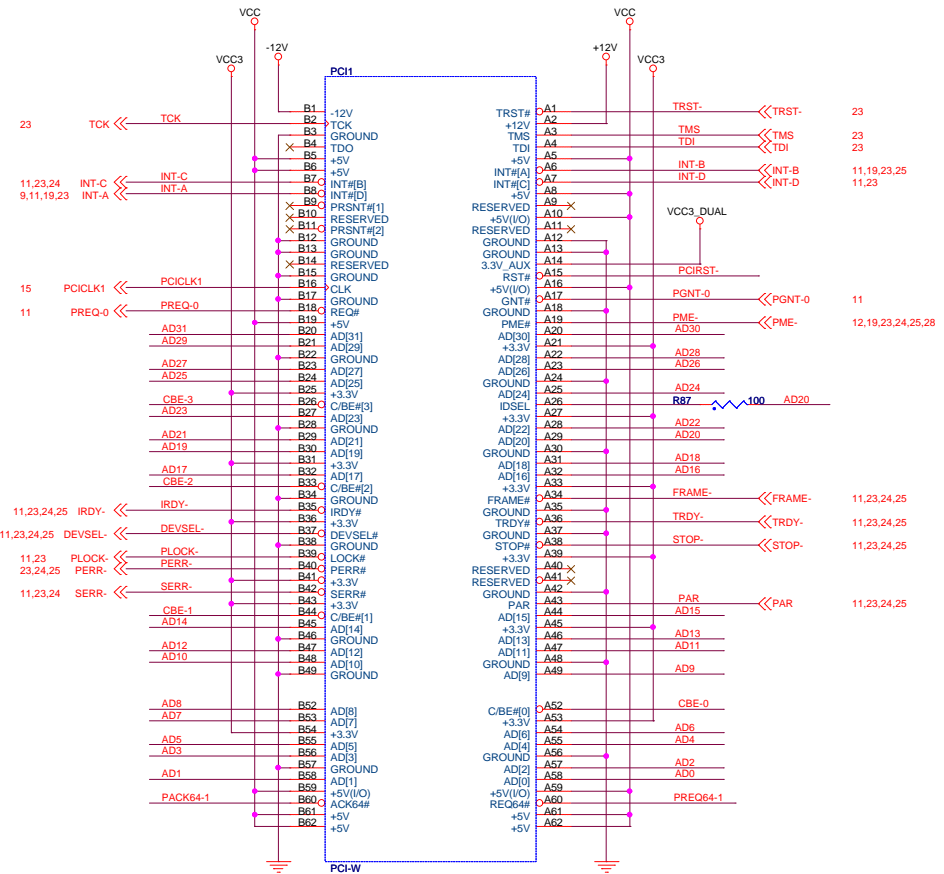

IDSEL=AD20
 INT[B,C,D,A]

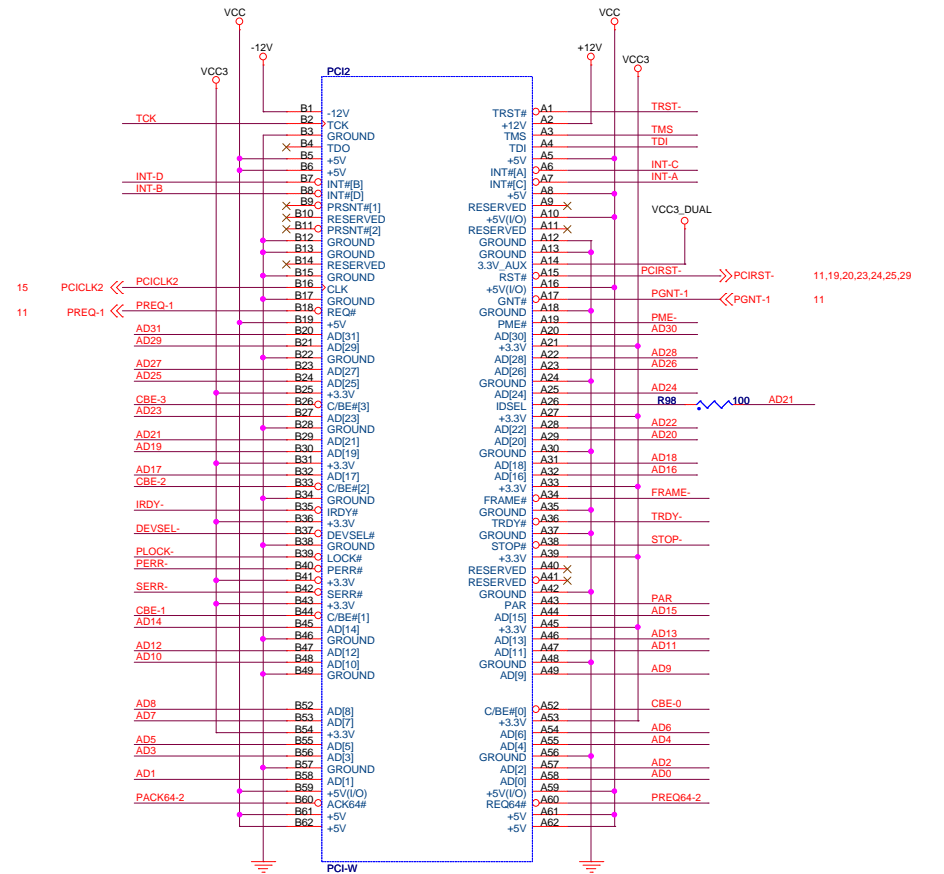

IDSEL=AD21
 INT[C,D,A,B]

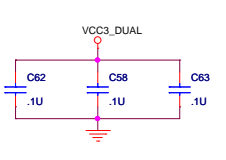
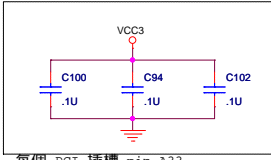
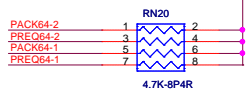
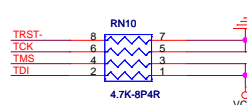
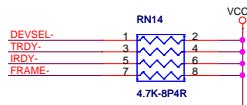
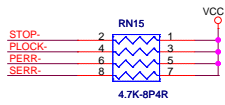

每個 PCI 插槽 pin A33 各放一顆

Elitegroup Computer Systems

Title: **648/661FX/661GX-M7**

Size: Custom Document Number: **PCI Slot1,2** Rev: 1.1

Date: Monday, March 14, 2005 Sheet: 22 of 36

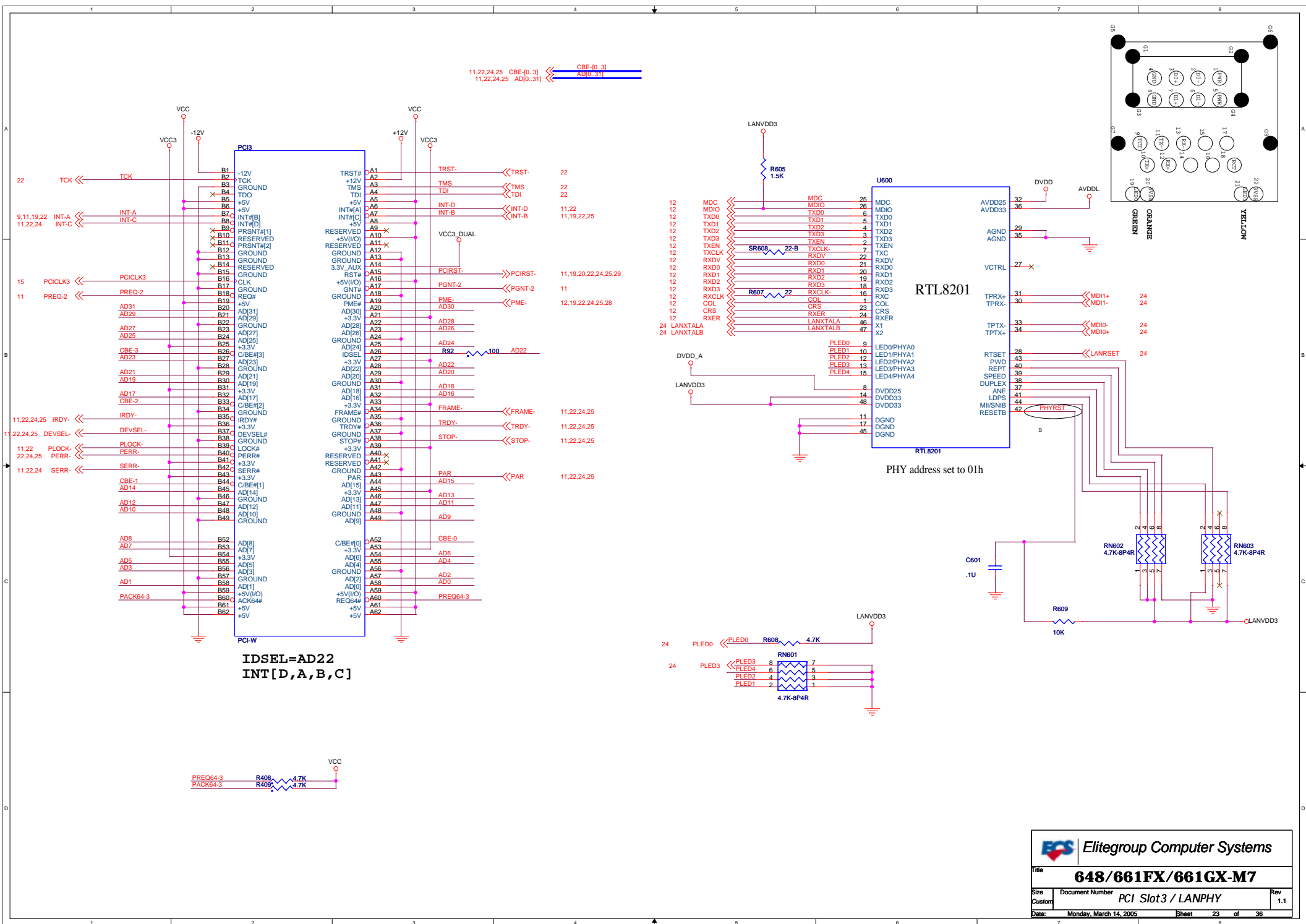

11,22,24,25 CBE-[0..3] << CBE-[0..3]
 11,22,24,25 AD[0..31] << AD[0..31]

IDSEL=AD22
 INT[D,A,B,C]

PHY address set to 01h

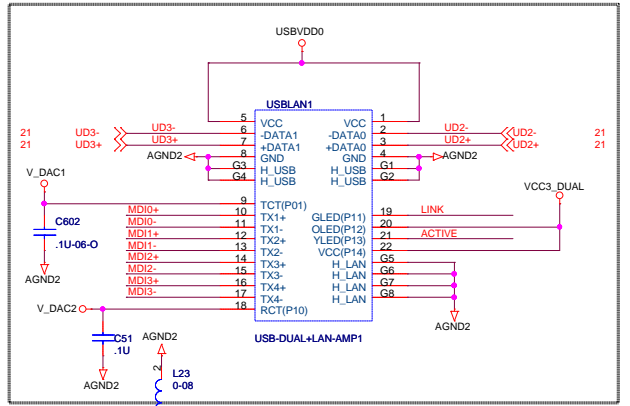
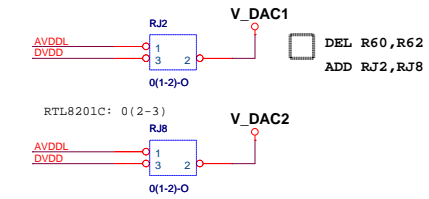
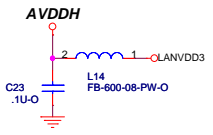
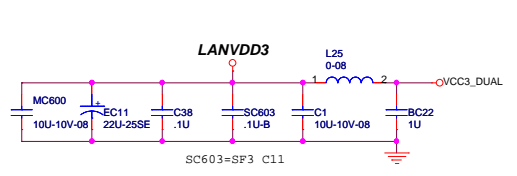
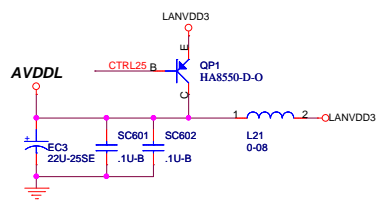
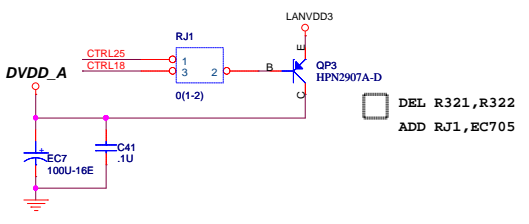
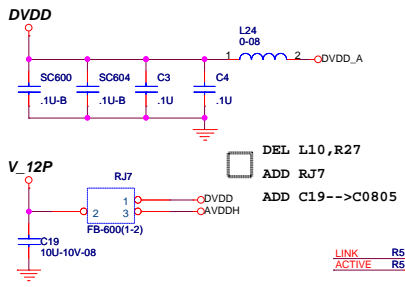

At RTL8100C application, remove R21, R28, R12, R14, C18, C10, C52, C53, C54, and change C51 value from .01uF to .1uF.

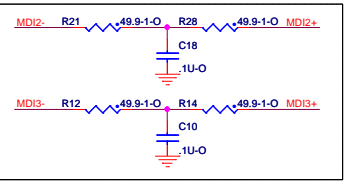
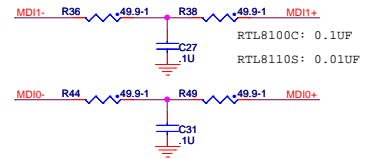

RTL8100C: OPEN
RTL8110S: Mounted

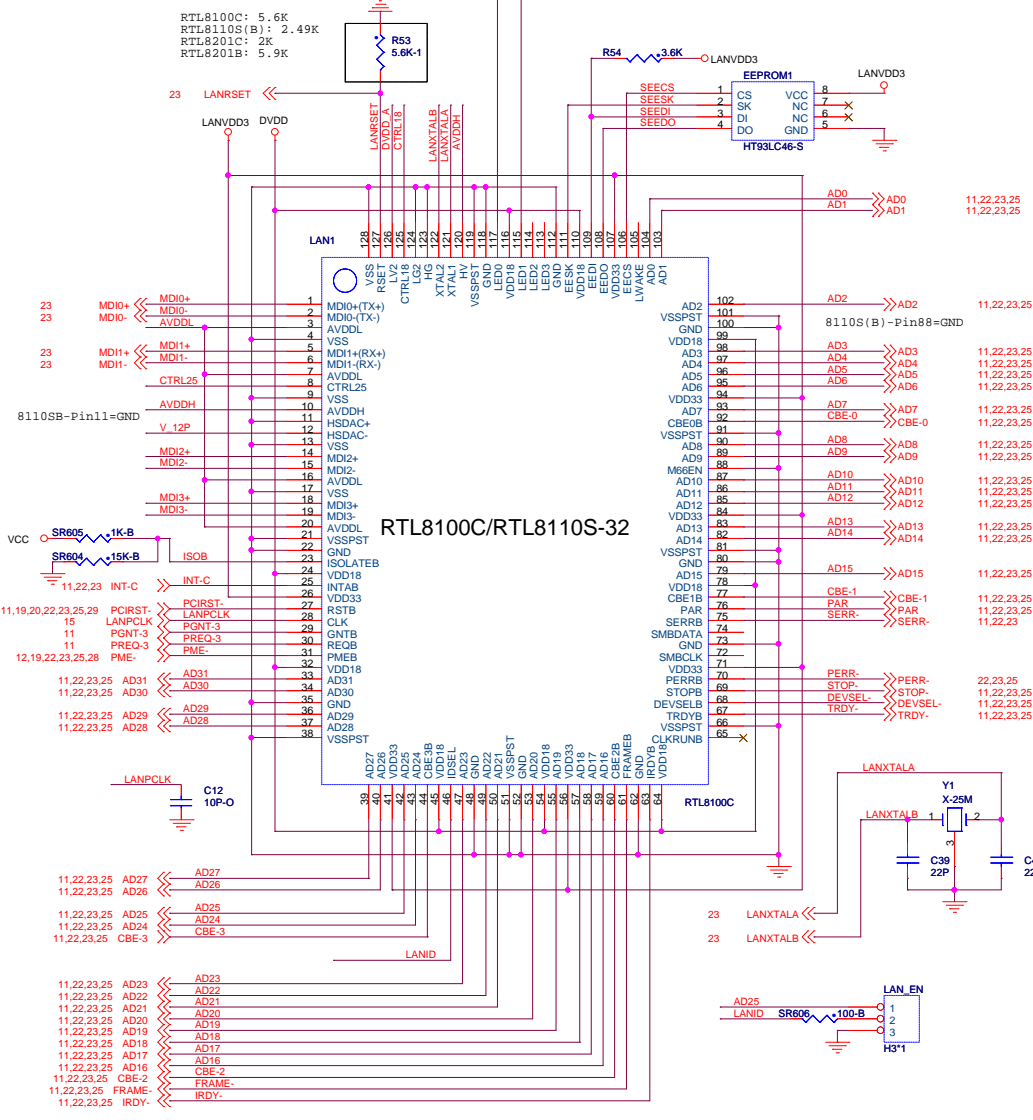

	8100C	8110S	8110SB
VDD3	3.3V	3.3V	3.3V
AVDDH	X	3.3V	3.3V
AVDDL	3.3V	2.5V	2.5V
DVDD_A	2.5V	1.8V	1.2V
DVDD	2.5V	1.8V	1.2V
V_12P	2.5V	X	3.3V

At RTL8100C application, use Pulse H1267.
At RTL8110S-32 application use Pulse H5007.

Elitegroup Computer Systems

Title: **648/661FX/661GX-M7**

Size: Custom Document Number: LAN(8100C/8110S) Rev: 1.1

Date: Tuesday, April 19, 2005 Sheet: 24 of 36

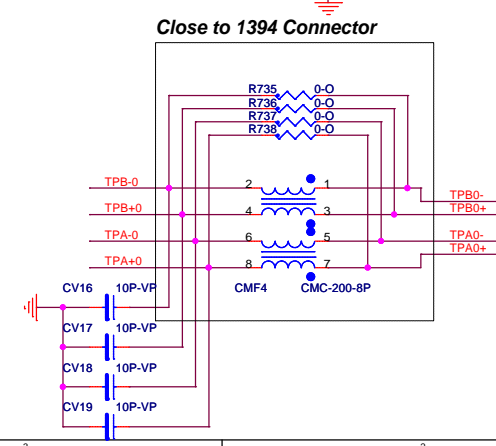
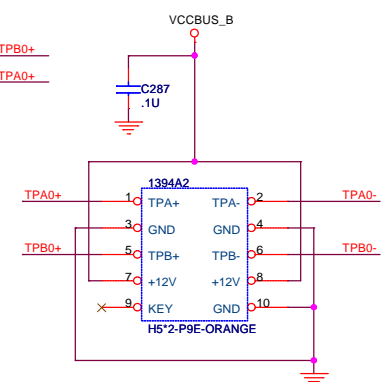
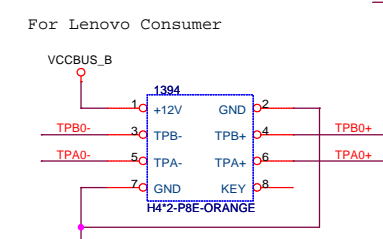
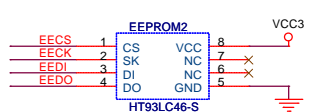
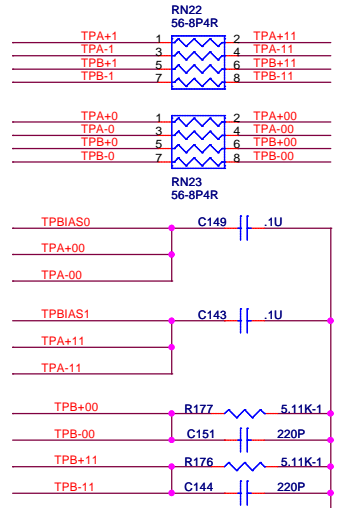
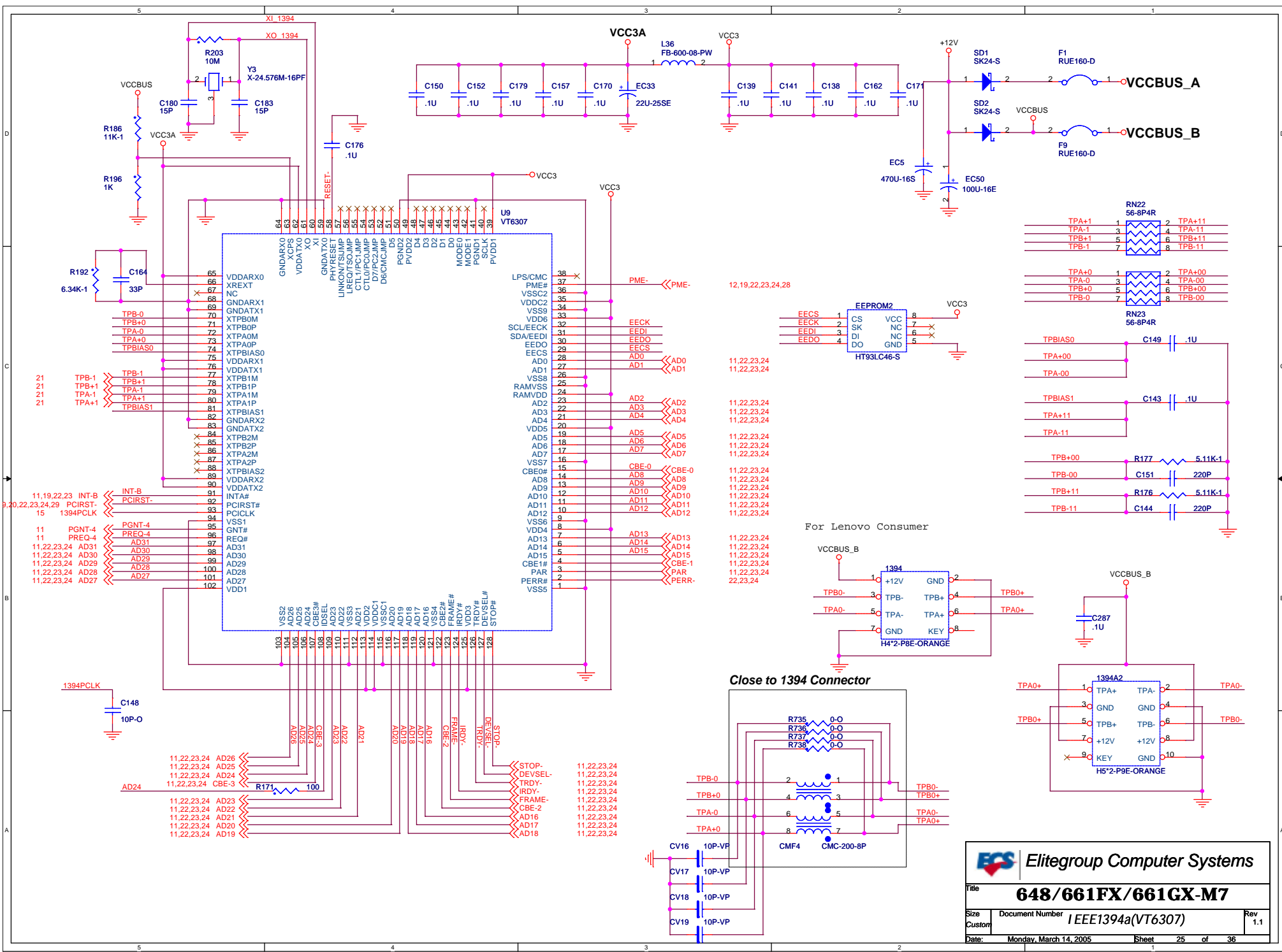

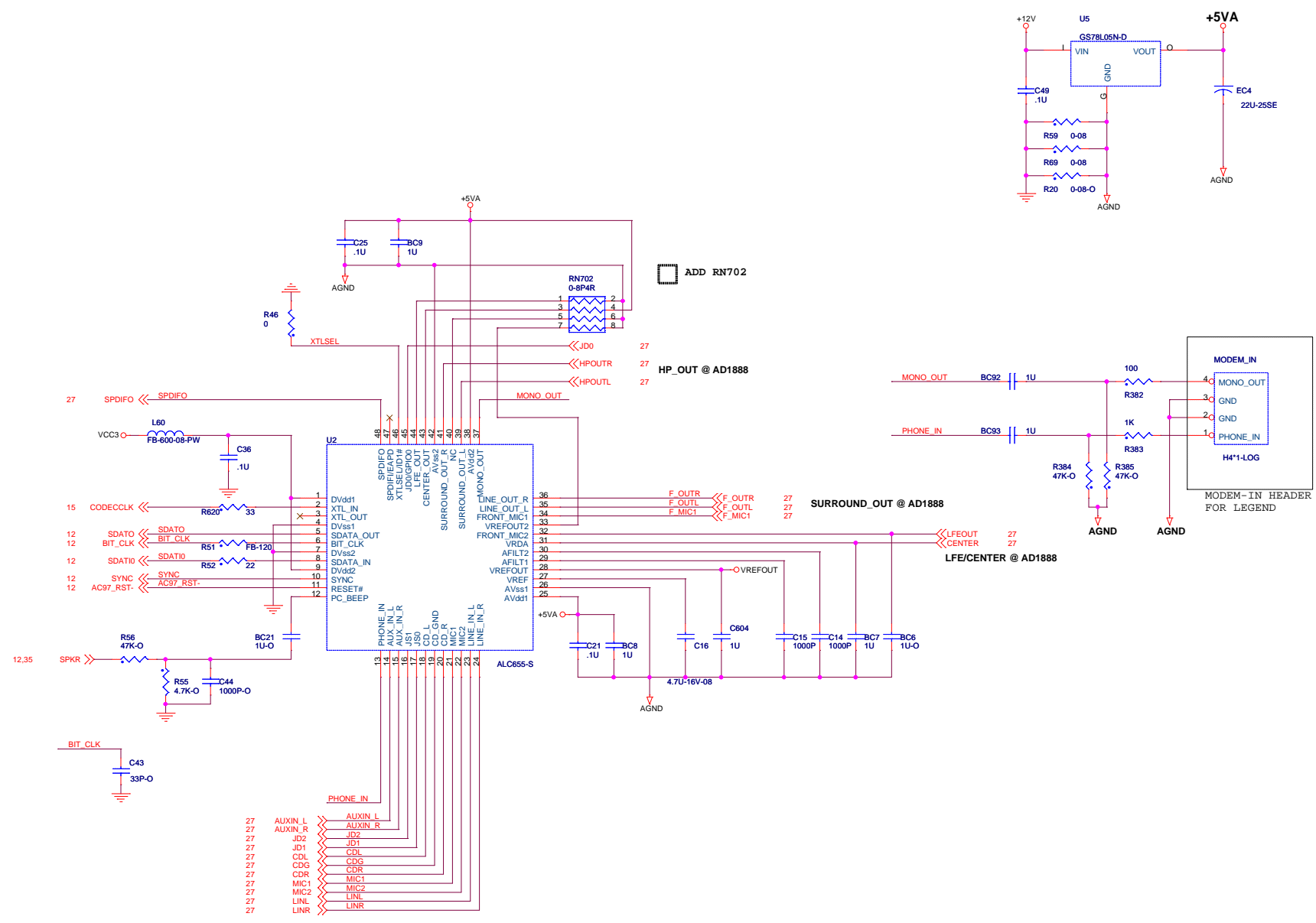

ADD RN702

HP_OUT @ AD1888

SURROUND_OUT @ AD1888

LFE/CENTER @ AD1888

Title 648/661FX/661GX-M7	
Size Custom	Document Number Audio Codec
Date Monday, March 14, 2005	Rev 1.1
Sheet 26	of 36

ADD BC708, BC709, R739, BC1

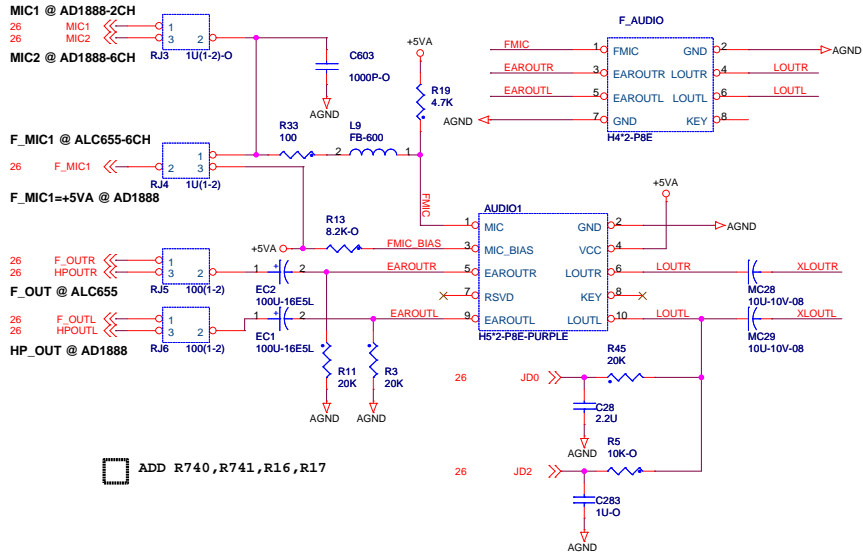

ADD R740, R741, R16, R17

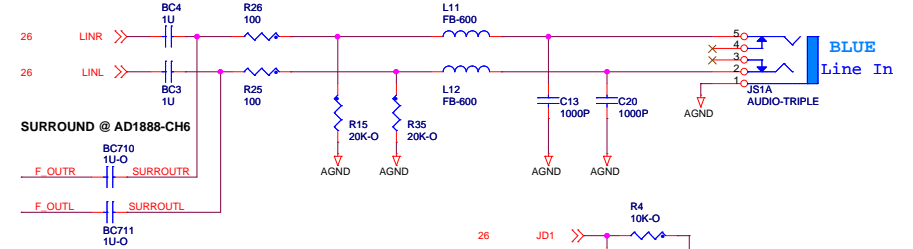
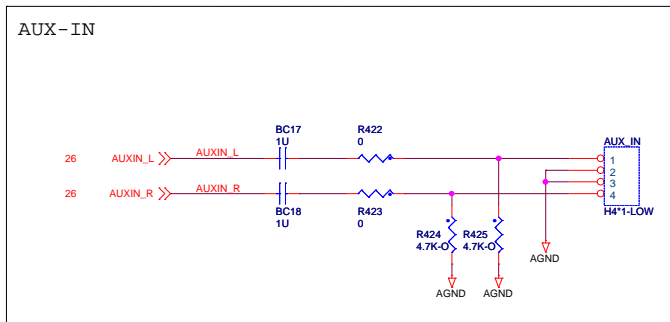
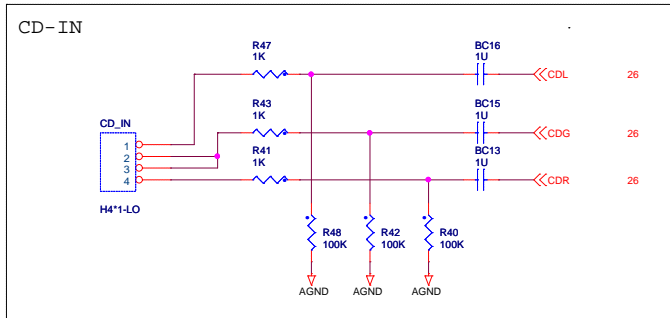

ADD BC710, BC711

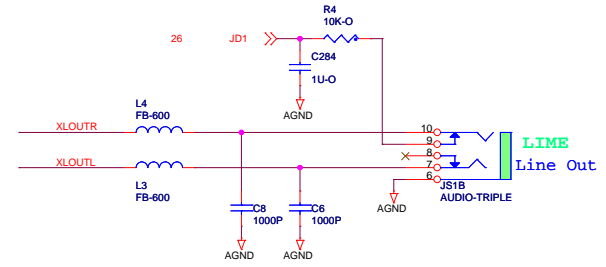

ADD BC712, BC713

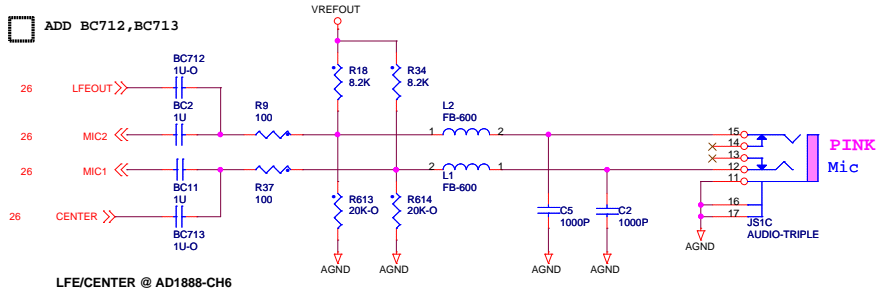

ADD ACER 3-PIN SPEC

SPDIF-Out Pin Definition1

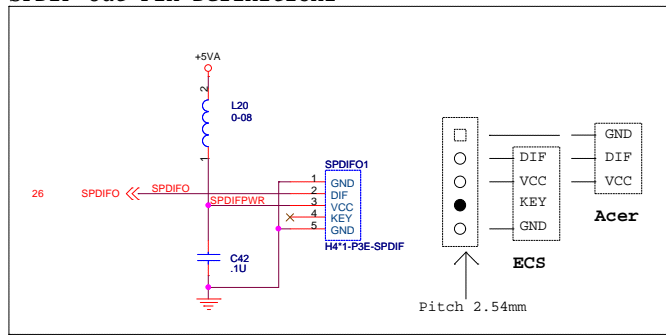

SPDIF-Out Pin Definition2

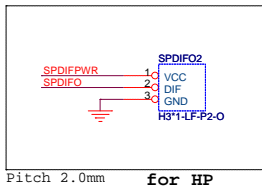

ECS Elitegroup Computer Systems

Title: **648/661FX/661GX-M7**

Size: Custom Document Number: **Audio Interface** Rev: 1.1

Date: Monday, March 14, 2005 Sheet: 27 of 36

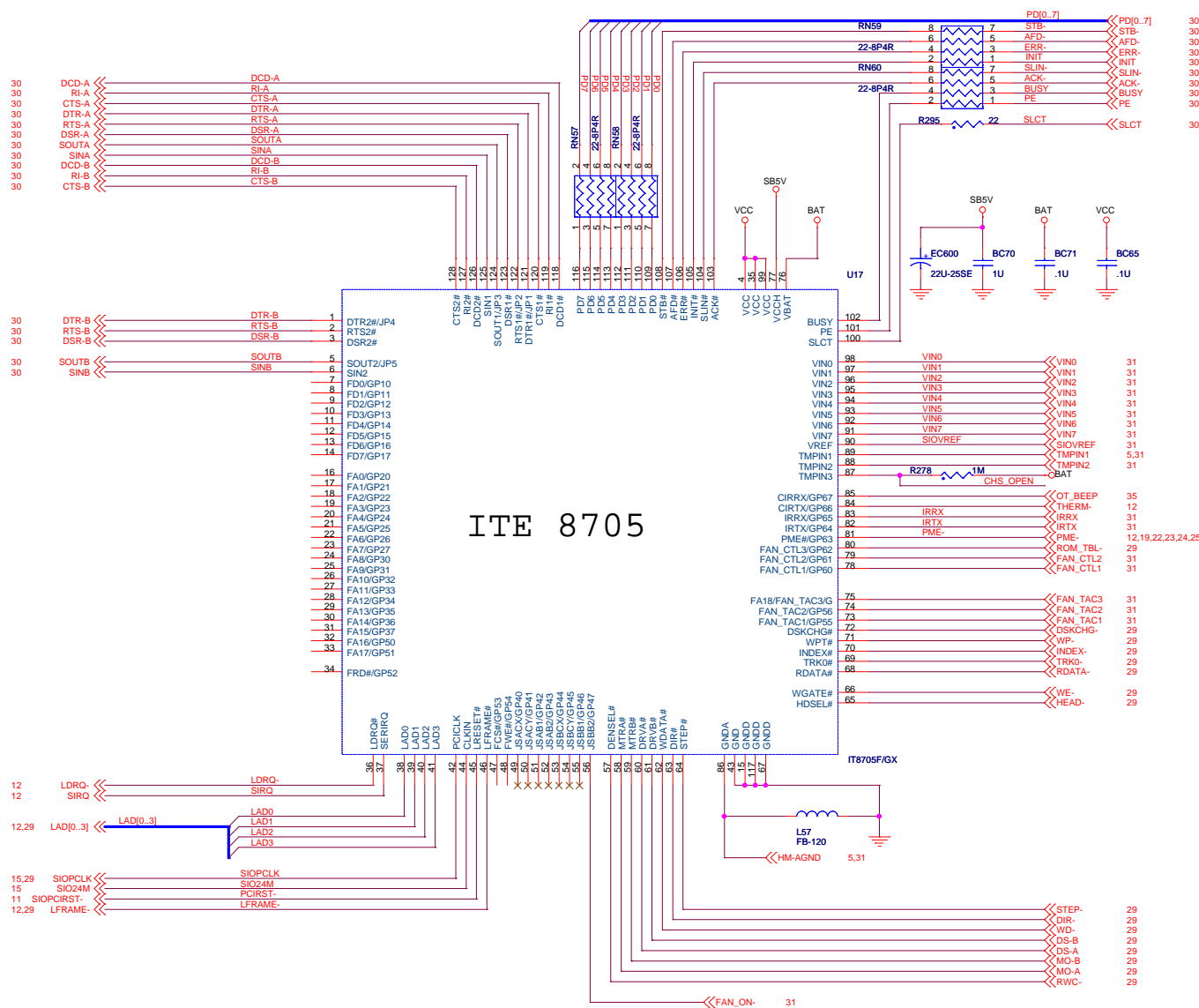

ITE 8705

		High	Low
GPIO62	BootBlockProtect	Disable	Enable

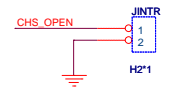

ITE 8705 POWER ON TRAPS

- 1.If use LPC ROM, pull down DTR#A RTS#A SOUTA DTR#B
- 2.If use Legacy 2MB flash rom, pull high DTR#A RTS#A SOUTA DTR#B
- 3.If use Legacy 4MB flash rom, pull high DTR#A RTS#A SOUTA DTR#B

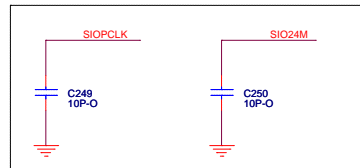
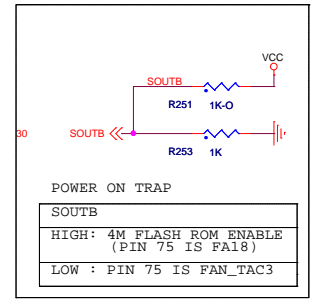

Place near to ITE8705

Elitegroup Computer Systems

Title: **648/661FX/661GX-M7**

Size: Custom Document Number: Super I/O Rev: 1.1

Date: Monday, March 14, 2005 Sheet: 28 of 36

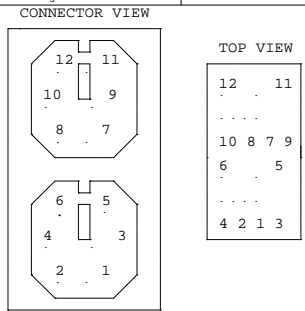

JP3	BIOS PROTECT
OPEN	DISABLE
SHORT	ENABLE

LPC INTERFACE ROM

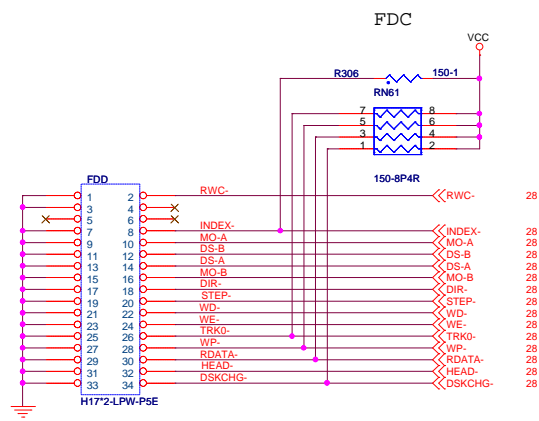
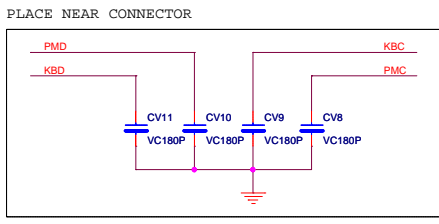
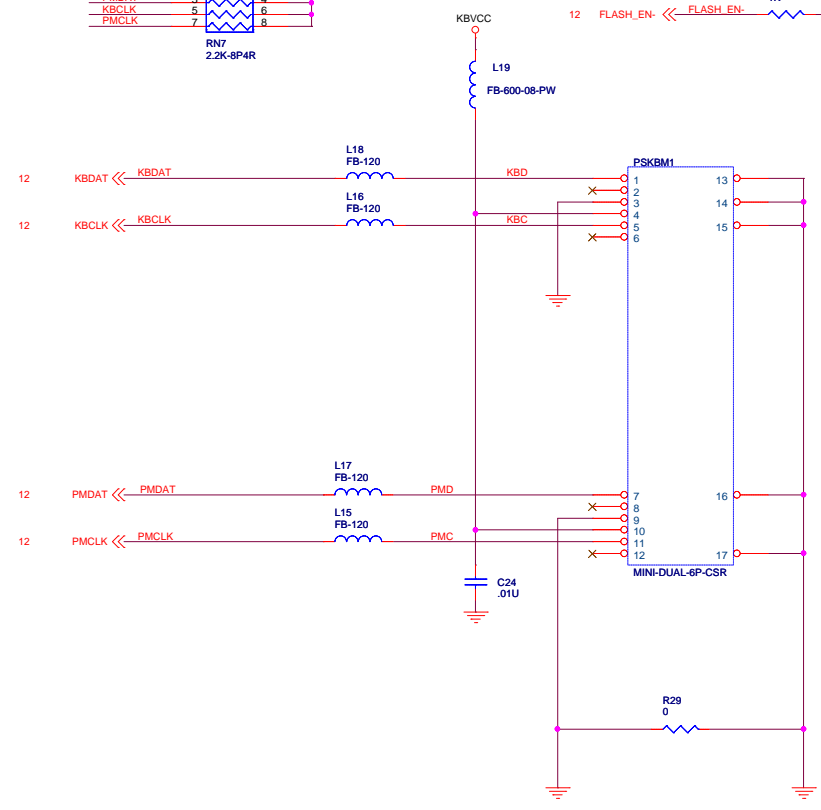
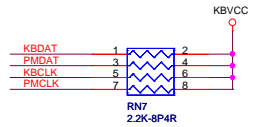
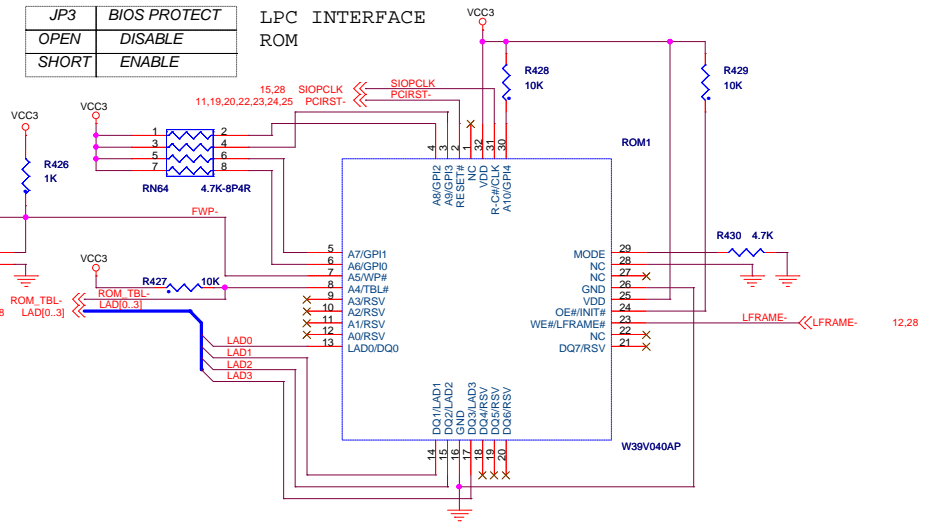

Title 648/661FX/661GX-M7	
Size Custom	Document Number KB/MS/ROM/FDC/I/R
Date: Monday, March 14, 2005	Sheet 28 of 36

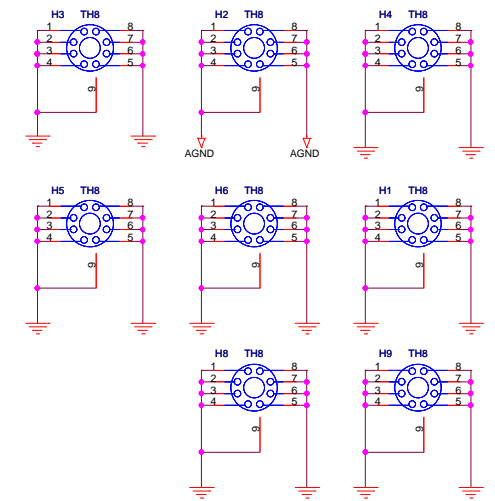
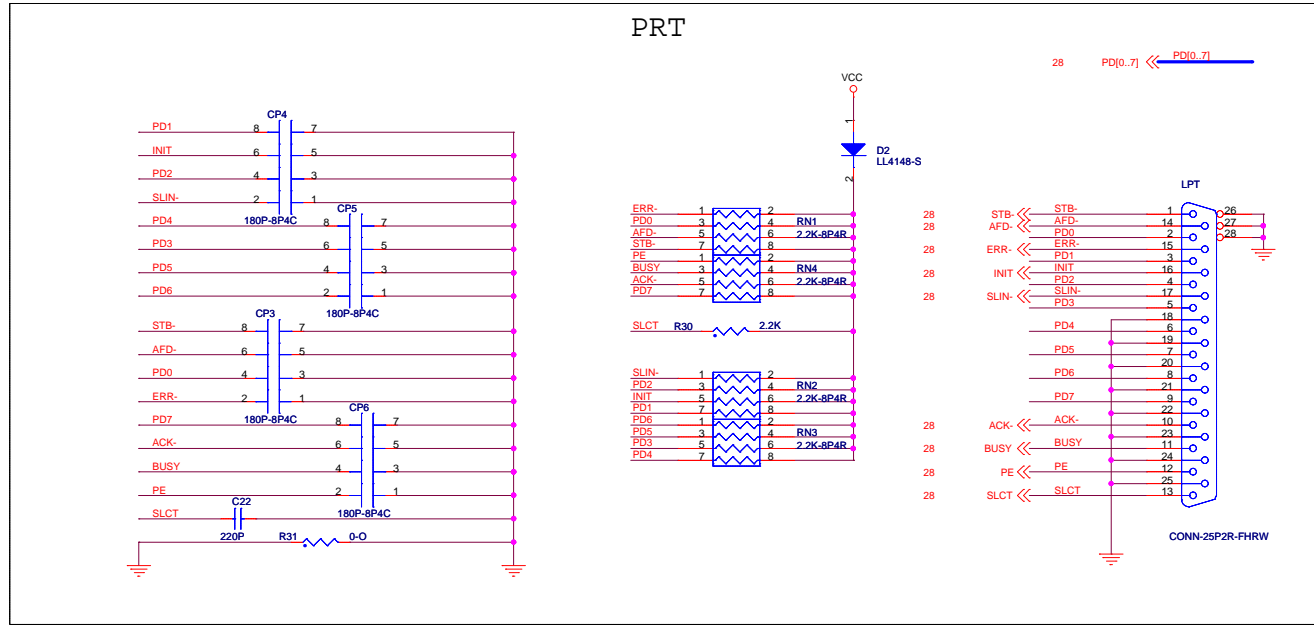
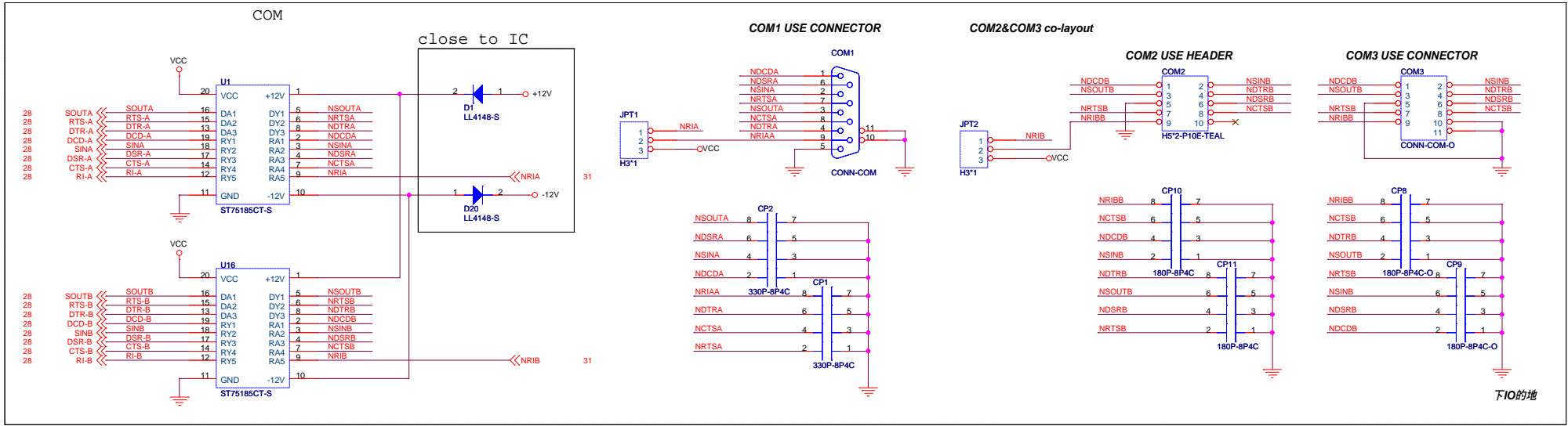

Layout :

Power Signals : CPUFAN, CASEFAN, PWRFAN trace width should > 20 mil with current 200 mA .

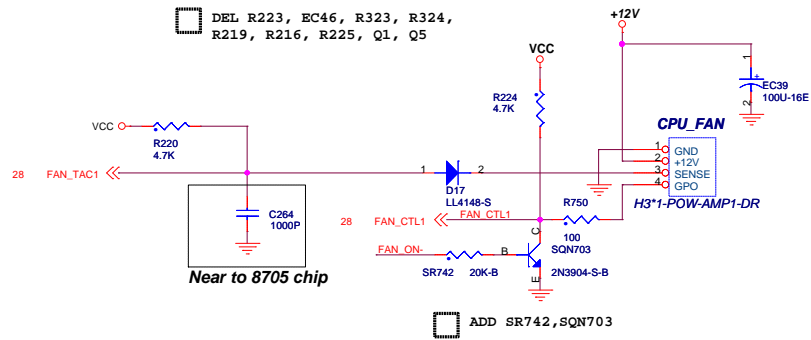

FAN pin 3 - SENSE is 0' C
Some Fans are totem pole

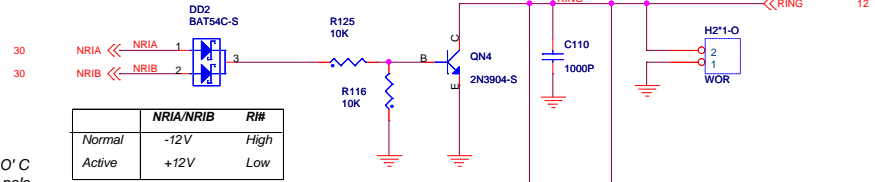

DEL D700

modify SQN702, SR740, SR741, SR742, R417-->SR417

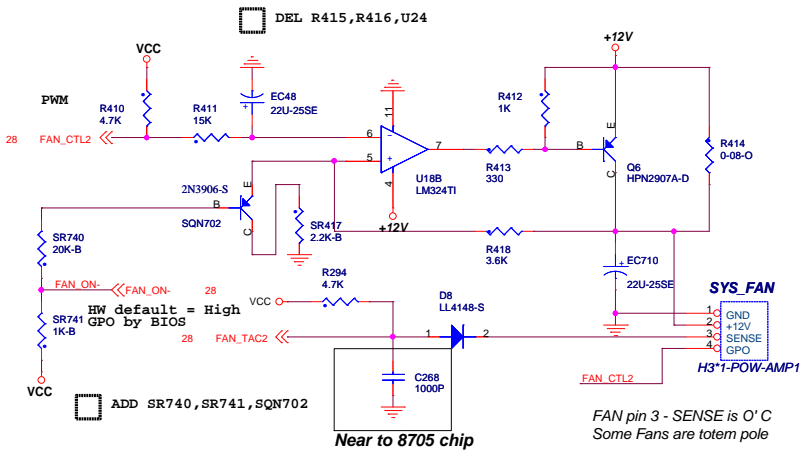

FAN pin 3 - SENSE is 0' C
Some Fans are totem pole

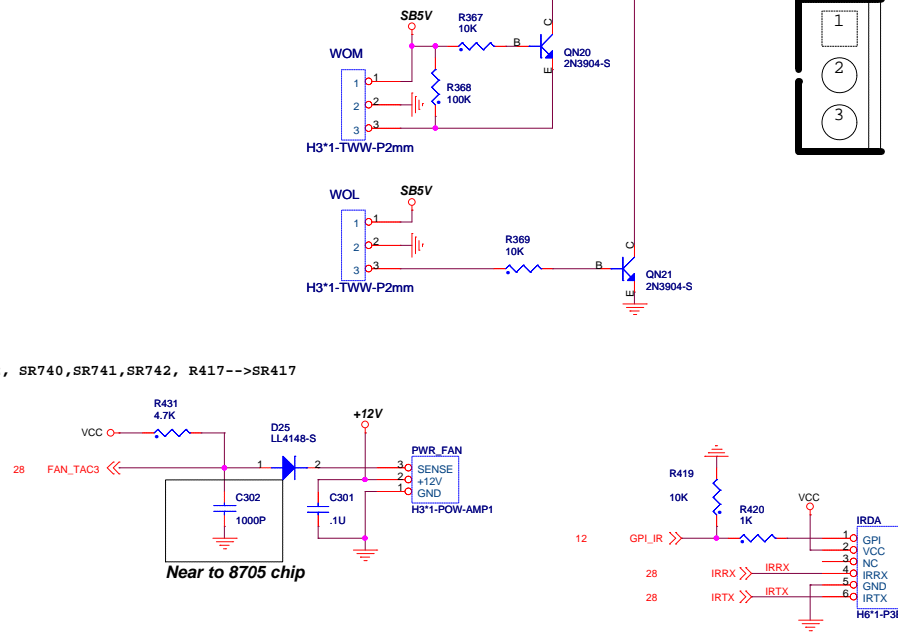

Voltage Monitor

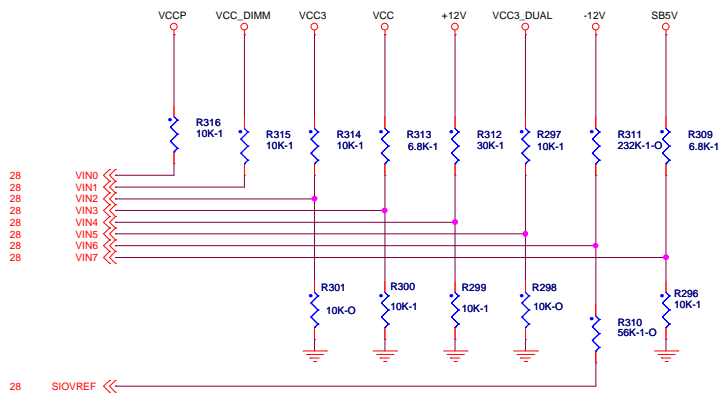

Temperature Monitor

Choosing method of measuring temperature by either thermistor or diode

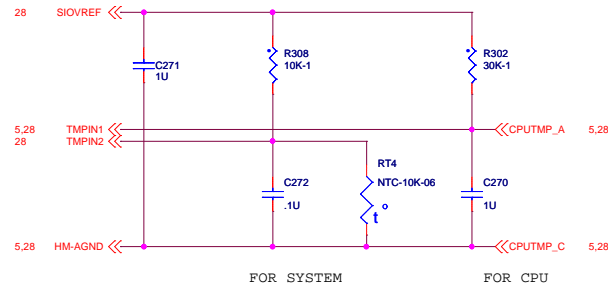

Elitegroup Computer Systems

Title: **648/661FX/661GX-M7**

Size: Custom Document Number: **HM / FAN / RING** Rev: 1.1

Date: Monday, March 14, 2005 Sheet: 31 of 36

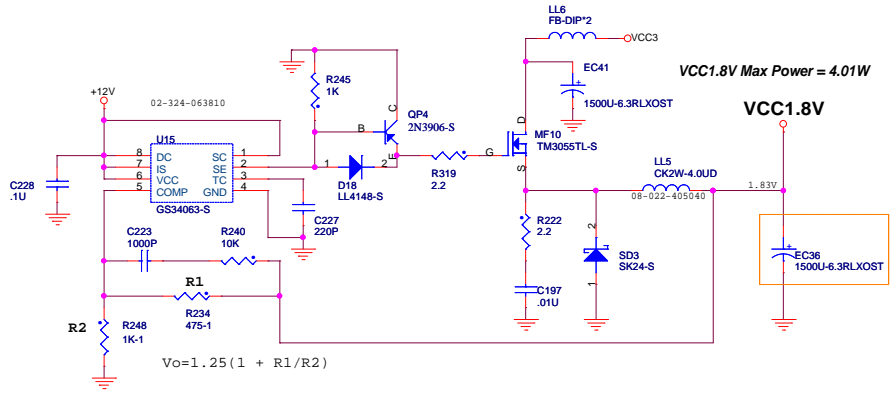

$$V_o = 1.25(1 + R1/R2)$$

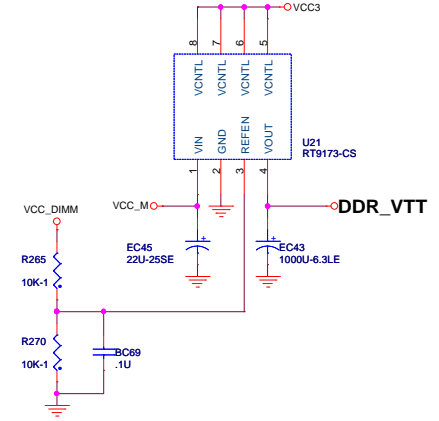
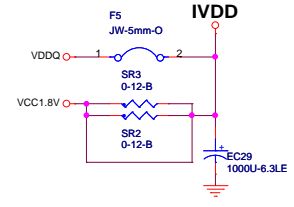

	IVDD	VCC1.8V	
648	1.8V	1.8V	short two power plane, one regulator
648FX	1.9V	1.9V	short two power plane, one regulator
661FX	1.8V	1.8V	short two power plane, one regulator or two regulator

	AUX_IVDD	SB1.8V	
648	1.8V	1.8V	short two power plane, one regulator
648FX	1.9V	1.9V	short two power plane, one regulator
661FX	1.8V	1.8V	short two power plane, one regulator

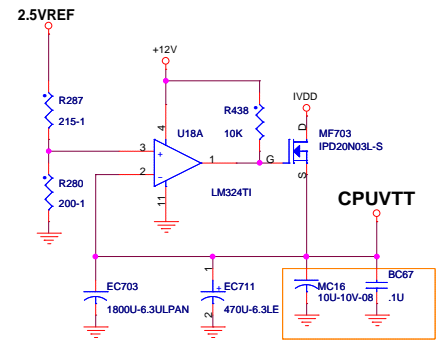

Modify EC703

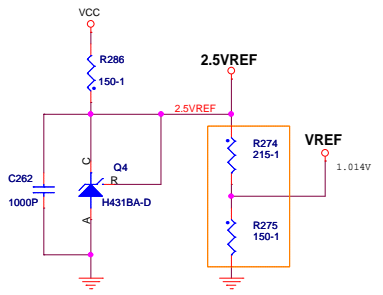

$$VCC1.5V \text{ Max Power} = 0.3 \cdot (0.289 + 2.35) = 0.7917W$$

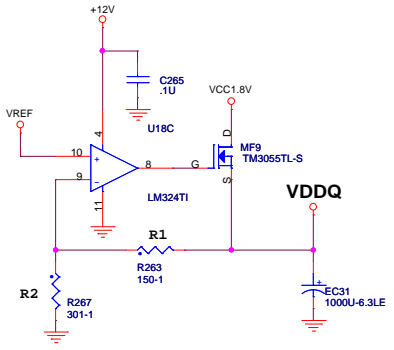

$$V_o = VREF(1 + R1/R2)$$

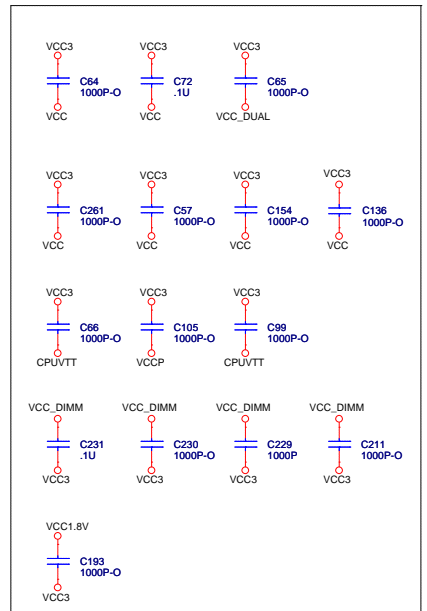
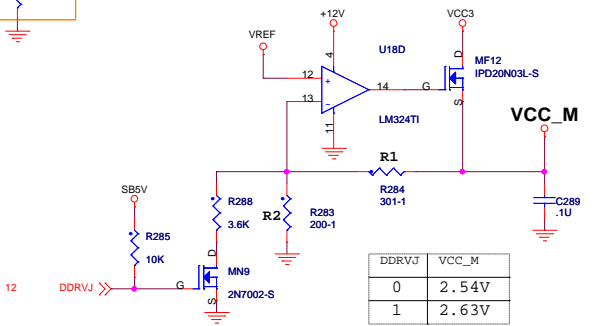

平均分佈在POWER PLAN 和 PLAN 之間

AUTO VOLTAGE SWITCH FOR ACPI STATE 3

1. IN S0_S1
THIS CIRCUIT PASSES THE NORMAL POWER

2. IN S3,S4,S5
THIS CIRCUIT PASSES THE STANDBY POWER

NOTE:
BECAUSE OF THE MAXIMUM CURRENT FROM
POWER SUPPLY IS ONLY ABOUT 750-1000mA
SO IF YOU WANT TO SUPPORT WAKE UP
FROM S3 BY USB, YOU MUST HAVE A POWER
SUPPLY WITH LARGER POWER. (ADDITIONAL
500mA PER USB PORT)

VCC3_DUAL & VCC5_DUAL

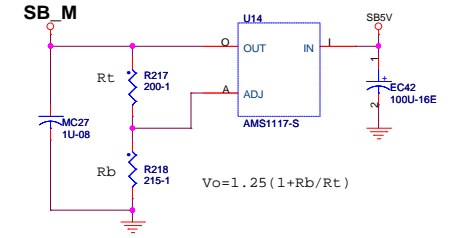
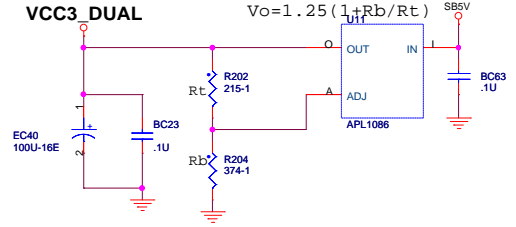
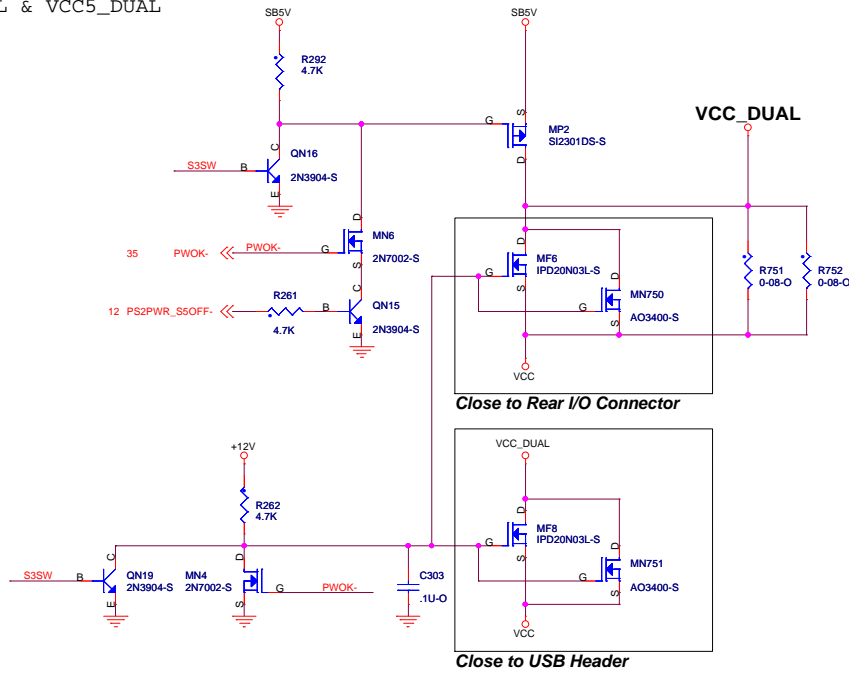

SB1.8V (For SB) 450mA

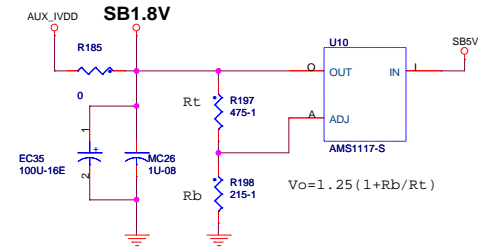

VCC3_DUAL AUX_IVDD (1.5V For NB) 10mA

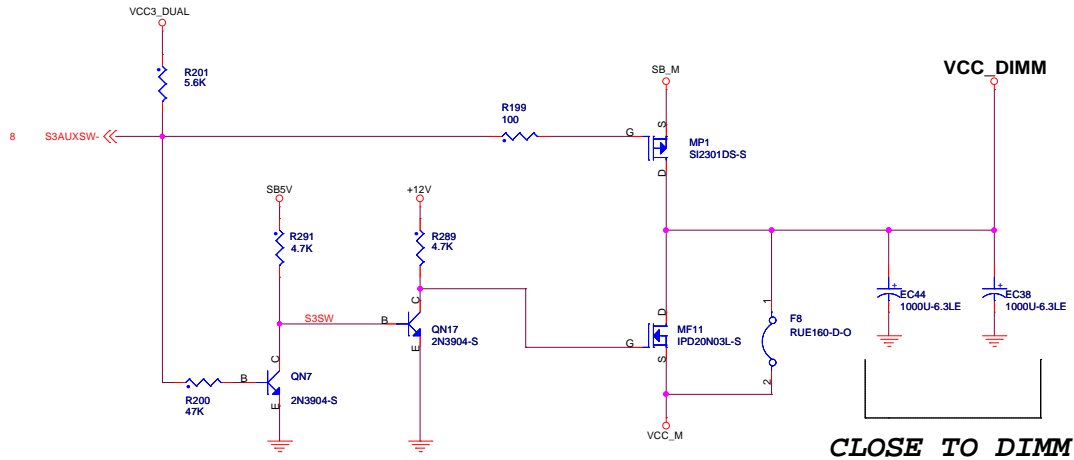
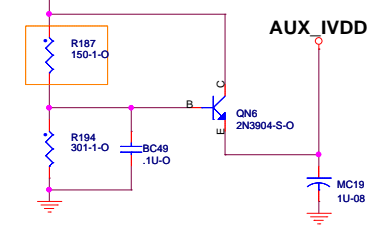

CLOSE TO DIMM

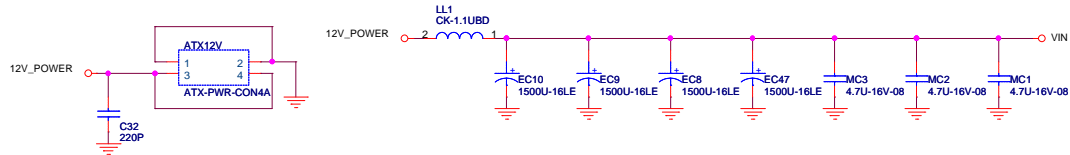

4 CPUVID[0..5] >> CPUVID[0..5]

ADD R158
DEL MN700, QN700, RN700, C704

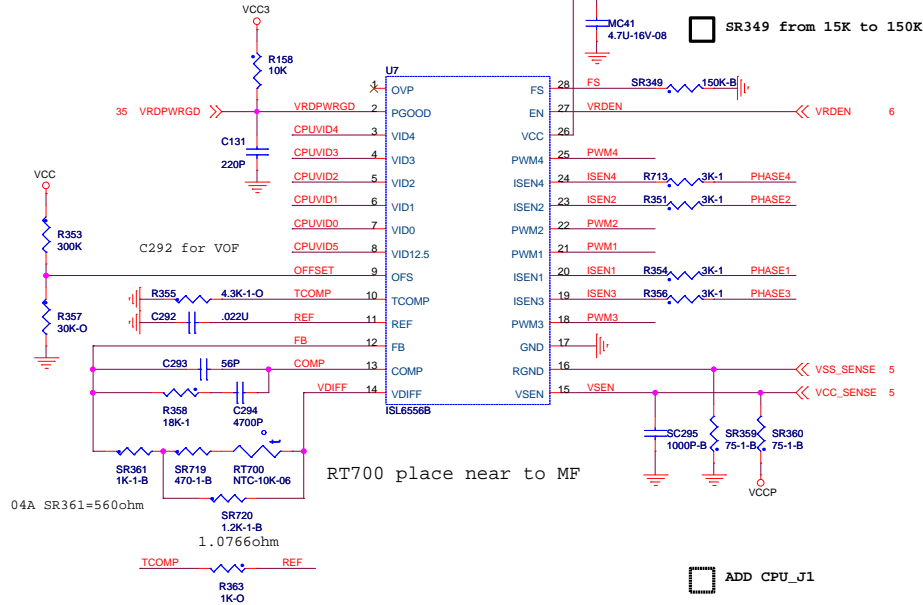

RT700 place near to MF

NORTHWOOD: LOW
PRESCOTT: HIGH

ADD CPU_J1

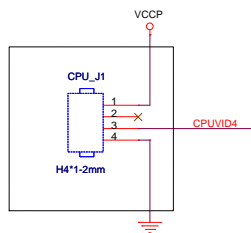

MAIN BOARD W/O VTT
HEADER..4*1 180D.P2.0mm..

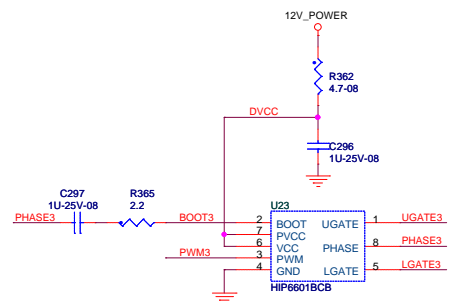
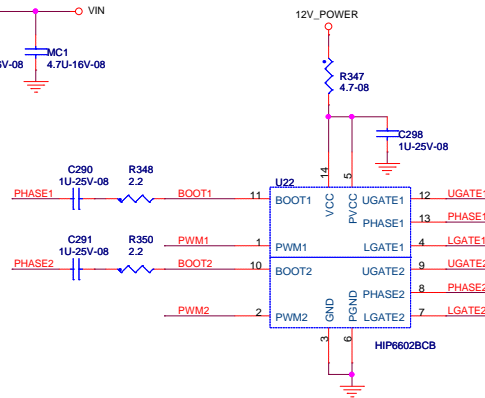

DEL R714

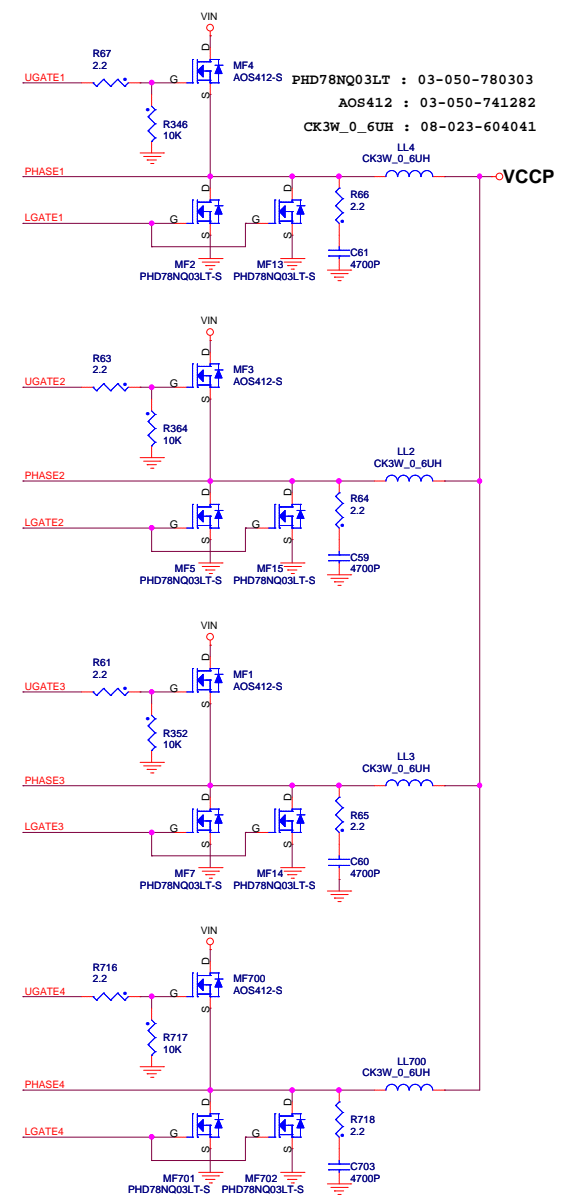
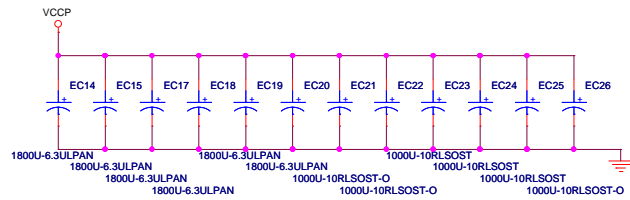
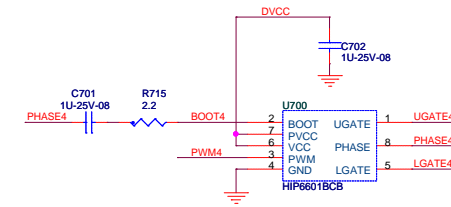

648/661FX/661GX-M7	
Title	648/661FX/661GX-M7
Size	Document Number
Custom	VRD10 (CPU Vcore)
Date:	Monday, March 14, 2005
Sheet	34 of 36

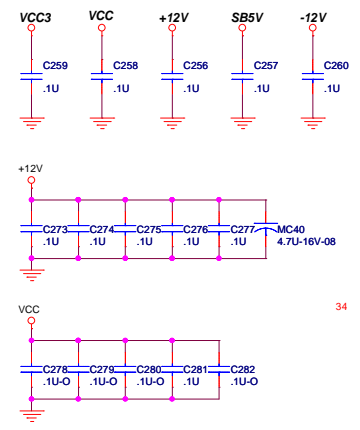
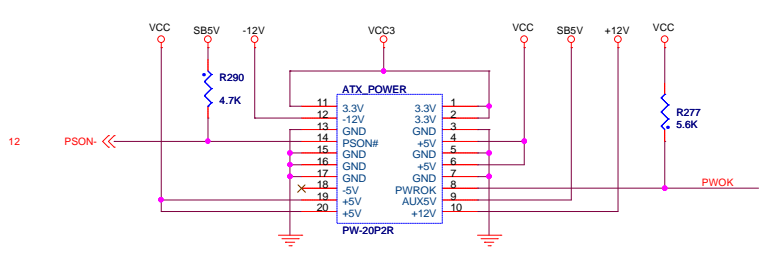

Layout :
Bypass capacitors close to ATX power connector for EMI solution.

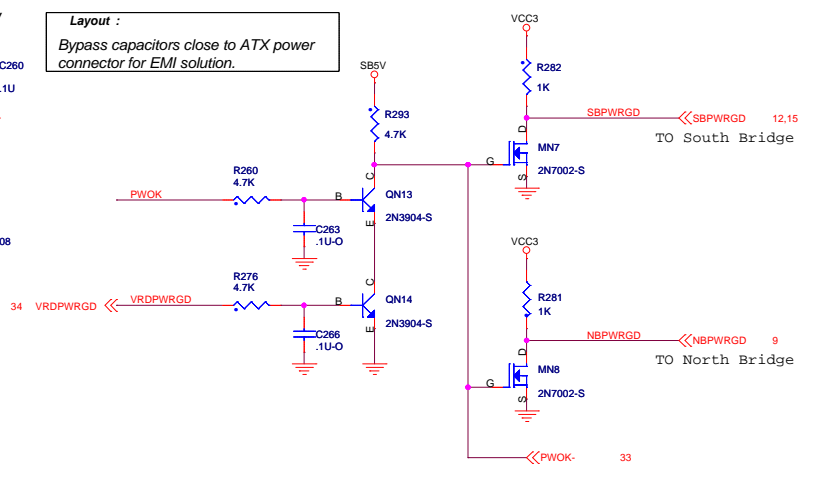

Hardware Reset Circuit

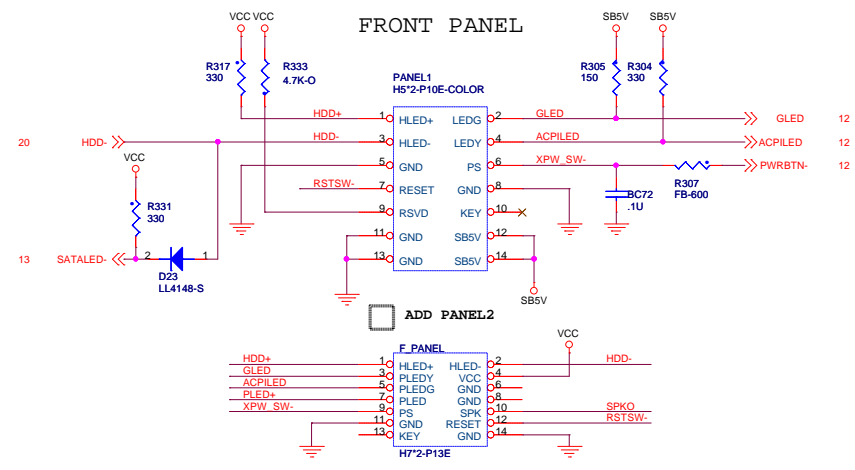

Intel Front Panel

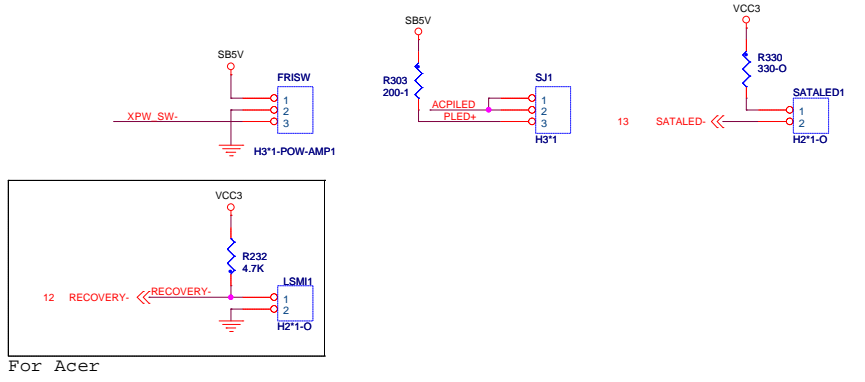
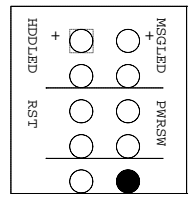

CLR_CMOS	CLEAR CMOS
1-2	CLEAR
2-3	NORMAL

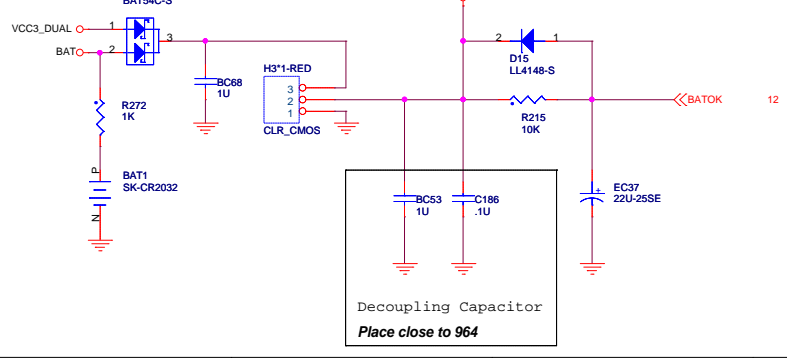

Decoupling Capacitor
Place close to 964

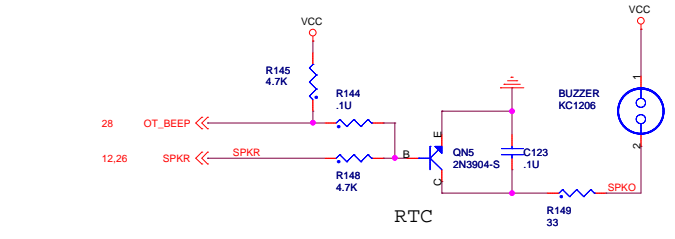

NOTE!
1.The RTCVDD is 3V
2.Decoupling capacitor must be close to 635 RTCVDD pin.
3.RTC circuit must strictly follow SiS's recommended design.
SiS is not responsible for RTC problems from foreign designs.

1. BOM Attention

(1) South Bridge

Option	SIS964	SIS964L
U13	964 964142	964L 964162
R241	374 374010	X
R71, R74	33 330000	X
R72, R75	49.9 499010	X
R331	330 330001	X
D23	1N4148 03-021-214890	X
SATA1, SATA2	10-020-007690	X

(3) On-Board VGA

Option	Support	No Support
U8	661FX 661141	648FX 648161
L30, L31, L32, L6, L7, L8	FB-120	X
C112, C116, C117, BC35	1U	X
C118, C119	.1U	X
MC36, MC37	10U	X
R136	130 130011	X
R134, R143	33	X
R128, R135	100	X
VGA1	10-717-015010	X
C111, C114, C115	22P	X
R22, R23, R24	75	X
R32, R39	2.2K	X
CV1-7	22P-VP 04-130-220003	X
F2	O	X

(3) LAN

Option	8100C 10/100 Mbps	8110S 1Gbps	8110SB 1Gbps	8201BL 10/100 Mbps	8201CL 10/100 Mbps
LAN1	RTL8100C 01-230-100351	RTL8110S 01-230-110350	RTL8110SB	RTL8201BL 02-448-201861	RTL8201CL 02-462-201860
R53	5.6K-1	2.49K-1	2.49K-1	5.9K-1	2K-1
R12, R14, R21, R28	X	49.9	X	X	X
C10, C18	X	0.1u	X	X	X
C52, C53, C54	X	0.01u	X	X	X
C51	0.1u	0.01u	0.01u	X	0.1u
RJ2	X	(1-2) 0 ohm	X	X	(2-3) 0 ohm
R604	X	X	X	X	0 ohm
C601	X	X	X	X	0.1u
L14/ C23	X	0 ohm/ 0.1u	0 ohm/ 0.1u	X	X
RJ7/ C19	(1-2)FB-600 /10u-08	X	(2-3)FB-600 /10u-08	X	X
L21	0 ohm	X	X	0 ohm	0 ohm
QP1	X	HA8550	HA8550	X	X
RJ1	(1-2) 0 ohm	(2-3) 0 ohm	(2-3) 0 ohm	X	X
RJ8	X	X	X	X	(2-3) 0 ohm
QP3	HPN2907A	HA8550	HA8550	X	X
RN601, RN602, RN603	X	X	X	4.7K-8P4R	4.7K-8P4R
C601	X	X	X	0.1u	0.1u
R608/ R609	X	X	X	4.7K/ 10K ohm	4.7K/ 10K ohm
R605	X	X	X	1.5K ohm	1.5K ohm
R602, R603, R607	X	X	X	22 ohm	22 ohm
SR600/ SR601/ SR602/ SR603/ SR607/ SR608	X	X	X	22 ohm-B	22 ohm-B
SR606	150 ohm-B	150 ohm-B	150 ohm-B	X	X
SR604/ SR605	15K/ 1K ohm-B	15K/ 1K ohm-B	15K/ 1K ohm-B	X	X
Y600/ R600	X	X	X	Y-25M/ 0 ohm	Y-25M/ 0 ohm
C166/ C600	4.7K ohm/ X	4.7K ohm/ X	4.7K ohm/ X	22P	22P
R190/ R191	X / 1K ohm	X / 1K ohm	X / 1K ohm	1K ohm/ X	1K ohm/ X
EEPROM1/ EEPROM3	O / X	O / X	O / X	X / O	X / O
R54/ R610	3.6K ohm/ X	3.6K ohm/ X	3.6K ohm/ X	X / 4.7K ohm	X / 4.7K ohm

2. GPIO Function

GPIO	Status	Status		Jumper
		0	1	
GPIO5	* RESERVED	RESERVED	RESERVED	JP4
GPIO6	* RESERVED	RESERVED	RESERVED	JP5
GPIO7	* LAN Selection	LANPHY	PCILAN	N/A
GPIO9	USB, PS/2 S4/S5 Wake Up	Disable	Enable	N/A
GPIO10	DDR Voltage	2.54V	2.63V	N/A
GPIO11	* WHQL	No Support	Support	JPT3
GPIO13	Flash Write Protect	Un-Protect	Protect	

- "*" means that the function is selective and ECS may make changes at any time, without notice in this page.
- Jumper Setting (Header 3*1):
 - 1: (1-2)
 - 0: (2-3)
- Please see Page.12 for more detail jumper function.

JPT3		1-2	2-3
GPIO11		1	0
HP	Clear CMOS	Normal	Clear
TRIGEM	Suspen Mode	S1 & S3	S1

JPT4		1-2	2-3
GPIO5		1	0
HP	Clear Password	Normal	Clear
TRIGEM	BIOS Logo	TG	Commaeul

