

Proven Quality

Coral air
dental unit



FEDESA

More than 35 years of experience manufacturing dental units.

FEDESA offers a wide range of high quality products at very competitive prices - the fruits of our extensive experience and dedication in the dental industry. All our products surpass the expectations of the most demanding professionals. Our work is backed up and guaranteed by a number international certifications. We carefully select our distributors, who assure careful and continual customer service.



Front view of the main factory.



FEDESA. Night view.



Cuspidor assembly

Chair

Equipment



Dental unit
Coral air

Simplicity and reliability

The result of our vast experience in meeting all the requirements of a complete unit, one that is simple and efficient to use and inexpensive to maintain.

Proven Quality

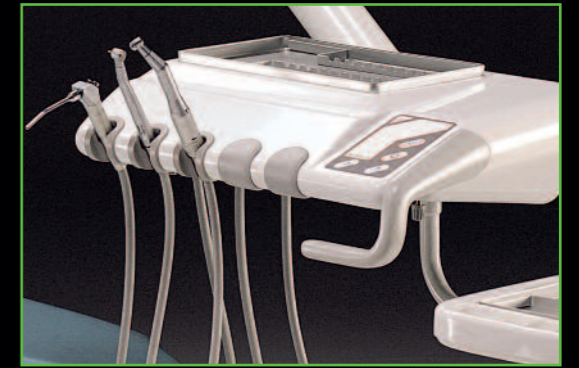

Dental unit
Coral air
Design

**Innovation and functionality,
one unit two alternatives.**

This is the answer to small dental clinics that need a multipurpose and hygienic unit. Its small size makes it more user and patient friendly.

Delivery System.

There are two versions, hanging type and whip arm. In both cases it can be expanded as required. The edgeless control keypad, the lack of asperities and a gas piston compensated arm contribute to an easy maintenance and smooth operations.

Cuspidor.

Its concept is vertical, all the tubings are inside, the aluminium base is compact. There is enough extra room to fit all the different kinds of suction systems. The glass bowl is sturdy, and the clamshell doors allow for an easy access and maintenance.

Chair.

The chair is electromechanical and silent. The backrest and seat are made of foam with a controlled hardness. The extensible headrest has a double articulation. The backrest is fitted with a circular guide. Several systems ensure the safety of the chair end movements.



Coral Lux Dental Unit
in right handed
configuration.



Dental unit
Coral air
Features

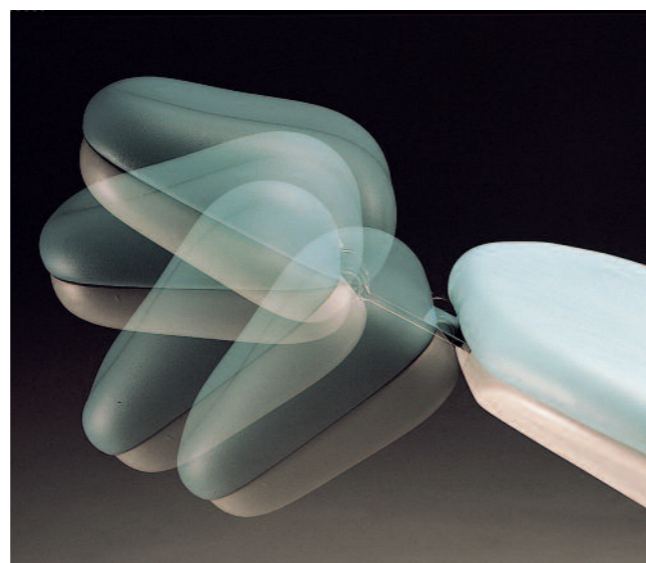

Features and versatility.

Everything has been taken into account to have a multipurpose unit. A choice is given among many options to enhance the equipment. The layout makes it ideal to work with four hands procedures. The design was developed with the cleaning of the clinic and the disinfection of the unit in mind.

The anatomical shape of the seat helps maintain the patient in place and reduces the practitioner workload.



Ref. 801016



Ref. 801015



Ref. 801011



Ref. 801018



Ref. 801003



Ref. 801012



Ref. 801014



Ref. 801006



Ref. 801013



Ref. 801017



Ref. 801004

Dental unit
Coral air

Possibilities



Options and accessories.

The unit has been designed to adapt to the specific needs of the user. The following items may be added to the basic configuration of module for turbine and air rotor: extra modules for rotary instruments, curing light, ultra-sonic scaler, surgical suction, suction canula support, centrifuge separator, etc.

The cuspidor assembly can be ordered fully prepared for the amalgam separator suction system or with an instrument water decontamination system.

FEDESA offers a wide range of colours and textures in its upholstery catalogue. All are fire-proof, washable, strong and seamless.



Dental Unit

The listed floor space and height sizes will help you to ideally place the unit in your dental practice.

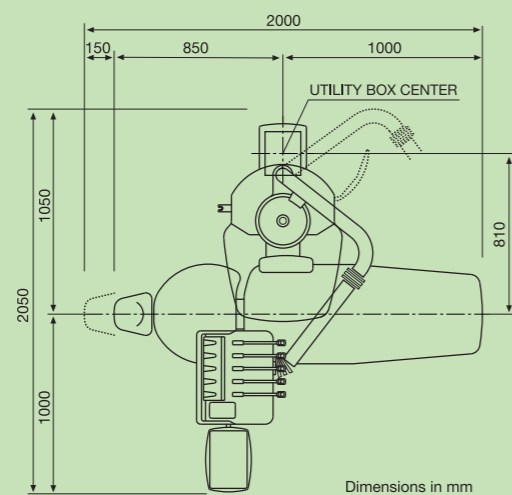
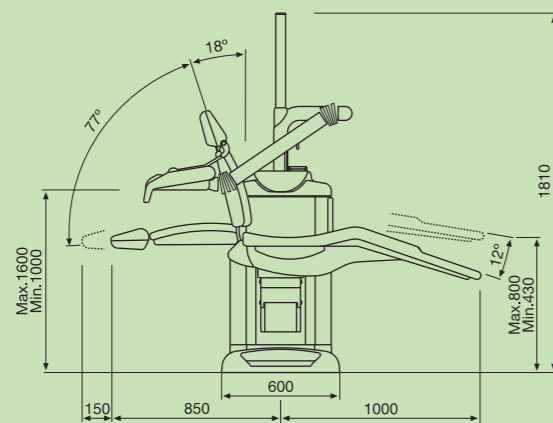

Coral Lux Dental Unit in right handed configuration.

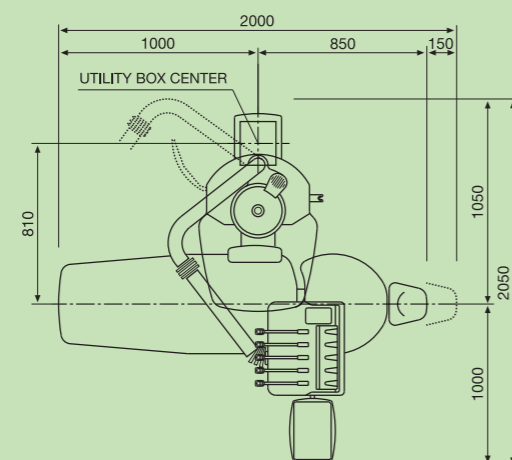

Coral Lux Dental Unit in left handed configuration.

Chair

The chair is perfectly adaptable to the patient and the particular work to be done.

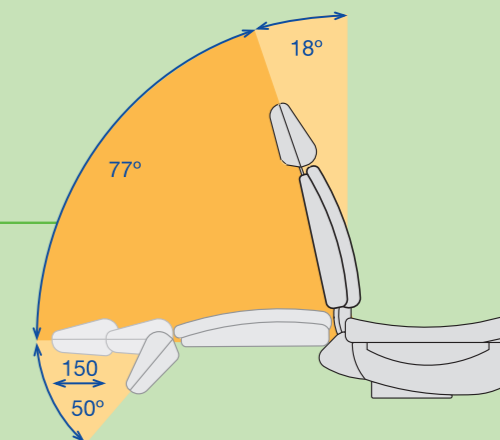

Equipment

The jointed tray arm may be placed in any part of the operating area.

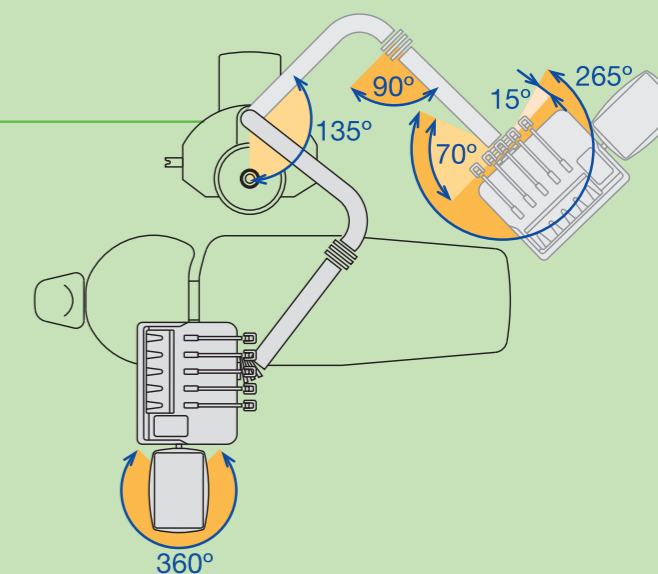

Dental unit
Coral air

Technical information

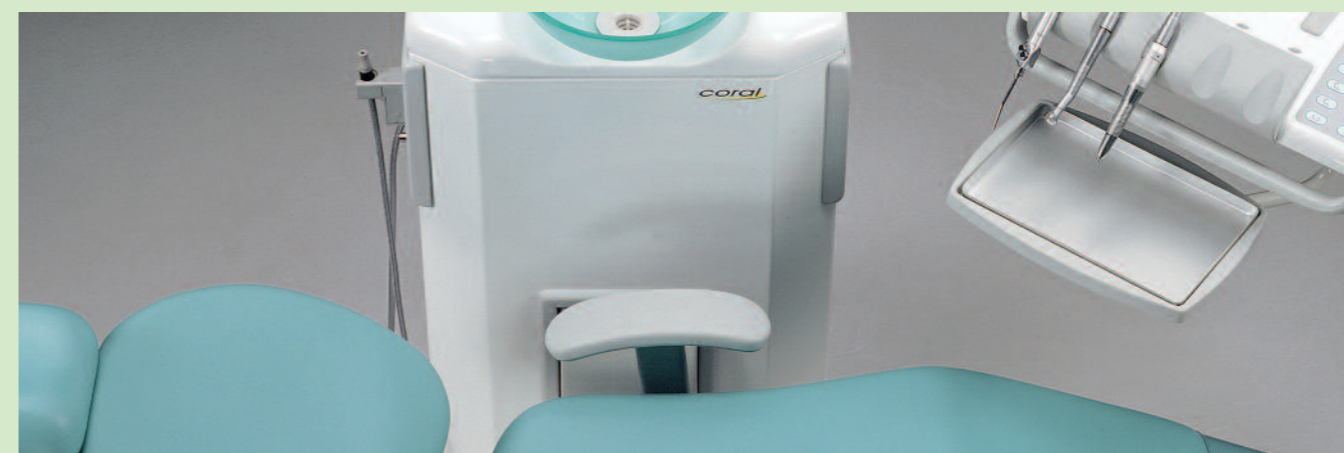
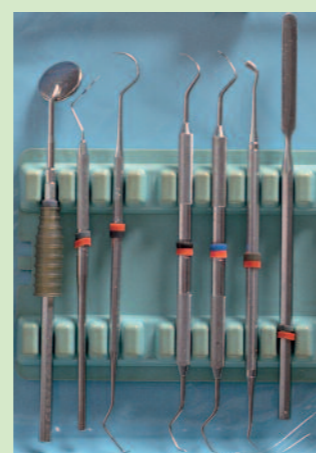



FEDESA

NUEVA FEDESA, S.A.

Avda. Madrid, nº 45
28500 ARGANDA DEL REY (Madrid) España
Tel.: 34 - 91 871 23 83. Fax: 34 - 91 871 64 88
e-mail: fedesa@fedesa.com - www.fedesa.com