



Philips Consumer Lifestyle

# Service Manual

## PRODUCT INFORMATION

- This product meets the requirements regarding interference suppression on radio and TV.
- After the product has been repaired, it should function properly and has to meet the safety requirements as officially laid down at this moment.

## TECHNICAL INFORMATION

- Colour : Cardinal Red
- Power consumption : 2000 W (IEC) 230V
- Maximum Air displacement : 47 l/s
- Vacuum : 340 mbar / 34.0 kPa
- Type number dustbag : FC8023
- Duststorage capacity : 4 L
- Cord length : 9 m
- Filter system : Classic S-Bag long performance : 3 layer permanent motor protection filter : Ultra clean air washable HEPA13 exhaust filter
- Dimensions of cleaner : 472 x 324 x 276 mm
- Dimensions of packaging : 593 x 393 x 296 mm
- Net weight : 6.3 kg
- SAP coding : FC9174/01

## ACCESSORIES

- Nozzle : Tri-Active all purpose nozzle
- Special Nozzle : Turbo Brush Nozzle
- Tubes : Metal lacquered 3-piece telescopic tube
- Accessories : Brush, crevice nozzle and small nozzle
- Accessory storage : Active accessory storage bridge in handgrip
- Coupling : Button coupling

## OPTIONAL (accessories)

- FC8021 : S-bag Classic
- FC8022 : S-bag Clinic
- FC8023 : S-bag Anti-Odour
- FC8031 : Super Clean Air HEPA filter, HEPA12 exhaust filter
- FC8038 : Ultra clean air washable HEPA13 exhaust filter

## DISASSEMBLY- AND RE-ASSEMBLY ADVISE

- Open the appliance, first remove the filter cover (item 22) and then remove the 2 screws (A) of the button assy (item 10).
- The button assy can be removed by lifting up the back of the assy and then pull the assy out of the appliance.
- When the dustcover and the handle have been removed, the electronics, DBFI valve assy, CW-lever and the switch lever can be removed.
- The dustchamber and the backpanel can be removed from the appliance by removing 15 screws (B and C).
- You will require a screwdriver with a 14.5 cm long shank for this. Screwdriver 4322 009 08490 for T15 can be used.
- When the cordwinder has been taken out, the final screw (D) for releasing the lower front from the appliance can be removed.
- When the repair is finished, check whether all functions of the appliance work properly.
- To disassemble the cordwinder, use TORX screwdriver no. T10, which is one of a set consisting of T20; T15; T10; T9; T8; T7 and T6 (code number 4822 395 505145).

## REPAIR INSTRUCTION

- Cotton dustbags, are used in countries in which paper dustbags are not available.
- If the reel half spring unit is replaced, shaft G must be lubricated with **silicone grease**. Do not apply any silicone grease to or spill any grease on terminals (37) or conductors (36).
- The cord winder spring must be tensioned to the maximum level and then be rewound approx. 1.5 turn.
- **Item 14**, air valve, opens to cool the motor if the air displacement is too low or if the airflow is blocked.
- If the function of the electronic control unit is not required, the Triac must be short-circuited in the manner shown in the circuit diagram.
- When the vacuum cleaner is used to suck up fine dust the pores of the dustbag may become clogged, causing the passage of air through the dustbag to become obstructed. As a result, the dustbag-full indicator will indicate that the dustbag needs to be replaced, even though the dustbag is not full at all.

## ELECTRICAL DIAGRAM

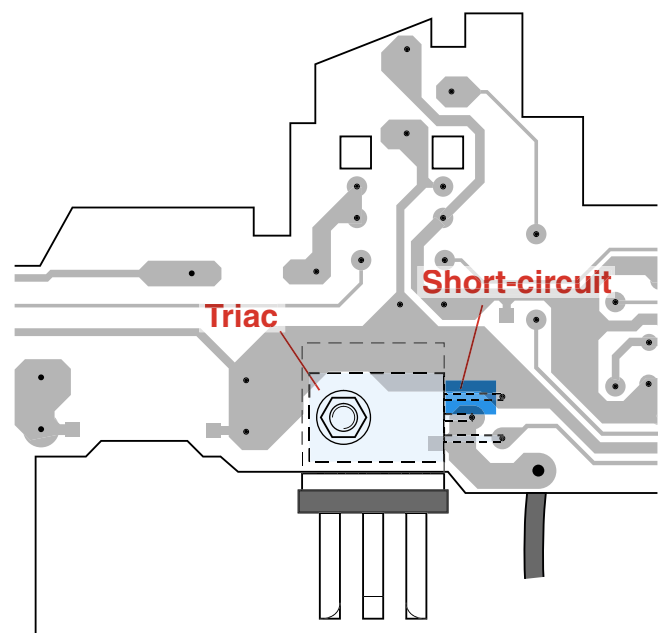
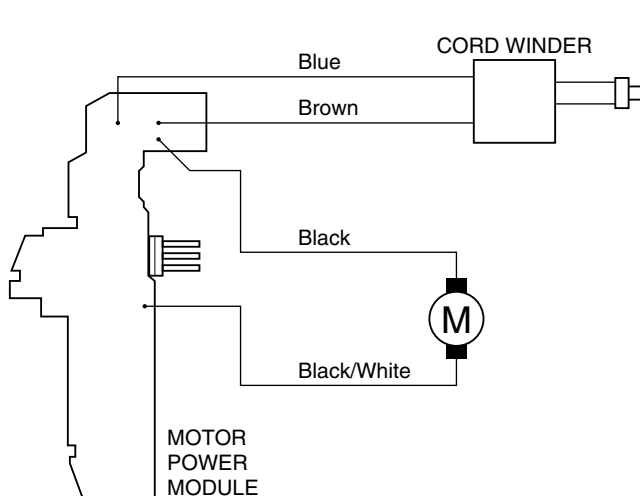

**PARTS LIST**

**FC9174/01 / FC9174/08**

Pos	Service code	Description
1	4322 005 24570	Dustcover / Pr / Cardinal Red
2	4322 005 17600	Dustcover lock assy
3	4322 000 67810	DB detector spring
4	4322 003 24790	DB detector / LB / Cool grey
5	4322 003 24780	CCC (DB holder)
6	4322 000 37300	Triple inletfilter
7	4322 003 33280	Inlet grille / Blue
8	4322 003 24650	Dustchamber / Black
9	4322 009 09570	Handle performer / Cardinal Red
10	4322 009 09610	Button panel assy / Pr / Card. Red
11	4322 003 24810	Cord winder lever
12	4322 003 27910	Control wheel / Select Grey
13	4322 006 22750	PCB assy 220-240 V 50/60 Hz
14	4322 005 20580	DBFI/Valve assy / Sp.v.
15	4341 003 02390	Switch lever
16	4322 003 24620	Back panel / Black
17	4322 003 24720	Cord outlet / Black
18	4322 003 24600	Lower / LB / Back
19	4322 003 27920	Lower front / Wine red
20	4322 005 17010	Caster assy / Select grey
21	4322 003 24690	Filter cover lock / Select grey
22	4322 005 20110	Filter cover / Cardinal Red
23	4322 004 93340	HEPA13 washable exhaust filter
24	4322 001 74110	Exhaust sealing / Blue
25	4322 000 38790	Silencer 4 wall backpanel
26	4322 003 25460	S-Class H-sealing
27	4322 000 38670	Silencer 1 wall
28	4322 000 38770	Silencer 2 bottom
29	4322 003 23880	Motorhousing top inside
30	4322 001 73400	Bufferring front ANS-Atlas

Pos	Service code	Description
31	4322 009 09430	Motor Domel 1761 220 - 240 V
32	4322 000 38820	Silencer 3 compas
33	4322 001 73520	Motor buffer back green
34	4322 003 23870	Motor housing bottom ANS
35	4322 009 09440	Reel half spring unit (L = 9 m)
36	4322 009 09450	Reel half contact unit
37	4322 009 09460	Contact ring plate
38	4322 006 07410	U.K. / H.K. L = 9.3 m
39	4322 006 07390	Euro 4.8 mm pins L = 9.3 m
40	4322 003 18850	C. Bend B1
41	4322 005 12760	LC Swivel assy
42	4322 005 23060	C. Bend B1 / Hose / Swivel assy / Silver steel Nickelfree
42a	4322 004 23360	Hose assy / Silver Steel
43	4322 007 16000	Leaf spring assy
44	4322 004 23890	3-Piece Telescopic tube assy Nickelfree
45	4322 001 99120	Coupling bush
46	4322 007 31650	Coupling spring
47	4322 004 22570	Plumeau assy
48	4322 003 18870	Crevice nozzle
49	4322 005 12530	Accessory bridge assy
50	4322 004 22560	Small nozzle
51	4341 004 20840	Tri-Active nozzle, stand.
52	4322 003 26030	Motor bracket
53	4322 004 23380	Turbo Nozzle

EXPLODED VIEW

FC9174/01 / FC9174/08

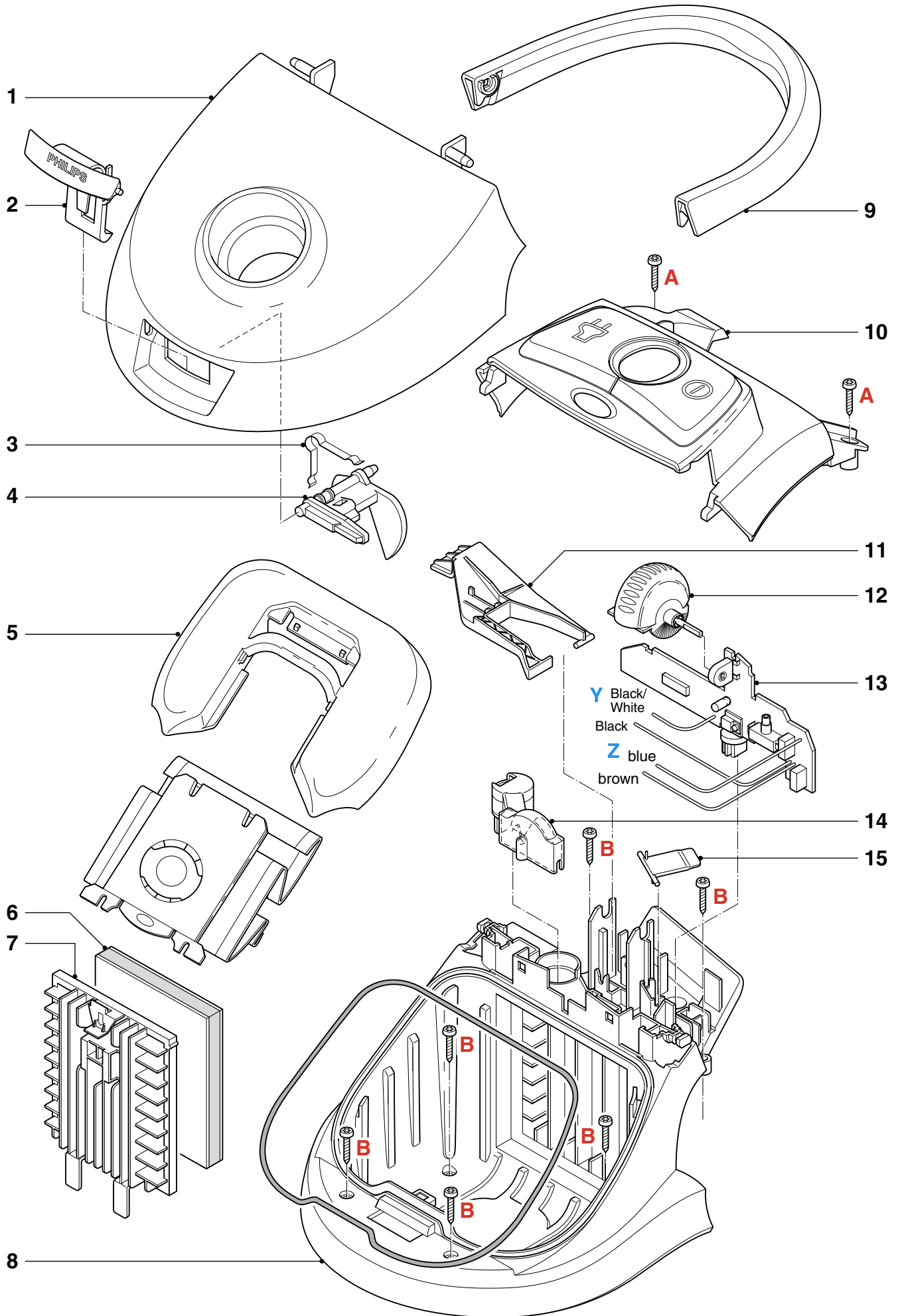

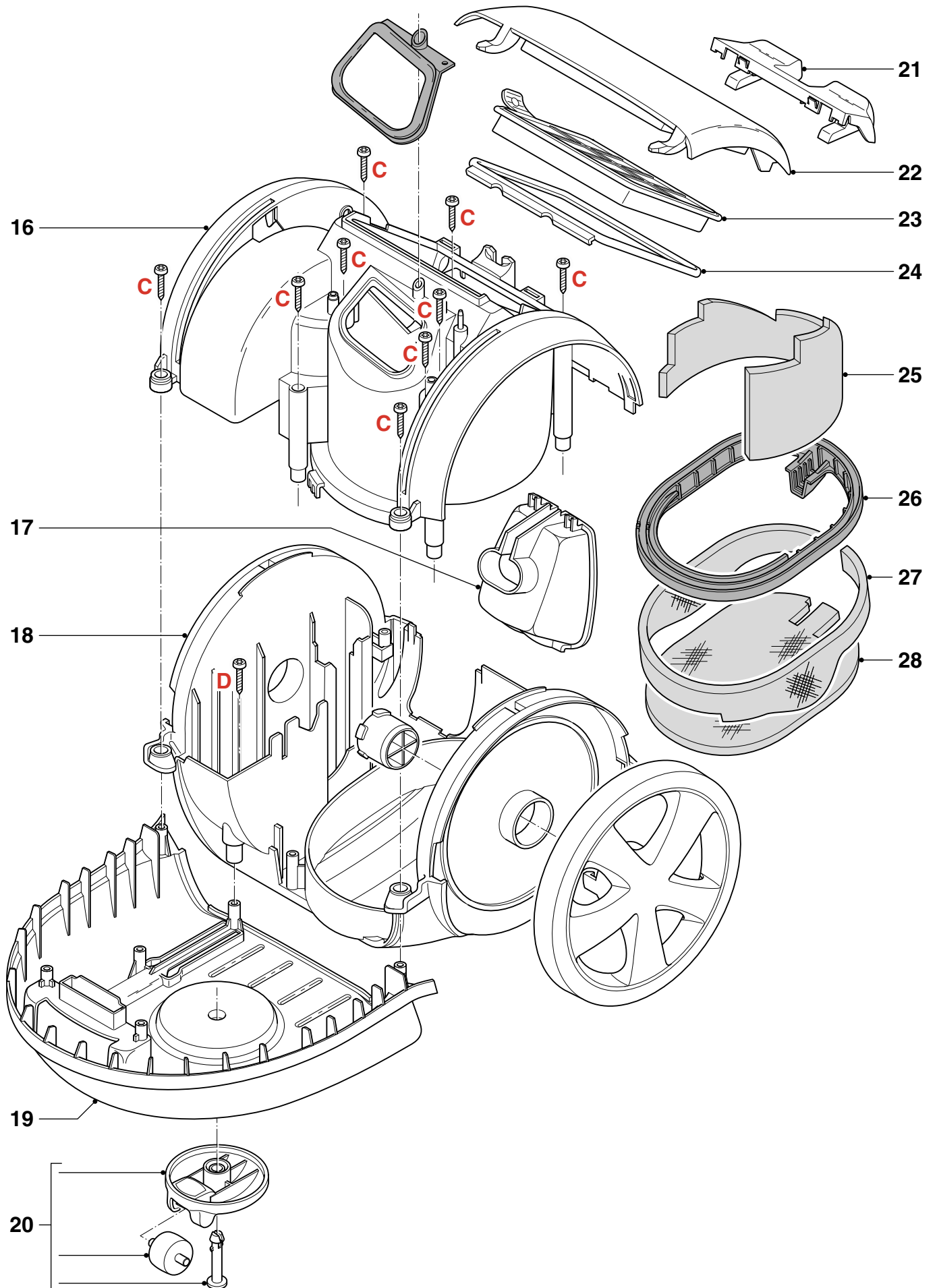

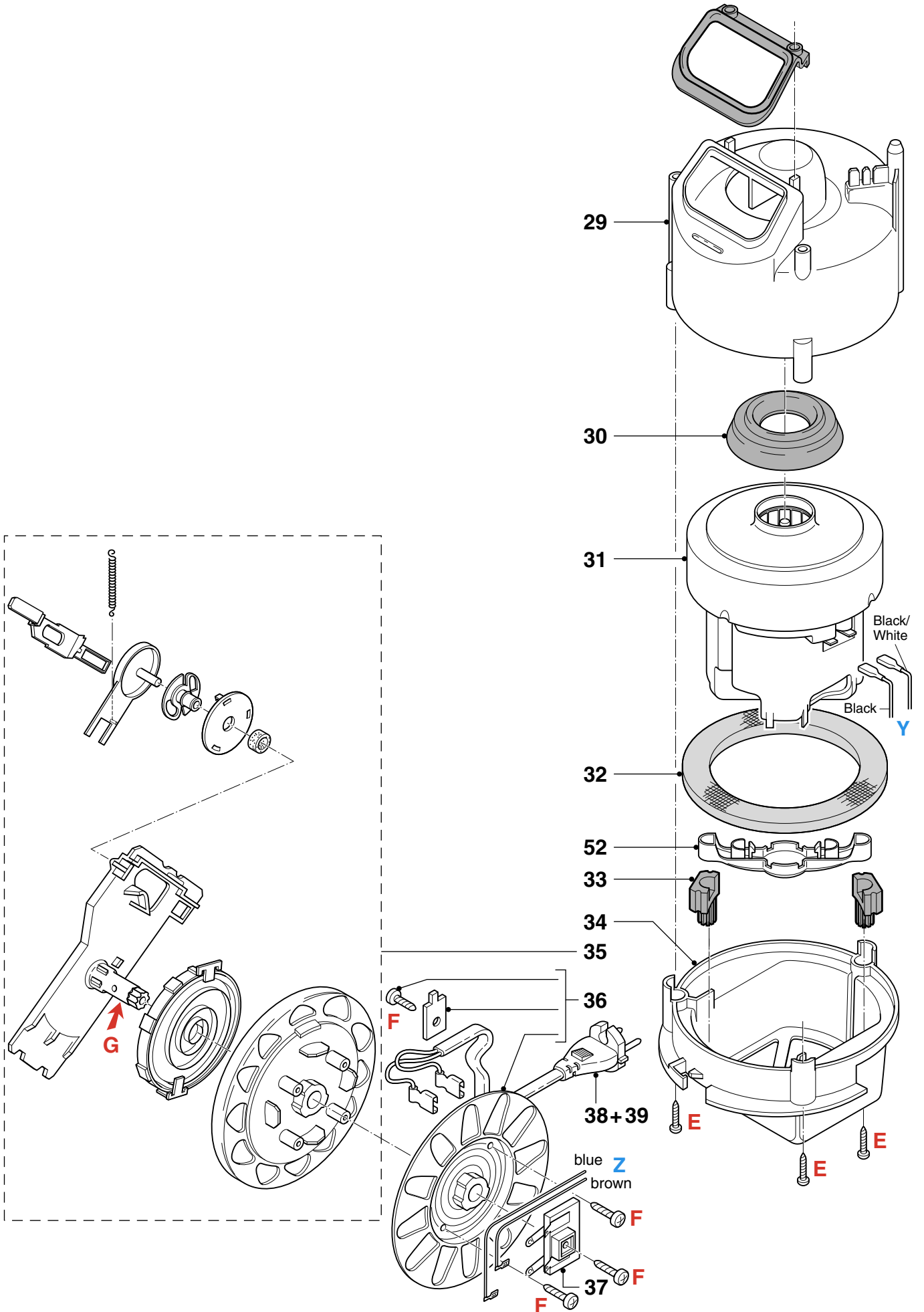

**EXPLODED VIEW**

**FC9174/01 / FC9174/08**

