

HITACHI

SC

No. 0016E

C 21-F880S/SN/SNT

SERVICE MANUAL

PAL/SECAM/NTSC

3P31

Chassis



CAUTION: Before servicing this chassis, it is important that the service technician read the "Important Safety Note" in this Service Manual.

SPECIFICATIONS AND PARTS ARE SUBJECT TO CHANGE FOR IMPROVEMENT

COLOUR TELEVISION

February 2006 Digital Media Systems Group, Hitachi Asia Ltd.

CONTENTS

Important Safety Note-----	2
Technical Specification-----	3
Chassis Block Diagram-----	5
IC Block Diagram -----	6
Transistor Mark -----	12
PCB Top/Bottom layer -----	13
Service Adjustments -----	16
Purity and Convergence Adjustment-----	24
Operation Instructions-----	25
Input and Output Terminals-----	27
Remote Controller Functions-----	28
Mechanical Assembly-----	37
Replacement Parts List-----	38
Electrical Parts List (For Reference Only)-----	39
Mechanical Parts List(For Reference Only)-----	53
3P31 Schematic Diagram-----	55

IMPORTANT SAFETY NOTE

Maintenance and repair of this TV should be done by qualified service personnel only when servicing the high voltage system, remove static charge from it by discharging the picture tube (2nd anode lead) to the dag coating (picture tube grounding lead).

SAFETY PRECAUTIONS

1. An isolation transformer should be used to supply power to the TV during servicing on the primary of the converter transformer of the set.
2. Read and comply with all caution and safety related notes on the back cover, inside the TV, on the PCBs and the picture tube.
3. When replacing a chassis in the cabinet, always be certain that all the protective devices are installed properly (e.g. control knobs, adjustment covers or shields, barriers, isolation resistor-capacitor networks etc.). Before returning the television to the customer, the service technician must ensure that it is completely safe to operate.

X-RADIATION PRECAUTION

The primary source of X-RADIATION in television receiver is the picture tube. The picture tube is specially constructed to limit X-RADIATION emissions. For continued X-RADIATION protection, the replacement tube must be the same type as the original including suffix letter. Excessive high voltage may produce potentially hazardous X-RADIATION. To avoid such hazards, the high voltage must be maintained within specified limit. Refer to this service manual on the high voltage adjustment for the specific high voltage limit. If high voltage exceeds the limits, take necessary corrective action. Carefully follow the instructions for +B volt power supply adjustment, and high voltage check to maintain the high voltage within the specified limits.

PRODUCT SAFETY NOTICE

Maintenance and repair of this TV should be done by qualified service personnel only. Critical parts that have special safety characteristics are identified by a  in the replacement parts list or the schematic diagrams. Use of any substitute replacement part that does not have the same safety characteristics as the recommended replacement part in the parts list might create shock, fire and/or other hazards. Please do not degrade the safety of this TV through improper servicing.

TECHNICAL SPECIFICATION

FEATURES:

- FULL MULTI SYSTEM: RF--PAL BG/DK/I,SECAM BG/DK/K1,NTSC M VIDEO--NTSC50,NTSC3.58/4.43,PAL60,SECAM60
- FREQUENCY SYNTHESISED TUNING SYSTEM
- FULL AUTO PROGRAM
- RATING VOLTAGE AC 100-240V 50/60Hz
- 200 PROGRAMS MEMORY
- 180 MINUTES SLEEP TIMER
- 1 AV INPUT+1 SIDE AV+S-VIDEO INPUT
- 1 YUV INPUT
- 1 AV (MONITOR) OUTPUT SOCKET FOR VCR RECORDING
- 10 PAGES TELETEXT (OPTIONAL) *
- NICAM/A2 STEREO (OPTIONAL) *
- 1 GAME
- SURROUND
- AV STEREO
- CLOCK
- CHILD LOCK
- BLUE BACK
- BLACK STRETCH
- PICTURE MODE: USER,SOFT, STANDARD, RICH
- SOUND MODE: USER ,SPEECH ,MUSIC,THEATER

* Only applicable to some model only.

GENERAL SPECIFICATION:

1	POWER CONSUMPTION:	MAX:	90W
		NORMAL:	75W
	STANDBY POWER CONSUMPTION:		≤5W
2	RECEIVE SYSTEM:		B/G, D/K, I, M
3	COLOUR SYSTEM:		PAL/ SECAM/ NTSC
4	VISION INTERMEDIATE FREQUENCY :		38.9MHz
5	INTER-CARRIER FREQUENCY:		4.5 MHz (M)
			5.5 MHz (B/G)
			6.0 MHz (I)
			6.5 MHz (D/K)
			5.85 MHz (NICAM B/G,D/K)
			6.55 MHz (NICAM I)
			5.74MHz(GERMAN STEREO)
6	CHROMA IF FREQUENCY PAL/NTSC:		34.47/35.32 MHz
7	ANTENNA TYPE:		75 OHM DIN TYPE
8	CHANNELS RECEIVING:	VHF-1	A0;E2-E4;S1-S9 44.25-161.25MHz
		VHF-2	S10-S41; E5-E12 168.25-463.25MHz
		UHF	E 21-E69 CH 471.25-863.25MHz
9	TUNING SYSTEM:		FS TUNING
10	AV IN/OUT:		1 AV IN+1 AV OUT; 1 SIDE AV INPUT 1 S-VIDEO IN; 1YUV IN

TECHNICAL SPECIFICATION

- 10 AV IN/OUT:** 1 AV IN+1 AV OUT; 1 SIDE AV INPUT;
1 S-VIDEO IN; 1YUV IN
- 11 OSD LANGUAGE:**
OPTION 1: ENGLISH / CHINESE(SIMPLE)/ CHINESE (TRADITIONAL)/MALAY
OPTION 2: ENGLISH/ARABIC/RUSSIAN/FRENCH/THAI/MALAY
- 12 AUDIO OUTPUT POWER:** 5W+5W (1KHz, 0.5V INPUT, 10%THD)
- 13 SAFETY STANDARD:** CB/ EMC
- 14 LED INDICATORS:** POWER ON
- 15 HAND SET TYPE :** KF5000A
- 16 HAND SET POWER SUPPLY :** BATTERY 3V (UM-3/R6/AAA) x2
- 17 COLOUR PICTURE TUBE:** 21" 90 DEGREE TUBE
- 18 MAX REMOTE CONTROL DISTANCE:** 5 m

CHASSIS BLOCK DIAGRAM

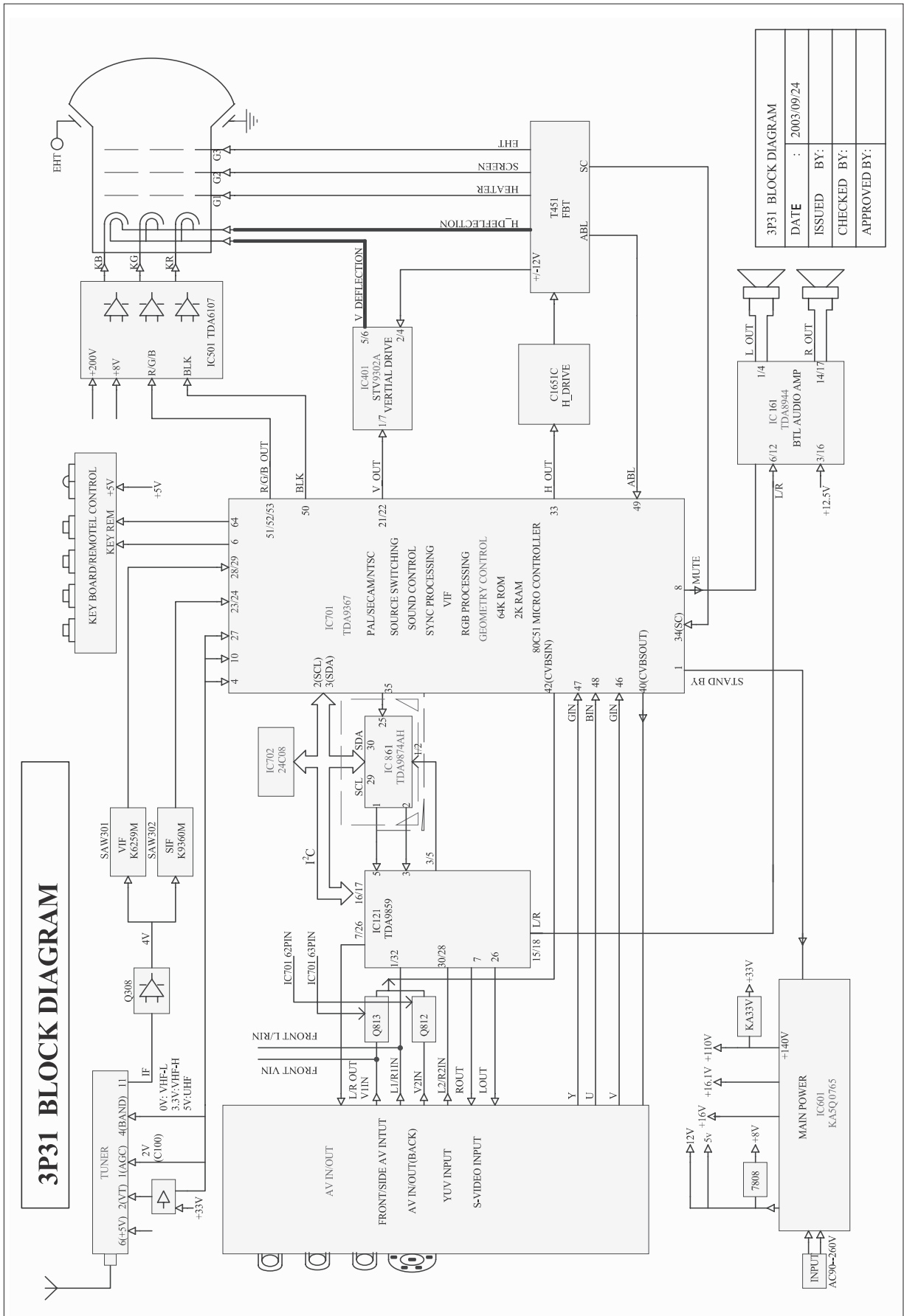

IC BLOCK DIAGRAM

IC 121 (Universal HI-FI Audio Processor) TDA9859

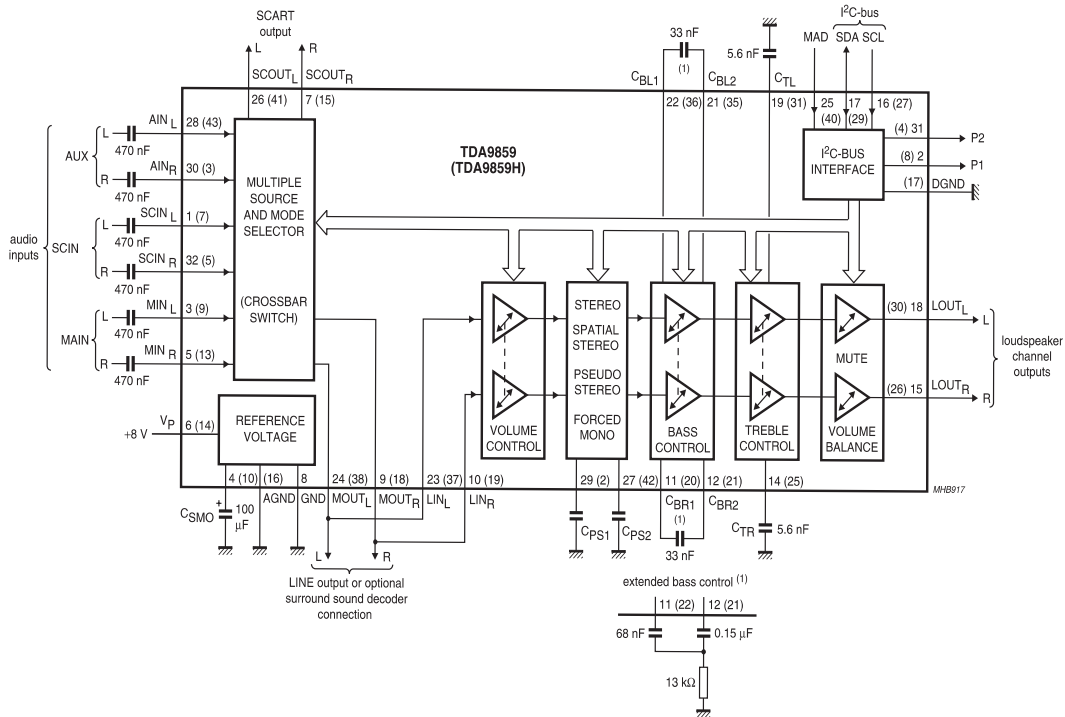

IC 161 (BTL Audio Amplifier) TDA8944J

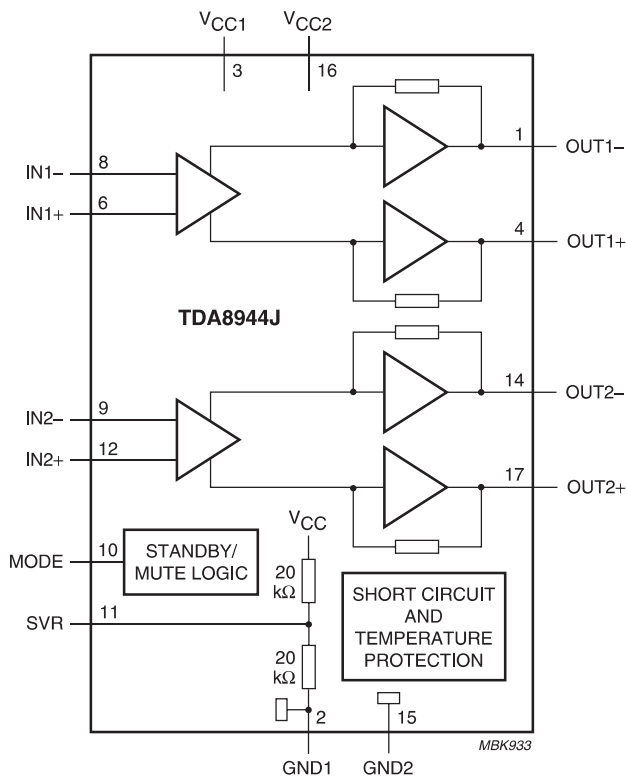

IC BLOCK DIAGRAM

IC 401 (Vertical Deflection Booster) STV9302A

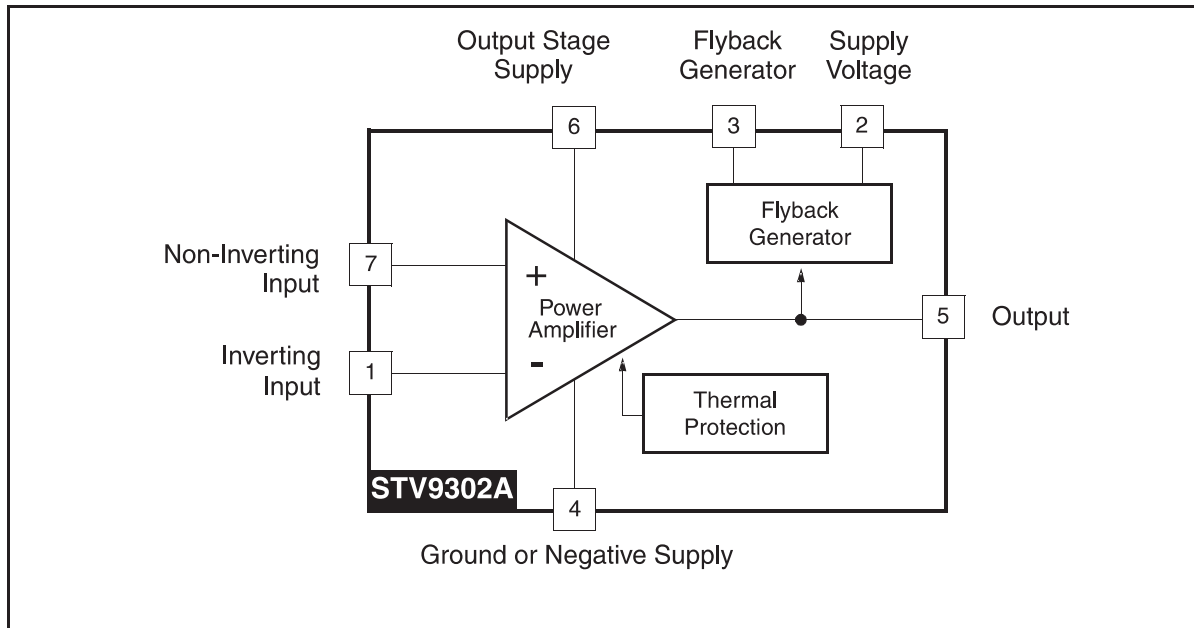

IC BLOCK DIAGRAM

IC 501 (Video Output Amplifier) TDA6107Q

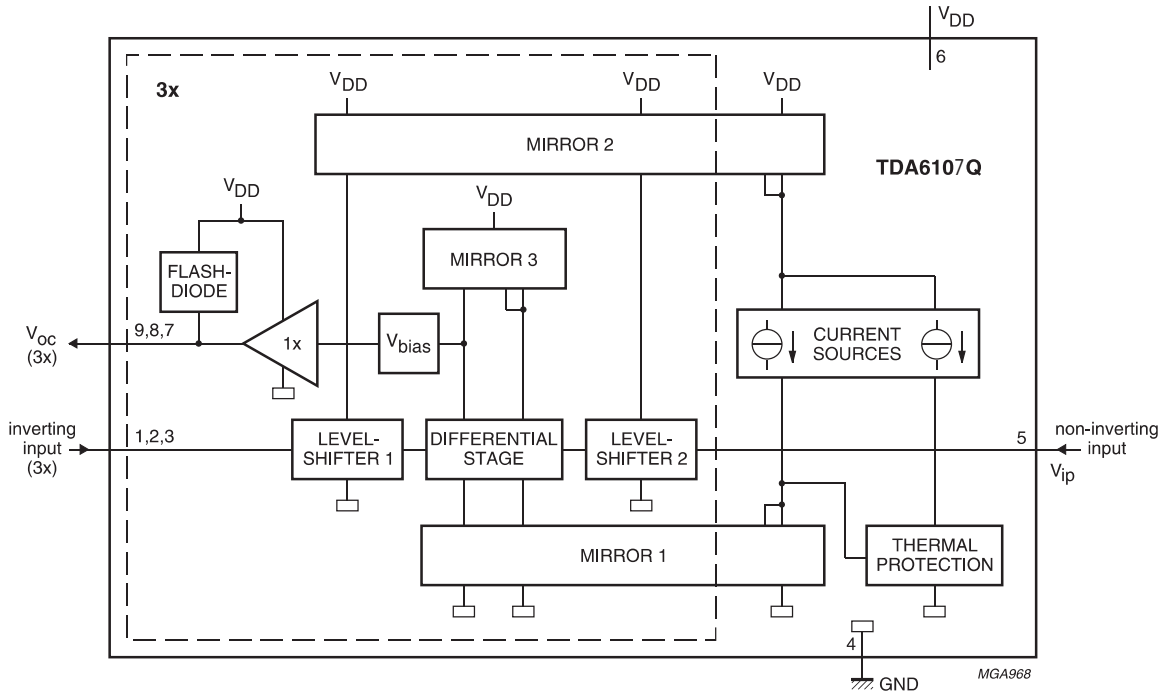

IC 601 (Power Switch) KA5Q0765RTH

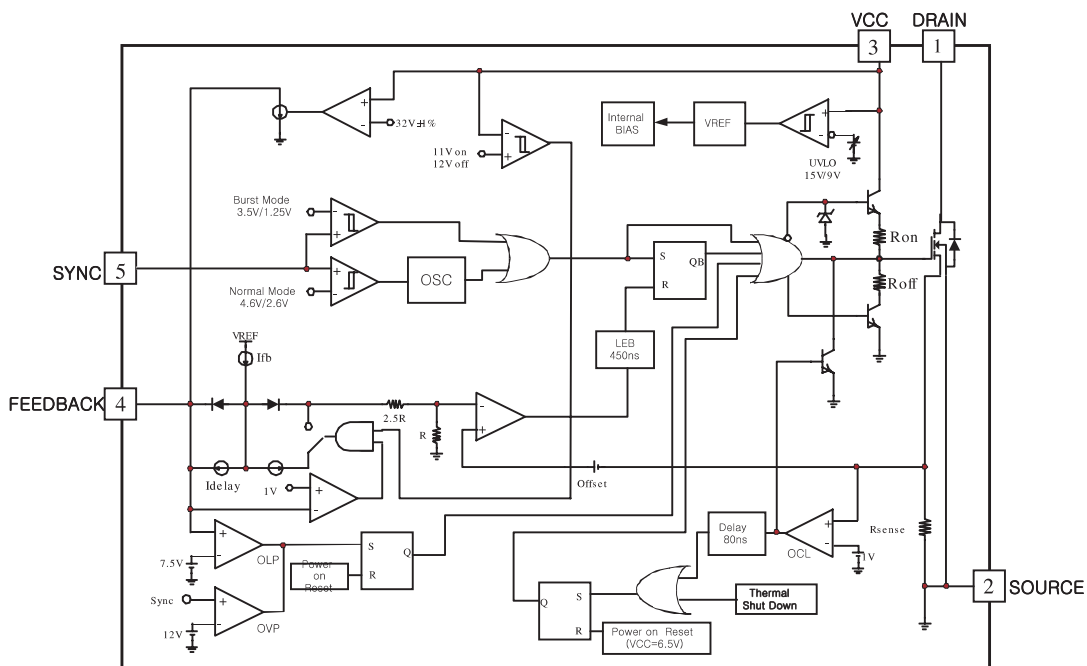

IC BLOCK DIAGRAM

IC 602 (Photo Transistor) TLP621

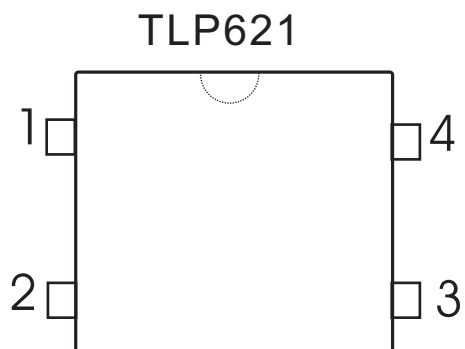

- 1: ANODE
- 2: CATHODE
- 3: EMITTER
- 4: COLLECTOR

IC 653 & IC 181 & IC 652 (Regulators) L7800 Series

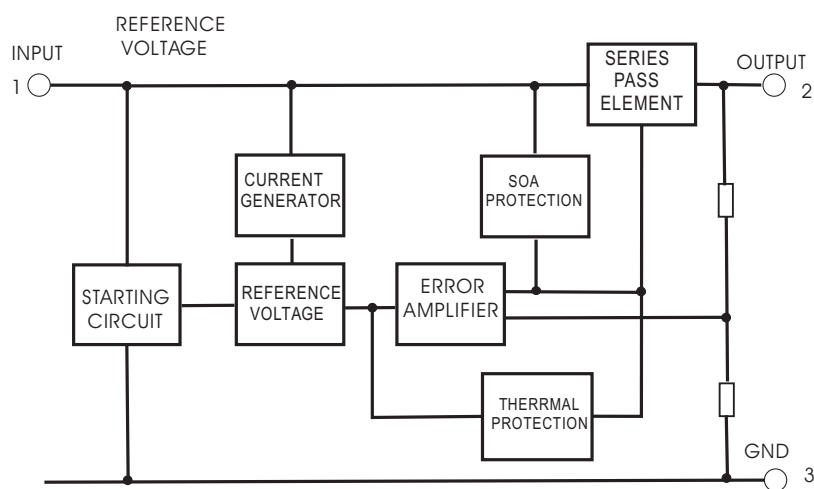

IC BLOCK DIAGRAM

IC 701 (TV Signal Processor-Teletext) TDA93XXPS/N2/5I

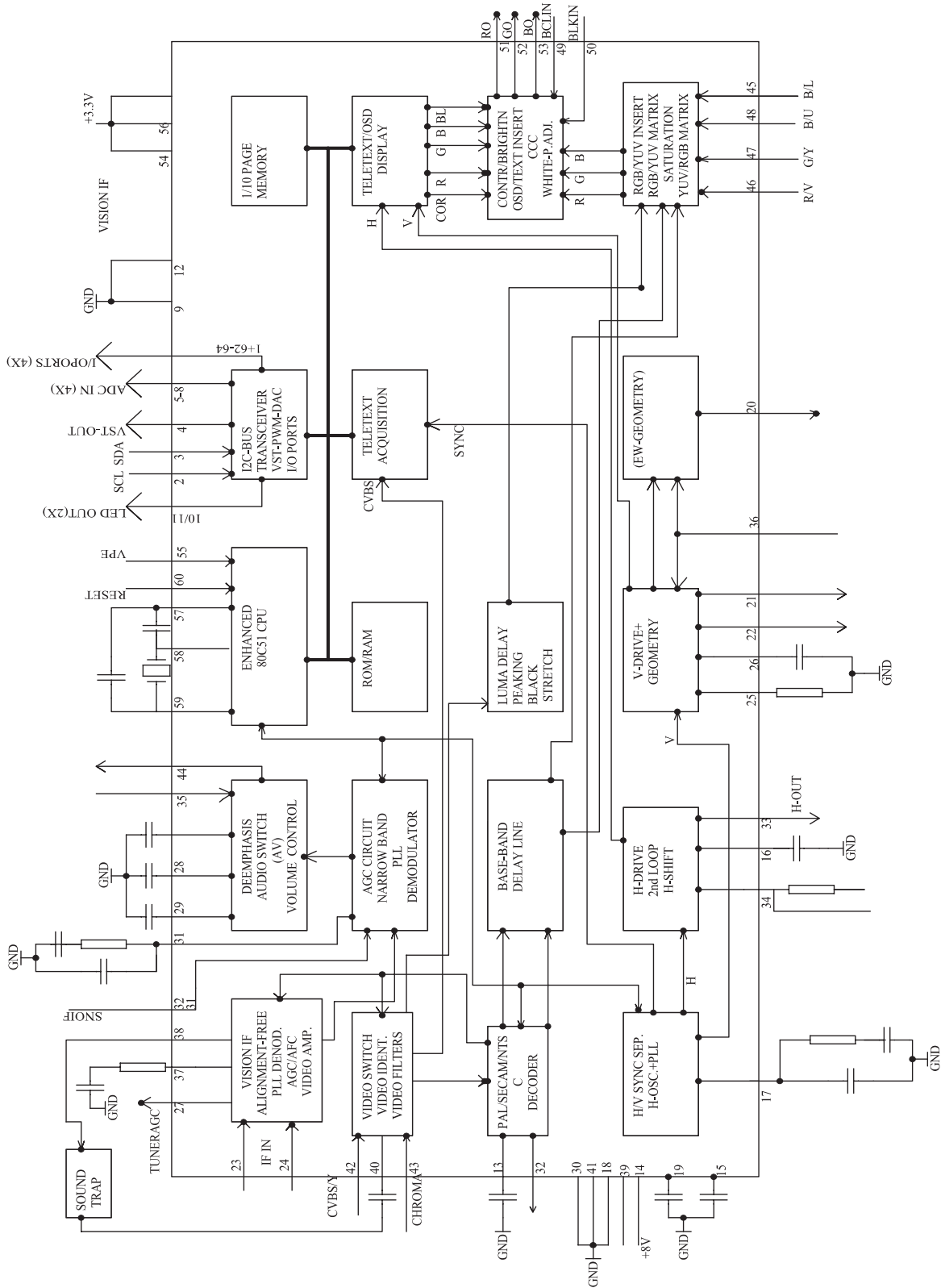

IC BLOCK DIAGRAM

IC 861 (Digital TV Sound Demodulator/Decoder) TDA9874AH

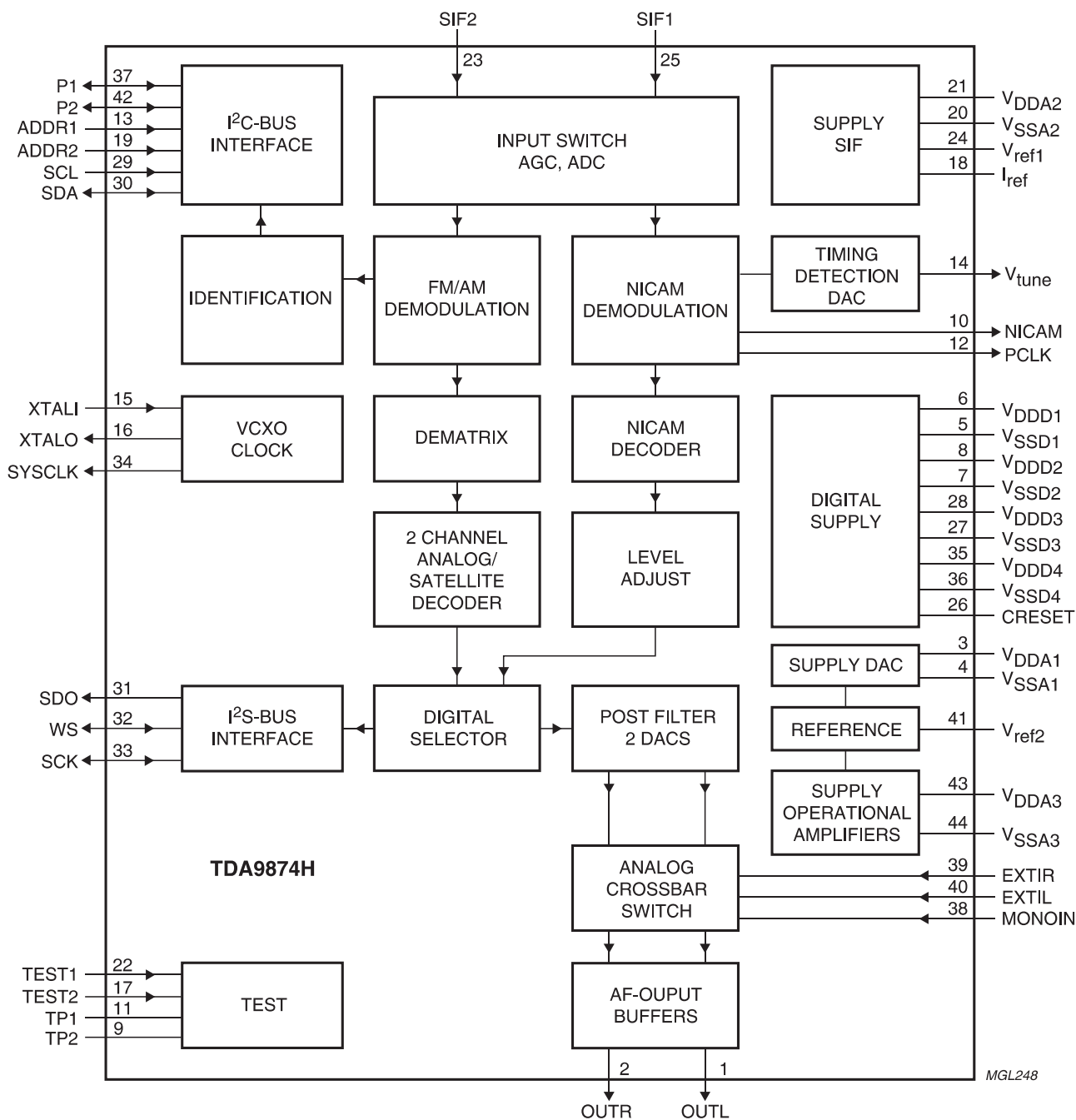

TRANSISTOR MARK

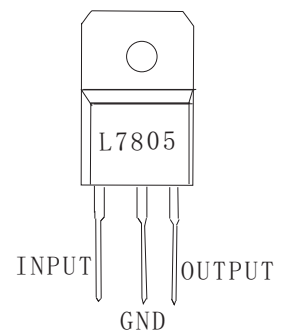
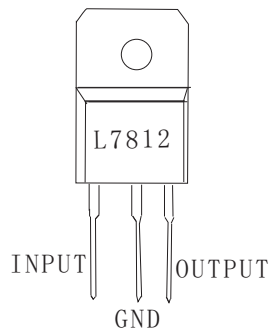
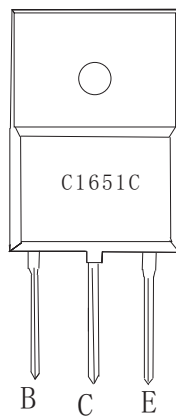
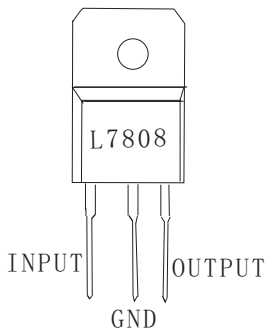
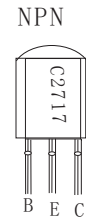
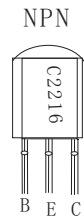
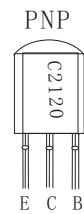
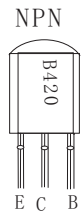
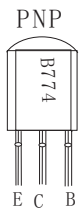
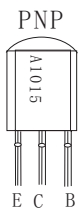
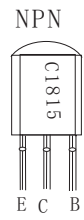
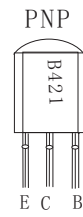
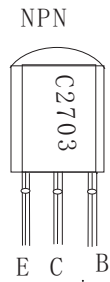
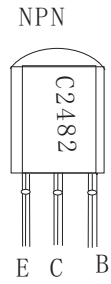
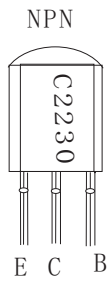
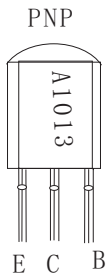
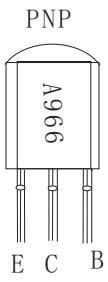

MAIN PCB TOP LAYER

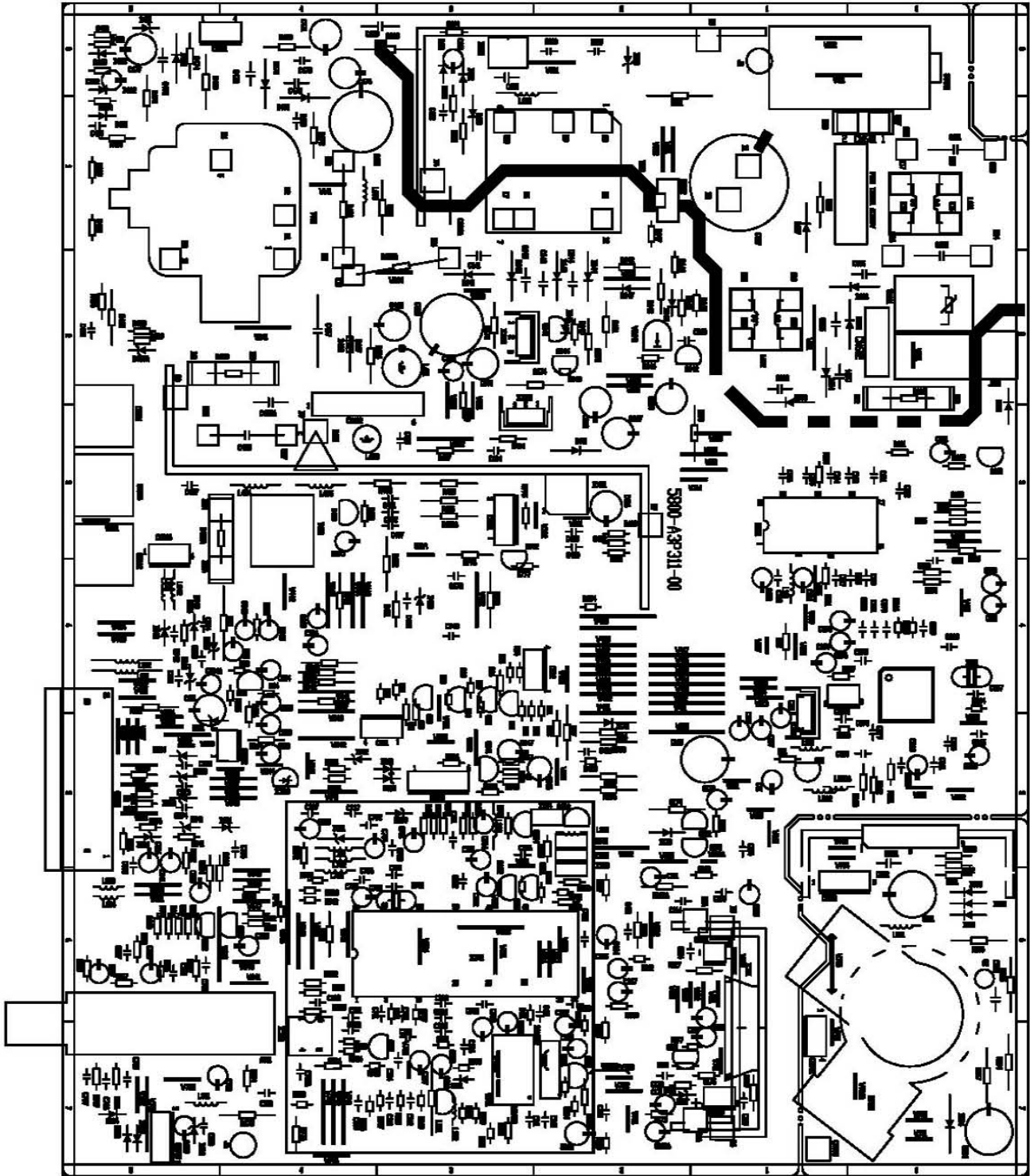

MAIN PCB BOTTOM LAYER

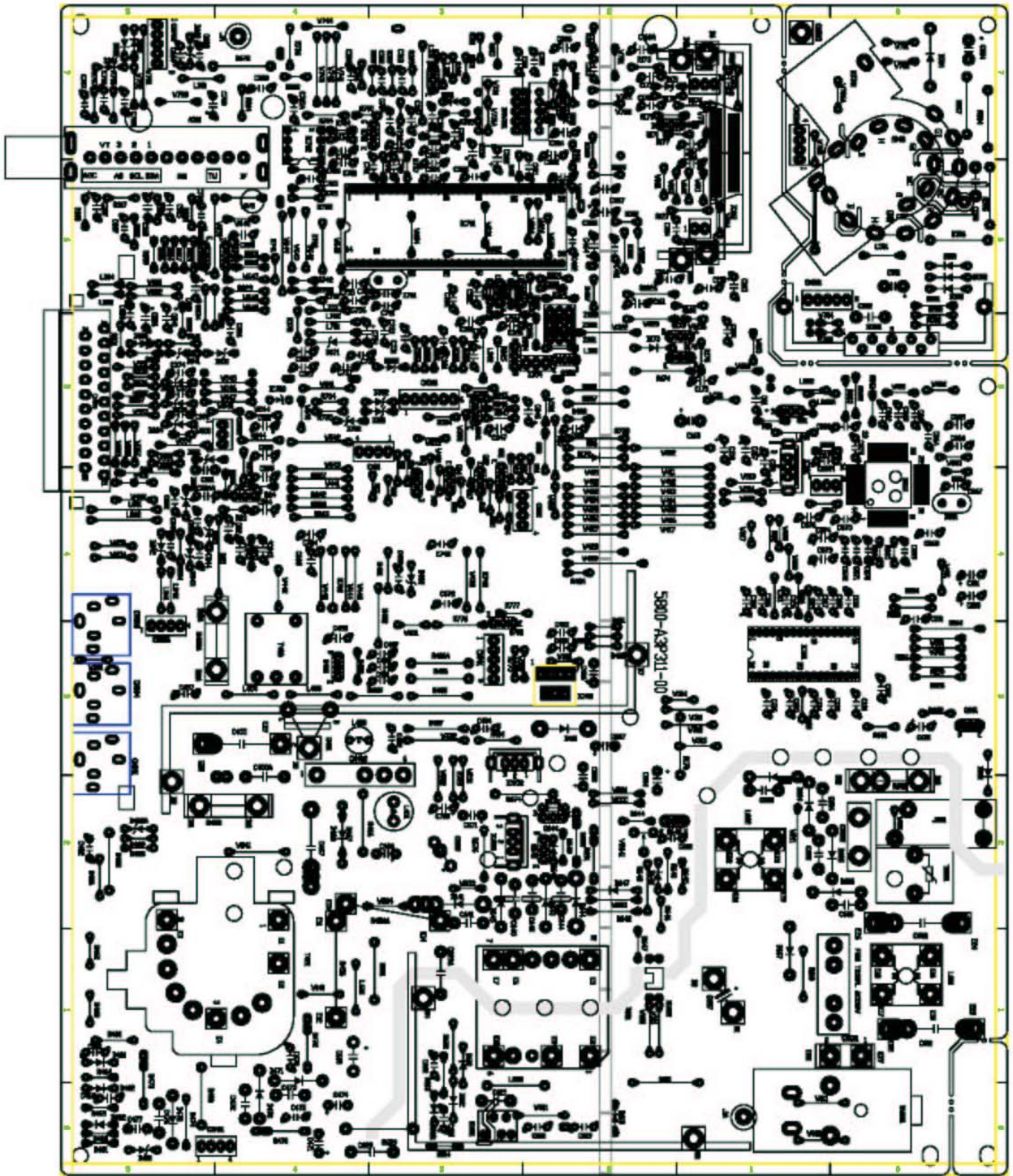

AV TERMINALS PCB LAYOUT

Side AV Terminals PCB Layout

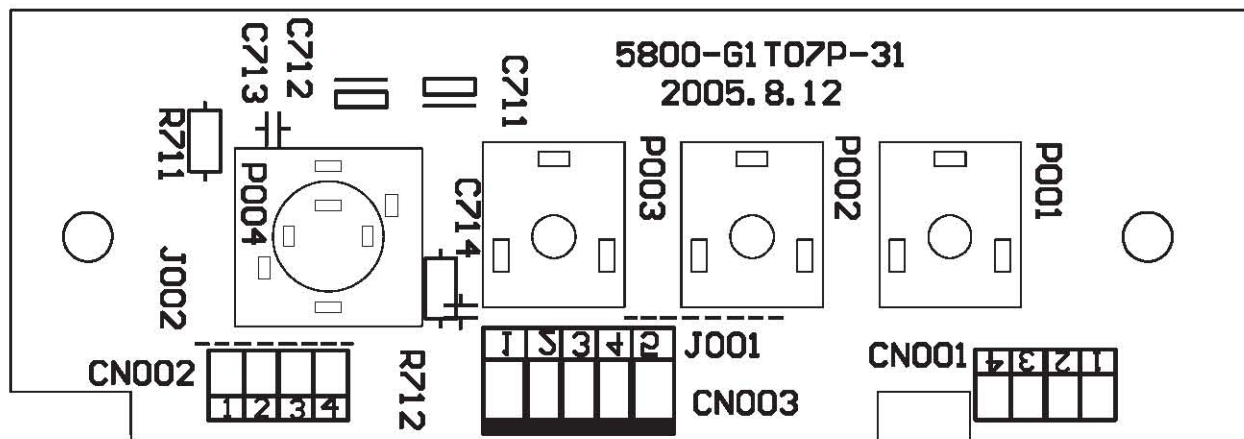

Control Panel PCB Layout

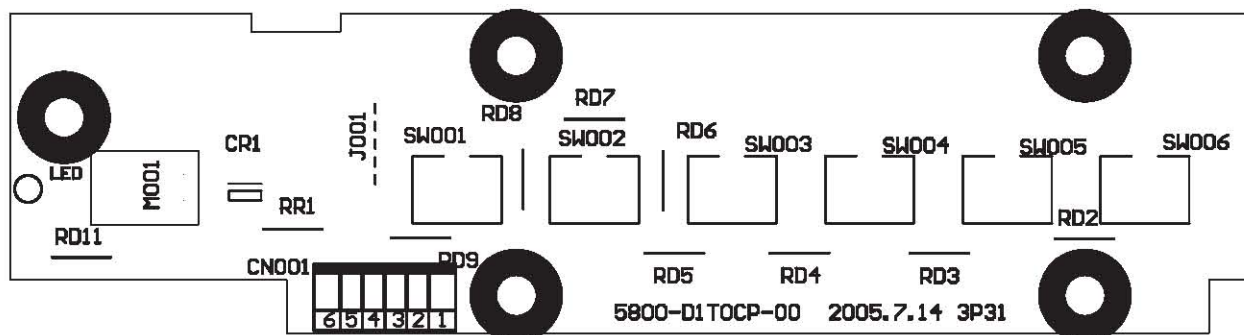

SERVICE ADJUSTMENTS

ALIGNMENT INSTRUCTION (3P31)

1. Before Servicing The TV Set

- 1-1 The main power is 100~240V 50/60Hz . Please be careful when you are servicing.
- 1-2 Do not short any two soldering points, and do not touch any components unnecessary.
- 1-3 Please disconnect the power plug from the wall outlet before servicing.
- 1-4 For safety reasons, all components replaced should be identical with the parts list.
- 1-5 Before alignment, ensure the TV set has heat run for at least 30 minutes and degauss the CRT thoroughly with demagnetizer.
- 1-6 The data of EEPROM must be stored before the adjustment for main chassis.

2. Tools And Equipment For Adjustment

- 2-1 Small Screwdriver Without Inductance
- 2-2 Pattern Generator
- 2-3 DC Regulated Power Supply
- 2-4 Digital Voltmeter
- 2-5 Sweep Signal Generator
- 2-6 20MHz 2-channel Oscilloscope

3. Power Adjustment

Connect a 100W bulb across C616 and AC 200V power to CN601. If the bulb lights up, the voltage is normal and power is ok, please proceed servicing.

SERVICE ADJUSTMENTS

GENERAL ADJUSTMENT

1 Enter Service Mode

- 1-1 Press **CLOCK** , **PIC. MODE** , **SLEEP** buttons continuously on the remote control to enter service mode.
- 1-2 Press 0-9 numeric buttons to enter service menu.
- 1-3 Select the item using the **P+** and **P-** buttons and adjust using the  and  buttons.
- 1-4 Press **RECALL** button to exit service mode.

2 Focus Adjustment

- 2-1 Receive monoscope pattern.
- 2-2 Press **PIC.MODE** button to set picture in DYNAMIC mode.
- 2-3 Adjust the focus knob of FBT to get the clearest picture.

3 Screen Voltage Adjustment

- 3-1 Press **PIC. MODE** button to set picture in STANDARD mode at no signal input.
- 3-2 Press **CLOCK** , **PIC. MODE** , **SLEEP** buttons continuously to enter service mode.
- 3-3 Press 0 button and a horizontal line will display on the screen.
- 3-4 Adjust the screen knob of FBT so that the horizontal line is just visible.
- 3-5 Press other buttons to return to normal operation.

4 Vertical Size , Pin Cushion And Horizontal Center Adjustment (Direct Number Button 2 And 1)

- 4-1 Receive 50Hz crosshatch pattern. Press **PIC. MODE** button to set picture in STANDARD mode. Adjust 5VSL to obtain half of the crosshatch. Adjust 5SCL to obtain the picture's best vertical pin cushion. Adjust 5VSH to obtain the picture's vertical centre. Adjust 5RGH to obtain the picture's horizontal centre.
- 4-2 Receive 50Hz monoscope pattern. Press **PIC. MODE** button to set picture in STANDARD mode. Adjust 5VAM to obtain the picture's vertical overscan at more than 90% in service Mode. Adjust 5RGH to obtain picture horizontal center position.

Item	Display String
Vertical slope 50Hz	5VSL
Vertical shift 50Hz	5VSH
Vertical amplitude 50Hz	5VAM
S-correction 50Hz	5SCL
Horizontal shift 50Hz	5RGH

SERVICE ADJUSTMENTS

4-3 Receive 60Hz crosshatch pattern. Press **PIC. MODE** button to set picture in STANDARD mode. Adjust 6VSL to obtain half of the crosshatch. Adjust 6SCL to obtain the picture's best vertical pin cushion. Adjust 6VSH to obtain the picture's vertical center. Adjust 6RGH to obtain picture's horizontal centre.

4-4 Receive 60Hz monoscope pattern. Press **PIC. MODE** button to set picture in STANDARD mode. Adjust 6VAM to obtain the picture's vertical redisplay ratio at more than 90% in service Mode. Adjust 6RGH to obtain picture horizontal center position.

Item	Display String
Vertical slope 60Hz	6VSL
Vertical shift 60Hz	6VSH
Vertical amplitude 60Hz	6VAM
S-correction 60Hz	6SCL
Horizontal shift 60Hz	6RGH

5 OSD Position Adjustment

5-1 Menu OSD position adjustment :

Receive 50/60 Hz crosshatch pattern. Press **PIC. MODE** button to set picture in STANDARD mode. Press number button 2 in service mode, adjust 5VOF/6VOF and HOF item to obtain menu OSD at the center of CRT screen.

5-2 LOGO position adjustment :

Receive 50/60 Hz crosshatch pattern. Press **PIC. MODE** button to set picture in STANDARD mode. Press number button 7 in service mode, adjust XMIN, XMAX, YMIN, and YMAX item to obtain LOGO at the center up to 1/3 of CRT screen.

5-3 TELETEXT OSD position adjustment :

Receive 50/60 Hz TELETEXT signal. Press **PIC. MODE** button to set picture in STANDARD mode. Press number button 7 in service mode, adjust TXMI and 5TYM/6TYM item to obtain TELETEXT at the center of CRT screen.

6 White Balance Adjustment (Applied in factory) (Direct Number Button 3)

6-1 Normally, this TV can auto adjust white balance, but for some CRT, maybe there is a need to adjust white balance manually.

6-2 Set BRIGHTNESS and CONTRAST at normal status.

6-3 Receive GREY SCALE and enter service mode.

6-4 Press number button 3 and set WPR at 31.

6-5 Adjust WPG and WPR to obtain white balance.

7 RF.AGC Adjustment (Direct Number Button 4)

7-1 Receive 60dB RF signal. Connect digital voltmeter positive terminal to tuner AGC terminal and negative terminal to GND.

7-2 Press **CLOCK** , **PIC. MODE** , **SLEEP** buttons continuously to enter service mode. Press number button 4 and select RF AGC item by **P+** and **P-** to enter AGC adjustment.

7-3 Press **▲** and **▼** buttons to obtain 2.8V on the digital voltage meter or until there is no noise on screen.

7-4 Press **RECALL** button to exit service mode.

SERVICE ADJUSTMENTS

Service items

This table shows information about the service items that are available.

1. Press **CLOCK** , **PIC. MODE** , **SLEEP** buttons continuously on the remote control to enter service mode.
2. Press the number buttons on the remote control specified in the table to access directly into the respective items when in service mode.
3. Select the item using the **P+** and **P-** buttons and adjust using the **+** and **-** buttons.
4. Press **RECALL** button to exit service mode.

Item	Display string	Range (Index value)		Default value
Service information	SW10	Software Version (V1.1)		Fixed, not changeable
Number button "8"				
Init TV receiver	INIT	Active	1	0
		Inactive	0	
Number button "0"				
VSD	VG2	Active	1	0
		Inactive	0	
Number button "1"				
Horizontal parallelogram 50Hz	5PAR	0-63		31
Horizontal bow 50Hz	5BOW	0-63		31
Horizontal shift 50Hz	5HSH	0-63		47
EW width 50Hz	5EWW	0-63		33
EW parabola/width 50Hz	5EWP	0-63		31
EW upper corner parabola 50Hz	5UCR	0-63		31
EW lower corner parabola 50Hz	5LCR	0-63		31
EW trapezium 50Hz	5EWT	0-63		31
Horizontal parallelogram 60Hz	6PAR	0-63		31
Horizontal bow 60Hz	6BOW	0-63		31
Horizontal shift 60Hz	6HSH	0-63		31
EW width 60Hz	6EWW	0-63		31
EW parabola/width 60Hz	6EWP	0-63		31
EW upper corner parabola 60Hz	6UCR	0-63		31
EW lower corner parabola 60Hz	6LCR	0-63		31
EW trapezium 60Hz	6EWT	0-63		31
Number button "2"				
Vertical slope 50Hz	5VSL	0-63		26
Vertical amplitude 50Hz	5VAM	0-63		41
S-correction 50Hz	5SCL	0-63		31
Vertical shift 50Hz	5VSH	0-63		27
OSD vertical position offset 50Hz	5VOF	0-63		38
Horizontal shift 50Hz on RGB mode	5RGH	0-63		38
Vertical slope 60Hz	6VSL	0-63		29
Vertical amplitude 60Hz	6VAM	0-63		42
S-correction 60Hz	6SCL	0-63		31
Vertical shift 60Hz	6VSH	0-63		27
OSD vertical position offset 60Hz	6VOF	0-63		31

SERVICE ADJUSTMENTS

Item	Display string	Range (Index value)		Default value
Horizontal shift 60Hz on RGB mode	6RGH	0-63		38
OSD horizontal position offset	HOF	0-63		40
Vertical zoom	VX	0-63		19
Number button "3"				
Black level off-set R	RED	0-63		32
Black level off-set G	GRN	0-63		32
White point R (<i>Direct Key "Red"</i>)	WPR	0-63		31
White point G (<i>Direct Key "Green"</i>)	WPG	0-63		31
White point B (<i>Direct Key "Blue"</i>)	WPB	0-63		36
Luminance delay time PAL	YDFP	0-15		7
Luminance delay time NTSC	YDFN	0-15		7
Luminance delay time SECAM	YDFS	0-15		7
Luminance delay time AV	YDAV	0-15		7
Teletext brightness	TTBR	0-15		0
Mute delay	MUTD	0-20		13
Nicam/A2 mute delay	MDEL	0-127		60
Nicam frequency adjust	INIC	0-31		16
Filter bandwidth	FILT	0-3		2
Number button "4"				
AGC take-over	AGC	0-63		27
UOC Volume	VOL	0-63		0
Gain control for TDA9874	9874	0-30		16
SUB HUE control	SHUE	0-63		21
Gain control for TDA9859	9859	0-100		45
IF frequency	IFFS	38.9MHz	2	2
		38.0MHz	3	
Cathode drive level	HDOL	0-15		5
TUNR choose	TUNR	0-63		25
TELETEXT brightness control	TBRI	0-4		2
IF AGC speed	SPD	0.7X	0	1
		Normal	1	
		3X	2	
		6X	3	
VG2 Brightness	VG2B	0-63		31
Max Bass	MBAS	0-19		19
Max Bass when Trubass is ON	MTBA	0-19		19
Max treble	MTRE	0-12		8
Number button "6"				
Contrast -Min pre-set	CONO	0-100		6
Brightness -Min pre-set	BRIO	0-100		3
Colour-Min pre-set	COLO	0-100		0
Sharpness -Min pre-set	SHPO	0-100		0
Contrast -Middle pre-set	CO50	0-100		48
Brightness- Middle pre-set	BR50	0-100		42
Colour- Middle pre-set	CL50	0-100		42
Sharpness - Middle pre-set	SH50	0-100		40
RDB blanking time	RGBL	0-25		8

SERVICE ADJUSTMENTS

Item	Display string	Range (Index value)		Default value
Contrast -Rich pre-set	CONF	0-100		63
Brightness - Rich pre-set	BRIF	0-100		63
Colour -Rich pre-set	COLF	0-100		63
Sharpness - Rich pre-set	SHPF	0-100		63
Number button " 7 "				
LOW AC Voltage Protector Setting	VLOW	0-255		208
HIGH AC Voltage Protector Setting	VHIGH	0-255		5
Screen saver / Logo Left position	XMIN	0-255		38
Screen saver Right position	XMAX	0-255		186
Screen saver Top position	YMIN	0-63		46
Screen saver Bottom position	YMAX	0-63		61
Teletext Horizontal position	TXMI	0-255		40
Teletext Vertical position 50Hz	5TYM	0-63		38
Teletext Vertical position 60Hz	6TYM	0-63		38
Number button " 5 "				
NVM option 1	OP1	0	1	127
VG2 Alignment mode	Bit 0	AVG	VSD	1
YUV or Yprpb	Bit 1	YUV	Yprpb	1
XX	Bit 2	Off	On	1
XX	Bit 3	Off	On	1
AV2	Bit 4	Off	On	1
SVHS	Bit 5	Off	On	0
XX	Bit 6	Off	On	1
XX	Bit 7	Off	On	0
NVM option 2	OP2	0	1	62
AVL	Bit 0	Off	On	0
Auto sound in autosearch mode	Bit 1	Off	On	1
Pan Europe Teletext set	Bit 2	Off	On	0
Cyrillic Teletext set	Bit 3	Off	On	0
Farsi Teletext set	Bit 4	Off	On	0
Arabic Teletext set	Bit 5	Off	On	0
Sync On Y (YUV/Yprpb mode)	Bit 6	Off	On	Not in N2 "0"
Slicing lever	Bit 7	depend on noise	Fixed	0
NVM option 3	OP3	0	1	63
English Menu	Bit 0	Off	On	1
Farsi Menu	Bit 1	Off	On	1
Arabic Menu	Bit 2	Off	On	1
Turkish Menu	Bit 3	Off	On	1
France Menu	Bit 4	Off	On	1
Germany Menu	Bit 5	Off	On	1
Italy Menu	Bit 6	Off	On	0
Russia Menu	Bit 7	Off	On	0
NVM option 4	OP4	0	1	90
Narrow-band sound PLL window	Bit 0	Small	Large	0
Power mode	Bit 1	Standby	Last Memory	1
Geometry control	Bit 2	Off	On	0
Logo	Bit 3	Off	On	1
EHT tracking mode	Bit 4	Vertical	Vert. & EW	1
Search tuning mode sensitivity	Bit 5	Normal	Reduced	0
Menu half-tone	Bit 6	Off	On	1
Zoom function	Bit 7	Off	On	0

SERVICE ADJUSTMENTS

Item	Display string	Range (Index value)		Default value
Zoom function	Bit 7	Off	On	0
NVM option 5	OP5	0	1	207
Sound system DK	Bit 0	Off	On	1
Sound system BG	Bit 1	Off	On	1
Sound system I	Bit 2	Off	On	1
XX	Bit 3	Off	On	1
Reserve	Bit 4	X	X	0
Reserve	Bit 5	X	X	0
Switch-off in vertical overscan	Bit 6	Undefined	Vert. overscan	1
Power on to AV (Last status)	Bit 7	Off	On	1
NVM option 6	OP6	0	1	218
"No signal" OSD when no signal	Bit 0	Off	On	0
Blue screen or black screen	Bit 1	Black	Blue	1
16:9 mode	Bit 2	Off	On	0
Child lock (Lock local key)	Bit 3	Off	On	1
Top & bottom bar on Menu	Bit 4	Off	On	1
Mid line bar on Menu	Bit 5	Off	On	0
Set "POC" bit when no signal	Bit 6	Off	On	1
Game	Bit 7	Off	On	1
NVM option 7	OP7	0	1	65
AV1	Bit 0	Off	On	1
Selection QSS or AM out	Bit 1	QSS	AM	0
TV and monitor out select	Bit 2	Monitor	TV	0
LISTEN PRESET	Bit 3	Disable	Enable	0
Power on always	Bit 4	See OP4 bit 1	Direct On	0
Noise Reduce Off	Bit 5	See Table 1		0
Noise Reduce On	Bit 6			1
NTSC-M Control switch	Bit 7	1(FM)	0(QSS)	0
		ON	OFF	
Trubass control	BASS	1	0	0
Comb-filter Control	COMB	1	0	0
NICAM control	NICA	1	0	0
YUV Control	YUV	1	0	0
RGB control	RGB	1	0	0
NTSC-M Control	M	1	0	1
Direct Key "CLOCK"				Logo text "HITACHI"
Logo edit (7 chars. & 2 lines)	Logo Text	English letter & number etc.		Logo edit (7 chars. & 2 lines)

SERVICE ADJUSTMENTS

Table 1: AV CFG

Mode	Function select
0	TV→AV
1	TV→AV1→AV2
2	TV→AV1→AV2→S-VIDEO
3	TV→AV1→AV2→S-VIDEO→YUV
4	TV→AV1→AV2→YUV
5	TV→AV→S-VIDEO
6	TV→AV→S-VIDEO→YUV
7	TV→AV→YUV
8	TV-EURO
9	TV-AV-EURO

Table 2: SHIPMENT

Mode	Function select
CHANNEL	1
VOLUME	0
PICTURE	STANDARD
SOUND	MUSIC
HUE	0
BALANCE	0
COLOUR SYS.	AUTO
SOUND SYS.	See MENU1 SIFPFER
LANGUAGE	ENGLISH
BACKGROUND	ON
CHILD LOCK	OFF
BLACK STRETCH	ON
SURROUND	OFF

PURITY AND CONVERGENCE ADJUSTMENT

COLOUR PURITY ADJUSTMENT

1. Before colour purity adjustment, warm up the TV set for at least 15 minutes and fully degauss it.
2. Receive pure white signal in AV mode and press **[PIC.MODE]** button to set picture in DYNAMIC mode.
3. Loosen the clamp screw of the deflection yoke and pull the deflection yoke towards the purity magnet.
4. Adjust purity magnet to make the green area at the centre of the CRT screen.
5. Slowly push the deflection yoke toward the front of CRT and set it where a uniform green field is obtained. Tighten the clamp screw of the deflection yoke.

CONVERGENCE ADJUSTMENT

1. Receive a dotted pattern. Press **[PIC.MODE]** button to set picture in DYNAMIC mode.
2. Loosen the convergence magnet clamber and align red with blue dots at the centre of the screen by rotating (RB) static convergence magnets.
3. Align Red/Blue with green dots at the centre of the screen by rotating (RB-G) static convergence magnet.
4. Remove the DY wedges and slightly tilt the deflection yoke horizontally and vertically to obtain the best convergence result.

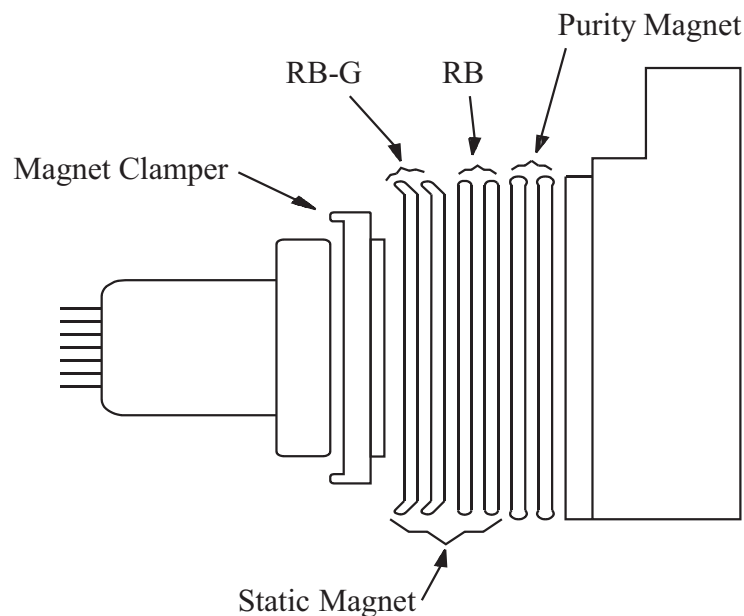

OPERATION INSTRUCTIONS

SETUP

Insert the Batteries

- 1** Remove the battery cover by pressing and sliding it down.
- 2** Insert the two 1.5V (AAA size) batteries making sure the polarity (+ or -) of the batteries matches the polarity marks inside the unit.
- 3** Replace the battery cover by sliding it in until you hear a click sound.

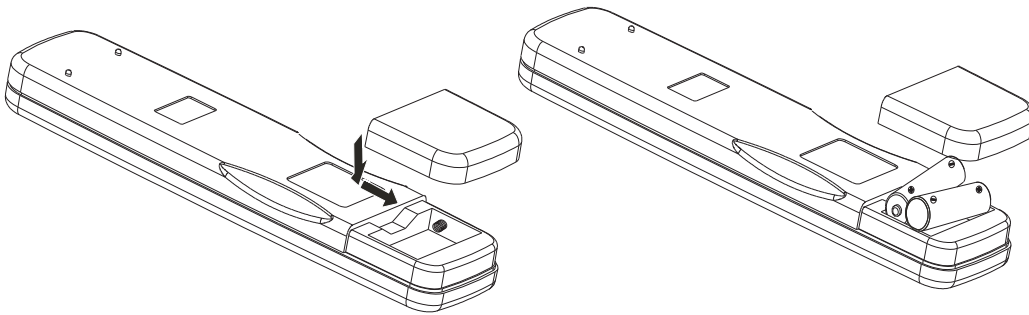

Precautions when using batteries

- Do not use old and new batteries together.
- Do not use different types of batteries (for example, Manganese and Alkaline batteries) together.
- Note that there are chargeable and non-chargeable batteries. Do not attempt to charge non-chargeable batteries.
- Remove the batteries from the remote control unit if the unit is not used for a long period of time.

Precautions when using the remote control unit

- Do not drop the remote control unit.
- Do not subject the remote control unit to physical shocks.
- Keep the remote control unit dry. Wetting it may cause the unit to malfunction.
- Replace the batteries with new ones when operation of the unit deteriorates.

CONTROL LOCATION

FUNCTIONAL PARTS

Front View of TV

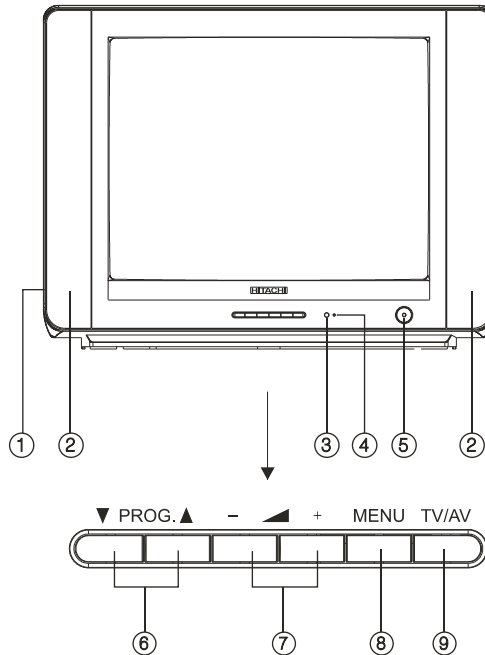

- ① Side Panel
- ② Speakers
- ③ Remote Sensor
- ④ Power Indicator
- ⑤ Power Switch
- ⑥ Program Up / Down Button
- ⑦ Volume Up / Down Button
- ⑧ Menu Button
- ⑨ TV/AV Button



To turn the TV power ON

Press the power switch on the TV to switch on the TV.
When the TV is ON, the power indicator lights up in green.

Standby Mode

At standby mode, the power indicator lights up in red.
You can switch on the TV or switch it to standby mode using the  button on the remote control unit. The picture usually takes a few seconds to appear.
You can also press any number (0-9),  or  buttons to switch it on from standby mode.

To turn the TV power OFF

Press the power switch on the TV to switch off the TV.
When the TV is off, the power indicator will not light up.

NOTE

- If the TV does not receive any signal for 5 minutes, it will enter standby mode.
 - If you are not going to use this TV for a long time, switch it off using the power switch and disconnect the power plug from the wall outlet.
 - Please note that the remote control unit can switch the TV to ON or to STANDBY mode only when the main power is ON.
-

INPUT AND OUTPUT TERMINALS

Rear View of TV

- ① AV OUT Terminals
- ② AV IN 1 Terminals
- ③ YCbCr In Terminals (YUV)
- ④ S-Video In Terminal
- ⑤ AC Power Cord
- ⑥ Antenna Input Socket (75 Ohm)

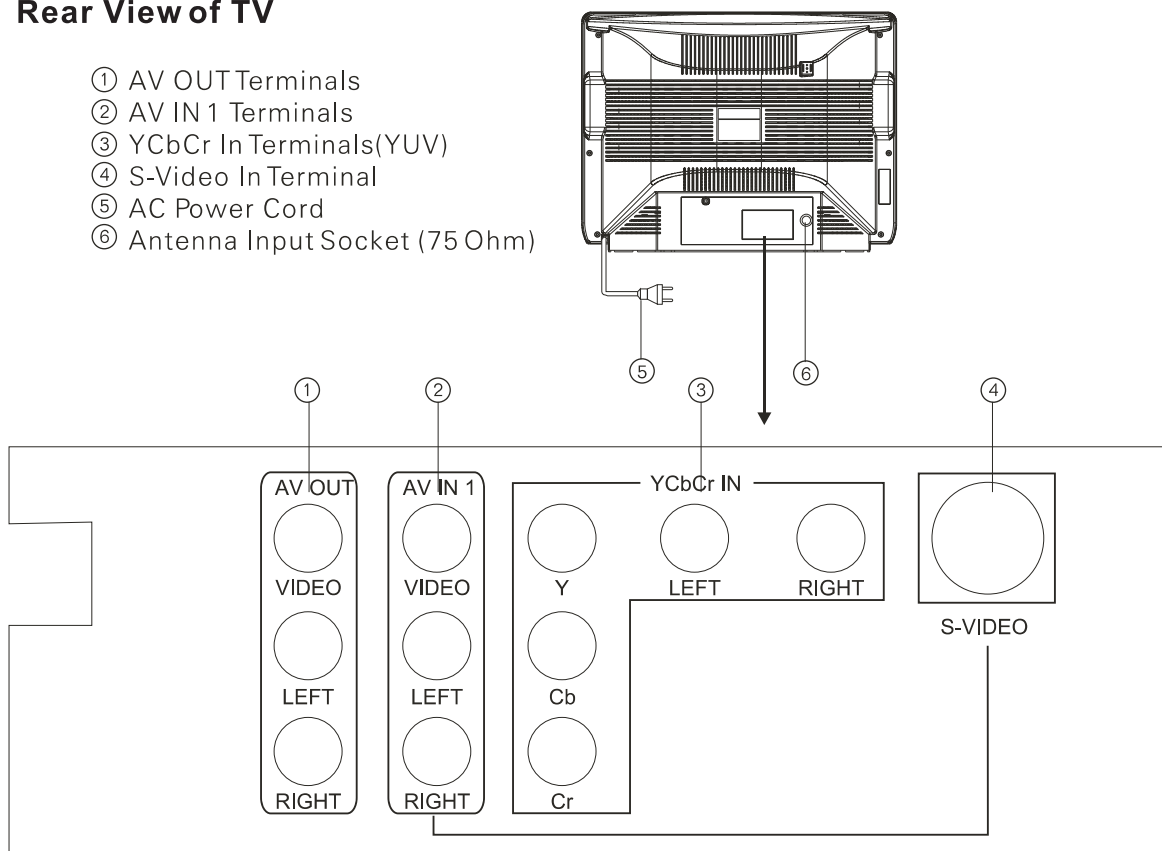

Side Panel of TV

- ① AV IN 2 Terminals
- ② Headphone Jack

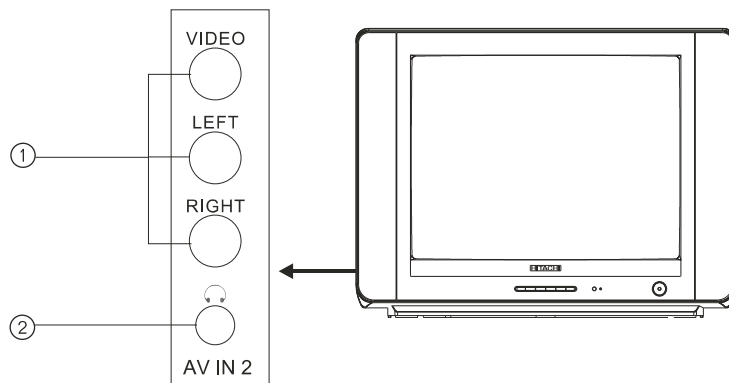

NOTE

- For Australia only - Install an external aerial conforming to AS 1417.1 for safety purpose.
- S.VIDEO and AV IN 1 (VIDEO) inputs cannot be used at the same time.

Precautions when connecting to other equipment

- When using external equipment with this TV, please read the instruction manual of the external equipment.
- Switch off all power supplies to the equipment and TV before connection.
- Always ensure that the input and output terminals are correctly connected.

REMOTE CONTROLLER FUNCTIONS

Remote Control Unit

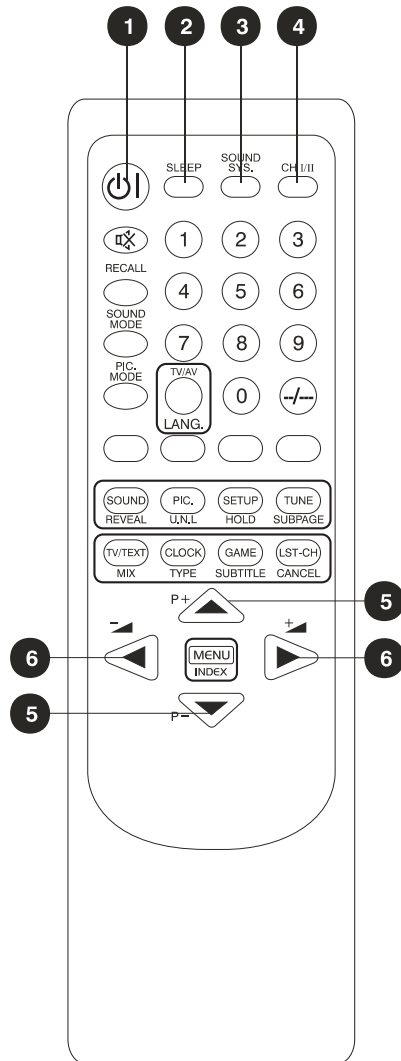

- 1 POWER ON / STANDBY button**
 Press this button to switch on the TV when at standby mode or vice versa.
 Press any number 0-9, **P+** or **P-** buttons will also switch on the TV from standby mode.
 - 2 SLEEP button**
 Press this button to set the sleep timer. When the preset length of time has passed, the TV set enters standby mode.
 - 3 SOUND SYSTEM button**
 Press this button to select the correct sound system.
 - 4 STEREO/BILINGUAL SOUND button*¹**
 When stereo program is received, press this button to select STEREO or MONO. In AV mode, press this button or select STEREO, CH-L or CH-R.
 When bilingual program is received, press this button to select DUAL-1, DUAL-2 or MONO.
 The screen will display NICAM or A2 when such broadcast is received.
- | Mode | Description |
|--------|------------------------------------|
| STEREO | Stereo mode |
| MONO | Mono mode |
| DUAL-1 | Multi-sound channel for language 1 |
| DUAL-2 | Multi-sound channel for language 2 |
| CH-L | Left sound track |
| CH-R | Right sound track |
- 5 CHANNEL UP **P+** / DOWN **P-** buttons*²**
 Press these buttons to select channels in ascending or descending order.
 - 6 VOLUME UP **+** / DOWN **-** buttons**
 Press these buttons to adjust the volume level up or down.

REMOTE CONTROLLER FUNCTIONS

Remote Control Unit

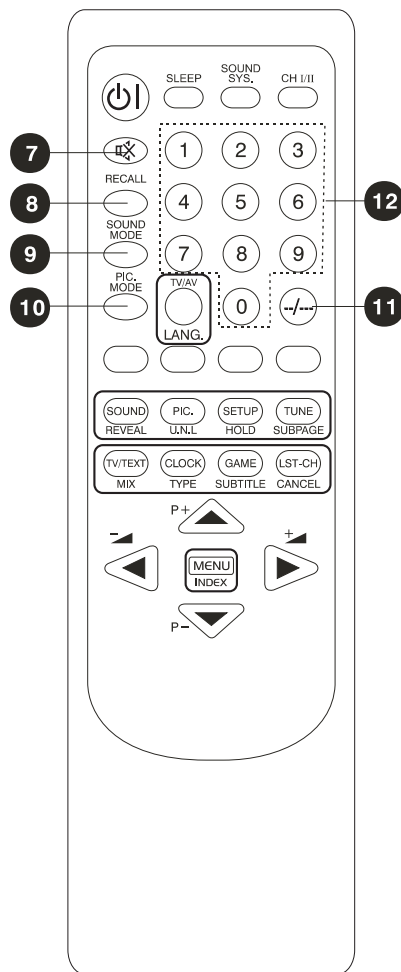

7 MUTE button

Press once to mute the sound. Press again to restore the sound volume.

8 RECALL button

Press this button to display the settings on the screen. (e.g. Channel number, system)

9 SOUND MODE button

Press this button to select the desired sound mode.

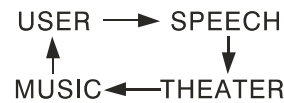

Sound Mode	Description
USER	User preset sound mode
SPEECH	Low treble and low bass level
THEATER	High treble and high bass level
MUSIC	Middle treble and middle bass level

10 PICTURE MODE button

Press this button to select the desired picture mode.

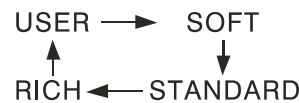

Picture Mode	Description
USER	User preset picture mode
SOFT	Low contrast and low brightness level
STANDARD	Middle contrast and middle brightness level
RICH	High contrast and high brightness level

11 DIGIT button

This TV allows you to select channels from 0 to 199.

Press this button to select one-digit, two-digit or three-digit channels input options. To select a one-digit channel (e.g. Channel 8), press this button to change channel selection to "-" on screen display and press the "8" button only.

To select a two-digit channel (e.g. Channel 28), press this button to change channel selection to "--" on screen display and press "2" and "8" buttons.

To select a three-digit channel (e.g. Channel 128), press this button to change channel selection to "1--" on screen display and press "2" and "8" buttons.

12 CHANNEL SELECTION buttons

Press the number buttons to select a channel.

REMOTE CONTROLLER FUNCTIONS

Remote Control Unit

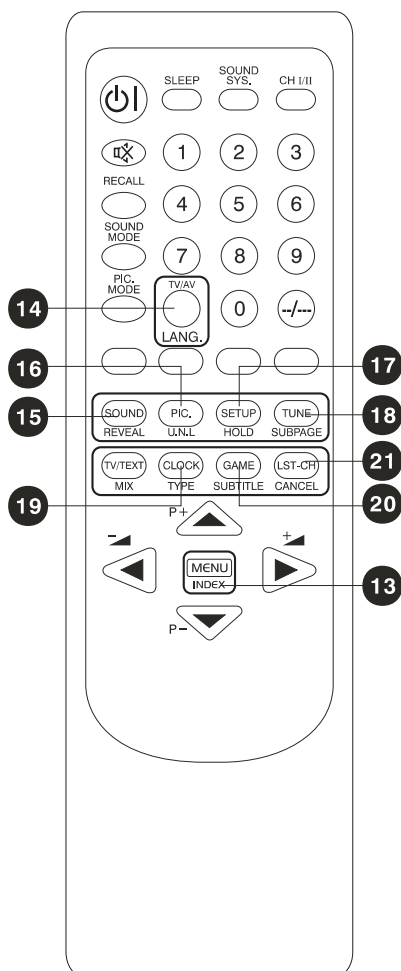

13 MENU button*²

Press this button to enter the menu screens for various optional adjustable settings.

14 TV/AV button*²

Press this button to switch between TV broadcasts and AV input programs.

TV → AV1 → AV2
 ↑ ↓
 YCbCr ← S-Video

15 SOUND MENU button*²

Press this button to enter into the [SOUND] menu directly.

16 PICTURE MENU button*²

Press this button to enter into the [PICTURE] menu directly.

17 SETUP MENU button*²

Press this button to enter into the [SETUP] menu directly.

18 TUNE MENU button*²

Press this button to enter into the [TUNE] menu directly.

19 CLOCK button*²

Press this button to display the preset clock time.

20 GAME button*²

Press this button to enter the game provided with this TV. Press this button again or [RECALL] button to exit.

Buttons	Actions In Game
[P-]	To speed up
[P+]	To transform
[←]	To shift left
[→]	To shift right
[MENU]	To pause the game

21 LAST CHANNEL button*²

Press this button to return to previously viewed channel.

NOTE

*¹ Only applicable to models with NICAM and Sound Multiplex function only.

*² See "Teletext Operations" section for details of these buttons functions in Teletext mode. Only applicable to models with Teletext function only.

REMOTE CONTROLLER FUNCTIONS

TELETEXT OPERATIONS

For models with Teletext function only.

This page shows the function of the buttons on the remote control unit when in Teletext mode

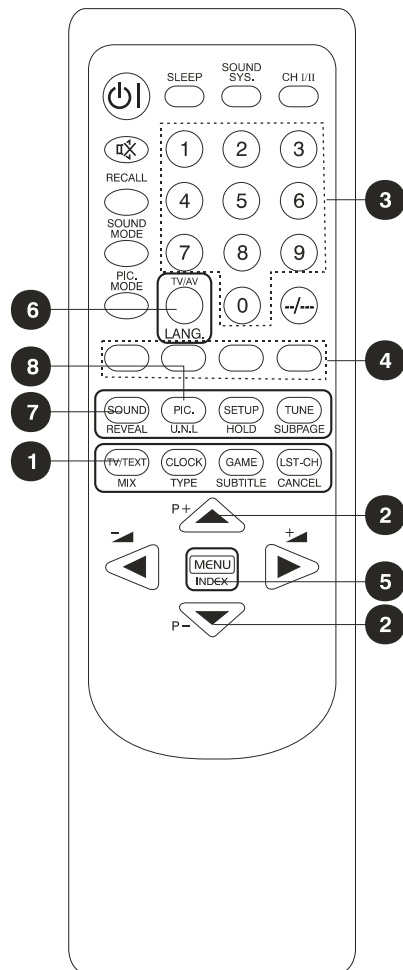

1 TV/TEXT button

Press this button to enter Teletext mode.
Press this button the second time to superimpose the teletext page over the TV programme.
Press this button again to exit.

2 TELETEXT PAGE UP [P+] / DOWN [P-] buttons

Press these buttons to increase or decrease the Teletext page number.

3 PAGE NUMBER SELECTION buttons

Press the number buttons to select a Teletext page number.

4 COLOUR buttons

Press these buttons to access directly to the corresponding pages displayed at the lower part of the Teletext screen.

5 INDEX button

Press this button to go to the index page.

6 LANGUAGE button

Press this button to select the Teletext language (if applicable e.g. English or Russian).

7 REVEAL button

Press this button to reveal the hidden information for some Teletext pages (e.g. answers to puzzles or riddles). Press again to hide the information.

8 U.N.L button

Press this button to change the Teletext screen display mode through the following:

- Upper half screen enlarged
- Lower half screen enlarged
- Normal screen state

REMOTE CONTROLLER FUNCTIONS

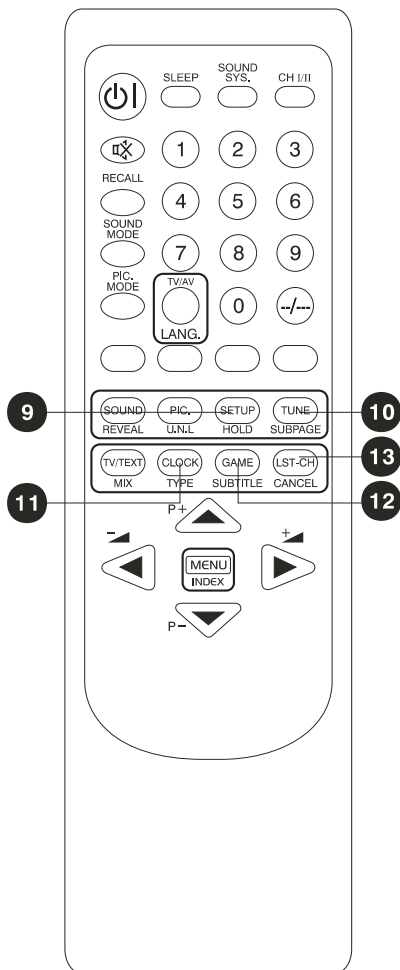

- 9 HOLD** button
Press this button to hold the Teletext page on display to prevent the page from changing. Press again to release the hold state.
- 10 SUB PAGE** button
Some Teletext pages may contain several sub-pages which are automatically paged in a certain cycle by the TV station. Press this button once, "0001" will be displayed on screen. Enter number buttons (0-9) to look for other sub-pages if available. If there is no sub-pages, "****" will be displayed. Press this button again to cancel.
- 11 TYPE** button
Press this button to switch the Teletext type such as west/east type directly if applicable.
- 12 SUB TITLE** button
Some TV channels transmit program with optional sub-titles. Press this button to view sub-titles if applicable.
- 13 CANCEL** button
Press this button to return to the TV mode temporarily while searching for a required text page. When the required text page has been received, the page number will be displayed at the top left of the screen. Press this button again to display the teletext screen.

MENU SCREENS

This TV allows you to adjust the settings from the menu screens.

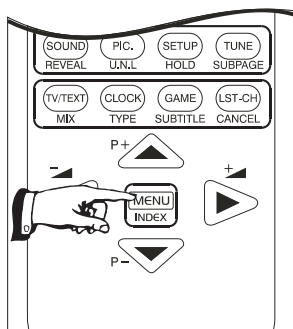

Press the **[MENU]** button to enter the menu screens for the following settings.

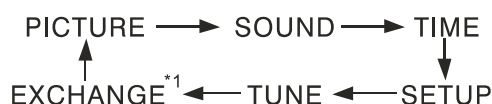

[PICTURE] menu

PICTURE	
BRIGHTNESS	25
CONTRAST	25
COLOUR	25
SHARPNESS	25
HUE	0
BLACK STRETCH	OFF

This menu allows you to adjust the picture settings according to your preference.

- 1 Press the **[MENU]** button or press the **[PIC.]** button directly.
- 2 Select the desired item using the **[P+]** and **[P-]** buttons.
- 3 Use the **[▲]** and **[▼]** buttons to adjust the settings.
- 4 Press the **[MENU]** button repeatedly or press the **[PIC.]** button to exit the menu screen.

Selected Items	Functions
BRIGHTNESS	Adjust brightness level
CONTRAST	Adjust contrast level
COLOUR	Adjust colour intensity
SHARPNESS	Adjust sharpness level
HUE ^{*2}	Adjust the hue towards red(+) or green(-) picture tones
BLACK STRETCH	Select ON to extend the black levels to enhance contrast

NOTE

*1 [EXCHANGE] menu will not be available in AV mode.

*2 HUE can only be selected and adjusted when receiving NTSC broadcasts.

ON SCREEN DISPLAYS

[SOUND] menu

SOUND	
VOLUME	6
BASS	25
TREBLE	25
BALANCE	0
SURROUND	ON

This menu allows you to adjust the sound settings according to your preference.

- 1 Press the **[MENU]** button repeatedly or press the **[SOUND]** button directly.
- 2 Select the desired item using the **[P+]** and **[P-]** buttons.
- 3 Use the **[+]** and **[-]** buttons to adjust the settings.
- 4 Press the **[MENU]** button repeatedly or press the **[SOUND]** button to exit the menu screen.

Selected Items	Functions
VOLUME	Adjust volume level
BASS	Adjust bass level
TREBLE	Adjust treble level
BALANCE	Adjust speaker sound towards left(-) or right (+) speaker
SURROUND	Select ON to enjoy surround sound effect

[TIME] menu*1

TIME	
CLOCK	--
ON TIME	--
ON PROG	1
OFF TIME	--
SLEEP TIMER	20
REMIND TIME	--
REMIND PROG	1

This menu allows you to set the various timer functions.

- 1 Press the **[MENU]** button repeatedly.
- 2 Select the desired item (e.g. Hour, minute, channel number) using the **[P+]** and **[P-]** buttons.
- 3 Use the **[+]** and **[-]** buttons to adjust the settings.
- 4 Press the **[MENU]** button repeatedly to exit the menu screen.

Selected Items	Functions
CLOCK	Set the current clock time
ON TIME	Set the clock time to switch on TV
ON PROG	Set the channel number for ON TIME activation
OFF TIME	Set the clock time to switch off TV
SLEEP TIMER	Set the length of time to switch off TV
REMIND TIME	Set the clock time to change to REMIND PROG channel
REMIND PROG	Set the channel number for REMIND TIME activation

NOTE

*1 All the timer functions will only be effective if the power of the TV set is switched off using the remote control unit. If the power is switched off by the power button on the TV set or a power failure occurs, the timer will be reset.

ON SCREEN DISPLAYS

[SETUP] menu

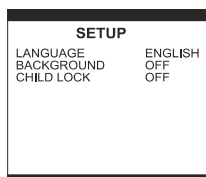

This menu allows you to adjust the various setup functions.

- 1 Press the **[MENU]** button repeatedly or press the **[SETUP]** button directly.
- 2 Select the desired item using the **[P+]** and **[P-]** buttons.
- 3 Use the **[+]** and **[-]** buttons to adjust the settings.
- 4 Press the **[MENU]** button repeatedly or press the **[SETUP]** button to exit the menu screen.

Selected Items	Functions
LANGUAGE	Select the on-screen display language
BACKGROUND	Select ON to change screen to blue at no signal condition
CHILD LOCK ^{*1}	Select ON to disable access to TV via buttons on TV

[TUNE] menu^{*2}

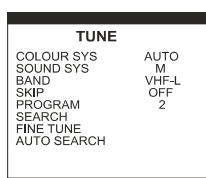

This menu allows you to set a channel to a desired TV station.

- 1 Press the **[MENU]** button repeatedly or press the **[TUNE]** button directly.
- 2 Select the desired item using the **[P+]** and **[P-]** buttons.
- 3 Use the **[+]** and **[-]** buttons to adjust/activate the functions.
- 4 Press the **[MENU]** button repeatedly or press the **[TUNE]** button to exit the menu screen.

Selected Items	Functions
COLOUR SYS ^{*3}	Select the appropriate colour system
SOUND SYS	Select the appropriate sound system (i.e. I, M, DK or BG)
BAND	Select band system for tuning (i.e. VHF-L, VHF-H or UHF)
SKIP ^{*4}	Select ON to skip the channel in PROGRAM
PROGRAM	Set the channel number by number buttons or [...] button
SEARCH	Activate to manually search for desired broadcast stations
FINE TUNE ^{*5}	Fine tune the unsatisfactory signal reception
AUTO SEARCH	Activate to auto search & preset receivable broadcast stations

NOTE

- *1 If CHILD LOCK is set to ON, you can access the TV by remote control unit only. You may keep the remote control unit out of reach to prevent children from any unauthorized access to the TV.
- *2 In AV mode, only COLOUR SYS will be displayed in [TUNE] menu.
- *3 If COLOUR SYS is set to AUTO, the colour system will be detected and selected automatically. If the signal reception is poor, an incorrect colour system may be detected and selected. You can rectify this problem by setting the colour system (PAL, NTSC, NTSC4.43 or SECAM) manually.
- *4 When SKIP is set to ON, the channel number will be changed from green to white.
- *5 When using FINE TUNE to adjust the signal reception, the channel number will be changed from green to yellow; if SKIP is set to ON at the same time, the channel number will be changed from yellow to grey.

ON SCREEN DISPLAYS

[EXCHANGE] menu*1

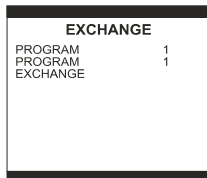

This menu allows you to arrange channel numbers by exchanging between 2 preset channel numbers.

- 1 Press the **[MENU]** button repeatedly.
- 2 Select the first PROGRAM item using the **[P+]** and **[P-]** buttons. Use the **[+]** and **[-]** buttons to select the channel number you want to exchange from.
- 3 Select the second PROGRAM item using the **[P+]** and **[P-]** buttons. Use the **[+]** and **[-]** buttons to select the channel number you want to exchange to.
- 4 Select EXCHANGE and press the **[+]** or **[-]** buttons to activate the exchange command.
- 5 Press the **[MENU]** button to exit the menu screen.

NOTE

*1 [EXCHANGE] menu is not available in AV mode.

MECHANICAL ASSEMBLY

REAR COVER REMOVAL

1. Remove screws from the rear cover as shown in Figure 1.
2. Remove the rear cover.

CHASSIS REMOVAL

1. Remove the rear cover (refer to REAR COVER REMOVAL instructions).
2. Discharge the picture tube anode (2nd anode lead) to the dag coating (picture tube grounding lead).
3. Disconnect the degaussing coil (KE), picture tube socket, deflection yoke connector (KDY), speaker connectors (KL and KR) and 2nd anode lead.
4. Remove chassis completely by sliding it out.

PICTURE TUBE REMOVAL

1. Remove the chassis (refer to CHASSIS REMOVAL instructions).
2. Place the front frame face down on a soft surface.
3. Remove the screws on each corner of the picture tube and GENTLY lift the picture tube out of the front frame.
4. Install a replacement picture tube & properly install the degaussing coil and picture tube grounding lead on the picture tube as shown in Figure 2.

CAUTION

- Discharge the picture tube to the coating before handling the tube.
- Do not adjust the deflection yoke or magnet assembly on the picture tube.
- Care must be taken to keep these assemblies intact, unless picture tube is to be replaced.

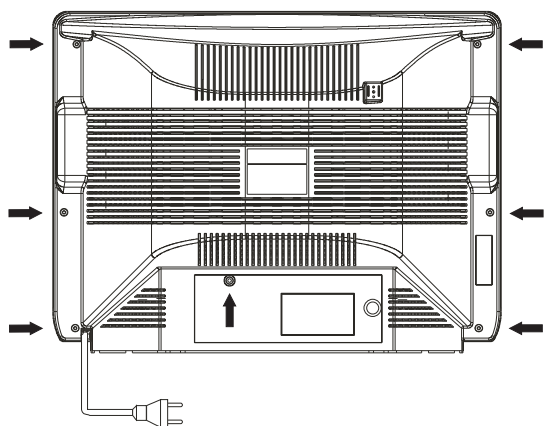

Figure 1

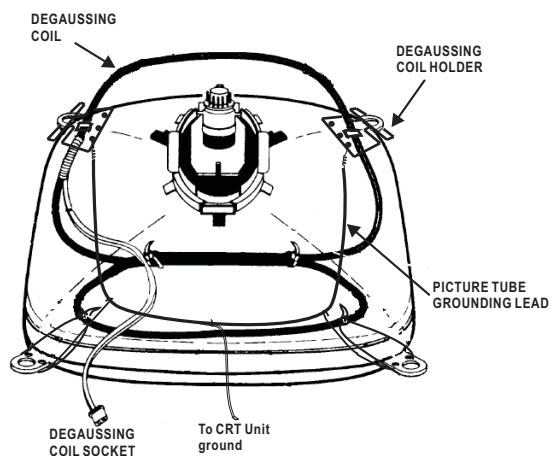















Figure 2

REPLACEMENT PARTS LIST

The following service parts list are available for purchase. Serviceman may quote the components shown in this page for servicing purposes.

PRODUCT SAFETY NOTE: Critical parts that have special safety characteristics are identified by a  in the replacement parts list or the schematic diagrams. Use of any substitute replacement part that does not have the same safety characteristics as the recommended replacement part in the parts list might create shock, fire and/or other hazards. Please do not degrade the safety of this TV through improper servicing.

SYMBOL No.	PART No.	DESCRIPTIONS
A301	YZ5200389W1600	FS Tuner
 C455	YZ4300ET822C00	Metallized Poly Film 0.0082uF 2KV +/- 5%
 C455A	YZ4300ET102C00	Metallized Poly Film 0.001uF 2KV +/- 5%
 C601	YZ4300FW224D00	AC Cap. 0.22uF AC250V-500V +/- 10%
 C602	YZ4300FW224D00	AC Cap. 0.22uF AC250V-500V +/- 10%
 C607	YZ4300BL227E00	Electrolytic Cap. 220uF 400V +/- 20%
 C629	YZ4304SX222E00	Ceramic Cap. 0.0022uF AC250V-400V +/- 20%
 F601	YZ600135000100	Fuse T3.15A 250V
 H601	YZ5926A2830001	AC Power Cord (CEE Plug for 081, 433, 192 etc...)
 H601	YZ5926A2830002	AC Power Cord (BS Plug for Code 051, 201, 191 only)
 H601	YZ5926A2830602	AC Power Cord (Australia Plug for Code 751 only)
 H602	YZ480008230002	21" TV Degaussing Coil L-2300mm
IC121	YZ4706D9859032	IC TDA9859 (HI-FI Audio Processor)
IC161	YZ4706D8944017	IC TDA8944J (Audio Amplifier)
IC181	YZ4707L7805003	IC L7805CV
IC401	YZ4707S9302007	IC STV9302A (V. Deflection w/flyback generator)
IC501	YZ4706D6107Q09	IC TDA6107Q (Video out Amplifier)
IC601	YZ4780K0765005	IC KA5Q0765RTH-YDTU (Power Switch)
 IC602	YZ4701T6210J04	IC TLP621 (Photo Transistor)
IC652	YZ4707L7808003	IC L7808CV SGS (Stabilizing)
IC653	YZ4707L7805003	IC L7805CV
IC701	YZ4706D9367064	IC TDA9367PS/N2 (with Text & Nicam - for C21-F880SNT)
IC701	YZ4706D9381064	IC TDA9381PS/N2 (w/o Text & Nicam - for C21-F880S)
IC702	YZ470024C08008	IC 8K-Bit IIC Bus Serial EEPROM
IC703	YZ4709KA33VT02	IC KA33V (VT)
IC861	YZ4706D9874044	IC TDA9874A (TV Sound Demodulator/Decoder)
 L601	YZ480006250000	Line Filter 25mH
 L602	YZ480006150500	Line Filter 15mH
Q450	YZ4600C24822T0	Transistor 2SC2482/3DG2482Y
Q451	YZ4600D2499000	Transistor 2SC2499/3DD2499
 R629	YZ4101HG8250T0	High-Volt Resistor 8.2M Ohm 1W +/- 5%
 SW601A	YZ550002021100	Main Power Switch KDC-A11
T450	YZ510604100000	Horizontal Drive Transformer for Low Voltage
 T451	YZ510105110104	21" Flyback Transformer
 T601	YZ511506400103	Switching Transformer
 TH601	YZ4135KZ090002	PTC Thermistor Resistor 9 Ohm
 XS501	YZ610006010829	CRT Socket
	YZ0806RC090003	Remote Control Handset

ELECTRICAL PARTS LIST

FOR REFERENCE ONLY

The components shown in page 39-54 serve as a reference. It is not meant for ordering of components for servicing purposes. Do not quote any components from these lists.

Circuit No	Part No	Description
013PAST001A0M		MAIN ASSEMBLY (AUTO INSERT)
R309	YZ4100AB1000T0	CARBON FILM RESISTOR 10 OHM 1/16-1/6W +/-5% (TAPE TYPE)
R801	YZ4100AB1000T0	CARBON FILM RESISTOR 10 OHM 1/16-1/6W +/-5% (TAPE TYPE)
R829	YZ4100AB1000T0	CARBON FILM RESISTOR 10 OHM 1/16-1/6W +/-5% (TAPE TYPE)
R861	YZ4100AB1000T0	CARBON FILM RESISTOR 10 OHM 1/16-1/6W +/-5% (TAPE TYPE)
R865	YZ4100AB1000T0	CARBON FILM RESISTOR 10 OHM 1/16-1/6W +/-5% (TAPE TYPE)
R866	YZ4100AB1000T0	CARBON FILM RESISTOR 10 OHM 1/16-1/6W +/-5% (TAPE TYPE)
R867	YZ4100AB1000T0	CARBON FILM RESISTOR 10 OHM 1/16-1/6W +/-5% (TAPE TYPE)
R868	YZ4100AB1000T0	CARBON FILM RESISTOR 10 OHM 1/16-1/6W +/-5% (TAPE TYPE)
R124	YZ4100AB1010T0	CARBON FILM RESISTOR 100 OHM 1/16-1/6W +/-5% (TAPE TYPE)
R125	YZ4100AB1010T0	CARBON FILM RESISTOR 100 OHM 1/16-1/6W +/-5% (TAPE TYPE)
R301	YZ4100AB1010T0	CARBON FILM RESISTOR 100 OHM 1/16-1/6W +/-5% (TAPE TYPE)
R302	YZ4100AB1010T0	CARBON FILM RESISTOR 100 OHM 1/16-1/6W +/-5% (TAPE TYPE)
R354	YZ4100AB1010T0	CARBON FILM RESISTOR 100 OHM 1/16-1/6W +/-5% (TAPE TYPE)
R365	YZ4100AB1010T0	CARBON FILM RESISTOR 100 OHM 1/16-1/6W +/-5% (TAPE TYPE)
R366	YZ4100AB1010T0	CARBON FILM RESISTOR 100 OHM 1/16-1/6W +/-5% (TAPE TYPE)
R381	YZ4100AB1010T0	CARBON FILM RESISTOR 100 OHM 1/16-1/6W +/-5% (TAPE TYPE)
R382	YZ4100AB1010T0	CARBON FILM RESISTOR 100 OHM 1/16-1/6W +/-5% (TAPE TYPE)
R383	YZ4100AB1010T0	CARBON FILM RESISTOR 100 OHM 1/16-1/6W +/-5% (TAPE TYPE)
R401	YZ4100AB1010T0	CARBON FILM RESISTOR 100 OHM 1/16-1/6W +/-5% (TAPE TYPE)
R402	YZ4100AB1010T0	CARBON FILM RESISTOR 100 OHM 1/16-1/6W +/-5% (TAPE TYPE)
R452	YZ4100AB1010T0	CARBON FILM RESISTOR 100 OHM 1/16-1/6W +/-5% (TAPE TYPE)
R723	YZ4100AB1010T0	CARBON FILM RESISTOR 100 OHM 1/16-1/6W +/-5% (TAPE TYPE)
R724	YZ4100AB1010T0	CARBON FILM RESISTOR 100 OHM 1/16-1/6W +/-5% (TAPE TYPE)
R725	YZ4100AB1010T0	CARBON FILM RESISTOR 100 OHM 1/16-1/6W +/-5% (TAPE TYPE)
R806	YZ4100AB1010T0	CARBON FILM RESISTOR 100 OHM 1/16-1/6W +/-5% (TAPE TYPE)
R841	YZ4100AB1010T0	CARBON FILM RESISTOR 100 OHM 1/16-1/6W +/-5% (TAPE TYPE)
R862	YZ4100AB1010T0	CARBON FILM RESISTOR 100 OHM 1/16-1/6W +/-5% (TAPE TYPE)
R863	YZ4100AB1010T0	CARBON FILM RESISTOR 100 OHM 1/16-1/6W +/-5% (TAPE TYPE)
L803	YZ4100AB1020T0	CARBON FILM RESISTOR 1K OHM 1/16-1/6W +/-5% (TAPE TYPE)
L804	YZ4100AB1020T0	CARBON FILM RESISTOR 1K OHM 1/16-1/6W +/-5% (TAPE TYPE)
L841	YZ4100AB1020T0	CARBON FILM RESISTOR 1K OHM 1/16-1/6W +/-5% (TAPE TYPE)
L842	YZ4100AB1020T0	CARBON FILM RESISTOR 1K OHM 1/16-1/6W +/-5% (TAPE TYPE)
R460	YZ4100AB1020T0	CARBON FILM RESISTOR 1K OHM 1/16-1/6W +/-5% (TAPE TYPE)
R464	YZ4100AB1020T0	CARBON FILM RESISTOR 1K OHM 1/16-1/6W +/-5% (TAPE TYPE)
R647	YZ4100AB1020T0	CARBON FILM RESISTOR 1K OHM 1/16-1/6W +/-5% (TAPE TYPE)
R827	YZ4100AB1020T0	CARBON FILM RESISTOR 1K OHM 1/16-1/6W +/-5% (TAPE TYPE)
R828	YZ4100AB1020T0	CARBON FILM RESISTOR 1K OHM 1/16-1/6W +/-5% (TAPE TYPE)
R842	YZ4100AB1020T0	CARBON FILM RESISTOR 1K OHM 1/16-1/6W +/-5% (TAPE TYPE)
R843	YZ4100AB1020T0	CARBON FILM RESISTOR 1K OHM 1/16-1/6W +/-5% (TAPE TYPE)
R847	YZ4100AB1020T0	CARBON FILM RESISTOR 1K OHM 1/16-1/6W +/-5% (TAPE TYPE)
R123	YZ4100AB1030T0	CARBON FILM RESISTOR 10K OHM 1/16-1/6W +/-5% (TAPE TYPE)
R126	YZ4100AB1030T0	CARBON FILM RESISTOR 10K OHM 1/16-1/6W +/-5% (TAPE TYPE)
R172	YZ4100AB1030T0	CARBON FILM RESISTOR 10K OHM 1/16-1/6W +/-5% (TAPE TYPE)
R173	YZ4100AB1030T0	CARBON FILM RESISTOR 10K OHM 1/16-1/6W +/-5% (TAPE TYPE)
R174	YZ4100AB1030T0	CARBON FILM RESISTOR 10K OHM 1/16-1/6W +/-5% (TAPE TYPE)
R176	YZ4100AB1030T0	CARBON FILM RESISTOR 10K OHM 1/16-1/6W +/-5% (TAPE TYPE)
R177	YZ4100AB1030T0	CARBON FILM RESISTOR 10K OHM 1/16-1/6W +/-5% (TAPE TYPE)

ELECTRICAL PARTS LIST

FOR REFERENCE ONLY

Circuit No	Part No	Description
R380	YZ4100AB1030T0	CARBON FILM RESISTOR 10K OHM 1/16-1/6W +/-5% (TAPE TYPE)
R645	YZ4100AB1030T0	CARBON FILM RESISTOR 10K OHM 1/16-1/6W +/-5% (TAPE TYPE)
R646	YZ4100AB1030T0	CARBON FILM RESISTOR 10K OHM 1/16-1/6W +/-5% (TAPE TYPE)
R648	YZ4100AB1030T0	CARBON FILM RESISTOR 10K OHM 1/16-1/6W +/-5% (TAPE TYPE)
R729	YZ4100AB1030T0	CARBON FILM RESISTOR 10K OHM 1/16-1/6W +/-5% (TAPE TYPE)
R812	YZ4100AB1030T0	CARBON FILM RESISTOR 10K OHM 1/16-1/6W +/-5% (TAPE TYPE)
R813	YZ4100AB1030T0	CARBON FILM RESISTOR 10K OHM 1/16-1/6W +/-5% (TAPE TYPE)
R833	YZ4100AB1030T0	CARBON FILM RESISTOR 10K OHM 1/16-1/6W +/-5% (TAPE TYPE)
R483	YZ4100AB1040T0	CARBON FILM RESISTOR 100K OHM 1/16-1/6W +/-5% (TAPE TYPE)
R154	YZ4100AB1520T0	CARBON FILM RESISTOR 1.5K OHM 1/16-1/6W +/-5% (TAPE TYPE)
R158	YZ4100AB1520T0	CARBON FILM RESISTOR 1.5K OHM 1/16-1/6W +/-5% (TAPE TYPE)
R303	YZ4100AB1520T0	CARBON FILM RESISTOR 1.5K OHM 1/16-1/6W +/-5% (TAPE TYPE)
R307	YZ4100AB1520T0	CARBON FILM RESISTOR 1.5K OHM 1/16-1/6W +/-5% (TAPE TYPE)
R403	YZ4100AB1520T0	CARBON FILM RESISTOR 1.5K OHM 1/16-1/6W +/-5% (TAPE TYPE)
R405	YZ4100AB1520T0	CARBON FILM RESISTOR 1.5K OHM 1/16-1/6W +/-5% (TAPE TYPE)
R649	YZ4100AB1520T0	CARBON FILM RESISTOR 1.5K OHM 1/16-1/6W +/-5% (TAPE TYPE)
R816	YZ4100AB1520T0	CARBON FILM RESISTOR 1.5K OHM 1/16-1/6W +/-5% (TAPE TYPE)
R817	YZ4100AB1520T0	CARBON FILM RESISTOR 1.5K OHM 1/16-1/6W +/-5% (TAPE TYPE)
R121	YZ4100AB1530T0	CARBON FILM RESISTOR 15K OHM 1/16-1/6W +/-5% (TAPE TYPE)
R128	YZ4100AB1530T0	CARBON FILM RESISTOR 15K OHM 1/16-1/6W +/-5% (TAPE TYPE)
R317	YZ4100AB1530T0	CARBON FILM RESISTOR 15K OHM 1/16-1/6W +/-5% (TAPE TYPE)
R331	YZ4100AB1530T0	CARBON FILM RESISTOR 15K OHM 1/16-1/6W +/-5% (TAPE TYPE)
R311	YZ4100AB1810T0	CARBON FILM RESISTOR 180 OHM 1/16-1/6W +/-5% (TAPE TYPE)
R353	YZ4100AB1810T0	CARBON FILM RESISTOR 180 OHM 1/16-1/6W +/-5% (TAPE TYPE)
R481	YZ4100AB1810T0	CARBON FILM RESISTOR 180 OHM 1/16-1/6W +/-5% (TAPE TYPE)
R710	YZ4100AB1810T0	CARBON FILM RESISTOR 180 OHM 1/16-1/6W +/-5% (TAPE TYPE)
R777	YZ4100AB1810T0	CARBON FILM RESISTOR 180 OHM 1/16-1/6W +/-5% (TAPE TYPE)
R844	YZ4100AB1810T0	CARBON FILM RESISTOR 180 OHM 1/16-1/6W +/-5% (TAPE TYPE)
R305	YZ4100AB2220T0	CARBON FILM RESISTOR 2.2K OHM 1/6W +/-5%(TAPE TYPE)
R312	YZ4100AB2220T0	CARBON FILM RESISTOR 2.2K OHM 1/6W +/-5%(TAPE TYPE)
R351	YZ4100AB2220T0	CARBON FILM RESISTOR 2.2K OHM 1/6W +/-5%(TAPE TYPE)
R451	YZ4100AB2220T0	CARBON FILM RESISTOR 2.2K OHM 1/6W +/-5%(TAPE TYPE)
R709	YZ4100AB1030T0	CARBON FILM RESISTOR 10K OHM 1/16-1/6W +/-5%(TAPE TYPE)
R614	YZ4100AB2420T0	CARBON FILM RESISTOR 2.4K OHM 1/16-1/6W +/-5% (TAPE TYPE)
R644	YZ4100AB2420T0	CARBON FILM RESISTOR 2.4K OHM 1/16-1/6W +/-5% (TAPE TYPE)
R318	YZ4100AB2730T0	CARBON FILM RESISTOR 27K OHM 1/16-1/6W +/-5% (TAPE TYPE)
R384	YZ4100AB2730T0	CARBON FILM RESISTOR 27K OHM 1/16-1/6W +/-5% (TAPE TYPE)
R484	YZ4100AB2730T0	CARBON FILM RESISTOR 27K OHM 1/16-1/6W +/-5% (TAPE TYPE)
R487	YZ4100AB2730T0	CARBON FILM RESISTOR 27K OHM 1/16-1/6W +/-5% (TAPE TYPE)
R775	YZ4100AB3010T0	CARBON FILM RESISTOR 300 OHM 1/16-1/6W +/-5% (TAPE TYPE)
R171	YZ4100AB3320T0	CARBON FILM RESISTOR 3.3K OHM 1/16-1/6W +/-5% (TAPE TYPE)
R175	YZ4100AB3320T0	CARBON FILM RESISTOR 3.3K OHM 1/16-1/6W +/-5% (TAPE TYPE)
R721	YZ4100AB3320T0	CARBON FILM RESISTOR 3.3K OHM 1/16-1/6W +/-5% (TAPE TYPE)
R722	YZ4100AB3320T0	CARBON FILM RESISTOR 3.3K OHM 1/16-1/6W +/-5% (TAPE TYPE)
R728	YZ4100AB3320T0	CARBON FILM RESISTOR 3.3K OHM 1/16-1/6W +/-5% (TAPE TYPE)
R735	YZ4100AB3320T0	CARBON FILM RESISTOR 3.3K OHM 1/16-1/6W +/-5% (TAPE TYPE)
R737	YZ4100AB3320T0	CARBON FILM RESISTOR 3.3K OHM 1/16-1/6W +/-5% (TAPE TYPE)
R741	YZ4100AB3320T0	CARBON FILM RESISTOR 3.3K OHM 1/16-1/6W +/-5% (TAPE TYPE)

ELECTRICAL PARTS LIST

FOR REFERENCE ONLY

Circuit No	Part No	Description
R742	YZ4100AB3320T0	CARBON FILM RESISTOR 3.3K OHM 1/16-1/6W+/-5% (TAPE TYPE)
R834	YZ4100AB3320T0	CARBON FILM RESISTOR 3.3K OHM 1/16-1/6W+/-5% (TAPE TYPE)
R845	YZ4100AB3320T0	CARBON FILM RESISTOR 3.3K OHM 1/16-1/6W+/-5% (TAPE TYPE)
R846	YZ4100AB3320T0	CARBON FILM RESISTOR 3.3K OHM 1/16-1/6W+/-5% (TAPE TYPE)
R322	YZ4100AB3910T0	CARBON FILM RESISTOR 390 OHM 1/6W +/-5% (TAPE TYPE)
R385	YZ4100AB3930T0	CARBON FILM RESISTOR 39K OHM 1/16-1/6W+/-5% (TAPE TYPE)
R411	YZ4100AB3930T0	CARBON FILM RESISTOR 39K OHM 1/16-1/6W+/-5% (TAPE TYPE)
R355	YZ4100AB4700T0	CARBON FILM RESISTOR 47 OHM 1/16-1/6W+/-5% (TAPE TYPE)
R370	YZ4100AB4700T0	CARBON FILM RESISTOR 47 OHM 1/16-1/6W+/-5% (TAPE TYPE)
R708	YZ4100AB4700T0	CARBON FILM RESISTOR 47 OHM 1/16-1/6W+/-5% (TAPE TYPE)
R308	YZ4100AB4710T0	CARBON FILM RESISTOR 470 OHM 1/16-1/6W+/-5% (TAPE TYPE)
R306	YZ4100AB4720T0	CARBON FILM RESISTOR 4.7K OHM 1/16-1/6W+/-5% (TAPE TYPE)
R356	YZ4100AB4720T0	CARBON FILM RESISTOR 4.7K OHM 1/16-1/6W+/-5% (TAPE TYPE)
R357	YZ4100AB4720T0	CARBON FILM RESISTOR 4.7K OHM 1/16-1/6W+/-5% (TAPE TYPE)
R462	YZ4100AB4720T0	CARBON FILM RESISTOR 4.7K OHM 1/16-1/6W+/-5% (TAPE TYPE)
R734	YZ4100AB4720T0	CARBON FILM RESISTOR 4.7K OHM 1/16-1/6W+/-5% (TAPE TYPE)
R736	YZ4100AB4720T0	CARBON FILM RESISTOR 4.7K OHM 1/16-1/6W+/-5% (TAPE TYPE)
R776	YZ4100AB4720T0	CARBON FILM RESISTOR 4.7K OHM 1/16-1/6W+/-5% (TAPE TYPE)
R814	YZ4100AB4720T0	CARBON FILM RESISTOR 4.7K OHM 1/16-1/6W+/-5% (TAPE TYPE)
R815	YZ4100AB4720T0	CARBON FILM RESISTOR 4.7K OHM 1/16-1/6W+/-5% (TAPE TYPE)
R465	YZ4100AB5640T0	CARBON FILM RESISTOR 560K OHM 1/16-1/6W+/-5% (TAPE TYPE)
R304	YZ4100AB6800T0	CARBON FILM RESISTOR 68 OHM 1/16-1/6W+/-5% (TAPE TYPE)
R319	YZ4100AB6810T0	CARBON FILM RESISTOR 680 OHM 1/16-1/6W+/-5% (TAPE TYPE)
R482	YZ4100AB6810T0	CARBON FILM RESISTOR 680 OHM 1/16-1/6W+/-5% (TAPE TYPE)
R310	YZ4100AB7500T0	CARBON FILM RESISTOR 75 OHM 1/16-1/6W+/-5% (TAPE TYPE)
R835	YZ4100AB7500T0	CARBON FILM RESISTOR 75 OHM 1/16-1/6W+/-5% (TAPE TYPE)
R836	YZ4100AB7500T0	CARBON FILM RESISTOR 75 OHM 1/16-1/6W+/-5% (TAPE TYPE)
R837	YZ4100AB7500T0	CARBON FILM RESISTOR 75 OHM 1/16-1/6W+/-5% (TAPE TYPE)
R313	YZ4100AB8220T0	CARBON FILM RESISTOR 8.2K OHM 1/16-1/6W+/-5% (TAPE TYPE)
R864	YZ4100AB8220T0	CARBON FILM RESISTOR 8.2K OHM 1/16-1/6W+/-5% (TAPE TYPE)
R404	YZ4100AD0100T0	CARBON FILM RESISTOR 1 OHM 1/4W +/-5%(TAPE TYPE)
R640	YZ4100AD1020T0	CARBON FILM RESISTOR 1K OHM 1/4W +/-5% (TAPE TYPE)
R486	YZ4100AD3620T0	CARBON FILM RESISTOR 3.6K OHM 1/4W +/-5% (TAPE TYPE)
R613	YZ4100AD3620T0	CARBON FILM RESISTOR 3.6K OHM 1/4W +/-5% (TAPE TYPE)
R642	YZ4100AD5130T0	CARBON FILM RESISTOR 51K OHM 1/4W +/-5%(TAPE TYPE)
R643	YZ4100AD5130T0	CARBON FILM RESISTOR 51K OHM 1/4W +/-5%(TAPE TYPE)
R474	YZ4100AF2240T0	CARBON FILM RESISTOR 220K OHM 1/2W +/-5% (TAPE TYPE)
R453	YZ4100BF2720T0	CARBON COMPOSITION RESISTOR 2.7K OHM 1/2W +/-5% (TAPE TYPE)
R610	YZ4100BF2720T0	CARBON COMPOSITION RESISTOR 2.7K OHM 1/2W +/-5% (TAPE TYPE)
R611	YZ4100BF2720T0	CARBON COMPOSITION RESISTOR 2.7K OHM 1/2W +/-5% (TAPE TYPE)
C151	YZ4300AF101CT0	CERAMIC CAPACITOR 100PF 50V +/-5% (TAPETYPE)
C152	YZ4300AF101CT0	CERAMIC CAPACITOR 100PF 50V +/-5% (TAPETYPE)
C407	YZ4300AF101CT0	CERAMIC CAPACITOR 100PF 50V +/-5% (TAPETYPE)
C708	YZ4300AF101CT0	CERAMIC CAPACITOR 100PF 50V +/-5% (TAPETYPE)
C721	YZ4300AF101CT0	CERAMIC CAPACITOR 100PF 50V +/-5% (TAPETYPE)
C722	YZ4300AF101CT0	CERAMIC CAPACITOR 100PF 50V +/-5% (TAPETYPE)
C879	YZ4300AF101CT0	CERAMIC CAPACITOR 100PF 50V +/-5% (TAPETYPE)

ELECTRICAL PARTS LIST

FOR REFERENCE ONLY

Circuit No	Part No	Description
C880	YZ4300AF101CT0	CERAMIC CAPACITOR 100PF 50V +/-5% (TAPETYPE)
C308	YZ4300AF102CT0	CERAMIC CAPACITOR 0.001uF 50V +/-5% (TAPE TYPE)
C309	YZ4300AF102CT0	CERAMIC CAPACITOR 0.001uF 50V +/-5% (TAPE TYPE)
C310	YZ4300AF102CT0	CERAMIC CAPACITOR 0.001uF 50V +/-5% (TAPE TYPE)
C311	YZ4300AF102CT0	CERAMIC CAPACITOR 0.001uF 50V +/-5% (TAPE TYPE)
C315	YZ4300AF102CT0	CERAMIC CAPACITOR 0.001uF 50V +/-5% (TAPE TYPE)
C366	YZ4300AF102CT0	CERAMIC CAPACITOR 0.001uF 50V +/-5% (TAPE TYPE)
C401	YZ4300AF102CT0	CERAMIC CAPACITOR 0.001uF 50V +/-5% (TAPE TYPE)
C402	YZ4300AF102CT0	CERAMIC CAPACITOR 0.001uF 50V +/-5% (TAPE TYPE)
C450	YZ4300AF102CT0	CERAMIC CAPACITOR 0.001uF 50V +/-5% (TAPE TYPE)
C481	YZ4300AF102CT0	CERAMIC CAPACITOR 0.001uF 50V +/-5% (TAPE TYPE)
C802	YZ4300AF102CT0	CERAMIC CAPACITOR 0.001uF 50V +/-5% (TAPE TYPE)
C803	YZ4300AF102CT0	CERAMIC CAPACITOR 0.001uF 50V +/-5% (TAPE TYPE)
C807	YZ4300AF102CT0	CERAMIC CAPACITOR 0.001uF 50V +/-5% (TAPE TYPE)
C808	YZ4300AF102CT0	CERAMIC CAPACITOR 0.001uF 50V +/-5% (TAPE TYPE)
C842	YZ4300AF102CT0	CERAMIC CAPACITOR 0.001uF 50V +/-5% (TAPE TYPE)
C844	YZ4300AF102CT0	CERAMIC CAPACITOR 0.001uF 50V +/-5% (TAPE TYPE)
C125	YZ4300AF103HT0	CERAMIC CAPACITOR 0.01uF 50V +80-20% (TAPE TYPE)
C172	YZ4300AF103HT0	CERAMIC CAPACITOR 0.01uF 50V +80-20% (TAPE TYPE)
C312	YZ4300AF103HT0	CERAMIC CAPACITOR 0.01uF 50V +80-20% (TAPE TYPE)
C327	YZ4300AF103HT0	CERAMIC CAPACITOR 0.01uF 50V +80-20% (TAPE TYPE)
C332	YZ4300AF103HT0	CERAMIC CAPACITOR 0.01uF 50V +80-20% (TAPE TYPE)
C362	YZ4300AF103HT0	CERAMIC CAPACITOR 0.01uF 50V +80-20% (TAPE TYPE)
C470	YZ4300AF103HT0	CERAMIC CAPACITOR 0.01uF 50V +80-20% (TAPE TYPE)
C475	YZ4300AF103HT0	CERAMIC CAPACITOR 0.01uF 50V +80-20% (TAPE TYPE)
C608	YZ4300AF103HT0	CERAMIC CAPACITOR 0.01uF 50V +80-20% (TAPE TYPE)
C672	YZ4300AF103HT0	CERAMIC CAPACITOR 0.01uF 50V +80-20% (TAPE TYPE)
C723	YZ4300AF103HT0	CERAMIC CAPACITOR 0.01uF 50V +80-20% (TAPE TYPE)
C752	YZ4300AF103HT0	CERAMIC CAPACITOR 0.01uF 50V +80-20% (TAPE TYPE)
C753	YZ4300AF103HT0	CERAMIC CAPACITOR 0.01uF 50V +80-20% (TAPE TYPE)
C756	YZ4300AF103HT0	CERAMIC CAPACITOR 0.01uF 50V +80-20% (TAPE TYPE)
C871	YZ4300AF103HT0	CERAMIC CAPACITOR 0.01uF 50V +80-20% (TAPE TYPE)
C872	YZ4300AF103HT0	CERAMIC CAPACITOR 0.01uF 50V +80-20% (TAPE TYPE)
C405	YZ4300AF150CT0	CERAMIC CAPACITOR 15PF 50V +/-5% (TAPE TYPE)
C335	YZ4300AF222HT0	CERAMIC CAPACITOR 0.0022uF 50V +80-20% (TAPE TYPE)
C704	YZ4300AF330CT0	CERAMIC CAPACITOR 33PF 50V +/-5% (TAPETYPE)
C761	YZ4300AF330CT0	CERAMIC CAPACITOR 33PF 50V +/-5% (TAPETYPE)
C762	YZ4300AF330CT0	CERAMIC CAPACITOR 33PF 50V +/-5% (TAPETYPE)
C861	YZ4300AF470CT0	CERAMIC CAPACITOR 47PF 50V +/-5% (TAPE TYPE)
C336	YZ4300AF472HT0	CERAMIC CAPACITOR 0.0047uF 50V +80-20% (TAPE TYPE)
C381	YZ4300AF561CT0	CERAMIC CAPACITOR 560PF 50V +/-5% (TAPETYPE)
C612	YZ4300AF561CT0	CERAMIC CAPACITOR 560PF 50V +/-5% (TAPETYPE)
C482	YZ4300AM221DT0	CERAMIC CAPACITOR 220PF 500V +/-10% (TAPE TYPE)
C451	YZ4300AM222DT0	CERAMIC CAPACITOR 0.0022uF 500V +/-10% (TAPE TYPE)
C471	YZ4300AM471DT0	CERAMIC CAPACITOR 470PF 500V +/-10% (TAPE TYPE)
C472	YZ4300AM471DT0	CERAMIC CAPACITOR 470PF 500V +/-10% (TAPE TYPE)
C473	YZ4300AM471DT0	CERAMIC CAPACITOR 470PF 500V +/-10% (TAPE TYPE)
C476	YZ4300AM471DT0	CERAMIC CAPACITOR 470PF 500V +/-10% (TAPE TYPE)
C603	YZ4300AR472E00	CERAMIC CAPACITOR 0.0047uF 1KV +/-20%(TAPE TYPE)
C609	YZ4300AM103DC1	CERAMIC CAPACITOR 0.01uF 500V +/-10%(PITCH=7.5mm)
C609A	YZ4300AM103DC1	CERAMIC CAPACITOR 0.01uF 500V +/-10%(PITCH=7.5mm)

ELECTRICAL PARTS LIST

FOR REFERENCE ONLY

Circuit No	Part No	Description
C604	YZ4300AR472E00	CERAMIC CAPACITOR 0.0047uF 1KV +/-20%(TAPE TYPE)
C605	YZ4300AR472E00	CERAMIC CAPACITOR 0.0047uF 1KV +/-20%(TAPE TYPE)
C606	YZ4300AR472E00	CERAMIC CAPACITOR 0.0047uF 1KV +/-20%(TAPE TYPE)
C643	YZ4300AR471DT0	CERAMIC CAPACITOR 470PF 1KV +/-10% (TAPETYPE)
C644	YZ4300AR471DT0	CERAMIC CAPACITOR 470PF 1KV +/-10% (TAPETYPE)
C645	YZ4300AR471DT0	CERAMIC CAPACITOR 470PF 1KV +/-10% (TAPETYPE)
C303	YZ4300NF101CT0	NPO CERAMIC CAPACITOR 100PF 50V +/-5%(TAPE TYPE)
C305	YZ4300NF101CT0	NPO CERAMIC CAPACITOR 100PF 50V +/-5%(TAPE TYPE)
C307	YZ4300BC106ET0	ELECTROLYTIC CAPACITOR 10UF 16V +/-20%(TAPE TYPE)
C333	YZ4300BC106ET0	ELECTROLYTIC CAPACITOR 10UF 16V +/-20%(TAPE TYPE)
C364	YZ4300BC106ET0	ELECTROLYTIC CAPACITOR 10UF 16V +/-20%(TAPE TYPE)
C367	YZ4300BC106ET0	ELECTROLYTIC CAPACITOR 10UF 16V +/-20%(TAPE TYPE)
C751	YZ4300BC106ET0	ELECTROLYTIC CAPACITOR 10UF 16V +/-20%(TAPE TYPE)
C754	YZ4300BC106ET0	ELECTROLYTIC CAPACITOR 10UF 16V +/-20%(TAPE TYPE)
C818	YZ4300BC106ET0	ELECTROLYTIC CAPACITOR 10UF 16V +/-20%(TAPE TYPE)
C841	YZ4300BC106ET0	ELECTROLYTIC CAPACITOR 10UF 16V +/-20%(TAPE TYPE)
C846	YZ4300BC106ET0	ELECTROLYTIC CAPACITOR 10UF 16V +/-20%(TAPE TYPE)
C122	YZ4300BC107ET0	ELECTROLYTIC CAPACITOR 100uF 16V +/-20%(TAPE TYPE)
C171	YZ4300BC107ET0	ELECTROLYTIC CAPACITOR 100uF 16V +/-20%(TAPE TYPE)
C173	YZ4300BC107ET0	ELECTROLYTIC CAPACITOR 100uF 16V +/-20%(TAPE TYPE)
C181	YZ4300BC107ET0	ELECTROLYTIC CAPACITOR 100uF 16V +/-20%(TAPE TYPE)
C320	YZ4300BC107ET0	ELECTROLYTIC CAPACITOR 100uF 16V +/-20%(TAPE TYPE)
C361	YZ4300BC107ET0	ELECTROLYTIC CAPACITOR 100uF 16V +/-20%(TAPE TYPE)
C669	YZ4300BC107ET0	ELECTROLYTIC CAPACITOR 100uF 16V +/-20%(TAPE TYPE)
C671	YZ4300BC107ET0	ELECTROLYTIC CAPACITOR 100uF 16V +/-20%(TAPE TYPE)
C865	YZ4300BC107ET0	ELECTROLYTIC CAPACITOR 100uF 16V +/-20%(TAPE TYPE)
C126	YZ4300BC476ET0	ELECTROLYTIC CAPACITOR 47uF 16V +/-20% (TAPE TYPE)
C352	YZ4300BC476ET0	ELECTROLYTIC CAPACITOR 47uF 16V +/-20% (TAPE TYPE)
C668	YZ4300BC476ET0	ELECTROLYTIC CAPACITOR 47uF 16V +/-20% (TAPE TYPE)
C724	YZ4300BC476ET0	ELECTROLYTIC CAPACITOR 47uF 16V +/-20% (TAPE TYPE)
C806	YZ4300BC476ET0	ELECTROLYTIC CAPACITOR 47uF 16V +/-20% (TAPE TYPE)
C847	YZ4300BC476ET0	ELECTROLYTIC CAPACITOR 47uF 16V +/-20% (TAPE TYPE)
C876	YZ4300BC476ET0	ELECTROLYTIC CAPACITOR 47uF 16V +/-20% (TAPE TYPE)
C474	YZ4300BD107ET0	ELECTROLYTIC CAPACITOR 100uF 25V +/-20%(TAPE TYPE)
C653	YZ4300BD477ET0	ELECTROLYTIC CAPACITOR 470uF 25V +/-20%(TAPE TYPE)
C654	YZ4300BD477ET0	ELECTROLYTIC CAPACITOR 470uF 25V +/-20%(TAPE TYPE)
C667	YZ4300BD477ET0	ELECTROLYTIC CAPACITOR 470uF 25V +/-20%(TAPE TYPE)
C801	YZ4300BD477ET0	ELECTROLYTIC CAPACITOR 470uF 25V +/-20%(TAPE TYPE)
C406	YZ4300BE107ET0	ELECTROLYTIC CAPACITOR 100uF 35V +/-20%(TAPE TYPE)
C703	YZ4300BE476ET0	ELECTROLYTIC CAPACITOR 47uF 35V +/-20% (TAPE TYPE)
C153	YZ4300BF105ET0	ELECTROLYTIC CAPACITOR 1uF 50V +/-20% (TAPE TYPE)
C157	YZ4300BF105ET0	ELECTROLYTIC CAPACITOR 1uF 50V +/-20% (TAPE TYPE)
C160	YZ4300BF105ET0	ELECTROLYTIC CAPACITOR 1uF 50V +/-20% (TAPE TYPE)
C167	YZ4300BF105ET0	ELECTROLYTIC CAPACITOR 1uF 50V +/-20% (TAPE TYPE)
C337	YZ4300BF105ET0	ELECTROLYTIC CAPACITOR 1uF 50V +/-20% (TAPE TYPE)
C804	YZ4300BF105ET0	ELECTROLYTIC CAPACITOR 1uF 50V +/-20% (TAPE TYPE)
C805	YZ4300BF105ET0	ELECTROLYTIC CAPACITOR 1uF 50V +/-20% (TAPE TYPE)
C809	YZ4300BF105ET0	ELECTROLYTIC CAPACITOR 1uF 50V +/-20% (TAPE TYPE)
C810	YZ4300BF105ET0	ELECTROLYTIC CAPACITOR 1uF 50V +/-20% (TAPE TYPE)
C843	YZ4300BF105ET0	ELECTROLYTIC CAPACITOR 1uF 50V +/-20% (TAPE TYPE)
C845	YZ4300BF105ET0	ELECTROLYTIC CAPACITOR 1uF 50V +/-20% (TAPE TYPE)

ELECTRICAL PARTS LIST

FOR REFERENCE ONLY

Circuit No	Part No	Description
C863	YZ4300BF105ET0	ELECTROLYTIC CAPACITOR 1uF 50V +/-20% (TAPE TYPE)
C324	YZ4300BF225ET0	ELECTROLYTIC CAPACITOR 2.2uF 50V +/-20%(TAPE TYPE)
C328	YZ4300BF225ET0	ELECTROLYTIC CAPACITOR 2.2uF 50V +/-20%(TAPE TYPE)
C339	YZ4300BF225ET0	ELECTROLYTIC CAPACITOR 2.2uF 50V +/-20%(TAPE TYPE)
C755	YZ4300BF225ET0	ELECTROLYTIC CAPACITOR 2.2uF 50V +/-20%(TAPE TYPE)
C873	YZ4300BF225ET0	ELECTROLYTIC CAPACITOR 2.2uF 50V +/-20%(TAPE TYPE)
C874	YZ4300BF225ET0	ELECTROLYTIC CAPACITOR 2.2uF 50V +/-20%(TAPE TYPE)
C462	YZ4300BF475ET0	ELECTROLYTIC CAPACITOR 4.7uF 50V-100V +/-20% (TAPE TYPE)
C464	YZ4300BF475ET0	ELECTROLYTIC CAPACITOR 4.7uF 50V-100V +/-20% (TAPE TYPE)
C610	YZ4300BF476ET0	ELECTROLYTIC CAPACITOR 47uF 50V +/-20% (TAPE TYPE)
C453	YZ4300BH105ET0	ELECTROLYTIC CAPACITOR 1UF 160V +/-20%(TAPE TYPE)
C466	YZ4300BH475ET0	ELECTROLYTIC CAPACITOR 4.7uF 160V +/-20%(TAPE TYPE)
C128	YZ4300EF104CT0	METALLIZED POLYESTER FILM CAPACITOR 0.1UF 63-100V +/-5% (TAPE TYPE)
C133	YZ4300EF104CT0	METALLIZED POLYESTER FILM CAPACITOR 0.1UF 63-100V +/-5% (TAPE TYPE)
C326	YZ4300EF104CT0	METALLIZED POLYESTER FILM CAPACITOR 0.1UF 63-100V +/-5% (TAPE TYPE)
C338	YZ4300EF104CT0	METALLIZED POLYESTER FILM CAPACITOR 0.1UF 63-100V +/-5% (TAPE TYPE)
C365	YZ4300EF104CT0	METALLIZED POLYESTER FILM CAPACITOR 0.1UF 63-100V +/-5% (TAPE TYPE)
C411	YZ4300EF104CT0	METALLIZED POLYESTER FILM CAPACITOR 0.1UF 63-100V +/-5% (TAPE TYPE)
C460	YZ4300EF104CT0	METALLIZED POLYESTER FILM CAPACITOR 0.1UF 63-100V +/-5% (TAPE TYPE)
C619	YZ4300EF104CT0	METALLIZED POLYESTER FILM CAPACITOR 0.1UF 63-100V +/-5% (TAPE TYPE)
C864	YZ4300EF104CT0	METALLIZED POLYESTER FILM CAPACITOR 0.1UF 63-100V +/-5% (TAPE TYPE)
C165	YZ4300EF224CT0	METALLIZED POLYESTER FILM CAPACITOR 0.22UF 63-100V +/-5% (TAPE TYPE)
C166	YZ4300EF224CT0	METALLIZED POLYESTER FILM CAPACITOR 0.22UF 63-100V +/-5% (TAPE TYPE)
C331	YZ4300EF224CT0	METALLIZED POLYESTER FILM CAPACITOR 0.22UF 63-100V +/-5% (TAPE TYPE)
C334	YZ4300EF224CT0	METALLIZED POLYESTER FILM CAPACITOR 0.22UF 63-100V +/-5% (TAPE TYPE)
C404	YZ4300EF224CT0	METALLIZED POLYESTER FILM CAPACITOR 0.22UF 63-100V +/-5% (TAPE TYPE)
C457	YZ4300EF474CT0	METALLIZED POLYESTER FILM CAPACITOR 0.47uF 63-100V +/-5% (TAPE TYPE)
C862	YZ4300EF474CT0	METALLIZED POLYESTER FILM CAPACITOR 0.47uF 63-100V +/-5% (TAPE TYPE)
C866	YZ4300EF474CT0	METALLIZED POLYESTER FILM CAPACITOR 0.47uF 63-100V +/-5% (TAPE TYPE)
C868	YZ4300EF474CT0	METALLIZED POLYESTER FILM CAPACITOR 0.47uF 63-100V +/-5% (TAPE TYPE)
C869	YZ4300EF474CT0	METALLIZED POLYESTER FILM CAPACITOR 0.47uF 63-100V +/-5% (TAPE TYPE)
C870	YZ4300EF474CT0	METALLIZED POLYESTER FILM CAPACITOR 0.47uF 63-100V +/-5% (TAPE TYPE)
C875	YZ4300EF474CT0	METALLIZED POLYESTER FILM CAPACITOR 0.47uF 63-100V +/-5% (TAPE TYPE)
C878	YZ4300EF474CT0	METALLIZED POLYESTER FILM CAPACITOR 0.47uF 63-100V +/-5% (TAPE TYPE)
C154	YZ4300MG103DT0	MYLAR CAPACITOR 0.01UF 100V +/-10% (TAPE TYPE)
C158	YZ4300MG103DT0	MYLAR CAPACITOR 0.01UF 100V +/-10% (TAPE TYPE)
C164	YZ4300MG103DT0	MYLAR CAPACITOR 0.01UF 100V +/-10% (TAPE TYPE)
C135	YZ4300MG153DT0	MYLAR CAPACITOR 0.015UF 100V +/-10% (TAPE TYPE)
C136	YZ4300MG153DT0	MYLAR CAPACITOR 0.015UF 100V +/-10% (TAPE TYPE)
C313	YZ4300MG223DT0	MYLAR CAPACITOR 0.022uF 100V +/-10% (TAPE TYPE)
C372	YZ4300MG223DT0	MYLAR CAPACITOR 0.022uF 100V +/-10% (TAPE TYPE)
C373	YZ4300MG223DT0	MYLAR CAPACITOR 0.022uF 100V +/-10% (TAPE TYPE)
C374	YZ4300MG223DT0	MYLAR CAPACITOR 0.022uF 100V +/-10% (TAPE TYPE)
C403	YZ4300MG333DT0	MYLAR CAPACITOR 0.033uF 100V +/-10% (TAPE TYPE)
C408	YZ4300MG333DT0	MYLAR CAPACITOR 0.033uF 100V +/-10% (TAPE TYPE)
C618	YZ4300MG333DT0	MYLAR CAPACITOR 0.033uF 100V +/-10% (TAPE TYPE)
C660	YZ4300MG333DT0	MYLAR CAPACITOR 0.033uF 100V +/-10% (TAPE TYPE)

ELECTRICAL PARTS LIST

FOR REFERENCE ONLY

Circuit No	Part No	Description
C130	YZ4300MG682DT0	MYLAR CAPACITOR 0.0068uF 100V +/-10% (TAPE TYPE)
C131	YZ4300MG682DT0	MYLAR CAPACITOR 0.0068uF 100V +/-10% (TAPE TYPE)
C127	YZ4300MG683DT0	MYLAR CAPACITOR 0.068UF 100V +/-10% (TAPE TYPE)
C134	YZ4300MG683DT0	MYLAR CAPACITOR 0.068UF 100V +/-10% (TAPE TYPE)
D172	YZ4500141481T0	NORMAL RECTIFIER DIODE 1N4148 150mA/100V(TAPE TYPE)
D173	YZ4500141481T0	NORMAL RECTIFIER DIODE 1N4148 150mA/100V(TAPE TYPE)
D301	YZ4500141481T0	NORMAL RECTIFIER DIODE 1N4148 150mA/100V(TAPE TYPE)
D303	YZ5900G4010600	COPPER JUMPER 0.6MM DIA. L=40mm
D461	YZ4500141481T0	NORMAL RECTIFIER DIODE 1N4148 150mA/100V(TAPE TYPE)
D462	YZ4500141481T0	NORMAL RECTIFIER DIODE 1N4148 150mA/100V(TAPE TYPE)
D482	YZ4500141481T0	NORMAL RECTIFIER DIODE 1N4148 150mA/100V(TAPE TYPE)
D611	YZ4500141481T0	NORMAL RECTIFIER DIODE 1N4148 150mA/100V(TAPE TYPE)
D646	YZ4500141481T0	NORMAL RECTIFIER DIODE 1N4148 150mA/100V(TAPE TYPE)
D647	YZ4500141481T0	NORMAL RECTIFIER DIODE 1N4148 150mA/100V(TAPE TYPE)
D648	YZ4500141481T0	NORMAL RECTIFIER DIODE 1N4148 150mA/100V(TAPE TYPE)
D401	YZ4500215800T0	HIGH SPEED RECTIFIER DIODE BA158 600V/1A(TAPE TYPE)
D463	YZ4500215800T0	HIGH SPEED RECTIFIER DIODE BA158 600V/1A(TAPE TYPE)
D470	YZ4500215800T0	HIGH SPEED RECTIFIER DIODE BA158 600V/1A(TAPE TYPE)
D471	YZ4500215800T0	HIGH SPEED RECTIFIER DIODE BA158 600V/1A(TAPE TYPE)
D472	YZ4500215800T0	HIGH SPEED RECTIFIER DIODE BA158 600V/1A(TAPE TYPE)
D607	YZ4500215800T0	HIGH SPEED RECTIFIER DIODE BA158 600V/1A(TAPE TYPE)
D610	YZ4500215800T0	HIGH SPEED RECTIFIER DIODE BA158 600V/1A(TAPE TYPE)
D612	YZ4500215800T0	HIGH SPEED RECTIFIER DIODE BA158 600V/1A(TAPE TYPE)
D608	YZ4500400051T0	ZENER DIODE 5V1 1/2W (TAPE TYPE)
D613	YZ4500400051T0	ZENER DIODE 5V1 1/2W (TAPE TYPE)
D171	YZ4500400082T0	ZENER DIODE 8V2 1/2W (TAPE TYPE)
D381	YZ4500400082T0	ZENER DIODE 8V2 1/2W (TAPE TYPE)
D382	YZ4500400082T0	ZENER DIODE 8V2 1/2W (TAPE TYPE)
D383	YZ4500400082T0	ZENER DIODE 8V2 1/2W (TAPE TYPE)
D483	YZ4500400082T0	ZENER DIODE 8V2 1/2W (TAPE TYPE)
D702	YZ4500400082T0	ZENER DIODE 8V2 1/2W (TAPE TYPE)
D802	YZ4500400082T0	ZENER DIODE 8V2 1/2W (TAPE TYPE)
D803	YZ4500400082T0	ZENER DIODE 8V2 1/2W (TAPE TYPE)
D806	YZ4500400082T0	ZENER DIODE 8V2 1/2W (TAPE TYPE)
D832	YZ4500400082T0	ZENER DIODE 8V2 1/2W (TAPE TYPE)
D833	YZ4500400082T0	ZENER DIODE 8V2 1/2W (TAPE TYPE)
D834	YZ4500400082T0	ZENER DIODE 8V2 1/2W (TAPE TYPE)
D841	YZ4500400082T0	ZENER DIODE 8V2 1/2W (TAPE TYPE)
D481	YZ4500400180T0	ZENER DIODE 18V 1/2W (TAPE TYPE)
D614	YZ4500400330T5	ZENER DIODE 33V 1/2W +/-5%
Q172	YZ4600A10150T0	TRANSISTOR 2SA1015Y2PA1015 (TAPE TYPE)
Q171	YZ4600C18150T0	TRANSISTOR 2SC1815Y/2PC1815 (TAPE TYPE)
Q173	YZ4600C18150T0	TRANSISTOR 2SC1815Y/2PC1815 (TAPE TYPE)
Q301	YZ4600C18150T0	TRANSISTOR 2SC1815Y/2PC1815 (TAPE TYPE)
Q351	YZ4600C18150T0	TRANSISTOR 2SC1815Y/2PC1815 (TAPE TYPE)
Q352	YZ4600C18150T0	TRANSISTOR 2SC1815Y/2PC1815 (TAPE TYPE)
Q353	YZ4600C18150T0	TRANSISTOR 2SC1815Y/2PC1815 (TAPE TYPE)
Q354	YZ4600C18150T0	TRANSISTOR 2SC1815Y/2PC1815 (TAPE TYPE)
Q640	YZ4600C18150T0	TRANSISTOR 2SC1815Y/2PC1815 (TAPE TYPE)
Q702	YZ4600C18150T0	TRANSISTOR 2SC1815Y/2PC1815 (TAPE TYPE)

ELECTRICAL PARTS LIST

FOR REFERENCE ONLY

Circuit No	Part No	Description
Q812	YZ4600C18150T0	TRANSISTOR 2SC1815Y/2PC1815 (TAPE TYPE)
Q813	YZ4600C18150T0	TRANSISTOR 2SC1815Y/2PC1815 (TAPE TYPE)
Q841	YZ4600C18150T0	TRANSISTOR 2SC1815Y/2PC1815 (TAPE TYPE)
Q450	YZ4600C24822T0	TRANSISTOR 2SC2482/3DG2482Y (TAPE TYPE)
L302	YZ4800010100T0	PEAKING COIL 1uH +/-10% (TAPE TYPE)
L351	YZ4800010680T0	PEAKING COIL 6.8uH (TAPE TYPE)
L121	YZ4800011000T0	PEAKING COIL 10uH +/-10% (TAPE TYPE)
L301	YZ4800011000T0	PEAKING COIL 10uH +/-10% (TAPE TYPE)
L331	YZ4800011000T0	PEAKING COIL 10uH +/-10% (TAPE TYPE)
L362	YZ4800011000T0	PEAKING COIL 10uH +/-10% (TAPE TYPE)
L751	YZ4800011000T0	PEAKING COIL 10uH +/-10% (TAPE TYPE)
L752	YZ4800011000T0	PEAKING COIL 10uH +/-10% (TAPE TYPE)
L753	YZ4800011000T0	PEAKING COIL 10uH +/-10% (TAPE TYPE)
L801	YZ4800011000T0	PEAKING COIL 10uH +/-10% (TAPE TYPE)
L802	YZ4800011000T0	PEAKING COIL 10uH +/-10% (TAPE TYPE)
L861	YZ4800011000T0	PEAKING COIL 10uH +/-10% (TAPE TYPE)
L862	YZ4800011500T0	PEAKING COIL 15uH +/-10% (TAPE TYPE)
C325	YZ5900G4010600	COPPER JUMPER 0.6MM DIA. L=40mm
L454	YZ5900G4010600	COPPER JUMPER 0.6MM DIA. L=40mm
L455	YZ5900G4010600	COPPER JUMPER 0.6MM DIA. L=40mm
L603	YZ5900G4010600	COPPER JUMPER 0.6MM DIA. L=40mm
R321	YZ5900G4010600	COPPER JUMPER 0.6MM DIA. L=40mm
R463	YZ5900G4010600	COPPER JUMPER 0.6MM DIA. L=40mm
R832	YZ5900G4010600	COPPER JUMPER 0.6MM DIA. L=40mm
W021	YZ5900G4010600	COPPER JUMPER 0.6MM DIA. L=40mm
W121	YZ5900G4010600	COPPER JUMPER 0.6MM DIA. L=40mm
W122	YZ5900G4010600	COPPER JUMPER 0.6MM DIA. L=40mm
W141	YZ5900G4010600	COPPER JUMPER 0.6MM DIA. L=40mm
W201	YZ5900G4010600	COPPER JUMPER 0.6MM DIA. L=40mm
W211	YZ5900G4010600	COPPER JUMPER 0.6MM DIA. L=40mm
W221	YZ5900G4010600	COPPER JUMPER 0.6MM DIA. L=40mm
W222	YZ5900G4010600	COPPER JUMPER 0.6MM DIA. L=40mm
W223	YZ5900G4010600	COPPER JUMPER 0.6MM DIA. L=40mm
W231	YZ5900G4010600	COPPER JUMPER 0.6MM DIA. L=40mm
W232	YZ5900G4010600	COPPER JUMPER 0.6MM DIA. L=40mm
W233	YZ5900G4010600	COPPER JUMPER 0.6MM DIA. L=40mm
W234	YZ5900G4010600	COPPER JUMPER 0.6MM DIA. L=40mm
W241	YZ5900G4010600	COPPER JUMPER 0.6MM DIA. L=40mm
W301	YZ5900G4010600	COPPER JUMPER 0.6MM DIA. L=40mm
W302	YZ5900G4010600	COPPER JUMPER 0.6MM DIA. L=40mm
W311	YZ5900G4010600	COPPER JUMPER 0.6MM DIA. L=40mm
W312	YZ5900G4010600	COPPER JUMPER 0.6MM DIA. L=40mm
W321	YZ5900G4010600	COPPER JUMPER 0.6MM DIA. L=40mm
W331	YZ5900G4010600	COPPER JUMPER 0.6MM DIA. L=40mm
W332	YZ5900G4010600	COPPER JUMPER 0.6MM DIA. L=40mm
W411	YZ5900G4010600	COPPER JUMPER 0.6MM DIA. L=40mm
W412	YZ5900G4010600	COPPER JUMPER 0.6MM DIA. L=40mm
W413	YZ5900G4010600	COPPER JUMPER 0.6MM DIA. L=40mm
W414	YZ5900G4010600	COPPER JUMPER 0.6MM DIA. L=40mm

ELECTRICAL PARTS LIST

FOR REFERENCE ONLY

Circuit No	Part No	Description
W415	YZ5900G4010600	COPPER JUMPER 0.6MM DIA. L=40mm
W416	YZ5900G4010600	COPPER JUMPER 0.6MM DIA. L=40mm
W417	YZ5900G4010600	COPPER JUMPER 0.6MM DIA. L=40mm
W421	YZ5900G4010600	COPPER JUMPER 0.6MM DIA. L=40mm
W422	YZ5900G4010600	COPPER JUMPER 0.6MM DIA. L=40mm
W423	YZ5900G4010600	COPPER JUMPER 0.6MM DIA. L=40mm
W424	YZ5900G4010600	COPPER JUMPER 0.6MM DIA. L=40mm
W425	YZ5900G4010600	COPPER JUMPER 0.6MM DIA. L=40mm
W426	YZ5900G4010600	COPPER JUMPER 0.6MM DIA. L=40mm
W427	YZ5900G4010600	COPPER JUMPER 0.6MM DIA. L=40mm
W428	YZ5900G4010600	COPPER JUMPER 0.6MM DIA. L=40mm
W429	YZ5900G4010600	COPPER JUMPER 0.6MM DIA. L=40mm
W432	YZ5900G4010600	COPPER JUMPER 0.6MM DIA. L=40mm
W442	YZ5900G4010600	COPPER JUMPER 0.6MM DIA. L=40mm
W443	YZ5900G4010600	COPPER JUMPER 0.6MM DIA. L=40mm
W444	YZ5900G4010600	COPPER JUMPER 0.6MM DIA. L=40mm
W445	YZ5900G4010600	COPPER JUMPER 0.6MM DIA. L=40mm
W451	YZ5900G4010600	COPPER JUMPER 0.6MM DIA. L=40mm
W452	YZ5900G4010600	COPPER JUMPER 0.6MM DIA. L=40mm
W453	YZ5900G4010600	COPPER JUMPER 0.6MM DIA. L=40mm
W454	YZ5900G4010600	COPPER JUMPER 0.6MM DIA. L=40mm
W501	YZ5900G4010600	COPPER JUMPER 0.6MM DIA. L=40mm
W503	YZ5900G4010600	COPPER JUMPER 0.6MM DIA. L=40mm
W513	YZ5900G4010600	COPPER JUMPER 0.6MM DIA. L=40mm
W516	YZ5900G4010600	COPPER JUMPER 0.6MM DIA. L=40mm
W519	YZ5900G4010600	COPPER JUMPER 0.6MM DIA. L=40mm
W521	YZ5900G4010600	COPPER JUMPER 0.6MM DIA. L=40mm
W522	YZ5900G4010600	COPPER JUMPER 0.6MM DIA. L=40mm
W523	YZ5900G4010600	COPPER JUMPER 0.6MM DIA. L=40mm
W531	YZ5900G4010600	COPPER JUMPER 0.6MM DIA. L=40mm
W532	YZ5900G4010600	COPPER JUMPER 0.6MM DIA. L=40mm
W533	YZ5900G4010600	COPPER JUMPER 0.6MM DIA. L=40mm
W540	YZ5900G4010600	COPPER JUMPER 0.6MM DIA. L=40mm
W541	YZ5900G4010600	COPPER JUMPER 0.6MM DIA. L=40mm
W542	YZ5900G4010600	COPPER JUMPER 0.6MM DIA. L=40mm
W543	YZ5900G4010600	COPPER JUMPER 0.6MM DIA. L=40mm
W544	YZ5900G4010600	COPPER JUMPER 0.6MM DIA. L=40mm
W545	YZ5900G4010600	COPPER JUMPER 0.6MM DIA. L=40mm
W546	YZ5900G4010600	COPPER JUMPER 0.6MM DIA. L=40mm
W547	YZ5900G4010600	COPPER JUMPER 0.6MM DIA. L=40mm
W548	YZ5900G4010600	COPPER JUMPER 0.6MM DIA. L=40mm
W551	YZ5900G4010600	COPPER JUMPER 0.6MM DIA. L=40mm
W552	YZ5900G4010600	COPPER JUMPER 0.6MM DIA. L=40mm
W553	YZ5900G4010600	COPPER JUMPER 0.6MM DIA. L=40mm
W554	YZ5900G4010600	COPPER JUMPER 0.6MM DIA. L=40mm
W555	YZ5900G4010600	COPPER JUMPER 0.6MM DIA. L=40mm
W557	YZ5900G4010600	COPPER JUMPER 0.6MM DIA. L=40mm
W558	YZ5900G4010600	COPPER JUMPER 0.6MM DIA. L=40mm
W559	YZ5900G4010600	COPPER JUMPER 0.6MM DIA. L=40mm
W612	YZ5900G4010600	COPPER JUMPER 0.6MM DIA. L=40mm

ELECTRICAL PARTS LIST

FOR REFERENCE ONLY

Circuit No	Part No	Description
W613	YZ5900G4010600	COPPER JUMPER 0.6MM DIA. L=40mm
W616	YZ5900G4010600	COPPER JUMPER 0.6MM DIA. L=40mm
W621	YZ5900G4010600	COPPER JUMPER 0.6MM DIA. L=40mm
W622	YZ5900G4010600	COPPER JUMPER 0.6MM DIA. L=40mm
W624	YZ5900G4010600	COPPER JUMPER 0.6MM DIA. L=40mm
W625	YZ5900G4010600	COPPER JUMPER 0.6MM DIA. L=40mm
W626	YZ5900G4010600	COPPER JUMPER 0.6MM DIA. L=40mm
W631	YZ5900G4010600	COPPER JUMPER 0.6MM DIA. L=40mm
W634	YZ5900G4010600	COPPER JUMPER 0.6MM DIA. L=40mm
W640	YZ5900G4010600	COPPER JUMPER 0.6MM DIA. L=40mm
W642	YZ5900G4010600	COPPER JUMPER 0.6MM DIA. L=40mm
W643	YZ5900G4010600	COPPER JUMPER 0.6MM DIA. L=40mm
W644	YZ5900G4010600	COPPER JUMPER 0.6MM DIA. L=40mm
W645	YZ5900G4010600	COPPER JUMPER 0.6MM DIA. L=40mm
W647	YZ5900G4010600	COPPER JUMPER 0.6MM DIA. L=40mm
W648	YZ5900G4010600	COPPER JUMPER 0.6MM DIA. L=40mm
W649	YZ5900G4010600	COPPER JUMPER 0.6MM DIA. L=40mm
W651	YZ5900G4010600	COPPER JUMPER 0.6MM DIA. L=40mm
W652	YZ5900G4010600	COPPER JUMPER 0.6MM DIA. L=40mm
W653	YZ5900G4010600	COPPER JUMPER 0.6MM DIA. L=40mm
W721	YZ5900G4010600	COPPER JUMPER 0.6MM DIA. L=40mm
W722	YZ5900G4010600	COPPER JUMPER 0.6MM DIA. L=40mm
W723	YZ5900G4010600	COPPER JUMPER 0.6MM DIA. L=40mm
W732	YZ5900G4010600	COPPER JUMPER 0.6MM DIA. L=40mm
W742	YZ5900G4010600	COPPER JUMPER 0.6MM DIA. L=40mm
W743	YZ5900G4010600	COPPER JUMPER 0.6MM DIA. L=40mm
W744A	YZ5900G4010600	COPPER JUMPER 0.6MM DIA. L=40mm
W752	YZ5900G4010600	COPPER JUMPER 0.6MM DIA. L=40mm
W751	YZ5900G4010600	COPPER JUMPER 0.6MM DIA. L=40mm
013PAST001H0M		MAIN ASSEMBLY (MANUAL INSERT)
R406	YZ4100DG010001	METAL OXIDE FILM RESISTOR 1 OHM 1W 5%
R473	YZ4100DG010001	METAL OXIDE FILM RESISTOR 1 OHM 1W 5%
R612	YZ4100DG047001	METAL OXIDE FILM RESISTOR 4.7 OHM 1W +/-5%
R466	YZ4100DG102001	METAL OXIDE FILM RESISTOR 1K OHM 1W +/-5%
R467	YZ4100DG103001	METAL OXIDE FILM RESISTOR 10K OHM 1W +/-5%
R407	YZ4100DG271001	METAL OXIDE FILM RESISTOR 270 OHM 1W +/-5%
R674	YZ4100DG330001	METAL OXIDE FILM RESISTOR 33 OHM 1W +/-5%
R675	YZ4100DG330001	METAL OXIDE FILM RESISTOR 33 OHM 1W +/-5%
R485	YZ4100DG472001	METAL OXIDE FILM RESISTOR 4.7K OHM 1W +/-5%
R470	YZ4100DH002201	METAL OXIDE FILM RESISTOR 0.22 OHM 2W +/-5%
R472	YZ4100DH002201	METAL OXIDE FILM RESISTOR 0.22 OHM 2W +/-5%
R691	YZ4100DH002201	METAL OXIDE FILM RESISTOR 0.22 OHM 2W +/-5%
R693	YZ4100DH002201	METAL OXIDE FILM RESISTOR 0.22 OHM 2W +/-5%
R601	YZ4100DH223001	METAL OXIDE FILM RESISTOR 22K OHM 2W +/-5%
R703	YZ4100DH223001	METAL OXIDE FILM RESISTOR 22K OHM 2W +/-5%
R458	YZ4100FK040000	WIRE WOUND RESISTOR 4 OHM 5W +/-5%
R602	YZ4100NJ047000	NTC THERMISTOR RESISTOR 4.7 OHM 5.1A
R629	YZ4101HG8250T0	HIGH-VOLT RESISTOR 8.2M OHM 1W +/-5%(TAPE TYPE)



ELECTRICAL PARTS LIST

FOR REFERENCE ONLY

Circuit No	Part No	Description
VR641	YZ420021030000	SEMI-FIXED RESISTOR 10KB (H) KVSF637ASB KOAOHM
C643	YZ4300AR471DT0	CERAMIC CAPACITOR 470PF 1KV +/-10% (TAPETYPE)
C644	YZ4300AR471DT0	CERAMIC CAPACITOR 470PF 1KV +/-10% (TAPETYPE)
C645	YZ4300AR471DT0	CERAMIC CAPACITOR 470PF 1KV +/-10% (TAPETYPE)
C603	YZ4300AR472E00	CERAMIC CAPACITOR 0.0047uF 1KV +/-20%
C604	YZ4300AR472E00	CERAMIC CAPACITOR 0.0047uF 1KV +/-20%
C605	YZ4300AR472E00	CERAMIC CAPACITOR 0.0047uF 1KV +/-20%
C606	YZ4300AR472E00	CERAMIC CAPACITOR 0.0047uF 1KV +/-20%
C615	YZ4300AT102D00H	CERAMIC CAPACITOR 0.001uF 2KV +/-10%
C482	YZ4300AT221D00H	CERAMIC CAPACITOR 220PF 2KV +/-10%
C641	YZ4300AT221D00H	CERAMIC CAPACITOR 220PF 2KV +/-10%
C163	YZ4300BD108E00	ELECTROLYTIC CAPACITOR 1000uF 25V +/-20%
C655	YZ4300BD228E00	ELECTROLYTIC CAPACITOR 2200uF 25V +/-20%(16 X 25mm)
C654	YZ4300BD477E00	ELECTROLYTIC CAPACITOR 470uF 25V +/-20%
C649	YZ4300BE337E00	ELECTROLYTIC CAPACITOR 330uF 35V +/-20%
C600	YZ431WBI107E02	ELECTROLYTIC CAPACITOR 100UF 200V +/-20%(105 DEGREE)
C600A	YZ431WBI107E02	ELECTROLYTIC CAPACITOR 100UF 200V +/-20%(105 DEGREE)
C477	YZ4300BJ106E00	ELECTROLYTIC CAPACITOR 10UF 250V +/-20%
⚠ C601	YZ4300FW224D00	AC CAPACITOR 0.22uF AC250V-500V +/-10%
⚠ C602	YZ4300FW224D00	AC CAPACITOR 0.22uF AC250V-500V +/-10%
⚠ C629	YZ4304SX222E00	SAFETY CERAMIC CAPACITOR 0.0022UF AC250V-400V +/-20%
D603	YZ450015397000	NORMAL RECTIFIER DIODE 1N5397 1.5A/600V(DO-15)
D604	YZ450015397000	NORMAL RECTIFIER DIODE 1N5397 1.5A/600V(DO-15)
D605	YZ450015397000	NORMAL RECTIFIER DIODE 1N5397 1.5A/600V(DO-15)
D606	YZ450015397000	NORMAL RECTIFIER DIODE 1N5397 1.5A/600V(DO-15)
D643	YZ4500220102T0	HIGH SPEED RECTIFIER DIODE ER201 100V/2A(DO-15) (TAPE TYPE)
D645	YZ4500220102T0	HIGH SPEED RECTIFIER DIODE ER201 100V/2A(DO-15) (TAPE TYPE)
D641	YZ45002RG15J00	HIGH SPEED RECTIFIER DIODE RGP15J 60 0V/1.5V
D644	YZ45042RU4AM00	HIGH SPEED RECTIFIER DIODE RU4AM SANKEN
Q451	YZ4600D2499000	TRANSISTOR 2SD2499/3DD2499 (FOR HORIZONTAL DEFLECTION)
IC702	YZ470024C08008	I.C. 8K-BIT IIC BUS SERIAL EEPROM DIP PACKAGE
⚠ IC602	YZ4701T6210J04	I.C. TLP621 TOSHIBA (PHOTO TRANSISTOR)
IC161	YZ4706D8944017	I.C.TDA8944J PHILIPS(BRIDGE TIED LOAD(BTL)AUDIO AMPLIFIER 2X7W STEREO)DBS17
IC701	YZ4706D9367064	I.C TDA9367PS-N2-5 PHILIPS FULL SYSTEM TV SIGNAL PROCESSOR-TELE.DECODER+QSS
IC121	YZ4706D9859032	I.C. TDA9859 PHILIPS (UNIVERSAL HI-FI AUDIO PROCESSOR FOR TV)
IC861	YZ4706D9874044	I.C. TDA9874A PHILIPS (DIGITAL TV SOUNDDEMODULATOR/DECODER) QFP44 PACKAGE
IC181	YZ4707L7805003	I.C. L7805CV
IC653	YZ4707L7805003	I.C. L7805CV
IC652	YZ4707L7808003	I.C. L7808CV SGS (STABILIZING)
IC401	YZ4707S9302007	I.C. STV9302A SGS (VERTICAL DEFLECTION SYSTEM W/FLABACK GENERATOR)
IC703	YZ4709KA33VT02	I.C. KA33V SAM SUNG (VT) (TAPE TYPE)
IC601	YZ4780K0765005	I.C. KA5Q0765RTH-YDTU FAIRCHILD (FAIRCHILD POWER SWITCH)
Q642	YZ4780K431Z003	I.C. KA431Z FAIRCHILD (ADJUSTABLE REGULATOR) TO-92
⚠ L602	YZ480006150500	AC LINE FILTER 15mH X 2 (LCL-28)
⚠ L601	YZ480006250000	AC LINE FILTER 25mH X 2 (LF-16-54)
X761	YZ490011205202	CRYSTAL 12.000000MHz HC-49/US CL:18PF
X861	YZ490012457600	CRYSTAL 24.576000MHz HC-49/U CL:20PF
SAW301	YZ490036263000	BG/DK SAW FILTER K6263K 38.9MHz FOR VIDEO
SAW302	YZ490049362500	B/G D/K IM/N SAW FILTER K9362M 38.9MHz FOR AUDIO
Z354	YZ490054504300	CERAMIC TRAP 4.5MHz FOR NTSC M/N
Z353	YZ490055504300	CERAMIC TRAP 5.5MHz FOR PAL BG

ELECTRICAL PARTS LIST

FOR REFERENCE ONLY

Circuit No	Part No	Description
T450	YZ510604100000	HORIZONTAL DRIVE TRANSFORMER FOR LOW VOLTAGE
A301	YZ5200389W1600	B/G WORLD STANDARD FS TUNER 5V 38.9MHz W/O AGC 4V FOR 5P60
CN601	YZ540091000002	WAFER 10mm 2.35mm TJC1-2A 2 PIN
CN602	YZ540091000002	WAFER 10mm 2.35mm TJC1-2A 2 PIN
CN803	YZ540092500004	WAFER 2.5mm H X 4 PIN
CN701	YZ540092500005	WAFER 2.5mm H X 5 PIN
CN402	YZ540095000004	WAFER 5mm TV-50P-04-V1 4 PIN
PCB	YZ5800A3P31100	MAIN P.C.BOARD 304 X 246 X 1.6mm FOR 3P31 CHASSIS
F601	YZ600135000100	FUSE T3.15A 250V W/APPROVAL MARKING HOLLYLAND
CN801	YZ610016315492	RCA JACK X 3 H-TYPE W/MOUNTING BOSS (PCB-MTG PITCH=15mm) YELLOW, WHITE, RED
CN804	YZ610016315492	RCA JACK X 3 H-TYPE W/MOUNTING BOSS (PCB-MTG PITCH=15mm) YELLOW, WHITE, RED
CN802	YZ610016315562	RCA JACK x 3 H-TYPE W/MOUNTING BOSS (PCB-MTG PITCH=15mm) GREEN,BLUE,RED
L605	YZ640003004100	FERRITE BEAD 3.5 X 1 X 9 W/JUMPER FOR 5T01
033PC3P311A0M		CRT BOARD ASSEMBLY FOR 3P31 (AUTO INSERT)
R501	YZ4100AD1010T0	CARBON FILM RESISTOR 100 OHM 1/4W +/-5% (TAPE TYPE)
R502	YZ4100AD1010T0	CARBON FILM RESISTOR 100 OHM 1/4W +/-5% (TAPE TYPE)
R503	YZ4100AD1010T0	CARBON FILM RESISTOR 100 OHM 1/4W +/-5% (TAPE TYPE)
R504	YZ4100AF1020T0	CARBON FILM RESISTOR 1K OHM 1/2W +/-5% (TAPE TYPE)
R505	YZ4100AF1020T0	CARBON FILM RESISTOR 1K OHM 1/2W +/-5% (TAPE TYPE)
R506	YZ4100AF1020T0	CARBON FILM RESISTOR 1K OHM 1/2W +/-5% (TAPE TYPE)
D501	YZ4500215700T0	HIGH SPEED RECTIFIER DIODE BA157 400V/1A(TAPE TYPE)
D502	YZ4500215700T0	HIGH SPEED RECTIFIER DIODE BA157 400V/1A(TAPE TYPE)
D503	YZ4500215700T0	HIGH SPEED RECTIFIER DIODE BA157 400V/1A(TAPE TYPE)
L501	YZ4800011000T0	PEAKING COIL 10uH +/-10% (TAPE TYPE)
W703	YZ5900G4010600	COPPER JUMPER 0.6MM DIA. L=40mm
W704	YZ5900G4010600	COPPER JUMPER 0.6MM DIA. L=40mm
W705	YZ5900G4010600	COPPER JUMPER 0.6MM DIA. L=40mm
033PC3P311H0M		CRT BOARD ASSEMBLY FOR 3P31 (MANUAL INSERT)
C503	YZ4300AT102D00	CERAMIC CAPACITOR 0.001uF 2KV +/-10%
C501	YZ4300BJ106E00	ELECTROLYTIC CAPACITOR 10UF 250V +/-20%
C502	YZ4300EJ104C00	METALLIZED POLYESTER FILM CAPACITOR 0.1uF 250V +/-5%
IC501	YZ4706D6107Q09	I.C. TDA6107Q PHILIPS (TRIPLE VIDEO OUTPUT AMPLIFIER)
CN503	YZ540090000001	WAFER 2.35mm 1 PIN
XS501	YZ610006010829	CRT SOCKET GZS10-2-108 E/E 15-18KV FOR 21"-29"
043PD1T0BP00M		CONTROL ASSEMBLY FOR 3P31
RD11	YZ4100AD1010T0	CARBON FILM RESISTOR 100 OHM 1/4W +/-5% (TAPE TYPE)
RR1	YZ4100AD1020T0	CARBON FILM RESISTOR 1K OHM 1/4W +/-5% (TAPE TYPE)
RD3	YZ4100AD1520T0	CARBON FILM RESISTOR 1.5K OHM 1/4W +/-5% (TAPE TYPE)
RD8	YZ4100AD1810T0	CARBON FILM RESISTOR 180 OHM 1/4W +/-5% (TAPE TYPE)
RD7	YZ4100AD2210T0	CARBON FILM RESISTOR 220 OHM 1/4W +/-5% (TAPE TYPE)
RD6	YZ4100AD3310T0	CARBON FILM RESISTOR 330 OHM 1/4W +/-5% (TAPE TYPE)
RD5	YZ4100AD4710T0	CARBON FILM RESISTOR 470 OHM 1/4W +/-5% (TAPE TYPE)
RD2	YZ4100AD4720T0	CARBON FILM RESISTOR 4.7K OHM 1/4W +/-5% (TAPE TYPE)
RD4	YZ4100AD8210T0	CARBON FILM RESISTOR 820 OHM 1/4W +/-5% (TAPE TYPE)
CR1	YZ4300BC106ETO	ELECTROLYTIC CAPACITOR 10UF 16V +/-20%(TAPE TYPE)
M001	YZ530214003800	INFRARED RECEIVER MODULE HS0038B 38KHz FOR PCM REMOTE CONTROL SYSTEMS
H001	YZ540142036205	90 DEGREE PIN 05+HOUSING 05(TJC3)+360mmFLAT CABLE UL2468 AWG26
SW001	YZ550011012000	TACT SWITCH VERTICAL TYPE KNOB 6mm H=12mm
SW002	YZ550011012000	TACT SWITCH VERTICAL TYPE KNOB 6mm H=12mm
SW003	YZ550011012000	TACT SWITCH VERTICAL TYPE KNOB 6mm H=12mm

ELECTRICAL PARTS LIST

FOR REFERENCE ONLY

Circuit No	Part No	Description
SW004	YZ550011012000	TACT SWITCH VERTICAL TYPE KNOB 6mm H=12mm
SW005	YZ550011012000	TACT SWITCH VERTICAL TYPE KNOB 6mm H=12mm
SW006	YZ550011012000	TACT SWITCH VERTICAL TYPE KNOB 6mm H=12mm
LED001	YZ570015012000	LED LIGHT EMISSION 3.1mm RED LONG LEAD
PCB	YZ5800D1T0BP31	CONTROL P.C.BOARD 160 X 40 X 1.6mm FOR 3P31 CHASSIS
RD9	YZ5900G4010600	COPPER JUMPER 0.6MM DIA. L=40mm
R711	YZ4100AD1010T0	CARBON FILM RESISTOR 100 OHM 1/4W +/-5% (TAPE TYPE)
R712	YZ4100AD1010T0	CARBON FILM RESISTOR 100 OHM 1/4W +/-5% (TAPE TYPE)
C713	YZ4300AF103HT0	CERAMIC CAPACITOR 0.01uF 50V +80-20% (TAPE TYPE)
C714	YZ4300AF103HT0	CERAMIC CAPACITOR 0.01uF 50V +80-20% (TAPE TYPE)
C711	YZ4300BB107E00	ELECTROLYTIC CAPACITOR 100UF 10V +/-20% (6.3 X 5mm)
C712	YZ4300BB107E00	ELECTROLYTIC CAPACITOR 100UF 10V +/-20% (6.3 X 5mm)
CN712	YZ540020780204	HOUSING 04 + 800mm X 2=BLACK 200mm X 2 RED WHITE UL1007AWG22
CN711	YZ540042020205	90 DEGREE PIN 05 + HOUSING 05 + 200mm FLAT CABLE UL2468 AWG24
CN701	YZ540142350204	90 DEGREE PIN 04 + HOUSING 04 (TJC3) + 500mm SHIELD WIRE UL2547 AWG24
PCB	YZ5800G1T0BP31	FRONT AV IN P.C.BOARD 100 X 30 X 1.6mm FOR 3P31 CHASSIS
J711	YZ5900G4010600	COPPER JUMPER 0.6MM DIA. L=40mm
CN713	YZ610002350801	EARPHONG JACK 3.6mm STEREO FOR 3T05
P703	YZ610016195121	RCA JACK H=19.5mm RED VERTICAL TYPE 3 PINS W/SW
P701	YZ610016195141	RCA JACK H=19.5mm YELLOW VERTICAL TYPE 3PINS W/SW
P702	YZ610016195191	RCA JACK H=19.5mm WHITE VERTICAL TYPE 3PINS W/SW
073PG3P31100M		FRONT AV IN ASSEMBLY RCA JACK/YC FOR 3P31 (MANUAL INSERT)
CN703	YZ540142014203	90 DEGREE PIN 03 + HOUSING 03 (TJC3) + 140mm FLAT CABLE UL2468 AWG24
CN702	YZ540142028203	90 DEGREE PIN 03 + HOUSING 03 (TJC3) + 280mm FLAT CABLE UL2468 AWG24
PCB	YZ5800G3P31100	AV I/O P.C.BOARD 64 X 30 X 1.6mm FOR 3P31
P701	YZ610016107021	RCA JACK H=17mm RED VERTICAL TYPE
P702	YZ610016107091	RCA JACK H=17mm WHITE VERTICAL TYPE
SVIDE	YZ610017005000	Y/C SOCKET FOR 25"-29"
2021T3P31200M		TABLE ASS/Y FOR 21" LG A51QDJ279 X 31
R462	YZ4100AB4720T0	CARBON FILM RESISTOR 4.7K OHM 1/16-1/6W +/-5% (TAPE TYPE)
R407	YZ4100DG271001	METAL OXIDE FILM RESISTOR 270 OHM 1W +/-5%
R480	YZ4100DH033001	METAL OXIDE FILM RESISTOR 3.3 OHM 2W +/-5%
TH601	YZ4135KZ090002	P.T.C. THERMISTOR RESISTOR 9 OHM FOR 29"-34" PANASONIC PURE FLAT CRT
C607	YZ4300BL227E00	ELECTROLYTIC CAPACITOR 220uF 400V +/-20%
C455A	YZ4300ET102C00	METALLIZED POLYPROPYLENE FILM CAPACITOR 0.001uF 2KV +/-5%
C455	YZ4300ET822C00	METALLIZED POLYPROPYLENE FILM CAPACITOR 0.0082uF 2KV +/-5%
C601	YZ4300FW224D00	AC CAPACITOR 0.22uF AC250V-500V +/-10%
C602	YZ4300FW224D00	AC CAPACITOR 0.22uF AC250V-500V +/-10%
Q451	YZ4600D2499000	TRANSISTOR 2SD2499/3DD2499 (FOR HORIZONTAL DEFLECTION)
L451	YZ480004440213	LINEAR COIL 44uH 13mm W/BACKET FOR 14"-21" TV (SHORT LEAD PITCH=5mm)
H602	YZ480008230002	DEGAUSSING COIL FOR 21" TV L=2300mm
CRT	YZ500951000B01	21" LG.PHILIPS COLOR PICTURE TUBE A51QDJ279 X 31 (NORTH) DIA.29.1mm
T451	YZ510105110104	21" FLYBACK TRANSFORMER(MULTI-LAYER) B+110V JF0501-3227
T450	YZ510604100000	HORIZONTAL DRIVE TRANSFORMER FOR LOW VOLTAGE
T601	YZ511506400103	SWITCHING TRANSFORMER BCK4001-122A FOR 3P31
H603	YZ540021511301	HOUSING 01 + 380mm 1015#20 WIRE + 1060mm KNITTING COPPER WIRE (FOR 21" TV)
H501	YZ540025040205	HOUSING 05 + 400mm WIRE X 4 1=RED 3=BLUE 4=YELLOW 5=GREEN UL1015 AWG22
L453	YZ5900G4010600	COPPER JUMPER 0.6MM DIA. L=40mm
273P1T0BST00M		NON COMMON PARTS FOR 3P31
H601B	YZ540027025203	HOUSING 03(7.92mm)+250mmx2,1=RED,2=NIL,3=BLACK,UL1007 AWG18



ELECTRICAL PARTS LIST

FOR REFERENCE ONLY

Circuit No	Part No	Description
H502	YZ540102040205	PIN 05 + HOUSING 05 (TJC3) + 400mm FLATCABLE UL2468 AWG24
H501	YZ540102042204	PIN 04 + HOUSING 04 (TJC3) + 420mm FLATCABLE UL2468 AWG24 W/UL TUBE
⚠ SW601A	YZ550002021100	MAIN POWER SWITCH KDC-A11 W/SCREW HOLE
SPL	YZ560010808401	SPEAKER 8 OHM 8W 57 X 125mm FOR 2588
SPR	YZ560010808401	SPEAKER 8 OHM 8W 57 X 125mm FOR 2588
W011	YZ5900G4010600	COPPER JUMPER 0.6MM DIA. L=40mm
W012	YZ5900G4010600	COPPER JUMPER 0.6MM DIA. L=40mm
⚠ H601	YZ5926A2830001	AC Power Cord (CEE Plug for 081,433,193, etc)
⚠ H601	YZ5926A2830002	AC Power Cord (BS Plug for Code 051,201,191 only)
⚠ H601	YZ5926A2830602	AC Power Cord (Australia Plug for Code 751 only)

MECHANICAL PARTS LIST

FOR REFERENCE ONLY

Part No	Qty	Description
YZ030121T0C001	1	POLYFOAM END CAP.R&L (TOP&BOTTOM) SMALL
YZ040400005400	1	POLYBAG W100 X H95cm
YZ040409014003	1	POLYBAG 9" X 14" X 0.04 MM (PO) W/PE
YZ041505506510	1	BUBBLE BAG 5.5" X 6.5"
YZ060220021800	3	QC PASSED LABEL (WHITE)
YZ060220121800	1	QC PASSED LABEL (GOLD)
YZ100221T07101	1	BACK CABINET DARK GREY #DG001 94V-0
YZ100721T0C001	1	FRONT LENS - TRANSPARENT (PC)
YZ100821T0C001	1	CONTROL KEYS KNOB - #TS003
YZ100921T0C001	1	POWER KNOB - #TS003
YZ101929F10002	3	WIRE HOLDER DIA. 15 MM
YZ103929F10002	2	HANDLE PLATE
YZ120521T04001	1	INLAY - RCA JACK X 12 STEREO(3P31)
YZ130521T0B001	4	TAPE 33 X 20 X 0.15mm
YZ130621600004	3	TAPE LABEL 350 X 25 X 1 MM
YZ131229TK0001	4	RUBBER PAD
YZ132029F10001	2	ADHESIVED TAPE CUSHION 105 X 50 X 1 MM
YZ150202829900	4	CRT MTG. BRACKET
YZ152382180001	8	STAPLE (SILVER)
YZ190100821610	1	POWER KNOB SPRING - DIA. 0.6 SPRING WIRE
YZ190200015010	2	GROUNDING WIRE SPRING- FOR KNITTING WIRE
YZ240100040000	11	CABLE TIE - L = 4"
YZ240100080001	4	CABLE TIE - L = 8" W = 2.5MM
YZ26BA030080N0	10	BA 3 X 8
YZ26BA030100N0	2	BA 3 X 10
YZ26BA035120N0	4	BA 3.5 X 12
YZ26BA035160B0	3	BA 3.5 X 16 (BLACK)
YZ26BA040120B0	1	BA 4 X 12 (BLACK)
YZ26BA040200B0	6	BA 4 X 20 (BLACK)
YZ26BA040200N0	12	BA 4 X 20
YZ26KA026080B0	3	KA 2.6 X 8 (BLACK)
YZ27MHM60A0N05	4	M6 NUT
YZ2801030810F0	1	FIBRE WASHER - DIA. 3 X 8 X 1 MM
YZ2801031412F0	4	FIBRE WASHER - DIA. 3 X 14 X 1.2 MM
YZ2801062220R0	4	RUBBER WASHER - DIA. 6 X 22 X 2 MM
YZ2801062230R0	4	RUBBER WASHER - DIA. 6 X 22 X 3 MM
YZ380105000000	60	HEAT-SHRINKABLE TUBE - DIA. 5.0MM
YZ380306000000	10	PVC TUBE - DIA. 6.0MM
YZ101321NS0002	1	ANTENNA HOLDER - DARK GREY #DG001
YZ26BA030100N0	1	BA 3 X 10
YZ100121T0C102	1	FRONT CABINET - #TS003/#NB001 3P31 94V-0
YZ010021T0C000	1	CARTON BOX NO PAINTING SMALL

MECHANICAL PARTS LIST

FOR REFERENCE ONLY

Part No	Qty	Description
YZ090205033701	1	NAME PLATE - ALUMINIUM "HITACHI" BLACK 7
YZ121321T0C001	1	INLAY - SIDE AV #DG001 AVIN2 (V-L-R-@)
YZ0801UM4AAA07	2	BATTERY UM-4AAA (DESAY)
YZ0801UM4AAA10	2	BATTERY UM-4AAA (EAST POWER)
YZ100521T04201	1	BACK AV BRACKET-(94V-0)W/O POWER LINE
YZ101850021800	2	INSULATOR RING - DIA. 4.1 MM
YZ101940021800	2	WIRE HOLDER
YZ240100040000	10	CABLE TIE - L = 4"
YZ240100080001	4	CABLE TIE - L = 8" W = 2.5MM
YZ240200040000	1	COLOUR TIE - L = 100 MM
YZ150582080002	2	HEAT SINK (36A)
YZ26BM030080N0	2	BM 3 X 8
YZ27MHM3050N03	2	M3 NUT
YZ2802030508M2	2	M3 SPRING WASHER
YZ15053P310006	1	HEAT SINK (M20)
YZ26BM030100N0	2	BM 3 X 10
YZ27MHM3050N03	2	M3 NUT
YZ2802030508M2	2	M3 SPRING WASHER
YZ100521T04101	1	BACK AV BRACKET - BLACK (HIPS) 94V-0
YZ26BA030100N0	2	BA 3 X 10
YZ2801030810F0	1	FIBRE WASHER - DIA. 3 X 8 X 1 MM
YZ15053P310004	1	HEAT SINK (M22)
YZ26BM030100N0	2	BM 3 X 10
YZ27MHM3050N03	2	M3 NUT
YZ2802030508M2	2	M3 SPRING WASHER
YZ15053P310005	1	HEAT SINK (M21)
YZ2802030508M2	1	M3 SPRING WASHER
YZ290101603200	28	EYELET 1.6 X 3.2 MM
YZ290102003000	2	EYELET 2 X 3 MM
YZ290102303500	17	EYELET 2.3 X 3.5 MM
YZ15053P310001	1	HEAT SINK (M19)
YZ26BM030100N0	1	BM 3 X 10
YZ27MHM3050N03	1	M3 NUT
YZ2802030508M2	1	M3 SPRING WASHER

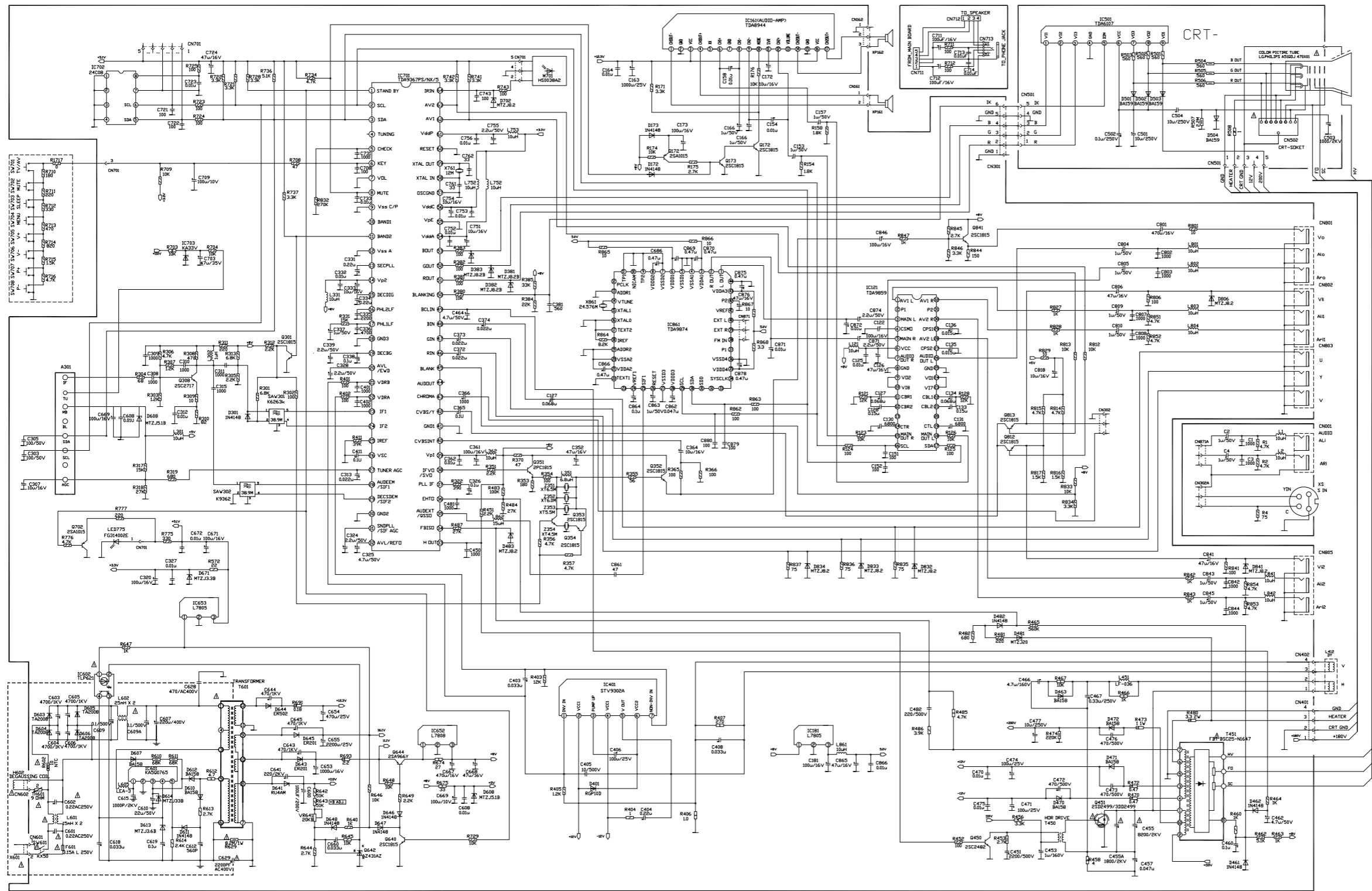

C21-F880SNT SCHEMATIC DIAGRAM

- NOTE:
- (1) ALL RESISTERS ARE IN OHM, ALL COILS ARE IN HZ; ALL THE CRYSTALS ARE IN HZ;
 - (2) THE AREA ENCLOSED BY IS LIVE AREA AND DIRECTLY CONNECTED TO MAIN VOLTAGE.
 - (3) THE DEVICE WITH Δ ARE SAFETY CRITICAL DEVICES;
 - (4) THE DEVICE WITH * ARE SUBJECT TO CHANGE OR OMIT ACCORDING TO DIFFERNT TV SETS;
 - (5) THE AREA ENCLOSED BY - - - IS OPTIONAL;
 - (6) THE CIRCUIT IS SUBJECT TO CHANGE WITHOUT NOTICE!
 - (7) All components with sign Δ is FDA critical components.

TITLE:	3P31 SCHEMATIC DIAGRAM	
P/N:	0502-A3P311-00	
SYSTEM:	PAL/SECAM/NTSC BG/DK/I/M NICAM/TELEXT YUV/S-VIDEO/AV-IN/OUT	
SOFT::	Philips	
ISSUED BY:	yangtr	DATA: 2005-11-05
CHECKED BY:	yangtr	DATA: 2005-11-05
APPROVED BY:	hansx	DATA: 2005-11-05
REV DATA:	2005-11-05	

HITACHI

Inspire the Next

C21-F880S/SN/SNT

SC No.0016E

Copyright © Digital Media Systems Group, (2006) All rights reserved