

12.2. Schematic Diagram (Base Unit)

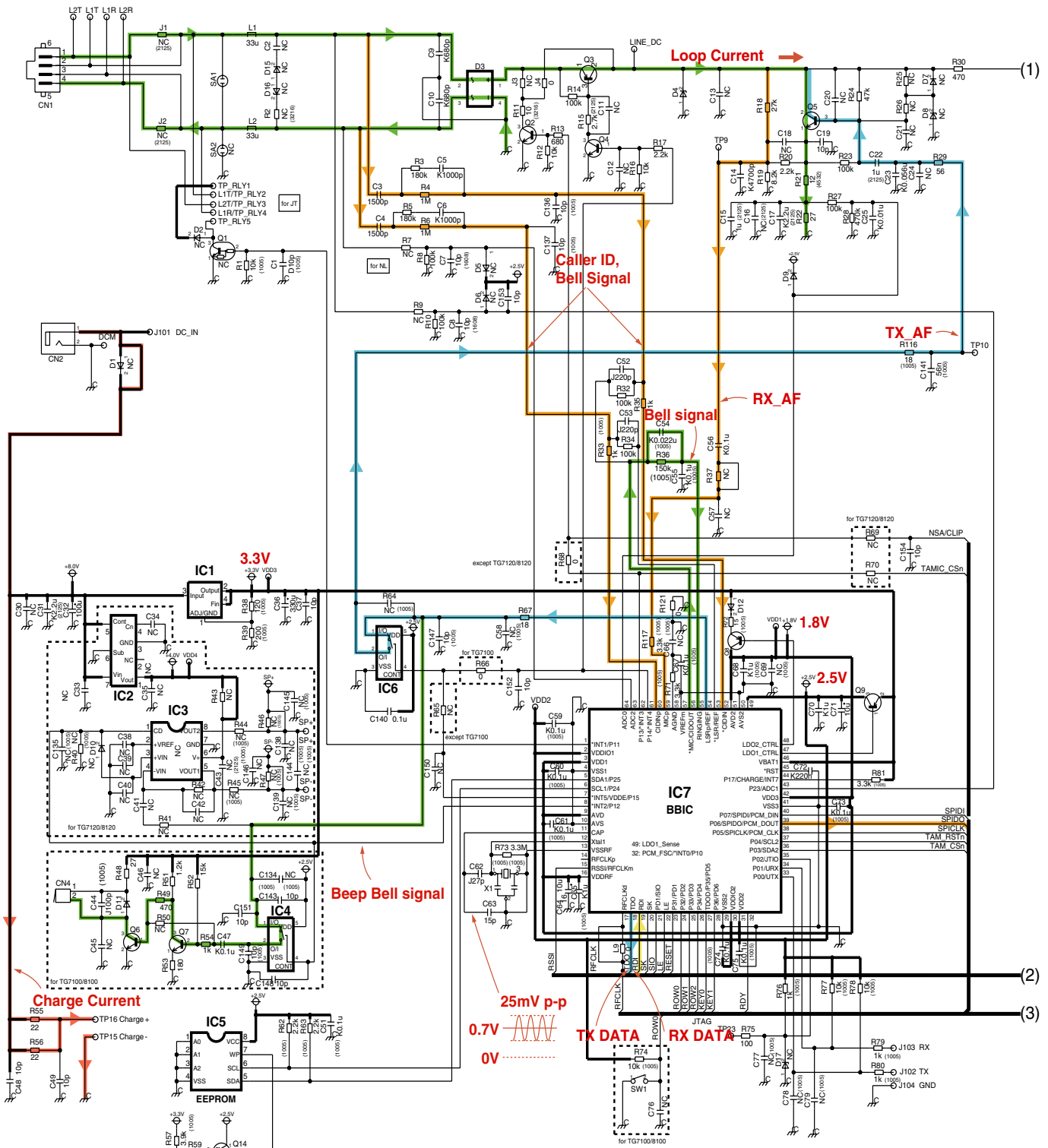

NC: No Components

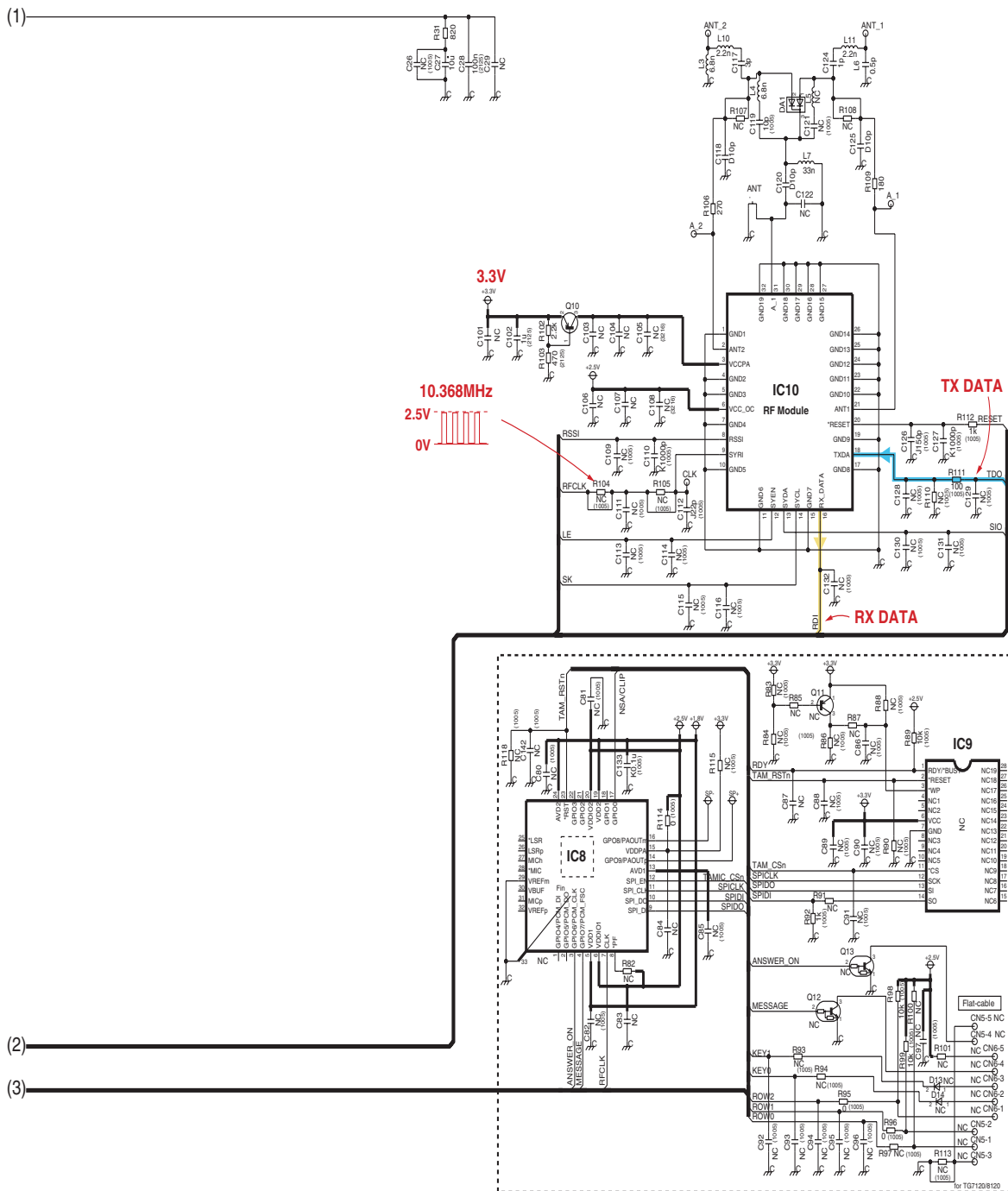

NC: No Components

KX-TG7105/7106RU SCHEMATIC DIAGRAM (Base Unit)

