

Service Manual

Telephone Equipment

KX-TG7100ES

KX-TG7102ES

KX-TG7103ES

KX-TGA710ES

Digital Cordless Phone

Silver Version
(for United Kingdom)

Caller ID Compatible



KX-TGA710ES
(HANDSET)

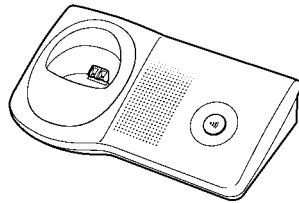

KX-TG7100ES
(BASE UNIT)

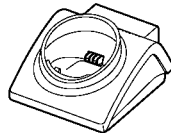

(CHARGER UNIT)

Configuration for each model

Model No	Base Unit	Handset	Charger Unit
KX-TG7100	1 (TG7100)	1 (TGA710)	
KX-TG7102	1 (TG7100)	2 (TGA710)	1
KX-TG7103	1 (TG7100)	3 (TGA710)	2

Panasonic

© 2006 Panasonic Communications Co., Ltd. All rights reserved. Unauthorized copying and distribution is a violation of law.

 **WARNING**

This service information is designed for experienced repair technicians only and is not designed for use by the general public. It does not contain warnings or cautions to advise non-technical individuals of potential dangers in attempting to service a product. Products powered by electricity should be serviced or repaired only by experienced professional technicians. Any attempt to service or repair the product or products dealt with in this service information by anyone else could result in serious injury or death.

IMPORTANT SAFETY NOTICE

There are special components used in this equipment which are important for safety. These parts are marked by  in the Schematic Diagrams, Circuit Board Diagrams, Exploded Views and Replacement Parts List. It is essential that these critical parts should be replaced with manufacturer's specified parts to prevent shock, fire or other hazards. Do not modify the original design without permission of manufacturer.

IMPORTANT INFORMATION ABOUT LEAD FREE, (PbF), SOLDERING

If lead free solder was used in the manufacture of this product the printed circuit boards will be marked PbF. Standard leaded, (Pb), solder can be used as usual on boards without the PbF mark. When this mark does appear, please read and follow the special instructions described in this manual on the use of PbF and how it might be permissible to use Pb solder during service and repair work.

- When you note the serial number, write down all 11 digits. The serial number may be found on the bottom of the unit.
- The illustrations in this Service Manual may vary slightly from the actual product.

Note for TABLE OF CONTENTS:

Because TABLE OF CONTENTS 5, 6 and 7 are the extract from the Operating Instructions of this model, it is subject to change without notice. You can download and refer to the original Operating Instructions on TSN Server for further information.

TABLE OF CONTENTS

	PAGE		PAGE
1 Safety Precaution	4	14.3. Terminal Guide of the ICs, Transistors and Diodes	72
1.1. For Service Technicians	4	15 Exploded View and Replacement Parts List	73
2 Warning	4	15.1. Cabinet and Electric Parts (Base Unit)	73
2.1. Battery Caution	4	15.2. Cabinet and Electric Parts (Handset)	74
2.2. About Lead Free Solder (Pbf: Pb free)	4	15.3. Cabinet and Electric Parts (Charger Unit)	75
3 Specifications	6	15.4. Accessories and Packing Materials	76
4 Technical Descriptions	7	15.5. Replacement Part List	79
4.1. Block Diagram (Base Unit)	7		
4.2. Circuit Operation (Base Unit)	8		
4.3. Block Diagram (Handset)	11		
4.4. Circuit Operation (Handset)	12		
4.5. Circuit Operation (Charger Unit)	13		
4.6. Signal Route	14		
5 Location of Controls and Components	15		
5.1. Controls	15		
6 Installation Instructions	15		
6.1. Connections	15		
6.2. Battery	16		
7 Operation Instructions	17		
7.1. Base Unit Settings	17		
7.2. Handset Settings	18		
7.3. Registering a Handset to the Base Unit	19		
7.4. For Service Hint	20		
8 Service Mode	21		
8.1. Engineering Mode	21		
9 Troubleshooting Guide	25		
9.1. Troubleshooting Flowchart	25		
9.2. Troubleshooting by Symptom (Base Unit and Charger Unit)	34		
9.3. Troubleshooting by Symptom (Handset)	38		
9.4. How to Replace the Flat Package IC	41		
10 Disassembly and Assembly Instructions	43		
10.1. Disassembly Instructions	43		
10.2. How to Replace the Handset LCD	46		
11 Measurements and Adjustments	47		
11.1. The Setting Method of JIG (Base Unit)	47		
11.2. Adjustment Standard (Base Unit)	49		
11.3. Adjustment Standard (Charger Unit)	50		
11.4. The Setting Method of JIG (Handset)	51		
11.5. Adjustment Standard (Handset)	53		
11.6. Things to Do after Replacing IC	54		
11.7. RF Specification	55		
11.8. How to Check the Handset Speaker of Receiver	56		
11.9. Frequency Table (MHz)	56		
12 Schematic Diagram	57		
12.1. For Schematic Diagram	57		
12.2. Schematic Diagram (Base Unit)	58		
12.3. Schematic Diagram (Handset)	60		
12.4. Schematic Diagram (Charger Unit)	62		
13 Printed Circuit Board	63		
13.1. Circuit Board (Base Unit)	63		
13.2. Circuit Board (Handset)	65		
13.3. Circuit Board (Charger Unit)	67		
14 Appendix Information of Schematic Diagram	68		
14.1. CPU Data (Base Unit)	68		
14.2. CPU Data (Handset)	70		

1 Safety Precaution

1.1. For Service Technicians

ICs and LSIs are vulnerable to static electricity.

When repairing, the following precautions will help prevent recurring malfunctions.

1. Cover the plastic parts boxes with aluminum foil and ground them.
2. Ground the soldering irons.
3. Use a conductive mat on the worktable.
4. Do not touch IC or LSI pins with bare fingers.

2 Warning

2.1. Battery Caution

1. Danger of explosion if battery is incorrectly replaced.
2. Replace only with the same or equivalent type recommended by the manufacturer.
3. Dispose of used batteries according to the manufacture's Instructions.

2.2. About Lead Free Solder (PbF: Pb free)

Note:

In the information below, Pb, the symbol for lead in the periodic table of elements, will refer to standard solder or solder that contains lead.

We will use PbF solder when discussing the lead free solder used in our manufacturing process which is made from Tin (Sn), Silver (Ag), and Copper (Cu).

This model, and others like it, manufactured using lead free solder will have PbF stamped on the PCB. For service and repair work we suggest using the same type of solder.

Caution

- PbF solder has a melting point that is 50 °F ~ 70 °F (30 °C ~ 40 °C) higher than Pb solder. Please use a soldering iron with temperature control and adjust it to 700 °F ± 20 °F (370 °C ± 10 °C).
- Exercise care while using higher temperature soldering irons.:
Do not heat the PCB for too long time in order to prevent solder splash or damage to the PCB.
- PbF solder will tend to splash if it is heated much higher than its melting point, approximately 1100 °F (600 °C).
- When applying PbF solder to double layered boards, please check the component side for excess which may flow onto the opposite side (See the figure below).

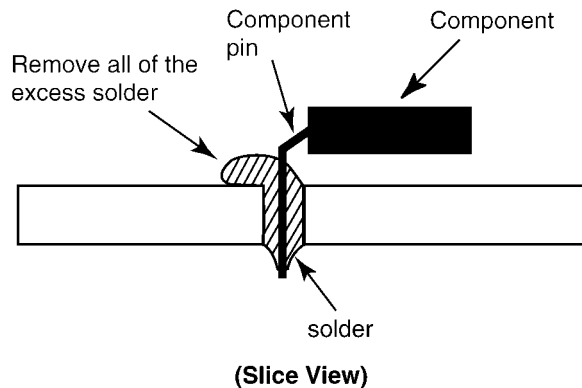

2.2.1. Suggested PbF Solder

There are several types of PbF solder available commercially. While this product is manufactured using Tin, Silver, and Copper (Sn+Ag+Cu), you can also use Tin and Copper (Sn+Cu) or Tin, Zinc, and Bismuth (Sn+Zn+Bi). Please check the manufacturer's specific instructions for the melting points of their products and any precautions for using their product with other materials.

The following lead free (PbF) solder wire sizes are recommended for service of this product: 0.3 mm, 0.6 mm and 1.0 mm.

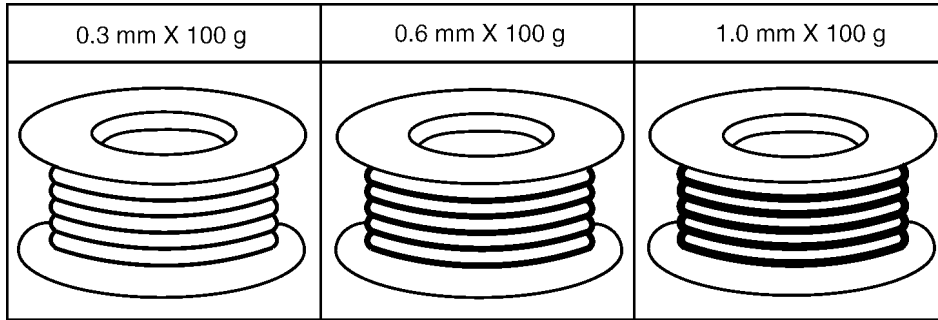

2.2.2. How to Recognize that Pb Free Solder is Used

(Example: Handset P.C.B.)

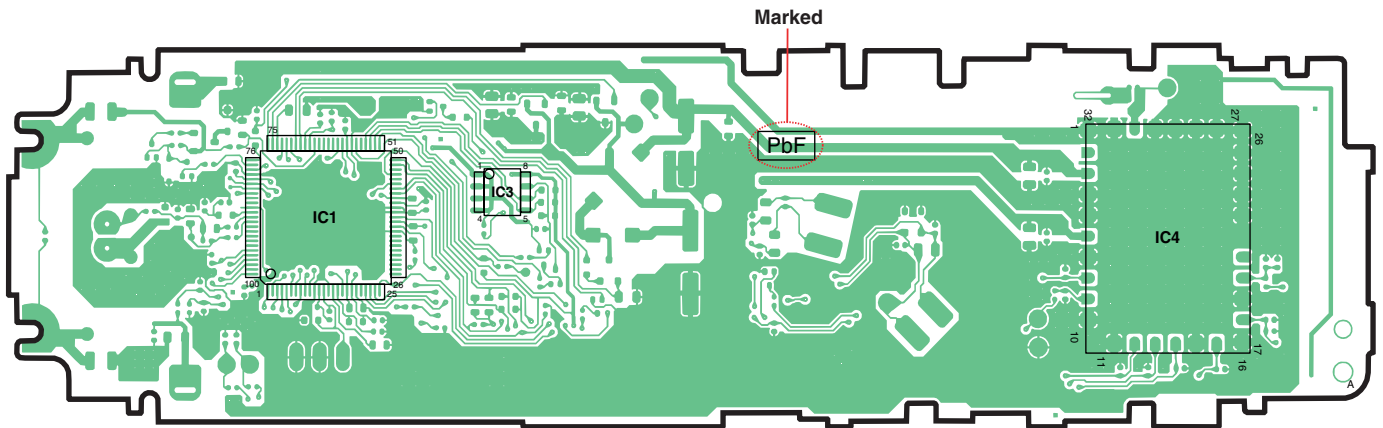

(Component View)

Note:

The location of the "PbF" mark is subject to change without notice.

3 Specifications

■ Standard:

DECT (Digital Enhanced Cordless Telecommunications),
GAP (Generic Access Profile)

■ Number of channels:

120 Duplex Channels

■ Frequency range:

1.88 GHz to 1.9 GHz

■ Duplex procedure:

TDMA (Time Division Multiple Access)

■ Channel spacing:

1,728 kHz

■ Bit rate:

1,152 kbit/s

■ Modulation:

GFSK (Gaussian Frequency Shift Keying)

■ RF transmission power:

Approx. 250 mW

■ Power source (AC Adaptor):

220–240 V, 50 Hz

Base unit: PQLV207EZ

Charger: PQLV209EZ

■ Power consumption

Base unit:

Standby: Approx. 1.9 W

Maximum: Approx. 6.8 W

Charger:

Standby: Approx. 1.5 W

Maximum: Approx. 3 W

■ Operating conditions:

5 °C–40 °C, 20 %–80 % relative air humidity (dry)

■ Dimensions:

Base unit: Approx. 60mm x 173mm x 105mm

Handset: Approx. 155mm x 48mm x 34mm

Charger: Approx. 61mm x 87mm x 95mm

■ Mass (weight):

Base unit: Approx. 220 g

Handset: Approx. 140 g

Charger: Approx. 90 g

Note:

- Specifications are subject to change.

Note for Service:

- Operation range: Up to 300 m outdoors, Up to 50 m indoors
- Analog telephone connection: Telephone Line

4.2. Circuit Operation (Base Unit)

4.2.1. Outline

Base Unit consists of the following ICs as shown in **Block Diagram (Base Unit)** (P.7).

- DECT BBIC (**B**ase **B**and IC): IC7
 - Handling all the audio, signal and data processing needed in a DECT base unit
 - Controlling the DECT specific physical layer and radio section (**B**urst **M**odule **C**ontroller section)
 - ADPCM code filter for speech encoding and speech decoding (DSP section)
 - Echo-cancellation and Echo-suppression (DSP section)
 - Any tones (tone, sidetone, ringing tone, etc.) generation (DSP section)
 - DTMF receiver (DSP section)
 - Clock Generation for RF Module
 - ADC, DAC, timer, and power control circuitry
 - All interfaces (ex: RF module, EEPROM, LED, Analog Front End, etc.)
- RF Module: IC10
 - PLL Oscillator
 - Detector
 - Compress/Expander
 - First Mixer
 - Amplifier for transmission and reception
- EEPROM: IC5
 - Temporary operating parameters (for RF, etc.)
- Additionally,
 - Power Supply Circuit (+3.3 V, +2.5 V, +1.8 V output)
 - Crystal Circuit (10.368 MHz)
 - Charge Circuit
 - Telephone Line Interface Circuit

4.2.2. Power Supply Circuit

The power is supplied to the DECT BBIC, RF Module, EEPROM and Charge Contact from AC Adaptor (+6.5 V) as shown in Fig.101. The power supply is as follows;

- DECT BBIC (IC7):
CN2 (+6.5 V) → IC1 → Q9 → IC7
CN2 (+6.5 V) → IC1 → Q8 → IC7
- RF Module (IC10):
CN2 (+6.5 V) → IC1 → Q9 → IC10 (PLL)
CN2 (+6.5 V) → IC1 → Q10 → IC10 (Power AMP)
- EEPROM (IC5):
CN2 (+6.5 V) → IC1 → Q9 → IC5
- Charge Contact (TP16):
CN2 (+6.5 V) → R55, R56 → TP16

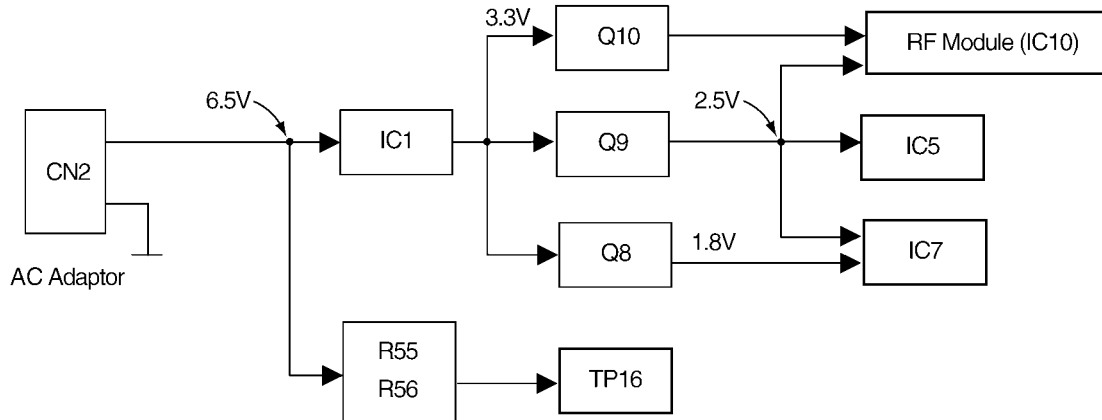

<Fig.101>

4.2.3. Telephone Line Interface

<Function>

- Bell signal detection
- Clip signal detection
- ON/OFF hook circuit

Bell & Clip (: Calling Line Identification Presentation: Caller ID) signal detection:

In the standby mode, Q3 is open to cut the DC loop current and decrease the ring load.

When ring voltage appears at the L1T (A) and L1R (B) leads (when the telephone rings), the AC ring voltage is transferred as follows;

- A → C4 → R6 → R33 → IC7 Pin 60 (CID INp)
- B → C3 → R4 → R35 → IC7 Pin 52 (CID INn)

ON/OFF hook circuit:

In the standby mode, Q3 is open, and connected as to cut the DC loop current and to cut the voice signal. The unit is consequently in an **on-hook condition**.

When IC7 detects a ring signal or press the TALK Key onto the handset, Q4 turns on and then Q3 turns on, thus providing an **off-hook condition** (DC current flows through the circuit) and the following signal flow makes the loop current.

- A → D3 → Q3 → Q5 → R21 → R22 → D3 → B [OFF HOOK]

4.2.4. Transmitter/Receiver

- Audio Circuits and DTMF tone signal circuits.

Base Unit and Handset mainly consist of RF Module and DECT BBIC.

Base Unit and Handset transmit/receive voice signal and data signal through the antenna on carrier frequency.

Signal Path:

*Refer to **Signal Route** (P.14).

4.2.4.1. Transmitter Block

The voice signal input from the TEL LINE interface goes to RF Module (IC10) through DECT BBIC (IC7) as shown in **Block Diagram (Base Unit)** (P.7)

The voice signal passes through the analog part of IC7 where it is amplified and converted to a digital audio stream signal. The burst switch controller processes this stream performing encryption and scrambling, adding the various other fields to produce the GAP (**Generic Access Profile**) standard DECT frame, assigning to a time slot and channel etc.

In IC10, the carrier frequency is changing, and frequency modulated RF signal is generated and amplified, and radiated from antenna. Handset detects the voice signal or data signal in the circuit same as the following explanation of Receiver Block.

4.2.4.2. Receiver Block

The signal of 1900 MHz band (1881.792 MHz ~ 1897.344 MHz) which is input from antenna is input to IC10 as shown in **Block Diagram (Base Unit)** (P.7).

In IC10, the signal of 1900 MHz band is downconverted to 864 kHz signal and demodulated, and goes to IC7 as GAP (**Generic Access Profile**) standard DECT frames. It passes through the decoding section burst switch controller where it separates out the frame information and performs de-encryption and de-scrambling as required. It then goes to the DSP section where it is turned back into analog audio. This is amplified by the analog front end, and goes to the TEL LINE Interface.

4.3. Block Diagram (Handset)

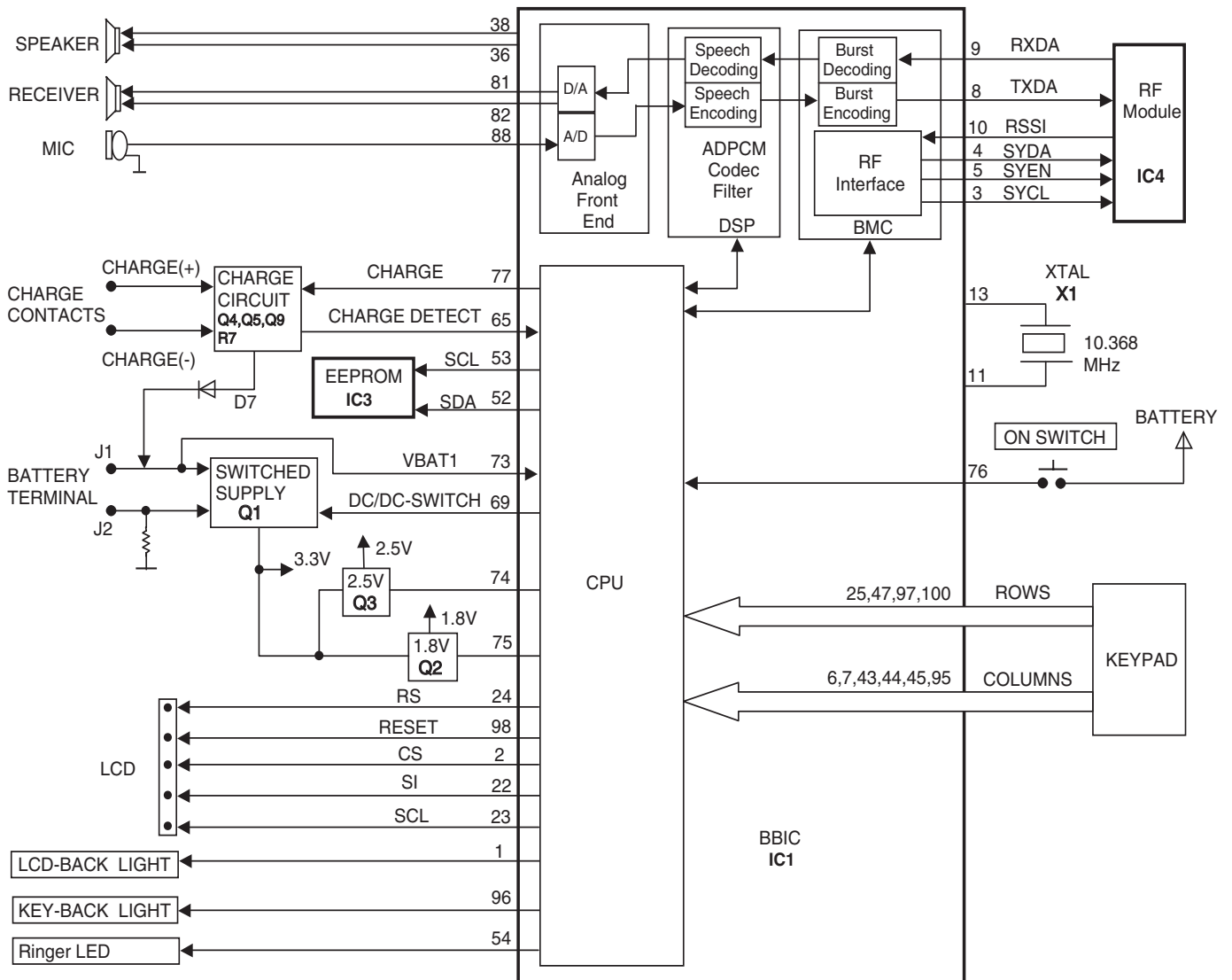

KX-TGA710 BLOCK DIAGRAM (HANDSET)

4.4. Circuit Operation (Handset)

4.4.1. Outline

Handset consists of the following ICs as shown in **Block Diagram (Handset)** (P.11).

- DECT BBIC (**B**ase **B**and IC): IC1
 - All data signals (forming/analyzing ACK or CMD signal)
 - All interfaces (ex: Key, Detector Circuit, Charge, DC/DC Converter, EEPROM, LCD)
- RF Module: IC4
 - PLL Oscillator
 - Detector
 - Compress/Expander
 - Amplifier for transmission and reception
- EEPROM: IC3
 - Temporary operating parameters (for RF, etc.)

4.4.2. Power Supply Circuit/Reset Circuit

Circuit Operation:

When power on the Handset, the voltage is as follows;

BATTERY(2.2 V ~ 2.6 V: J1) → F1, L1, D1 → Q2 (1.8 V), Q3 (2.5 V), Q1 (3.3 V)

The Reset signal generates IC1 (66 pin) and 1.8 V.

4.4.3. Charge Circuit

Circuit Operation:

When charging the handset on the Base Unit, the charge current is as follows;

DC+(6.5 V) → R55, R56 → CHARGE+(Base) → CHARGE+(Handset) → L4 → Q4 → D7 → F1 → BATTERY+... Battery...

BATTERY- → R45 → GND → L5 → CHARGE-(Handset) → CHARGE-(Base) → GND → DC-(GND)

In this way, the BBIC on Handset detects the fact that the battery is charged.

The charge current is controlled by switching Q5 of Handset.

Refer to Fig.101 in **Power Supply Circuit** (P.9).

4.4.4. Battery Low/Power Down Detector

Circuit Operation:

"Battery Low" and "Power Down" are detected by BBIC which check the voltage from battery.

The detected voltage is as follows;

- Battery Low

Battery voltage: $V(\text{Batt}) \cong 2.25 \text{ V} \pm 50 \text{ mV}$

The BBIC detects this level and "☐" starts flashing.

- Power Down

Battery voltage: $V(\text{Batt}) \cong 2.0 \text{ V} \pm 50 \text{ mV}$

The BBIC detects this level and power down.

4.4.5. Speakerphone

The hands-free loudspeaker at SP+ and SP- is used to generate the ring alarm.

4.5. Circuit Operation (Charger Unit)

4.5.1. Power Supply Circuit

The power supply is as shown.

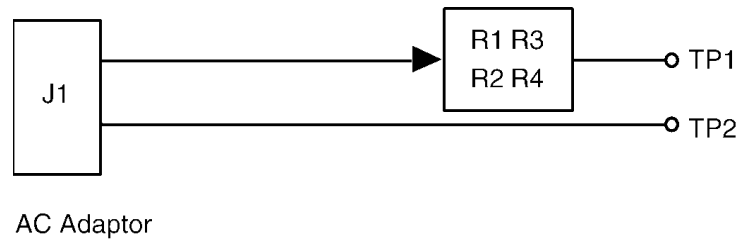

4.6. Signal Route

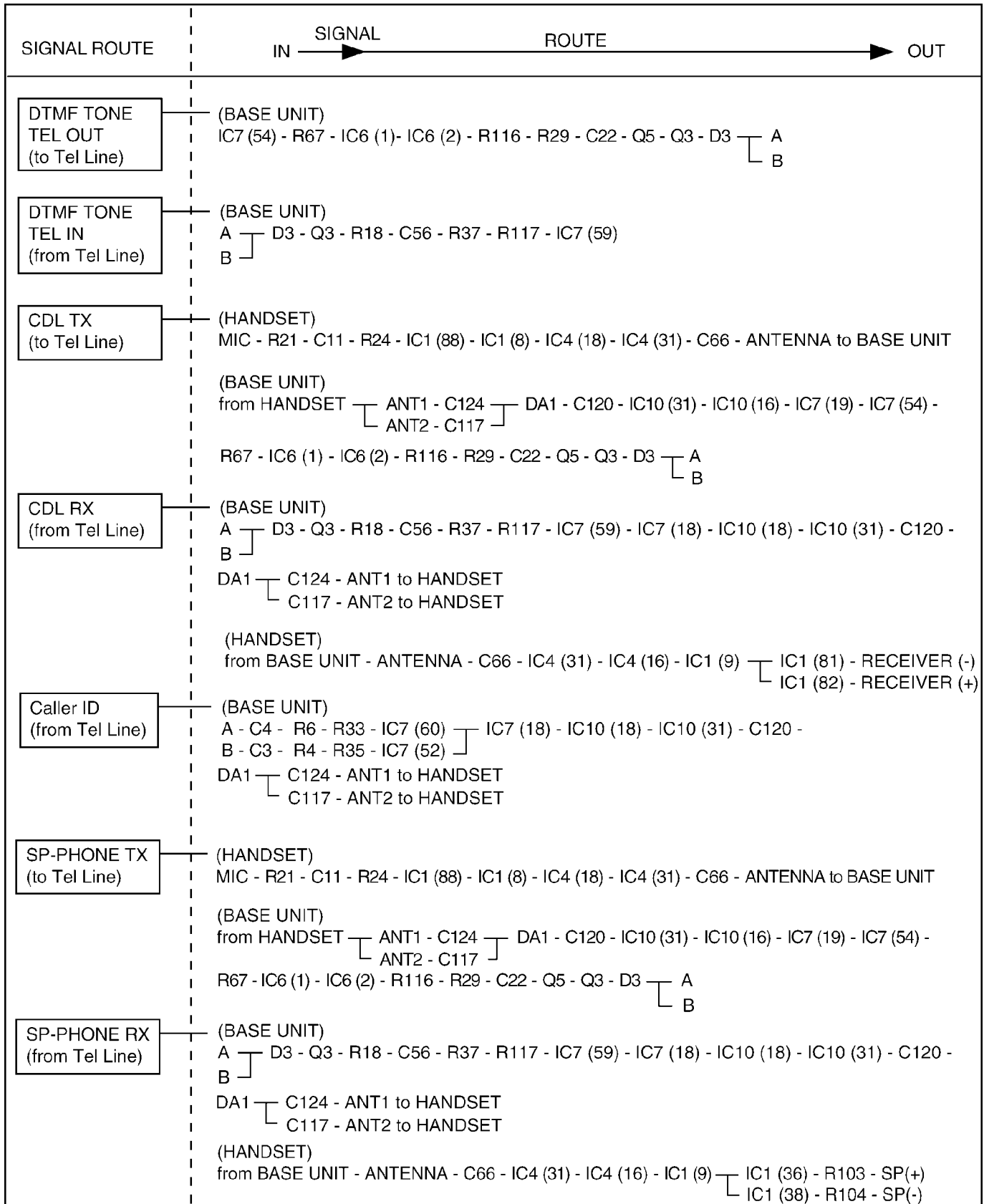

5 Location of Controls and Components

5.1. Controls

5.1.1. Base Unit

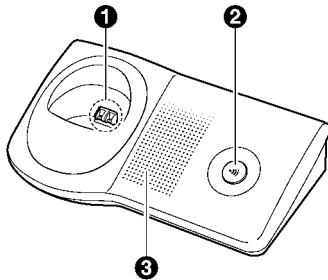

- ❶ Charge contact
- ❷ [•••] (Page)
- ❸ Ringer

5.1.2. Handset

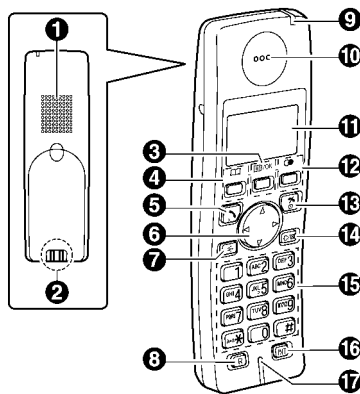

- ❶ Speaker
- ❷ Charge contact
- ❸ [≡/OK] (Menu/OK)
- ❹ [☰] (Phonebook)
- ❺ [↶] (Talk)
- ❻ Navigator key ([▲]/[▼]/[▶]/[◀])
- ❼ [☎] (Speakerphone)
- ❽ [R] (Recall)
- ❾ Charge indicator/Ringer indicator
- ❿ Receiver
- ⓫ Display
- ⓬ [●] (Redial/Pause)
- ⓭ [⏻] (Off/Power)
- ⓮ [C/⊗] (Clear/Mute)
- ⓯ Dial keypad
- ⓰ [INT] (Intercom)
- ⓱ Microphone

6 Installation Instructions

6.1. Connections

Base unit

When connecting the AC adaptor to the base unit, a short beep will be heard. If it is not heard, check the connections.

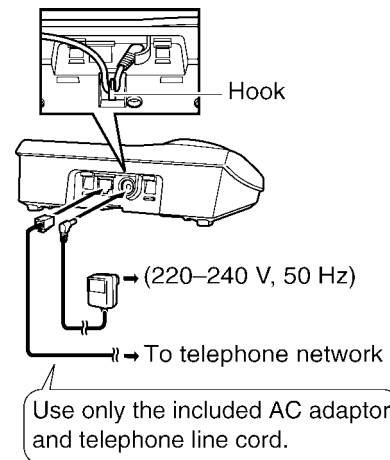

Charger

Connect the AC adaptor to the charger and route the cable as shown. The charger can be mounted on the wall, if required.

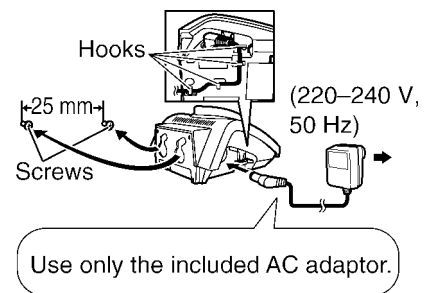

Note:

- Never install telephone wiring during a lightning storm.
- The AC adaptor must remain connected at all times. (It is normal for the adaptor to feel warm during use.)
- The AC adaptor should be connected to a vertically oriented or floor-mounted AC outlet. Do not connect the AC adaptor to a ceiling-mounted AC outlet, as the weight of the adaptor may cause it to become disconnected.
- **The unit will not work during a power failure.** We therefore recommend you also connect a corded-type telephone (without AC adaptor) to the same telephone line using a T-adaptor. Your Panasonic sales shop can offer you more information about connection possibilities.

Location

- For maximum distance and noise-free operation, place your base unit:
 - away from electrical appliances such as TVs, radios, personal computers or other phones.
 - in a convenient, high and central location.

6.2. Battery

6.2.1. Battery Installation/Replacement

Important:

- Use only the included rechargeable batteries HHR-55AAAB or HHR-4EPT.
- When replacing batteries, we recommend using the Panasonic rechargeable batteries P03P.

- 1 Press the notch on the handset cover firmly and slide it in the direction of the arrow.
 - When replacing batteries, remove the old batteries positive (+) terminal first.

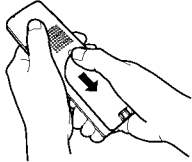

- 2 Insert the batteries negative (-) terminal first. Close the handset cover.

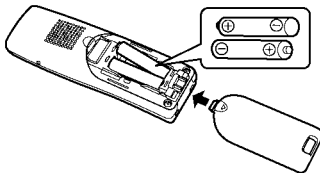

6.2.2. Battery Charge

Place the handset on the base unit or charger for about 7 hours before initial use.

When charging, the battery icon is shown as follows.

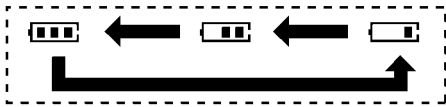

When the batteries are fully charged,  remains on the display.

- The charge indicator lights up when the handset is placed on the base unit or charger.

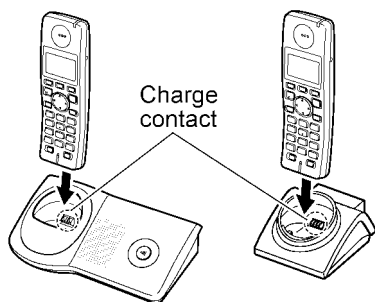

Base unit **Charger**



Note:

- It is normal for the handset to feel warm during charging.
- If you want to use the unit immediately, charge the batteries for at least 15 minutes.
- Clean the charge contacts of the handset, base unit, and charger with a soft, dry cloth, otherwise the batteries may not charge properly. Clean if the unit is exposed to grease, dust or high humidity.

6.2.3. Battery Strength

Battery icon	Battery strength
	High
	Medium
	Low When flashing: Needs to be charged.

6.2.4. Panasonic Ni-MH Battery Performance (included batteries)

Operation	Operating time
In continuous use	17 hours max.
In continuous standby mode	180 hours max.

Note:

- It is normal for batteries not to reach full capacity at the initial charge. Maximum battery performance is reached after a few complete cycles of charge/discharge (use).
- Actual battery performance depends on a combination of how often the handset is in use and how often it is not in use (standby).
- Battery operating time may be shortened over time depending on usage conditions and ambient temperature.
- Even after the handset is fully charged, the handset can be left on the base unit or charger without any ill effect on the batteries.
- The battery strength may not be displayed correctly after you replace the batteries. In this case, place the handset on the base unit or charger and charge for at least 7 hours.

7 Operation Instructions

7.1. Base Unit Settings

- Use the handset to customise the base unit.
- When customising the base unit, the current item or setting is indicated by ▶.

To customise the base unit:

- 1 [≡/OK]
- 2 Press [▲] or [▼] to select “Base Unit Setup”. → [▶]
- 3 Press [▲] or [▼] to select the desired item in the base unit settings menu. → [▶]
- 4 Press [▲] or [▼] to select the desired item in the sub-menu. → [▶]
- 5 Press [▲] or [▼] to select the desired setting then press [▶] or follow the instruction in the “Feature” column of the chart.
 - To exit the operation, press [✕⓪].

Base unit settings menu	Sub-menu	Feature (default setting)	Remarks (Selectable options)
Ringer Volume	—	Base unit ringer volume (<i>Medium</i>)	Off/Low/Midium/High*4
Call Options	Recall/Flash	Change the recall time (“100 msec.”). ^{*1}	80/90/100/110/160/200/250/300/400/600/700/900 msec
	Call Restrict	—	Off/On (Up to 6 Numbers)
Other Options	Base Unit PIN	Change base unit PIN (“0000”). ^{*2} – Enter the current 4-digit base unit PIN. ^{*3} → Enter the new 4-digit base unit PIN. → [≡/OK]	"0000" - "9999" (4 digits)
	Repeater Mode	(“Off”)	On/Off

*1 Change the recall time, if necessary, depending on the requirements of your service provider/telephone company or PBX.

*2 If you forget your PIN, see **For Service Hint** (P.20).

*3 If you change the PIN, please make note of your new PIN. The unit will not reveal the PIN to you.

*4 The items are not shown on the display.

7.2. Handset Settings

- When customising the handset, the current item or setting is indicated by ▶.

To customise the handset:

1 [☰/OK]

2 Press [▲] or [▼] to select “Handset Setup”. → [▶]

3 Press [▲] or [▼] to select the desired item in the handset settings menu. → [▶]

4 Press [▲] or [▼] to select the desired item in the sub-menu. → [▶]

5 Press [▲] or [▼] to select the desired setting then press [▶] or follow the instruction in the “Feature” column of the chart.

- To exit the operation, press [✕].

Handset settings menu	Sub-menu	Feature (default setting)	Remarks (Selectable options)
Set Date & Time	—	Date and time	—
Ringer Setup	Ringer Volume	Handset ringer volume (<i>Maximum</i>) ^{*1}	Off/Volume 1 to 6 ^{*6}
	Ext. Ringtone (<i>External ringtone</i>)	Ringtones for outside calls (“Ringtone 1”) ^{*2}	10 (5 tone + 5 melody)
	Int. Ringtone (<i>Intercom ringtone</i>)	Ringtones for intercom calls (“Ringtone 3”) ^{*3}	10 (5 tone + 5 melody)
Display Setup	Standby Display	Standby mode display (“Off”) ^{*4}	Off/Handset Number
	Select Language	Display language (“English”)	14 languages selectable
	Contrast	Display contrast (<i>Level 3</i>)	Contrast 1 to 6 ^{*6}
Registration	Register H.set (<i>Register handset</i>)	See “ Registering a Handset to the Base Unit ”	—
Other Options	Keytones	Keytones on/off (“On”)	On/Off
	Auto Talk	Auto talk on/off (“Off”) ^{*5}	On/Off

*1 When the ringer is turned off, the handset will ring:

- at the minimum level for intercom calls
- at the maximum level for paging

*2 If you select one of the melody ringtones, the ringtone will continue to sound for several seconds if the caller hangs up before you answer. You may hear a dial tone or no one on the line when you answer a call.

The preset melodies in this product are used with permission of © 2004 M-ZoNE Co., Ltd.

*3 The preset melodies in this product are used with permission of © 2004 M-ZoNE Co., Ltd.

*4 If “Off” is selected, only current date and time are displayed.

If “Handset Number” is selected and the current handset number is 2, “[2]” is displayed.

*5 Auto talk feature allows you to answer calls simply by lifting the handset off the base unit or charger. You do not need to press [↵].

*6 The items are not shown on the display.

Cross Reference:

Registering a Handset to the Base Unit (P.19)

7.3. Registering a Handset to the Base Unit

The included handset and base unit are preregistered. If for some reason the handset is not registered to the base unit (for example, ∇ flashes even when the handset is near the base unit), register the handset manually.

To register an additional handset to the base unit (easy registration)

After purchasing an additional handset, register it to the base unit. Ensure that the additional handset is switched on. If it is not on, press and hold **[\times ⓪]** for few seconds to turn the handset on.

- 1 Lift the additional handset and press **[\times ⓪]** to put the handset in standby mode.
- 2 Press and hold **[$\bullet\bullet$]** on the base unit for about 3 seconds, until the registration tone sounds.
- 3 Place the additional handset on the base unit. The registration tone continues to sound. With the handset still on the base unit, wait until a confirmation tone sounds and ∇ stops flashing.

Note:

- If an error tone sounds, or if ∇ is still flashing, register the handset manually.
- If all registered handsets start ringing in step 2, press **[$\bullet\bullet$]** to stop. Start again from step 1.
- Charge the batteries of your additional handset for about 7 hours before initial use.
- This registration method cannot be used for handsets that have already been registered to the base unit. Register the handset manually.

To register a handset to the base unit (manual registration)

You can register a handset to the base unit manually using the following method.

- 1 **[\square /OK]** → “Handset Setup” → **[▶]**
- 2 “Registration” → **[▶]**
- 3 “Register H.set” → **[▶]**
- 4 Press and hold **[$\bullet\bullet$]** on the base unit for about 3 seconds, until the registration tone sounds.
 - If all registered handsets start ringing, press **[$\bullet\bullet$]** to stop, then repeat this step.
 - After pressing **[$\bullet\bullet$]**, the rest of this procedure must be completed within 1 minute.
- 5 Wait until “Enter Base PIN” is displayed, then enter the base unit PIN (default: “0000”), then press **[\square /OK]**.
 - If you forget your PIN, see **For Service Hint**.
 - When the handset has been registered successfully, ∇ will stop flashing. If keytones are turned on, a confirmation tone will be heard.

Cross Reference:

For Service Hint (P.20)

7.3.1. Cancelling a handset

A maximum of 6 handsets can be registered to the base unit. A handset can cancel its own registration (or the registration of another handset) that is stored in the base unit. This will allow the base unit to “forget” the handset.

- 1 **[\square /OK]** → “Base Unit Setup” → **[▶]**
- 2 Enter “335”.
- 3 “Cancel Handset” → **[▶]**
 - The numbers of all handsets registered to the base unit are displayed.
- 4 Select the handset(s) you want to cancel, by pressing the desired handset number. → **[\square /OK]**
 - The selected handset number(s) will flash.
 - To cancel a selected handset number, press the number again. The number will stop flashing.
- 5 “Yes” → **[▶]** → **[\times ⓪]**

7.4. For Service Hint

Items	Contents
Battery	You could use other rechargeable batteries sold in a market, but the unit is not guaranteed to work properly.
PIN Code	<ul style="list-style-type: none"> • If you forget the PIN, change the PIN using the following method. 1 [OK] 2 Press [▲] or [▼] to select “Base Unit Setup”. → [▶] 3 “Other Options” → [▶] 4 “Base Unit PIN” → [▶] 5 Press [*][7][0][0]. 6 Enter the new 4-digit base unit PIN. → [▶] → [X]
Recall	Earth Recall feature is not supported in this model.

8 Service Mode

8.1. Engineering Mode

8.1.1. Base Unit

Important:

Make sure the address on LCD is correct when entering new data. Otherwise, you may ruin the unit.

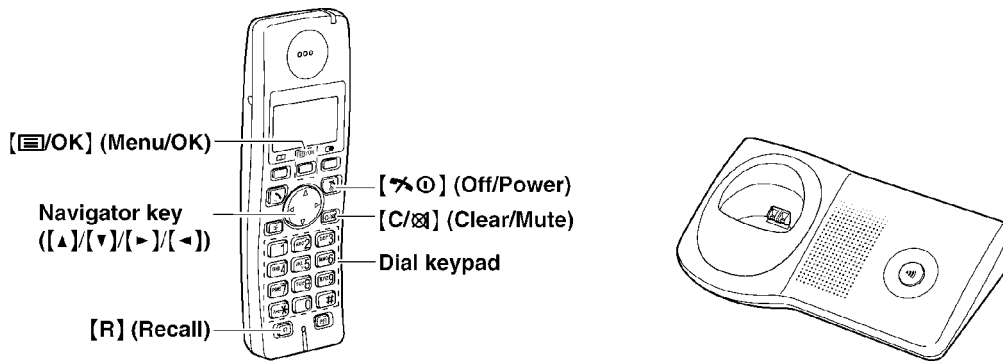

H/S key operation

- 1). Register a Handset to a Base Unit. (*1)
- 2). Press [Menu/OK].
- 3). Select "Base Unit Setup" using [Up] or [Down] then press [Menu/OK] or [Right].
- 4). Enter "7", "2", "6", "2", "7", "6", "6", "4".
Note: 7262 7664 = PANA SONI
 (see alphabets printed on dial keys)
- 5). Select "Write EEPROM" using [Up] or [Down] then press [Menu/OK] or [Right].
- 6). Enter "0", "0", "0", "0" (Address). (*2)
- 7). Enter "*" , "*" (New Data). (*2)
- 8). Press [Menu/OK], a long confirmation beep will be heard.
- 9). Press [Off/Power] (off) to return to standby mode.
 After that, turn the base unit power off and then power on.

H/S LCD

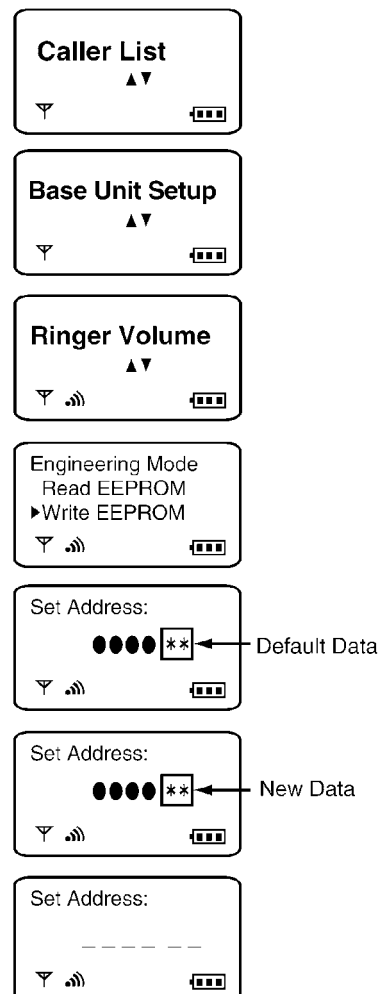

Frequently Used Items (Base Unit)

ex.)

Items (*3)	Address	Default Data	New Data		Remarks
C-ID (FSK) sensitivity	04 3E	00	01 (6dB up)	02 (12dB up)	When hex changes from "00" to "01" or "02", gain increases by 6dB or 12dB.
C-ID (DTMF) sensitivity	04 4C	50	60 (6dB up)	70 (12dB up)	When hex changes from "50" to "60" or "70", gain increases by 6dB or 12dB.
Frequency	00 01	75	-	-	Use these items in a READ-ONLY mode to confirm the contents. Careless rewriting may cause serious damage to the computer system.
ID	00 10~00 14	Given value	-	-	
Bell length	01 F6	32 (5sec) (*4)	1E (3sec)	14 (2sec)	This is time until bell stops ringing. (Unit: 100ms)

Note:

(*1) Refer to **Registering a Handset to the Base Unit** (P.19).

(*2) When you enter the address or New Data, please refer to the table below.

Desired Number (hex.)	Input Keys	Desired Number (hex.)	Input Keys
0	0	A	[R] + 0
1	1	B	[R] + 1
.	.	C	[R] + 2
.	.	D	[R] + 3
.	.	E	[R] + 4
9	9	F	[R] + 5

(*3)

Items	Description
C-ID (FSK) sensitivity	FSKGain_shiftgain
C-ID (DTMF) sensitivity	Foutgains:HPFilter Foutgains
Frequency	Setting value of FREQ_TRIM_REG
ID	ID
Bell length	Time until it stops bell.

(*4)

Bell length	32(hex) = 50(dec) → 50 × 100msec = 5000msec (5sec)
-------------	--

8.1.2. Handset

Important:

Make sure the address on LCD is correct when entering new data. Otherwise, you may ruin the unit.

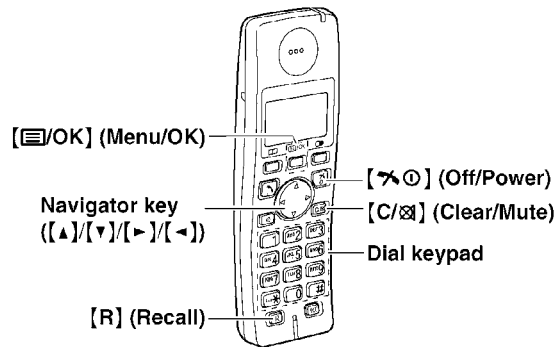

H/S key operation

- 1). Press [M]/[OK].
- 2). Select "Handset Setup" using [▲] or [▼] then press [M]/[OK] or [▶].
- 3). Enter "7", "2", "6", "2", "7", "6", "6", "4".
Note: 7262 7664 = PANA SONI
(see alphabets printed on dial keys)

- 4). Select "Write EEPROM" using [▲] or [▼] then press [M]/[OK] or [▶].

- 5). Enter "●", "●", "●", "●" (Address). (*1)

- 6). Enter " * ", " * " (New Data). (*1)

- 7). Press [M]/[OK], a long confirmation beep will be heard.

- 8). Press [⏻] (off) to return to standby mode.

After that, remove and reinsert the batteries. Press the Power button for about 1 second if the power is not turned on.

H/S LCD

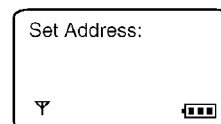
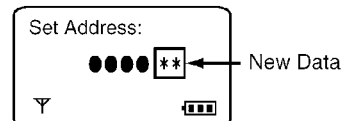
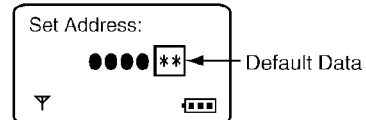
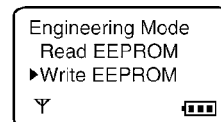
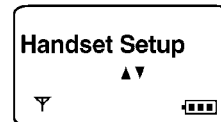

Frequently Used Items (Handset)

ex.)

Items (*2)	Address	Default Data	New Data	Possible Adjusted Value MAX (hex)	Possible Adjusted Value MIN (hex)	Remarks
Sending level	00 06	Adjusted value	Given value	6F	00	(*3)
Receiving level	00 07	Adjusted value	Given value	00	3F	(*4)
Battery Low	00 04	25	-	-	-	(*5)
Frequency	00 01	75	-	-	-	
ID	00 10~00 14	Given value	-	-	-	

Note:

(*1) When you enter the address or New Data, please refer to the table below.

Desired Number (hex.)	Input Keys	Desired Number (hex.)	Input Keys
0	0	A	[R] + 0
1	1	B	[R] + 1
.	.	C	[R] + 2
.	.	D	[R] + 3
.	.	E	[R] + 4
9	9	F	[R] + 5

(*2)

Items	Description
Sending level	Analog Front End MIC Setting for Handset Mode
Receiving level	Analog Front End LSR Setting for Handset Mode
Battery Low	ADC value for battery low detection
Frequency	Setting value of FREQ_TRIM_REG
ID	International Portable Part Equipment Identities

(*3) When adding "01" (hex) to default value, sending level increases by 0.25 dB.

ex.)

Item	Default Data			New Data		
	3A	3E	36			
Sending level	-8dBm	-7dBm	-9dBm			

(*4) When reducing "01" (hex) from default value, receiving level increases by 0.25 dB.

ex.)

Item	Default Data			New Data		
	14	18	10			
Receiving level	-21dBm	-22dBm	-20dBm			

(*5) Use these items in a READ-ONLY mode to confirm the contents. Careless rewriting may cause serious damage to the handset.

9 Troubleshooting Guide

9.1. Troubleshooting Flowchart

Flow Chart

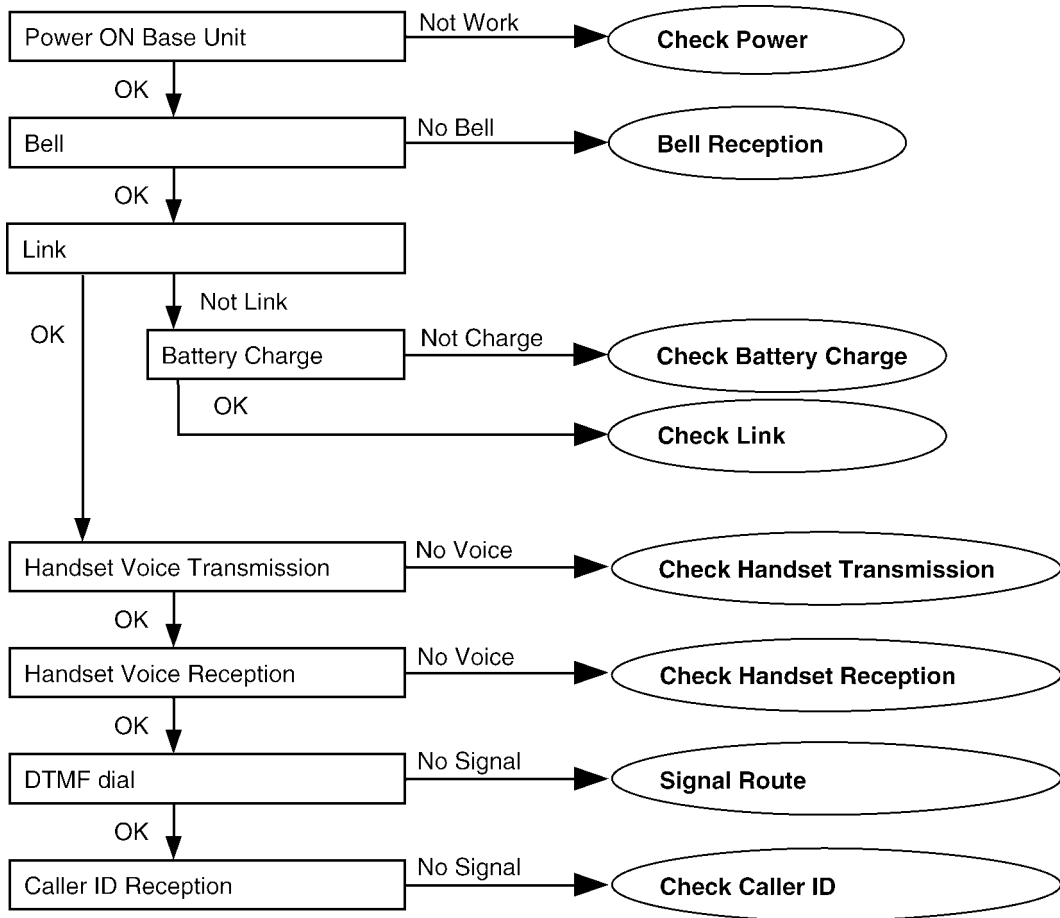

Cross Reference:

Check Power (P.26)

Bell Reception (P.33)

Check Battery Charge (P.27)

Check Link (P.28)

Check Handset Transmission (P.32)

Check Handset Reception (P.32)

Signal Route (P.14)

Check Caller ID (P.32)

9.1.1. Check Power

9.1.1.1. Base Unit

Is the AC Adaptor inserted into AC outlet? (*1)

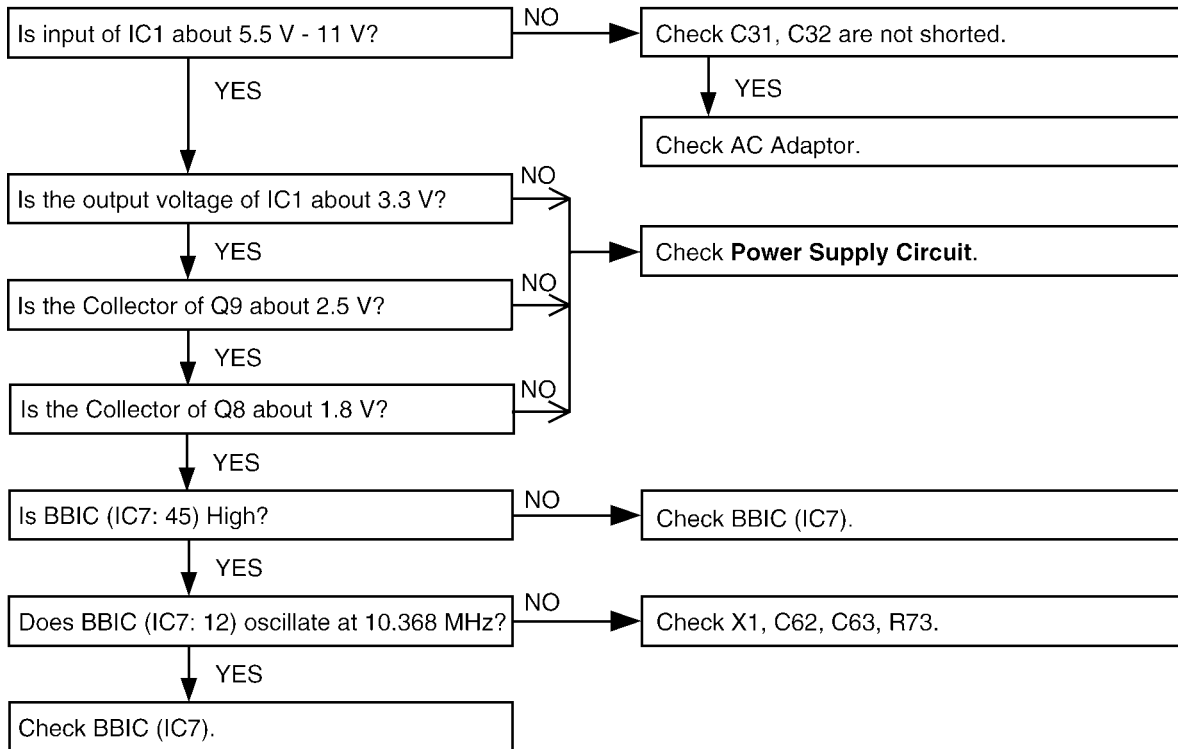

Cross Reference:
Power Supply Circuit (P.9)

Note:
 (*1) Refer to **Specifications (P.6)** for part number and supply voltage of AC Adaptor.

9.1.1.2. Handset

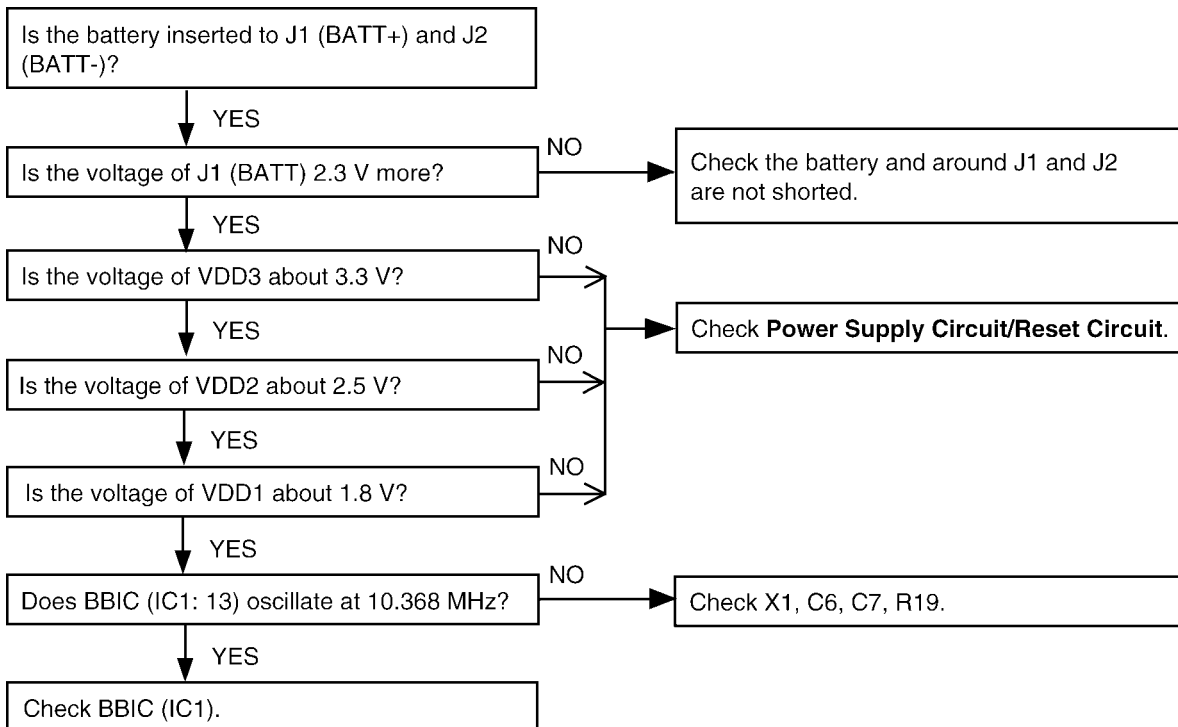

Cross Reference:
Power Supply Circuit/Reset Circuit (P.12)

9.1.2. Check Battery Charge

9.1.2.1. Base Unit

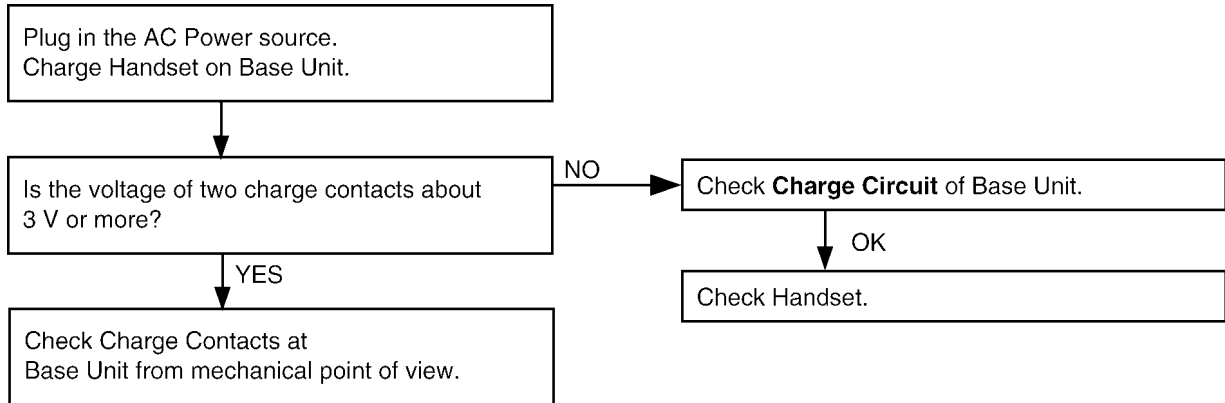

Cross Reference:

Charge Circuit (P.12)

9.1.2.2. Handset

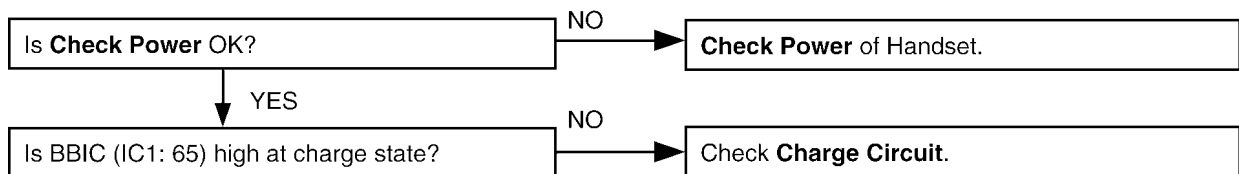

Cross Reference:

Check Power (P.26)

Charge Circuit (P.12)

9.1.2.3. Charger Unit

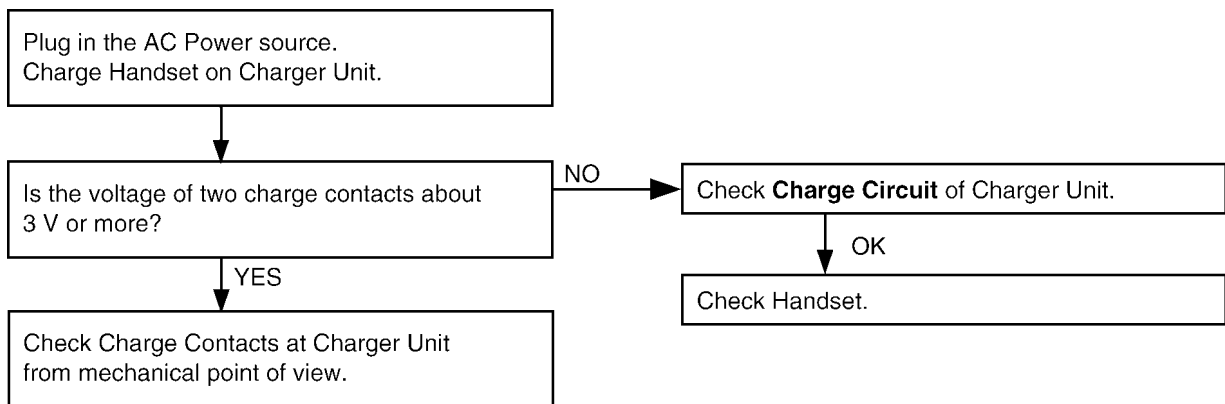

Cross Reference:

Charge Circuit (P.12)

9.1.3. Check Link

9.1.3.1. Base Unit

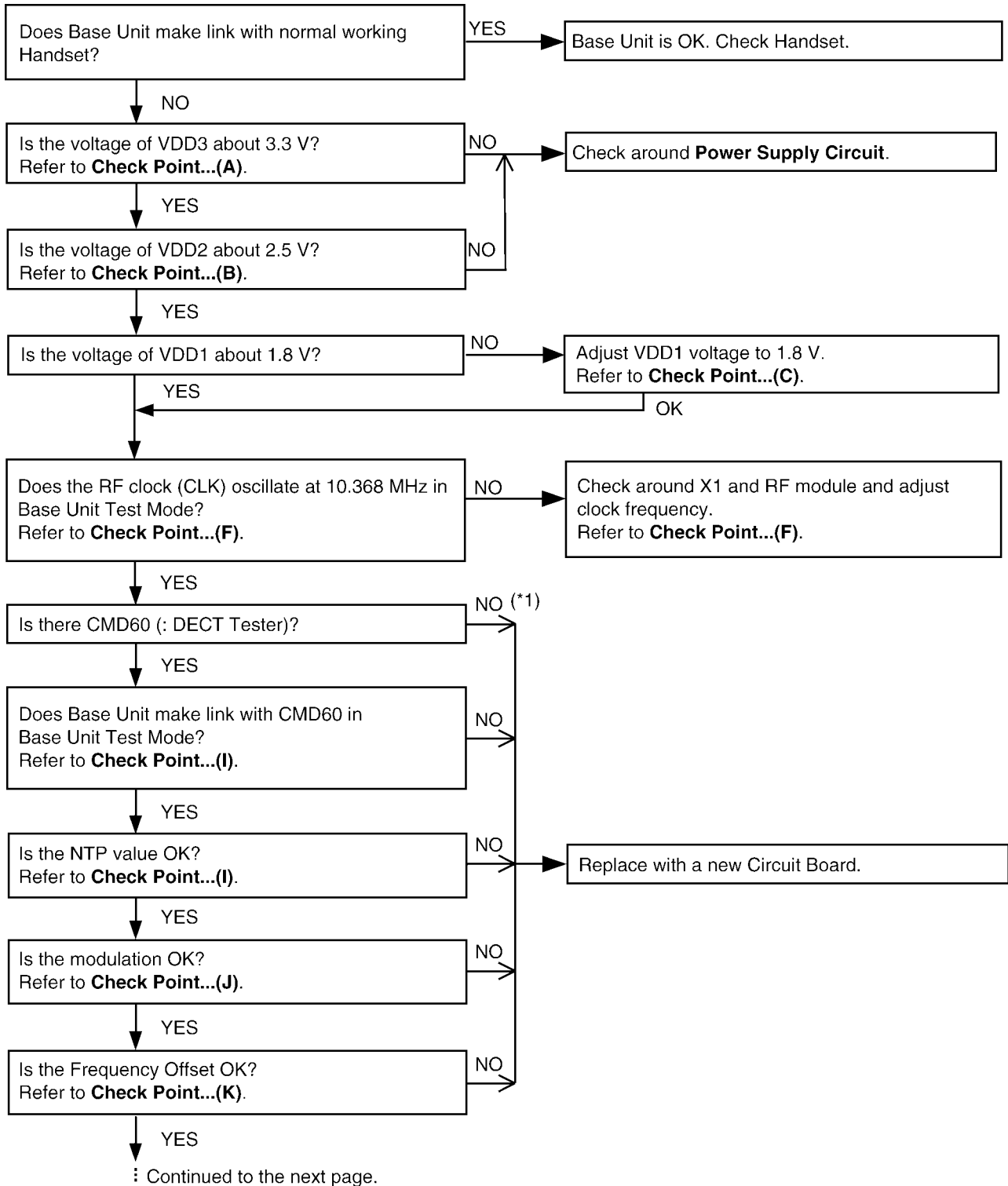

Note:

(*1) Refer to **Troubleshooting by Symptom (Base Unit and Charger Unit)** (P.34)

Cross Reference:

Check Point (Base Unit) (P.34)

Power Supply Circuit (P.9)

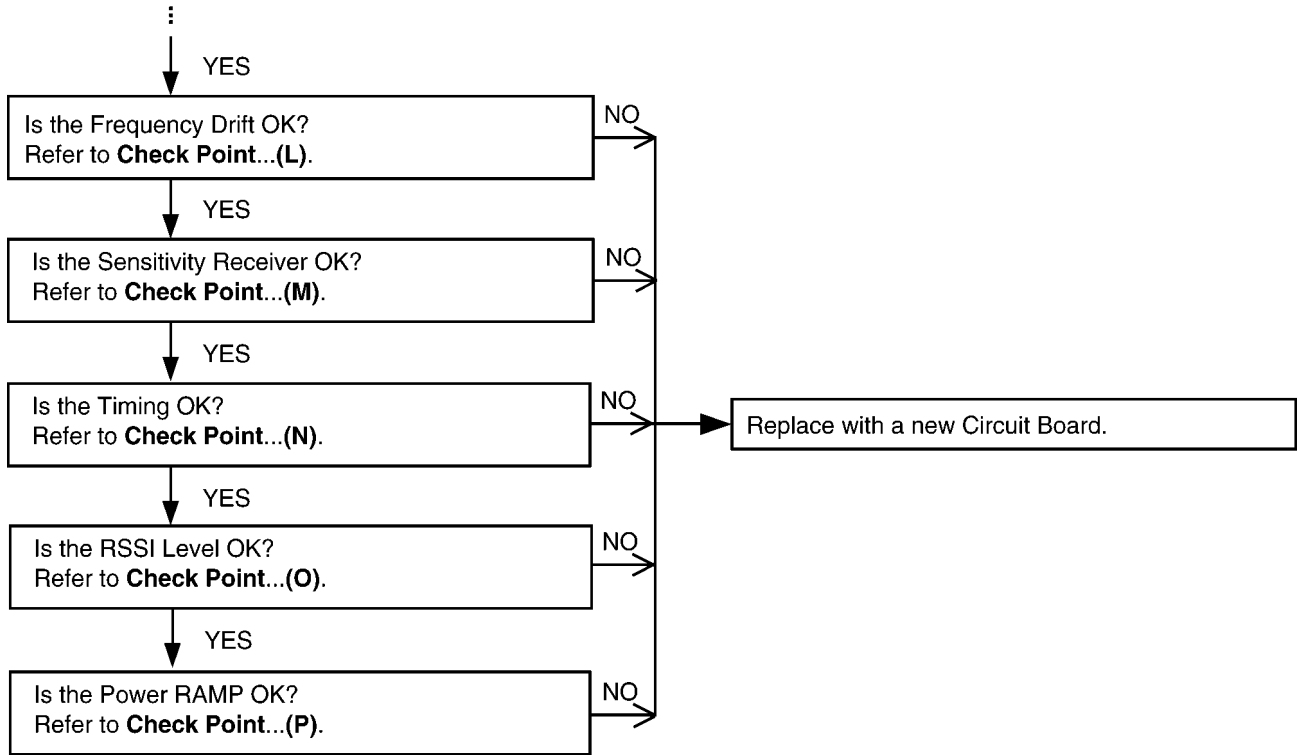

Cross Reference:
Check Point (Base Unit) (P.34)

9.1.3.2. Handset

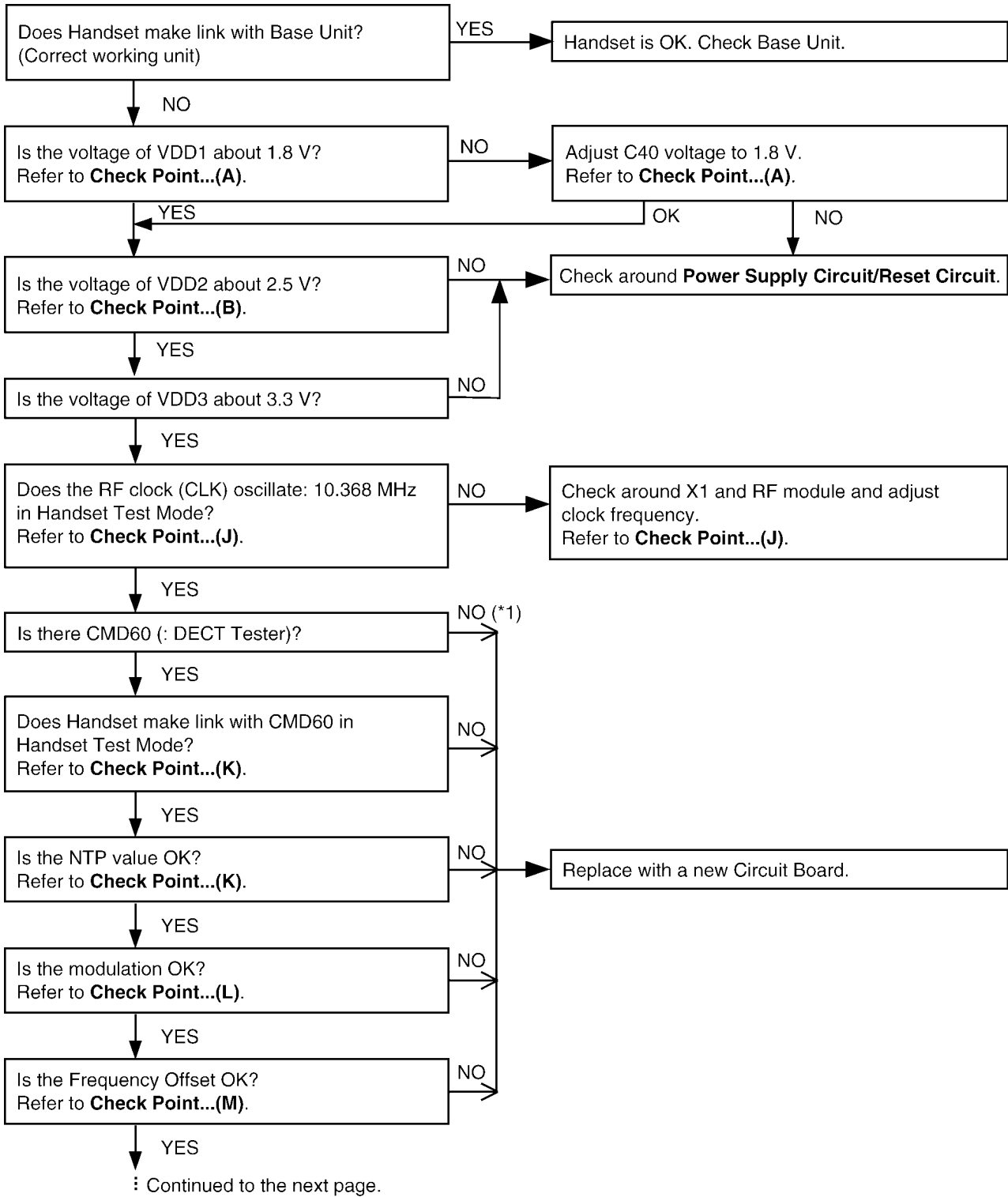

Note:

(*1) Refer to **Troubleshooting by Symptom (Handset)** (P.38)

Cross Reference:

Check Point (Handset) (P.38)

Power Supply Circuit/Reset Circuit (P.12)

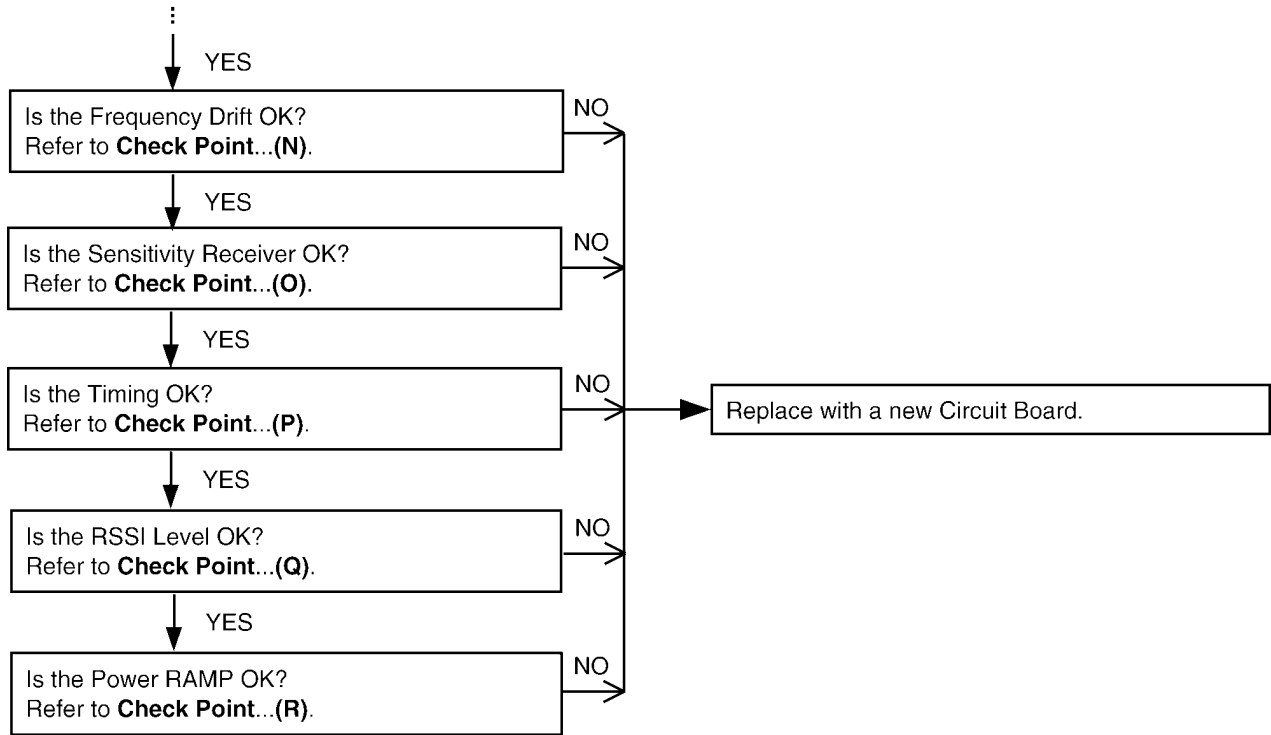

Cross Reference:
Check Point (Handset) (P.38)

9.1.4. Check Handset Transmission

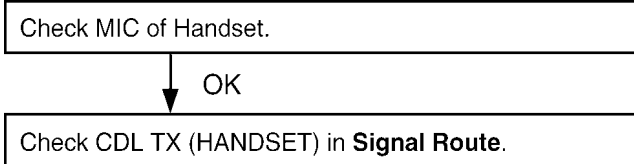

Cross Reference:

Signal Route (P.14)

9.1.5. Check Handset Reception

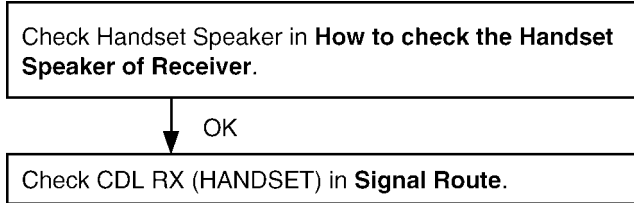

Cross Reference:

How to Check the Handset Speaker of Receiver (P.56).

Signal Route (P.14)

9.1.6. Check Caller ID



Cross Reference:

Signal Route (P.14)

9.1.7. Bell Reception

9.1.7.1. Base Unit

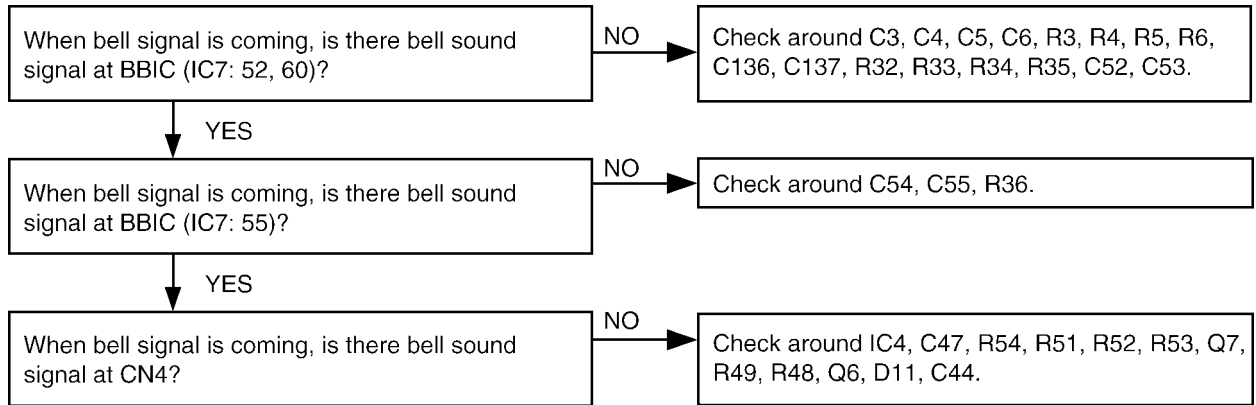

9.1.7.2. Handset

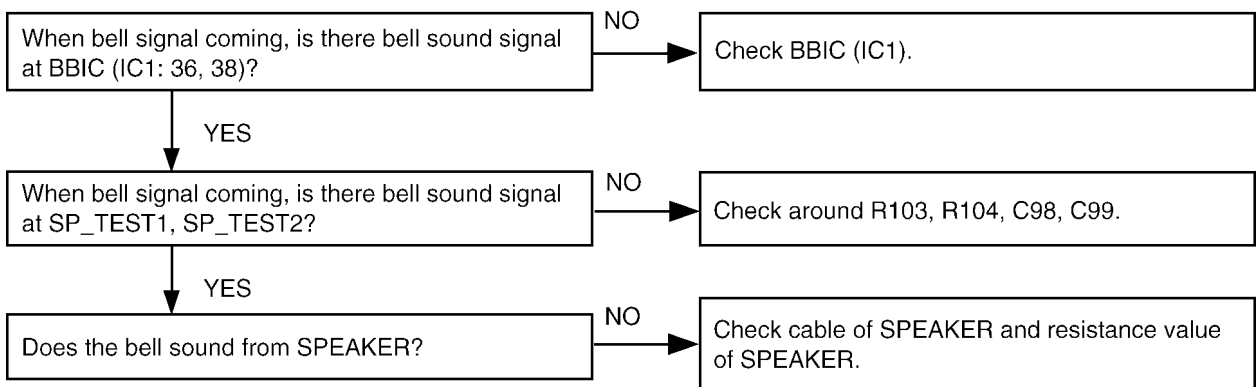

Cross Reference:

Telephone Line Interface (P.9)

Check Link (P.28)

How to Check the Handset Speaker of Receiver (P.56)

9.2. Troubleshooting by Symptom (Base Unit and Charger Unit)

If your unit has below symptoms, follow the instructions in remedy column. Remedies depend on whether you have DECT tester (*1) or not.

Symptom	Remedy (*2)	
	You don't have DECT Tester.	You have DECT Tester. (Model Number : CMD60)
You cannot dial.	Check item (A)-(H).	Check item (A)-(H), (I)-(P).
You cannot hear the caller's voice.	Check item (A)-(F).	Check item (A)-(F), (I)-(P), (Q).
You cannot use handset a little away from base unit even if the handset is within range of the base unit.	-	Check item (I)-(P).
The acoustic transmit level is high or low.	Check item (Q).	Check item (Q).
The acoustic reception level is high or low.	Check item (Q).	Check item (Q).
Base unit and handset do not link each other.	Check item (A)-(H).	Check item (A)-(P).
The unit cannot charge.	Check item (R).	Check item (R).

Note:

(*1) A general repair is possible even if you don't have the DECT tester because it is for confirming the levels, such as Acoustic level in detail.

(*2) Refer to **Check Point (Base Unit)** (P.34)

9.2.1. Check Point (Base Unit)

Please follow the items below when BBIC or EEPROM is replaced.

Note:

After the measuring, suck up the solder of TP.

*: **PC Setting** (P.47) is required beforehand.

The connections of simulator equipments are as shown in **Adjustment Standard (Base Unit)** (P.49).

	Items	Check Point	Procedure	Check or Replace Parts				
(A)	3.3 V Supply Confirmation	VDD3	1. Confirm that the voltage between test point VDD3 and GND is $3.3\text{ V} \pm 0.2\text{ V}$.	IC1, C31, C32, R38, R39, C36, C37				
(B)	2.5 V Supply Confirmation	VDD2	1. Confirm that the voltage between test point VDD2 and GND is $2.5\text{ V} \pm 0.2\text{ V}$.	Q9, C70, C71				
(C)*	1.8 V Supply Confirmation	VDD1	1. Confirm that the voltage between test point VDD1 and GND is $1.8\text{ V} \pm 0.1\text{ V}$.	Q8, R72, D12, C68				
(D)*	BBIC Confirmation	-	1. BBIC Confirmation (Execute the command "getchk"). 2. Confirm the returned checksum value. Connection of checksum value and program number is shown below. ex.) <table border="1" style="display: inline-table; vertical-align: middle;"> <tr> <td>checksum value</td> <td>program number</td> </tr> <tr> <td>9B43</td> <td>D611ZC</td> </tr> </table>	checksum value	program number	9B43	D611ZC	IC7, R37, C62, C63, X1, C72, R75~R81, R62, R63
checksum value	program number							
9B43	D611ZC							
(E)*	EEPROM Confirmation	-	1. EEP-ROM Confirmation (Execute the command "ChkTG7100XXrevYY.bat"). XX: country code YY: revision number 2. Confirm the returned checksum value. 3. The checksum is displayed in the last output line. Note: "XX", "YY", and "checksum" vary depending on the country version. You can find them in the batch file, PQZZ- mentioned in JIG and PC (P.47).	IC5, C51, R62, R63, Q14, C50, R57~R61				
(F)*	BBIC Clock Adjustment	CLK	1. Input Command "rdeeprom 00 01 01", then you can confirm the current value. 2. Adjust the frequency of CLK executing the command "setfreq xx (where xx is the value)" so that the reading of the frequency counter is $10.368000\text{ MHz} \pm 10\text{ Hz}$.	IC10, C111, C112, X1, R73, C62, C63				

	Items	Check Point	Procedure	Check or Replace Parts
(G)*	Hookswitch Check with DC Characteristics	-	<ol style="list-style-type: none"> 1. Connect CN1 (Telephone Socket) to Tel-simulator which is connected with 600 Ω. 2. Set line voltage to 48 V and line current to 40mA at off-hook condition of normal telephone. 3. Execute the command "hookoff" 4. Confirm that the line current is 40 mA \pm 5 mA. 5. Execute the command "hookon". 6. Confirm that the line current is less than + 0.8 mA. 	L1, L2, Q3, R14, R15, Q4, R16, R17, IC7, D3
(H)*	DTMF Generator Check	-	<ol style="list-style-type: none"> 1. Connect CN1 (Telephone Socket) to DTMF tester. (Road=600 Ω) 2. Link Handset and push dial key. 3. Confirm DTMF character. 4. Confirm that the high Group is -6.0 dBm \sim -10.0 dBm. 5. Confirm that the low Group is -8.5 dBm \sim -12.5 dBm. 	IC7, R67, IC6, R116, C141, R29, C22, C23, R18~R24, C14~C17, Q5, D4
(I)*	Transmitted Power Confirmation	-	<p>Remove the Antenna before starting step from 1 to 7.</p> <ol style="list-style-type: none"> 1. Configure the DECT tester (CMD60) as follows; <ul style="list-style-type: none"> <Setting> • Short A_1 and GND. • Test mode: FP • Traffic Carrier: 5 • Traffic Slot: 4 • Mode: Loopback • PMID: 00000 • RF LEVEL = -70dBm. 2. Execute the command "testmode". 3. Execute the command "sendchar dmv 2 2". 4. Check that "Signalling Status" has been set to "Locked", then press "ACCEPT RFPI". 5. Initiate connection from Dect tester ("set up connect") 6. Execute the command "ANT1". 7. Confirm that the NTP value at ANT is 20 dBm \sim 25 dBm. 	IC7, IC10, L7, L3, L4, L6, C117, C118, C119, C120, C124, C125, R106, R109, DA1, C102, R102, R103, Q10, C110, C112, R111, C126, C127, R112
(J)	Modulation Check and Adjustment	-	<p>Follow steps 1 to 6 of (I).</p> <ol style="list-style-type: none"> 7. Confirm that the B-Field Modulation is -350 \sim -400/+320 \sim +370 kHz/div using data type Fig31. 8. Adjust the B-Field Modulation if required. (Execute the command "readmod" and "wrtmod xx", where xx is the value.) 	IC7, IC10, L7, L3, L4, L6, C117, C118, C119, C120, C124, C125, R106, R109, DA1, C102, R102, R103, Q10, C110, C112, R111, C126, C127, R112
(K)	Frequency Offset Check	-	<p>Follow steps 1 to 6 of (I).</p> <ol style="list-style-type: none"> 7. Confirm that the frequency offset is $< \pm$ 45 kHz. 	IC7, IC10, L7, L3, L4, L6, C117, C118, C119, C120, C124, C125, R106, R109, DA1, C102, R102, R103, Q10, C110, C112, R111, C126, C127, R112
(L)	Frequency Drift Confirmation	-	<p>Follow steps 1 to 6 of (I).</p> <ol style="list-style-type: none"> 7. Confirm that the frequency drift is $< \pm$ 30 kHz/ms. 	IC7, IC10, L7, L3, L4, L6, C117, C118, C119, C120, C124, C125, R106, R109, DA1, C102, R102, R103, Q10, C110, C112, R111, C126, C127, R112

	Items	Check Point	Procedure	Check or Replace Parts
(M)	Sensitivity Receiver Confirmation	-	Follow steps 1 to 6 of (I). 7.Set DECT tester power to -90 dBm. 8.Confirm that the BER is < 1000 ppm.	IC7, IC10, L7, L3, L4, L6, C117, C118, C119, C120, C124, C125, R106, R109, DA1, C102, R102, R103, Q10, C110, C112, R111, C126, C127, R112
(N)	Timing Confirmation	-	Follow steps 1 to 6 of (I). 7.Confirm that the Timing accuracy is < ± 2.0 ppm.	IC7, IC10, L7, L3, L4, L6, C117, C118, C119, C120, C124, C125, R106, R109, DA1, C102, R102, R103, Q10, C110, C112, R111, C126, C127, R112
(O)*	RSSI Level Confirmation	-	Follow steps 1 to 6 of (I). 7.Execute the command "readrssi". 8. Confirm that the returned value is 22 ± A (hex).	IC7, IC10, L7, L3, L4, L6, C117, C118, C119, C120, C124, C125, R106, R109, DA1, C102, R102, R103, Q10, C110, C112, R111, C126, C127, R112
(P)	Power RAMP Confirmation	-	Follow steps 1 to 6 of (I). 7.Confirm that Power RAMP is matching.	IC7, IC10, L7, L3, L4, L6, C117, C118, C119, C120, C124, C125, R106, R109, DA1, C102, R102, R103, Q10, C110, C112, R111, C126, C127, R112
(Q)*	Audio Check	-	1. Link with Handset. 2. Input -45dBm/1kHz to MIC of Handset. Measure the Level at Line I/F and distortion level. 3. Confirm that the level is -8 dBm ± 2 dBm and that the distortion level is < 5% at TEL Line (600 Ω Load). 4. Input -20 dBm/1 kHz to Line I/F. Measure the level at Receiver of Handset and distortion level (*Receive volume set to second position from minimum). 5. Confirm that the level is -21 dBm ± 2 dBm and that the distortion level is < 5% at Receiver (Volume Middle, 150 Ω Load).	IC7, CN1, SA1, L1, L2, D3, Q3, Q4, R14, R15, R16, R17
(R)	Charging Check	-	1. Connect Charge Contact 12 Ω/2 W resistor between charge+ and charge-. 2. Measure and confirm voltage across the resistor is 3.10 V ± 0.2 V.	R55, R56, C48, C49

9.2.2. Check Point (Charger Unit)

	Items	Check Point	Procedure	Check or Replace Parts
(A)	Charging Check	-	1. Connect Charge Contact 12 Ω /2 W resistor between charge+ and charge-. 2. Measure and confirm voltage across the resistor is 3.3 V \pm 0.2 V.	R2, R1 R3, R4

Note:

After the measuring, suck up the solder of TP.

The connection of adjustment equipment is as shown in **Adjustment Standard (Charger Unit)** (P.50).

9.3. Troubleshooting by Symptom (Handset)

If your unit has below symptoms, follow the instructions in remedy column. Remedies depend on whether you have DECT tester (*1) or not.

Symptom	Remedy (*2)	
	You don't have DECT Tester.	You have DECT Tester. (Model Number : CMD60)
Battery strength is not indicated correctly by Battery icon.	Check item (A)-(D), (G)-(H).	Check item (A)-(D), (H)-(I).
You cannot hear the caller's voice.	Check item (A)-(D), (J).	Check item (A)-(D), (J)-(M), (N), (P).
You cannot use handset a little away from base unit even if the handset is within range of the base unit.	-	Check item (K), (O).
Does not link between base unit and handset.	Check item (A)-(D), (J).	Check item (A)-(D), (J)-(Q).
The Audio level is high or low.	Check item (S).	Check item (S).
The SP-Phone level is high or low.	Check item (T).	Check item (T).

Note:

(*1) A general repair is possible even if you don't have the DECT tester because it is for confirming the levels, such as Acoustic level in detail.

(*2) Refer to **Check Point (Handset)** (P.38)

9.3.1. Check Point (Handset)

Please follow the items below when BBIC or EEPROM is replaced.

Note:

After the measuring, suck up the solder of TP.

*: **PC Setting** (P.51) is required beforehand.

The connections of adjustment equipments are as shown in **Adjustment Standard (Handset)** (P.53).

	Items	Check Point	Procedure	Check or Replace Parts				
(A)*	1.8V Supply Adjustment	VDD1	1. Confirm that the voltage between test point VDD1 and GND is 1.8V ± 0.02V. 2. Execute the command "bandgap", then check the current value. 3. Adjust the 1.8V voltage of VDD1 executing command "bandgap XX"(XX is the value).	IC1, Q2, C10				
(B)	DC/DC Supply Confirmation	VDD3	1. Confirm that the voltage between test point VDD3 and GND is 3.3V ± 0.3V (Backlight is ON).	IC1, F1, C1, C2, C3, R1, Q1, D1, L1				
(C)	2.5V Supply Confirmation	VDD2	1. Confirm that the voltage between test point VDD2 and GND is 2.5V ± 0.1V.	IC1, Q3, C4, C5				
(D)*	BBIC Confirmation	-	1. BBIC Confirmation (Execute the command "getchk"). 2. Confirm the returned checksum value. Connection of checksum value and program number is shown below. ex.) <table border="1" style="display: inline-table; vertical-align: middle;"> <tr> <td>checksum value</td> <td>program number</td> </tr> <tr> <td>5D9E</td> <td>D872ZA</td> </tr> </table>	checksum value	program number	5D9E	D872ZA	IC1, X1, C6, C7, R19
checksum value	program number							
5D9E	D872ZA							
(E)*	EEP-ROM Confirmation	-	1. EEP-ROM Confirmation (Execute the command "ChkTGA710XXrevYY"). XX: country code YY: revision number 2. Confirm the returned checksum value. Note: "XX", "YY", and "checksum" vary depending on the country version. You can find them in the batch file, PQZZ- mentioned in JIG and PC (P.51).	IC1, IC3, R40, R41, R42, Q10, Q11, R43, R44, C37				
(F)	Charge Control Check & Charge Current Monitor Check	-	1. Apply 3.5V between J3(+) and J4(-) with DC power supply and set current limit to 250mA. 2. Confirm that the current limit LED of DC power supply is ON/OFF. 3. Decrease current limit of DC power supply to 100mA. 4. Confirm that the current limit LED of DC power supply is stable. (Current limiter is ON.) (If charge control cannot be confirmed by this procedure, please use battery to handset power supply and try again.)	IC1, Q4, Q5, Q9, D6, D7, D8, L4, L5, R5, R6, R7, R8, F1				

	Items	Check Point	Procedure	Check or Replace Parts
(G)*	Charge Detection (OFF) Check	-	<ol style="list-style-type: none"> 1. Stop supplying 3.5V to J3 CHARGE(+) and J4 CHARGE(-). 2. Execute the command "Backloff" then "charge". 3. Confirm that the returned value is 00 (hex). 	IC1, Q4, Q5, Q9, D6, D7, D8, L4, L5, R5, R6, R7, R8, F1
(H)*	Battery Monitor Check	-	<ol style="list-style-type: none"> 1. Apply 2.25V between BATT and GND. 2. Execute the command "readbatt". It assumes that the return value is XX. a) $1E \leq XX \leq 2C$: No need to adjust b) XX: 18 ~ 1D: Need to adjust XX: 2D ~ 32: Need to adjust Write AD value of 2.25V to EEPROM. ex) read data: XX = 1D, write data: YY = 1D read data: XX = 2D, write data: YY = 2D EEPROM = 0004(Low Voltage) write "YY" Execute the command "wreeprom 00 04 01 YY". EEPROM = 0005(No Voltage) write "YY - 1D" Execute the command "wreeprom 00 05 01 ZZ". EEPROM = 000A(Low Voltage BL) write "YY - 16" Execute the command "wreeprom 00 0A 01 WW". Note: ZZ = YY - 1D, WW = YY - 16 No Voltage writing data limit is '00'. c) XX: 00 ~ 17: Reject XX: 33 ~ FF: Reject 	IC1, F1, C1 C3, R12
(I)	Battery Low Confirmation	-	<ol style="list-style-type: none"> 1. Apply 2.40V between BATTERY(+) and BATTERY(-). 2. Confirm that there is no flashing of Battery Icon. 3. Apply 2.25V \pm 0.08V between BATTERY(+) and BATTERY(-). 4. Confirm that there is flashing of Battery Icon. 	IC1, F1, C1 C3, R12
(J)*	BBIC Clock Adjustment	CLK	<ol style="list-style-type: none"> 1. Apply 2.6V between BATTERY(+) and BATTERY(-) with DC power. 2. Execute the command "contx". 3. Input Command "rdeeprom 00 01 01", then you can confirm the current value. 4. Adjust the frequency of CLK executing the command "setfreq xx (where xx is the value)" so that the reading of the frequency counter is 10.368000MHz \pm 10Hz. <p>Note: CLK is displayed only for a few seconds when executing the command "contx" after battery is inserted.</p>	IC1, X1, C6, C7, R19, IC4, C57, R51
(K)*	Transmitted Power Confirmation	-	<p>Remove the Antenna before starting step from 1 to 4.</p> <ol style="list-style-type: none"> 1. Configure the DECT tester (CMD60) as follows; <Setting> • Test mode: PP • RFPI: 0102030405 • Traffic Carrier: 5 • Traffic Slot: 4 • Mode: Loopback • RF LEVEL = -70dBm 2. Execute the command "regcmd60 01 02 03 04 05". 3. Initiate connection from DECT tester. 4. Confirm that the NTP value at A201 is 19dBm ~ 25dBm. 	IC1, IC4, C66, C58, R51, C57, C50, C52, C53, R52, C60, C61
(L)*	Modulation Check and Adjustment	-	<p>Follow steps 1 to 3 of (K) above.</p> <ol style="list-style-type: none"> 4. Confirm that the B-Field Modulation is -350 ~ -400/+320 ~ +370kHz/div using data type Fig 31. 5. Adjust the B-Field Modulation if required. (Execute the command "Readmod" and "wrtmod xx", where xx is the value.) 	IC1, IC4, C66, C58, R51, C57, C50, C52, C53, R52, C60, C61
(M)	Frequency Offset Confirmation	-	<p>Follow steps 1 to 3 of (K) above.</p> <ol style="list-style-type: none"> 4. Confirm that the frequency Offset is $< \pm 45$kHz. 	IC1, IC4, C66, C58, R51, C57, C50, C52, C53, R52, C60, C61
(N)	Frequency Drift Confirmation	-	<p>Follow steps 1 to 3 of (K).</p> <ol style="list-style-type: none"> 4. Confirm that the frequency Drift is $< \pm 30$kHz/ms. 	IC1, IC4, C66, C58, R51, C57, C50, C52, C53, R52, C60, C61

	Items	Check Point	Procedure	Check or Replace Parts
(O)	Sensitivity Receiver Confirmation	-	Follow steps 1 to 3 of (K). 4.Set DECT tester power to -88dBm. 5.Confirm that the BER is < 1000ppm.	IC1, IC4, C66, C58, R51, C57, C50, C52, C53, R52, C60, C61
(P)	Timing Confirmation	-	Follow steps 1 to 3 of (K). 4.Confirm that the Timing accuracy is < ± 2.0ppm.	IC1, IC4, C66, C58, R51, C57, C50, C52, C53, R52, C60, C61
(Q)*	RSSI Level Confirmation	-	Follow steps 1 to 3 of (K). 4.Set DECT tester power to -81dBm. 5.Execute the command "readrssi". 6.Confirm that the returned value is 1C ± 8 (hex). 7.Set DECT tester power to -63dBm. 8.Execute the command "readrssi". 9.Confirm that the returned value is 25 ± 8 (hex).	IC1, IC4, C66, C58, R51, C57, C50, C52, C53, R52, C60, C61
(R)	Power RAMP Confirmation	-	Follow steps 1 to 3 of (K). 4.Confirm that Power RAMP is matching.	IC1, IC4, C66, C58, R51, C57, C50, C52, C53, R52, C60, C61
(S)	Audio Check and Confirmation	-	1. Link to BASE which is connected to Line Simulator. 2. Set line voltage to 48V and line current to 40mA. 3. Input -45dBm/1KHz to MIC and measure Line output level. 4. Confirm that the level is -8dBm ± 2dBm and that the distortion level is < 5% at TEL Line (600Ω Load). 5. Input -20dBm/1KHz to Line I/F and measure Receiving level at REV1 and REV2. 6. Confirm that the level is -21dBm ± 2dBm and that the distortion level is < 5% at Receiver. (vol = 2)	IC1, R21, R22, R23, R24, R25, C11, C70, C71, D4, D5
(T)	SP phone Audio Check and Confirmation	-	1. Link to Base which is connected to Line Simulator. 2. Set line voltage to 48V and line current to 40mA. 3. Set the handset off-hook using SP-Phone key. 4. Input -25dBm/1KHz to Line I/F and measure Receiving level at SP_TEST1 and SP_TEST2. 5. Confirm that the level is -14dBm ± 2dBm and that the distortion level is < 5%. (vol = 3)	IC1, R21, R22, R23, R24, R25, C11, R103, R104, C98, C99, C39

9.3.2. Troubleshooting for Speakerphone

When the customer's telephone line corresponds to the following conditions, and the transmission signal of SP-Phone is interrupted, performing the next set up to a cordless handset will improve it to some extent.

Conditions

- When customer's line has less line loss.
ex.) The customer is using optical fiber, ISDN terminal adaptor, or PBX.
In this case, receiving signal is strong and it may affect transmission signal.
- When the other party is talking from noisy place.
ex.) The other party is using cellular phone. The background noise is very loud.
In this case, the noise from the other party (i.e. surrounding noise) may affect transmission signal.

Setting Method

- Change the address of EEPROM (0144) from 00 to 01.

9.4. How to Replace the Flat Package IC

Even if you do not have the special tools (for example, a spot heater) to remove the Flat IC, with some solder (large amount), a soldering iron and a cutter knife, you can easily remove the ICs that have more than 100 pins.

9.4.1. Preparation

- PbF (: Pb free) Solder

- Soldering Iron

Tip Temperature of 700 °F ± 20 °F (370 °C ± 10 °C)

Note: We recommend a 30 to 40 Watt soldering iron. An expert may be able to use a 60 to 80 Watt iron where someone with less experience could overheat and damage the PCB foil.

- Flux

Recommended Flux: Specific Gravity → 0.82.

Type → RMA (lower residue, non-cleaning type)

Note: See **About Lead Free Solder (Pbf: Pb free)** (P.4)

9.4.2. How to Remove the IC

1. Put plenty of solder on the IC pins so that the pins can be completely covered.

Note:

If the IC pins are not soldered enough, you may give pressure to the P.C. board when cutting the pins with a cutter.

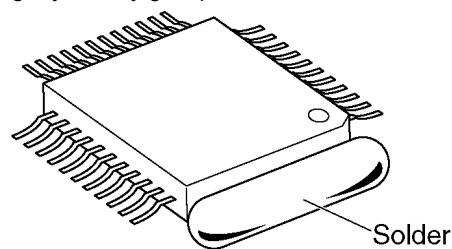

2. Make a few cuts into the joint (between the IC and its pins) first and then cut off the pins thoroughly.

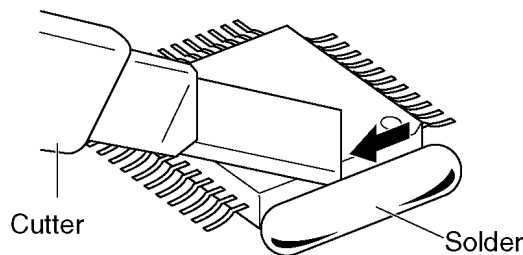

3. While the solder melts, remove it together with the IC pins.

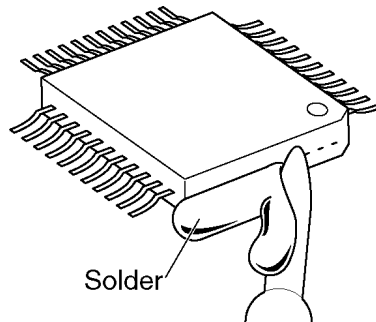

When you attach a new IC to the board, remove all solder left on the land with some tools like a soldering wire. If some solder is left at the joint on the board, the new IC will not be attached properly.

9.4.3. How to Install the IC

1. Temporarily fix the FLAT PACKAGE IC, soldering the two marked pins.

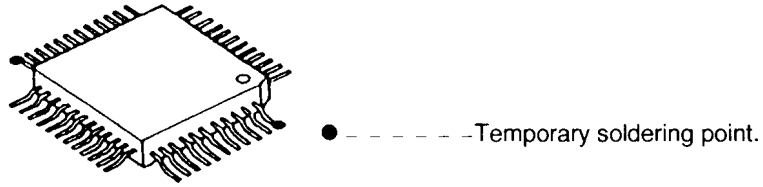

*Check the accuracy of the IC setting with the corresponding soldering foil.

2. Apply flux to all pins of the FLAT PACKAGE IC.

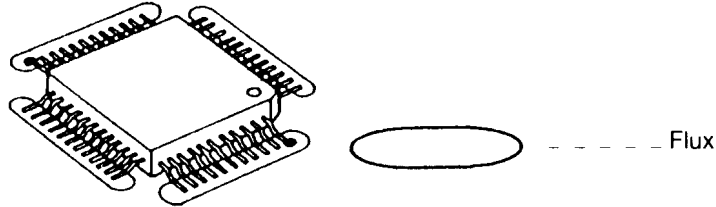

3. Solder the pins, sliding the soldering iron in the direction of the arrow.

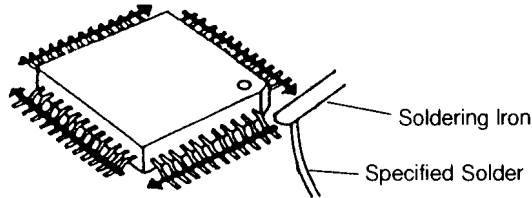

9.4.4. How to Remove a Solder Bridge

1. Lightly resolder the bridged portion.
2. Remove the remaining solder along the pins using a soldering iron as shown in the figure below.

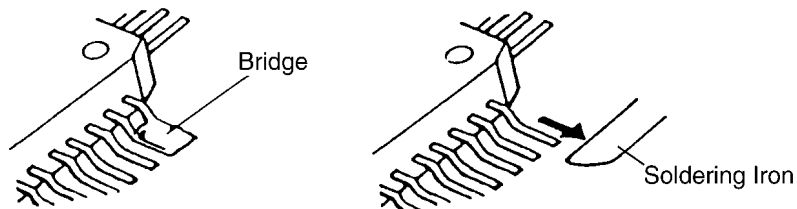

10 Disassembly and Assembly Instructions

10.1. Disassembly Instructions

10.1.1. Base Unit

- ① Remove the 4 screws to remove the Cabinet Cover.

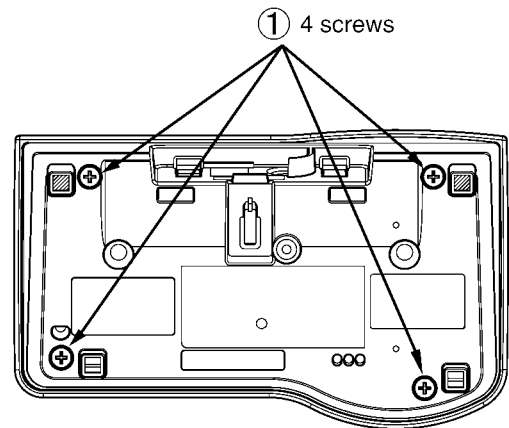

- ② Remove the Solders to remove the Main P.C. Board.

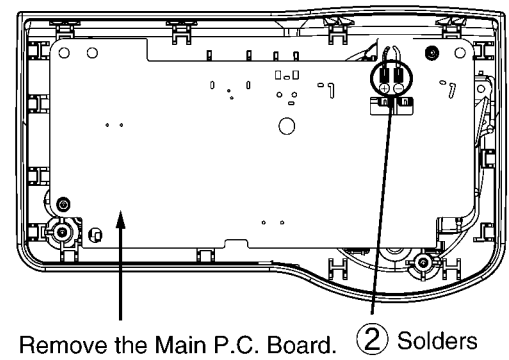

10.1.2. Handset

- ① Remove the 2 screws.

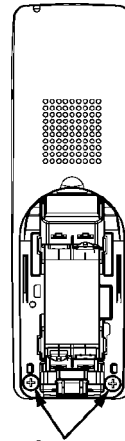

- ② Insert a JIG (PQDJ10006Y) between the Cabinet Body and the Cabinet Cover, then pull it along the gap to open the Cabinet.

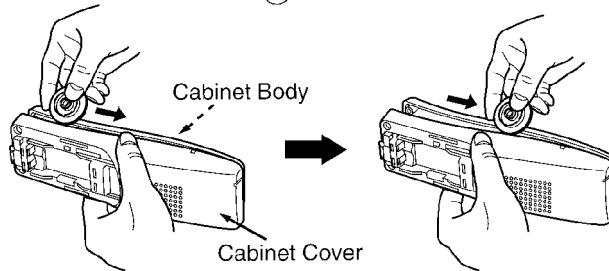

- ③ Likewise, open the other side of the Cabinet.

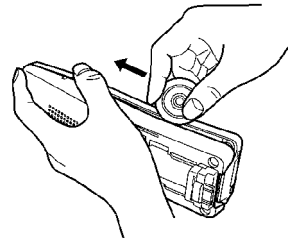

- ④ Remove the Cabinet Cover by pushing it upward.

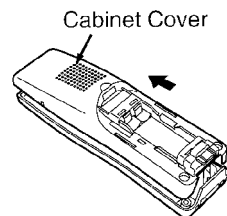

Remove the Main P. C. Board.

- ⑤ Remove the Tape and the Solders.

- ⑥ Remove the 2 screws to remove the 2 Charge Terminals.

- ⑦ Remove the screw to remove the Main P. C. Board.

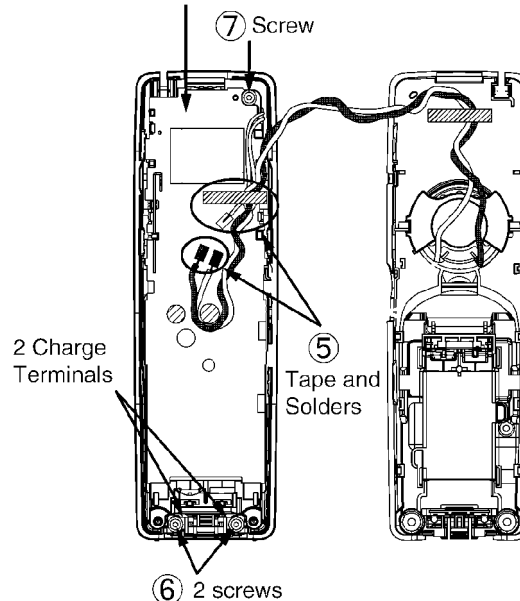

10.1.3. Charger Unit

- ① Remove the screw to remove the Cabinet Cover.

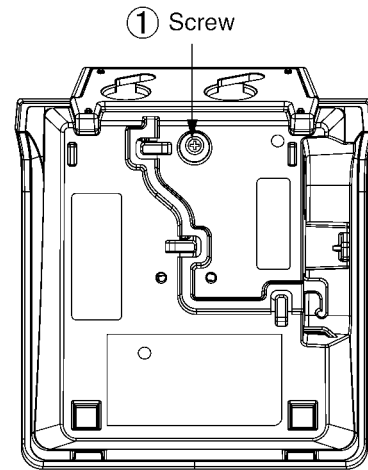

- ② Remove the Solders to remove the Main P. C. Board.

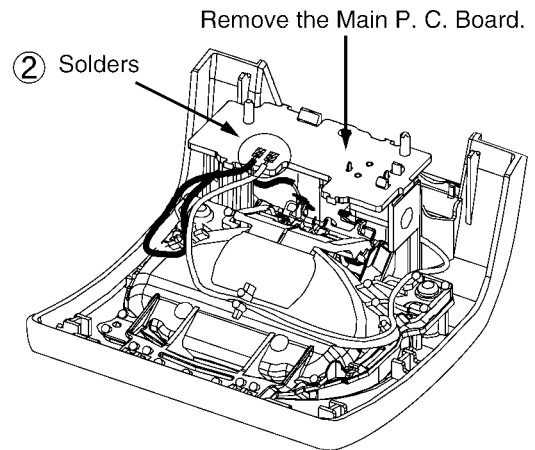

10.2. How to Replace the Handset LCD

①

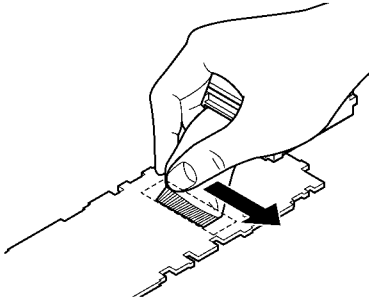

Peel off the FFC (Flexible Flat Cable) of LCD in the direction of the arrow not to damage the foil on the P.C. Board.

②

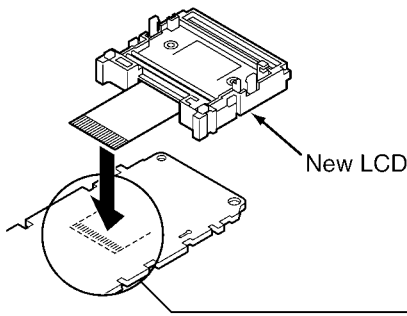

Fit the Heatseal of a New LCD to the P.C. Board.

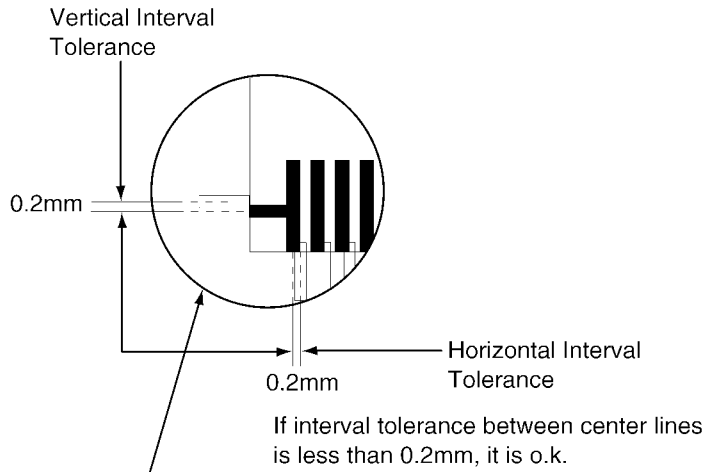

OK

③

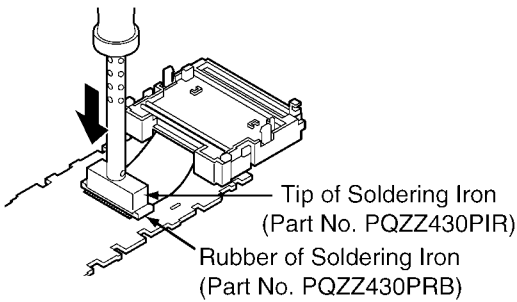

Heatweld with the Tip of Soldering Iron about 5 to 8 seconds (in case of 60W soldering iron).

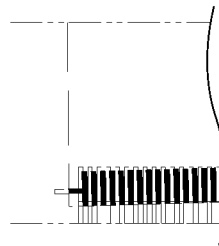

NG

(Inclined)

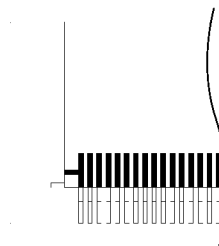

NG

(Vertical interval tolerance is more than 0.2mm.)

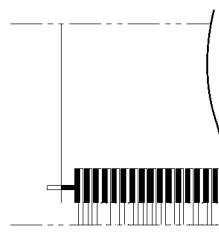

NG

(Horizontal interval tolerance is more than 0.2mm.)

11 Measurements and Adjustments

11.1. The Setting Method of JIG (Base Unit)

11.1.1. Preparation

11.1.1.1. Equipment Required

- DECT tester: Rohde & Schwarz, CMD 60 is recommended.
- Frequency counter: it must be precise to be able to measure 1 Hz (precision; ± 4 ppm).
Hewlett Packard, 53131A is recommended.
- Digital multi-meter (DMM): it must be able to measure voltage and current.
- Oscilloscope

11.1.1.2. JIG and PC

- EEPROM serial JIG
JIG Cable: PQZZ1CD300E*
- PC which runs in DOS mode
- **Batch file CD-ROM** for setting: PQZZTG7100E

Note:

*: If you have the JIG Cable for TCD500 series (PQZZ1CD505E), change the following values of resistance. Then you can use it as a JIG Cable for both TCD300 and TCD500 series. (It is an upper compatible JIG Cable.)

Resistor	Old value (k Ω)	New value (k Ω)
R2	22	3.3
R3	22	3.3
R4	22	4.7
R7	4.7	10

11.1.2. PC Setting

11.1.2.1. Connections

- ① Connect the AC adaptor to CN2 (base unit).
- ② Connect the JIG Cable GND (black).
- ③ Connect the JIG Cable RX (red) and TX (yellow).

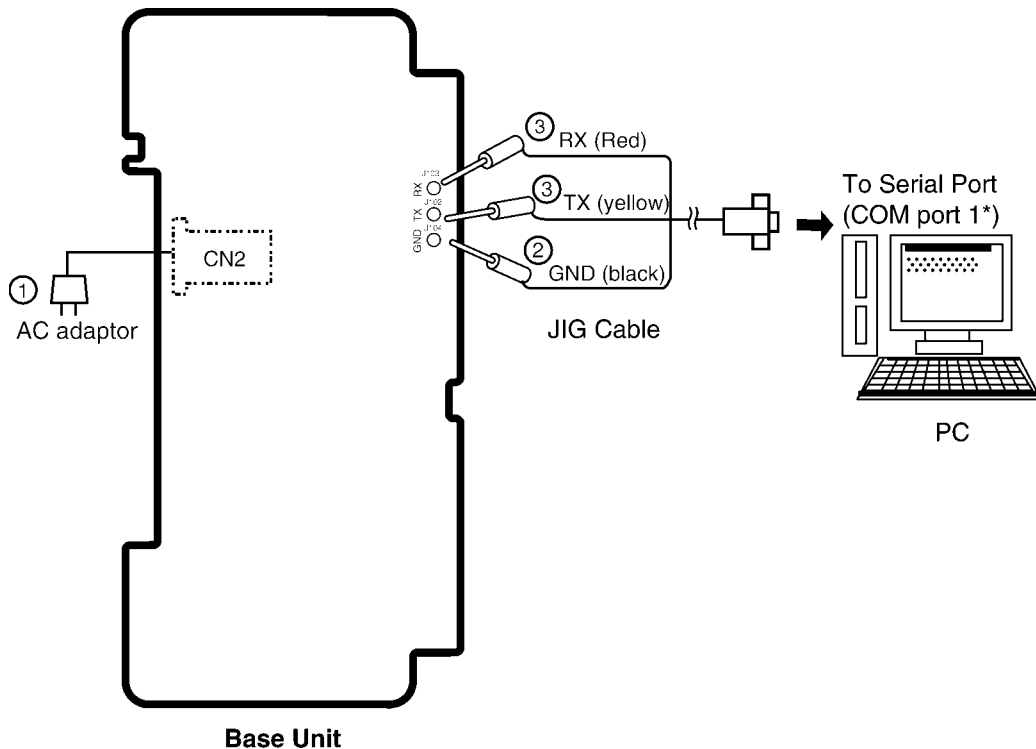

Note:

*: COM port names may vary depending on what your PC calls it.

11.1.2.2. PC Setting

1. Insert the Batch file CD-ROM into CD-ROM drive and copy PQQZTG**** folder to your PC (example: D drive).

2. Open a window of MS-DOS mode.

<Example for Windows>

On your computer, click [Start], select **Programs** (**All Programs** for Windows XP/Windows Server 2003), then click
MS-DOS Prompt. (for Windows 95/Windows 98)
 Or
Accessories-MS-DOS Prompt. (for Windows Me)
 Or
Command Prompt. (for Windows NT 4.0)
 Or
Accessories-Command Prompt. (for Windows 2000/Windows XP/Windows Server 2003)

3. At the DOS prompt, type "D:" (for example) to select the drive, then press the **Enter** key.

4. Type "CD ¥PQQZTG****", then press the **Enter** key.

<Example: correct setting>

```
C: ¥Documents and Settings>D:
D: ¥>CD ¥PQQZTG****
D: ¥PQQZTG**** >SET_COM=X
D: ¥PQQZTG****>READID
00 52 4F A8 A8
D: ¥PQQZTG****>DOSKEY
D: ¥PQQZTG****>_
```

5. Type "SET_COM=X", then press the **Enter** key (X: COM port number used for the serial connection on your PC).

6. Type "READID", then press the **Enter** key.
 • If any error messages appear, change the port number or check the cable connection.
 • If any value appear, go to next step.

<Example: incorrect setting>

```
C: ¥Documents and Settings>D:
D: ¥>CD ¥PQQZTG****
D: ¥PQQZTG**** >SET_COM=X
D: ¥PQQZTG****>READID
CreateFile error
ERROR 10: Can't open serial port
D: ¥PQQZTG ****>_
```

7. Type "DOSKEY", then press the **Enter** key.

Note:

- "****" varies depending on the country.
- See the table below for frequently used commands.

Command name	Function	Example
rdeeprom	Read the data of EEPROM	Type "rdeeprom 00 00 FF", and the data from address "00 00" to "FF" is read out.
readid	Read ID (RFPI)	Type "readid", and the registered ID is read out.
writeid	Write ID (RFPI)	Type "writeid 00 18 E0 0E 98", and the ID "0018 E0 0E 98" is written.
setfreq	Adjust Frequency of RFIC	Type "setfreq nn".
hookoff	Off-hook mode on Base	Type "hookoff".
hookon	On-hook mode on Base	Type "hookon".
getchk	Read checksum	Type "getchk".
wreeprom	Write the data of EEPROM	Type "wreeprom 01 23 45". "01 23" is address and "45" is data to be written.

11.2. Adjustment Standard (Base Unit)

When connecting the Simulator Equipments for checking, please refer to below.

11.2.1. Flow Solder Side View

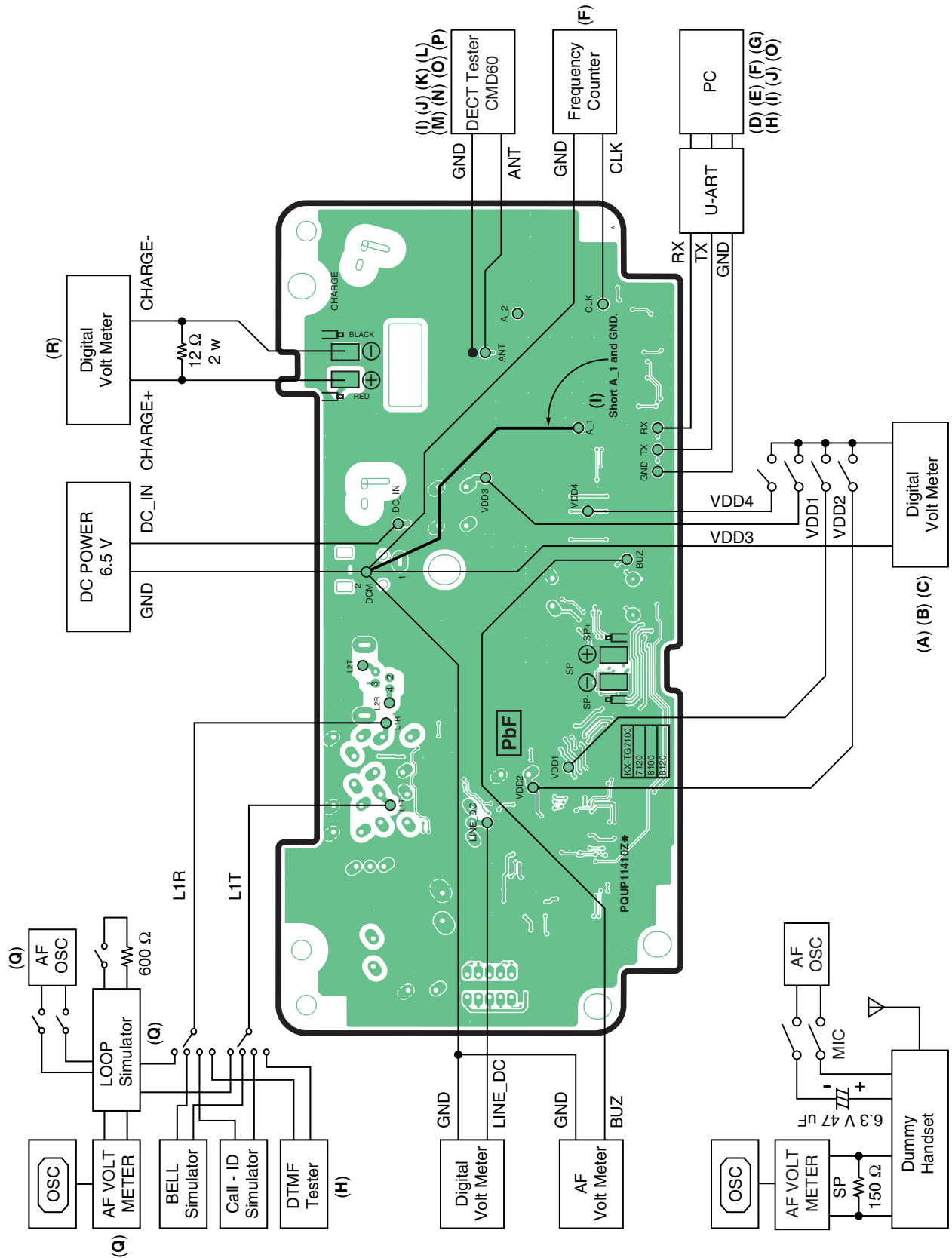

Note:

(A) - (R) is referred to **Check Point (Base Unit)** (P.34)

11.3. Adjustment Standard (Charger Unit)

When connecting the Simulator Equipments for checking, please refer to below.

11.3.1. Flow Solder Side View

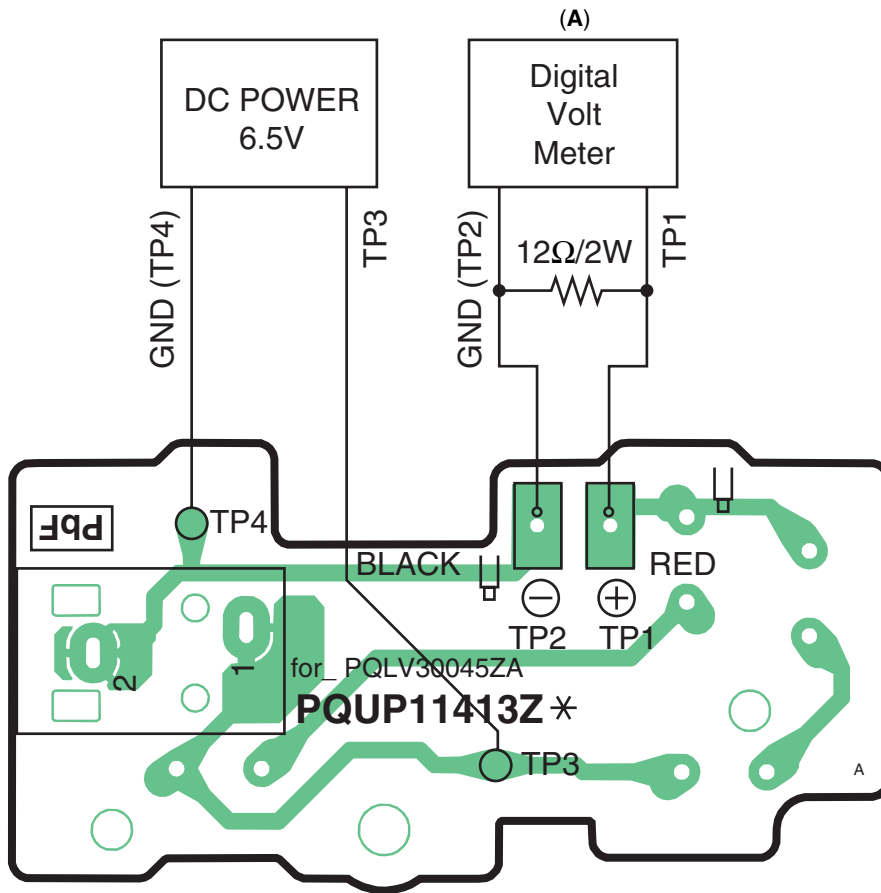

Note:
 (A) is referred to Check Point (Charger Unit) (P.37)

11.4. The Setting Method of JIG (Handset)

11.4.1. Preparation

11.4.1.1. Equipment Required

- DECT tester: Rohde & Schwarz, CMD 60 is recommended.
- Frequency counter: it must be precise to be able to measure 1 Hz (precision; ± 4 ppm). Hewlett Packard, 53131A is recommended.
- DC power: it must be able to output at least 1 A current under 2.4 V for Handset.
- Digital multi-meter (DMM): it must be able to measure voltage and current.
- Oscilloscope

11.4.1.2. JIG and PC

- EEPROM serial JIG
JIG Cable: PQZZ1CD300E*
- PC which runs in DOS mode.
- **Batch file CD-ROM** for setting: PQZZTG7100E

Note:

*: If you have the JIG Cable for TCD500 series (PQZZ1CD505E), change the following values of resistance. Then you can use it as a JIG Cable for both TCD300 and TCD500 series. (It is an upper compatible JIG Cable.)

Resistor	Old value (k Ω)	New value (k Ω)
R2	22	3.3
R3	22	3.3
R4	22	4.7
R7	4.7	10

11.4.2. PC Setting

11.4.2.1. Connections

- ① Connect the DC Power or Battery to J1 and J2 (Handset).
- ② Connect the JIG cable GND (black).
- ③ Connect the JIG cable UTX (yellow) and URX (red).

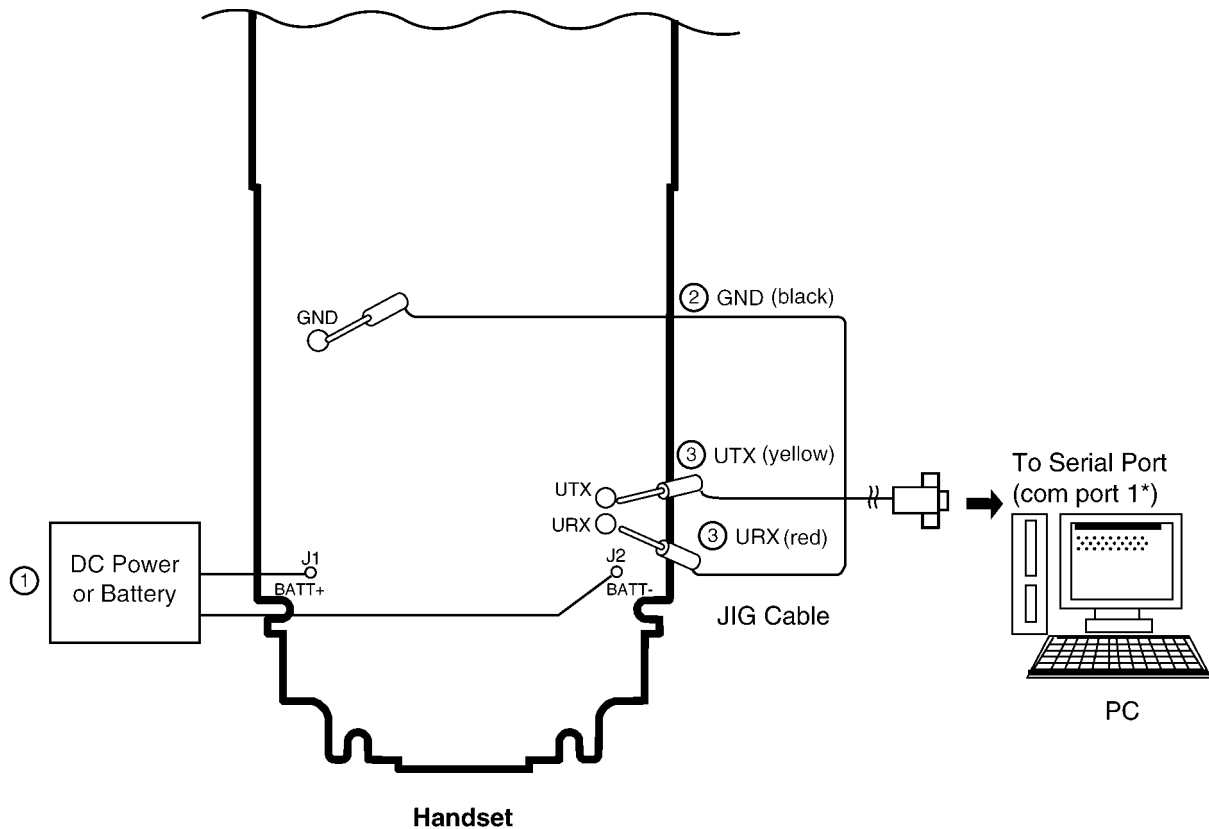

Note:

*: Com port names may vary depending on what your PC calls it.

11.4.2.2. PC Setting

1. Insert the Batch file CD-ROM into CD-ROM drive and copy PZZTG***** folder to your PC (example: D drive).

2. Open a window of MS-DOS mode.

<Example for Windows>

On your computer, click **[Start]**, select **Programs** (**All Programs** for Windows XP/Windows Server 2003), then click
MS-DOS Prompt. (for Windows 95/Windows 98)
 Or
Accessories-MS-DOS Prompt. (for Windows Me)
 Or
Command Prompt. (for Windows NT 4.0)
 Or
Accessories-Command Prompt. (for Windows 2000/Windows XP/Windows Server 2003)

3. At the DOS prompt, type "D:" (for example) to select the drive, then press the **Enter** key.

4. Type "CD ¥PZZTG*****", then press the **Enter** key.

<Example: correct setting>

```
C: ¥Documents and Settings>D:
D: ¥>CD ¥PZZTG*****
D: ¥PZZTG***** >SET RTX_COM=X
D: ¥PZZTG*****>READID
00 52 4F A8 A8
D: ¥PZZTG*****>DOSKEY
D: ¥PZZTG*****> _
```

5. Type "SET RTX_COM=X", then press the **Enter** key (X: COM port number used for the serial connection on your PC).

6. Type "READID", then press the **Enter** key.
 •If any error messages appear, change the port number or check the cable connection.
 •If any value appear, go to next step.

<Example: incorrect setting>

```
C: ¥Documents and Settings>D:
D: ¥>CD ¥PZZTG*****
D: ¥PZZTG***** >SET RTX_COM=X
D: ¥PZZTG*****>READID
CreateFile error
ERROR 10: Can't open serial port
D: ¥PZZTG*****> _
```

7. Type "DOSKEY", then press the **Enter** key.

Note:

- "*****" varies depending on the country.
- See the table below for frequently used commands.

Command name	Function	Example
rdeeprom	Read the data of EEPROM	Type "rdeeprom 00 00 FF", and the data from address "00 00" to "FF" is read out.
readid	Read ID (RFPI)	Type "readid", and the registered ID is read out.
writeid	Write ID (RFPI)	Type "writeid 00 18 E0 0E 98", and the ID "0018 E0 0E 98" is written.
setfreq	Adjust Frequency of RFIC	Type "setfreq nn".
getchk	Read checksum	Type "getchk".
wreeprom	Write the data of EEPROM	Type "wreeprom 01 23 45". "01 23" is address and "45" is data to be written.

11.6. Things to Do after Replacing IC

Cautions:

Since this page is common to each country, it may not apply to some models in your country. The contents below are the minimum adjustments required for operation.

11.6.1. Base Unit

Before doing the following adjustment, be sure to do **PC Setting (P.47)** in **The Setting Method of JIG (Base Unit)**.

IC		Necessary Adjustment
BBIC (IC7)	Programs for Voice processing, interface for RF and EEPROM	<ol style="list-style-type: none"> 1. Default batch file: Execute the command "default.bat". 2. Country version batch file: Execute the command "TG7100XXrevYY.bat". (*1) 3. Clock adjustment: Refer to Check Point (F). (*2)
EEPROM (IC5)	Adjustment parameter data (country version batch file, default batch file, etc.)	<ol style="list-style-type: none"> 1. Change the address "0000" of EEPROM to "00". 2. Default batch file: Execute the command "default.bat". 3. Country version batch file: Execute the command "TG7100XXrevYY.bat". (*1) 4. Clock adjustment: Refer to Check Point (F). (*2)

Note:

(*1) XX: country code, YY: revision number

"XX" and "YY" vary depending on the country version. You can find them in the batch file, PQZZ- mentioned in **JIG and PC (P.47)**.

(*2) Refer to **Check Point (Base Unit) (P.34)**

11.6.2. Handset

Before doing the following adjustment, be sure to do **PC Setting (P.48)** in **The Setting Method of JIG (Handset)**.

IC		Necessary Adjustment
BBIC (IC1)	Programs for Voice processing, interface for RF and EEPROM	<ol style="list-style-type: none"> 1. Default batch file: Execute the command "default.bat". 2. Default batch file (remaining); Execute the command "TGA710 DEFrevYY.bat". (*3) 3. Country version batch file: Execute the command "TGA710XXrevYY". (*3) 4. Clock adjustment: Refer to Check Point (J). (*4) 5. 1.8 V setting and battery low detection: Refer to Check Point (A), (H) and (I). (*4)
EEPROM (IC3)	Adjustment parameter data (country version batch file, default batch file, etc.)	<ol style="list-style-type: none"> 1. Change the address "0015" of EEPROM to "00". 2. Default batch file: Execute the command "default.bat". 3. Default batch file (remaining); Execute the command "TGA710 DEFrevYY.bat". (*3) 4. Country version batch file: Execute the command "TGA710XXrevYY". (*3) 5. Clock adjustment: Refer to Check Point (J). (*4) 6. 1.8 V setting and battery low detection: Refer to Check Point (A), (H) and (I). (*4)

Note:

(*3) XX: country code, YY: revision number

"XX" and "YY" vary depending on the country version. You can find them in the batch file, PQZZ- mentioned in **JIG and PC (P.47)**.

(*4) Refer to **Check Point (Handset) (P.38)**

11.7. RF Specification

11.7.1. Base Unit

Item	Value	Refer to -. *
TX Power	20 dBm ~ 25 dBm	Check Point (Base Unit) (I)
Modulation	-350 ~ -400/+320 ~ +370 kHz/div	Check Point (Base Unit) (J)
Frequency Offset	-45 kHz ~ +45 kHz	Check Point (Base Unit) (K)
Frequency Drift	< ± 30 kHz / ms	Check Point (Base Unit) (L)
RX Sensitivity	< 1000 ppm	Check Point (Base Unit) (M)
Timing Accuracy	< ± 2.0 ppm	Check Point (Base Unit) (N)
RSSI Level	22 hex ± A hex	Check Point (Base Unit) (O)
Power RAMP	Power RAMP is matching	Check Point (Base Unit) (P)

*: Refer to **Check Point (Base Unit) (P.34)**

11.7.2. Handset

Item	Value	Refer to -. **
TX Power	19 dBm ~ 25 dBm	Check Point (Handset) (K)
Modulation	-350 ~ -400/+320 ~ +370 kHz/div	Check Point (Handset) (L)
Frequency Offset	-45 kHz ~ +45 kHz	Check Point (Handset) (M)
Frequency Drift	< ± 30 kHz / ms	Check Point (Handset) (N)
RX Sensitivity	< 1000 ppm	Check Point (Handset) (O)
Timing Accuracy	< ± 2.0 ppm	Check Point (Handset) (P)
RSSI Level	1C hex ± 8 hex (at -81dBm) 25 hex ± 8 hex (at -63dBm)	Check Point (Handset) (Q)
Power RAMP	Power RAMP is matching	Check Point (Handset) (R)

** : Refer to **Check Point (Handset) (P.38)**

11.8. How to Check the Handset Speaker of Receiver

1. Prepare the digital voltmeter, and set the selector knob to ohm meter.
2. Put the probes at the speaker terminals as shown below.

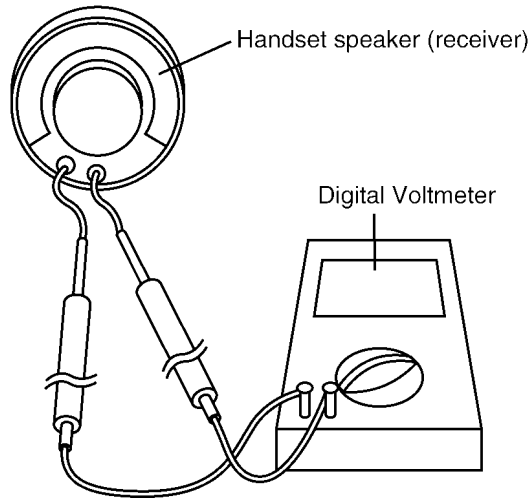
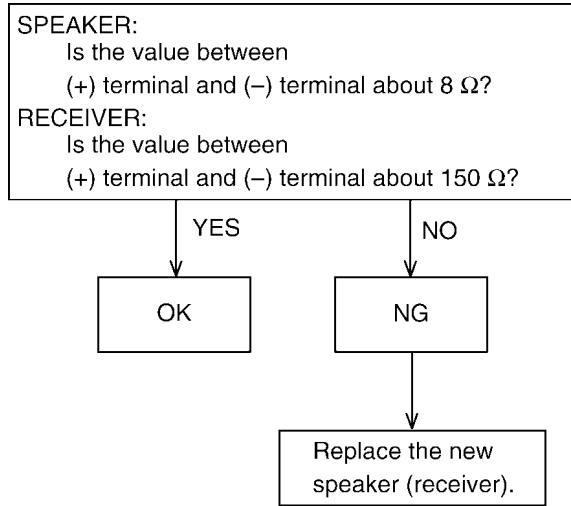

11.9. Frequency Table (MHz)

Channel No	BASE UNIT		HANDSET	
	Transmit Frequency	Receive Frequency	Transmit Frequency	Receive Frequency
1	1897.344	1897.344	1897.344	1897.344
2	1895.616	1895.616	1895.616	1895.616
3	1893.888	1893.888	1893.888	1893.888
4	1892.160	1892.160	1892.160	1892.160
5	1890.432	1890.432	1890.432	1890.432
6	1888.704	1888.704	1888.704	1888.704
7	1886.976	1886.976	1886.976	1886.976
8	1885.248	1885.248	1885.248	1885.248
9	1883.520	1883.520	1883.520	1883.520
10	1881.792	1881.792	1881.792	1881.792

Note:

Channel No. 10: In the Test Mode on Base Unit and Handset.

12 Schematic Diagram

12.1. For Schematic Diagram

12.1.1. Base Unit (Schematic Diagram (Base Unit))

Notes:

1. DC voltage measurements are taken with voltmeter from the negative voltage line.

Important Safety Notice:
Components identified by ⚠ mark have special characteristics important for safety. When replacing any of these components, use only the manufacturer's specified parts.

2. The schematic diagram may be modified at any time with the development of new technology.

12.1.2. Handset (Schematic Diagram (Handset))

Notes:

1. DC voltage measurements are taken with an oscilloscope or a tester with a ground.
2. The schematic diagram may be modified at any time with the development of new technology.

12.1.3. Charger Unit (Schematic Diagram (Charger Unit))

Notes:

1. DC voltage measurements are taken with voltmeter from the negative voltage line.

Important Safety Notice:
Components identified by ⚠ mark have special characteristics important for safety. When replacing any of these components, use only the manufacturer's specified parts.

2. The schematic diagram may be modified at any time with the development of new technology.

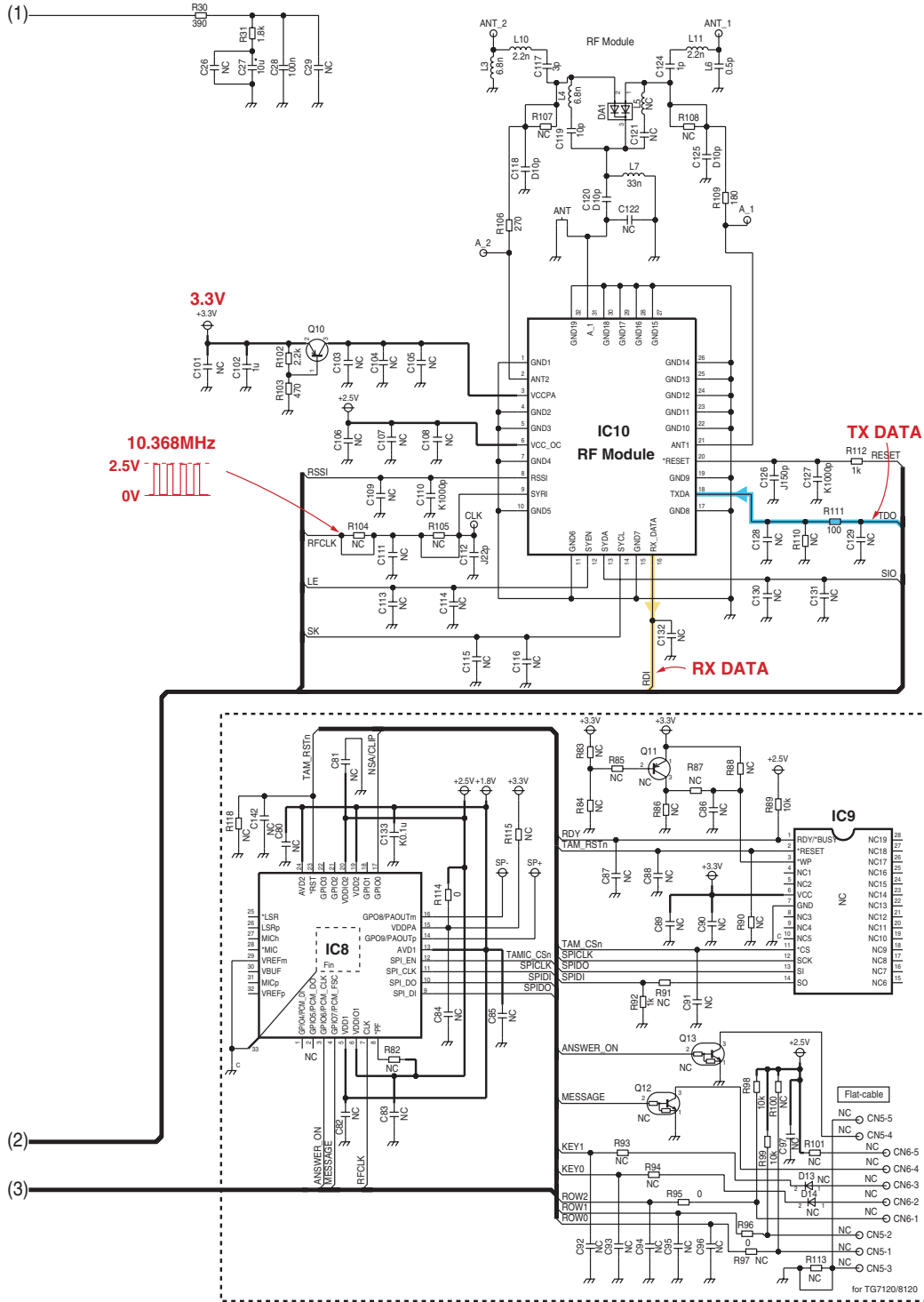

NC: No Components
KX-TG7100/7102/7103 SCHEMATIC DIAGRAM (Base Unit)

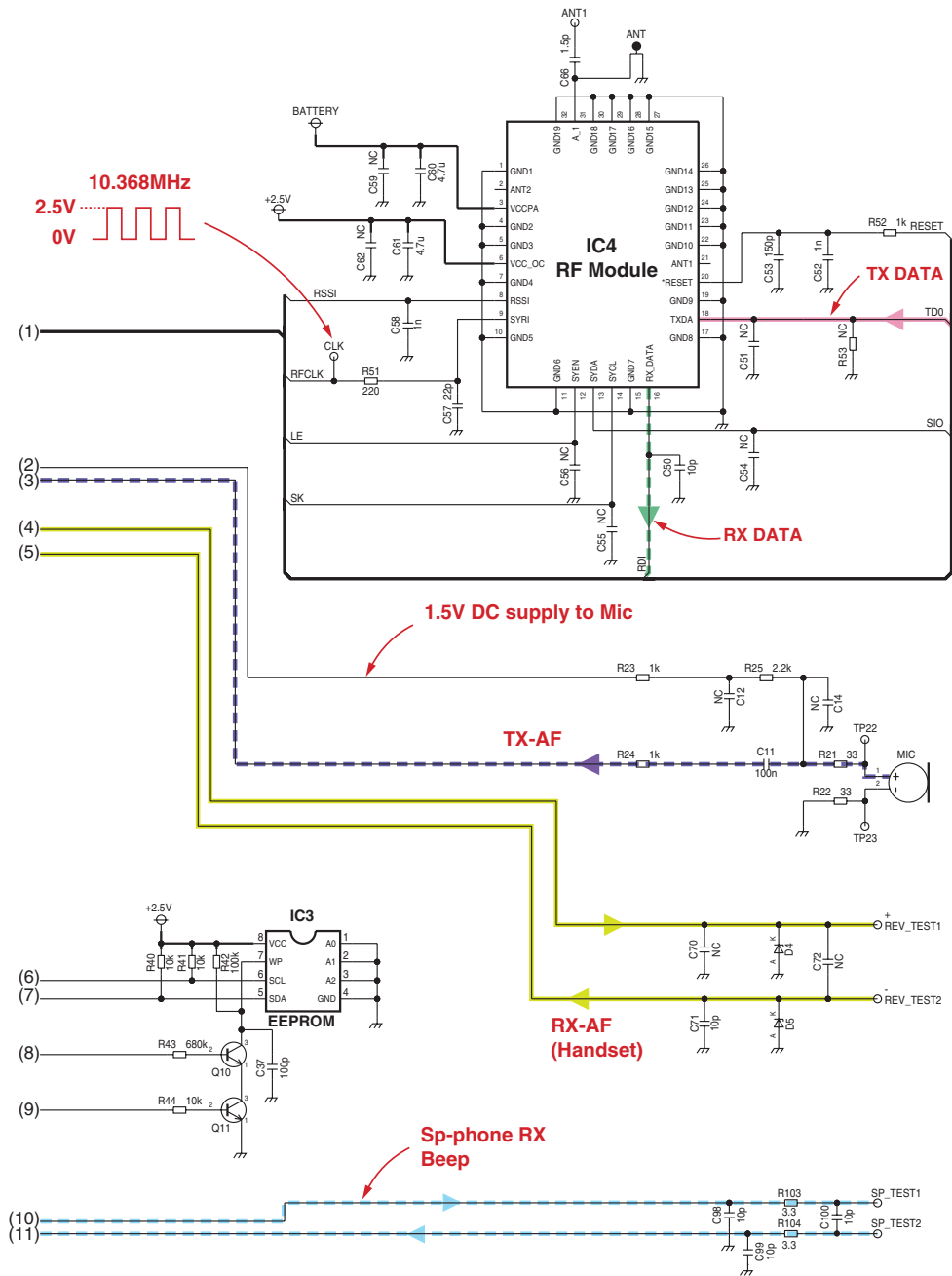

NC: No Components
KX-TGA710 SCHEMATIC DIAGRAM (Handset)

12.4. Schematic Diagram (Charger Unit)

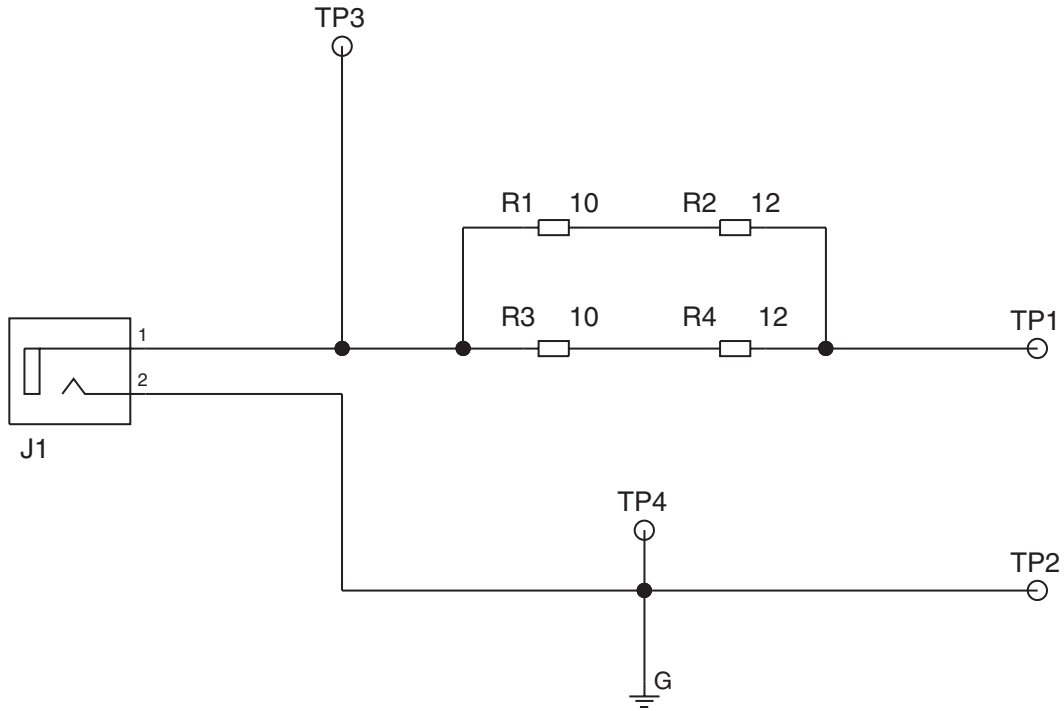

NC: No Components
SCHEMATIC DIAGRAM (Charger Unit)

13 Printed Circuit Board

13.1. Circuit Board (Base Unit)

13.1.1. Component View

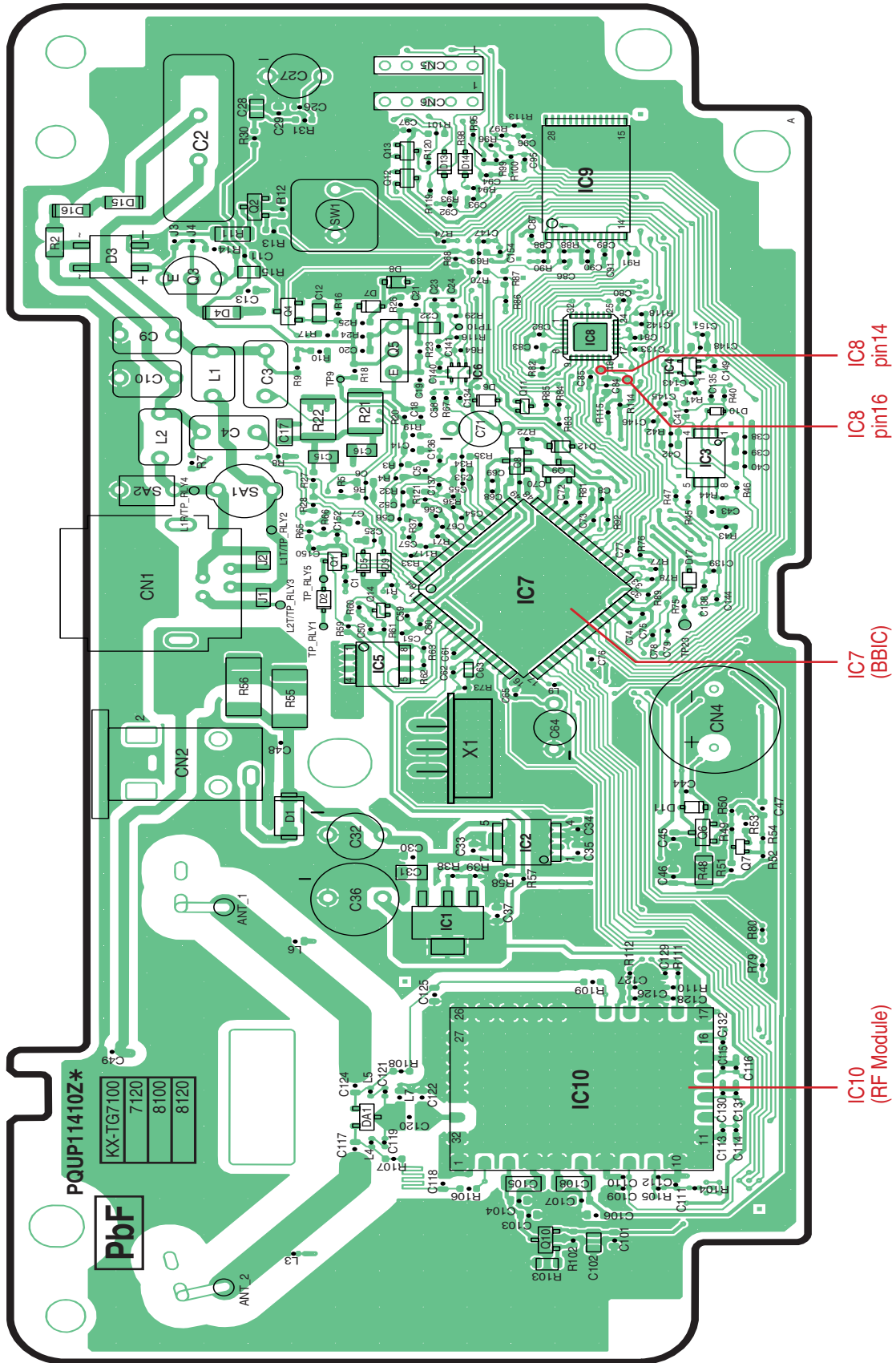

KX-TG7100/7102/7103 CIRCUIT BOARD (Base Unit (Component View))

13.1.2. Flow Solder Side View

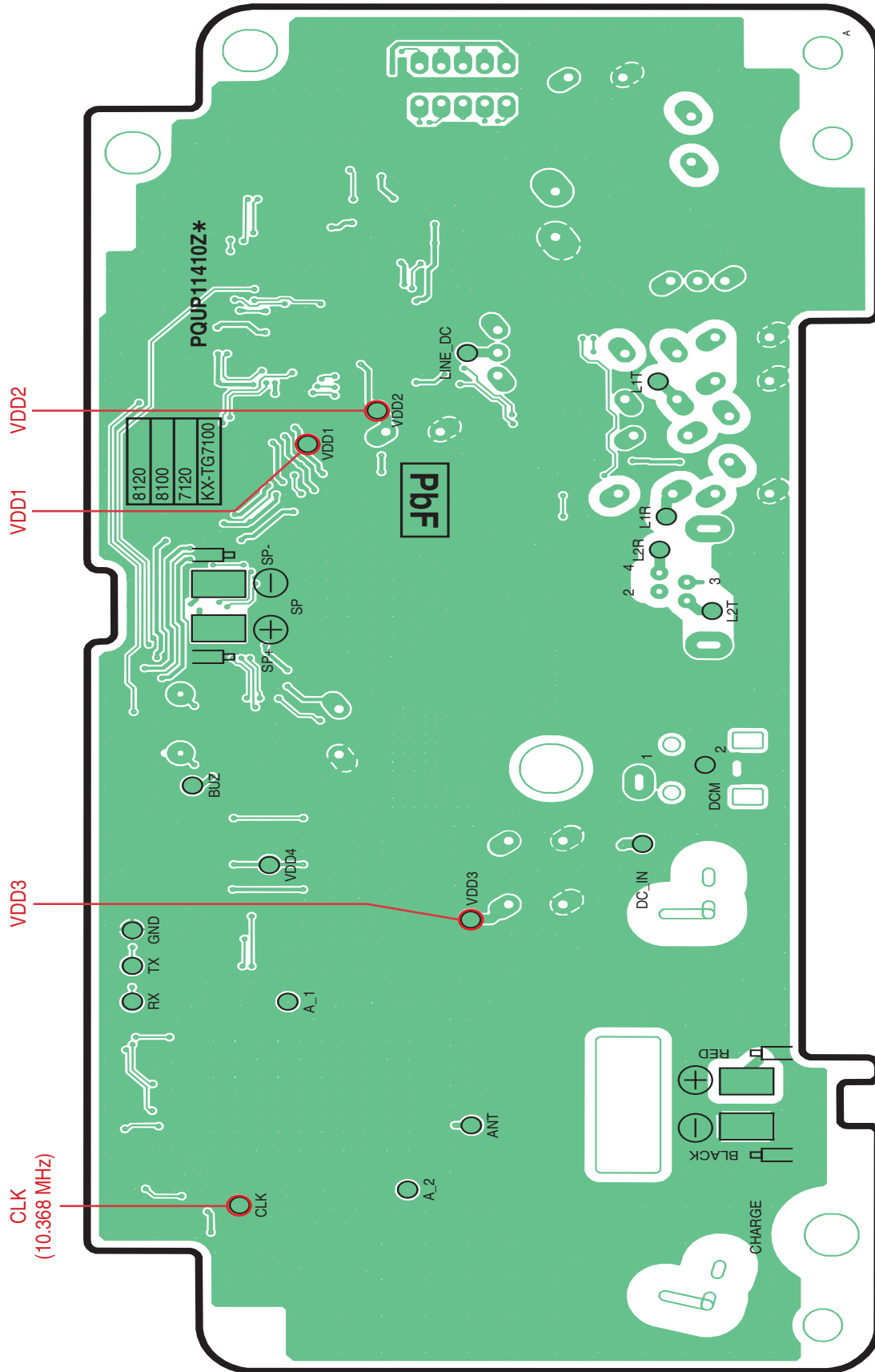

KX-TG7100/7102/7103 CIRCUIT BOARD (Base Unit (Flow Solder Side View))

13.2.2. Flow Solder Side View

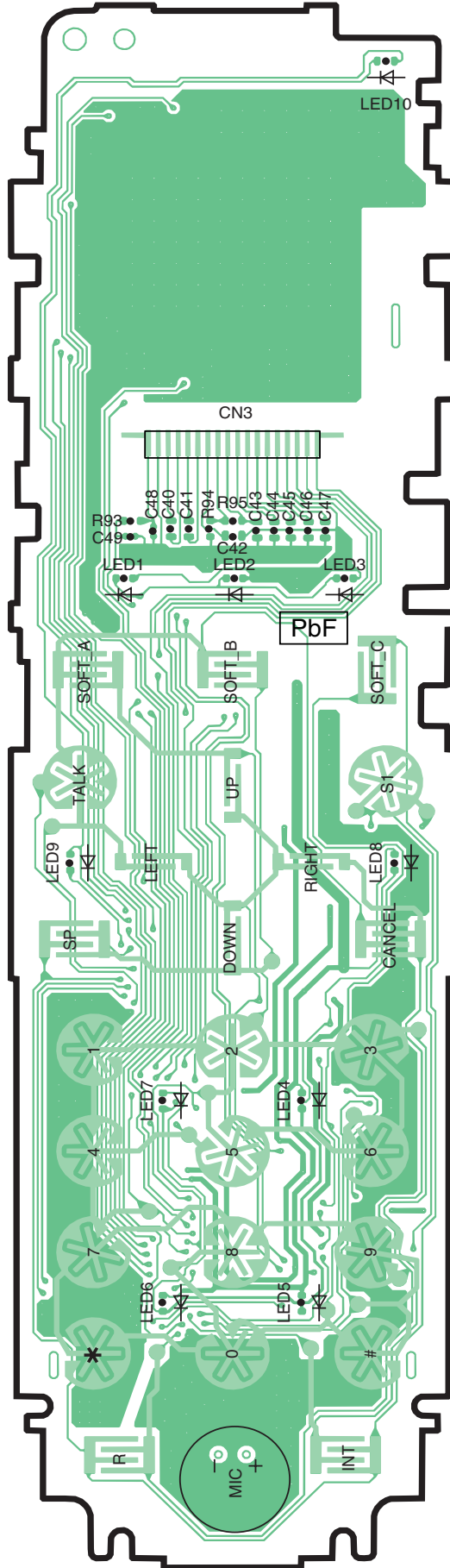

KX-TGA710 CIRCUIT BOARD (Handset (Flow Solder Side View))

13.3. Circuit Board (Charger Unit)

13.3.1. Component View

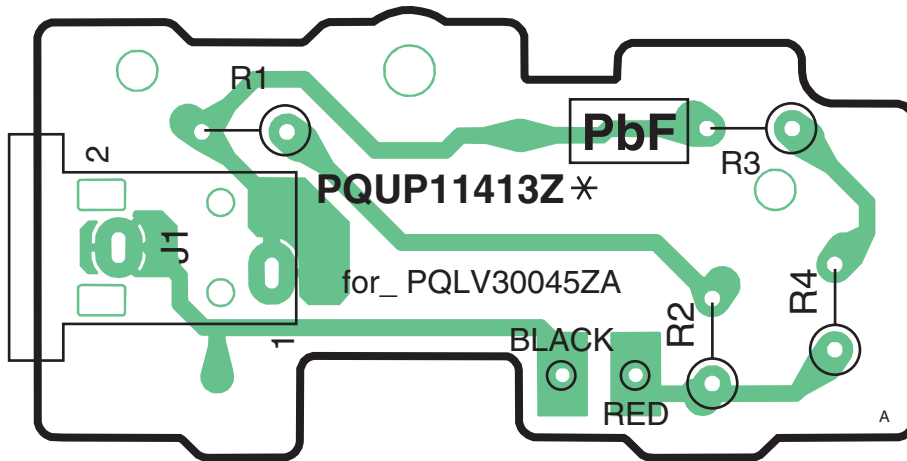

CIRCUIT BOARD (Charger Unit (Component View))

13.3.2. Flow Solder Side View

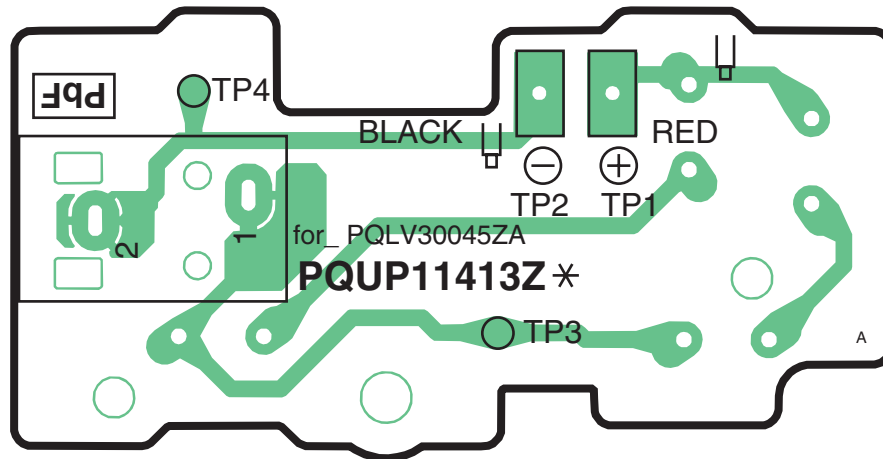

CIRCUIT BOARD (Charger Unit (Flow Solder Side View))

14 Appendix Information of Schematic Diagram

14.1. CPU Data (Base Unit)

14.1.1. IC7 (BBIC)

Pin No.	Description	I/O	Connection	at Normal mode	at Reset mode
1	*INT1n/ P11	D,O	RLY	O	I-PU
2	VDDIO1	-	-	-	-
3	VDD1	-	-	-	-
4	VSS1	-	-	-	-
5	SDA1/P25	D,I/O	SDA	I/O	I
6	SCL1/P24	D,O	SCL	O	I
7	*INT5/VDDE/P15	D,I	NC	I	I-PU
8	*INT2/P12	D,O	P1[2]	O-H	I-PU
9	AVD	-	-	-	-
10	AVS	-	-	-	-
11	CAP	A,I	CAP	I	I
12	Xtal1	A,I	Xtal1	I	-
13	VSSRF	-	-	-	-
14	RFCLKp	A,O	NC	O	Hi-Z
15	RSSI / RFCLKm	A,I	RSSI	I	Hi-Z
16	VDDRF	-	-	-	-
17	RFCLKd	D,O	RFCLKd	O	O-L
18	TDO	A,O	TDO	O	-
19	RDI	D,I	RDI	I	I
20	SK	D,I/O	SK	-	O-L
21	PD1 / SIO	D,I/O	SIO	-	I-PD
22	LE	D,I/O	LE	O	O-H
23	P31 / PD1	D,I/O	RESET	O	I-PD
24	P32 / PD2	D,I/O	ROW0	I	I-PD
25	P33 / PD3	D,I/O	ROW1	I	I-PD
26	P34 / PD4	D,I/O	ROW2	I	I-PD
27	TDOD/ P35 / PD5	D,I/O	NC	O	I-PD
28	P36 / PD6	D,O	NC	O	I-PD
29	VSS2	-	-	-	-
30	VDDIO2	-	-	-	-
31	VDD2	-	-	-	-
32	PCM_FSC / INT0 / P10	D,I/O	RDY	I	I-PU
33	P00 / UTX	D,I/O	UTX	O	I-PU
34	P01 / URX	D,I/O	URX	I	I-PU
35	P02 / JTIO	D,I/O	JTIO	O	I-PU
36	P03 / SDA2	D, I/O	TAM_CS _n	O	I-PU
37	P04 / SCL2	D,O	TAM_RST _n	O	I-PU
38	P05 / SPICLK/PCM_CLK	D,I/O	SPICLK	O	I-PU
39	P06/ SPIDO/ PCM_DOUT	D,I/O	SPIDO	O	I-PU
40	P07 /SPIDI/ PCM_DIN	D,I/O	SPIDI	O	I-PU
41	VSS3	-	-	-	-
42	VDD3	-	-	-	-
43	P23 / ADC1	I	ADC1	I	I
44	P17 / CHARGE / INT7	I	CHARGE	I	I-PD
45	*RST	I	RST _n	I	I-PU
46	VBAT1	A,I	VBAT1	I	I
47	LDO1_CTRL	D,O	LDO1_CTRL	O	O-H
48	LDO2_CTRL	D,O	LDO2_CTRL	O	O-H
49	LDO1_Sense	D,I	LDO1_Sense	I	O-L
50	AVS2	-	-	-	-
51	AVD2	-	-	-	-
52	*CIDIN	A,I	CIDIN _n	I	I
53	*LSR / REF	A,O	REF	O	O
54	LSRp / REF	A,O	LSRp	O	O
55	RINGING	A,I	RINGING	I	I
56	*MIC / CIDOUT	A,I	CIDOUT	O	O
57	VREFm	-	-	-	-
58	AGND	A,O	AGND	O	O
59	MICp	A,I	MICp	I	I

Pin No.	Description	I/O	Connection	at Normal mode	at Reset mode
60	CIDINp	A,I	CIDINp	I	I
61	P14 / *INT4	D,O	HOOK	O	I
62	P13 / *INT3	D,O	NC	O	I
63	ADC2	A,I	ADC2	I	I
64	ADC0	A,I	ADC0	I	I

14.2. CPU Data (Handset)

14.2.1. IC1 (BBIC)

Pin No	Description	I/O	Connection	at Normal	at Reset mode
1	LED1/PWM0/P2[0]	D,O	LCD_BK	O	I-PU
2	LED2/PWM1/P2[1]	D,O	LCD_CSB	O	I-PU
3	SK	D,O	SK	O	O-L
4	SIO	D,I/O	SIO	I/O	I-PD
5	LE	D,I/O	LE	O	O-L
6	P3[1]/PD1	D,O	COL1	I/O	I-PD
7	P3[2]/PD2	D,O	COL2	I/O	I-PD
8	TDO	A,O	TDO	O	O-L
9	RDI	D,I	RDI	I	I
10	RSSI/RFCLKm	A,I	RSSI	I	I
11	VSSRF	S	VSSRF	S	-
12	CAP	A,I	CAP	I	I
13	Xtal1	A,I	Xtal1	I	I
14	AVS	S	AVS	S	-
15	AVD_XTAL	A,I	AVD_XTAL	I	I
16	VDDRF	S	VDDRF	S	-
17	RFCLKd	D,O	RFCLK	O	O-L
18	VDDIO	S	VDDIO	S	-
19	VDD	S	VDD	S	-
20	VSS	S	VSS	S	-
21	TDOD/P2[7]	D,O	NC	O	I-PU
22	SDA1/P2[5]	D,IO	LCD_SI	O	I
23	SCL1/P2[4]	D,IO	LCD_SCL	O	I
24	INT5n/P1[5]	D,IO	LCD_RS	O	O-H
25	INT2n/P1[2]	D,IO	ROW2	I	I-PU
26	BXTAL/P5[0]	D,IO	NC	O	I-PD
27	P4[0]	D,IO	NC	O	I-PD
28	P4[1]	D,IO	NC	O	I-PD
29	P4[2]	D,IO	NC	O	I-PD
30	P4[3]	D,IO	NC	O	I-PD
31	P4[4]	D,IO	NC	O	I-PD
32	P4[5]	D,IO	NC	O	I-PD
33	P4[6]	D,IO	NC	O	I-PD
34	P4[7]	D,IO	NC	O	I-PD
35	VSSPA	S	VSSPA	S	-
36	PAOUTp/P5[2]	A,O	PAOUTp	O	O-L
37	VDDPA	S	VDDPA	S	-
38	PAOUTp/P5[1]	A,O	PAOUTp	O	O-L
39	VSSPA	S	VSSPA	S	-
40	VSS	-	VSS	S	-
41	VDDIO	-	VDDIO	S	-
42	VDD	-	VDD	-	-
43	PCM1_CLK/P3[3]/PD3	D,O	COL3	I/O	I
44	PCM1_DOUT/P3[4]/PD4	D,O	COL4	I/O	I
45	PCM1_DIN/P3[5]/PD5	D,O	COL5	I/O	I
46	PCM1_FSC/P3[6]/PD6	D,O	NC	O	I
47	INT0n/P1[0]	D,I	ROW0	I	I-PU
48	SPI2_CLK/P3[7]	D,O	NC	O	I-PD
49	SPI2_DO/P0[0]/TRAX	D,O	UTX	O	I-PU
50	SPI2_DI/P0[1]/URX	D,O	URX	I	I-PU
51	P0[2]/JTIO	D,O	JTAG	I/O	I-PU
52	P0[3]/SDA2/UTX2	D,IO	EEP_SDA	I/O	I-PU
53	P0[4]/SCL2/URX/ SPI1_EN	D,O	EEP_SCL	O	I-PU
54	P0[5]/SPI1_CLK	D,O	BELL_LED	O	I-PU
55	P0[6]/SPI1_DO	D,O	NC	O	I-PU
56	P0[7]/SPI1_DI	D,O	RF_RESET	O	I-PU
57	VSS	S	VSS	S	-
58	VDD	S	VDD	S	-
59	VDDIO	S	VDDIO	S	-
60	P2[3]/ADC1	D,O	EEP_WP	O	I
61	P5[3]/PCM1_CLK	D,O	NC	O	I-PU

Pin No	Description	I/O	Connection	at Normal	at Reset mode
62	P5[4]/PCM1_FSC	D,O	NC	O	I-PU
63	P5[5]/PCM1_DOUT	D,O	NC	O	I-PU
64	P5[6]/PCM1_DIN	D,O	NC	O	I-PU
65	P1[7]/CHARGE/INT7n	D,I	CHARGE	I	I-PD
66	RSTn	D,I/O	RSTn	O	I-PU
67	DC_stab	S	DC_stab	S	-
68	DC_I	A,I	DC_I	I	I
69	DC_CTRL	A,O	DC_CTRL	O	O-PD
70	DC_Sence	A,I	DC_Sence	I	I
71	MODE2	A,I	MODE2	I	I
72	VBATp/SOCp	A,I	ADC3	I	I
73	VBAT1	A,I	VBAT1	I	I
74	LDO1_CTRL	A,O	LDO1_CTRL	O	I
75	LDO2_CTRL	A,O	LDO2_CTRL	O	I
76	P1[6]/PON/INT6n	D,I	POWER_KEY	I	I-PD
77	P2[6]/STOP_CHARGE	A,O	stop_charge	O	O
78	LDO1_Sence	A,I	LDO1_Sence	I	I
79	AVS2	S	AVS2	S	-
80	AVD2	S	AVD2	S	-
81	LSRn	A,O	LSRn	O	O
82	LSRp	A,O	LSRp	O	O

14.3. Terminal Guide of the ICs, Transistors and Diodes

14.3.1. Base Unit

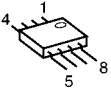
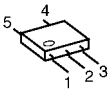
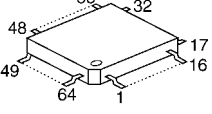
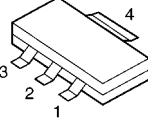
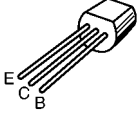
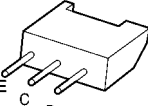
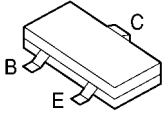
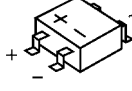
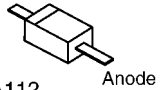
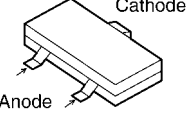
 <p>PQWID300NEHR</p>	 <p>C0JBAS000249</p>	 <p>C1CB00002311</p>	 <p>C0CBAYF00015</p>	 <p>B1ACGP000007</p>
 <p>2SD1994A</p>	 <p>PQVTBF822T7, B1ADGE000004 B1ADCF000040, B1ABGE000006 B1ABCF000103</p>		 <p>B0EDER000009</p>	 <p>Cathode Anode MA112 PQVDRLZ20A 1SS355 MA111</p>
 <p>B0DDCM000001</p>				

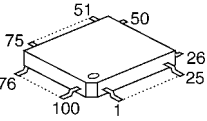
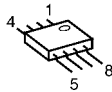
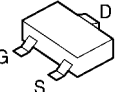
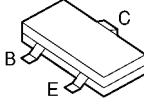
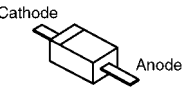
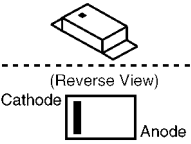
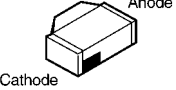

14.3.2. Handset

 <p>C1CB00002317</p>	 <p>PQWI2A120EXR</p>	 <p>PQVTFDN335N</p>	 <p>UN9219J, B1ADGE000004 B1ABCF000103</p>
 <p>B0BC2R1A0006, MA8047 MA2Z72000, B0JCME000035</p>	 <p>(Reverse View) Cathode Anode B3ACB0000133</p>	 <p>B3ACB0000134</p>	

15 Exploded View and Replacement Parts List

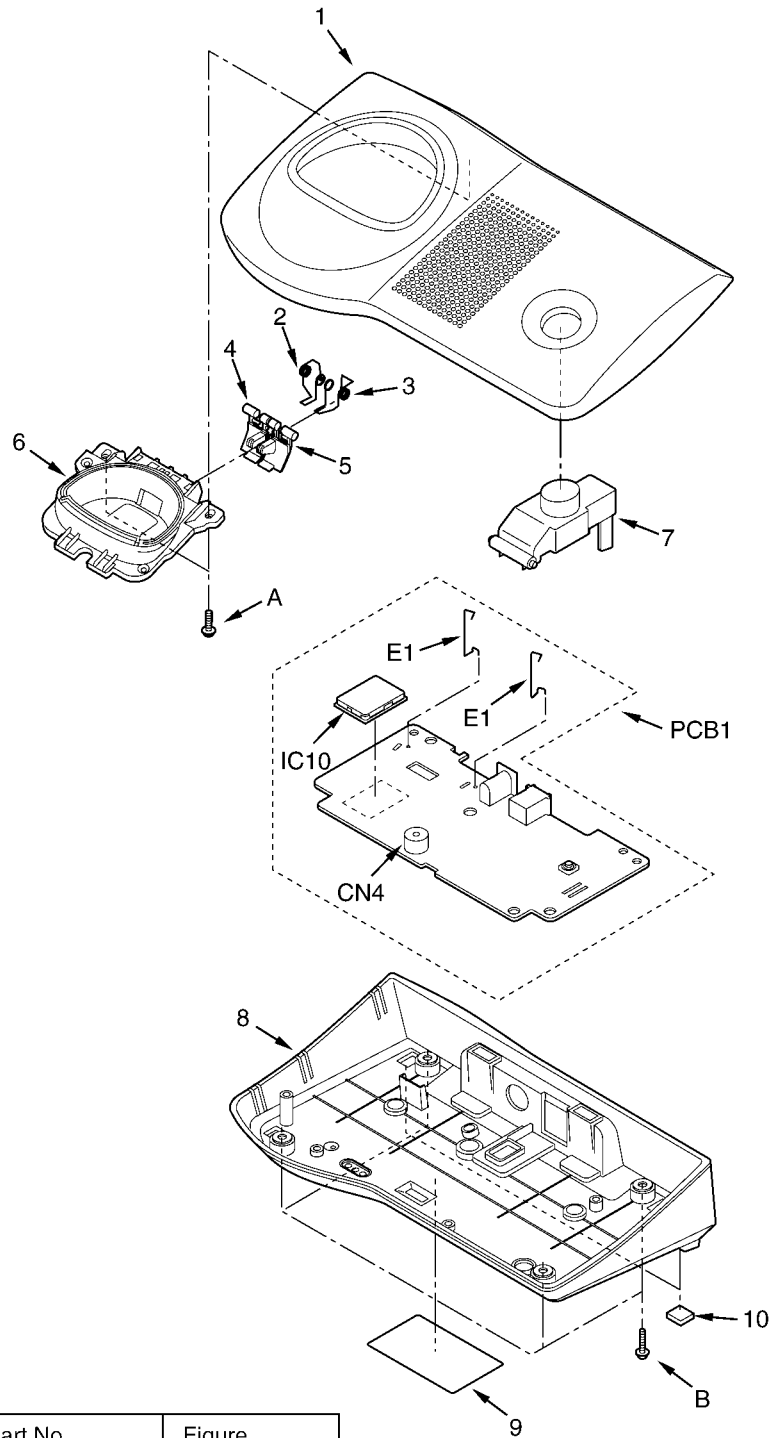
15.1. Cabinet and Electric Parts (Base Unit)



Ref.No.	Part No.	Figure
A	XTW26+T8PFJ	 φ2.6 × 8mm
B	XTW26+T14PFJ	 φ2.6 × 14mm

15.2. Cabinet and Electric Parts (Handset)

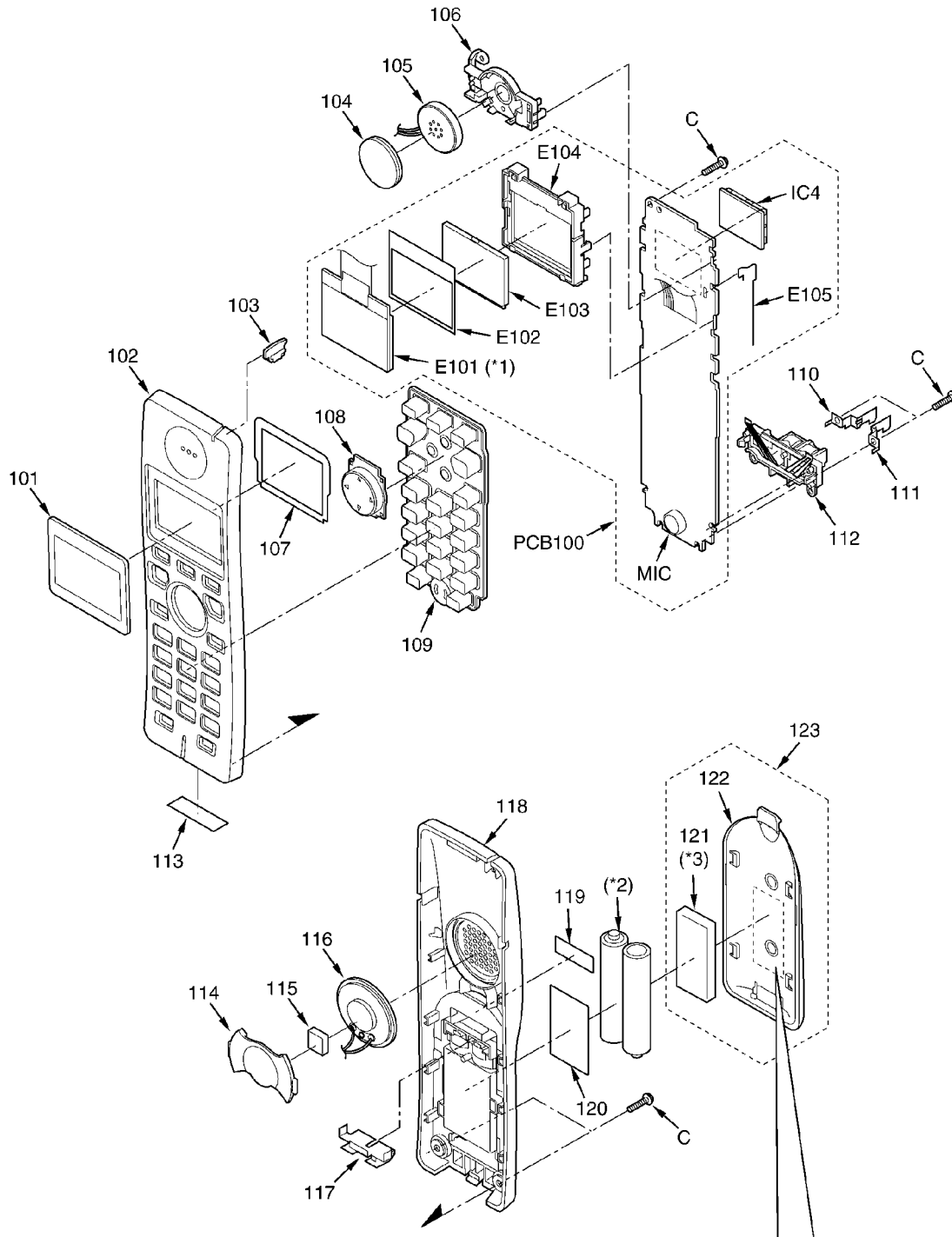

Ref.No.	Part No.	Figure
C	XTW2+R10PFJ	 φ2 × 10mm

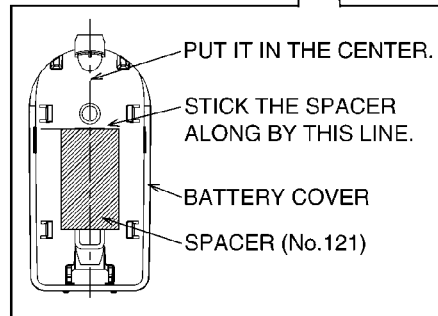

Note:

(*1) This cable is fixed by welding. Refer to **How to Replace the Handset LCD** (P.46).

(*2) The rechargeable Ni-MH battery P03P (HHR-4EPT, Capacity: up to 750mAh) is available through sales route of Panasonic.

(*3) Attach the spacer (No. 121) to the exact location described above.

15.3. Cabinet and Electric Parts (Charger Unit)

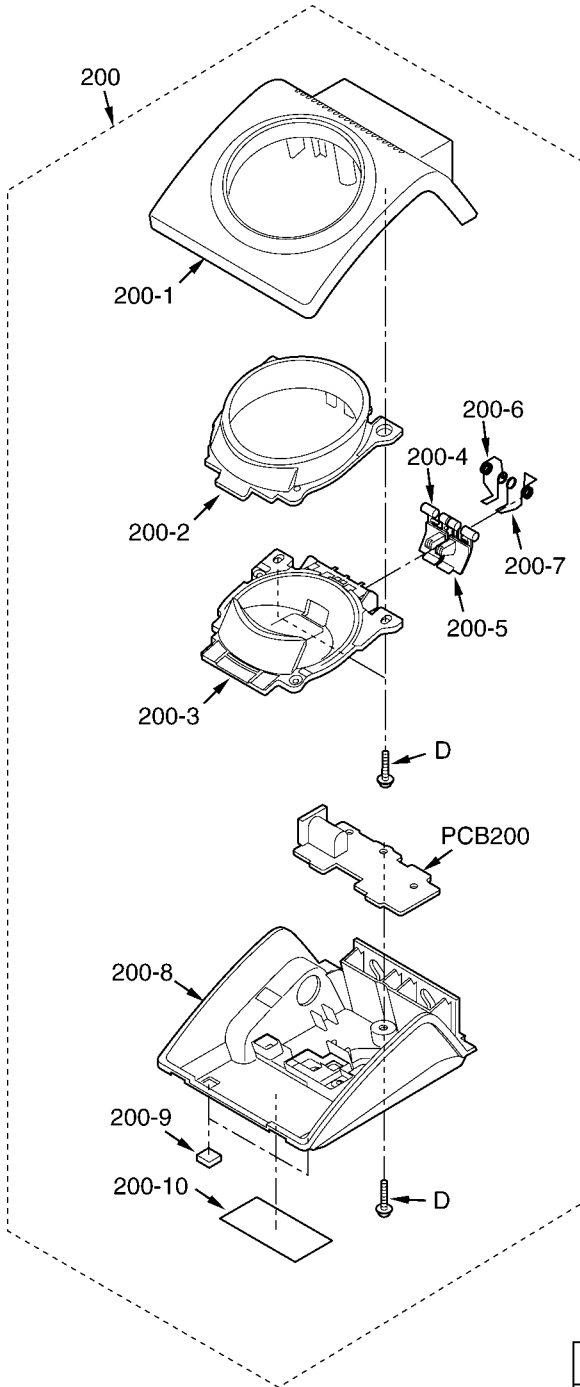

Ref.No.	Part No.	Figure
D	XTW26+T10PFJ	 φ2.6 × 10 mm

15.4. Accessories and Packing Materials

15.4.1. KX-TG7100ES

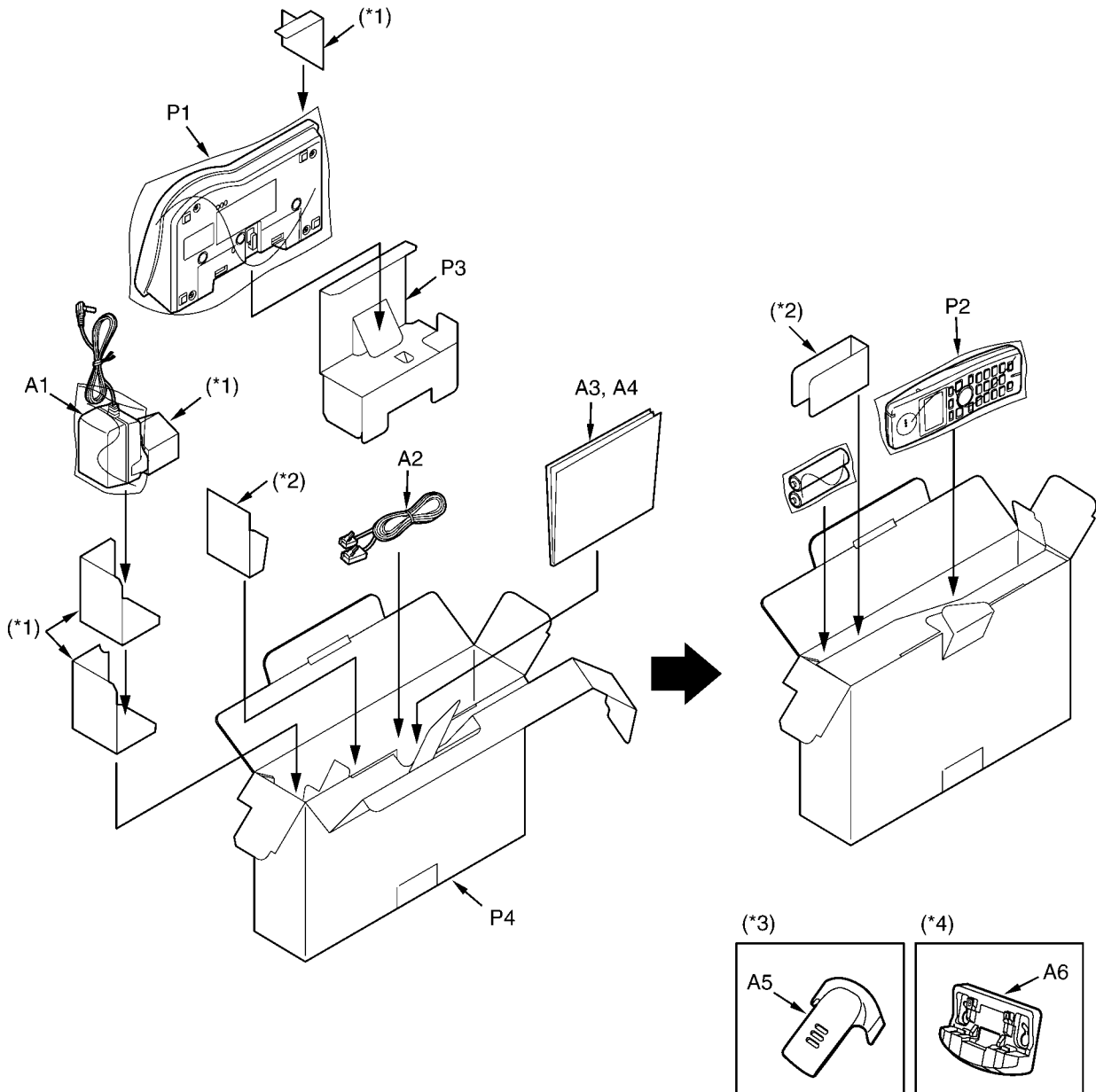

Note:

(*1) These pads are pieces of Ref No. P3 (CUSHION).

(*2) These pads are pieces of Ref No. P4 (GIFT BOX).

(*3) for Service

Model No. for A5 (BELT CLIP) through sales route of Panasonic is KX-TCA718EXH.

(*4) for Service

Model No. for A6 (WALL MOUNT) through sales route of Panasonic is KX-TCA717EXH.

15.4.2. KX-TG7102ES

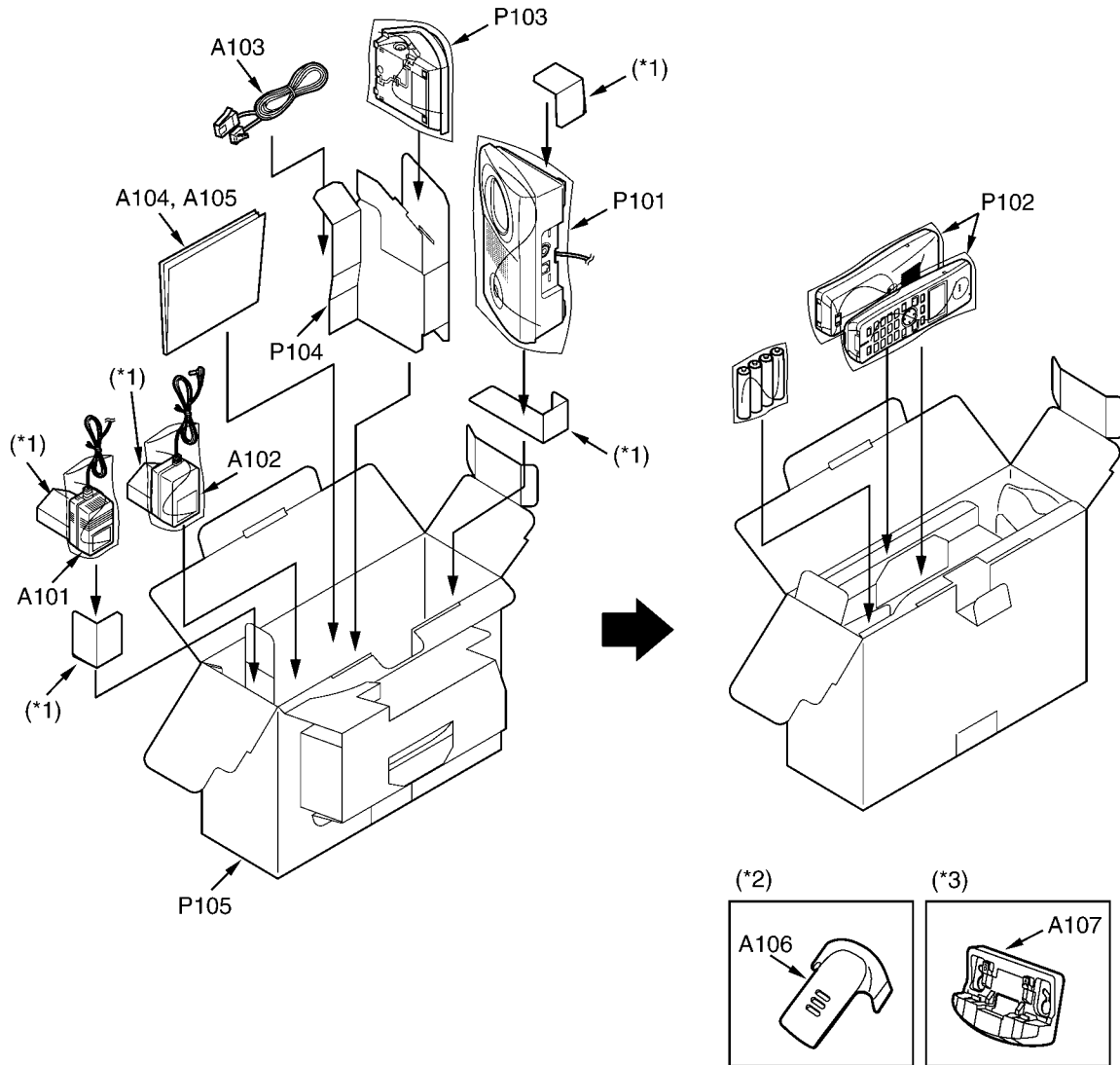

Note:

(*1) These pads are pieces of Ref No. P104 (CUSHION).

(*2) for Service
Model No. for A106 (BELT CLIP) through sales route of Panasonic is KX-TCA718EXH.

(*3) for Service
Model No. for A107 (WALL MOUNT) through sales route of Panasonic is KX-TCA717EXH.

15.4.3. KX-TG7103ES

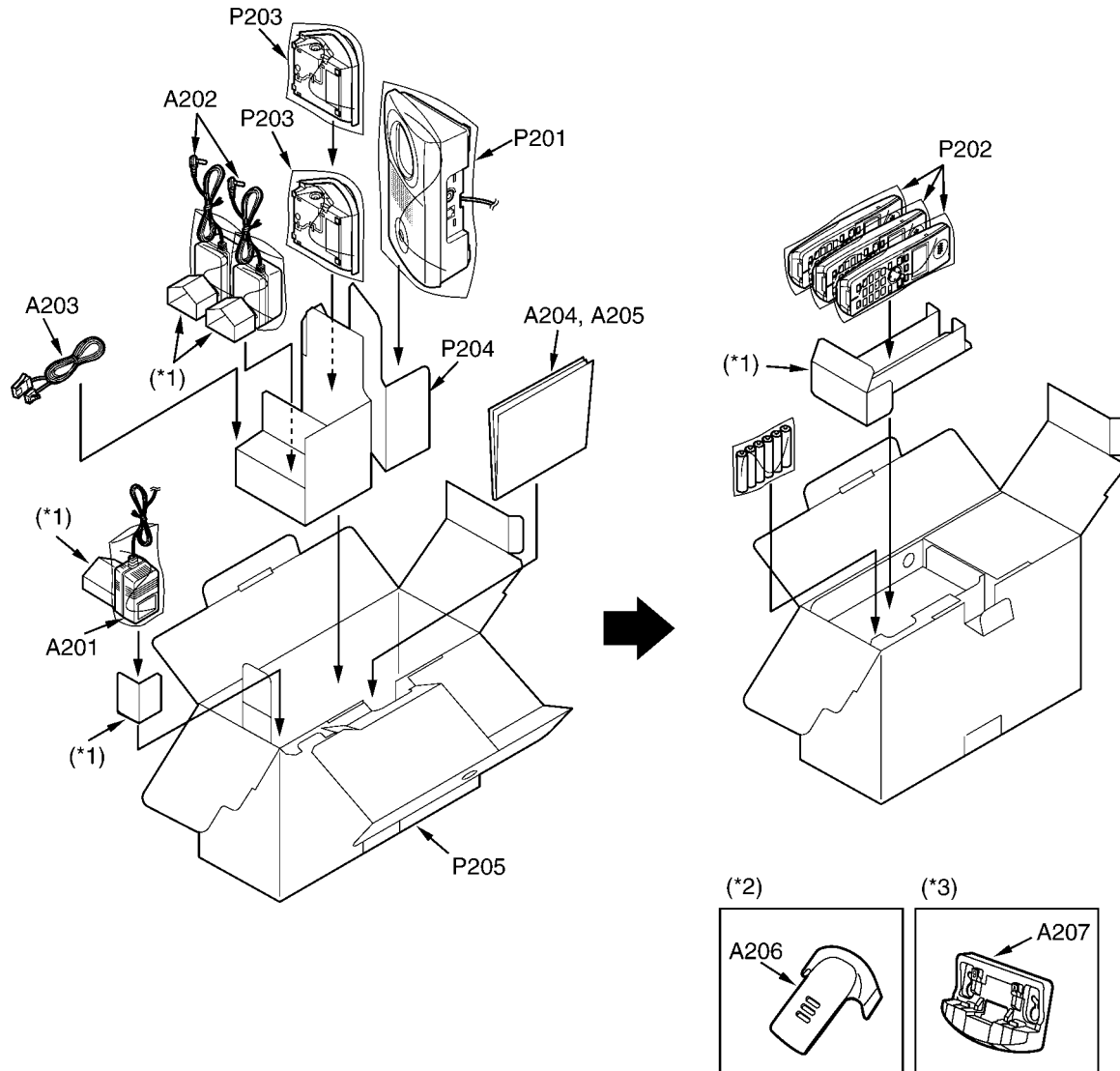

Note:

(*1) These pads are pieces of Ref No. P204 (CUSHION).

(*2) for Service

Model No. for A206 (BELT CLIP) through sales route of Panasonic is KX-TCA718EXH.

(*3) for Service

Model No. for A207 (WALL MOUNT) through sales route of Panasonic is KX-TCA717EXH.

15.5. Replacement Part List

1. RTL (Retention Time Limited)

Note:

The marking (RTL) indicates that the Retention Time is limited for this item.

After the discontinuation of this assembly in production, the item will continue to be available for a specific period of time. The retention period of availability is dependant on the type of assembly, and in accordance with the laws governing part and product retention. After the end of this period, the assembly will no longer be available.

2. Important safety notice

Components identified by the Δ mark indicates special characteristics important for safety. When replacing any of these components, only use specified manufacture's parts.

3. The S mark means the part is one of some identical parts.

For that reason, it may be different from the installed part.

4. ISO code (Example: ABS-94HB) of the remarks column shows quality of the material and a flame resisting grade about plastics.

5. RESISTORS & CAPACITORS

Unless otherwise specified;

All resistors are in ohms (Ω) K=1000 Ω , M=1000k Ω

All capacitors are in MICRO FARADS (μ F)P= μ μ F

*Type & Wattage of Resistor

Type

ERC:Solid ERDS:Carbon ERJ:Chip	ERX:Metal Film ERG:Metal Oxide ER0:Metal Film	PQ4R:Chip ERS:Fusible Resistor ERF:Cement Resistor
--------------------------------------	---	--

Wattage

10,16:1/8W	14,25:1/4W	12:1/2W	1:1W	2:2W	3:3W
------------	------------	---------	------	------	------

*Type & Voltage Of Capacitor

Type

ECFD:Semi-Conductor ECQS:Styrol ECUV,PQCUV,ECUE:Chip ECQMS:Mica	ECCD,ECKD,ECBT,F1K,ECUV: Ceramic ECQE,ECQV,ECQG: Polyester ECEA,ECST,EEE: Electlytic ECQP: Polypropylene
--	---

Voltage

ECQ Type	ECQG ECQV Type	ECSZ Type	Others		
1H:50V 2A:100V 2E:250V 2H:500V	05:50V 1:100V 2:200V	0F:3.15V 1A:10V 1V:35V 0J:6.3V	0J :6.3V 1A :10V 1C :16V 1E,25:25V	1V :35V 50,1H:50V 1J :16V 2A :100V	

15.5.1. Base Unit

15.5.1.1. Cabinet and Electrical Parts

Ref. No.	Part No.	Part Name & Description	Remarks
1	PQKM10719Z1	CABINET BODY	PS-HB
2	PQJT10241Z	CHARGE TERMINAL (L)	
3	PQJT10242Y	CHARGE TERMINAL (R)	
4	PQKE10454Z1	HOLDER, CHARGE TERMINAL (L)	POM-HB
5	PQKE10455Z1	HOLDER, CHARGE TERMINAL (R)	POM-HB
6	PQKE10452Z1	CASE, CHARGE TERMINAL	PS-HB
7	PQBC10468Z1	BUTTON, LOCATOR	ABS-HB
8	PQKF10708Z1	CABINET COVER	PS-HB
9	PQGT18534Z	NAME PLATE	

Ref. No.	Part No.	Part Name & Description	Remarks
10	PQHA10023Z	RUBBER PARTS, FOOT CUSHION	

15.5.1.2. Main P.C.Board Parts

Note:

(*1) When replacing IC5 and IC7, data need to be written to them with PQZZTG7100E. Refer to **Base Unit (P.54) of Things to Do after Replacing IC**

Ref. No.	Part No.	Part Name & Description	Remarks
PCB1	PQWPG7100EH	MAIN P.C.BOARD ASS'Y (RTL)	
		(ICs)	
IC1	C0CBAYF00015	IC	
IC4	C0JBAS000249	IC	
IC5	PQWID300NEHR	IC (EEPROM) (*1)	
IC6	C0JBAS000249	IC	
IC7	C1CB00002311	IC (BBIC) (*1)	S
		(TRANSISTORS)	
Q3	B1ACGP000007	TRANSISTOR (SI)	
Q4	PQVTBF822T7	TRANSISTOR (SI)	
Q5	2SD1994A	TRANSISTOR (SI)	
Q6	B1ABGE000006	TRANSISTOR (SI)	
Q7	B1ABCF000103	TRANSISTOR (SI)	
Q8	B1ADGE000004	TRANSISTOR (SI)	
Q9	B1ADGE000004	TRANSISTOR (SI)	
Q10	B1ADGE000004	TRANSISTOR (SI)	
Q14	B1ADCF000040	TRANSISTOR (SI)	
		(DIODES)	
D3	B0EDER000009	DIODE (SI)	
D4	PQVDR LZ20A	DIODE (SI)	S
D9	1SS355	DIODE (SI)	S
D11	MA111	DIODE (SI)	S
D12	MA112	DIODE (SI)	S
DA1	B0DDCM000001	DIODE (SI)	
		(COILS)	
L1	PQLQXF330K	COIL	S
L2	PQLQXF330K	COIL	S
L3	MQLRF6N8JFB	COIL	
L4	MQLRF6N8JFB	COIL	
L7	PQLQR2M33NKT	COIL	S
L10	ELJRF2N2ZFB	COIL	S
L11	ELJRF2N2ZFB	COIL	S
		(JACKS)	
CN1	K2LB102B0053	JACK	S
CN2	K2ECYB000001	JACK	S
		(VARISTOR)	
SA1	J0LF00000026	VARISTOR (SURGE ABSORBER)	
		(RESISTORS)	
R1	ERJ2GEJ103	10K	
R3	ERJ3GEYJ184	180K	
R4	ERJ3GEYJ105	1M	
R5	ERJ3GEYJ184	180K	
R6	ERJ3GEYJ105	1M	
R8	ERJ3GEYJ104	100K	
R10	ERJ3GEYJ104	100K	
R14	ERJ3GEYJ104	100K	
R15	PQ4R10XJ272	2.7K	S
R16	ERJ3GEYJ103	10K	
R17	ERJ3GEYJ222	2.2K	
R18	ERJ3GEYJ273	27K	
R19	ERJ3GEYJ822	8.2K	
R20	ERJ3GEYJ182	1.8K	
R21	ERJ12YJ120	12	
R22	ERJ12YJ270	27	
R23	ERJ3GEYJ104	100K	
R24	ERJ3GEYJ473	47K	
R27	ERJ3GEYJ104	100K	
R28	ERJ3GEYJ474	470K	
R29	ERJ2GEJ560X	56	
R30	ERJ3GEYJ391	390	
R31	ERJ3GEYJ182	1.8K	
R32	ERJ3GEYJ104	100K	

Ref. No.	Part No.	Part Name & Description	Remarks
R33	ERJ2GEJ102	1K	
R34	ERJ3GEYJ104	100K	
R35	ERJ3GEYJ102	1K	
R36	ERJ2GEJ104	100K	
R38	ERJ2RKF1200	120	
R39	ERJ2RKF2000	200	
R48	ERJ8GEYJ270	27	
R49	ERJ2GEJ471	470	
R51	ERJ3GEYJ122	1.2K	
R52	ERJ2GEJ153	15K	
R53	ERJ3GEYJ181	180	
R54	ERJ2GEJ102	1K	
R55	ERJ1WYJ220	22	
R56	ERJ1WYJ220	22	
R57	ERJ2GEJ392	3.9K	
R58	ERJ2GEJ682	6.8K	
R59	ERJ3GEYJ222	2.2K	
R60	ERJ2GEJ223	22K	
R61	ERJ2GEJ102	1K	
R62	ERJ2GEJ222	2.2K	
R63	ERJ2GEJ222	2.2K	
R66	ERJ3GEY0R00	0	
R67	ERJ2GEJ180	18	
R71	ERJ2GEJ332	3.3K	
R72	ERJ2GEJ150	15	
R73	ERJ2GEJ335	3.3M	
R74	ERJ2GEJ103	10K	
R75	ERJ2GEJ101	100	
R76	ERJ2GEJ102	1K	
R77	ERJ2GEJ103	10K	
R78	ERJ2GEJ103	10K	
R79	ERJ2GEJ102	1K	
R80	ERJ2GEJ102	1K	
R81	ERJ2GEJ332	3.3K	
R89	ERJ2GEJ103	10K	
R92	ERJ2GEJ102	1K	
R95	ERJ2GE0R00	0	
R96	ERJ2GE0R00	0	
R98	ERJ2GEJ103	10K	
R99	ERJ2GEJ103	10K	
R102	ERJ3GEYJ222	2.2K	
R103	PQ4R10XJ471	470	S
R106	ERJ3GEYJ271	270	
R109	ERJ3GEYJ181	180	
R111	ERJ2GEJ101	100	
R112	ERJ2GEJ102	1K	
R114	ERJ2GE0R00	0	
R116	ERJ2GEJ180	18	
R117	ERJ2GEJ332	3.3K	
R121	ERJ3GEY0R00	0	
L9	ERJ2GE0R00	0	
		(CAPACITORS)	
C1	ECUE1H100DCQ	10P	S
C3	F1B2H152A048	1500P	
C4	F1B2H152A048	1500P	
C5	ECUV1H102KBV	0.001	
C6	ECUV1H102KBV	0.001	
C7	ECUV1H100DCV	10P	
C8	ECUV1H100DCV	10P	
C9	ECKD2H681KB	680P	S
C10	ECKD2H681KB	680P	S
C14	ECUV1H472KBV	0.0047	
C15	PQCUV1A105KB	1	
C16	PQCUV1A225KB	2.2	
C17	PQCUV1A225KB	2.2	
C19	ECUV1H100DCV	10P	
C22	PQCUV1A105KB	1	
C23	ECUV1C563KBV	0.056	
C25	ECUV1H103KBV	0.01	
C27	ECEA1HKA100	10	
C28	PQCUV1H104ZF	0.1	S
C31	PQCUV1A225KB	2.2	
C32	ECA1CM101	100P	

Ref. No.	Part No.	Part Name & Description	Remarks
C36	ECEA0JSJ331	330	S
C37	ECUV1H100DCV	10P	
C44	ECUE1H101JCQ	100P	S
C47	ECUV1C104KBV	0.1	
C48	ECUV1H100DCV	10P	
C49	ECUV1H100DCV	10P	
C50	ECJOEB1C103K	0.01	
C51	F1G1A1040003	0.1	
C52	ECUV1H221JCV	220P	
C53	ECUV1H221JCV	220P	
C54	ECUE1C223KBQ	0.022	S
C55	F1G1A1040003	0.1	
C56	ECUV1C104KBV	0.1	
C59	F1G1A1040003	0.1	
C60	F1G1A1040003	0.1	
C61	F1G1A1040003	0.1	
C62	ECJOEC1H270J	27P	
C63	ECUV1H150JCV	15P	
C64	ECEA1CKS100	10	
C65	ECJOEB0J105K	1	
C67	F1G1A1040003	0.1	
C68	ECJOEB0J105K	1	
C70	ECUV1A105KBV	1	
C71	ECEA1CKS100	10	
C72	F1G0J2240003	0.22	
C73	F1G1A1040003	0.1	
C74	F1G1A1040003	0.1	
C75	F1G1A1040003	0.1	
C102	PQCUV1A105KB	1	
C110	ECUE1H102KBQ	0.001	S
C112	ECJOEC1H220J	22P	
C117	ECUV1H030CCV	3P	
C118	ECUV1H100DCV	10P	
C119	ECUE1H100DCQ	10P	S
C120	ECUV1H100DCV	10P	
C124	ECUV1H010CCV	1P	
C125	ECUV1H100DCV	10P	
C126	F1G1H151A541	150P	S
C127	ECUE1H102KBQ	0.001	S
C133	F1G1A1040003	0.1	
C136	ECUE1H100DCQ	10P	S
C137	ECUE1H100DCQ	10P	S
C140	ECJOEB1A104K	0.1	
C141	ECJOEB1A563K	0.056	
C143	ECUE1H100DCQ	10P	S
C147	ECUE1H100DCQ	10P	S
C148	ECUV1H100DCV	10P	
C149	ECUE1H100DCQ	10P	S
C151	ECUE1H100DCQ	10P	S
C152	ECUE1H100DCQ	10P	S
C153	ECUE1H100DCQ	10P	S
C154	ECUE1H100DCQ	10P	S
L6	ECUV1H0R5CCV	0.5P	
		(OTHERS)	
E1	PQSA10187Z	ANTENNA	
IC10	PQLP10263Z	RF UNIT	
CN4	L0DACA000024	BUZZER	
SW1	EVQQJJ05Q	SPECIAL SWITCH	
X1	H0D103500003	CRYSTAL OSCILLATOR	

15.5.2. Handset

15.5.2.1. Cabinet and Electrical Parts

Ref. No.	Part No.	Part Name & Description	Remarks
101	PQGP10302Z1	PANEL, LCD	PC-HB
102	PQKM10709Y2	CABINET BODY	ABS-HB
103	PQHR11204Z	OPTIC CONDUCTIVE PARTS/LED LENDS	PS-HB
104	PQHS10467Z	COVER, SP NET	
105	L0AD02A00028	SPEAKER	
106	PQHR11197Z	GUIDE, SPEAKER	ABS-HB

Ref. No.	Part No.	Part Name & Description	Remarks
107	PQHS10722Y	SPACER, LCD CUSHION	
108	PQBC10458Y2	PUSH BUTTON, NAVIGATOR KEY	ABS-HB
109	PQSX10315Z	KEYBOARD SWITCH	
110	PQJT10240Z	CHARGE TERMINAL (R)	
111	PQJT10239Z	CHARGE TERMINAL (L)	
112	PQWE10045Z	BATTERY TERMINAL	ABS-HB
113	PQGT18556Z	NAME PLATE	
114	PQHR11198Z	GUIDE, SPEAKER	ABS-HB
115	PQHG10729Z	RUBBER PARTS, SPEAKER	
116	LOAD02A00026	SPEAKER	
117	PQJC10056Y	BATTERY TERMINAL	
118	PQKF10713Z1	CABINET COVER	ABS-HB
119	PQQT23182Z	LABEL, ATTENTION	
120	PQHX11396Z	PLASTIC PARTS, BATTERY COVER SHEET	
121	PQHS10561Y	SPACER, BATTERY COVER	
122	PQKK10595X3	LID, BATTERY COVER	ABS-HB
123	PQYNTG8100ES	LID, BATTERY COVER ASS'Y	ABS-HB

15.5.2.2. Main P.C.Board Parts

Note:

(*1) When replacing IC1 and IC3, data need to be written to it with PQZZTG7100E. Refer to **Handset (P.54) of Things to Do after Replacing IC**

(*2) When replacing the Handset LCD, See **How to Replace the Handset LCD (P.46)**.

Ref. No.	Part No.	Part Name & Description	Remarks
PCB100	PQWPG7100ER	MAIN P.C.BOARD ASS'Y (RTL)	
		(ICs)	
IC1	C1CB00002317	IC (BBIC) (*1)	
IC3	PQWI2A120EXR	IC (EEPROM) (*1)	
		(TRANSISTORS)	
Q1	PQVTFDN335N	TRANSISTOR (SI)	S
Q2	BIADGE000004	TRANSISTOR (SI)	
Q3	BIADGE000004	TRANSISTOR (SI)	
Q4	BIADGE000004	TRANSISTOR (SI)	
Q5	BIABCF000103	TRANSISTOR (SI)	
Q7	UN9219J	TRANSISTOR (SI)	S
Q8	UN9219J	TRANSISTOR (SI)	S
Q9	UN9219J	TRANSISTOR (SI)	S
Q10	BIABCF000103	TRANSISTOR (SI)	
Q11	BIABCF000103	TRANSISTOR (SI)	
Q12	UN9219J	TRANSISTOR (SI)	S
		(DIODES)	
D1	B0JCME000035	DIODE (SI)	
D4	MA8047	DIODE (SI)	S
D5	MA8047	DIODE (SI)	S
D6	B0BC2R1A0006	DIODE (SI)	
D7	MA2Z72000	DIODE (SI)	
LED1	B3ACB0000133	LED	
LED2	B3ACB0000133	LED	
LED3	B3ACB0000133	LED	
LED4	B3ACB0000133	LED	
LED5	B3ACB0000133	LED	
LED6	B3ACB0000133	LED	
LED7	B3ACB0000133	LED	
LED8	B3ACB0000133	LED	
LED9	B3ACB0000133	LED	S
LED10	B3ACB0000134	LED	
		(COILS)	
L1	G1C470M00025	COIL	
L4	G1C100MA0072	COIL	
L5	G1C100MA0072	COIL	
F1	PQLQR2M5N6K	COIL	S
		(LCR FILTER)	
L6	J0JCC0000287	LCR FILTER	
		(RESISTORS)	
R1	ERJ6RSJR10V	0.1	
R2	ERJ3GEYJ680	68	
R5	ERJ2GEJ471	470	

Ref. No.	Part No.	Part Name & Description	Remarks
R6	ERJ2GEJ103	10K	
R7	ERJ2GEJ224	220K	
R8	ERJ2GEJ102	1K	
R11	ERJ3GEYJ393	39K	
R12	PQ4R10XJ4R7	4.7	S
R13	ERJ3GEYJ101	100	
R16	ERJ3GEYJ181	180	
R19	ERJ3GEYJ565	5.6M	
R21	ERJ2GEJ330	33	
R22	ERJ3GEYJ330	33	
R23	ERJ2GEJ102	1K	
R24	ERJ2GEJ102	1K	
R25	ERJ2GEJ222	2.2K	
R40	ERJ3GEYJ103	10K	
R41	ERJ3GEYJ103	10K	
R42	ERJ3GEYJ104	100K	
R43	ERJ2GEJ684	680K	
R44	ERJ2GEJ103	10K	
R45	ERJ6RSFR10V	0.1	
R46	ERJ2GE0R00	0	
R47	ERJ2GE0R00	0	
R51	ERJ2GEJ221	220	
R52	ERJ2GEJ102	1K	
R61	ERJ2GEJ102	1K	
R62	ERJ2GEJ102	1K	
R64	ERJ3GEYJ103	10K	
R65	ERJ3GEYJ103	10K	
R66	ERJ3GEYJ102	1K	
R91	ERJ3GEYJ100	10	
R92	ERJ2GEJ121	120	
R93	ERJ3GEYJ104	100K	
R94	ERJ3EKF4303	430K	
R95	ERJ3EKF8203	820K	
R96	ERJ2GEJ100	10	
R97	ERJ2GEJ393X	39K	
R98	ERJ2GEJ393X	39K	
R99	ERJ2GEJ393X	39K	
R100	ERJ2GEJ393X	39K	
R101	ERJ2GEJ393X	39K	
R102	ERJ2GEJ393X	39K	
R103	ERJ6GEYJ3R3	3.3	
R104	ERJ6GEYJ3R3	3.3	
L7	ERJ2GEJ100	0	
		(CAPACITORS)	
C1	EEE0GA331WP	330	
C2	EEE0JA331P	330	
C3	ECUV1C104KBV	0.1	
C4	ECUV1H100DCV	10P	
C5	PQCUV1A225KB	2.2	S
C6	ECJ0EC1H080D	8P	
C7	ECJ0EC1H150J	15P	
C8	FIG1A2240008	0.22	
C10	PQCUV1A225KB	2.2	S
C11	ECUV1C104KBV	0.1	
C15	ECUV1A105KBV	1	
C18	ECJ0EB1H102K	0.001	
C19	ECUV1C104KBV	0.1	
C21	ECJ0EB1A104K	0.1	
C22	ECJ0EB1A104K	0.1	
C24	ECJ0EB1A104K	0.1	
C25	ECJ0EB1A104K	0.1	
C26	ECUV1C104KBV	0.1	
C32	ECJ0EB1A104K	0.1	
C35	ECJ0EC1H101J	100P	
C37	ECJ0EC1H101J	100P	
C38	ECJ0EB1C103K	0.01	
C39	ECUV1H100DCV	10P	
C40	ECUV1A105KBV	1	
C41	ECUV1A105KBV	1	
C42	ECUV1A105KBV	1	
C43	ECUV1A105KBV	1	
C44	ECUV1A105KBV	1	
C45	ECUV1A105KBV	1	

Ref. No.	Part No.	Part Name & Description	Remarks
C46	ECUV1A105KEV	1	
C47	ECUV1A105KEV	1	
C48	ECJOEB1A104K	0.1	
C49	ECJOEB1H102K	0.001	
C50	ECJOEC1H100D	10P	
C52	ECJOEB1H102K	0.001	
C53	F1G1H151A541	150P	
C57	ECJOEC1H220J	22P	
C58	ECJOEB1H102K	0.001	
C60	F1J0J4750005	4.7	
C61	F1J0J4750005	4.7	
C66	ECJOEC1H1R5C	1.5P	
C71	ECJOEC1H100D	10P	
C93	ECUV1H101JCV	100P	
C94	ECUV1H101JCV	100P	
C95	ECUV1A105KEV	1	
C96	ECJOEC1H100D	10P	
C97	ECJOEC1H100D	10P	
C98	ECJOEC1H100D	10P	
C99	ECJOEC1H100D	10P	
C100	ECJOEC1H100D	10P	
	(OTHERS)		
MIC	L0CBAB000052	MICROPHONE	
E101	L5DCAYY00005	LIQUID CRYSTAL DISPLAY (*2)	
E102	PQHX11378Z	COVER, LCD COVER SHEET	
E103	PQHR11195Z	TRANSPARENT PLATE, LCD PLATE	
E104	PQHR11205Z	GUIDE, LCD	
E105	PQSA10197Z	ANTENNA	
IC4	PQLP10263Z	RF UNIT	
D8	D4ED1270A014	VARISTOR (SURGE ABSORBER)	
X1	H0D103500005	CRYSTAL OSCILLATOR	

15.5.3. Charger Unit

15.5.3.1. Cabinet and Electrical Parts

Ref. No.	Part No.	Part Name & Description	Remarks
200	PQLV30045ZS	CHARGER UNIT	
200-1	PQKM10721Z3	CABINET BODY	PS-HB
200-2	PQGG10410Y1	GRILLE	ABS-HB
200-3	PQKE10436Y2	CASE, CHARGE TERMINAL	PS-HB
200-4	PQKE10454Z1	HOLDER, CHARGE TERMINAL (L)	POM-HB
200-5	PQKE10455Z1	HOLDER, CHARGE TERMINAL (R)	POM-HB
200-6	PQJT10241Z	CHARGE TERMINAL (L)	
200-7	PQJT10242Y	CHARGE TERMINAL (R)	
200-8	PQKF10709X1	CABINET COVER	ABS-HB
200-9	PQHA10023Z	RUBBER PARTS, FOOT CUSHION	
200-10	PQGT18544Z	NAME PLATE	

15.5.3.2. Main P.C.Board Parts

Ref. No.	Part No.	Part Name & Description	Remarks
PCB200	PQWPA810ESCH	MAIN P.C.BOARD ASS'Y (RTL)	
		(JACK)	
J1	K2ECYB000001	JACK	S
		(RESISTORS)	
R1	ERDS1VJ100	10	S
R2	ERDS1TJ120	12	S
R3	ERDS1VJ100	10	S
R4	ERDS1TJ120	12	S

15.5.4. Accessories and Packing Materials

Note:

(*1) You can download and refer to the Operating Instructions (Instruction book) on TSN Server.

15.5.4.1. KX-TG7100ES

Ref. No.	Part No.	Part Name & Description	Remarks
A1	PQLV207EZ	AC ADAPTOR	△
A2	PQJA87S	CORD, TELEPHONE	
A3	PQXX15057Z	INSTRUCTION BOOK (for English) (*1)	
A4	PQQW15103Y	QUICK GUIDE (for English)	
A5	PQKE10456Z1	HANGER, BELT CLIP (for Service)	PC+ABS-HB
A6	PQKL10074Z1	STAND, WALL MOUNT (for Service)	ABS-HB
P1	PQPP10116Z	PROTECTION COVER (for Base Unit)	
P2	PQPP10084Z	PROTECTION COVER (for Handset)	
P3	PQPD10734Z	CUSHION	
P4	PQPK15113Z	GIFT BOX	

15.5.4.2. KX-TG7102ES

Ref. No.	Part No.	Part Name & Description	Remarks
A101	PQLV207EZ	AC ADAPTOR (for Base Unit)	△
A102	PQLV209EZ	AC ADAPTOR (for Charger Unit)	△
A103	PQJA87S	CORD, TELEPHONE	
A104	PQXX15057Z	INSTRUCTION BOOK (for English) (*1)	
A105	PQQW15103Y	QUICK GUIDE (for English)	
A106	PQKE10456Z1	HANGER, BELT CLIP (for Service)	PC+ABS-HB
A107	PQKL10074Z1	STAND, WALL MOUNT (for Service)	ABS-HB
P101	PQPP10116Z	PROTECTION COVER (for Base Unit)	
P102	PQPH10094Z	PROTECTION COVER (for Handset)	
P103	PQPP10086Z	PROTECTION COVER (for Charger Unit)	
P104	PQPD10753Z	CUSHION	
P105	PQPK15233Z	GIFT BOX	

15.5.4.3. KX-TG7103ES

Ref. No.	Part No.	Part Name & Description	Remarks
A201	PQLV207EZ	AC ADAPTOR (for Base Unit)	△
A202	PQLV209EZ	AC ADAPTOR (for Charger Unit)	△
A203	PQJA87S	CORD, TELEPHONE	
A204	PQXX15057Z	INSTRUCTION BOOK (for English) (*1)	
A205	PQQW15103Y	QUICK GUIDE (for English)	
A206	PQKE10456Z1	HANGER, BELT CLIP (for Service)	PC+ABS-HB
A207	PQKL10074Z1	STAND, WALL MOUNT (for Service)	ABS-HB
P201	PQPP10116Z	PROTECTION COVER (for Base Unit)	
P202	PQPH10094Z	PROTECTION COVER (for Handset)	
P203	PQPP10086Z	PROTECTION COVER (for Charger Unit)	
P204	PQPD10754Z	CUSHION	
P205	PQPK15238Z	GIFT BOX	

15.5.5. Fixtures and Tools

Note:

(*1) See The Setting Method of JIG (Base Unit) (P.47), and The Setting Method of JIG (Handset) (P.51).

(*2) When replacing the Handset LCD, See How to Replace the Handset LCD (P.46).

Part No.	Part Name & Description	Remarks
PQZZ1CD300E	JIG CABLE (*1)	
PQZZTG7100E	BATCH FILE CD-ROM (*1)	
PQZZ430PIR	TIP OF SOLDERING IRON (*2)	
PQZZ430PRB	RUBBER OF SOLDERING IRON (*2)	

I.N./I
KXTG7100ES
KXTG7102ES
KXTG7103ES
KXTGA710ES