

Contents

Safety Notice	2
Chassis Block Diagram	3-4
IC Block Diagrams	5-6
IC201 Port Function	7
Service Information	8
Service Adjustments with replacing Memory IC (IC801)	9-13
Service Mode Adjustments	14-15
Service Adjustments	16
Special Function	17
Purity and Convergence Adjustment	18-19
Cabinet Parts List	20
Chassis Electrical Parts List	21-30
Component Locations	31-33
Voltages and Waveforms Charts	33-34

Safety Notice

SAFETY PRECAUTIONS

- | | |
|----------------------------------------------------------------------------------------------------------------------------------------------------------------------------------------------------------------------------------------------------------------------------------------------------------------------------------------------------|---------------------------------------------------------------------------------------------------------------------------------------------------------------------------------------------------------------------------------------------------------------------------------------------------------------------------------------------------------------------------------------------------------|
| <p>1: An isolation transformer should be connected in the power line between the receiver and the AC line when a service is performed on the primary of the converter transformer of the set.</p> <p>2: Comply with all caution and safety-related notes provided on the cabinet back, inside the cabinet, on the chassis or the picture tube.</p> | <p>3: When replacing a chassis in the cabinet, always be certain that all the protective devices are installed properly, such as, control knobs, adjustment covers or shields, barriers, isolation resistor-capacitor networks etc.. Before returning any television to the customer, the service technician must be sure that it is completely safe to operate without danger of electrical shock.</p> |
|----------------------------------------------------------------------------------------------------------------------------------------------------------------------------------------------------------------------------------------------------------------------------------------------------------------------------------------------------|---------------------------------------------------------------------------------------------------------------------------------------------------------------------------------------------------------------------------------------------------------------------------------------------------------------------------------------------------------------------------------------------------------|

X-RADIATION PRECAUTION

The primary source of X-RADIATION in television receiver is the picture tube. The picture tube is specially constructed to limit X-RADIATION emissions. For continued X-RADIATION protection, the replacement tube must be the same type as the original including suffix letter. Excessive high voltage may produce potentially hazardous X - RADIATION. To avoid such hazards, the high voltage must be maintained within specified limit. Refer to this service manual, high voltage adjustment for specific high voltage limit. If high voltage exceeds specified limits, take necessary corrective action. Carefully follow the instructions for + B1 volt power supply adjustment, and high voltage check to maintain the high voltage within the specified limits.

PRODUCT SAFETY NOTICE

Product safety should be considered when a component replacement is made in any area of a receiver. Components indicated by mark \triangle in the parts list and the schematic diagram designate components in which safety can be of special significance. It is particularly recommended that only parts designated on the parts list in this manual be used for component replacement designated by mark \triangle . No deviations from resistance wattage or voltage ratings may be made for replacement items designated by mark \triangle .

Chassis Block Diagrams

MAIN SIGNAL PROCESSING CIRCUIT

* S-Terminal and S-Woofer speaker are not equipped.

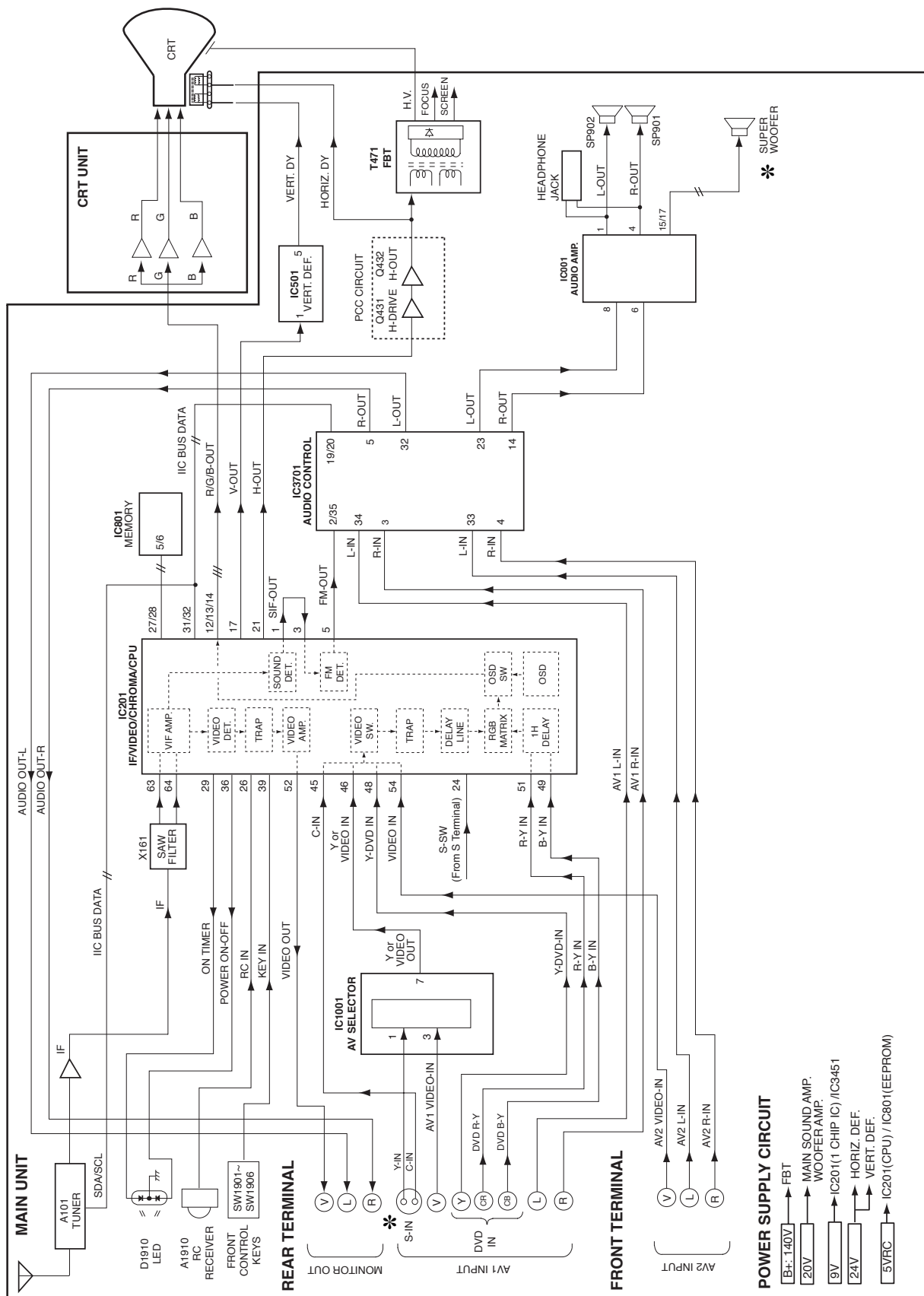

Chassis Block Diagrams

SYSTEM CONTROL

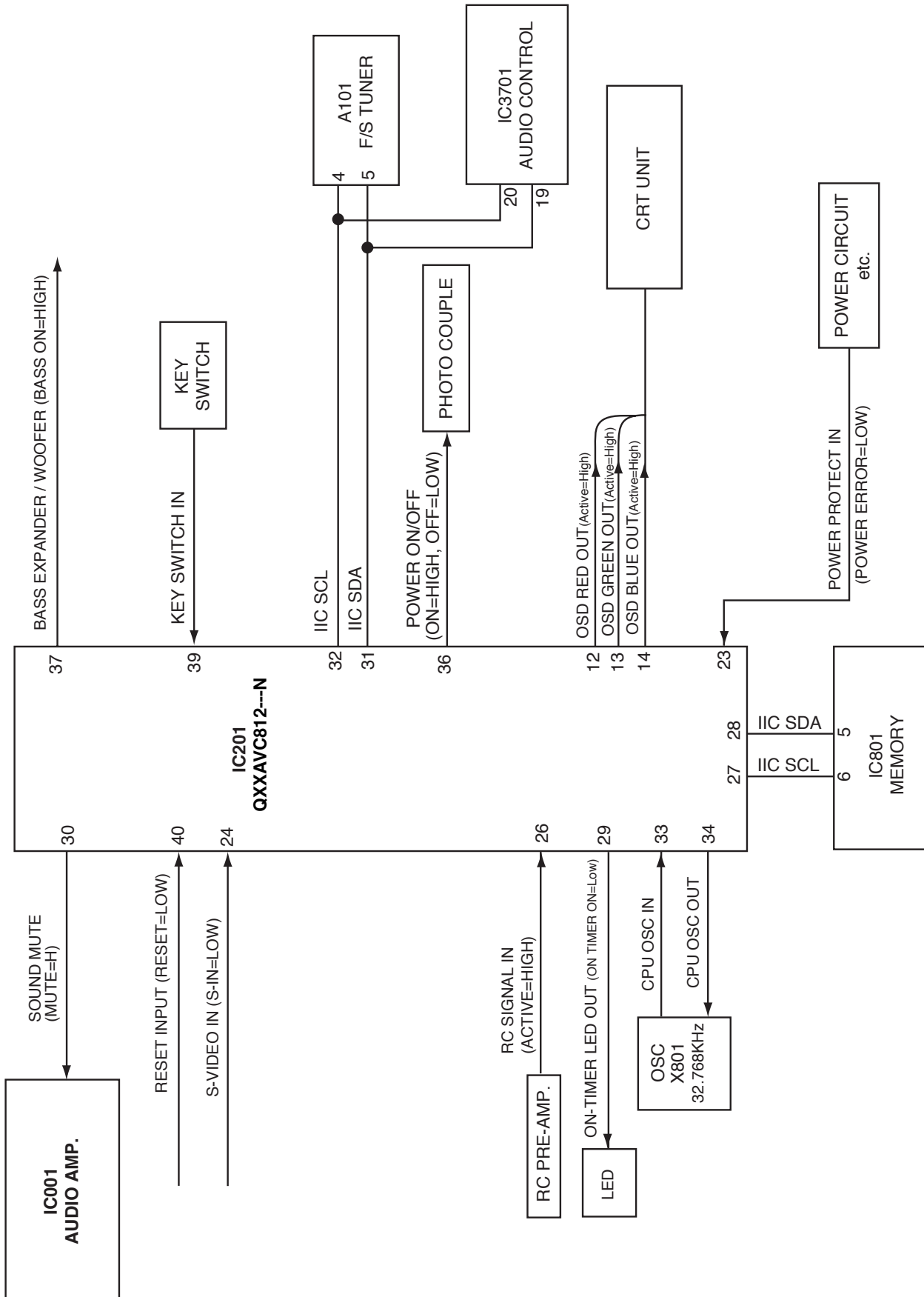

IC Block Diagrams

IC201 < CPU/IF/Video/Chroma/Def. > LA76938NDE56S0-E

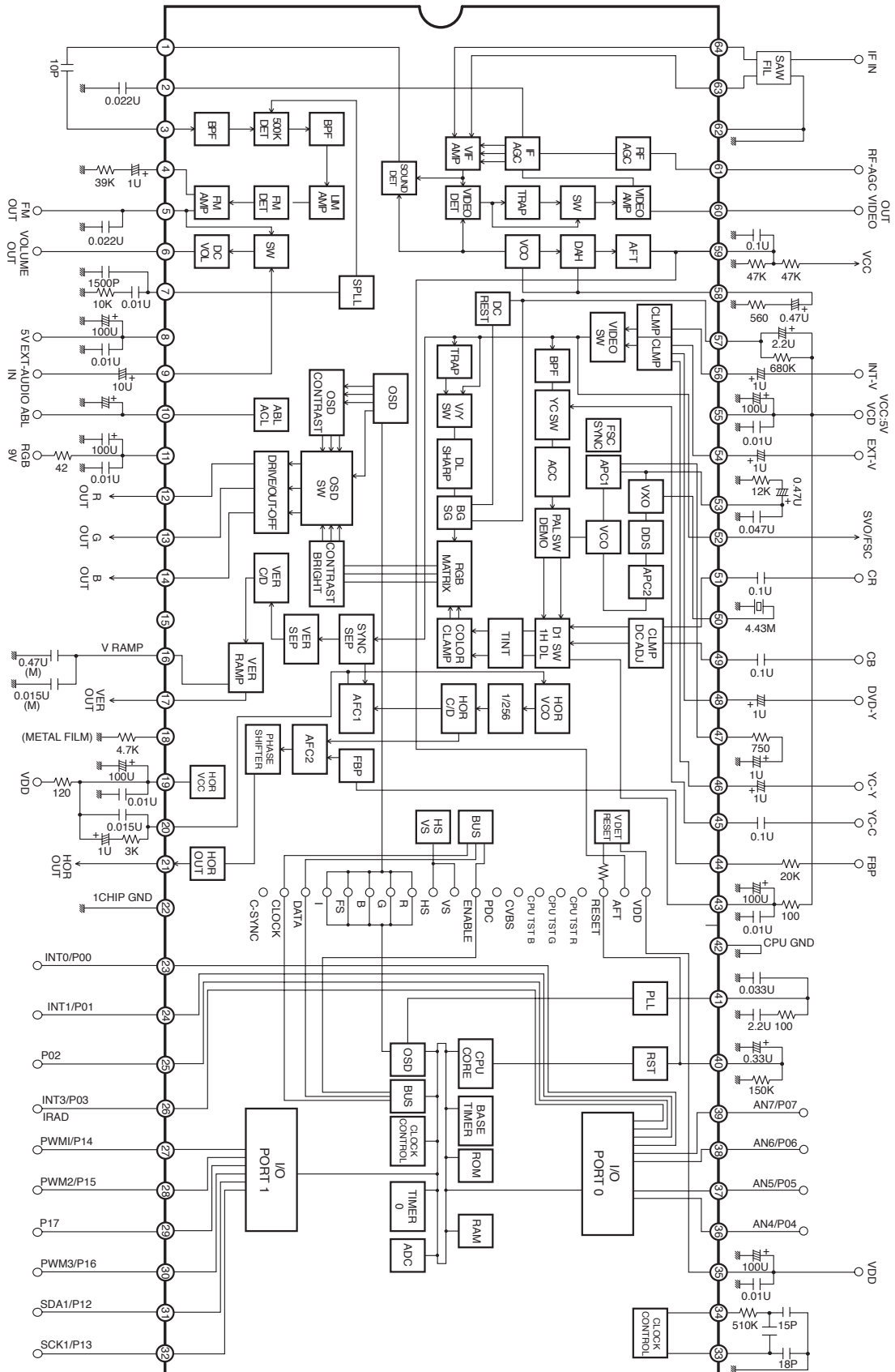

IC Block Diagrams

IC001 < Audio AMP.> TDA8944J/N1

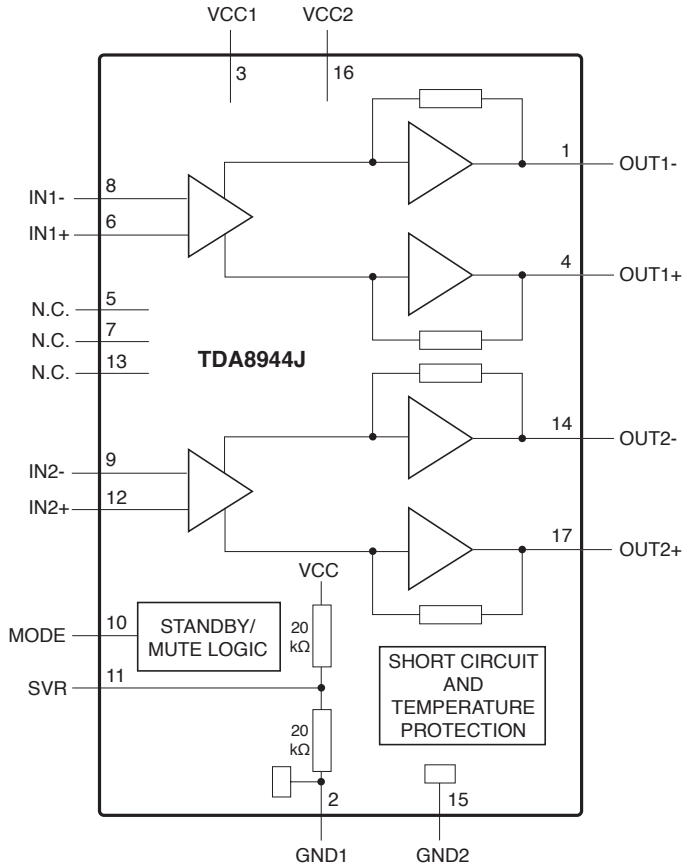

IC501 < Vertical Output >LA78041

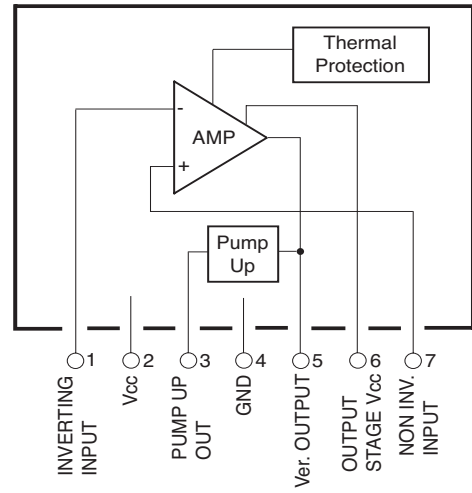

IC3701 < AUDIO Control > LV1116NV-TLM-E

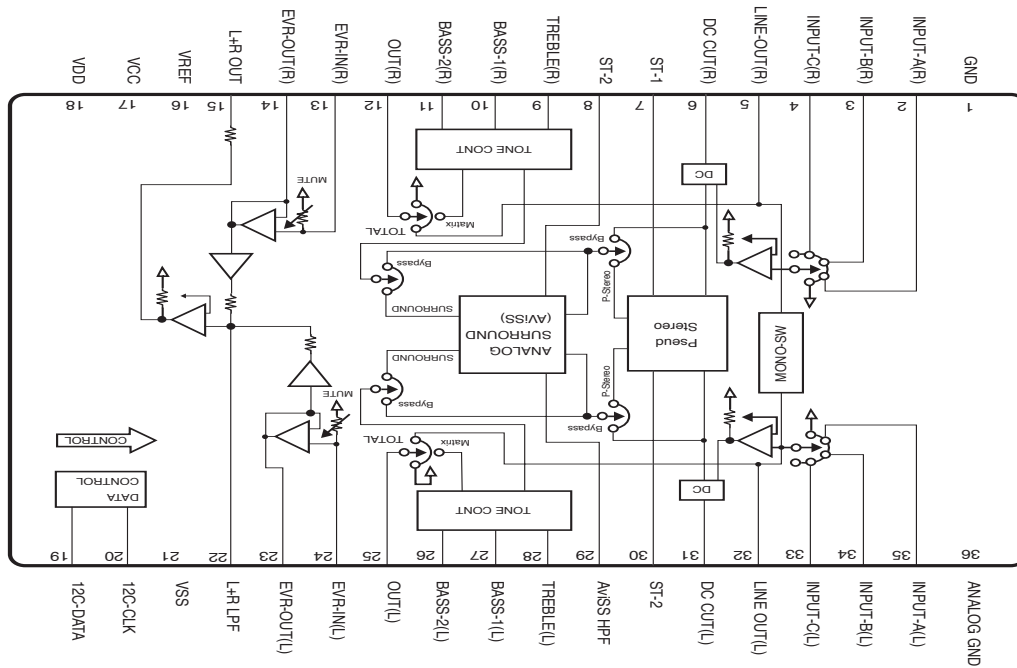

IC201 Port Function

Pin No.	Symbol	Function
1	SIFout	SIF Output (NICAM)
2	IFAGC-F	IF AGC Filter
3	SIF-IN	SIF Input
4	FM-F	Filter for the DC loop of FM detector
5	FMout	FM detector output
6	Audout	Audio output
7	SNDAPCF	Snd VCO frequency is locked at 500kHz from SIF
8	IF-Vcc	DC Supply pin for IF circuit
9	VM/Ext-A-IN	External audio signal input
10	ABL	Auto Beam Limiter function
11	RGB Vcc	Vcc input pin of RGB output block function
12	R-Out	R signal output pin function
13	G-Out	G signal output pin function
14	B-Out	B signal output pin function
15	NC	Not Connected
16	Vramp	To generate a ramp waveform for the reference V-out
17	V-out	Output pin of vertical synchronization ramp signal
18	Iref	Producing reference current function
19	H-Vcc	Vcc of Horizontal deflection and BUS interface
20	AFC-F	AFC Filter pin of horizontal VCO function
21	H-out	Horizontal output pin
22	VCD-GND	Video Chroma Deflection GND
23	Power Fail IN	Power Fail Input function
24	S-TERM IN	S-Video input
25	STATUS IN	Factory PC mode status (L=ON)
26	Remote IN	Remote Control signal receiver
27	P14/PWM1	
28	P15/PWM2	
29	ON-TIMER LED OUT	On timer led out function
30	MUTE OUT	Mute out function
31	IIC SDA1	IIC-Bus Data Line
32	IIC SCK1	IIC-Bus Clock Line
33	X ' tal	Crystal Oscillator
34	X ' tal	Crystal Oscillator
35	5V	Supply (5V)
36	Power Out	Power On/Off signal output
37	Bass Expander ON/OFF OUT	Bass Expander On/Off function
38	VIF M OUT /Bilingual Out	VIF M Out/Bilingual Out function
39	AD KEY IN	Key signal input
40	RESET	RESET pin function
41	FILT	FILT pin function

Pin No.	Symbol	Function
42	GND	Ground
43	CCD-Vcc	Vcc (5V) pin for 1H delay-line
44	FBP-IN	Fly Back Pulse Input
45	YC-C	Y/C-C Input function
46	YC-Y	Y/C-Y Input function
47	C-APC2	AFC filter pin of chroma VCO. (3.58MHz)
48	DVD-Y	DVD-Y Input
49	CB-IN	C _B Input (for DVD)
50	X ' tal	4.43MHz Crystal
51	CR-IN	C _R Input (for DVD)
52	SVO/FSC	Selected Video Output or FSC Output
53	C-APC-F	Chroma APC Filter
54	Ext-Video-IN	Ext Video Input & Y Input in S-VHS mode
55	VCD-Vcc	Video Chroma Deflection VCC
56	Int-Video-IN	Int. Video Input & Chroma Signal Input in S-VHS mode
57	Blk-F	Black peak level detection in black stretch circuit.
58	PIF-APC-F	APC filter pin for PLL circuit function.
59	AFT	Automatic Fine Tuning Output pin
60	Video out	Video Output pin
61	RF AGC	RF AGC Output pin
62	IF-GND	Ground of IF circuit
63	VIF IN	PIF input pin
64	VIF IN	PIF input pin

Service Information

■ Protection Circuit

This TV set has a built-in power supply protection circuit.

It is provided to protect the TV set in case of a power supply circuit malfunctions. When something abnormality occurs during TV reception, the TV set goes to the stand-by mode.

When an abnormality occurs during TV reception, it causes pin 23 of the CPU to go continually Low for about one second. The CPU detects that this has occurred and outputs the signal from pin 36 to switch off the power supply lines.

Releasing the protective circuit and restoring power supply

To release the protective circuit and restore power supply, turn the power to the TV set OFF and then ON again via either the main power switch or the ON-OFF button on the remote control. This will work only if the power supply trouble was temporary. If there is permanent trouble such as a damaged circuit, power cannot be restored and the circuit will have to be repaired.

Service Adjustments with Replacing Memory IC(IC801)

Note: The CPU (IC201) and memory IC (IC801) store the service adjustments data and controls data for each circuit. When the Memory IC(IC801) is replaced, some of the service adjustments should be readjusted to obtain the best performance. The necessary service adjustments are carried out by using the RC handset. Please set up the TV set with following steps [1] to [2].

[1] Initializing Procedure

1. Put a new memory IC.
2. Turn on the TV set.
3. Press and hold the **TV/AV Selector** on the TV set for more than 2 seconds. The following picture appears on the screen.

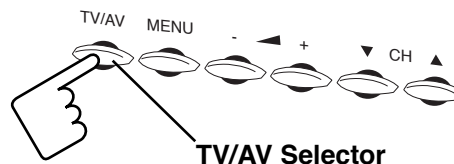
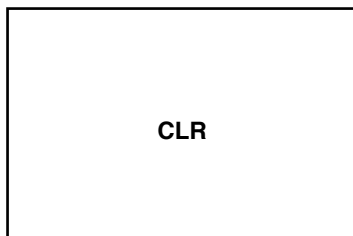

4. Press the **PROGRAMME UP** on the TV set while the above On-Screen Display is still on the screen. The following picture appears on the screen.

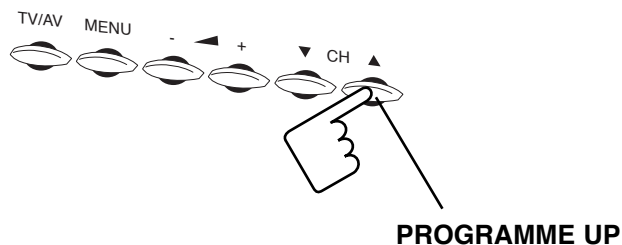

This completes the initialization of memory IC.

Following shows the initialized contents of memory data by this procedure.

- Plug & Play : No executed
- Inhibit Data : Cancelled
- Ch Skip Data : Cancelled
- Sound Volume Data : 10/63 steps.
- Volume Lock : OFF
- Tuning Lock : OFF
- Music Mode : OFF
- AV Start : OFF
- Colour System : AUTO

[2] Required Service Adjustments

Readjust the following service adjustments.

Adjustments	Service Mode No. & Item
RF AGC	Item 01, RF AGC
Horizontal centre	Item 02, H-PHA
Vertical size	Item 05, V-SIZ
Vertical linearity	Item 06, V-LIN
Vertical S-Correction	Item 07, V-SCO
Gray scale	Item 30-33, 35-37

Further adjustment please refer to page 14 and 15.

Service Adjustments with Replacing Memory IC(IC801)

Following table shows the initial values which have been stored in the CPU ROM, and items for the service adjustments.

Service mode adjustments table in CPU ROM

No.	ITEM	DATA RANGE	INITIAL SETUP DATA	DESCRIPTION
01	RFAGC	0~63	27	RF AGC Adj.
02	H-PHA	0~31	10	H-Phase (H-Centering) Adj. (50Hz)
03	V-POS	0~63	40	V-Position (V-Centering) Adj. (50Hz)Fixed.
04	V-SHIFT	0~15	5	V-Phase Adj. (50Hz)
05	V-SIZ	0~127	72	V-Size Adj. (50Hz)
06	V-LIN	0~31	16	V-Linearity Adj. (50Hz)
07	V-SCO	0~31	18	Vertical S-Correction Adj. (50Hz)
08	V-TRANS	0~1	0	Data transmission between V Retrace
09	V-RES	0~1	0	Vertical Reset Timing.
10	H-P60	-16~+15	+3	H-Phase Adj. (60Hz) difference val.
11	V-S60	-64~+63	0	V-size Adj. (60Hz) difference val.
12	V-SHIF60	-16~+15	-3	V-Phase Adj. (60Hz) difference val.
13	OSDHP	0~255	20	OSD H-Position Adj.
14	OSDC	0~7	4	OSD Contrast Adj.
15	V-SCP	0~7	7	V-Size COMP Adj.
16	H-SCP	0~7	7	H-Size COMP Adj.
17	EWDC	0~63	44	H-Width / H-Size adj.
18	EWAMP	0~63	25	EW Parabola / Width ratio
19	EWILT	0~63	30	EW Trapezium correction
20	EWTOP	0~15	10	EW Corner Top
21	EWBTM	0~15	10	EW Corner Bottom
22	EWCFNSW	0~3	0	Select control range for corner corr.
23	EWTEST	0~7	0	Select EW DAC test mode
24	EWDC60	-32~+31	+1	H-Width / H-Size Adj. NTSC (60Hz)
25	EWAMP60	-32~+31	0	EW Parabola/Width ratio NTSC (60 Hz)
26	EWILT60	-32~+31	0	EW Trapezium correction NTSC (60 Hz)
27	EWTOP60	-16~+15	0	EW Corner Top NTSC (60Hz)
28	EWBTM60	-16~+15	0	EW Corner bottom NTSC (60Hz)
29	SBIAS	0~255	105	Sub Bias Adj.
30	RBIAS	0~255	0	Red Bias Adj.
31	GBIAS	0~255	0	Green Bias Adj.
32	BBIAS	0~255	0	Blue Bias Adj.
33	RDRIV	0~127	64	Red Drive Adj.
34	GDRIV	0~15	8	Green Drive Adj.
35	BDRIV	0~127	64	Blue Drive Adj.
36	1 Line Appear			White Balance Adj.
37	DRV			White Balance Adj.
38	B-YD	0~31	29	B-Y DC Level
39	R-YD	0~31	26	R-Y DC Level
40	B-YDN	-16~+15	0	NTSC B-Y DC Level Adj.
41	R-YDN	-16~+15	0	NTSC R-Y DC Level Adj.
42	SBDC	-16~+15	-2	SECAM B-Y DC Level Adj.
43	SRDC	-16~+15	-10	SECAM R-Y DC Level Adj.
44	B-YDD	-16~+15	-14	DVD B-Y DC Level
45	R-YDD	-16~+15	-17	DVD R-Y DC Level

No.	ITEM	DATA RANGE	INITIAL SETUP DATA	DESCRIPTION
46	RGBTEMP	0~1	0	RGB Temp. SW
47	RGBTEST	0~1	0	RGB Test
48	EXTRGBC	0~1	0	External RGB Contrast
49	RGBTEST	0~1	0	RGB Test
50	HALFTONE	0~3	0	Halftone Color
51	G-YA	0~1	0	G-Y Angle
52	GYAMP	0~15	8	G-Y Amplitude Adj.
53	RBBG	0~15	8	R-Y / B-Y Gain Balance
54	RBAG	0~15	8	R-Y / B-Y Angle
55	G-YAN	0~1	0	NTSC G-Y Angle
56	GYAMPN	-8~+7	0	NTSC G-Y Amplitude Adj.
57	RBBGN	-16~+15	0	NTSC R-Y / B-Y Gain Balance
58	RBAGN	-16~+15	0	NTSC R-Y / B-Y Angle
59	RBBGDN	-16~+15	+10	DVD NTSC R-Y / B-Y Gain Balance
60	RBAGDN	-16~+15	+10	DVD NTSC R-Y / B-Y Angle
61	VOLFIL	0~1	0	DAC Volume filter disable
62	APCOFFSET	0~1	0	Align APC Offset Current
63	IF-AGC	0~1	0	IF AGC defeat
64	OVERMOD	0~1	0	Select Over Modulation Circuit Type
65	COGV	0~3	0	Coring Gain
66	BLKS	0~3	3	Blk. Str. Start (w/ defeat)
67	BLKG	0~3	3	Blk. Str. Gain
68	BRTA	0~1	0	Brt. Abl. Def.
69	BRST	0~1	0	Mid. Stp. Def.
70	BRTH	0~7	0	Bright Abl. Threshold
71	WPL	0~3	2	White Peak Limit Op. Point (w/ defeat)
72	YGAM	0~3	0	Y Gamma Start
73	PRS	0~3	0	Pre-shoot AV Adj.
74	ORS	0~3	0	Over-shoot AV Adj.
75	DCREST	0~3	0	Select Luminance DC Restoration
76	RFCO	0~3	1	RF Coring Gain Difference
77	PRSN	0~3	0	Pre-shoot RF Adj.
78	ORSN	0~3	3	Over-shoot RF Adj.
79	CTRAP	0~7	4	Chroma Trap control
80	CBPF	0~3	0	Chroma BPF control
81	CBPFN	0~3	1	Chroma BPF control NTSC
82	CBPFAVN	0~3	0	Chroma BPF control AV NTSC
83	TINT	-16~+15	0	Tint RF
84	TINT443	-16~+15	+4	Tint (NTSC4.43)
85	SHRF	-32~+31	0	RF Sharpness
86	SH Adj	-32~+31	0	Sharpness Adjustment
87	COL TEST	0~1	0	Color Test
88	COL NTSC	-32~+31	-20	Color NTSC (difference from PAL)
89	CODP	-16~+15	-5	DVD PAL Color
90	CODN	-16~+15	-20	DVD NTSC Color

Service Adjustments with Replacing Memory IC(IC801)

No.	ITEM	DATA RANGE	INITIAL SETUP DATA	DESCRIPTION
91	TINTDN	-16~+15	-7	DVD NTSC Tint
92	YTH	0~3	0	Select Y signal sensitivity for Blue Strech
93	YGAIN	0~3	0	Select Blue stretching gain w/ defeat
94	RWIDTH	0~3	0	R Width
95	ROFFSET	0~3	0	R Offset
96	BWIDTH	0~3	0	B Width
97	BOFFSET	0~3	0	B Offset
98	VOLUM	0~127	127	Volume Control
99	DEEM	0~1	0	De-emphasis TC
100	VIFSW	0~3	0	VIF System SW
101	SIFSW	0~3	1	SIF System SW
102	V-LVL	0~7	4	Video Level
103	V-LVLOFS	0~3	1	Video Level Offset
104	FMGAIN	0~1	0	FM Gain
105	IFOM-S	0~1	0	Over Modulation SW
106	IFMN-S	0~1	1	Audio Monitor SW Monitor or FM
107	IFTRPS	0~1	1	IC Inside SIF Trap SW ON-OFF
108	IFMLVL	0~15	0	IF Over Modulation Level Adj.
109	IFTEST1	0~1	0	IF Test 1
110	TRAPT	0~7	4	Sound Trapt Test
111	H-FRQ	0~63	20	Horizontal Freq.
112	FBTS	0~1	0	FBPBLK SW
113	COOP	0~7	7	Color Killer Option
114	HBLKL	0~7	6	H-Blanking Control Left
115	HBLKR	0~7	3	H-Blanking Control Right
116	AFCRF	0~1	0	RF AFC Gain & Gate Adj.
117	VSURF	0~1	0	RF Vsync. Separation sensitivity
118	CDMRF	0~7	0	RF Vertical count down circuit Adj.
119	AFCAV	0~1	1	AV AFC Gain & Gate Adj.
120	VSUAV	0~1	0	AV Vsync separation sensitivity
121	CDMAV	0~7	0	AV vertical count down circuit Adj.
122	HLVDRF	0~1	1	H-Lock Vdet
123	HLVDAV	0~1	1	H-Lock Vdet
124	VTEST	0~3	0	Select Vertical DAC test mode
125	VCO ADJ	0~15	8	IF VCO free run Freq. Adj.
126	C.VCOADJ	0~7	4	Control free run Freq. of chroma VCD
127	VCOFREQ	0~255	100	ES Sample IF VCO Freq. Adj.
128	CROSS-BW	0~3	0	Pattern Output
129	AVNCON	0~127	64	AV non-signal Contrast
130	AVNBRI	0~127	64	AV non-signal Brightness
131	VMDELAY	0~3	0	Select Delay of VM out
132	VMGAIN	0~7	0	Select VM Gain of VM out
133	SYNSEP	0~7	4	Select Sync. Sep Treshold Level
134	SCMKILON	0~1	0	Enable Killer Circuit (Service Mode only)
135	SCMKILOF	0~1	0	Disable Killer Circuit (Service Mode only)

No.	ITEM	DATA RANGE	INITIAL SETUP DATA	DESCRIPTION
136	SCM TEST	0~1	0	SECAM DC Level Adj.
137	BELL SW	0~1	1	Enable BELL Filter Adj.
138	EQU SW	0~1	0	Enable EQUALIZER Circuit Adj.
139	BELLADJ	0~15	3	BELL Filter Adj.
140	EQU ADJ	0~15	0	EQUALIZER Filter Adj.
141	POMT	0~127	25	Power Mute Time
142	CHMT	0~31	8	Ch Mute Time
143	SYST	0~15	5	System
144	S-STE	0~3	1	AV Stereo/Mono Option
145	VOLTBL	0~1	1	Volume Table Select
146	MPP	0~1	0	MPP Function on/off Option
147	TUNER	0~1	0	Tuner Option
148	BOOSTER	0~1	0	Booster Option (LNA Tuner)
149	OPT AVIN	0~3	1	AV1/AV2/AV3 Option
150	OPT POS	0~1	1	255 Position Option
151	LANGUAGE	0~1	1	Language Option
152	OPT COL	0~1	1	Color System Option
153	OPT SIF	0~1	1	SIF System Option
154	OPT BASS	0~3	2	Bass Expander Option
155	OPT SURR	0~1	1	Surround Option
156	OPT BLBK	0~1	1	Blue Back Option
157	1LINEMOD	0~1	0	Color Output Data Option at 1 Line Mode
158	OPT VM	0~1	0	Select VM Out or Ext Audio In
159	OPT ERGB	0~1	1	Select Video In or RGB In
160	AUDGAIN	0~7	1	Gain Control LV1116
161	L/RGAIN	0~7	6	L/R Output Gain Control LV111
300	R00	0~255	82	ROM Correction
301	R01	0~255	244	ROM Correction
302	R02	0~255	84	ROM Correction
303	R03	0~255	249	ROM Correction
304	R04	0~255	173	ROM Correction
305	R05	0~255	101	ROM Correction
306	R06	0~255	0	ROM Correction
307	R07	0~255	0	ROM Correction
308	R08	0~255	7	ROM Correction
309	R09	0~255	19	ROM Correction
310	R10	0~255	2	ROM Correction
311	R11	0~255	136	ROM Correction
312	R12	0~255	224	ROM Correction
313	R13	0~255	3	ROM Correction
314	R14	0~255	33	ROM Correction
315	R15	0~255	82	ROM Correction
316	R16	0~255	246	ROM Correction
317	R17	0~255	33	ROM Correction

Notes: The initial value that the CPU writes down the CPU ROM data to the memory when replaced the memory IC. TV set may not operate correctly with this initial value. It is required to set up the fine adjustment for service adjustments described in the above.

Service Adjustments with Replacing Memory IC(IC801)

No.	ITEM	DATA RANGE	INITIAL SETUP DATA	DESCRIPTION
318	R18	0~255	83	ROM Correction
319	R19	0~255	1	ROM Correction
320	R20	0~255	0	ROM Correction
321	R21	0~255	0	ROM Correction
322	R22	0~255	0	ROM Correction
323	R23	0~255	0	ROM Correction
324	R24	0~255	34	ROM Correction
325	R25	0~255	153	ROM Correction
326	R26	0~255	100	ROM Correction
327	R27	0~255	33	ROM Correction
328	R28	0~255	173	ROM Correction
329	R29	0~255	85	ROM Correction
330	R30	0~255	0	ROM Correction
331	R31	0~255	0	ROM Correction
332	R32	0~255	0	ROM Correction
333	R33	0~255	0	ROM Correction
334	R34	0~255	0	ROM Correction
335	R35	0~255	0	ROM Correction
336	R36	0~255	0	ROM Correction
337	R37	0~255	0	ROM Correction
338	R38	0~255	0	ROM Correction
339	R39	0~255	0	ROM Correction
340	R40	0~255	0	ROM Correction
341	R41	0~255	136	ROM Correction
342	R42	0~255	224	ROM Correction
343	R43	0~255	4	ROM Correction
344	R44	0~255	223	ROM Correction
345	R45	0~255	0	ROM Correction
346	R46	0~255	1	ROM Correction
347	R47	0~255	2	ROM Correction
348	R48	0~255	255	ROM Correction
349	R49	0~255	0	ROM Correction
350	R50	0~255	33	ROM Correction
351	R51	0~255	84	ROM Correction
352	R52	0~255	251	ROM Correction
353	R53	0~255	0	ROM Correction
354	R54	0~255	0	ROM Correction
355	R55	0~255	0	ROM Correction
356	R56	0~255	0	ROM Correction
357	R57	0~255	0	ROM Correction
358	R58	0~255	0	ROM Correction
359	R59	0~255	0	ROM Correction
360	R60	0~255	0	ROM Correction
361	R61	0~255	0	ROM Correction
362	R62	0~255	0	ROM Correction

No.	ITEM	DATA RANGE	INITIAL SETUP DATA	DESCRIPTION
363	R63	0~255	0	ROM Correction
364	R64	0~255	0	ROM Correction
365	R65	0~255	0	ROM Correction
366	R66	0~255	0	ROM Correction
367	R67	0~255	0	ROM Correction
368	R68	0~255	0	ROM Correction
369	R69	0~255	0	ROM Correction
370	R70	0~255	0	ROM Correction
371	R71	0~255	0	ROM Correction
372	R72	0~255	0	ROM Correction
373	R73	0~255	1	ROM Correction
374	R74	0~255	205	ROM Correction
375	R75	0~255	0	ROM Correction
376	R76	0~255	0	ROM Correction
377	R77	0~255	109	ROM Correction

Service Adjustments with Replacing Memory IC(IC801)

[Entering to Service Mode]

1. Press and hold the **MENU** button on the Remote Control and press the **VOLUME (+)** button on the TV set. Following setting items appears on the screen.

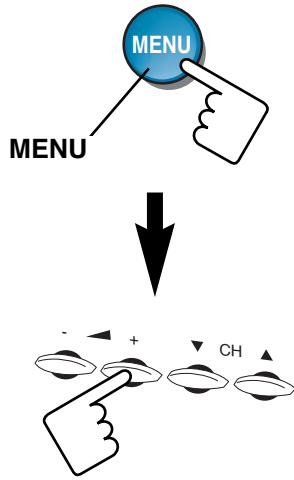

Display for [RF AGC] RF AGC adjustment

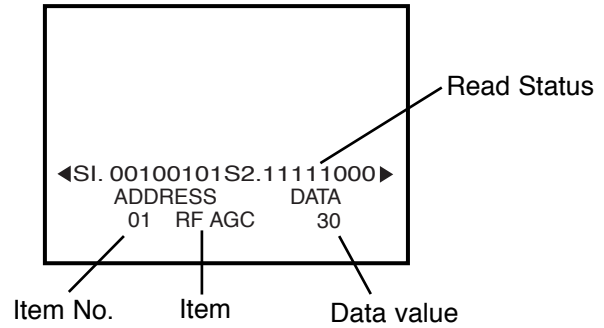

2. Select item by pressing the **TIMER** (Item No. UP) or **SOUND MUTE** (Item No. DOWN) button on the remote control handset.

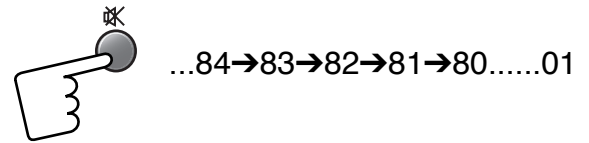
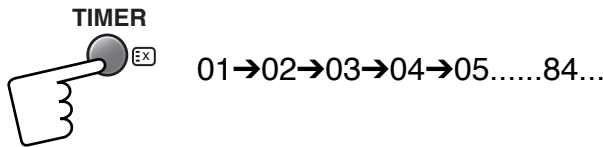

Example

Display for [V-SCO] V-S Correction adjustment

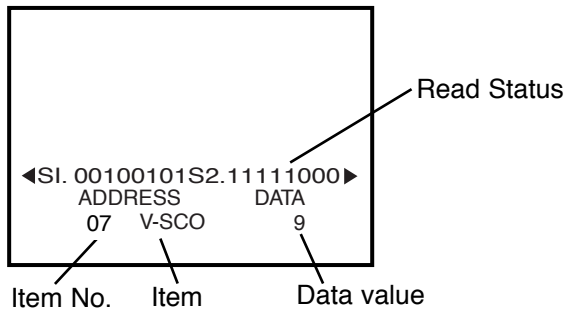

Display for [DRV] White balance adjustment

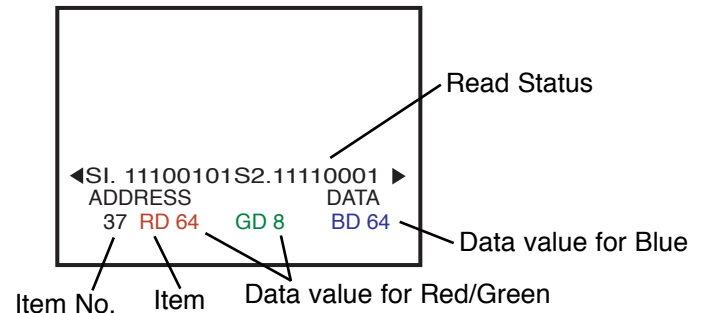

3. Adjust data value by pressing the **VOLUME +** or **VOLUME -** button on the remote control handset.

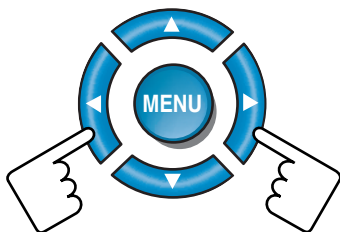

To return to normal TV mode, press the **MENU** button on the TV set or the remote control handset.

Service Mode Adjustments

Following adjustments should be carried out when the memory IC is replaced. How to enter the service mode and adjust values, please refer to "Entering to Service mode" on page 13.

Item 01 [RF AGC] AGC

NOTE: Do not attempt this adjustment with weak signal.

- (1) Tune the receiver to most clearest (or strongest) VHF station in your area. Set the brightness and contrast controls to maximum. Set the colour control to minimum.
- (2) Select [RF AGC] in the service mode.
- (3) Change value until the snow noise just disappears.
- (4) Exit from service mode.

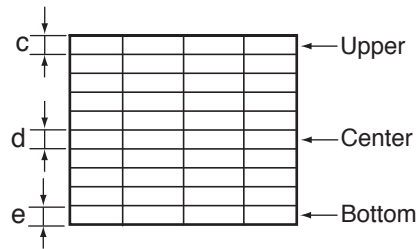

Item 02 [H-PHA] HORIZONTAL CENTRE

- (1) Receive a monochrome circular pattern.
- (2) Set the brightness and contrast to normal.
- (3) Select [H-PHA] in the service mode.
- (4) Change value to be optimum horizontal centre position.
- (5) Exit from service mode.

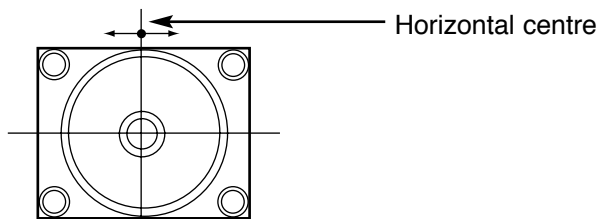

Item 05 [V-SIZ] VERTICAL SIZE

- (1) Receive a monochrome circular pattern.
- (2) Set the brightness and contrast to maximum.
- (3) Select [V-SIZ] in the service mode.
- (4) Change value to be optimum vertical size.
- (5) Exit from service mode.

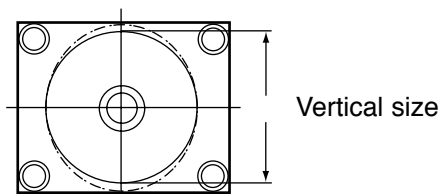

Item 07 [V-SCO] V-S CORRECTION

- (1) Receive a crosshatch pattern.
- (2) Select a picture mode of NATURAL by pressing the PICTURE MODE button.
- (3) Select [V-SCO] in the service mode.
- (4) Adjust Vertical S-letter Correction so that the difference of "c", "d" and "e" becomes less than 2 mm by pressing the VOLUME + or - button.
- (5) Confirm Vertical Linearity and adjust Vertical Center then Vertical Size.
- (6) Exit from service mode.

Item 06 [V-LIN] VERTICAL LINEARITY

- (1) Receive a crosshatch pattern.
- (2) Select a picture mode of NATURAL by pressing the PICTURE MODE button.
- (3) Select [V-LIN] in the service mode.
- (4) Adjust Vertical Linearity so that the difference of "a" and "b" becomes less than 3mm by pressing VOLUME + or - button.
- (5) Exit from service mode.

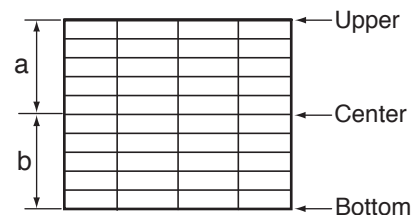

Item 18~21 [PCC] PCC Adjustment

- (1) Receive a crosshatch pattern.
- (2) Select a picture mode of NATURAL by pressing the PICTURE MODE button.
- (3) Select [EWAMP] in the service mode.
- (4) Adjust Vertical Lines to be adequately straight.
- (5) Select [EWTILT] in the service mode.
- (6) Adjust Vertical Lines to be adequately parallel each other.
- (7) Select [EWTOP] in the service mode.
- (8) Adjust Left and Right top corner so that vertical lines more straight.
- (9) Select [EWBTM] in the service mode.
- (10) Adjust Left and Right bottom corner so that vertical lines more straight.

Service Mode Adjustments

Items 30-33, 35-37 GREY SCALE

- (1) Receive a monochrome circular pattern.
- (2) Set the brightness and colour to normal, contrast to maximum.
- (3) Enter to the service mode.
- (4) Select No. 30 RBIAS (Red Bias), No. 31 GBIAS (Green Bias), and No. 32 BBIAS (Blue Bias) and set each data to 0 by pressing the VOLUME + or - key.
- (5) Select No. 33 RDRIV (Red Drive) and No. 35 BDRIV (Blue Drive) and set each data to 64 by pressing the VOLUME + or - key.
- (6) Turn Screen Control on the FBT (T471) to minimum (fully counter-clock-wise).
- (7) Select No. 36 (1-line appear).
- (8) Advance Screen Control clockwise to obtain just visible one colour line. If line does not appear, place this control to maximum (fully clockwise).
- (9) Raise each Bias Level with 1, 2, 5, 6, 9 and 0 keys to obtain just visible white line.
- (10) Select No. 37 DRV (Drive Adjustments).
- (11) Adjust Red and Blue Drive Levels alternately with 3, 4, -/-- or RECALL key to produce normal black and white picture in highlight areas.
- (12) Check for proper grayscale at all brightness levels. To turn off the TV Service Menu display, press the MENU key.

Note: If the Grayscale adjustment is made after picture tube replacement, check the High Voltage

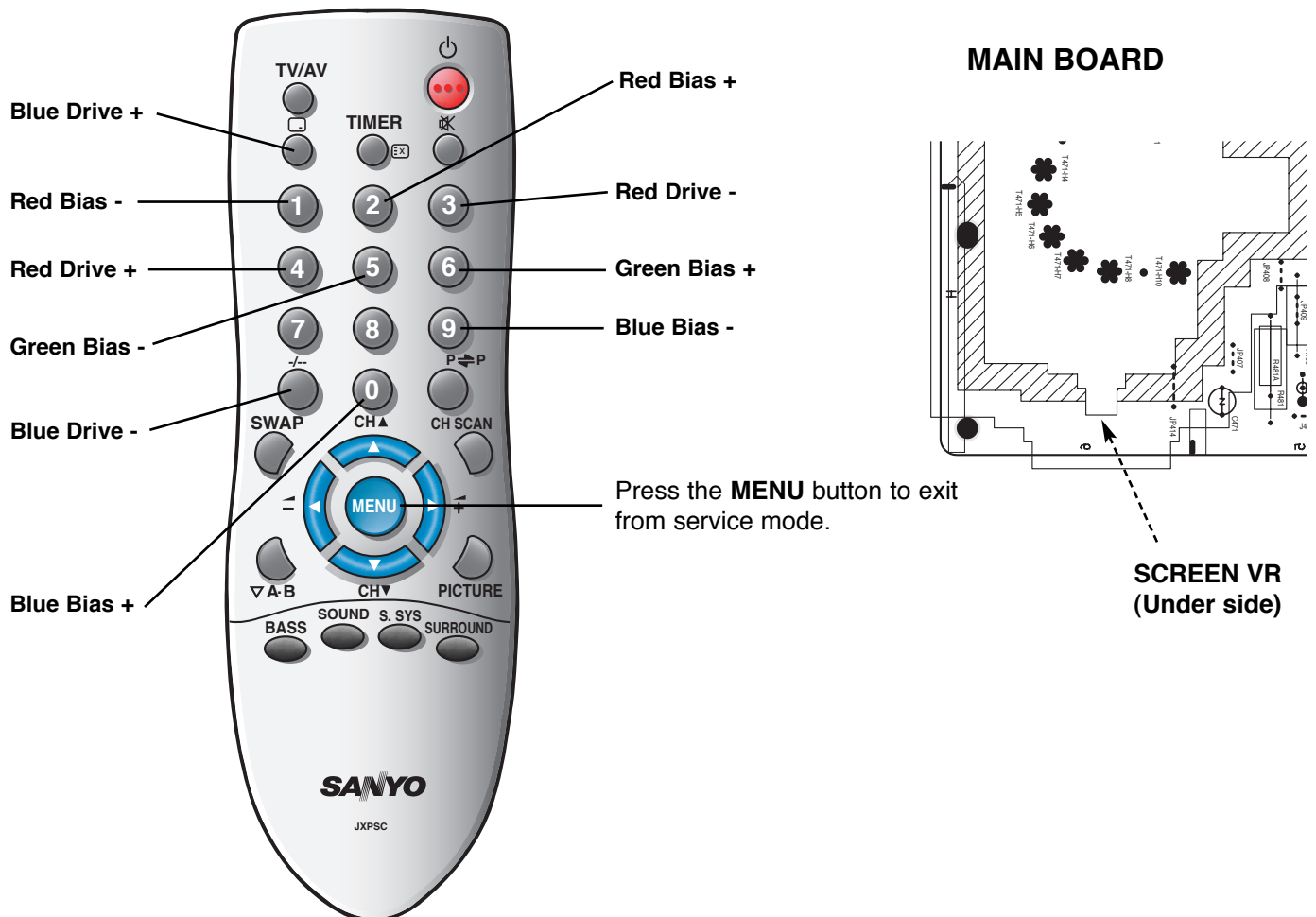

Service Adjustments

Following adjustments are not required to readjust when replacing the memory IC.

B-VOLTAGE SUPPLY CHECKING

- (1) Connect DC meter to TP-B and the ground.
- (2) Tune the receiver to an active channel and synchronized picture. Select NATURAL picture mode by pressing the **PICTURE MODE** button on the remote control.
- (3) Adjust B-voltage to be $140 \pm 0.5V$ DC by using VR631.

HIGH VOLTAGE CHECK

Note: +B (+140V) Voltage Check and Grayscale Adjustment must be completed before attempting High Voltage Check.

- (1) Connect high voltage voltmeter negative lead to ground, and connect + lead to anode of picture tube.
- (2) Tune receiver to an active channel and confirm TV is operating properly.
- (3) Maximize the beam current by adjusting the contrast and brightness controls to maximum. Confirm high voltage is within 28.0 KV and 30.0 KV at maximum beam current.
- (4) Eliminate the beam current by adjusting the contrast and brightness controls to minimum. Confirm high voltage does not exceed 31.5 KV at zero beam current.

If reading is not within range, check horizontal circuit.
No high-voltage adjustment is provided on this chassis.

MAIN BOARD

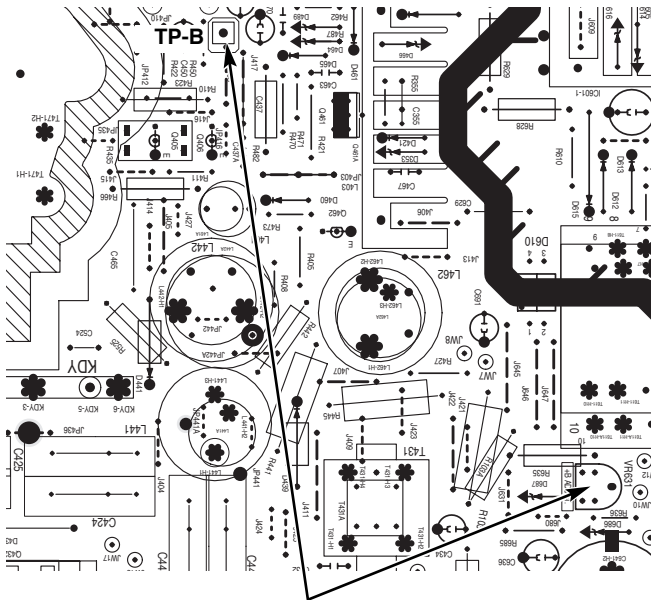

B-Voltage Supply Adjustment

FOCUS ADJUSTMENT

- (1) Receive the monochrome circular pattern.
- (2) Set the brightness to normal and contrast to maximum.
- (3) Adjust the focus control on the F.B.T. for the best focus on the screen centre.

MAIN BOARD

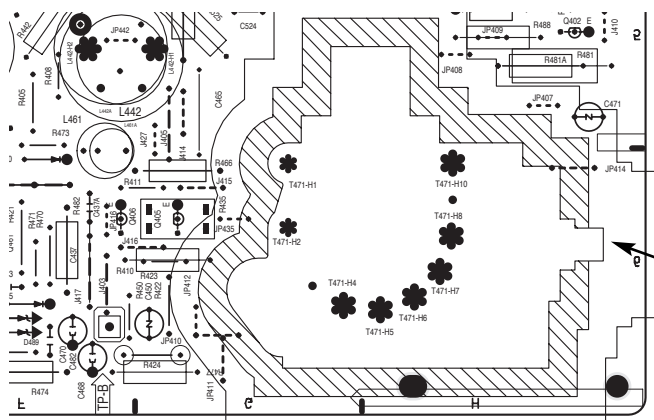

Special Function

The following special functions can be set up on this TV set.

(1) Volume Lock setting

With this function, a maximum sound volume limit can be set at any level.



(2) Tuning Lock setting

Once TUNING LOCK is switched on, further channel tuning (Pre-set) is not possible. The Channel Swapping function also is not possible.



(3) Music Mode setting

When Music Mode is ON, Programme position from "247" to "255" and "0" are set Music Mode. Only sound is provided and any picture is not on the screen under Music Mode.

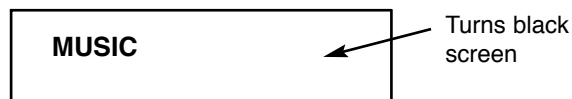

(4) AV Start setting

Set AV-START to ON and every time the TV set is switched on, AV1 position will be the initial programme position.



How to set the special function:

Note: When making the VOLUME LOCK setting, set the desired maximum sound volume by pressing the **VOLUME +** or **-** button before entering Special Function setting mode.

- 1 To enter into the special function setting mode, press and hold the **MENU** button of the remote control, then press the **PROGRAMME DOWN** button on the TV set.

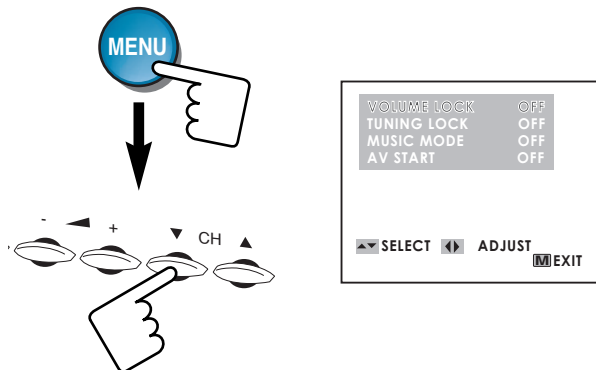

- 2 Select an item of the special functions by pressing the **PROGRAMME UP** or **DOWN** button on the remote control or the TV set.

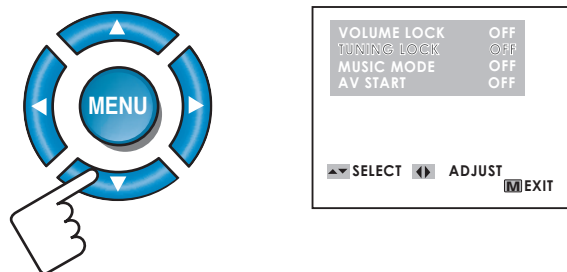

- 3 Set the selected special function "ON" by pressing the **VOLUME +** or **-** button. To cancel, set to "OFF".

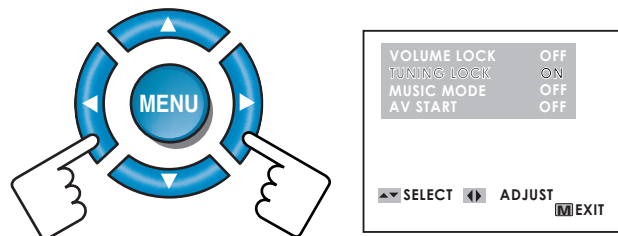

- 4 Press the **MENU** button of the remote control to return to the normal TV mode.

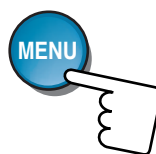

Purity and Convergence Adjustment

CAUTION: The Convergence and Purity adjustments have been made at the factory. Readjustment should be made only after picture tube or deflection yoke replacement, following the steps below:

Signals: Use a pattern generator which can output red, green, blue and white raster and crosshatch pattern signals.

Procedure: Carry out purity adjustment first, and then carry out convergence adjustment.

Preparation: The deflection yoke may have several correction magnets attached to its outer edge. If replacing the picture tube, the positions of the magnets can be changed and they can be re-used, so remove these magnets and keep them safely so that they do not get lost.

PURITY ADJUSTMENTS

1. Place the picture so that its front faces west.
2. Insert the power plug into a wall outlet, and then turn on the power for the TV and de-magnetize the TV using its own degaussing circuit.
3. Loosen the screw which is holding the deflection yoke (with integrated purity magnets), and then move the deflection yoke forward as far as it will go. Remove the rubber wedge at this time.
4. Turn off the red and blue raster so that only the green raster is on.
5. Adjust the angle between the tabs (wings) on purity magnets to center the vertical green belt in the picture tube screen. (See Figures 2 and 3.)

NOTE: This adjustment can only be carried out by changing the angle, not by rotating the tabs up and down.

6. Gently move the deflection yoke back to the position where the green band fills the whole of the picture tube screen, and then tighten the screw to secure the deflection yoke in place.
7. If there is any color distortion around the edges, correct it by attaching magnets to the outer edge of the deflection yoke. The magnets should be attached so that the line running from the position of the distortion to the center of the picture tube intersects the deflection yoke. The colors on the magnets indicate the north and south poles of the magnets. Attach the magnets in whichever direction causes the distortion to disappear. (See Figures 1 and 4. The south and north pole positions are shown as a guide.)
8. Switch the screen to red and blue rasters and check that there is no color distortion. If there is any distortion, adjust the angles of purity magnets tabs or the forward-back position of the deflection yoke, or change the attachment positions of the correction magnets.

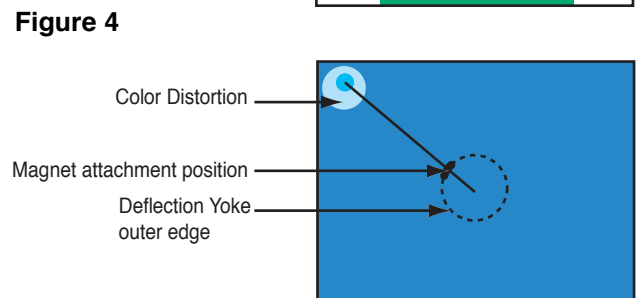
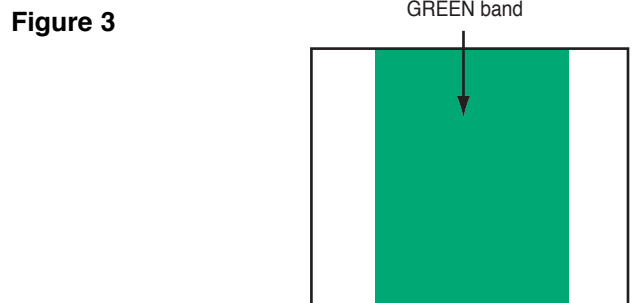
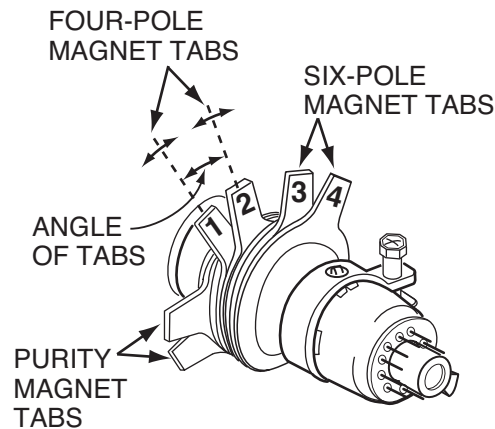
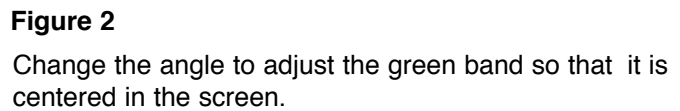
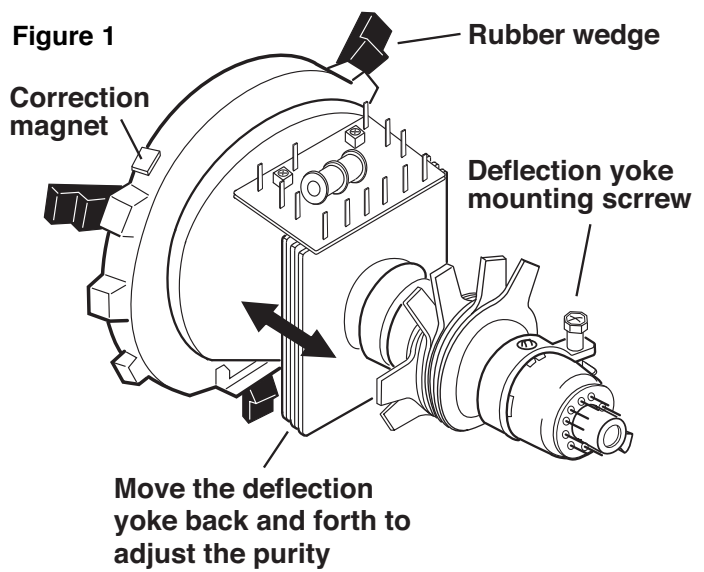
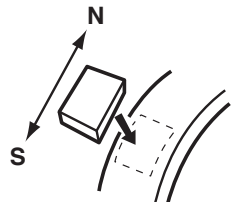

Purity and Convergence Adjustment

CONVERGENCE ADJUSTMENT

Preparation: After carrying out purity adjustment and before proceeding to convergence adjustment, provisionally insert the rubber wedge so that there is no vertical or sideways play in the deflection yoke.

Signals: Display a crosshatch pattern.

1. Red/blue center adjustment

Adjust the angle between the tabs (1) and (2) in Figure 5 and rotate them together until the lines of the red and blue crosshatch patterns (vertical and horizontal lines) are superimposed in the center of the screen.

2. Green and red/blue center adjustment

Adjust the angle between the tabs (3) and (4) in Figure 5 and rotate them together until the lines of the green crosshatch pattern are superimposed with the red/blue crosshatch pattern (vertical and horizontal lines) which were superimposed in step 1).

3. Vertical lines at screen center (Red and Blue)

Use the VR2 control (see Figure 8) at the top of the deflection yoke to correct the vertical line convergence at the center of the screen. (See Figure 9.)

4. Vertical lines at screen top and bottom

Use the VR1 control (see Figure 8) at the top of the deflection yoke to correct the vertical line convergence at the top and bottom of the screen. (See Figure 10.)

5. Horizontal lines at screen top and bottom

Rotate the Deflection yoke to the left or right to correct the horizontal line convergence at the top and bottom of the screen. (See Figure 11.)

If vertical lines are intersecting at the top and bottom, use a screwdriver to adjust the Balance coil at the top of the deflection yoke. (See Figure 12.)

Figure 8

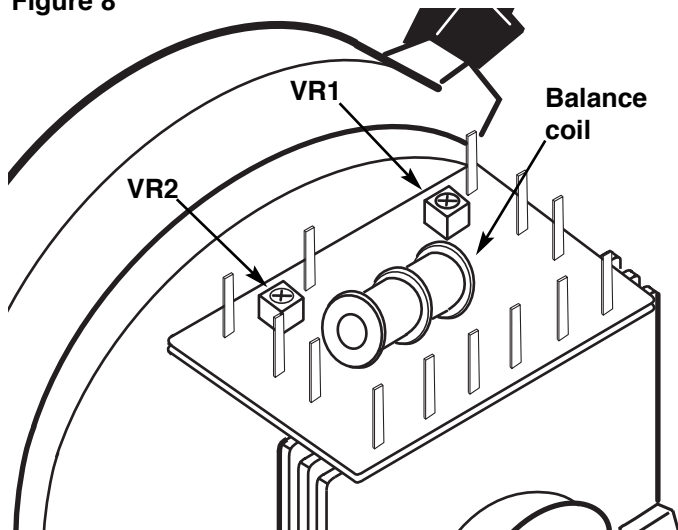

Figure 5

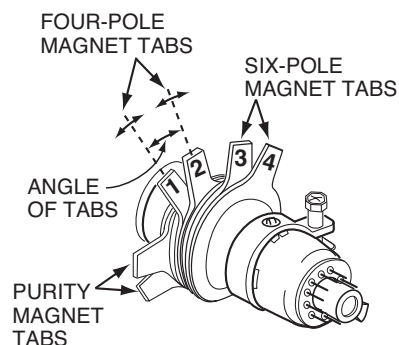
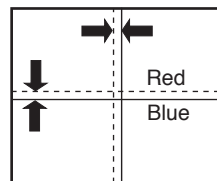
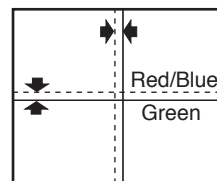

Figure 6



Adjust the angle rotation of tabs (1) and (2) to align the vertical and horizontal lines.

Figure 7



Adjust the angle and rotation of tabs (3) and (4) to align the vertical and horizontal lines.

Figure 9

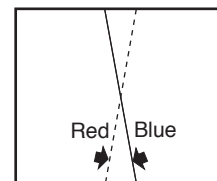

Use the VR2 control to correct.

Figure 10

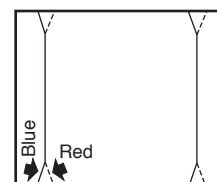

Use the VR1 control to correct.

Figure 11

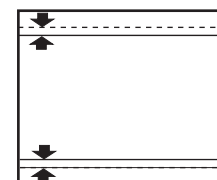

Rotate the DY to correct.

Figure 12

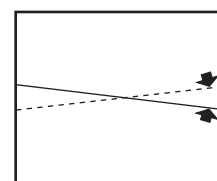

Use the Balance coil to correct

Cabinet Parts List

BA4H

Note: Parts order must contain Service Ref. No., Part No., and descriptions.

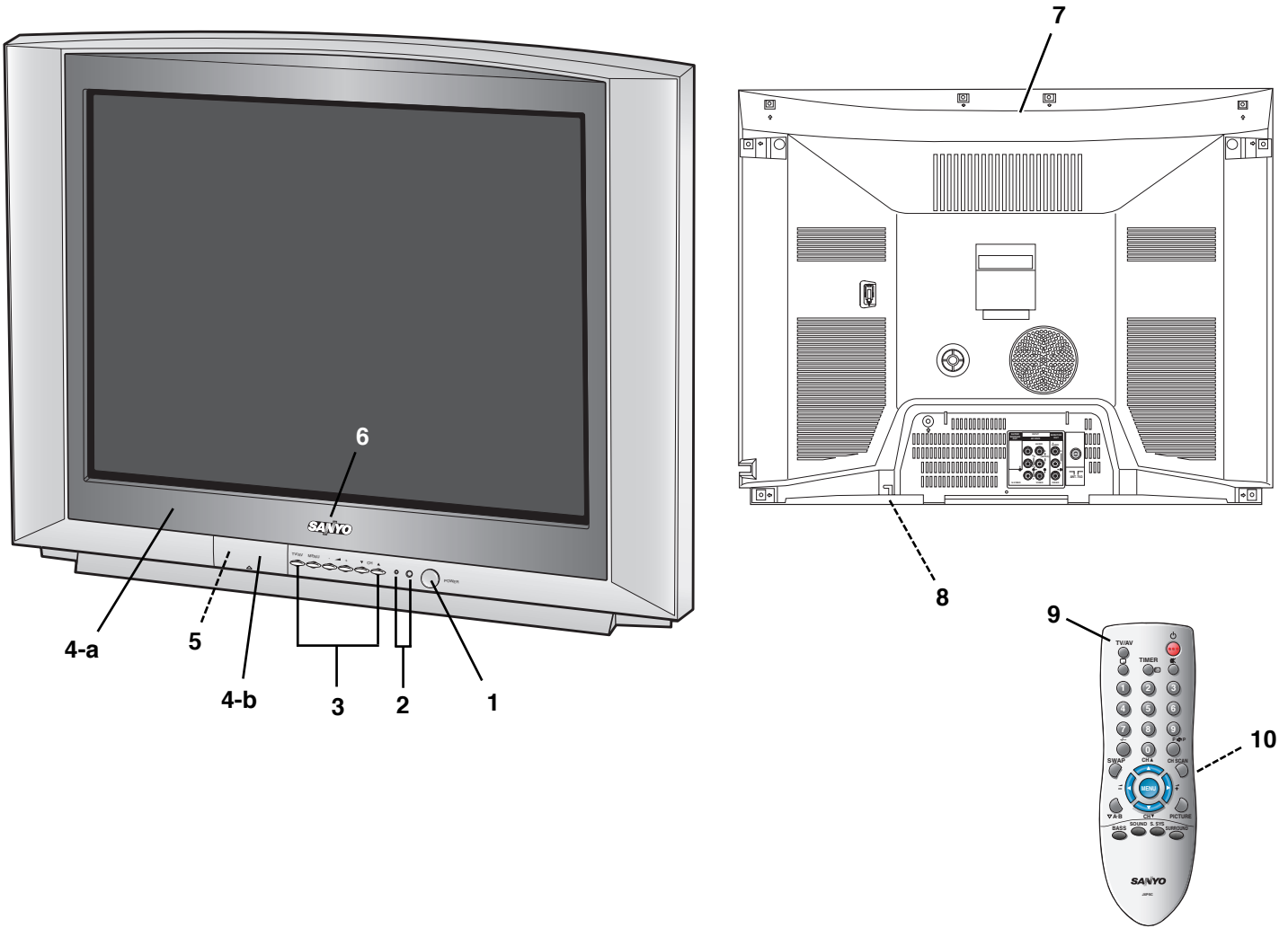

Key No.	Part No.	Description	Key No.	Part No.	Description
1	610 332 2247	BUTTON PW-BA5A			
	610 229 8406	SPRING-E3HA (for power button)			
2	610 314 4344	DEC.IND-C5ZJ			
3	610 330 3499	BUTTON UNITED-BA4A			
4	610 331 5256	ASSY,CABINET FR-BA4A			
4-a	610 330 3369	CABINET FRONT-BA4A			
4-b	610 316 1723	DOOR-C7LA			
5	610 284 7741	DOOR COVER-C2SA			
6	645 069 2185	BADGE,SANYO*43.5X10L43.5			
7	610 321 7802	CABINET BACK-C7GA			
8	610 256 7670	HOLDER AC CORD-SGP-D4VA			
9	645 071 1145	ASSY,REMOCON JXPSC			
or	652 002 0634	REMOCON,JXPSC			
10	610 313 3393	RC-BATTERY LID-JXPLA			
	610 333 6459	INSTRUCTION MANUAL-C7GH-B			

Chassis Electrical Parts List

BA4H

Product safety should be considered when a component replacement is made in any area of a receiver. Components indicated by a Δ mark in this parts list and the circuit diagram show components whose value have special significance to product safety. It is particularly recommended that only parts specified on the following parts list be used for components replacement pointed out by the mark.

Note: Parts order must contain Service Ref. No., Part No., and descriptions. The main PCB unit will be supplied without tuner and flyback transformer. They should be ordered separately.

Ref. No.	Part No.	Description	Ref. No.	Part No.	Description
<p>NOTES: Read description in the Capacitor and Resistor as follows:</p> <p>CAPACITOR CERAMIC 100P K 50V</p> <p style="margin-left: 150px;">Rated Voltage</p> <p style="margin-left: 150px;">Tolerance Symbols: Less than 10pF A : Not specified B : $\pm 0.1\text{pF}$ C : $\pm 0.25\text{pF}$ D : $\pm 0.5\text{pF}$ F : $\pm 1\text{PF}$ G : $\pm 2\text{pF}$ R : $\pm 0.25\text{-}0\text{pF}$ S : $\pm 0\text{-}0.25\text{pF}$ E : $\pm 0\text{-}1\text{pF}$ More than 10pF A : Not specified B : $\pm 0.1\%$ C : $\pm 0.25\%$ D : $\pm 0.5\%$ F : $\pm 1\%$ G : $\pm 2\%$ H : $\pm 3\%$ J : $\pm 5\%$ K : $\pm 10\%$ L : $\pm 15\%$ M : $\pm 20\%$ N : $\pm 30\%$ P : $\pm 100\text{-}0\%$ Q : $\pm 30\text{-}10\%$ T : $\pm 50\text{-}10\%$ U : $\pm 75\text{-}10\%$ V : $\pm 20\text{-}10\%$ W : $\pm 100\text{-}10\%$ X : $\pm 40\text{-}20\%$ Y : $\pm 150\text{-}10\%$ Z : $\pm 80\text{-}20\%$</p> <p style="margin-left: 150px;">Rated value: P=pico farad, U=micro farad</p> <p>Material: CERAMIC..... Ceramic MT-PAPER..... Metallized Paper POLYESTER..... Polyester MT-POLYEST.....Metallized Polyester POLYPRO..... Polypropylene MT-POLYPRO....Metallized Polypropylene COMPO FILM..... Composite film MT-COMPO..... Metallized Composite STYRENE..... Styrene TA-SOLID..... Tantalum Solid AL-SOLID..... Aluminium Solid ELECT..... Electrolytic NP-ELECT..... Non-polarised Electrolytic OS-SOLID..... Aluminium Solid with Organic Semiconductive Electrolytic DL-ELECT..... Double Layered Electrolytic</p> <p>RESISTOR CARBON 4.7K J A 1/4W</p> <p style="margin-left: 150px;">Rated Wattage</p> <p style="margin-left: 150px;">Performance Symbols: A: General B: Non flammable Z: Low noise Other: Temperature coefficient</p> <p style="margin-left: 150px;">Tolerance Symbols: A: $\pm 0.05\%$ B: $\pm 0.1\%$ C: $\pm 0.25\%$ D: $\pm 0.5\%$ F: $\pm 1\%$ G: $\pm 2\%$ J: $\pm 5\%$ K: $\pm 10\%$ M: $\pm 20\%$ P: $\pm 5\text{-}15\%$</p> <p style="margin-left: 150px;">Rated value, ohms: K: 1,000, M: 1,000,000</p> <p>Material: CARBON..... Carbon MT-FILM..... Metal Film OXIDE-MT..... Oxide Metal Film SOLID..... Composition MT-GLAZE..... Metal Glaze WIRE WOUND... Wire Wound CERAMIC RES.. Ceramic FUSIBLE RES.... Fusible</p>			<p>OUT OF CIRCUIT BOARD</p> <p>PICTURE TUBE Δ Q901 4140145805 CRT A68QFN893X001</p> <p>COIL Δ L901 6450854712 ASSY, COIL, DEGAUSSING</p> <p>MISCELLANEOUS SP901 6520001244 SPEAKER, 8 SP902 6520001244 SPEAKER, 8 Δ W901 6450399251 CORD, POWER-2.0MK-A5003 6450646096 CORD, POWER-2.0MK-A5003 W903 6103052182 ASSY, WIRE GND CONNECTOR C</p> <p>6103346304 ASSY, PWB, MAIN BA4H 1AA0B10S218KA</p> <p>TRANSISTOR Q003 4051648412 TR KTC3875S-GR-RTK 4050144519 TR 2SC2412K T146 R 4050144618 TR 2SC2412K T146 S 4050158724 TR 2SC2812-L6-TB 4050158922 TR 2SC2812-L7-TB 4051631612 TR 2SC2812N-L6-TB0 4051739813 TR 2SC3928A1R 4051739912 TR 2SC3928A1S Q004 4051648412 TR KTC3875S-GR-RTK 4050144519 TR 2SC2412K T146 R 4050144618 TR 2SC2412K T146 S 4050158724 TR 2SC2812-L6-TB 4050158922 TR 2SC2812-L7-TB 4051631612 TR 2SC2812N-L6-TB0 4051739813 TR 2SC3928A1R 4051739912 TR 2SC3928A1S Q008 4051648412 TR KTC3875S-GR-RTK 4050144519 TR 2SC2412K T146 R 4050144618 TR 2SC2412K T146 S 4050158724 TR 2SC2812-L6-TB 4050158922 TR 2SC2812-L7-TB 4051631612 TR 2SC2812N-L6-TB0 4051739813 TR 2SC3928A1R 4051739912 TR 2SC3928A1S Q010 4051648016 TR KTA1504S-GR-RTK 4051345925 TR 2SA1037AK-T146-R 4051472215 TR 2SA1037AK-S-T146 4050020318 TR 2SA1037K T146 R 4050020417 TR 2SA1037K T146 S 4050026726 TR 2SA1179-M6-TB 4050026924 TR 2SA1179-M7-TB 4051631513 TR 2SA1179N-M6-TB 4051739615 TR 2SA1235A1E 4051739714 TR 2SA1235A1F Q011 4051648412 TR KTC3875S-GR-RTK 4050144519 TR 2SC2412K T146 R</p>		

Ref. No.	Part No.	Description	Ref. No.	Part No.	Description
	4050144618	TR 2SC2412K T146 S		4050207719	TR 2SC945A-QA
	4050158724	TR 2SC2812-L6-TB		4050207917	TR 2SC945A-RA
	4050158922	TR 2SC2812-L7-TB	Q491	4051648016	TR KTA1504S-GR-RTK
	4051631612	TR 2SC2812N-L6-TB0		4051345925	TR 2SA1037AK-T146-R
	4051739813	TR 2SC3928A1R		4051472215	TR 2SA1037AK-S-T146
	4051739912	TR 2SC3928A1S		4050020318	TR 2SA1037K T146 R
Q1001	4051648016	TR KTA1504S-GR-RTK		4050020417	TR 2SA1037K T146 S
	4051345925	TR 2SA1037AK-T146-R		4050026726	TR 2SA1179-M6-TB
	4051472215	TR 2SA1037AK-S-T146		4050026924	TR 2SA1179-M7-TB
	4050020318	TR 2SA1037K T146 R		4051631513	TR 2SA1179N-M6-TB
	4050020417	TR 2SA1037K T146 S		4051739615	TR 2SA1235A1E
	4050026726	TR 2SA1179-M6-TB		4051739714	TR 2SA1235A1F
	4050026924	TR 2SA1179-M7-TB	Q511	4051648412	TR KTC3875S-GR-RTK
	4051631513	TR 2SA1179N-M6-TB		4050144519	TR 2SC2412K T146 R
	4051739615	TR 2SA1235A1E		4050144618	TR 2SC2412K T146 S
	4051739714	TR 2SA1235A1F		4050158724	TR 2SC2812-L6-TB
Q1002	4051648016	TR KTA1504S-GR-RTK		4050158922	TR 2SC2812-L7-TB
	4051345925	TR 2SA1037AK-T146-R		4051631612	TR 2SC2812N-L6-TB0
	4051472215	TR 2SA1037AK-S-T146		4051739813	TR 2SC3928A1R
	4050020318	TR 2SA1037K T146 R		4051739912	TR 2SC3928A1S
	4050020417	TR 2SA1037K T146 S	Q631	4051648412	TR KTC3875S-GR-RTK
	4050026726	TR 2SA1179-M6-TB		4050144519	TR 2SC2412K T146 R
	4050026924	TR 2SA1179-M7-TB		4050144618	TR 2SC2412K T146 S
	4051631513	TR 2SA1179N-M6-TB		4050158724	TR 2SC2812-L6-TB
	4051739615	TR 2SA1235A1E		4050158922	TR 2SC2812-L7-TB
	4051739714	TR 2SA1235A1F		4051631612	TR 2SC2812N-L6-TB0
Q1003	4051648016	TR KTA1504S-GR-RTK		4051739813	TR 2SC3928A1R
	4051345925	TR 2SA1037AK-T146-R		4051739912	TR 2SC3928A1S
	4051472215	TR 2SA1037AK-S-T146	Q632	4051648412	TR KTC3875S-GR-RTK
	4050020318	TR 2SA1037K T146 R		4050144519	TR 2SC2412K T146 R
	4050020417	TR 2SA1037K T146 S		4050144618	TR 2SC2412K T146 S
	4050026726	TR 2SA1179-M6-TB		4050158724	TR 2SC2812-L6-TB
	4050026924	TR 2SA1179-M7-TB		4050158922	TR 2SC2812-L7-TB
	4051631513	TR 2SA1179N-M6-TB		4051631612	TR 2SC2812N-L6-TB0
	4051739615	TR 2SA1235A1E		4051739813	TR 2SC3928A1R
	4051739714	TR 2SA1235A1F		4051739912	TR 2SC3928A1S
Q111	4050159721	TR 2SC2814-F4-TB	Q641	4051648412	TR KTC3875S-GR-RTK
Q122	4051648412	TR KTC3875S-GR-RTK		4050144519	TR 2SC2412K T146 R
	4050144519	TR 2SC2412K T146 R		4050144618	TR 2SC2412K T146 S
	4050144618	TR 2SC2412K T146 S		4050158724	TR 2SC2812-L6-TB
	4050158724	TR 2SC2812-L6-TB		4050158922	TR 2SC2812-L7-TB
	4050158922	TR 2SC2812-L7-TB		4051631612	TR 2SC2812N-L6-TB0
	4051631612	TR 2SC2812N-L6-TB0		4051739813	TR 2SC3928A1R
	4051739813	TR 2SC3928A1R		4051739912	TR 2SC3928A1S
	4051739912	TR 2SC3928A1S	Q661	4052144200	TR KTC2026-Y-U/P
Q1902	4051413515	TR KTA1266-Y-T		4050599903	TR 2SD1913-R-RA
	4050061816	TR 2SA933S-R		4050600005	TR 2SD1913-S-RA
Q431	4050180517	TR 2SC3332-R	Q681	4051413317	TR KTC3198-GR-T
	4050180616	TR 2SC3332-S		4050118411	TR 2SC1740S-Q
Q432	4060182102	TR TT2190LS-YB11		4050118510	TR 2SC1740S-R
Q439	4051648412	TR KTC3875S-GR-RTK		4050118619	TR 2SC1740S-S
	4050144519	TR 2SC2412K T146 R		4050122012	TR 2SC1815-GR
	4050144618	TR 2SC2412K T146 S		4050207511	TR 2SC945A-PA
	4050158724	TR 2SC2812-L6-TB		4050207719	TR 2SC945A-QA
	4050158922	TR 2SC2812-L7-TB		4050207917	TR 2SC945A-RA
	4050158922	TR 2SC2812-L7-TB	Q683	4050890010	TR 2SA1707-S
	4051631612	TR 2SC2812N-L6-TB0		4050890119	TR 2SA1707-T
	4051739813	TR 2SC3928A1R		4050096917	TR 2SB985-S
	4051739912	TR 2SC3928A1S		4050097013	TR 2SB985-T
Q461	4050647307	TR 2SB1274-Q-RA	Q684	4051413317	TR KTC3198-GR-T
	4050647406	TR 2SB1274-R-RA		4050118411	TR 2SC1740S-Q
Q462	4051413317	TR KTC3198-GR-T		4050118510	TR 2SC1740S-R
	4050118411	TR 2SC1740S-Q		4050118619	TR 2SC1740S-S
	4050118510	TR 2SC1740S-R		4050122012	TR 2SC1815-GR
	4050118619	TR 2SC1740S-S		4050122111	TR 2SC1815-O
	4050122012	TR 2SC1815-GR		4050207511	TR 2SC945A-PA
	4050122111	TR 2SC1815-O			
	4050207511	TR 2SC945A-PA			

Ref. No.	Part No.	Description	Ref. No.	Part No.	Description
Q886	4050207719	TR 2SC945A-QA	C1005	4040968504	ELECT 10U M 50V
	4050207917	TR 2SC945A-RA		4040848905	ELECT 10U M 50V
	4051648412	TR KTC3875S-GR-RTK		4031957748	ELECT 10U M 50V
	4050144519	TR 2SC2412K T146 R	C1006	4032006722	ELECT 220U M 16V
	4050144618	TR 2SC2412K T146 S		C1007	4040968504
	4050158724	TR 2SC2812-L6-TB	4040848905		ELECT 10U M 50V
	4050158922	TR 2SC2812-L7-TB	C1008	4031957748	ELECT 10U M 50V
	4051631612	TR 2SC2812N-L6-TB0		4040968504	ELECT 10U M 50V
	4051739813	TR 2SC3928A1R		4040848905	ELECT 10U M 50V
4051739912	TR 2SC3928A1S	C1009	4031957748	ELECT 10U M 50V	
			4040968405	ELECT 1U M 50V	
INTEGRATED CIRCUIT				4040848806	ELECT 1U M 50V
IC001	4096216109	IC TDA8944J/N1		4032001123	ELECT 1U M 50V
IC201	4106203402	IC LA76938NDE56S0-E	C101	4041072002	ELECT 470U M 16V
IC202	4092415407	IC BA178M05T		4040848301	ELECT 470U M 16V
	4094636701	IC KIA7805API	C1010	4031768621	ELECT 470U M 16V
	4092654806	IC L78M05CV		4041087501	ELECT 0.1U M 50V
IC3701	4095922734	IC LV1116NV-TLM-E		4040871606	ELECT 0.1U M 50V
IC501	4094535905	IC LA78041		4032002219	ELECT 0.1U M 50V
IC601	4105643100	IC STR-W6754(LF2003)	C1011	4033670417	CERAMIC 0.1U K 50V
IC651	4092415407	IC BA178M05T		C1012	4040968405
	4094636701	IC KIA7805API	4040848806		ELECT 1U M 50V
	4092654806	IC L78M05CV	C104	4032001123	ELECT 1U M 50V
IC801	4096760701	IC LE24C161-E-C		4040973508	ELECT 47U M 50V
	4104958007	IC AT24C16A-10PU-2.7		4040849308	ELECT 47U M 50V
	4094594506	IC 24LC16B/P	C106	4032001727	ELECT 47U M 50V
				4040973102	ELECT 22U M 50V
CAPACITOR				4040875406	ELECT 22U M 50V
C001	4040972303	ELECT 1K U M 25V	C108	4032001529	ELECT 22U M 50V
	4040848400	ELECT 1000U M 25V		4031133815	CERAMIC 1000P K 50V
	4031977340	ELECT 1000U M 25V		C111	4032152211
C004	4040971900	ELECT 220U M 16V	C112		4032152211
	4040848004	ELECT 220U M 16V		C114	4032152211
	4032006722	ELECT 220U M 16V	C120		4030755315
C006	4041086306	ELECT 33U M 16V		C121	4032152112
	4040897804	ELECT 33U M 16V	C122		4032152211
	4032006524	ELECT 33U M 16V		4040971702	ELECT 100U M 16V
C009	4040968504	ELECT 10U M 50V	C123	4040847809	ELECT 100U M 16V
	4040848905	ELECT 10U M 50V		4031957837	ELECT 100U M 16V
	4031957748	ELECT 10U M 50V	C132	4011506011	MT-GLAZE 0.000 ZA 1/10W
C012	4032989619	CERAMIC 0.1U K 16V		4011057919	MT-GLAZE 0.000 ZA 1/16W
	4033670417	CERAMIC 0.1U K 50V	C138	4033363517	CERAMIC 0.47U K 16V
C015	4011506011	MT-GLAZE 0.000 ZA 1/10W		C171	4032844314
	4011057919	MT-GLAZE 0.000 ZA 1/16W	C172		4031552111
C017	4030708816	CERAMIC 1500P K 50V		C174	4032152211
	4031552111	CERAMIC 1500P K 50V	C176		4031571914
C018	4030708816	CERAMIC 1500P K 50V		C1902	4011506011
	4031552111	CERAMIC 1500P K 50V	4011057919		MT-GLAZE 0.000 ZA 1/16W
C020	4041086306	ELECT 33U M 16V	C201	4040973102	ELECT 22U M 50V
	4040897804	ELECT 33U M 16V		4040875406	ELECT 22U M 50V
	4032006524	ELECT 33U M 16V	C202	4032001529	ELECT 22U M 50V
C022	4032989619	CERAMIC 0.1U K 16V		4032152211	CERAMIC 0.01U K 50V
	4033670417	CERAMIC 0.1U K 50V	C203	4031793217	POLYESTER 0.015U J 50V
C025	4032121613	CERAMIC 0.22U Z 25V		C204	4032152211
C026	4032121613	CERAMIC 0.22U Z 25V	4040968306		ELECT 100U M 25V
C1001	4040968405	ELECT 1U M 50V	C210	4040897200	ELECT 100U M 25V
	4040848806	ELECT 1U M 50V		4031957936	ELECT 100U M 25V
	4032001123	ELECT 1U M 50V	C212	4041088102	ELECT 100U M 50V
C1002	4040968504	ELECT 10U M 50V		4032001826	ELECT 100U M 50V
	4040848905	ELECT 10U M 50V	C215	4031554214	CERAMIC 15P J 50V
	4031957748	ELECT 10U M 50V		4040968405	ELECT 1U M 50V
C1003	4040968504	ELECT 10U M 50V	C224	4040848806	ELECT 1U M 50V
	4040848905	ELECT 10U M 50V		4032001123	ELECT 1U M 50V
	4031957748	ELECT 10U M 50V	C225	4032052818	CERAMIC 0.047U K 25V
C1004	4040968504	ELECT 10U M 50V		4040972709	ELECT 0.47U M 50V
	4040848905	ELECT 10U M 50V	4040848707	ELECT 0.47U M 50V	
	4031957748	ELECT 10U M 50V	4032002625	ELECT 0.47U M 50V	

Ref. No.	Part No.	Description	Ref. No.	Part No.	Description
C226	4040972709	ELECT 0.47U M 50V	C3719	4031577114	CERAMIC 2700P K 50V
	4040848707	ELECT 0.47U M 50V	C3720	4033077018	CERAMIC 0.068U K 16V
	4032002625	ELECT 0.47U M 50V		4033709117	CERAMIC 0.068U K 50V
C227	4032152211	CERAMIC 0.01U K 50V	C3721	4033077018	CERAMIC 0.068U K 16V
C231	4030677815	MT-COMPO 0.47U J 50V		4033709117	CERAMIC 0.068U K 50V
	4032560848	MT-COMPO 0.47U J 50V	C3722	4040968405	ELECT 1U M 50V
C232	4032152211	CERAMIC 0.01U K 50V		4040848806	ELECT 1U M 50V
C233	4041072101	ELECT 10U M 25V		4032001123	ELECT 1U M 50V
	4040871507	ELECT 10U M 25V	C3724	4040968405	ELECT 1U M 50V
C234	4032152211	CERAMIC 0.01U K 50V		4040848806	ELECT 1U M 50V
C243	4032152211	CERAMIC 0.01U K 50V		4032001123	ELECT 1U M 50V
C244	4041072507	ELECT 47U M 25V	C420	4040774402	MT-POLYPRO 7200P H 1.5K
	4040874904	ELECT 47U M 25V		4041008902	MT-POLYPRO 7200P H 1.5K
	4032005022	ELECT 47U M 25V		4033437911	MT-POLYPRO 7200P H 1.5K
C245	4040968405	ELECT 1U M 50V	C423	4040774204	MT-POLYPRO 7000P H 1.5K
	4040848806	ELECT 1U M 50V		4041009503	MT-POLYPRO 7000P H 1.5K
	4032001123	ELECT 1U M 50V		4033472516	MT-POLYPRO 7000P H 1.5K
C247	4040972907	ELECT 2.2U M 50V	C424	4033439410	POLYPRO 0.02U J 400V
	4040849001	ELECT 2.2U M 50V	C425	4040869405	POLYPRO 0.018U J 400V
	4032001222	ELECT 2.2U M 50V		4030833914	POLYPRO 0.018U J 400V
C273	4033423310	CERAMIC 0.1U K 25V	C432	4031149519	CERAMIC 1000P K 500V
C291	4040968207	ELECT 47U M 16V	C433	4032753329	CERAMIC 3900P K 500V
	4040848202	ELECT 47U M 16V	C434-TM	4040968801	ELECT 470U M 35V
	4032006623	ELECT 47U M 16V		4040849506	ELECT 470U M 35V
C355	4031032257	CERAMIC 100P K 50V		4032002130	ELECT 470U M 35V
C358	4040968405	ELECT 1U M 50V	C437	4031589206	MT-POLYEST 2.2U K 250V
	4040848806	ELECT 1U M 50V	C439	4033145915	CERAMIC 0.47U K 16V
	4032001123	ELECT 1U M 50V	C441	4030790910	MT-POLYPRO 0.15U J 400V
C3701	4040968405	ELECT 1U M 50V	C442	4032673211	MT-POLYPRO 0.18U J 400V
	4040848806	ELECT 1U M 50V	C463	4030617534	POLYESTER 4700P J 50V
	4032001123	ELECT 1U M 50V		4031791213	POLYESTER 4700P J 50V
C3702	4040973300	ELECT 4.7U M 50V	C465	4030660104	MT-POLYEST 2.2U K 100V
	4040849209	ELECT 4.7U M 50V		4031589107	MT-POLYEST 2.2U K 100V
	4032001420	ELECT 4.7U M 50V	C467	4032602043	MT-COMPO 1U J 50V
C3703	4031552418	CERAMIC 5600P K 50V	C468	4040973102	ELECT 22U M 50V
C3704	4032152211	CERAMIC 0.01U K 50V		4040875406	ELECT 22U M 50V
C3705	4031577114	CERAMIC 2700P K 50V		4032001529	ELECT 22U M 50V
C3706	4033077018	CERAMIC 0.068U K 16V	C469	4040968504	ELECT 10U M 50V
	4033709117	CERAMIC 0.068U K 50V		4040848905	ELECT 10U M 50V
C3707	4033077018	CERAMIC 0.068U K 16V		4031957748	ELECT 10U M 50V
	4033709117	CERAMIC 0.068U K 50V	C470	4032462221	MT-COMPO 0.01U J 50V
C3708	4040968405	ELECT 1U M 50V	C471	4040565208	NP-ELECT 2.2U M 100V
	4040848806	ELECT 1U M 50V		4040847007	NP-ELECT 2.2U M 100V
	4032001143	ELECT 1U M 50V	C482	4041106905	ELECT 0.47U M 160V
C3710	4040968405	ELECT 1U M 50V	C486	4040981602	ELECT 33U M 250V
	4040848806	ELECT 1U M 50V	C491	4034164915	CERAMIC 680P K 500V
	4032001123	ELECT 1U M 50V	C510	4040973102	ELECT 22U M 50V
C3711	4040973300	ELECT 4.7U M 50V		4040875406	ELECT 22U M 50V
	4040849209	ELECT 4.7U M 50V		4032001529	ELECT 22U M 50V
	4032001420	ELECT 4.7U M 50V	C511	4040968504	ELECT 10U M 50V
C3712	4040968009	ELECT 1000U M 16V		4040848905	ELECT 10U M 50V
	4040847908	ELECT 1000U M 16V		4031957748	ELECT 10U M 50V
	4032006930	ELECT 1000U M 16V	C514	4041072705	ELECT 3.3U M 50V
C3713	4040973300	ELECT 4.7U M 50V		4040849100	ELECT 3.3U M 50V
	4040849209	ELECT 4.7U M 50V		4032001321	ELECT 3.3U M 50V
	4032001420	ELECT 4.7U M 50V	C515	4041087006	ELECT 2200U M 25V
C3714	4040968405	ELECT 1U M 50V		4040886600	ELECT 2200U M 25V
	4040848806	ELECT 1U M 50V		4031943840	ELECT 2200U M 25V
	4032001123	ELECT 1U M 50V	C517	4040968603	ELECT 220U M 35V
C3715	4040973300	ELECT 4.7U M 50V		4040849407	ELECT 220U M 35V
	4040849209	ELECT 4.7U M 50V		4032003523	ELECT 220U M 35V
	4032001420	ELECT 4.7U M 50V	C518	4031041922	CERAMIC 3300P K 50V
C3716	4040973300	ELECT 4.7U M 50V	C520	4030641212	POLYESTER 0.1U K 100V
	4040849209	ELECT 4.7U M 50V		4032769726	POLYESTER 0.1U K 100V
	4032001420	ELECT 4.7U M 50V	C521	4040980506	ELECT 1000U M 35V
C3717	4031577312	CERAMIC 6800P K 50V		4040886709	ELECT 1000U M 35V
C3718	4033423310	CERAMIC 0.1U K 25V		4032000146	ELECT 1000U M 35V

Ref. No.	Part No.	Description	Ref. No.	Part No.	Description
C524	4030641212	POLYESTER 0.1U K 100V		4040559801	ELECT 220U M 200V
	4032769726	POLYESTER 0.1U K 100V		4040973706	ELECT 220U M 160V
C525TM	4031042820	CERAMIC 56P J 50V	C643	4040968801	ELECT 470U M 35V
△C601	4040881704	MT-POLYEST 0.22U K 250V		4040849506	ELECT 470U M 35V
	4040662204	MT-POLYEST 0.22U M 275V		4032002130	ELECT 470U M 35V
	4040888802	MT-POLYEST 0.22U M 275V	C644	4040972303	ELECT 1K U M 25V
	4040941804	MT-POLYEST 0.22U K 275V		4040848400	ELECT 1000U M 25V
△C602	4040796503	MT-POLYEST 0.068U M 250V		4031977340	ELECT 1000U M 25V
	4040737506	MT-POLYEST 0.068U M 275V	C645	4041087006	ELECT 2200U M 25V
	4040920700	MT-POLYEST 0.068U M 275V		4040886600	ELECT 2200U M 25V
C607	4040846307	CERAMIC 1000P K 1K		4031943840	ELECT 2200U M 25V
	4030766707	CERAMIC 1000P K 1K	C649	4040973102	ELECT 22U M 50V
	4033128225	CERAMIC 1000P K 1K		4040875406	ELECT 22U M 50V
C608	4040846307	CERAMIC 1000P K 1K		4032001529	ELECT 22U M 50V
	4030766707	CERAMIC 1000P K 1K	C650	4040973300	ELECT 4.7U M 50V
	4033128225	CERAMIC 1000P K 1K		4040849209	ELECT 4.7U M 50V
C609A	4040787600	ELECT 270U M 400V		4032001420	ELECT 4.7U M 50V
C610	4032769112	POLYESTER 470P J 50V	C651	4041071906	ELECT 470U M 10V
C611	4040968405	ELECT 1U M 50V		4040847601	ELECT 470U M 10V
	4040848806	ELECT 1U M 50V		4032008221	ELECT 470U M 10V
	4032001123	ELECT 1U M 50V	C661	4040968504	ELECT 10U M 50V
C612	4031791718	POLYESTER 0.033U J 50V		4040848905	ELECT 10U M 50V
C613	4031792715	POLYESTER 2200P J 50V		4031957748	ELECT 10U M 50V
C614	4010694511	OXIDE-MT 68K JA 2W	C662	4040971900	ELECT 220U M 16V
C615	4041087907	ELECT 22U M 35V		4040848004	ELECT 220U M 16V
	4040875802	ELECT 22U M 35V		4032006722	ELECT 220U M 16V
	4032003226	ELECT 22U M 35V	C663	4040972303	ELECT 1K U M 25V
C616	4041117703	CERAMIC 1000P K 2K		4040848400	ELECT 1000U M 25V
	4032468708	CERAMIC 1000P K 2K		4031977340	ELECT 1000U M 25V
	4034132914	CERAMIC 1000P K 2K	C691	4040968405	ELECT 1U M 50V
C617	4032188804	CERAMIC 220P K 2K		4040848806	ELECT 1U M 50V
	4034140117	CERAMIC 220P K 2K		4032001123	ELECT 1U M 50V
C626	4040735106	CERAMIC 470P K 250V	C801	4031397316	CERAMIC 18P J 50V
	4040714507	CERAMIC 470P K 400V	C802	4031397316	CERAMIC 18P J 50V
	4040978909	CERAMIC 470P K 400V	C803	4032152211	CERAMIC 0.01U K 50V
	4041039005	CERAMIC 470P K 400V	C805	4040971702	ELECT 100U M 16V
△C627	4040735106	CERAMIC 470P K 250V		4040847809	ELECT 100U M 16V
	4040714507	CERAMIC 470P K 400V		4031957837	ELECT 100U M 16V
	4040978909	CERAMIC 470P K 400V	C842	4033423310	CERAMIC 0.1U K 25V
	4041039005	CERAMIC 470P K 400V	C843	4033423310	CERAMIC 0.1U K 25V
△C628	4040733904	CERAMIC 1000P K 250V	C850	4040968504	ELECT 10U M 50V
	4040732105	CERAMIC 1000P M 250V		4040848905	ELECT 10U M 50V
	4040713302	CERAMIC 1000P M 400V		4031957748	ELECT 10U M 50V
	4040978503	CERAMIC 1000P K 400V	C863	4040968405	ELECT 1U M 50V
	4041039104	CERAMIC 1000P M 400V		4040848806	ELECT 1U M 50V
△C629	4040733904	CERAMIC 1000P K 250V		4032001123	ELECT 1U M 50V
	4040732105	CERAMIC 1000P M 250V	C893	4040972907	ELECT 2.2U M 50V
	4040713302	CERAMIC 1000P M 400V		4040849001	ELECT 2.2U M 50V
	4040978503	CERAMIC 1000P K 400V		4032001222	ELECT 2.2U M 50V
	4041039104	CERAMIC 1000P M 400V	C894	4032815017	CERAMIC 0.033U K 25V
C631	4041117703	CERAMIC 1000P K 2K			
	4032468708	CERAMIC 1000P K 2K	RESISTOR		
	4034132914	CERAMIC 1000P K 2K	R006	4012566311	MT-GLAZE 47K JA 1/10W
C632	4032475023	CERAMIC 470P K 1K		4011055410	MT-GLAZE 47K JA 1/16W
	4034084520	CERAMIC @470P K 1K	R008	4011505816	MT-GLAZE 100K JA 1/10W
	4034084510	CERAMIC 470P K 1K		4011050712	MT-GLAZE 100K JA 1/16W
C633	4032475023	CERAMIC 470P K 1K	R009	4010275938	CARBON 68K JA 1/6W
	4034084520	CERAMIC @470P K 1K	R010	4011623817	MT-GLAZE 470K JA 1/10W
	4034084510	CERAMIC 470P K 1K		4011055519	MT-GLAZE 470K JA 1/16W
C634	4032475023	CERAMIC 470P K 1K	R011	4012561712	MT-GLAZE 33K JA 1/10W
	4034084520	CERAMIC @470P K 1K		4011054215	MT-GLAZE 33K JA 1/16W
	4034084510	CERAMIC 470P K 1K	R012	4012567219	MT-GLAZE 18K JA 1/10W
C636	4040968504	ELECT 10U M 50V		4011052112	MT-GLAZE 18K JA 1/16W
	4040848905	ELECT 10U M 50V	R017	4011506110	MT-GLAZE 2.2K JA 1/10W
	4031957748	ELECT 10U M 50V		4011052815	MT-GLAZE 2.2K JA 1/16W
C637	4033670417	CERAMIC 0.1U K 50V	R021	4012561712	MT-GLAZE 33K JA 1/10W
C641	4040739005	ELECT 220U M 160V		4011054215	MT-GLAZE 33K JA 1/16W

Ref. No.	Part No.	Description	Ref. No.	Part No.	Description
R022	4012567219	MT-GLAZE 18K JA 1/10W		4011050415	MT-GLAZE 100 JA 1/16W
	4011052112	MT-GLAZE 18K JA 1/16W	R108	4012567219	MT-GLAZE 18K JA 1/10W
R031	4012566311	MT-GLAZE 47K JA 1/10W		4011052112	MT-GLAZE 18K JA 1/16W
	4011055410	MT-GLAZE 47K JA 1/16W	R109	4012566618	MT-GLAZE 68K JA 1/10W
R037	4011506110	MT-GLAZE 2.2K JA 1/10W		4011058213	MT-GLAZE 68K JA 1/16W
	4011052815	MT-GLAZE 2.2K JA 1/16W	R1106	4010099346	CARBON 390 JA 1/2W
R038	4011506219	MT-GLAZE 1K JA 1/10W	R1107	4010099346	CARBON 390 JA 1/2W
	4011050514	MT-GLAZE 1K JA 1/16W	R111	4011506219	MT-GLAZE 1K JA 1/10W
R1001	4012562719	MT-GLAZE 75 JA 1/10W		4011050514	MT-GLAZE 1K JA 1/16W
	4011134412	MT-GLAZE 75 JA 1/16W	R112	4011624111	MT-GLAZE 5.6K JA 1/10W
R1002	4011506219	MT-GLAZE 1K JA 1/10W		4011056011	MT-GLAZE 5.6K JA 1/16W
	4011050514	MT-GLAZE 1K JA 1/16W	R114	4011523216	MT-GLAZE 330 JA 1/10W
R1003	4012567219	MT-GLAZE 18K JA 1/10W		4011054017	MT-GLAZE 330 JA 1/16W
	4011052112	MT-GLAZE 18K JA 1/16W	R115	4010272135	CARBON 56 JA 1/6W
R1004	4011506219	MT-GLAZE 1K JA 1/10W	R116	4012564119	MT-GLAZE 56 JA 1/10W
	4011050514	MT-GLAZE 1K JA 1/16W		4011055816	MT-GLAZE 56 JA 1/16W
R1005	4012567219	MT-GLAZE 18K JA 1/10W	R121	4012567318	MT-GLAZE 6.8K JA 1/10W
	4011052112	MT-GLAZE 18K JA 1/16W		4011056615	MT-GLAZE 6.8K JA 1/16W
R1006	4011506110	MT-GLAZE 2.2K JA 1/10W	R122	4011506110	MT-GLAZE 2.2K JA 1/10W
	4011052815	MT-GLAZE 2.2K JA 1/16W		4011052815	MT-GLAZE 2.2K JA 1/16W
R1007	4011505816	MT-GLAZE 100K JA 1/10W	R124	4011505915	MT-GLAZE 10K JA 1/10W
	4011050712	MT-GLAZE 100K JA 1/16W		4011050613	MT-GLAZE 10K JA 1/16W
R1008	4011506110	MT-GLAZE 2.2K JA 1/10W	R125	4012566014	MT-GLAZE 27K JA 1/10W
	4011052815	MT-GLAZE 2.2K JA 1/16W		4011053416	MT-GLAZE 27K JA 1/16W
R1009	4011505816	MT-GLAZE 100K JA 1/10W	R130	4011506011	MT-GLAZE 0.000 ZA 1/10W
	4011050712	MT-GLAZE 100K JA 1/16W		4011057919	MT-GLAZE 0.000 ZA 1/16W
R101	4011506011	MT-GLAZE 0.000 ZA 1/10W	R132	4011623619	MT-GLAZE 470 JA 1/10W
	4011057919	MT-GLAZE 0.000 ZA 1/16W		4011055212	MT-GLAZE 470 JA 1/16W
R1010	4012562719	MT-GLAZE 75 JA 1/10W	R140	4011624012	MT-GLAZE 560 JA 1/10W
	4011134412	MT-GLAZE 75 JA 1/16W		4011055915	MT-GLAZE 560 JA 1/16W
R1011	4011505816	MT-GLAZE 100K JA 1/10W	R141	4011624012	MT-GLAZE 560 JA 1/10W
	4011050712	MT-GLAZE 100K JA 1/16W		4011055915	MT-GLAZE 560 JA 1/16W
R1012	4011506219	MT-GLAZE 1K JA 1/10W	R176	4011505915	MT-GLAZE 10K JA 1/10W
	4011050514	MT-GLAZE 1K JA 1/16W		4011050613	MT-GLAZE 10K JA 1/16W
R1013	4012567219	MT-GLAZE 18K JA 1/10W	R1902	4012560418	MT-GLAZE 12K JA 1/10W
	4011052112	MT-GLAZE 18K JA 1/16W		4011051115	MT-GLAZE 12K JA 1/16W
R1014	4011506219	MT-GLAZE 1K JA 1/10W	R1903	4011624111	MT-GLAZE 5.6K JA 1/10W
	4011050514	MT-GLAZE 1K JA 1/16W		4011056011	MT-GLAZE 5.6K JA 1/16W
R1015	4012567219	MT-GLAZE 18K JA 1/10W	R1904	4012567615	MT-GLAZE 3.9K JA 1/10W
	4011052112	MT-GLAZE 18K JA 1/16W		4011054611	MT-GLAZE 3.9K JA 1/16W
R1016	4012562719	MT-GLAZE 75 JA 1/10W	R1905	4011506110	MT-GLAZE 2.2K JA 1/10W
	4011134412	MT-GLAZE 75 JA 1/16W		4011052815	MT-GLAZE 2.2K JA 1/16W
R1017	4011506011	MT-GLAZE 0.000 ZA 1/10W	R1906	4011622810	MT-GLAZE 1.8K JA 1/10W
	4011057919	MT-GLAZE 0.000 ZA 1/16W		4011052013	MT-GLAZE 1.8K JA 1/16W
R1018	4012562719	MT-GLAZE 75 JA 1/10W	R1907	4010246730	CARBON 100 JA 1/6W
	4011134412	MT-GLAZE 75 JA 1/16W	R1911	4010257439	CARBON 220 JA 1/6W
R1019	4011506011	MT-GLAZE 0.000 ZA 1/10W	R1912	4010257439	CARBON 220 JA 1/6W
	4011057919	MT-GLAZE 0.000 ZA 1/16W	R1913	4010257439	CARBON 220 JA 1/6W
R1020	4012562719	MT-GLAZE 75 JA 1/10W	R210	4012556411	MT-GLAZE 3K JA 1/10W
	4011134412	MT-GLAZE 75 JA 1/16W		4011053713	MT-GLAZE 3K JA 1/16W
R1021	4012562719	MT-GLAZE 75 JA 1/10W	R211	4010246730	CARBON 100 JA 1/6W
	4011134412	MT-GLAZE 75 JA 1/16W	R212	4010251338	CARBON 150 JA 1/6W
R1026	4011506219	MT-GLAZE 1K JA 1/10W	R215	4011506011	MT-GLAZE 0.000 ZA 1/10W
	4011050514	MT-GLAZE 1K JA 1/16W		4011057919	MT-GLAZE 0.000 ZA 1/16W
R1027	4010247034	CARBON 1K JA 1/6W	R225	4012560418	MT-GLAZE 12K JA 1/10W
R1028	4011506219	MT-GLAZE 1K JA 1/10W		4011051115	MT-GLAZE 12K JA 1/16W
	4011050514	MT-GLAZE 1K JA 1/16W	R226	4012566014	MT-GLAZE 27K JA 1/10W
R1029	4011506219	MT-GLAZE 1K JA 1/10W		4011053416	MT-GLAZE 27K JA 1/16W
	4011050514	MT-GLAZE 1K JA 1/16W	R227	4012561712	MT-GLAZE 33K JA 1/10W
R103	4010618111	OXIDE-MT 39K JA 1W		4011054215	MT-GLAZE 33K JA 1/16W
R1030	4011624012	MT-GLAZE 560 JA 1/10W	R228	4010254933	CARBON 180K JA 1/6W
	4011055915	MT-GLAZE 560 JA 1/16W	R229	4012567110	MT-GLAZE 680K JA 1/10W
R1031	4011506219	MT-GLAZE 1K JA 1/10W		4011056714	MT-GLAZE 680K JA 1/16W
	4011050514	MT-GLAZE 1K JA 1/16W	R230	4010269333	CARBON 47 JA 1/6W
R106	4012556510	MT-GLAZE 100 JA 1/10W	R231	4011506110	MT-GLAZE 2.2K JA 1/10W
	4011050415	MT-GLAZE 100 JA 1/16W		4011052815	MT-GLAZE 2.2K JA 1/16W
R107	4012556510	MT-GLAZE 100 JA 1/10W	R232	4011506110	MT-GLAZE 2.2K JA 1/10W

Ref. No.	Part No.	Description	Ref. No.	Part No.	Description
	4011052815	MT-GLAZE 2.2K JA 1/16W	R493	4011623619	MT-GLAZE 470 JA 1/10W
R233	4011506110	MT-GLAZE 2.2K JA 1/10W		4011055212	MT-GLAZE 470 JA 1/16W
	4011052815	MT-GLAZE 2.2K JA 1/16W	R494	4011623619	MT-GLAZE 470 JA 1/10W
R234	4012560012	MT-GLAZE 120 JA 1/10W		4011055212	MT-GLAZE 470 JA 1/16W
	4011050910	MT-GLAZE 120 JA 1/16W	R501A	4010648603	OXIDE-MT 1K JA 2W
R235	4012560012	MT-GLAZE 120 JA 1/10W	R502	4010272630	CARBON 5.6K JA 1/6W
	4011050910	MT-GLAZE 120 JA 1/16W	R510	4010247440	CARBON 10K JA 1/6W
R236	4012560012	MT-GLAZE 120 JA 1/10W	R511	4010247440	CARBON 10K JA 1/6W
	4011050910	MT-GLAZE 120 JA 1/16W	R514	4010247440	CARBON 10K JA 1/6W
R243	4010683703	OXIDE-MT 470 JA 2W	R515	4010267438	CARBON 39K JA 1/6W
R244	4012566311	MT-GLAZE 47K JA 1/10W	R516	4010251932	CARBON 15K JA 1/6W
	4011055410	MT-GLAZE 47K JA 1/16W	R517	4010652818	OXIDE-MT 120 JA 2W
R245	4012566311	MT-GLAZE 47K JA 1/10W	R518	4010579115	OXIDE-MT 1.2 JA 1W
	4011055410	MT-GLAZE 47K JA 1/16W	R519	4010246730	CARBON 100 JA 1/6W
R280	4010246730	CARBON 100 JA 1/6W	R522	4010257439	CARBON 220 JA 1/6W
R286	4012651710	MT-GLAZE 4.7K FA 1/10W	R602	4020998200	WIRE WOUND 1.8 KA 10W
	4012039914	MT-GLAZE 4.7K FA 1/16W	R603	4010643816	OXIDE-MT 1 JA 2W
R290	4010686219	OXIDE-MT 5.6 JA 2W	R604	4011808412	OXIDE-MT 0.47 JA 2W
R340	4012559719	MT-GLAZE 82K JA 1/10W	R606	4030840318	POLYPRO 0.022U J 630V
	4011057513	MT-GLAZE 82K JA 1/16W	R607	4010246433	CARBON 10 JA 1/6W
R351	4010256531	CARBON 20K JA 1/6W	R608	4010585918	OXIDE-MT 100K JA 1W
R352	4010127059	CARBON 10K JA 1/4W	R609	4010246730	CARBON 100 JA 1/6W
R355	4010127059	CARBON 10K JA 1/4W	R610	4010247034	CARBON 1K JA 1/6W
R357	4010267032	CARBON 3.9K JA 1/6W	R611	4010251635	CARBON 1.5K JA 1/6W
R358	4011506011	MT-GLAZE 0.000 ZA 1/10W	△R628	4020008602	SOLID 5.6M KA 1/2W
	4011057919	MT-GLAZE 0.000 ZA 1/16W		4020976604	CARBON 5.6M KA 1/2W
R3701	4012567615	MT-GLAZE 3.9K JA 1/10W	△R629	4020008602	SOLID 5.6M KA 1/2W
	4011054611	MT-GLAZE 3.9K JA 1/16W		4020976604	CARBON 5.6M KA 1/2W
R3702	4012567615	MT-GLAZE 3.9K JA 1/10W	R635	4010075815	CARBON 120K JA 1/2W
	4011054611	MT-GLAZE 3.9K JA 1/16W	R636	4010272630	CARBON 5.6K JA 1/6W
R3704	4010257439	CARBON 220 JA 1/6W	R637	4011505915	MT-GLAZE 10K JA 1/10W
R3705	4010257439	CARBON 220 JA 1/6W		4011050613	MT-GLAZE 10K JA 1/16W
R421	4010533226	MT-FILM 4.7K FA 1/6W	R638	4011623718	MT-GLAZE 4.7K JA 1/10W
R422	4010214036	CARBON 56K JA 1/4W		4011055311	MT-GLAZE 4.7K JA 1/16W
	4010214155	CARBON 56K JA 1/4W	R639	4011506219	MT-GLAZE 1K JA 1/10W
R423	4010172752	CARBON 27K JA 1/4W		4011050514	MT-GLAZE 1K JA 1/16W
	4010172841	CARBON 27K JA 1/4W	R640	4011505915	MT-GLAZE 10K JA 1/10W
R424	4010247034	CARBON 1K JA 1/6W		4011050613	MT-GLAZE 10K JA 1/16W
R426	4011505915	MT-GLAZE 10K JA 1/10W	R641	4012567318	MT-GLAZE 6.8K JA 1/10W
	4011050613	MT-GLAZE 10K JA 1/16W		4011056615	MT-GLAZE 6.8K JA 1/16W
R431	4010247034	CARBON 1K JA 1/6W	R642	4010247737	CARBON 100K JA 1/6W
R432	4011623619	MT-GLAZE 470 JA 1/10W	R643	4020974501	FUSIBLE RES 1 J- 1W
	4011055212	MT-GLAZE 470 JA 1/16W	R645	4010145132	CARBON 15K JA 1/4W
R433	4010071134	CARBON 1K JA 1/2W	R661	4010602714	OXIDE-MT 220 JA 1W
R434	4010602714	OXIDE-MT 220 JA 1W	R668	4010673110	OXIDE-MT 3.9 JA 2W
R435	4020803702	OXIDE-MT 6.8 JB 7W	R681	4011506219	MT-GLAZE 1K JA 1/10W
R437	4010247034	CARBON 1K JA 1/6W		4011050514	MT-GLAZE 1K JA 1/16W
R438	4010182850	CARBON 330 JA 1/4W	R685	4010146159	CARBON 150K JA 1/4W
R441	4010648712	OXIDE-MT 1K JA 2W	R686	4010127059	CARBON 10K JA 1/4W
R442	4010661414	OXIDE-MT 1.8K JA 2W	R687	4010191951	CARBON 3.9K JA 1/4W
R462	4010261337	CARBON 27K JA 1/6W	R688	4010258238	CARBON 22K JA 1/6W
R470	4010507524	MT-FILM 68K FA 1/4W	R689	4010273231	CARBON 560K JA 1/6W
R471	4010251635	CARBON 1.5K JA 1/6W	R690	4010251635	CARBON 1.5K JA 1/6W
R473	4010275235	CARBON 680 JA 1/6W	R801	4012565819	MT-GLAZE 270K JA 1/10W
R474	4010071134	CARBON 1K JA 1/2W		4011053515	MT-GLAZE 270K JA 1/16W
R475	4010095843	CARBON 330 JA 1/2W	R813	4011505915	MT-GLAZE 10K JA 1/10W
R479	4010257835	CARBON 2.2K JA 1/6W		4011050613	MT-GLAZE 10K JA 1/16W
R481	4010681610	OXIDE-MT 4.7 JA 2W	R814	4011505915	MT-GLAZE 10K JA 1/10W
R482	4010082615	CARBON 180K JA 1/2W		4011050613	MT-GLAZE 10K JA 1/16W
R483	4012559115	MT-GLAZE 2.2M JA 1/10W	R815	4011505915	MT-GLAZE 10K JA 1/10W
	4011140512	MT-GLAZE 2.2M JA 1/16W		4011050613	MT-GLAZE 10K JA 1/16W
R484	4010233750	CARBON 82K JA 1/4W	R817	4010247034	CARBON 1K JA 1/6W
R485	4010233750	CARBON 82K JA 1/4W	R818	4010247034	CARBON 1K JA 1/6W
R488	4020222008	FUSIBLE RES 1.0 J- 1/2W	R819	4011505915	MT-GLAZE 10K JA 1/10W
R491	4012560418	MT-GLAZE 12K JA 1/10W		4011050613	MT-GLAZE 10K JA 1/16W
	4011051115	MT-GLAZE 12K JA 1/16W	R830	4010247034	CARBON 1K JA 1/6W
R492	4010249731	CARBON 12K JA 1/6W	R834	4011505915	MT-GLAZE 10K JA 1/10W

Ref. No.	Part No.	Description	Ref. No.	Part No.	Description
	4011050613	MT-GLAZE 10K JA 1/16W		4071490817	DIODE 1SS355-TE-17
R837	4012563617	MT-GLAZE 15K JA 1/10W	D1001	4070639623	ZENER DIODE MTZJ9.1A
	4011051610	MT-GLAZE 15K JA 1/16W		4080480004	ZENER DIODE MTZJ9.1B
R838	4012563617	MT-GLAZE 15K JA 1/10W		4080480301	ZENER DIODE MTZJ9.1C-52
	4011051610	MT-GLAZE 15K JA 1/16W	D1002	4070639623	ZENER DIODE MTZJ9.1A
R839	4012556510	MT-GLAZE 100 JA 1/10W		4080480004	ZENER DIODE MTZJ9.1B
	4011050415	MT-GLAZE 100 JA 1/16W		4080480301	ZENER DIODE MTZJ9.1C-52
R840	4011623619	MT-GLAZE 470 JA 1/10W	D1003	4070639623	ZENER DIODE MTZJ9.1A
	4011055212	MT-GLAZE 470 JA 1/16W		4080480004	ZENER DIODE MTZJ9.1B
R841	4011623718	MT-GLAZE 4.7K JA 1/10W		4080480301	ZENER DIODE MTZJ9.1C-52
	4011055311	MT-GLAZE 4.7K JA 1/16W	D1004	4070638329	ZENER DIODE MTZJ11C
R842	4011623718	MT-GLAZE 4.7K JA 1/10W		4070541827	ZENER DIODE RD11EB3
	4011055311	MT-GLAZE 4.7K JA 1/16W	D1005	4070638329	ZENER DIODE MTZJ11C
R844	4012556510	MT-GLAZE 100 JA 1/10W		4070541827	ZENER DIODE RD11EB3
	4011050415	MT-GLAZE 100 JA 1/16W	D1006	4070638329	ZENER DIODE MTZJ11C
R845	4011505915	MT-GLAZE 10K JA 1/10W		4070541827	ZENER DIODE RD11EB3
	4011050613	MT-GLAZE 10K JA 1/16W	D1007	4070638329	ZENER DIODE MTZJ11C
R850	4012556510	MT-GLAZE 100 JA 1/10W		4070541827	ZENER DIODE RD11EB3
	4011050415	MT-GLAZE 100 JA 1/16W	D1008	4070638329	ZENER DIODE MTZJ11C
R852	4011505915	MT-GLAZE 10K JA 1/10W		4070541827	ZENER DIODE RD11EB3
	4011050613	MT-GLAZE 10K JA 1/16W	D1009	4070638329	ZENER DIODE MTZJ11C
R853	4011505915	MT-GLAZE 10K JA 1/10W		4070541827	ZENER DIODE RD11EB3
	4011050613	MT-GLAZE 10K JA 1/16W	D1010	4070638329	ZENER DIODE MTZJ11C
R863	4012566311	MT-GLAZE 47K JA 1/10W		4070541827	ZENER DIODE RD11EB3
	4011055410	MT-GLAZE 47K JA 1/16W	D1011	4070638329	ZENER DIODE MTZJ11C
R886	4011623015	MT-GLAZE 22K JA 1/10W		4070541827	ZENER DIODE RD11EB3
	4011052914	MT-GLAZE 22K JA 1/16W	D1012	4070638329	ZENER DIODE MTZJ11C
R887	4011623015	MT-GLAZE 22K JA 1/10W		4070541827	ZENER DIODE RD11EB3
	4011052914	MT-GLAZE 22K JA 1/16W	D102	4070995620	ZENER DIODE MTZJ6.8A
R888	4010272333	CARBON 560 JA 1/6W		4070574013	ZENER DIODE RD6.8EB1
R893	4012556015	MT-GLAZE 1M JA 1/10W		4080478506	ZENER DIODE MTZJ6.8A
	4011058015	MT-GLAZE 1M JA 1/16W	D103	4071000224	ZENER DIODE MTZJ36A
R894	4012556510	MT-GLAZE 100 JA 1/10W		4070562317	ZENER DIODE RD36EB1
	4011050415	MT-GLAZE 100 JA 1/16W		4080476106	ZENER DIODE MTZJ36A
			D122	4071661118	DIODE 1SS356-TW11
VARIABLE RESISTOR			D1901	4071589204	LED SPR-39MVWF
VR631	6450065514	VR, SEMI, 2.2K N		4080429607	LED BT-603W-30
	6450035579	VR, SEMI, 2.2K N	D1901A	6102645064	HOLDER LED-S2CP
				6102737929	HOLDER LED-S4KF
TRANSFORMER				6103039954	HOLDER LED-C4LA
T431	6450473371	TRANS, DRIVE	D249	4070996023	ZENER DIODE MTZJ9.1B
	6520000704	TRANS, DRIVE		4070579711	ZENER DIODE RD9.1EB2
△ T471	6520018532	TRANS, FLYBACK	D352	4070638626	ZENER DIODE MTZJ5.1A
△ T611	6450881541	TRANS, POWER, PULSE		4070567916	ZENER DIODE RD5.1EB1
				4080476403	ZENER DIODE MTZJ5.1A
COIL			D353	4070995224	ZENER DIODE MTZJ5.1B
L431	6450261084	INDUCTOR, 1U K	D357	4080093204	DIODE 1N4148
L432	6450187025	CORE, PIPE		4070124426	DIODE 1SS133
	6520010475	PIPE CORE		4070134336	DIODE 1S2076A
L441	6450642654	COIL, LINEARITY	D3701	4070058632	DIODE ERA15-02-V1
L442	6450580444	INDUCTOR, 145U		4080456801	DIODE ERA15-02
L461	6100311367	INDUCTOR 202J	D421	4070997228	ZENER DIODE MTZJ16A
	6102113488	INDUCTOR		4070547027	ZENER DIODE RD16EB1
	6450055645	INDUCTOR, 2200U K		4070547215	ZENER DIODE RD16EB3
	6450078361	INDUCTOR, 2000U	D438	4070958001	DIODE ERD07-15L
	6520000742	INDUCTOR, 2.0MH	D439	4070064128	DIODE ERB44-04V1
L462	6450002229	INDUCTOR 430UH	D461	4080093204	DIODE 1N4148
	6450597138	INDUCTOR, 438U		4070124426	DIODE 1SS133
△ L601	6450193873	LINE FILTER		4070134336	DIODE 1S2076A
	6520001961	LINE FILTER	D465	4080093204	DIODE 1N4148
L602	6101975711	CUTTING WIRE		4070124426	DIODE 1SS133
L603	6101975711	CUTTING WIRE		4070134336	DIODE 1S2076A
L632	6101975711	CUTTING WIRE	D466	4070997822	ZENER DIODE MTZJ20A
L635	6101975711	CUTTING WIRE	D467	4080093204	DIODE 1N4148
				4070134336	DIODE 1S2076A
DIODE			D468	4080093204	DIODE 1N4148
D004	4072128818	DIODE KDS160-RTK		4070124426	DIODE 1SS133

Ref. No.	Part No.	Description	Ref. No.	Part No.	Description	
D469	4070134336	DIODE 1S2076A	SW1901	6450034701	SWITCH,PUSH 1P-1TX1	
	4070077415	DIODE EU1		6450194887	SWITCH,PUSH 1P-1TX1	
	4080614102	DIODE EU1	SW1902	6450034701	SWITCH,PUSH 1P-1TX1	
D476	4070638329	ZENER DIODE MTZJ11C		6450194887	SWITCH,PUSH 1P-1TX1	
	4070541827	ZENER DIODE RD11EB3	SW1903	6450034701	SWITCH,PUSH 1P-1TX1	
D485	4070077415	DIODE EU1		6450194887	SWITCH,PUSH 1P-1TX1	
	4080614102	DIODE EU1	SW1904	6450034701	SWITCH,PUSH 1P-1TX1	
D489	4070995828	ZENER DIODE MTZJ7.5A		6450194887	SWITCH,PUSH 1P-1TX1	
	4080478803	ZENER DIODE MTZJ7.5A	SW1905	6450034701	SWITCH,PUSH 1P-1TX1	
D512	4070058632	DIODE ERA15-02-V1		6450194887	SWITCH,PUSH 1P-1TX1	
	4080456801	DIODE ERA15-02	SW1906	6450034701	SWITCH,PUSH 1P-1TX1	
D605	4070066310	DIODE ERC05-10BV1		6450194887	SWITCH,PUSH 1P-1TX1	
	4070096921	DIODE RM11C	△ SW601	6450590061	SWITCH, POWER 1P-1TX1	
	4080614003	DIODE ERC05-10B	△ VA601	4071712008	VARISTOR ERZV14D471	
D606	4070066310	DIODE ERC05-10BV1		4072471300	VARISTOR SVC471D-07ABW7	
	4070096921	DIODE RM11C	X161	4210121906	SAW F TSF6376BL	
	4080614003	DIODE ERC05-10B		4210115202	SAW F TSF6376Y	
D607	4070066310	DIODE ERC05-10BV1	X211	6450248818	OSC,CRYSTAL 4.433619MHZ	
	4070096921	DIODE RM11C		6450820052	OSC,CRYSTAL 4.433619MHZ	
	4080614003	DIODE ERC05-10B		6520010154	OSC,CRYSTAL 4.433619MHZ	
D608	4070066310	DIODE ERC05-10BV1	X801	6450041938	OSC,CRYSTAL 32.768KHZ	
	4070096921	DIODE RM11C	6103346298 ASSY,PWB,CRT BA4H 1AA0B10S218KB			
	4080614003	DIODE ERC05-10B				
D609	4080093204	DIODE 1N4148				
△ D610	4072348701	PHOTO COUPLE PC123X5YFZ	TRANSISTOR			
	4072303908	PHOTO COUPLE PC123Y52	Q701	4052188115	TR KTC3229-U/P	
	4072317707	PC TLP421F(D4-BL)		4060099509	TR 2SC4544	
D611	4071468113	DIODE EG01C	Q703	4052188115	TR KTC3229-U/P	
	4080618803	DIODE EG01C		4060099509	TR 2SC4544	
D612	4070077415	DIODE EU1	Q705	4052188115	TR KTC3229-U/P	
	4080614102	DIODE EU1		4060099509	TR 2SC4544	
D613	4070077415	DIODE EU1	Q721	4051413515	TR KTA1266-Y-T	
	4080614102	DIODE EU1		4060087407	TR 2SA1015-G(SAN)-TPE2	
D614	4070995422	ZENER DIODE MTZJ6.2B		4050017417	TR 2SA1015-O(SAN)	
D631	4070098816	DIODE RU3AM		4050017615	TR 2SA1015-Y(SAN)	
	4080584405	DIODE RU3AM		4050061717	TR 2SA933S-Q	
D632	4071662303	DIODE ERC91-02		4050061816	TR 2SA933S-R	
D633	4070077613	DIODE EU2	CAPACITOR			
	4080458102	DIODE EU2Z	C703	4030745722	CERAMIC 560P K 50V	
D634	4070098915	DIODE RU3M	C705	4030745722	CERAMIC 560P K 50V	
	4080614201	DIODE RU3M	C707	4030745722	CERAMIC 560P K 50V	
D661	4070540018	ZENER DIODE RD10EB2	C708	4041119707	CERAMIC 470P K 2K	
D681	4080093204	DIODE 1N4148		4040862109	CERAMIC 470P K 2K	
	4070124426	DIODE 1SS133		4032454404	CERAMIC 470P K 2K	
	4070134336	DIODE 1S2076A		4032758106	CERAMIC 470P K 2K	
D686	4070995521	ZENER DIODE MTZJ6.2C		4034140414	CERAMIC 470P K 2K	
	4070572831	ZENER DIODE RD6.2EB3		C710	4033531401	ELECT 10U M 250V
D687	4070638923	ZENER DIODE MTZJ5.6C	RESISTOR			
	4080477608	ZENER DIODE MTZJ5.6C	R701	4010269630	CARBON 470 JA 1/6W	
D688	4080093204	DIODE 1N4148	R702	4010253837	CARBON 180 JA 1/6W	
	4070124426	DIODE 1SS133	R704A	4010269630	CARBON 470 JA 1/6W	
	4070134336	DIODE 1S2076A	R705	4010253837	CARBON 180 JA 1/6W	
MISCELLANEOUS			R707A	4010269630	CARBON 470 JA 1/6W	
△ F601	4240059507	FUSE 250V 4A	R708	4010253837	CARBON 180 JA 1/6W	
	4230288603	FUSE 250V 4A	R711	4010654604	OXIDE-MT 12K JA 2W	
F601A	6450705434	HOLDER,FUSE	R712	4010654604	OXIDE-MT 12K JA 2W	
F601B	6450705434	HOLDER,FUSE	R713	4010654604	OXIDE-MT 12K JA 2W	
A101	6450904059	TUNER, U/V	R715	4010091528	CARBON 2.7K JA 1/2W	
A1901	6450411519	UNIT,REMOCON RECEIVER	R716	4010091528	CARBON 2.7K JA 1/2W	
	6450440519	UNIT,REMOCON RECEIVER	R717	4010091528	CARBON 2.7K JA 1/2W	
	6450614309	UNIT,REMOCON RECEIVER	R723	4010272333	CARBON 560 JA 1/6W	
K1001	6450064791	JACK,PHONE D3.6	R724	4010249335	CARBON 1.2K JA 1/6W	
	6520010970	JACK,PHONE D3.5	R732	4010246433	CARBON 10 JA 1/6W	
K1003	6520015401	JACK,RCA-3				
K1101	6520016187	JACK,RCA-9				
△ PS601	4080465407	TH PTDCA1BF4R5Q200				

Ref. No.	Part No.	Description	Ref. No.	Part No.	Description
R743	4010272630	CARBON 5.6K JA 1/6W			
COIL					
L702	6450079481	INDUCTOR,100U J			
	6450079504	INDUCTOR,100U K			
MISCELLANEOUS					
△K701L	6450262005	SOCKET,CRT 8P			
	6450317699	SOCKET,CRT 8P			
	6520017726	SOCKET,CRT 8P			

Component Locations

Main Board (Parts Side)

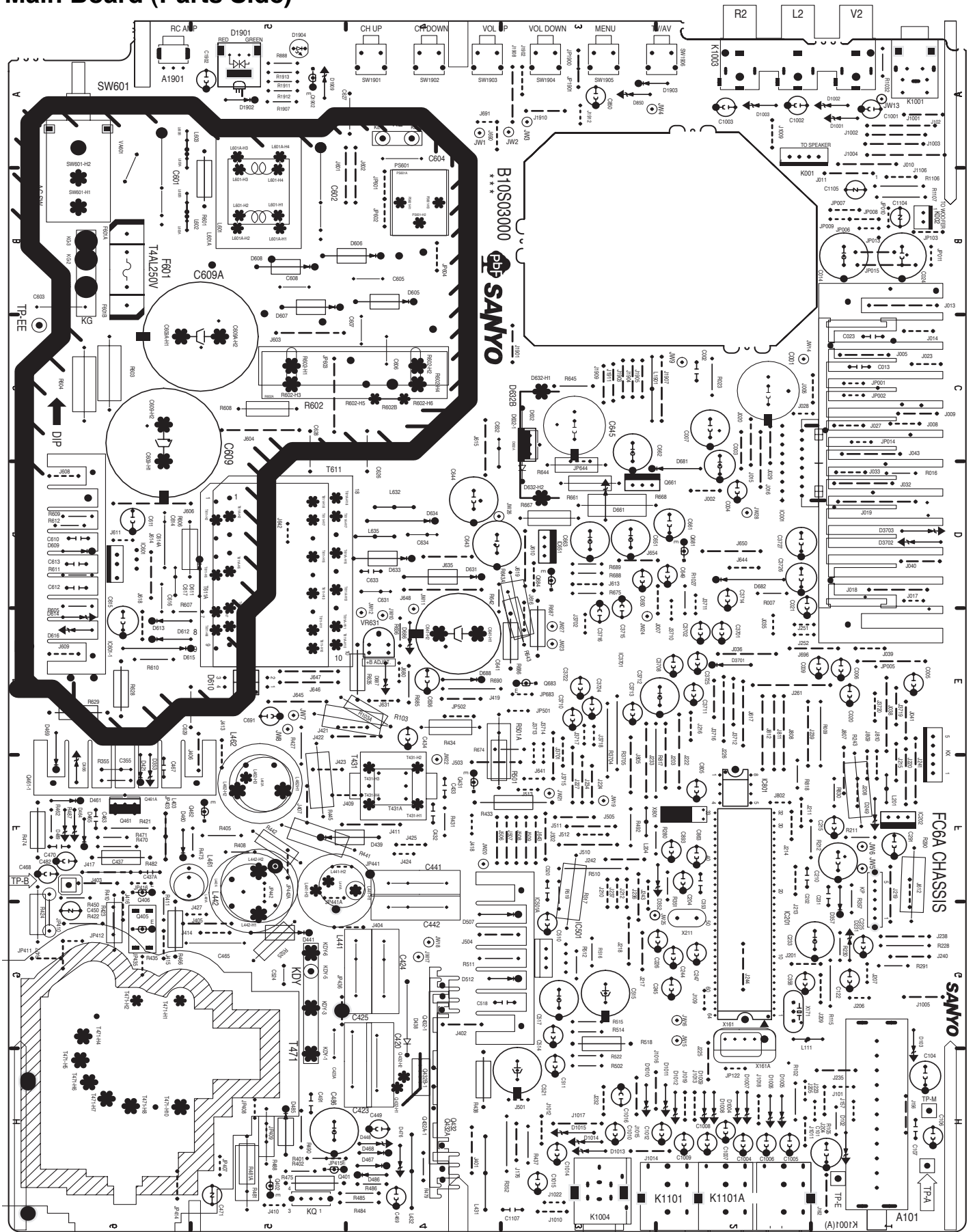

Component Locations

Main Board (Solder Side)

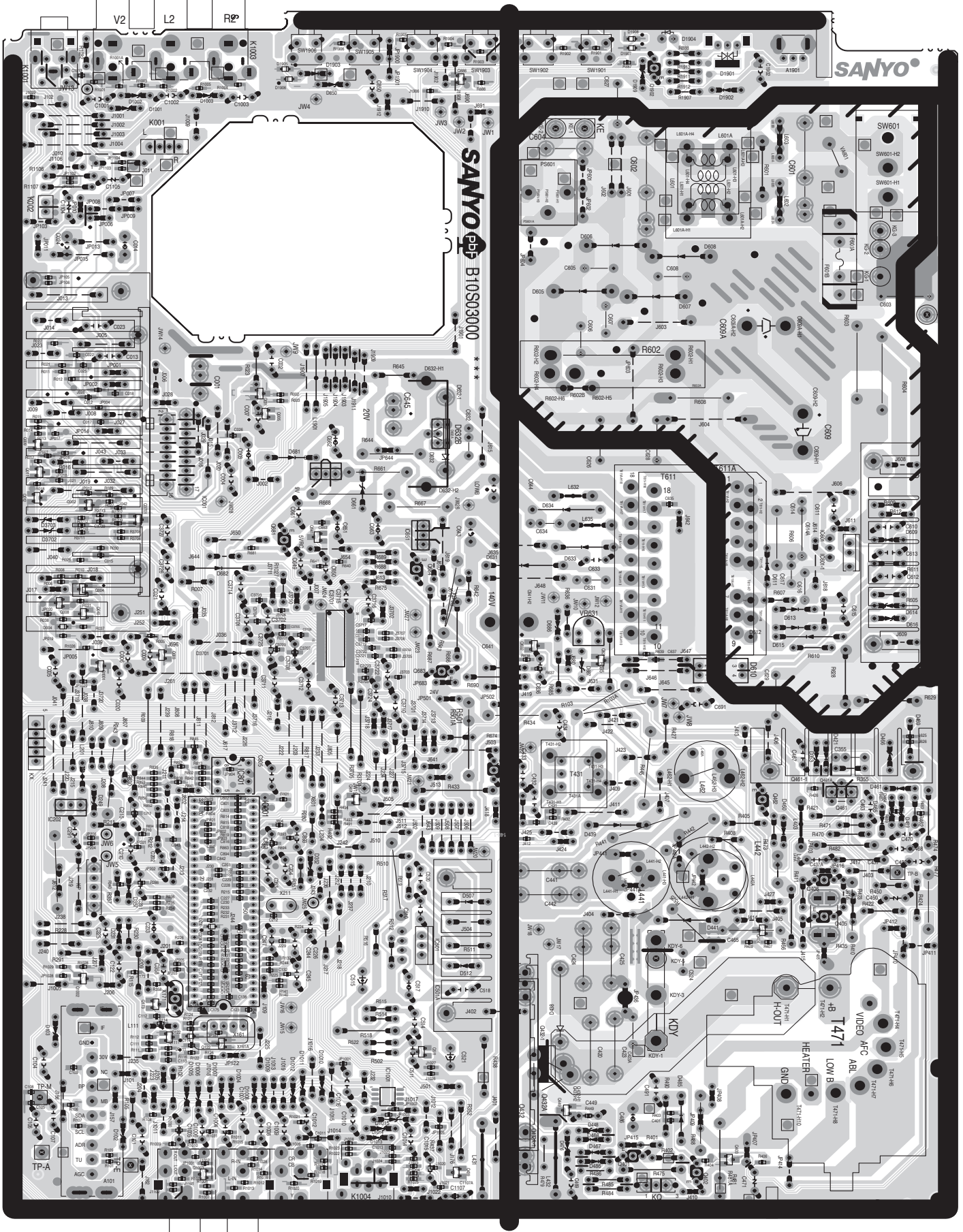

Component Locations

CRT Board (Parts Side)

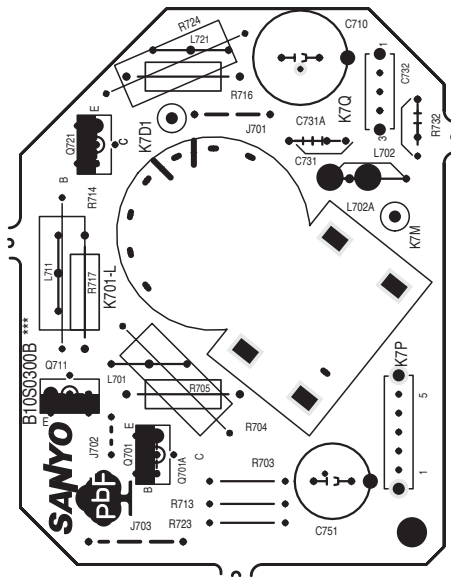

CRT Board (Solder Side)

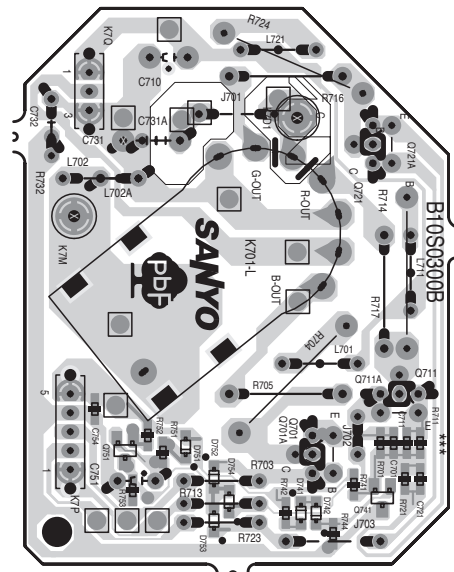

Voltages and Waveforms Charts

Note: Voltages and waveforms were measured with colour bar signal and controls adjusted for normal picture.

Main Board

Q003 E 0V C 0.5V B 0V	Q004 E 0V C 0V B 0.6V	Q008 E 0V C 0V B 0.5V	Q010 E 8.8V C 0V B 8.9V	Q011 E 0V C 19.8V B 0V	Q1001 E 4.1V C 0V B 3.2V	Q1002 E 4.1V C 0V B 3.2V	Q1003 E 2.6V C 0V B 1.9V	Q111 E 0.4V C 5.5V B 1.2V	Q122 E 0V C 0V B 0.6V	Q1902 E 4.9V C 0V B 4.9V	Q431 E 0V C 10.6V B 0V
Q432 E 0V C 354V B 1.3V	Q439 E 1.6V C 4V B 1.6V	Q461 E 10.4V C 0V B 11.1V	Q462 E 0V C 10.5V B 0.6V	Q491 E 3V C 0V B 2.3V	Q511 E 0V C 4.9V B 0V	Q631 E 6.3V C 0V B 6.8V	Q632 E 0V C 7.8V B 0V	Q641 E 4V C 5V B 4.7V	Q661 E 9.7V C 9.9V B 9.1V	Q681 E 0V C 9.7V B 0V	Q683 E 26V C 26.6V B 25.9V
Q684 E 0V C 0V B 0V	Q886 E 0V C 0V B 0.7V										

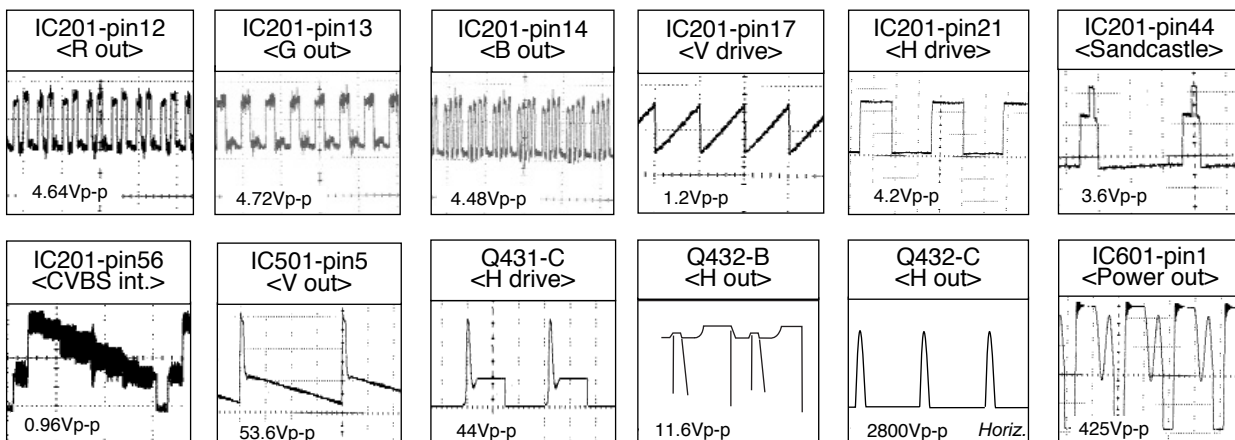

Voltages and Waveforms Charts

IC001 (AUDIO AMP.)																	
Pin-1	10.4V	2	0V	3	21V	4	0.4V	5	0V	6	0V	7	0V	8	3.2V	9	3.2V
10	19.7V	11	11.9V	12	3.2V	13	3.2V	14	10.4V	15	0V	16	0V	17	10.5V		
IC501 (VERT. OUT)																	
Pin-1	2.4V	2	26.3V	3	1.4V	4	GND	5	12.5V	6	25.5V	7	2.4V				
IC601 (POWER)																	
Pin-1	32V	2	N.C.	3	GND	4	20.9V	5	0V	6	1.2V	7	0.5V				
IC651 (5VRC)				IC202 (5V1)													
Pin-1	11.5V	2	GND	3	5V	Pin-1	6.5V	2	GND	3	4.9V						
IC801 (MEMORY)																	
Pin-1	GND	2	GND	3	GND	4	GND	5	4.9V	6	4.9V	7	0V	8	4.9V		
IC3701 (AUDIO CONTROL)																	
Pin-1:	GND	2:	4.1V	3:	4.1V	4:	4.1V	5:	3.5V	6:	4.1V	7:	4.1V	8:	4.1V	9:	4.1V
10:	4.1V	11:	4.1V	12:	4.1V	13:	4.1V	14:	4.1V	15:	4.0V	16:	4.2V	17:	8.3V	18:	3.0V
19:	3.5V	20:	3V	21:	0V	22:	4.1V	23:	4.1V	24:	4.1V	25:	4.1V	26:	4.1V	27:	4.1V
28:	4.1V	29:	4.7V	30:	4.1V	31:	4.1V	32:	3.5V	33:	4.1V	34:	4.1V	35:	4.2V	36:	4.1V
IC201 (CPU/IF/VIDEO/CHROMA/DEF)																	
Pin-1:	2.5V	2:	2.6V	3:	3V	4:	2.3V	5:	2.4V	6:	2.4V	7:	2V	8:	5V	9:	2.4V
10:	3.4V	11:	8.4V	12:	3.2V	13:	3.2V	14:	3.2V	15:	1.2V	16:	2V	17:	2.4V	18:	1.7V
19:	5V	20:	2.7V	21:	2.7V	22:	GND	23:	5V	24:	5V	25:	5V	26:	4.8V	27:	5V
28:	5V	29:	5V	30:	0V	31:	4.3V	32:	4V	33:	0.4V	34:	2.5V	35:	5V	36:	4.9V
37:	0V	38:	5V	39:	0V	40:	3.9V	41:	3.3V	42:	GND	43:	4.5V	44:	1.4V	45:	2.4V
46:	2.6V	47:	2.4V	48:	2.5V	49:	0V	50:	2.8V	51:	0V	52:	2.6V	53:	3.2V	54:	2.6V
55:	5V	56:	2.8V	57:	0V	58:	2.5V	59:	2.4V	60:	2.3V	61:	1.8V	62:	GND	63:	2.9V
64:	2.9V																

CRT Board

Q701 E 2.5V C 4.0V B 2.6V	Q711 E 2.5V C 11V B 2.6V	Q721 E 2.5V C 14.6V B 2.6V	Q741 E 1.7V C 0V B 1V	Q751 E 8.9V C 0V B 9V
-------------------------------------------	------------------------------------------	--------------------------------------------	---------------------------------------	---------------------------------------

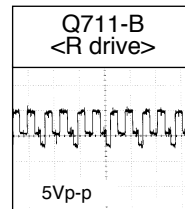
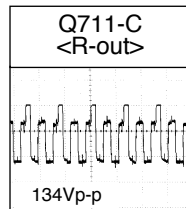
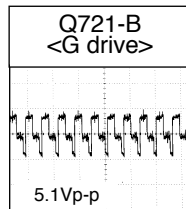
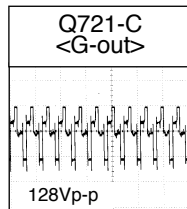
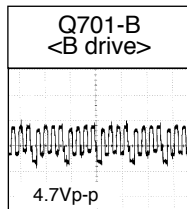
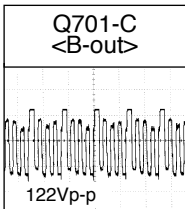





SANYO Electric Co., Ltd.
Printed in Russia

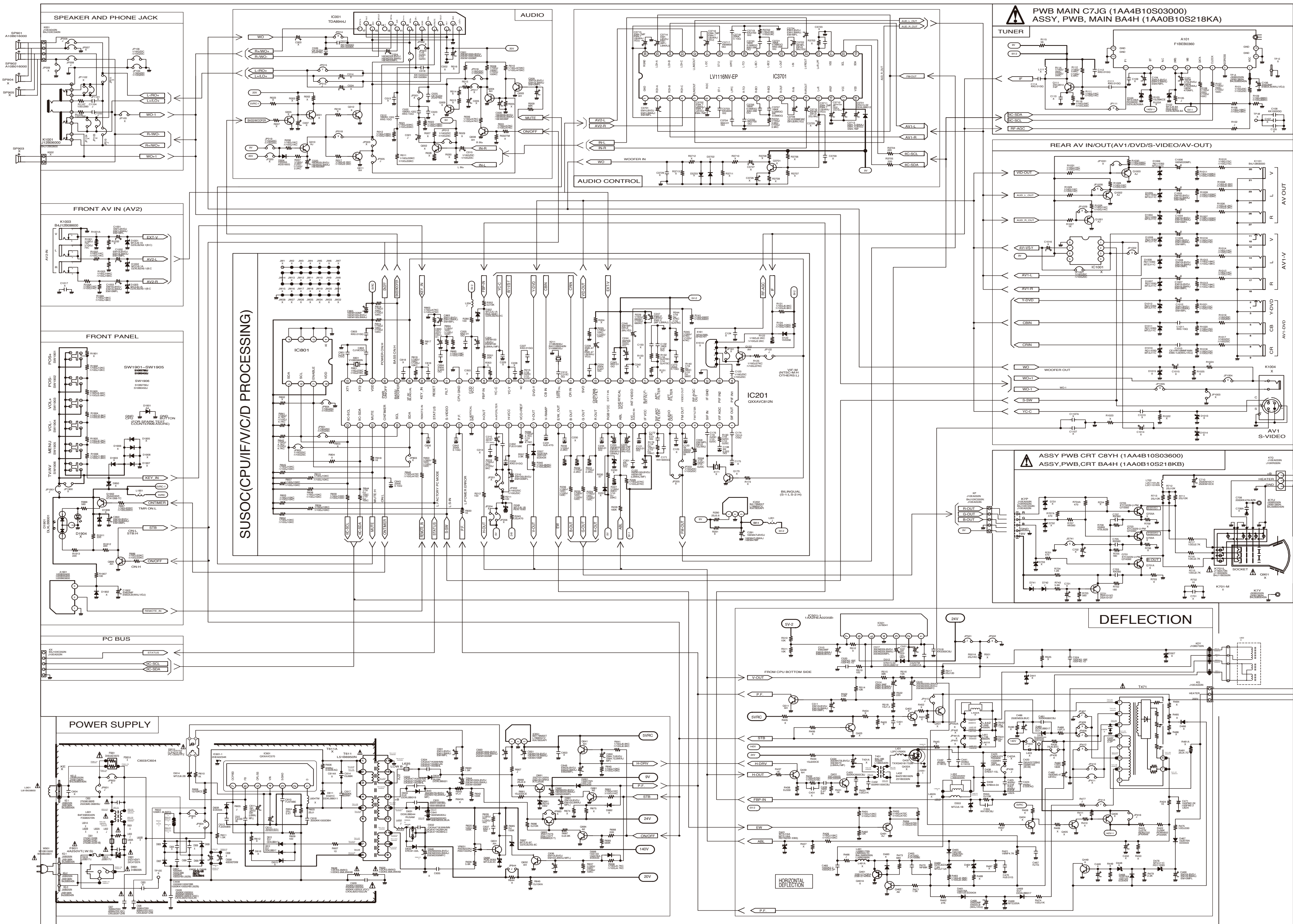

LIST OF REPLACEABLE TRANSISTORS

2S4000S TYPE	14TH CODE	2S4000S	2S4010S	2S4040A
AB	7F50018T	R	VGR	R
AE	7F50018P	GM	QYGR	GM
2S4030V CRSP TYPE				
14TH CODE	2S4119	2S4107	2S4107	
AE	7F50020T	R	RLR	RLR
2S4120S TYPE				
14TH CODE	2S4148B	2S4158A	2S4171A	
AE	7F50018S	QJAS	GAFA	YGR
AE	7F50020P	QJRS	RACOPA	OYGR
2S4170S CRSP TYPE				
14TH CODE	2S4212	2S4212K		
AE	7F50020S	LELY	RLS	

LIST OF REPLACEABLE DIODES

DIODE CODE	DIODE NAME
AA	2S4000S 1S4000S 1S4000S 1S4000S 1S4000S
AA	2S4000S 1S4000S 1S4000S 1S4000S 1S4000S
AA	2S4000S 1S4000S 1S4000S 1S4000S 1S4000S
AA	2S4000S 1S4000S 1S4000S 1S4000S 1S4000S

THE SERVICE PRECAUTION:
The area enclosed by this line () is directly connected with AC mains voltage. When servicing the area, connect an isolating transformer between TV receiver and AC line to eliminate hazard of electric shock.

PRODUCT SAFETY NOTICE:
Product safety should be considered when a component replacement is made in any area of a receiver. Components indicated by a mark Δ in this circuit diagram show components whose values have special significance to product safety. It is particularly recommended that only parts specified on the part service manual be used for components replacement pointed out by the mark.

CIRCUIT DIAGRAM NOTICE:

- All resistance value are in ohms, K=1,000, M=1,000,000.
- All resistance rated wattages are 1/6W unless otherwise noted.
- Excepting electrolytic capacitors, all capacitance values of less than 1 are expressed in μ F and more than 1 are pF.
- All capacitance rated voltages are 50V unless otherwise noted.
- All inductance values are in μ H.
- Voltage readings take with a "VTVM" are from point indicated chassis ground. Voltage readings taken by using PAL colour bar signal are with all controls at normal position. Some voltage may vary with signal strength.
- Waveform were taken with PAL colour bar and controls adjusted for normal picture. Waveforms were taken by using a wide band oscilloscope and a low capacity probe.
- This circuit diagram covers a basic or representative chassis only. There may be some components or partial circuit differences between the actual chassis and the circuit diagram.
- Parts specified with "X" are not installed in this model.
- Parts specified with "J" are just jumper wires.

11. Expression of capacitance and resistance in circuit diagram.

Capacitance (Example)
1000 C M 2000 D

Resistance (Example)
1/2 N J 1.2

Characteristics:
J = $\pm 5\%$
K = $\pm 10\%$
M = $\pm 20\%$

Capacitance value (220pF)
Allowable error ($\pm 20\%$)
Kind (Ceramic)
Rated voltage (1,000V)

Resistance value (1.2 Ω)
Allowable error ($\pm 5\%$)
Kind (M, carbon)
Rated wattage (1/2W)

Material codes:
T, A, U, D: Electrolytic
C, K, B: Ceramic
F: Mylar film
M, N: Polypropylene
Z: Metallized paper

Other codes:
D: Carbon
N: Metallized carbon
S: Oxidized metal
W: Wire winding
C: Solid

COLOUR TELEVISION
FC6-A CHASSIS SERIES
SERVICE REF. NO. **CE29EF1-00**

