

10 Schematic Diagrams

10-1 SMPS Part Schematic Diagram

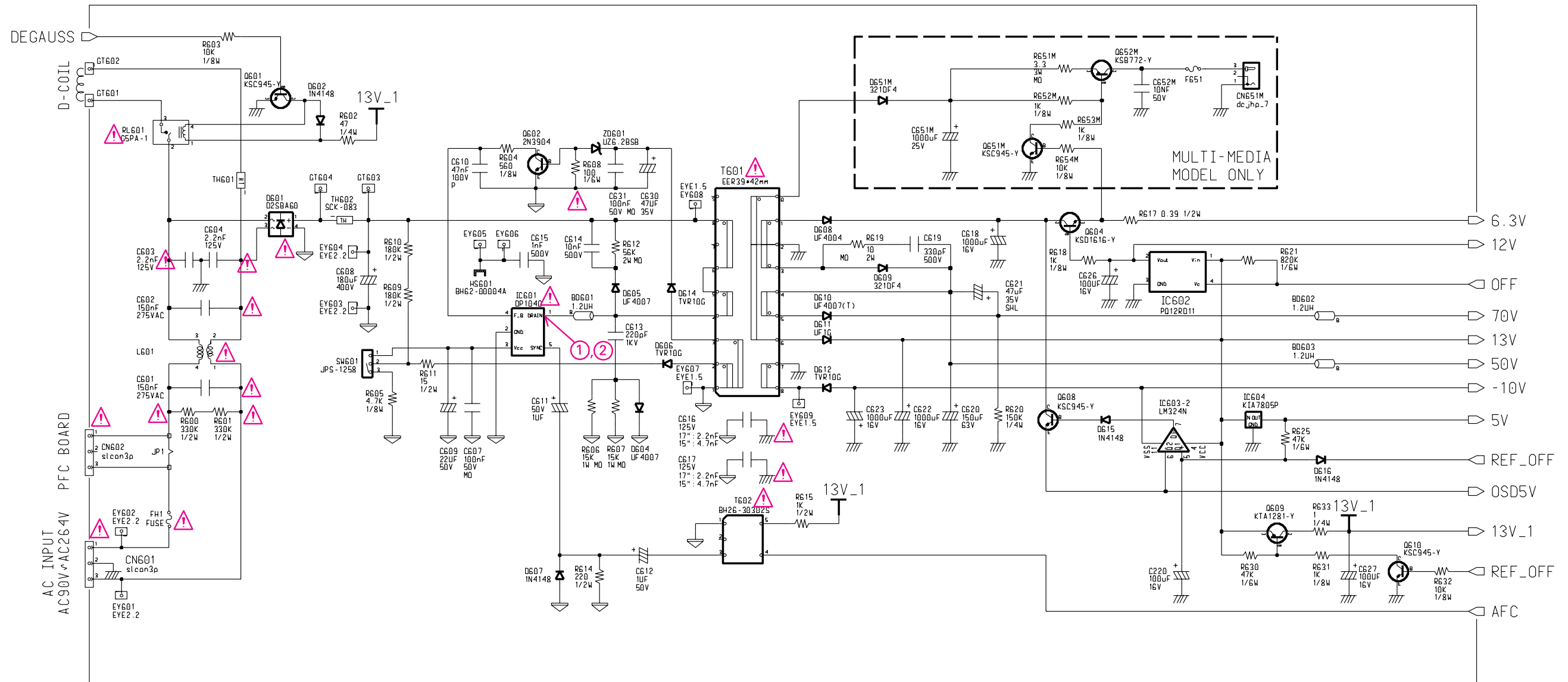

Table 10-1. IC601 (DP104C)

pin #	MODES	
	1024 x 768 / 85 Hz	640 x 480 / 60 Hz
1	285 V	286 V
2	0.8 mV	0.6 mV
3	18.1 V	18.0 V
4	1.51 V	2.01 V
5	4.98 V	4.98

Unit: Vrms

Table 10-2. IC602 (78R12)

pin #	MODES	
	1024 x 768 / 85 Hz	640 x 480 / 60 Hz
1	13.57 V	13.50
2	12.05	12.05
3	-17.0 mV	-15.5 mV
4	4.99 V	4.99 V

Unit: Vrms

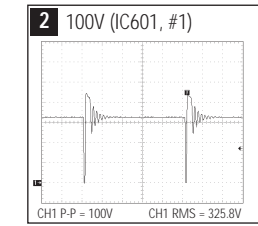
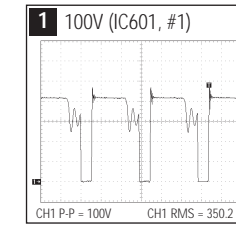

10-2 Micom Part Schematic Diagram

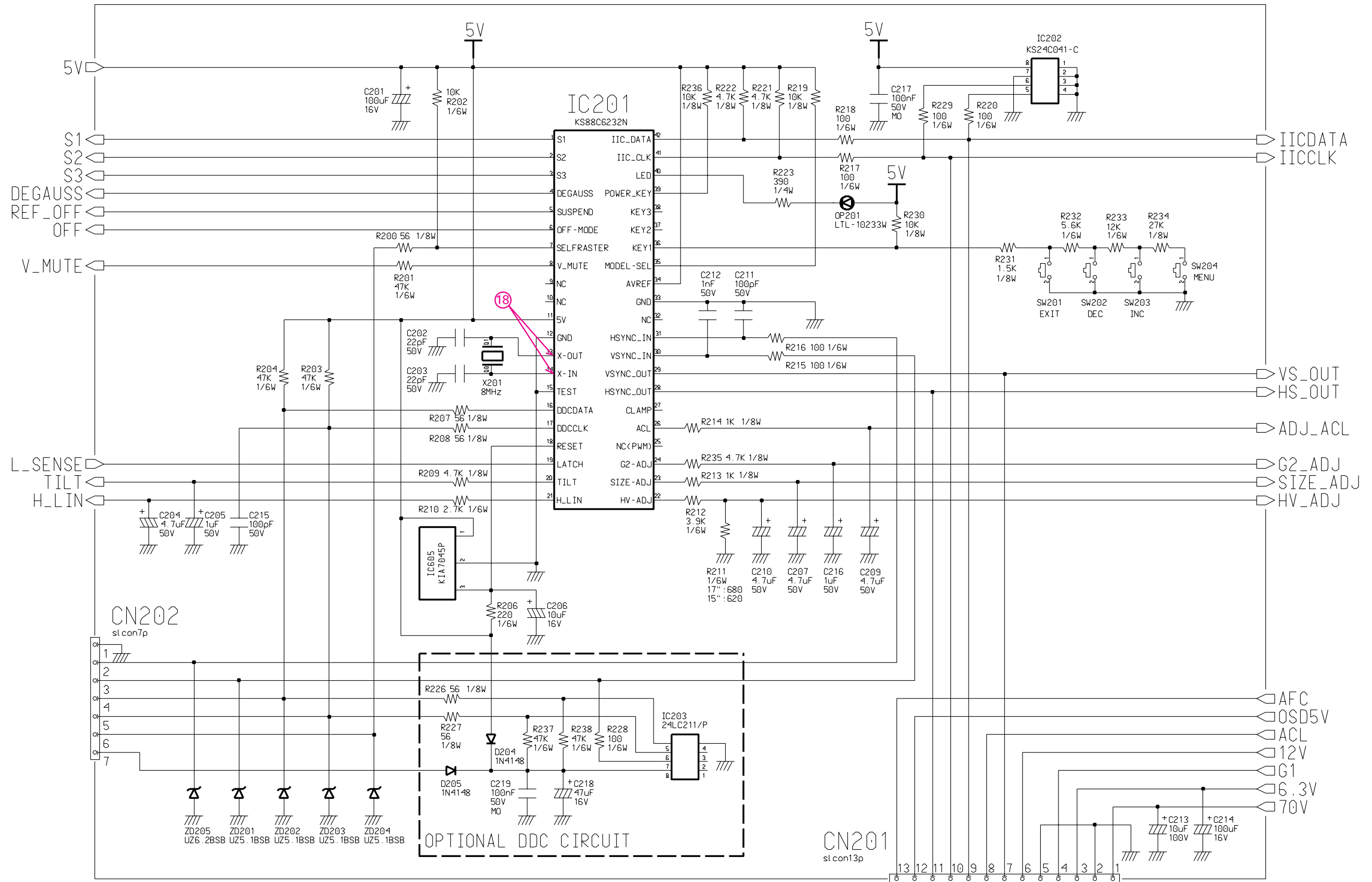
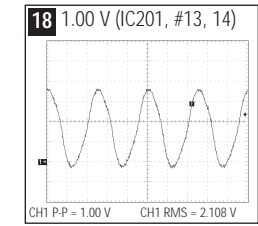

Table 10-3. IC201 (KS88C6231N)

pin #	MODES		pin #	MODES	
	1024 x 768 / 85 Hz	640 x 480 / 60 Hz		1024 x 768 / 85 Hz	640 x 480 / 60 Hz
1	5.01 V	0.47 mV	22	1.02 V	1.02 V
2	5.01 V	-2.0 mV	23	2.91 V	0.31 V
3	5.01 V	-3.2 mV	24	1.14 V	1.04 V
4	-4.9 mV	-4.4 mV	25	7.5 mV	-8.7 mV
5	5.00 V	5.00 V	26	3.99 V	3.99 V
6	4.9 V	4.90 V	27	4.93 V	5.0 V
7	31.2 mV	30.8 mV	28	4.73 V	4.49 V
8	7.96 mV	-7.4 mV	29	11.3 mV	-11.4 mV
9	9.1 mV	-8.5 mV	30	4.5 mV	4.49 V
10	9.9 mV	-9.4 mV	31	0.314 V	3.98 V
11	5.12 V	5.12 V	32	15.3 mV	-14.6 mV
12	15.3 mV	-14.5 mV	33	15.6 mV	-14.8 mV
13	1.13 V	1.13 V	34	5.12 V	5.12 V
14	1.68 V	1.70 V	35	5.11 V	5.11 V
15	15.5 mV	-14 mV	36	5.11 V	5.11 V
16	4.13 mV ~ 3.9 V	41.3 V ~ 3.9 V	37	5.11 V	5.11 V
17	3.66 V	3.67 V	38	5.11 V	5.11 V
18	4.99 V	4.99 V	39	5.11 V	5.11 V
19	4.31 V	4.34 V	40	0.145 V	0.146 V
20	2.49 V	2.49 V	41	5.12 V	5.12 V
21	2.44	0.6 V	42	5.12	5.12 V

Unit: Vrms



10-3 HV OSC & Vertical Part Schematic Diagram

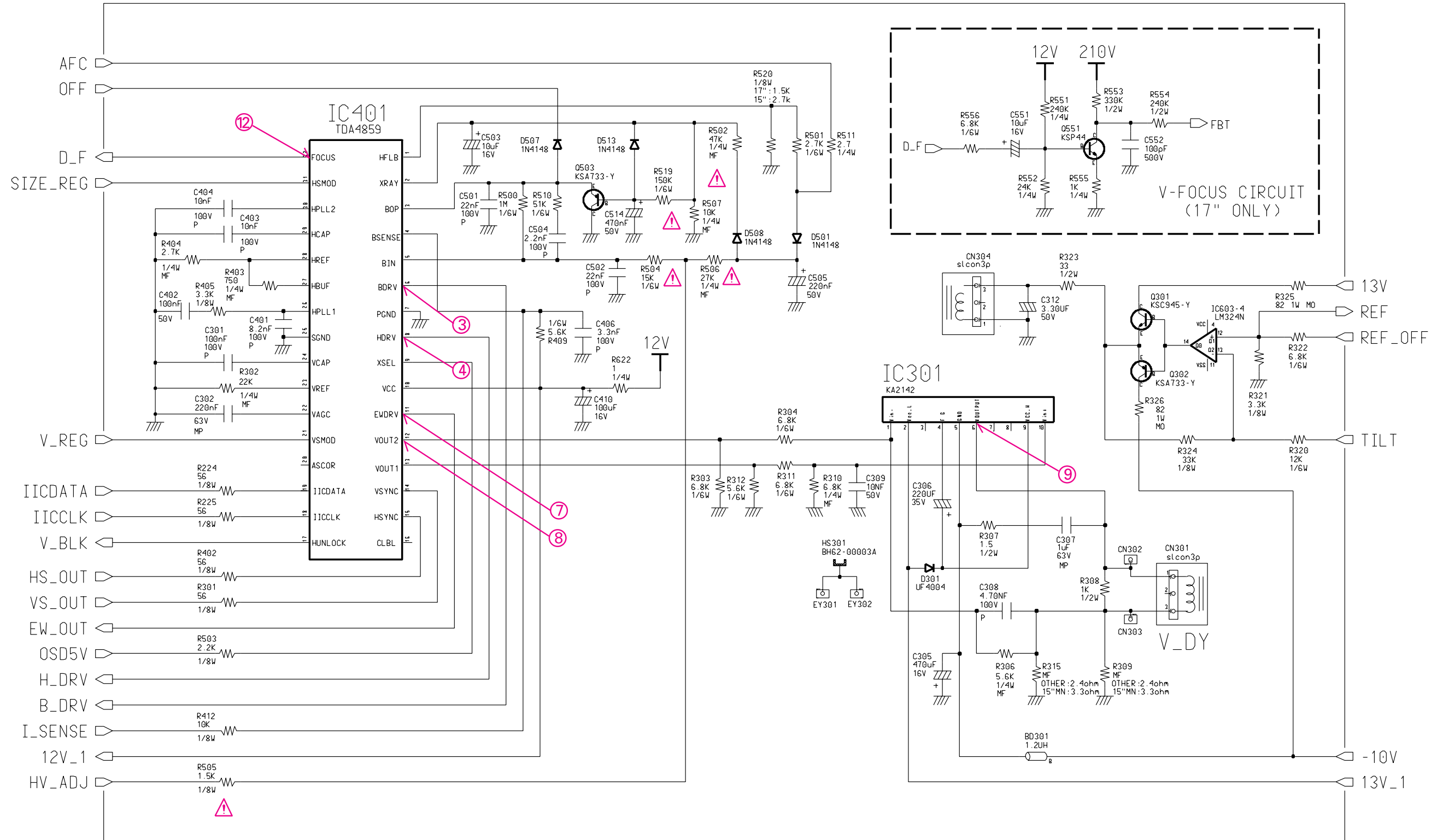

Table 10-5. IC301 (KA2142)

pin #	MODES	
	800 x 600 / 85 Hz	640 x 480 / 60 Hz
1	0.64	0.64
2	13.2	13.0
3	1.5 mV	0.1 mV
4	-10.5	-10.6
5	-11.0	-10.9
6	-3.9 mV	-1.6 mV
7	0 mV	0.1 mV
8	0.1 mV	0.1 mV
9	12.9 V	12.6 V
10	0.64 V	0.64 V

Unit: Vrms

Table 10-6. IC603 (LM324N)

pin #	MODES	
	1024 x 768 / 85 Hz	640 x 480 / 60 Hz
1	12.01	11.8
2	3.06	3.60
3	5.12	5.12
4	13.5	13.3
5	5.12	5.11
6	5.12	5.12
7	6.51	6.43
8	0.66	3.96
9	1.63	1.63
10	1.63	1.63
11	11.19	-11.1
12	1.63	1.63
13	1.63	1.63
14	0.70	-0.68

Unit: Vrms

Table 10-7 IC401 (TDA4859)

pin #	MODES		pin #	MODES	
	1024 x 768 85 Hz	640 x 480 / 60 Hz		1024 x 768 85 Hz	640 x 480 / 60 Hz
1	0.33 V	-0.15 V	17	24.7 mV	23.9 mV
2	5.64 V	5.68 V	18	5.12 V	5.12 V
3	4.45 V	3.89 V	19	5.12 V	5.12 V
4	2.15 V	1.39 V	20	4.02 V	4.04 V
5	2.48 V	2.48 V	21	5.01 V	5.01 V
6	3.54 V	6.48 V	22	2.69 V	3.17 V
7	-15.4 mV	-14.5 mV	23	3.02 V	3.03 V
8	0.964 V	0.93 V	24	2.66	2.67 V
9	2.01 V	2.02 V	25	-15.4 mV	-14.7 mV
10	11.7 V	11.7 V	26	3.86 V	3.86 V
11	2.73 V	1.86 V	27	1.54 V	2.51 V
12	1.38 V	1.38 V	28	2.57 V	2.56V
13	1.29 V	1.29 V	29	4.54 V	4.51 V
14	-11.3 mV	-11.4 mV	30	5.47 V	5.00 V
15	4.73 V	4.49 V	31	5.47 V	4.99
16	0.76 V	0.64 V	32	6.11 V	6.08

Unit: Vrms

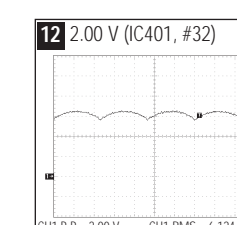
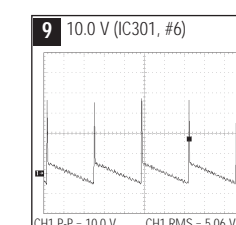
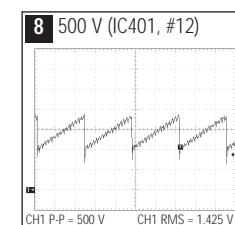
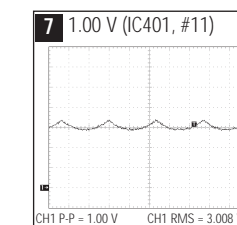
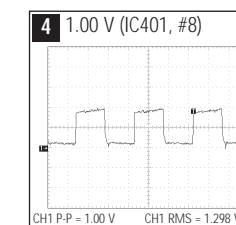
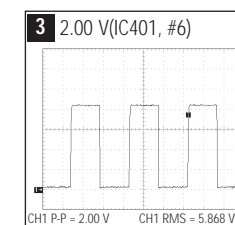

10-4 Deflection Part Schematic Diagram

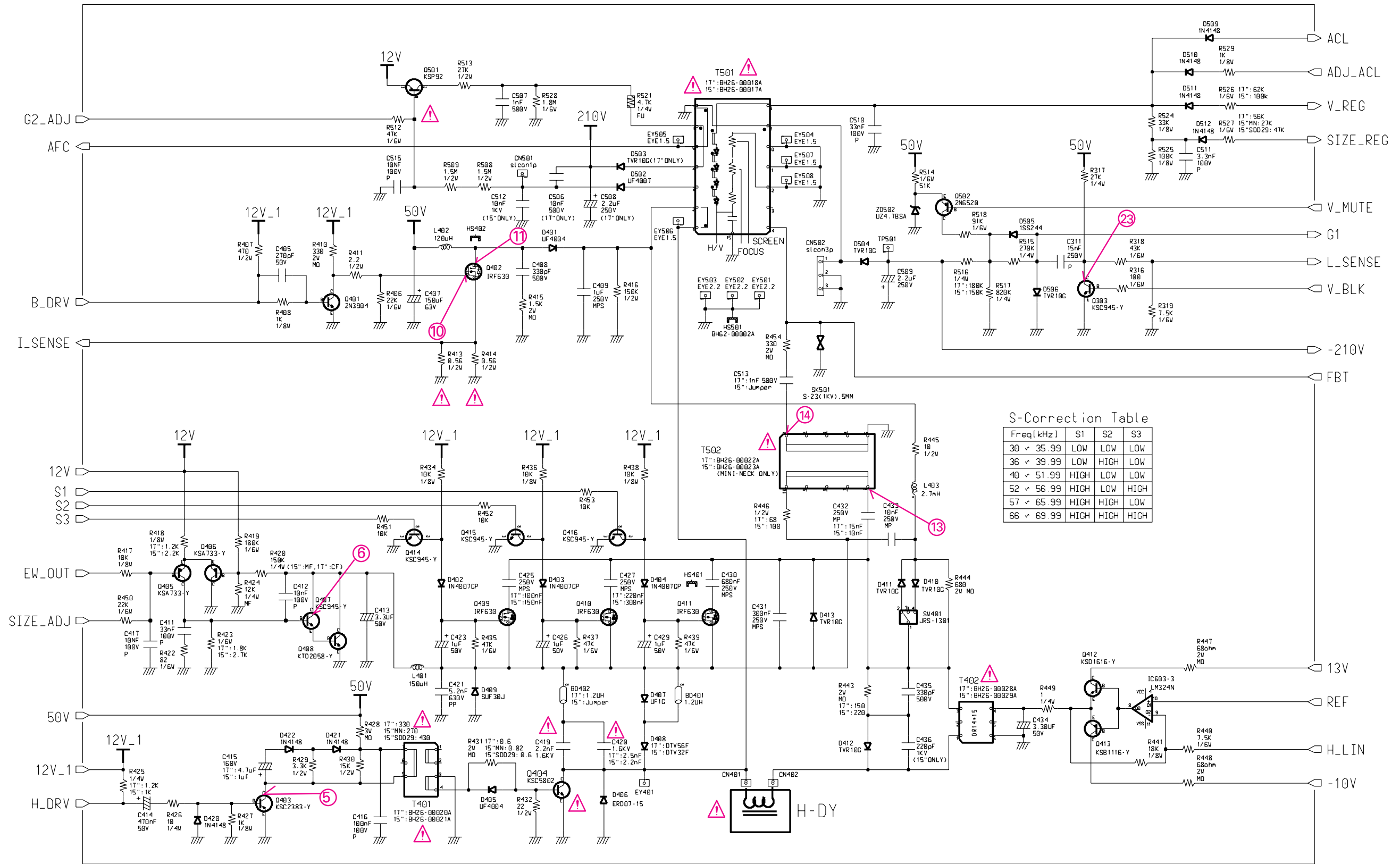

S-Connection Table

Freq[kHz]	S1	S2	S3
30 ~ 35.99	LOW	LOW	LOW
36 ~ 39.99	LOW	HIGH	LOW
40 ~ 51.99	HIGH	LOW	LOW
52 ~ 56.99	HIGH	LOW	HIGH
57 ~ 65.99	HIGH	HIGH	LOW
66 ~ 69.99	HIGH	HIGH	HIGH

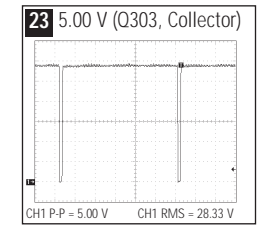
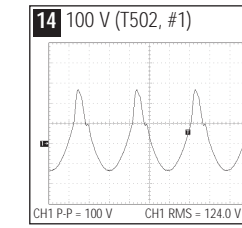
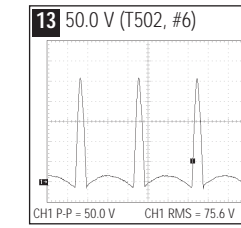
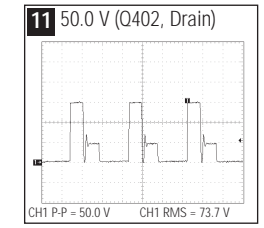
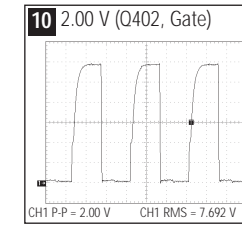
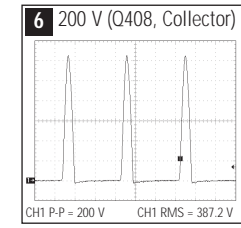
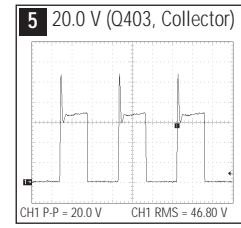

10-5 Video Part Schematic Diagram

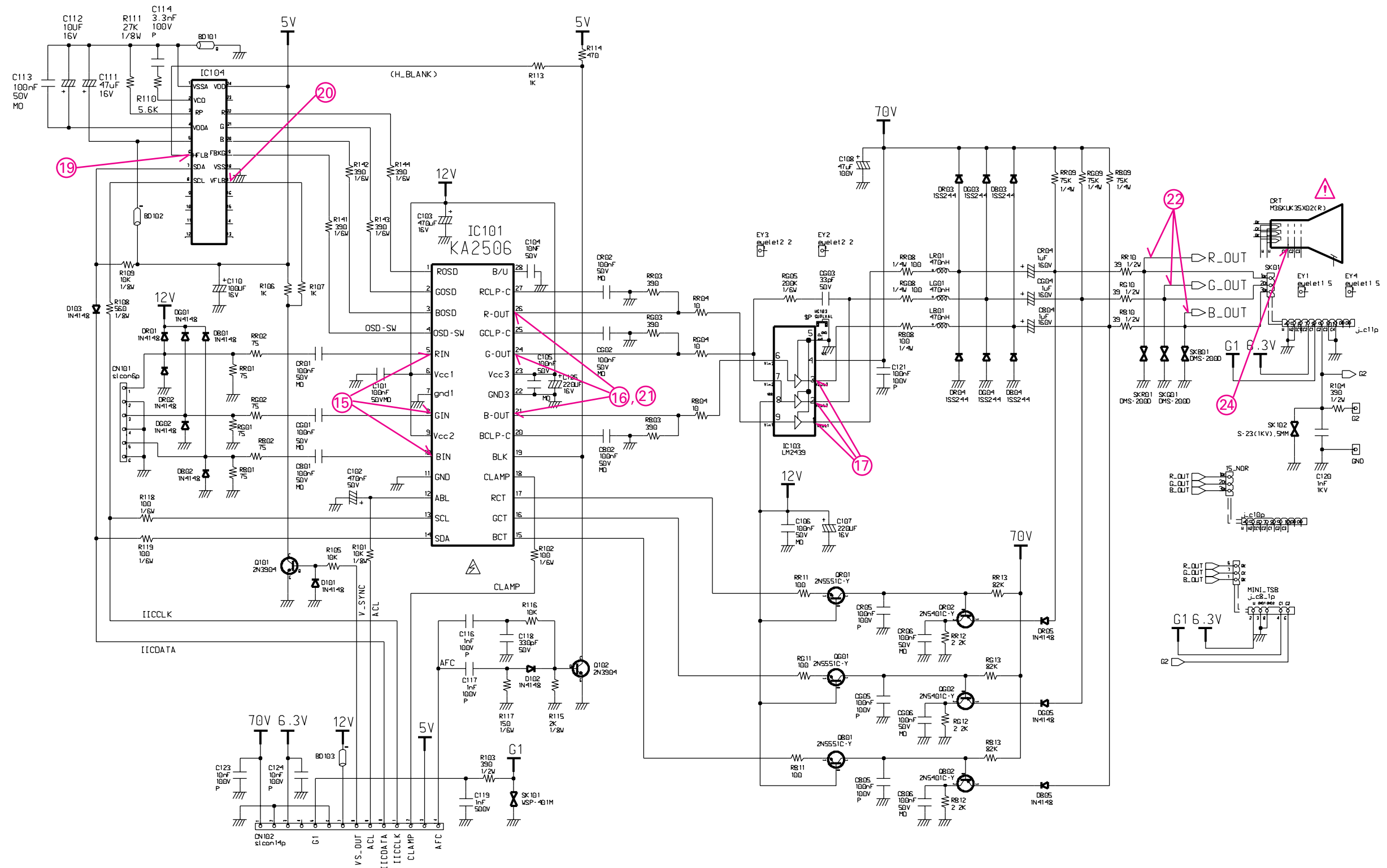

Table 10-8. IC101 (KA2506)

pin #	MODES		pin #	MODES	
	1024 x 768 / 85 Hz	640 x 480 / 60 Hz		1024 x 768 / 85 Hz	640 x 480 / 60 Hz
1	4.6 mV	3.2 mV	15	11.2 V	11.2 V
2	4.5 mV	3.2 mV	16	11.2 V	11.2 V
3	4.4 mV	3.0 mV	17	11.2 V	11.2 V
4	4.0 mV	2.8 mV	18	4.73 V	4.49 V
5	2.42 V	2.45 V	19	4.01 V	4.55 V
6	11.8 V	11.8 V	20	4.35 V	4.34 V
7	1.06 mV	1.0 mV	21	2.42	2.56 V
8	2.42 V	2.44 V	22	1.6 mV	1.5 mV
9	11.85 V	11.8 V	23	11.8 V	11.8 V
10	2.41 V	2.43 V	24	2.40	2.53 V
11	1.44 mV	1.39 mV	25	4.29	4.27 V
12	4.22 V	4.15 V	26	2.55	2.68 V
13	5.11 V	5.11 V	27	4.31	4.29 V
14	5.11 V	5.11 V	28	99.1 mV	99.5 mV

Unit: Vrms

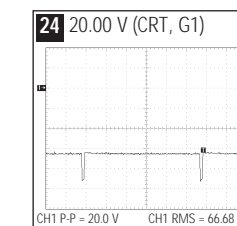
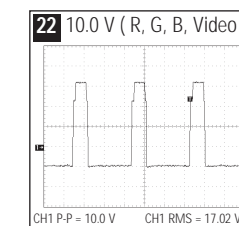
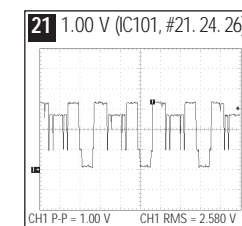
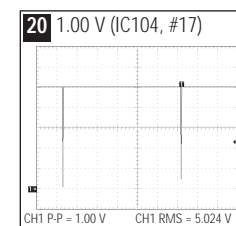
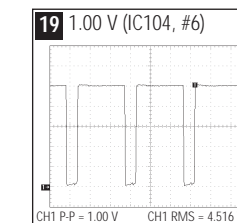
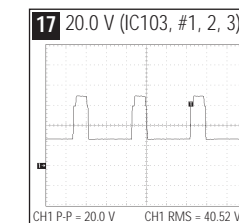
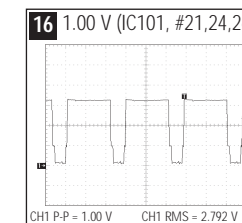
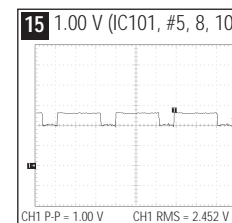

Table 10-9. IC103 (LM2437)

pin #	MODES	
	800 x 600 / 85 Hz	640 x 480 / 60 Hz
1	38.5	36.9
2	39.9	38.1
3	GND	GND
4	2.4 V	2.53
5	2.55	2.68
6	11.8	11.8
7	2.4 V	2.4 V
8	72.8	73.2
9	42.5	40.2

Unit: Vrms

Table 13-10. IC104 (KS2501 ~ 09)

pin #	MODES	
	1024 x 768 / 85 Hz	640 x 480 / 60 Hz
1	1.3 mV	NC
2	2.24 V	NC
3	1.26 V	NC
4	1.27 V	NC
5	4.93	4.91
6	3.99	1.9 mV
7	5.11	4.9
8	5.11	5.3 V
9	NC	5.5 V
10	NC	5.6 V
11	NC	NC
12	NC	4.93

Unit: Vrms

Memo