



PDP-TELEVISION

Chassis : D74A(P_Europe_42SD)_Audi
Model : PS42E7SX/XEC

SERVICE Manual

PDP-TELEVISION



PS-42E7S

FEATURES

- DTV Ready PDP TV
- Supreme Picture Quality
Supreme Convenience Quality
- RF, HDMI, PC(Analog),
2 Component, 2 Video, S-Video
- Slim line design
- Energy Saving



This Service Manual is a property of Samsung Electronics Co.,Ltd.
Any unauthorized use of Manual can be punished under applicable
International and/or domestic law.

© Samsung Electronics Co., Ltd. Apr. 2006
Printed in Korea
AA82-03734A

Table of Contents

Chapter 1 Precaution

■ 1-1 Safety Precautions	1-1
■ 1-2 Servicing Precautions	1-3
■ 1-3 Static Electricity Precautions	1-4
■ 1-4 Installation Precautions	1-5

Chapter 2 Product Specification

■ 2-1 Product Features	2-1
■ 2-2 Key Features	2-2
■ 2-3 Specifications Analysis	2-4
■ 2-4 Accessories	2-5

Chapter 3 Alignment & Adjustment

■ 3-1 Service Instruction	3-1
■ 3-2 How to Access Service Mode	3-2
■ 3-3 Factory Data	3-3
■ 3-4 Service Adjustment	3-8
■ 3-5 Software Upgrade	3-11
■ 3-6 Replacements & Calibration	3-12

Chapter 4 Exploded View & Part List

■ 4-1 PS42E7SX/XEC	4-1
--------------------------	-----

Chapter 5 Electrical Part List

■ 5-1 PS42E7SX/XEC Service Item	5-1
---------------------------------------	-----

Chapter 6 Troubleshooting

■ 6-1 First Checklist for Troubleshooting	6-1
■ 6-2 Checkpoints by Error Mode	6-2
■ 6-3 Troubleshooting Procedures by ASS'Y	6-13

Chapter 7 Block Diagram

■ 7-1 Overall Block Diagram	7-1
■ 7-2 Partial Block Diagram	7-3

Chapter 8 Wiring Diagram

■ 8-1 Overall Wiring	8-1
■ 8-2 Partial Wiring	8-2

Chapter 9 PCB Diagram

■ 9-1 Main Board	9-1
■ 9-2 Power & IR Board	9-4
■ 9-3 Function Board	9-4
■ 9-4 Side AV Board	9-4
■ 9-5 Main SMPS Board	9-5
■ 9-6 DC-DC SMPS Board	9-6
■ 9-7 PDP Module	9-7

Chapter 10 Schematic Diagram

■ 10-1 Analog	10-1
---------------	------

Chapter 11 Operation Instruction & Installation

■ 11-1 Product Features and Functions	11-1
■ 11-2 Installation Notes and Precautions	11-4

Chapter 12 Disassembly & Reassembly

■ 12-1 Overhaul Disassembly & Reassembly	12-1
--	------

Chapter 13 Circuit Description

■ 13-1 Power ON/OFF Signal Timing Sequence	13-1
■ 13-2 Partial Block Description	13-2

Chapter 14 Reference Information

■ 14-1 Other issues related to other products	14-1
■ 14-2 Technical Terms	14-3

7. Block Diagram

7-1 Overall Block Diagram

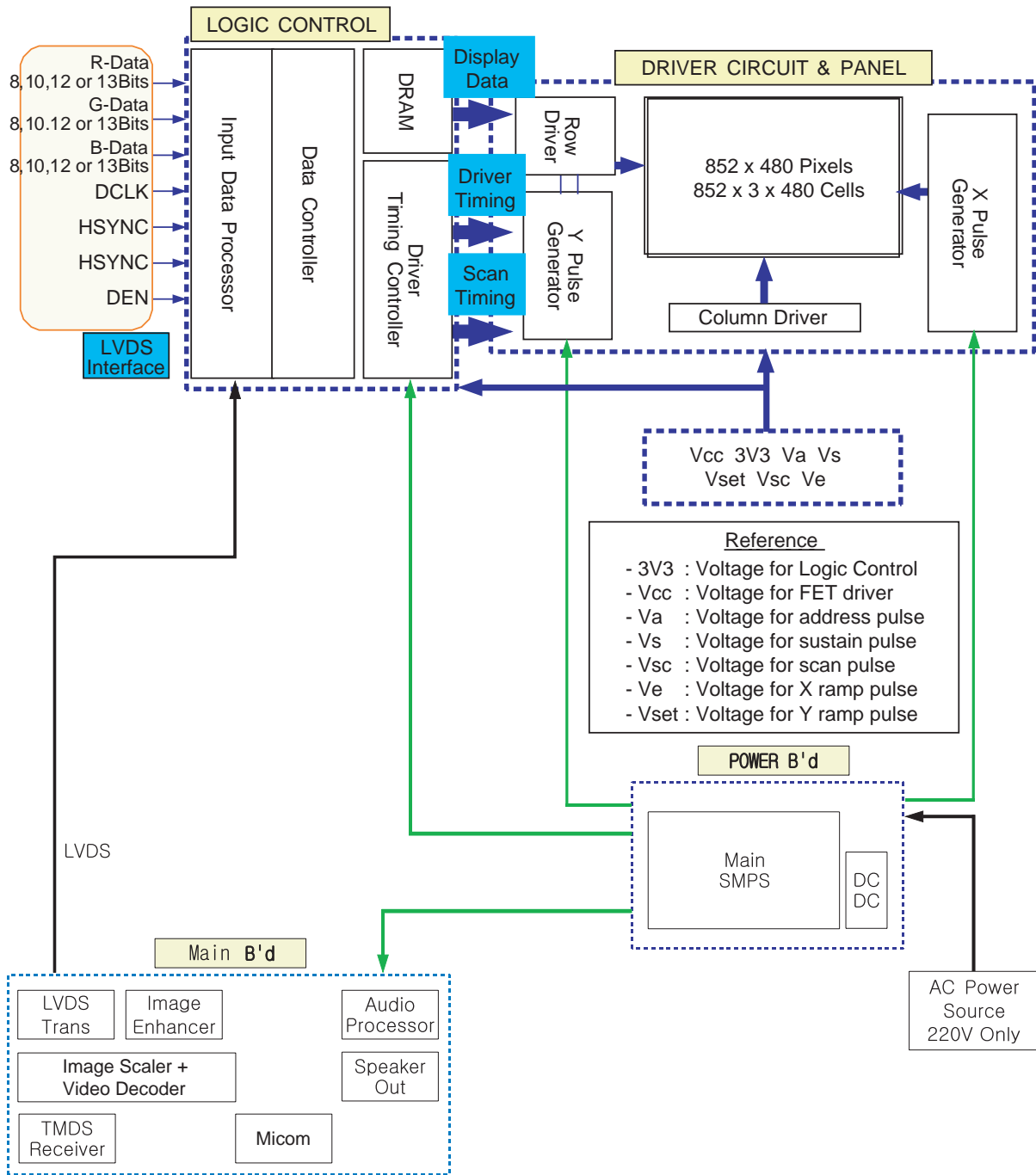

CN804-1(Main SMPS) ↔ CN102(Main Board)		CN803(Main SMPS) ↔ CN101(Main Board)		CN810(Main SMPS) ↔ CN2013(Logic Board)		CN2(DC-DC SMPS) ↔ CN5007(Y B'D)		CN4(DC-DC SMPS) ↔ CN4001(X B'D)	
Pin No.	Signal	Pin No.	Signal	Pin No.	Signal	Pin No.	Signal	Pin No.	Signal
1	5.3V	1	6.5V	1	STBY	1	Vs	1	D5.3V
2	RTN	2	RTN	2	VS_ON	2	Vs	2	Vg
3	N/C	3	12V	3	N/C	3	RTN	3	RTN
4	N/C	4	RTN	4	PS_ON	4	RTN	4	RTN
5	RTN	5	18Vamp	5	RTN	5	Vset	5	Ve
6	RTN	6	18Vamp	6	5.3V	6	RTN	6	RTN
7	12V	7	RTN_amp	7	RTN	7	Vscan	7	RTN
8	PS_ON	8	RTN_amp	8	RTN	8	RTN	8	Vs
9	RTN	9	Vt	9	5.3V	9	Vg	9	Vs
10	STBY	10	RTN	10	5.3V	10	D5.3V		
11	FAN_ON								
12	FAN_D								

CN6(DC-DC SMPS) ↔ CN2509(E-Buffer)	
Pin No.	Signal
1	RTN
2	N.C
3	D5.3V
4	N/C
5	Va

7-2 Partial Block Diagram

7-2-1 Audio/Video Signal Block Diagram

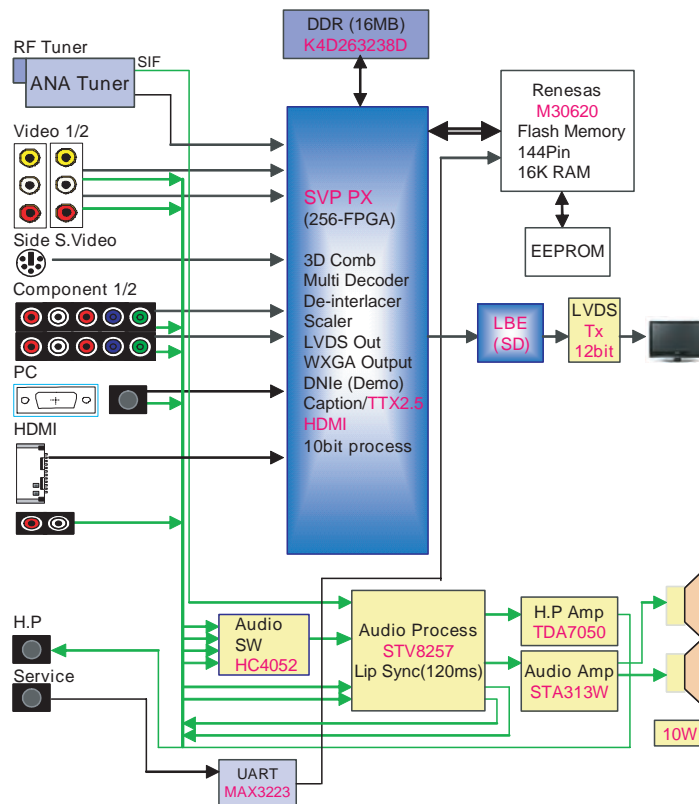

7-2-2 DC-DC SMPS Block Diagram

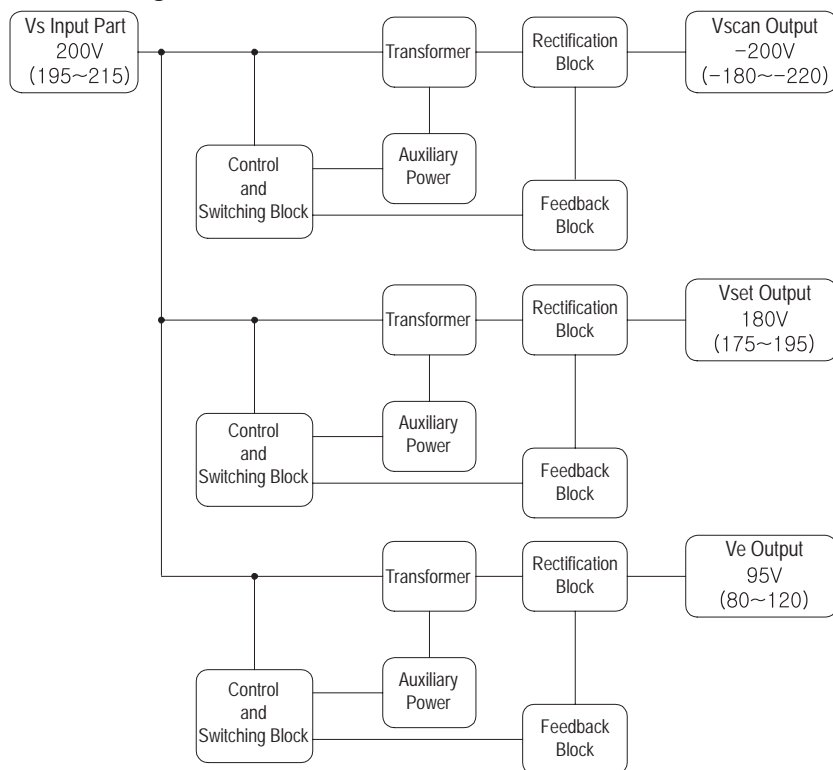

7-2-3 Module Driver Board Block Diagram

1. Y Drive Board

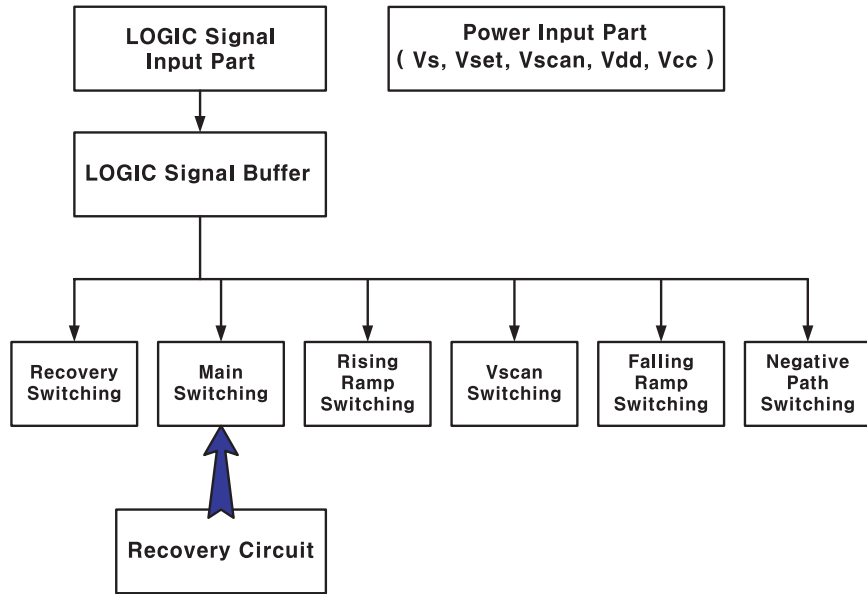

2. X Drive Board

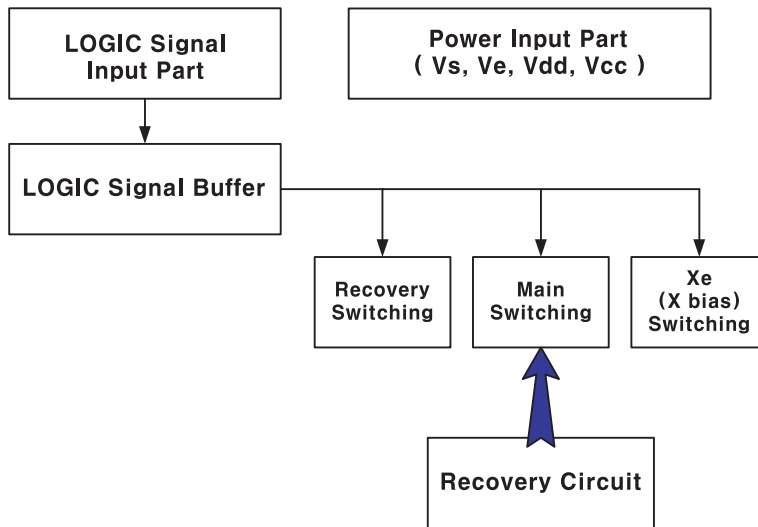

7-2-4 Logic Board Block Diagram

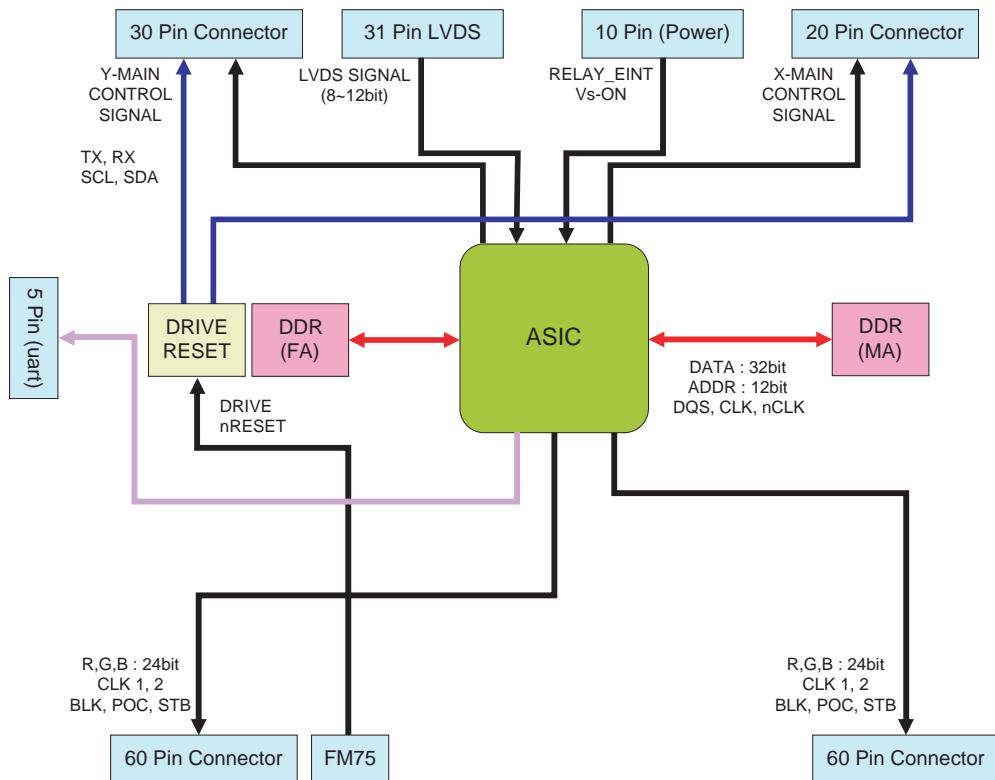

7-2-5 Power Block Diagram

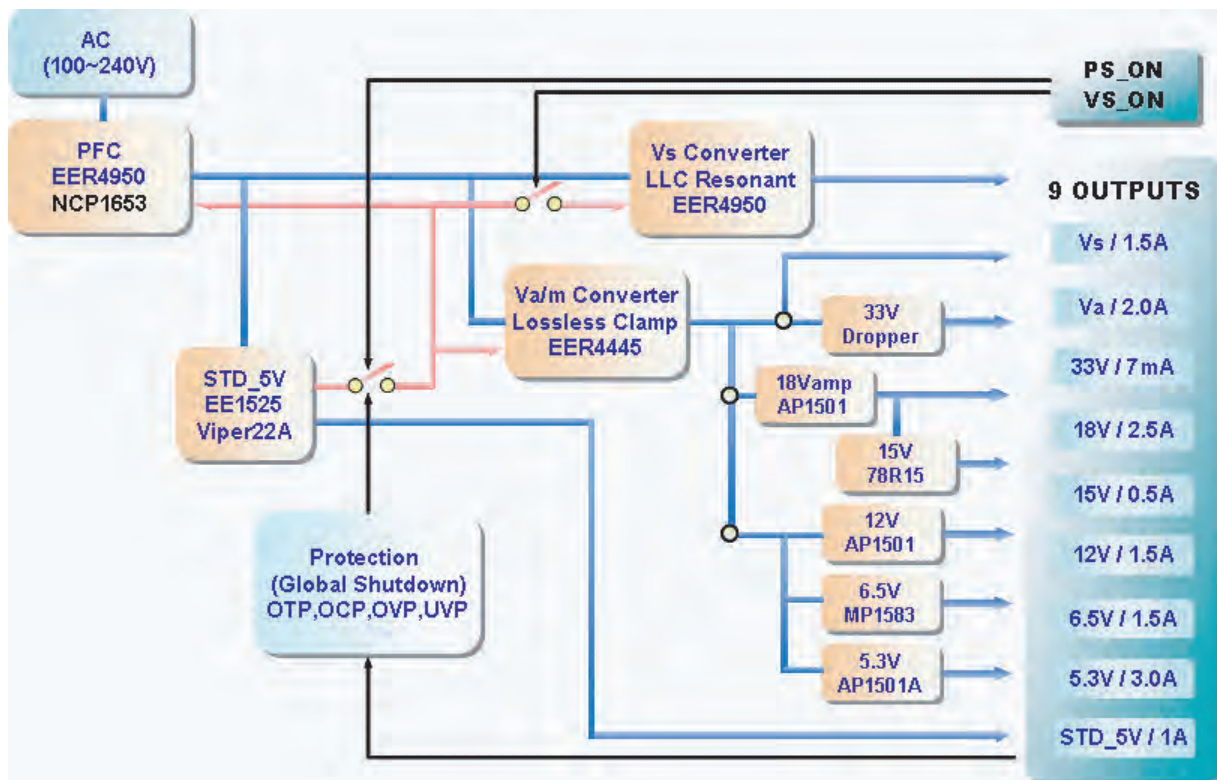

MEMO

8. Wiring Diagram

8-1 Overall Wiring

※ The ASSY code can be changed, see "5 Chapter. Electrical Part List."

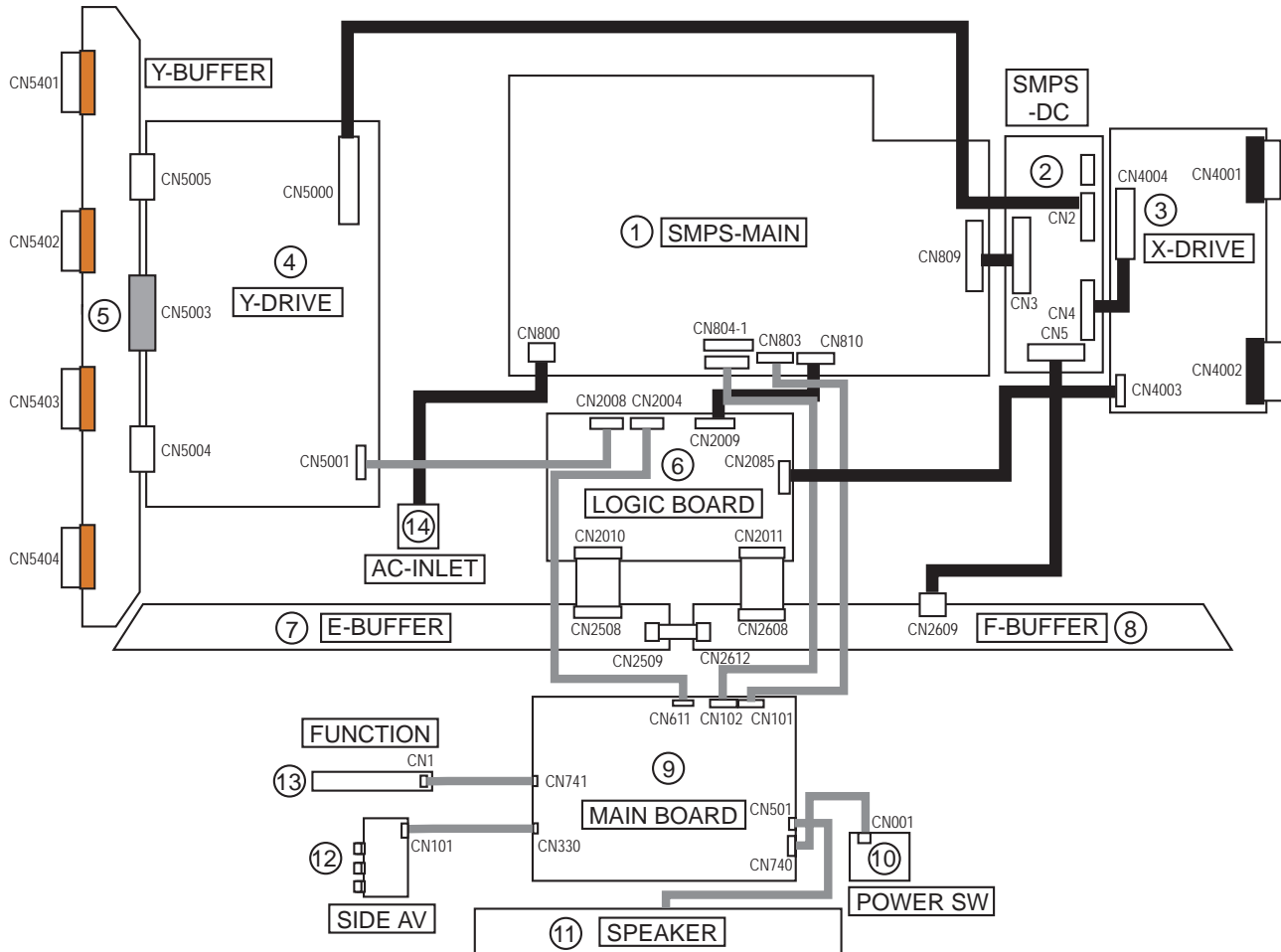

No	Assy	Code No.	Description
-	ASSY PDP MODULE P	BN96-03073A	M1,SPD-42D5SD,D71C,V5.0,1000?588,852?480,NTSC/PAL,42"SD
①	ASSY PCB P-SMPS	BN96-03052A	PS42E7H,100-240V,245*370mm
②	ASSY PCB P-SMPS	BN96-01856A	SPD-50P5HD(DC_DC),200Vin(DC_DC)
③	ASSY PDP MODULE P-X MAIN BOARD	BN96-03101A	M1,PL42SD011A,V5.0,852*480,NTSC/PAL,42",SD,LJ92-01340A
④	ASSY PDP MODULE P-Y MAIN BOARD	BN96-03102A	M1,PL42SD011A,Y-Main board,V5.0,852*480,NTSC/PAL,42",SD
⑤	ASSY PDP MODULE P-Y MAIN SCAN BUFFER	BN96-03103A	M1,PL42SD011A,Y-scan buffer,V5.0,852*480,NTSC/PAL,42",SD
⑥	ASSY PDP MODULE P-LOGIC MAIN BOARD	BN96-03106A	M1,PL42SD011A,logic main,V5.0,852*480,NTSC/PAL,42",SD
⑦	ASSY PDP P-ADDRESS E BUFFER	BN96-03104A	M1,PL42SD011A,address e-buffer,V5.0,852*480,NTSC/PAL,42",SD
⑧	ASSY PDP P-ADDRESS F BUFFER	BN96-03105A	M1,PL42SD011A,address f-buffer,V5.0,852*480,NTSC/PAL,42",SD
⑨	ASSY PCB MISC-MAIN	BN94-00933B	PS-42E7S,EU,D74A,AUDI
⑩	ASSY BOARD P-POWER&IR	BN96-02050D	Twister,CT5000-3530A,POWER & IR,Core,No LED Holder
⑪	ASSY SPEAKER P	BN96-02785A	8ohm,Twister,42inch,10W
⑫	ASSY BOARD P-SIDE AV	BN96-03075A	AUDI,SJ05-01-430,Side A/V,42E7, With Bracket Shield
⑬	ASSY BOARD P-FUNCTION	BN96-02784A	TWISTER,CT5000-3850A,FUNCTION,42V6,With Knob
⑭	FILTER-EMI AC LINE	2901-001374	250V,6A,UL/SA/VDE,0.15uF/1000pF,50x22.5x37.2mm,BK,AE

8-2 Partial Wiring



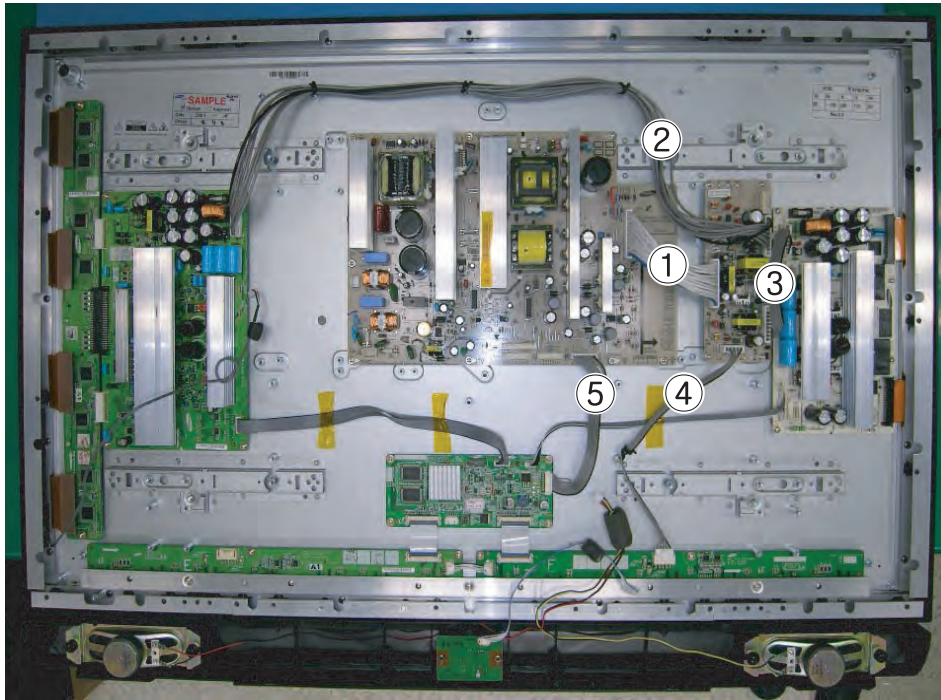

8-2-1 PDP Module ↔ SMPS Wiring

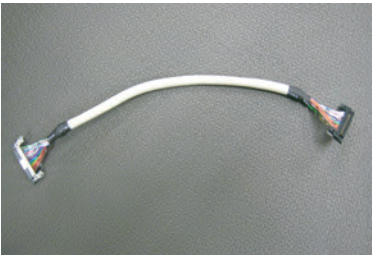

① CN809(Main SMPS) ↔ CN3(DC-DC SMPS)		② CN2(DC-DC SMPS) ↔ CN5007(Y B'D)		③ CN4(DC-DC SMPS) ↔ CN4001(X B'D)		④ CN6(DC-DC SMPS) ↔ CN2509(E-Buffer)		⑤ CN810(Main SMPS) ↔ CN2013(Logic B'D)	
Pin No.	Signal	Pin No.	Signal	Pin No.	Signal	Pin No.	Signal	Pin No.	Signal
1	D5.3V	1	Vs	1	D5.3V	1	RTN	1	STD_5V
2	Vg	2	Vs	2	Vg	2	N.C	2	VS_ON
3	RTN	3	RTN	3	RTN	3	D5.3V	3	N/C
4	RTN	4	RTN	4	RTN	4	N/C	4	PS_ON
5	RTN	5	Vset	5	Ve	5	Va	5	RTN
6	RTN	6	RTN	6	RTN			6	D5.3V
7	RTN	7	Vscan	7	RTN			7	RTN
8	Va	8	RTN	8	Vs			8	RTN
9	Va	9	Vg	9	Vs			9	D5.3V
10	N/C	10	D5.3V					10	D5.3V
11	Vs								
12	Vs								

8-2-2 Connect Cables

※ The code number of cable(Lead-connector) can be changed, see "5 Chapter. Electrical Part List."

Use	SMPS 12P	LVDS 31P	POWER 10P
Code	BN39-00632B	BN39-00667D	BN39-00675A
Photo			
Use	POWER 12P	EMI ONEPOINT WIRE	
Code	BN39-00676A	BN39-00164E	
Photo			

MEMO

9. PCB Diagram

9-1 Main Board

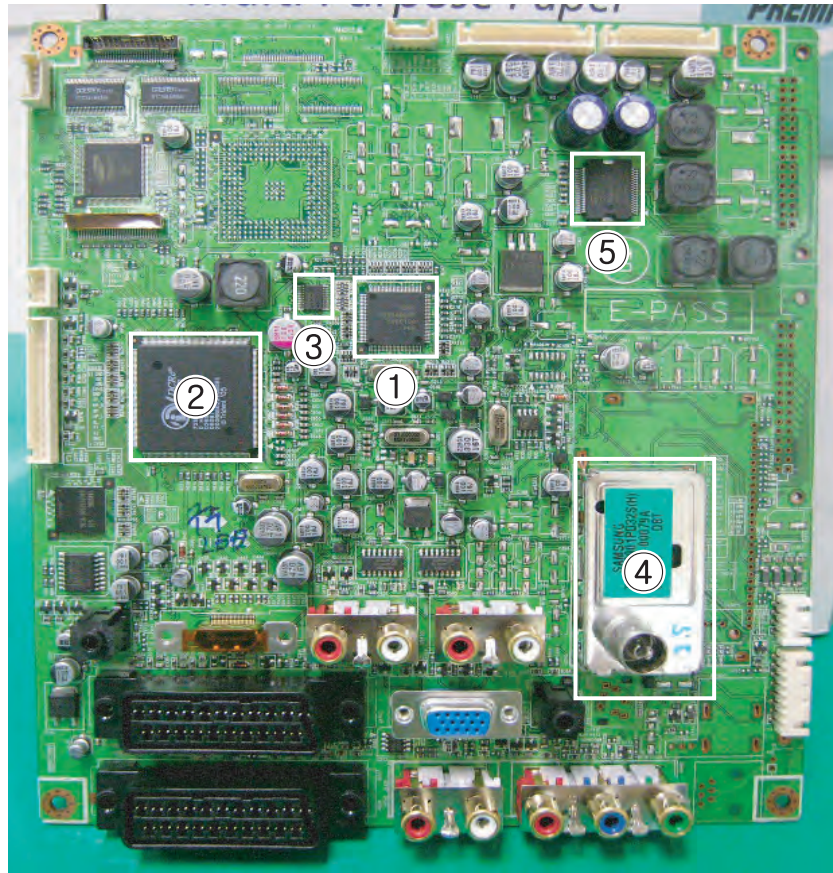

No	Name	Function	Description
①	SVP-PX	Scaler IC Controller	SVPTMPX contains dual-purposed triple 10-bit high-precision and high speed video ADCs for both PC and video inputs, the high speed HDMI could support all HDMI inputs up to 135MHz with HDCP format, the highperformance multi-format 3D digital comb video decoder that supports NTSC, PAL, and SECAM*, a HDTV sync separator, motion adaptive de-interlacing engine, and the video format conversion engine, supporting multi-window display in many different output modes.
②	M30840SGP	IC MICOM	With a 16-Mbyte address space, this microcomputer combines advanced instruction manipulation capabilities to process complex instructions by less bytes and execute instructions at higher speed.
③	FBE	IC DNle	Image enhancement IC
④	TCPS3001PD32S(H)	TUNER	Tuner CH Tuning
⑤	STA323W	IC AUDIO-AMP	Audio power amplifiers

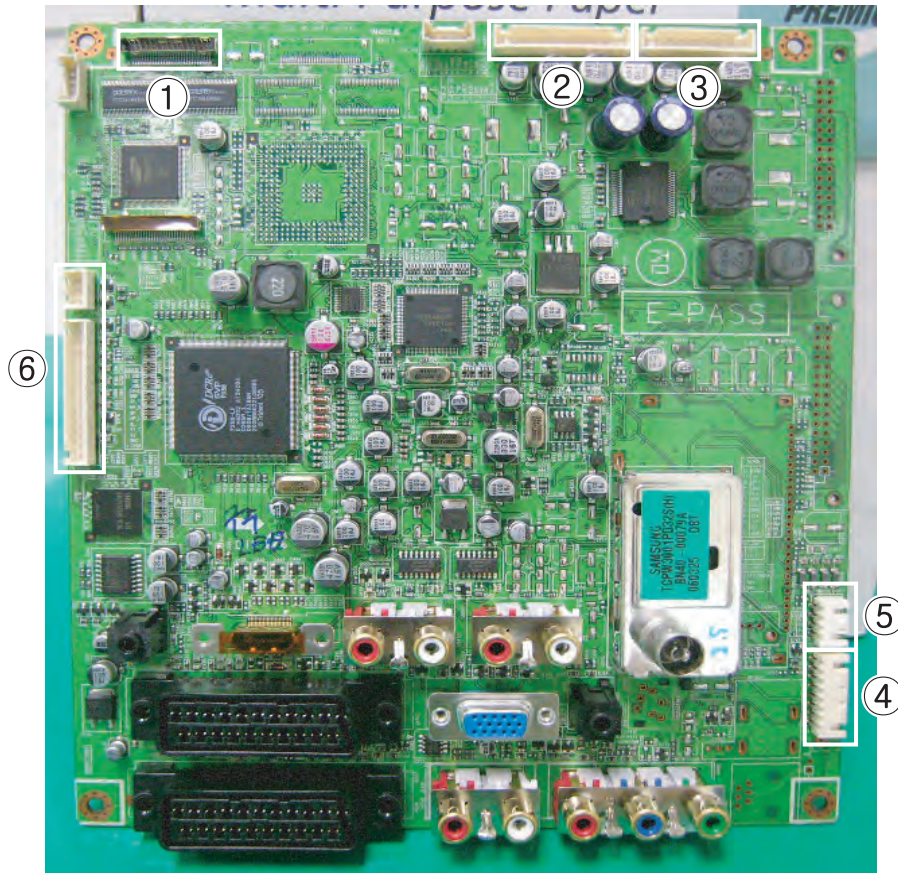

① CN2013(Logic B'D) ↔ CN902(Main Board)					
Pin No.	Signal	Pin No.	Signal	Pin No.	Signal
1	GND	12	TXOUT2+	23	TXOUT0B-
2	GND	13	GND	24	TXOUT0B+
3	TXOUT-	14	GND	25	
4	TXOUT+	15	TXOUTCLK-	26	GND
5	GND	16	TXCLKOUT+	27	SCL_G
6	GND	17		28	GND
7	TXOUT-	18		29	SDA_G
8	TXOUT+	19	TXOUT3-	30	GND
9		20	TXOUT3+	31	
10		21		32	GND
11	TXOUT2-	22		33	GND

② CN804-1(Main SMPS) ↔ CN102(Main Board)	
Pin No.	Signal
1	5.3V
2	RTN
3	N/C
4	N/C
5	RTN
6	RTN
7	12V
8	PS_ON
9	RTN
10	STBY
11	FAN_ON
12	FAN_D

③ CN803(Main SMPS) ↔ CN108(Main Board)	
Pin No.	Signal
1	6.5V
2	RTN
3	12V
4	RTN
5	18Vamp
6	18Vamp
7	RTN_amp
8	RTN_amp
9	Vt
10	RTN

④ CN740(Main Board) ↔ CN001(Power Button)		⑤ CN501(Main Board) ↔ Speaker Out		⑥ CN741(Main Board) ↔ CN1(Function Board)	
Pin No.	Signal	Pin No.	Signal	Pin No.	Signal
1	GND	1	SPK_R+	1	KEY_INPUT1
2	LED	2	SPK_R-	2	KEY_INPUT2
3	ST5V	3	SPK_L+	3	GND
4	GND	4	SPK_L-		
5	KEY_INPUT2				
6					
7					
8	IR_7414				

9-2 Power & IR Board

No	Loc. No.	Description
①	RM1	Remote Control Sensor
②	SW1	Power Button
③	OP1	The Illumination sensor that senses the quantity of light. It senses the illumination and automatically adjusts the screen brightness according to the surrounding brightness when the Power Saving Mode of the User menu is set to Auto.

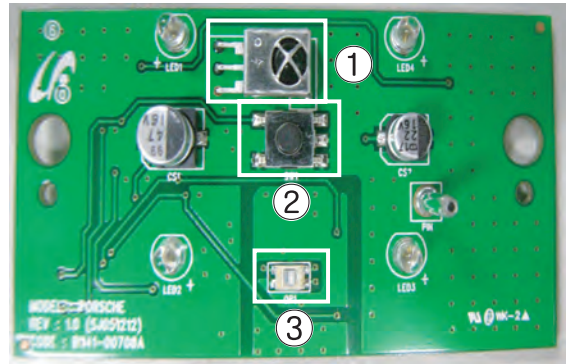

9-3 Function Board

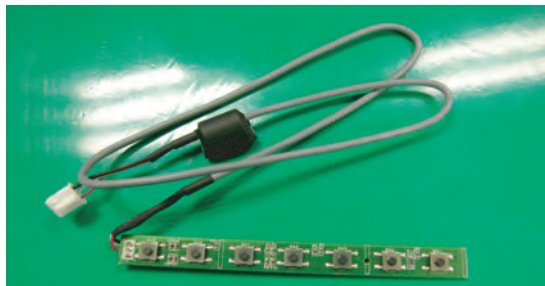

Function Key. Located on the side of the unit.

9-4 Side AV Board

No	Loc. No.	Description
①	CN102	S-VIDEO2 Input Jack
②	CN103	AV2 Input Jack
③	CN104	Earphone Jack
④	CN105	Side AV Connector

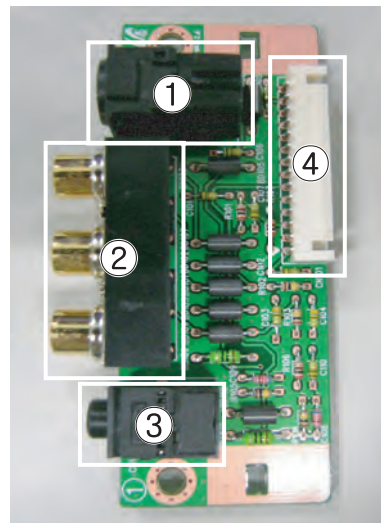

9-5 Main SMPS Board

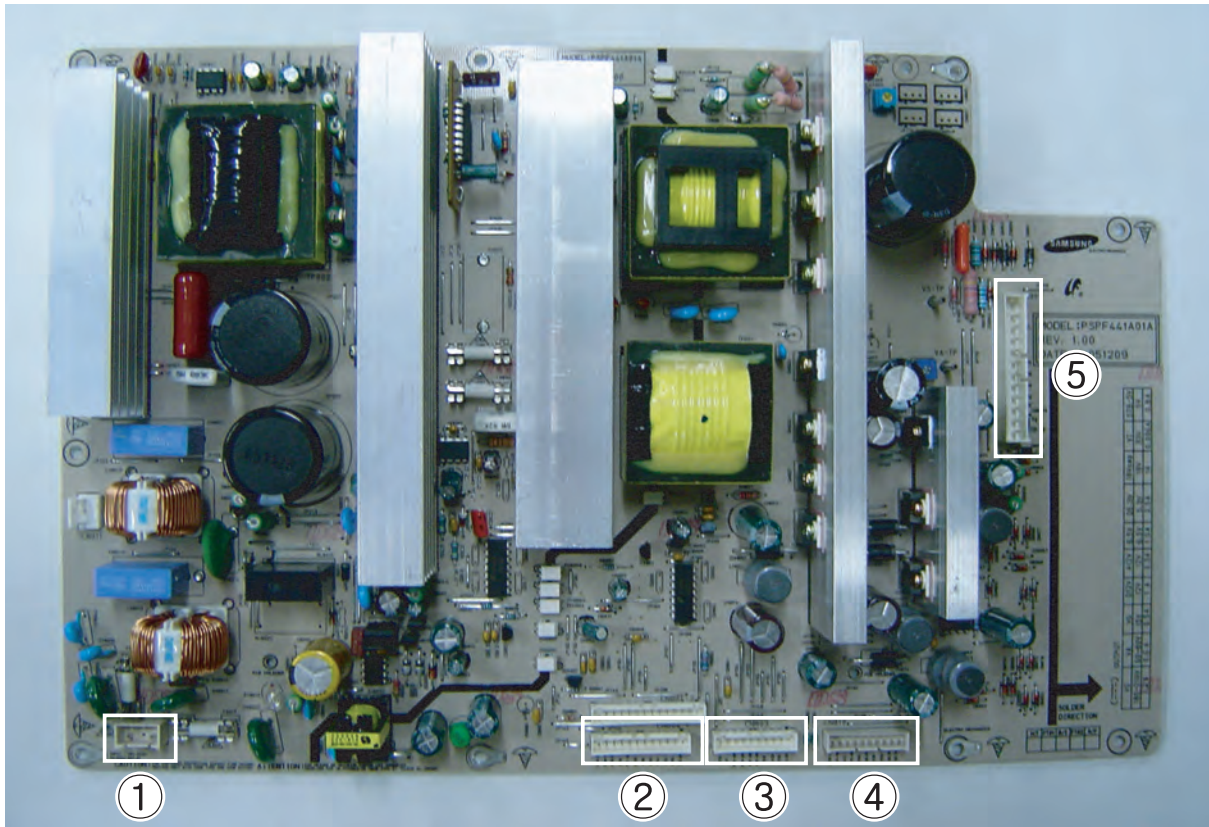

① CN800 : AC IN (90 ~ 264V)

② CN804-1(Main SMPS) ↔ CN102(Main Board)		③ CN803(Main SMPS) ↔ CN101(Main Board)		④ CN810(Main SMPS) ↔ CN2013(Logic Board)		⑤ CN809(Main SMPS) ↔ CN3(DC-DC SMPS)	
Pin No.	Signal	Pin No.	Signal	Pin No.	Signal	Pin No.	Signal
1	5.3V	1	6.5V	1	STBY	1	5.3V
2	RTN	2	RTN	2	VS_ON	2	Vg
3	N/C	3	12V	3	N/C	3	RTN
4	N/C	4	RTN	4	PS_ON	4	RTN
5	RTN	5	18Vamp	5	RTN	5	RTN
6	RTN	6	18Vamp	6	5.3V	6	RTN
7	12V	7	RTN_amp	7	RTN	7	RTN
8	PS_ON	8	RTN_amp	8	RTN	8	Va
9	RTN	9	Vt	9	5.3V	9	Va
10	STBY	10	RTN	10	5.3V	10	N/C
11	FAN_ON					11	Vs
12	FAN_D					12	Vs

※ CN811, CN804-2 and CN805, CN806, CN807, CN808 are not used.

9-6 DC-DC SMPS Board

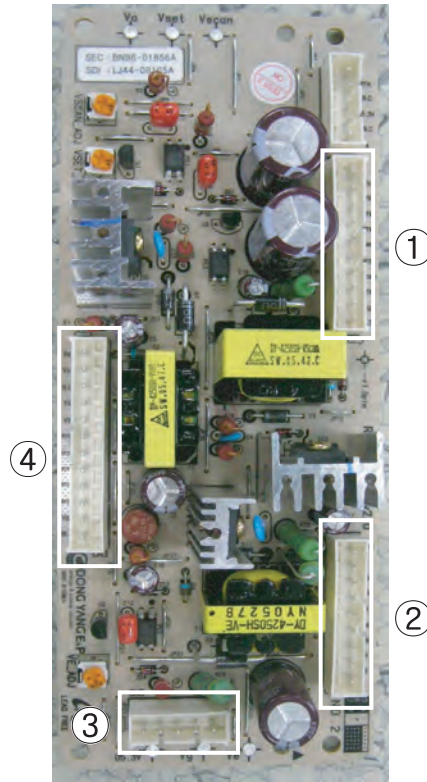

① CN2(DC-DC SMPS) ↔ CN5010(Y B'D)		② CN4(DC-DC SMPS) ↔ CN4004(X B'D)		③ CN5(DC-DC SMPS) ↔ CN2710(F-Buffer)		④ CN3(DC-DC SMPS) ↔ CN809(Main SMPS)	
Pin No.	Signal	Pin No.	Signal	Pin No.	Signal	Pin No.	Signal
1	Vs	1	Vs	1	RTN	1	D5.3V
2	Vs	2	Vs	2	N.C	2	Vg
3	RTN	3	RTN	3	D5.3V	3	RTN
4	RTN	4	RTN	4	N.C	4	RTN
5	Vset	5	Ve	5	Va	5	RTN
6	RTN	6	RTN			6	RTN
7	Vscan	7	RTN			7	RTN
8	RTN	8	Vg			8	Va
9	Vg	9	D5.3V			9	Va
10	D5.3V					10	N.C
						11	Vs
						12	Vs

9-7 PDP Module

※ The ASS'Y code can be changed, see "5 Chapter. Electrical Part List."

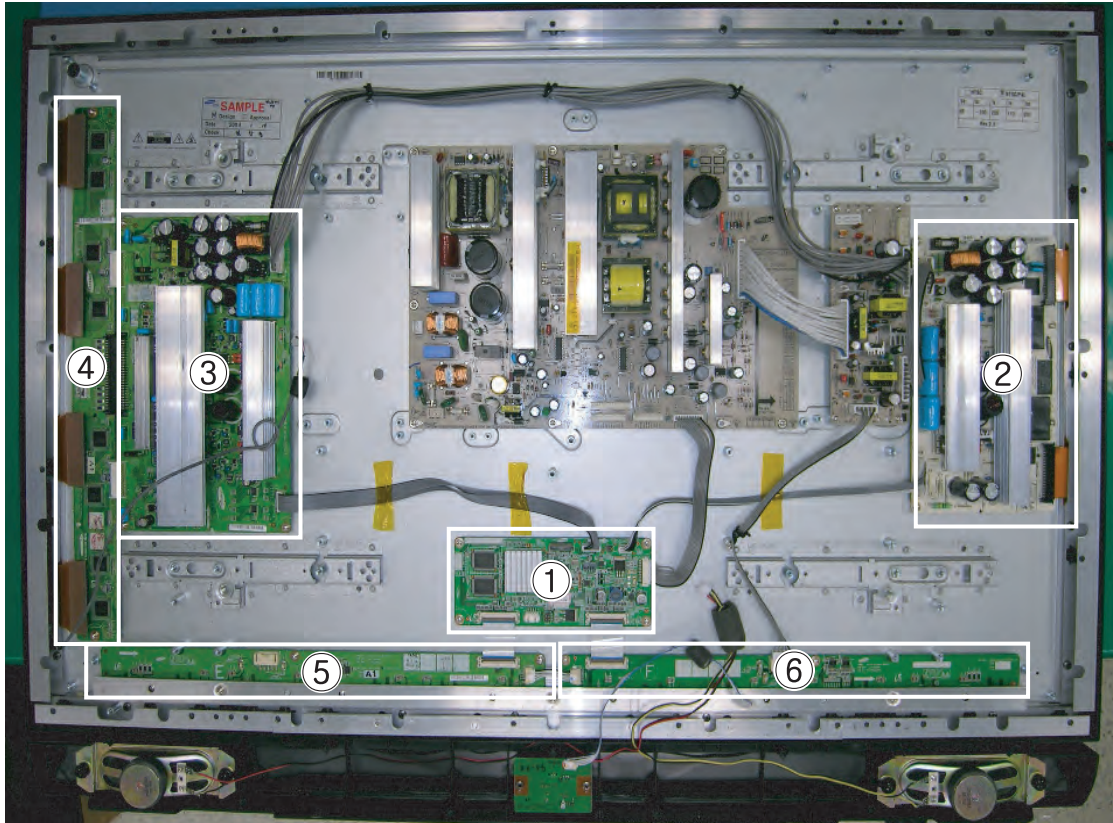

No	Assy	Code No.	Description
①	ASSY PDP MODULE P-LOGIC MAIN BOARD	BN96-03106A	Logic Main Board
②	ASSY PDP MODULE P-X MAIN BOARD	BN96-03101A	X Drive Board
③	ASSY PDP MODULE P-Y MAIN BOARD	BN96-03102A	Y Drive Board
④	ASSY PDP MODULE P-Y MAIN SCAN BUFFER	BN96-03103A	Y Buffer Board
⑤	ASSY PDP MODULE P-ADDRESS E BUFFER	BN96-03104A	Address Buffer Board
⑥	ASSY PDP MODULE P-ADDRESS F BUFFER	BN96-03105A	Address Buffer Board



MEMO

10. Schematic Diagram

10-1 Analog

10-1-1 POWER

This Document can not be used without Samsung's authorization.

	Power
	Signal

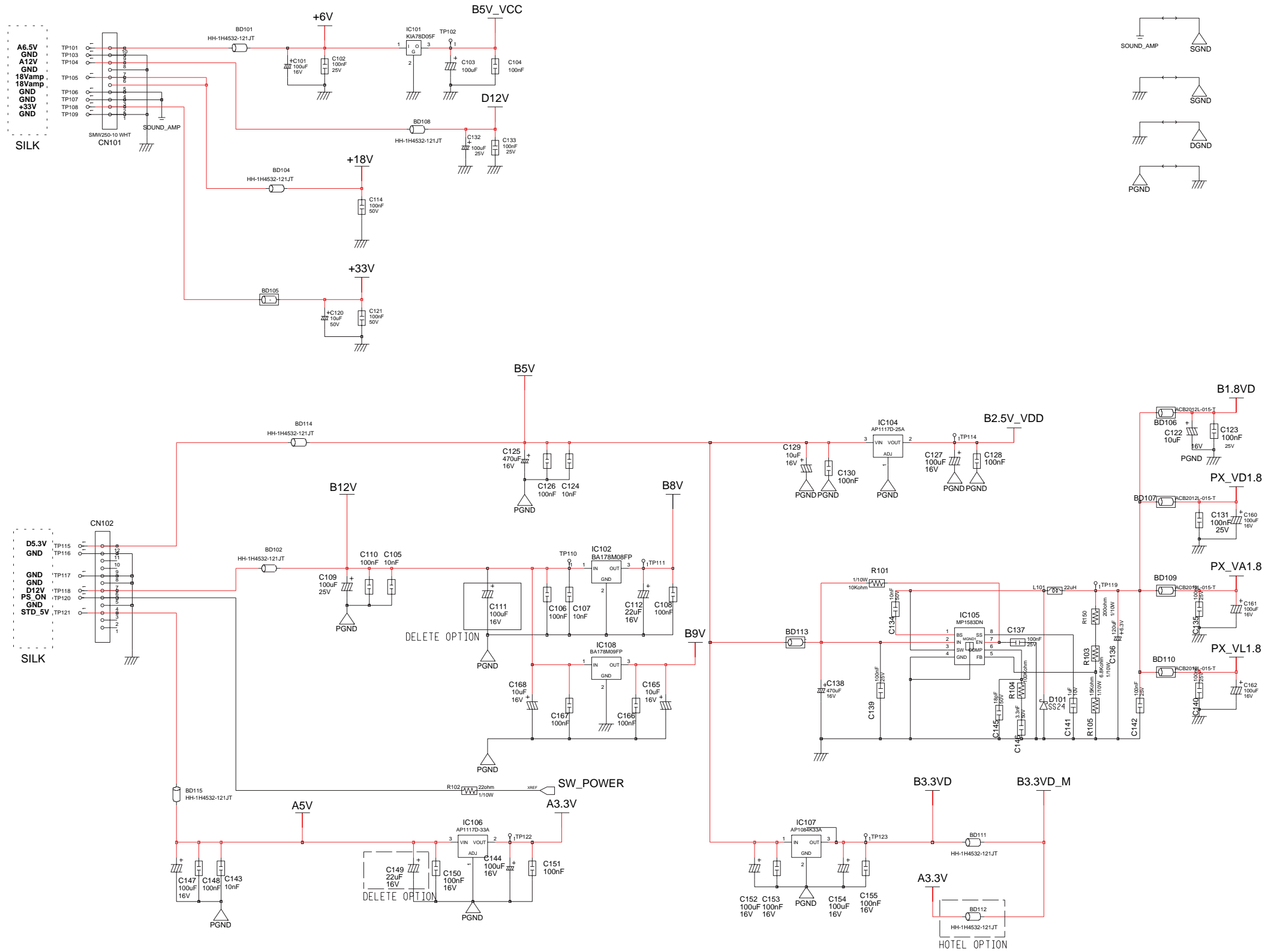

10-1-2 MICOM

This Document can not be used without Samsung's authorization.



MICOM

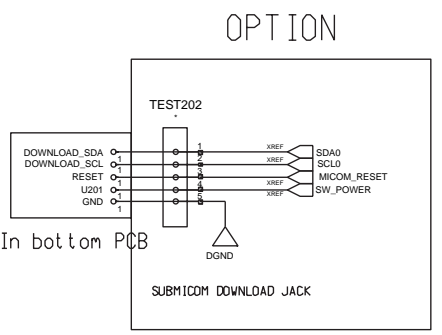
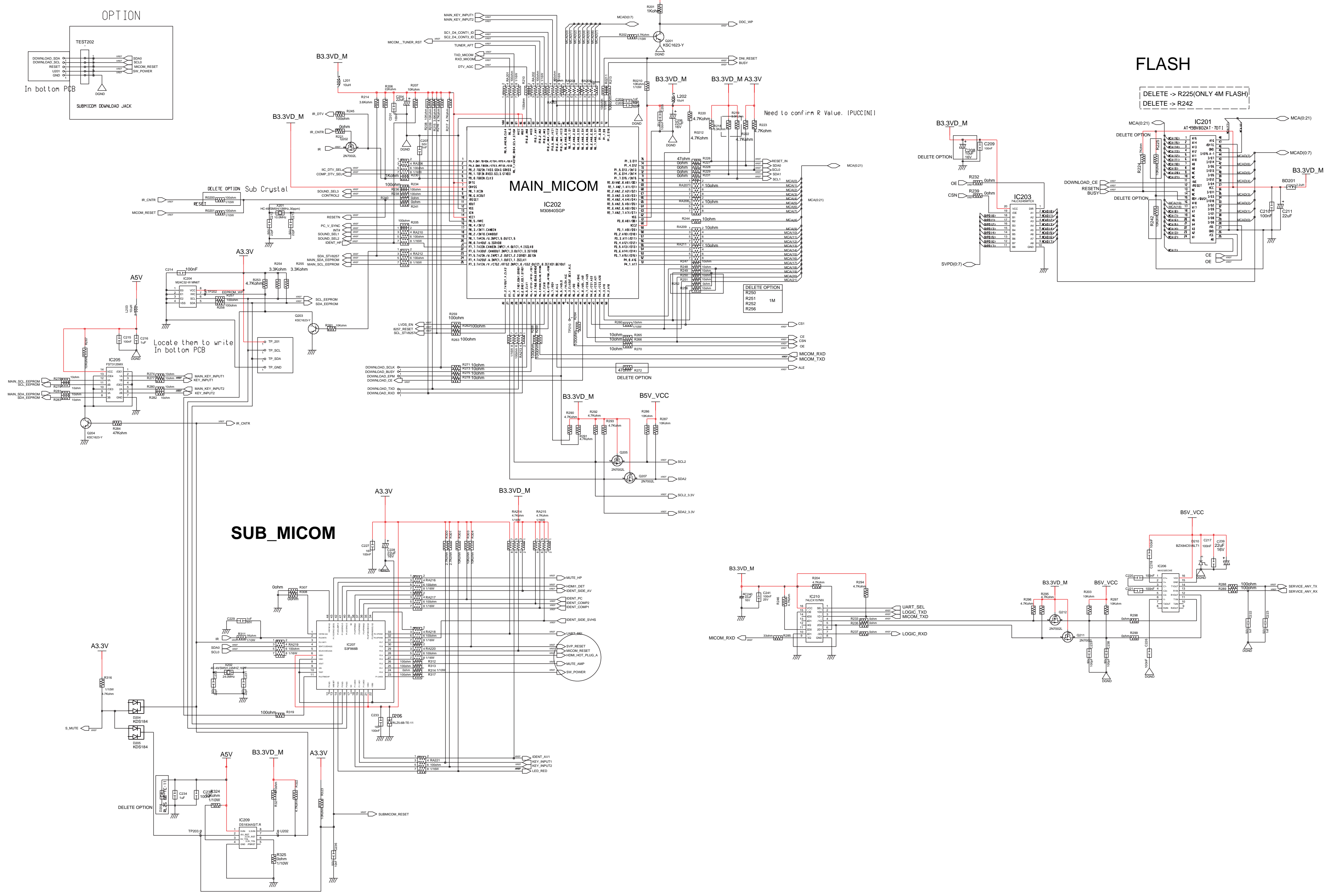

FLASH

DELETE -> R225(ONLY 4M FLASH)
DELETE -> R242

SUB_MICOM

Locate them to write
in bottom PCB

Need to confirm R Value. (PUCCINI)

10-1-3 IN_OUT JACK

This Document can not be used without Samsung's authorization.

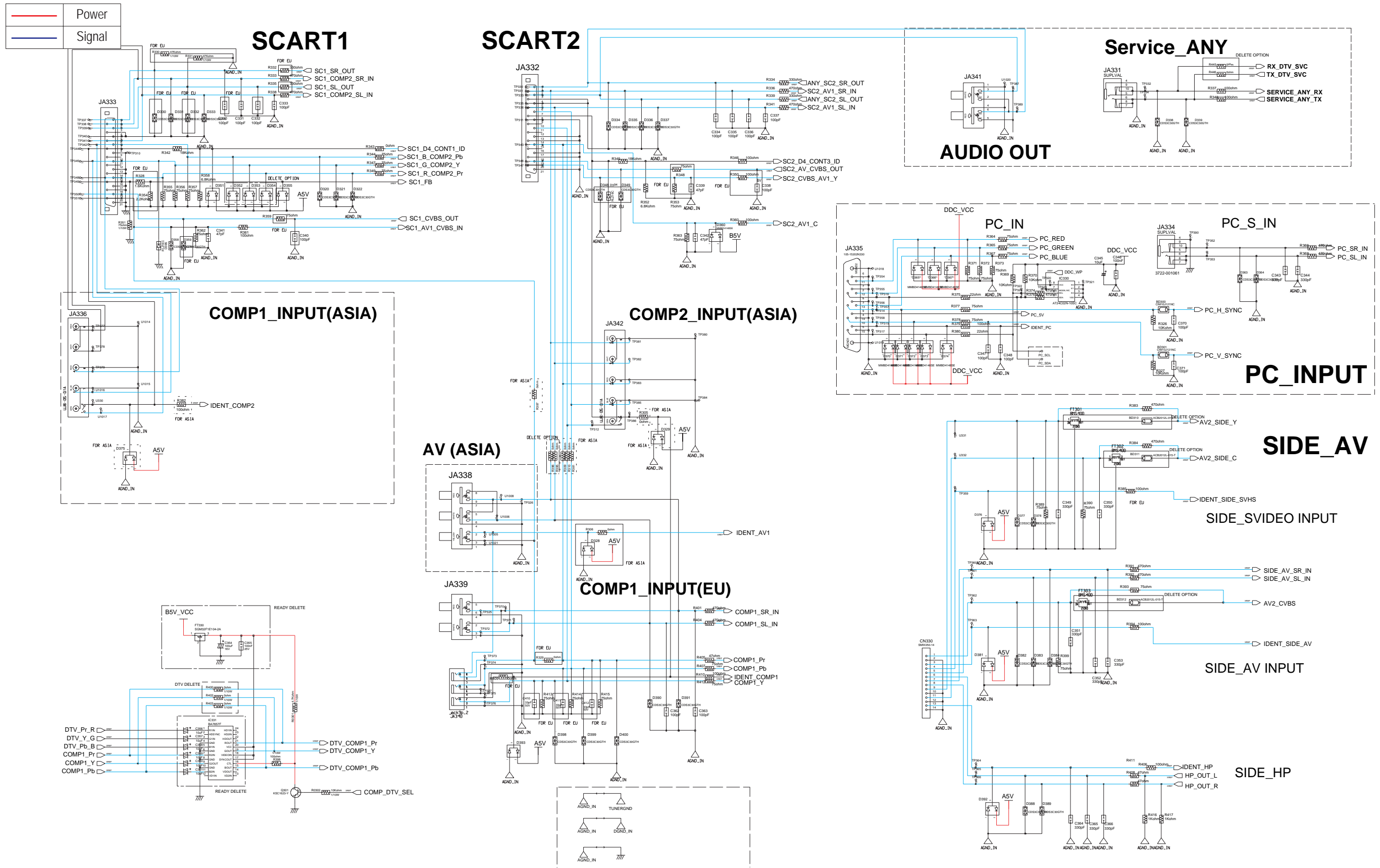

10-1-4 HDMI

This Document can not be used without Samsung's authorization.

	Power
	Signal

HDMI_INPUT

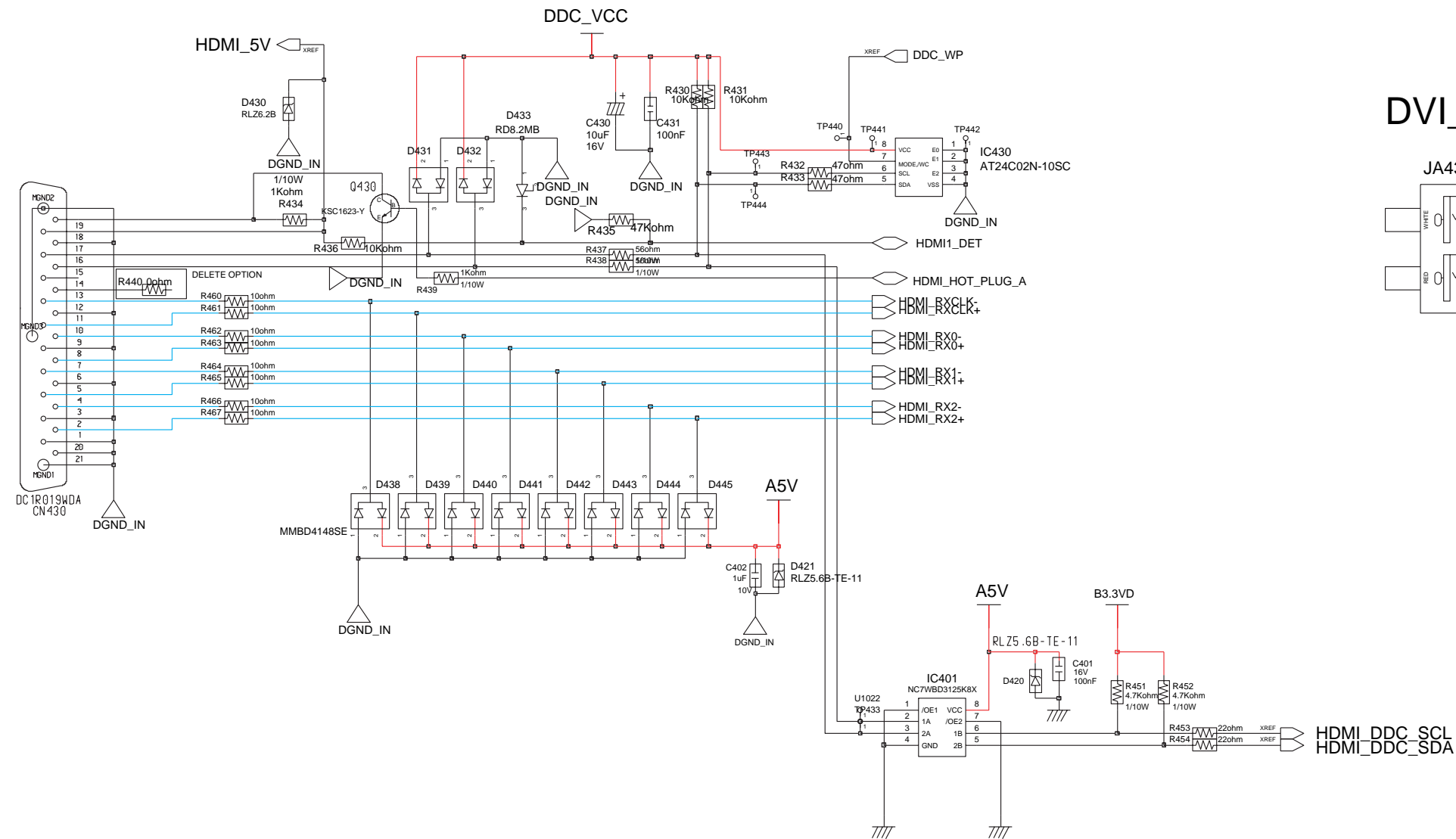

DVI_S_IN

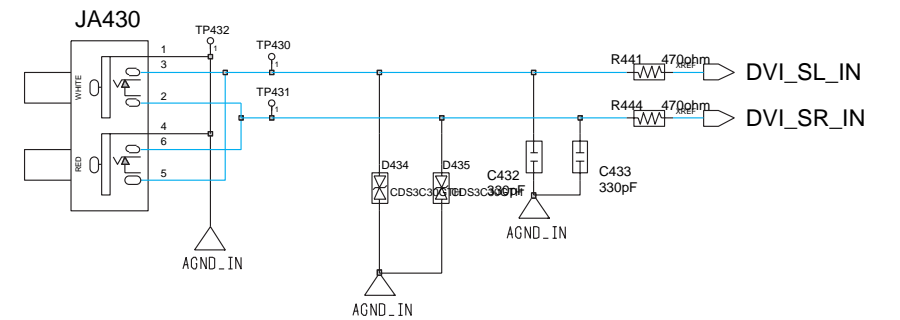

10-1-5 SOUND

This Document can not be used without Samsung's authorization.

	Power
	Signal

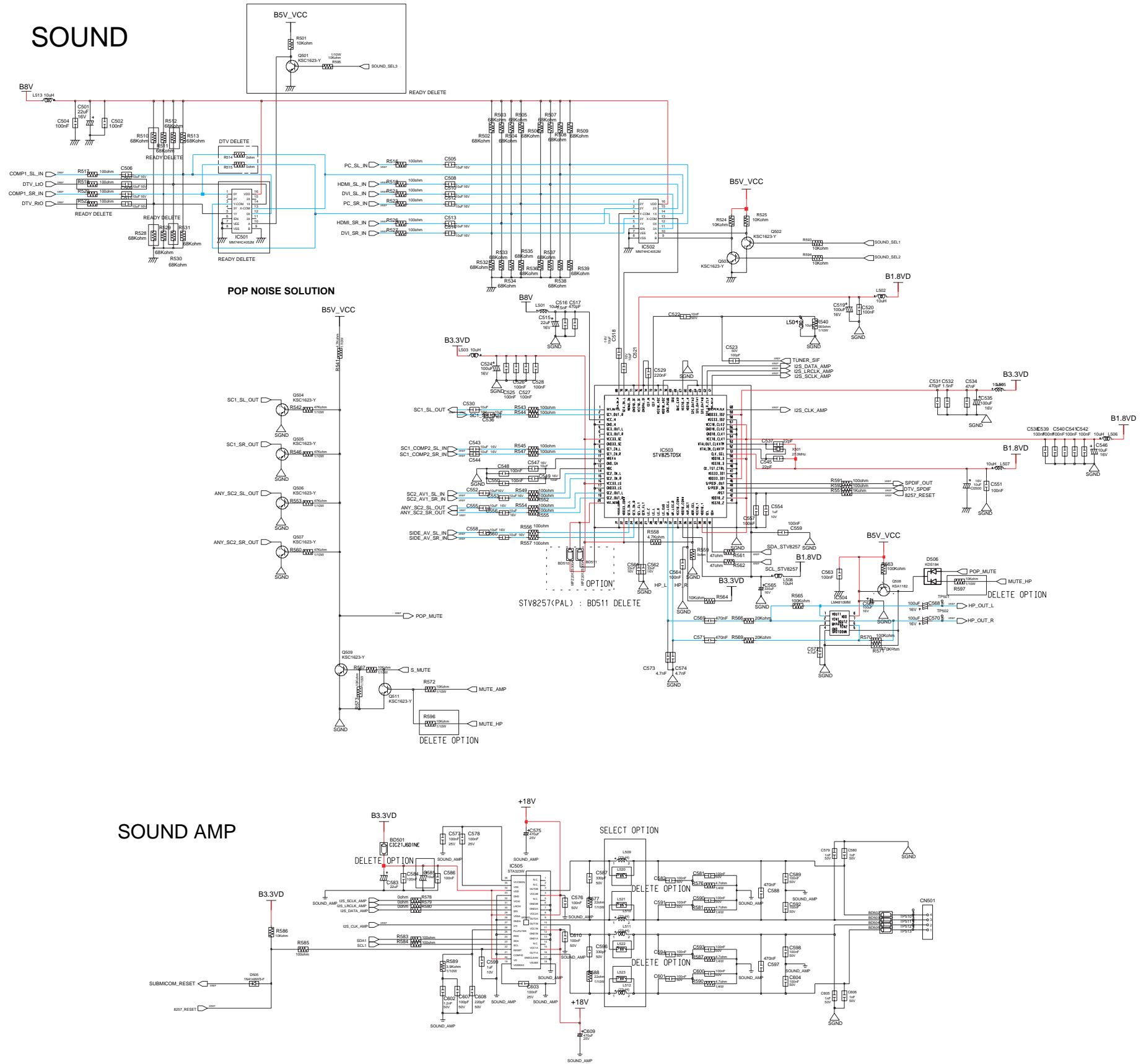

10-1-6 SVP-PX

This Document can not be used without Samsung's authorization.

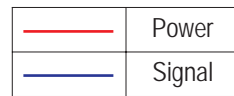

SVP-PX

E228322557

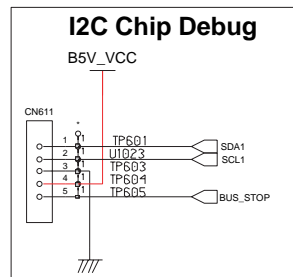
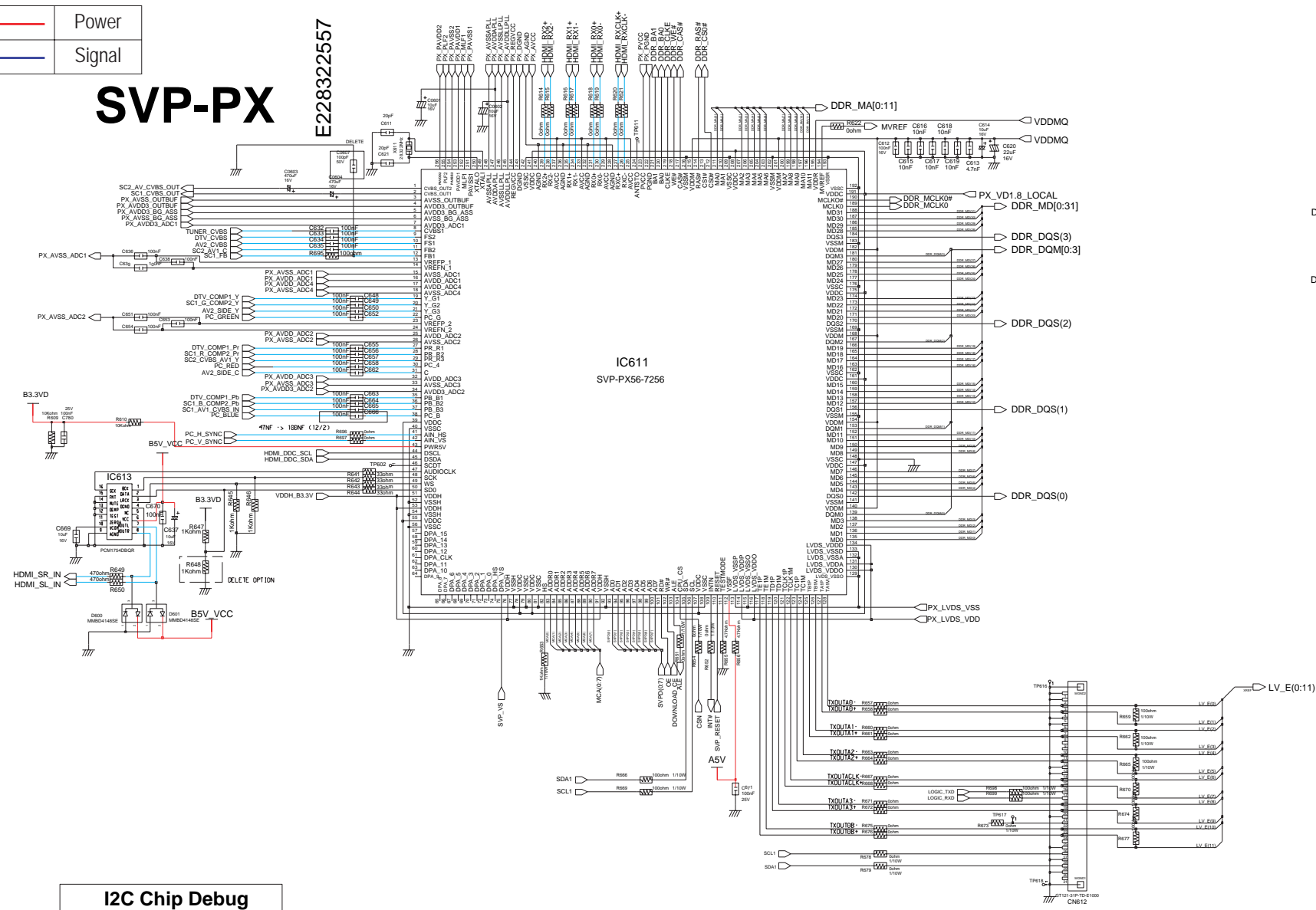

DDR

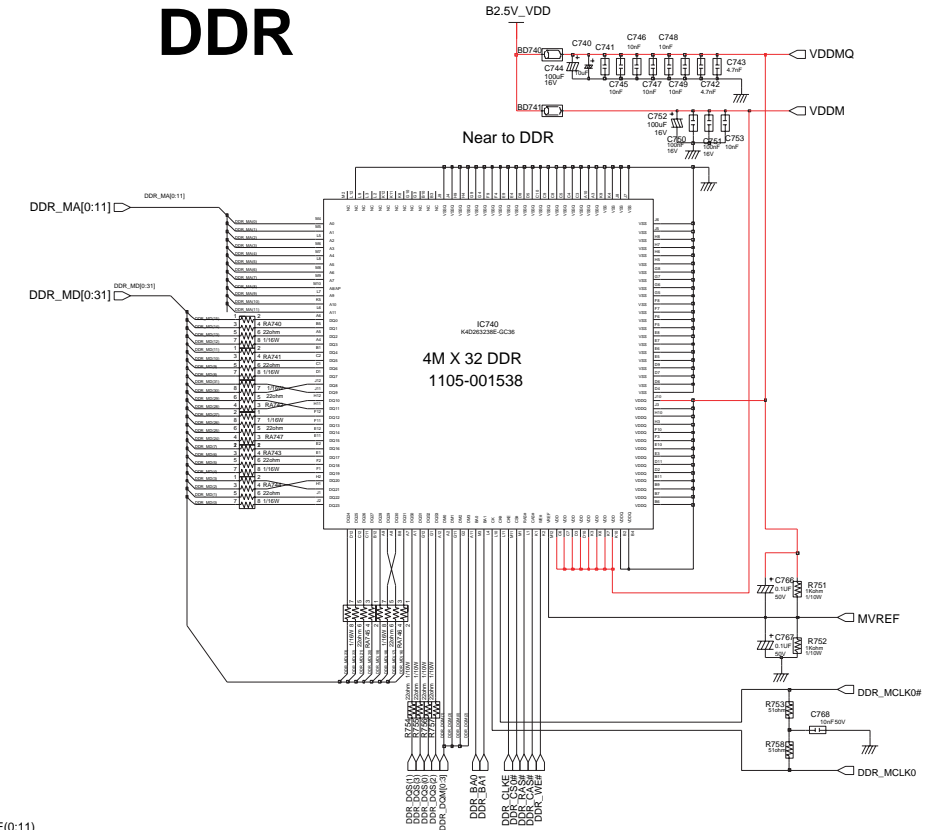

PX_Power

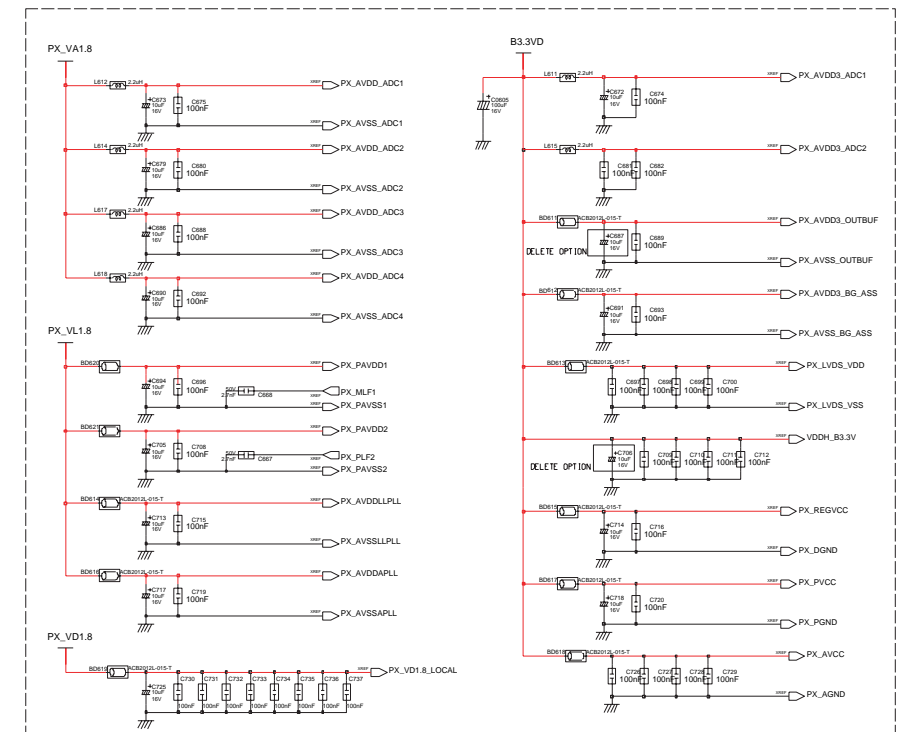

10-1-7 TUNER

This Document can not be used without Samsung's authorization.

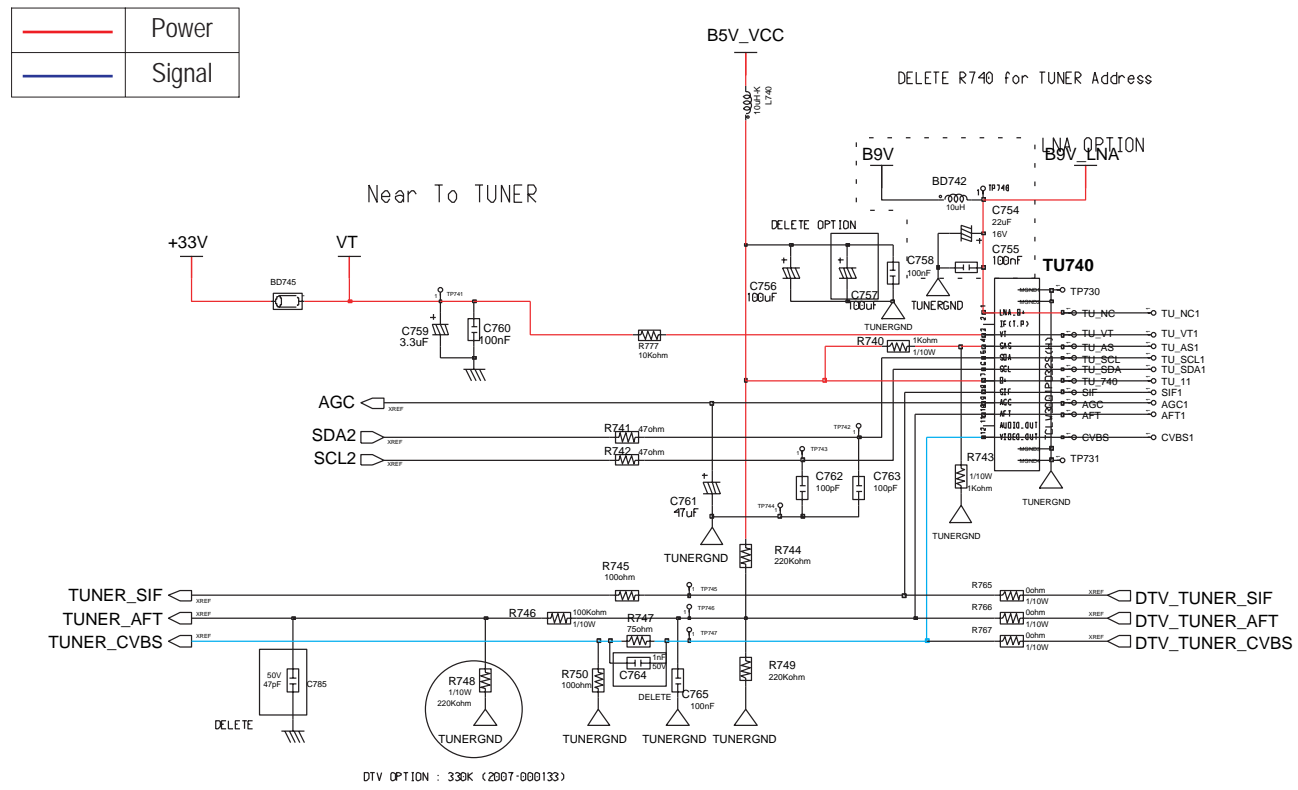

10-1-8 FUNCTION

This Document can not be used without Samsung's authorization.

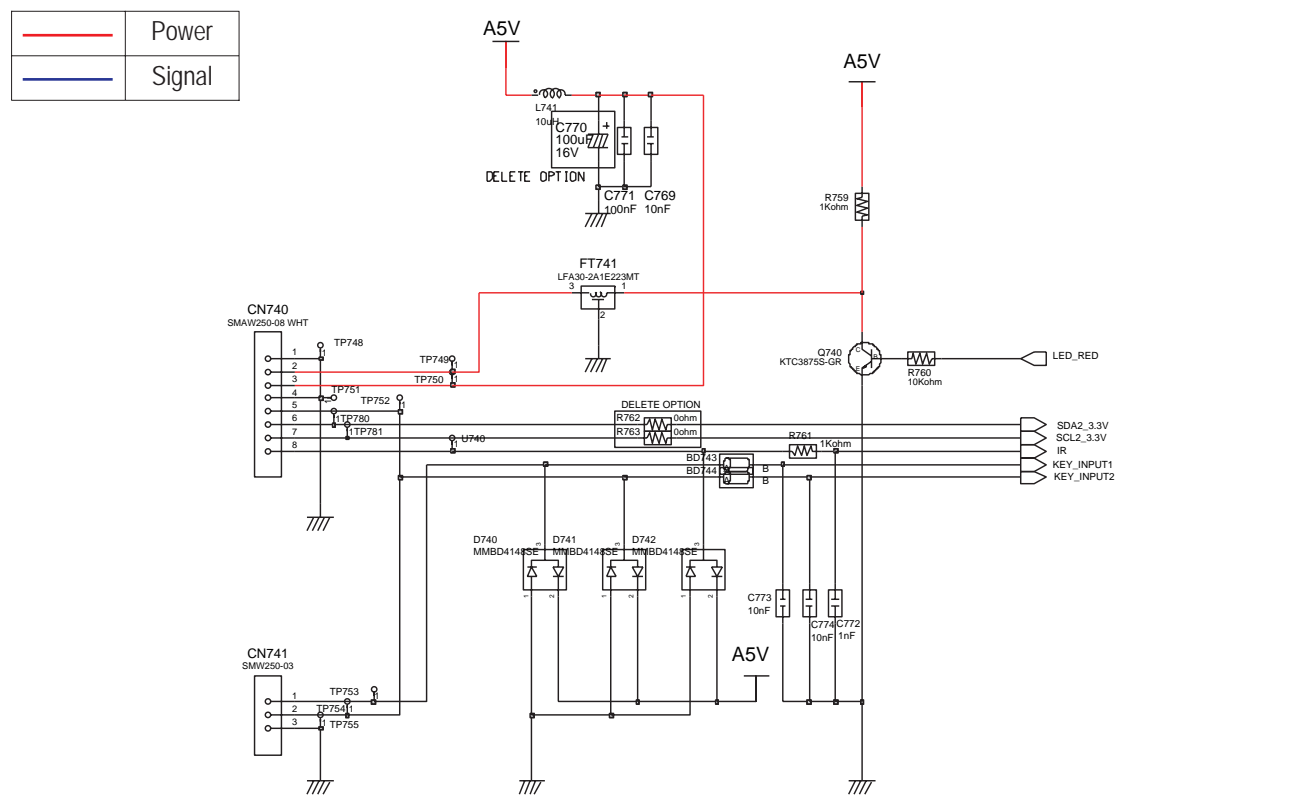

10-1-9 FBE_Option

This Document can not be used without Samsung's authorization.

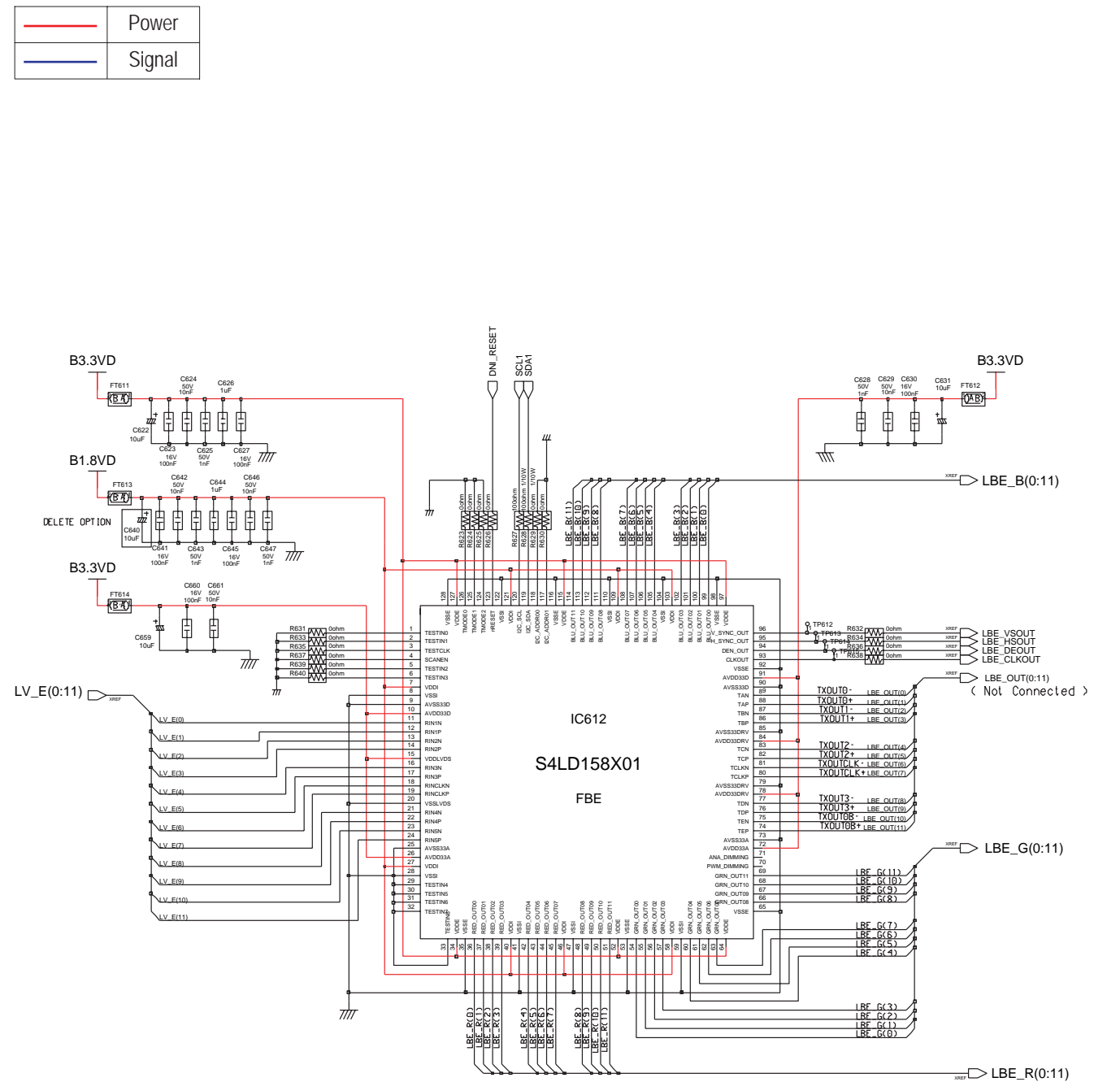

10-1-10 FRC

This Document can not be used without Samsung's authorization.

FRC

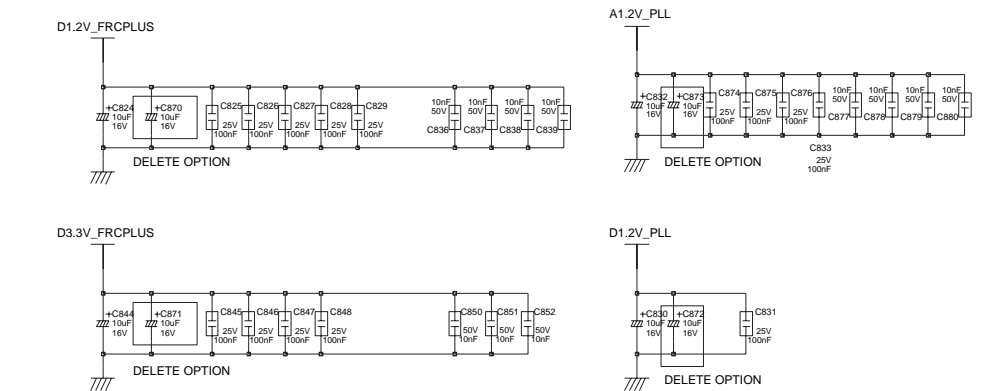
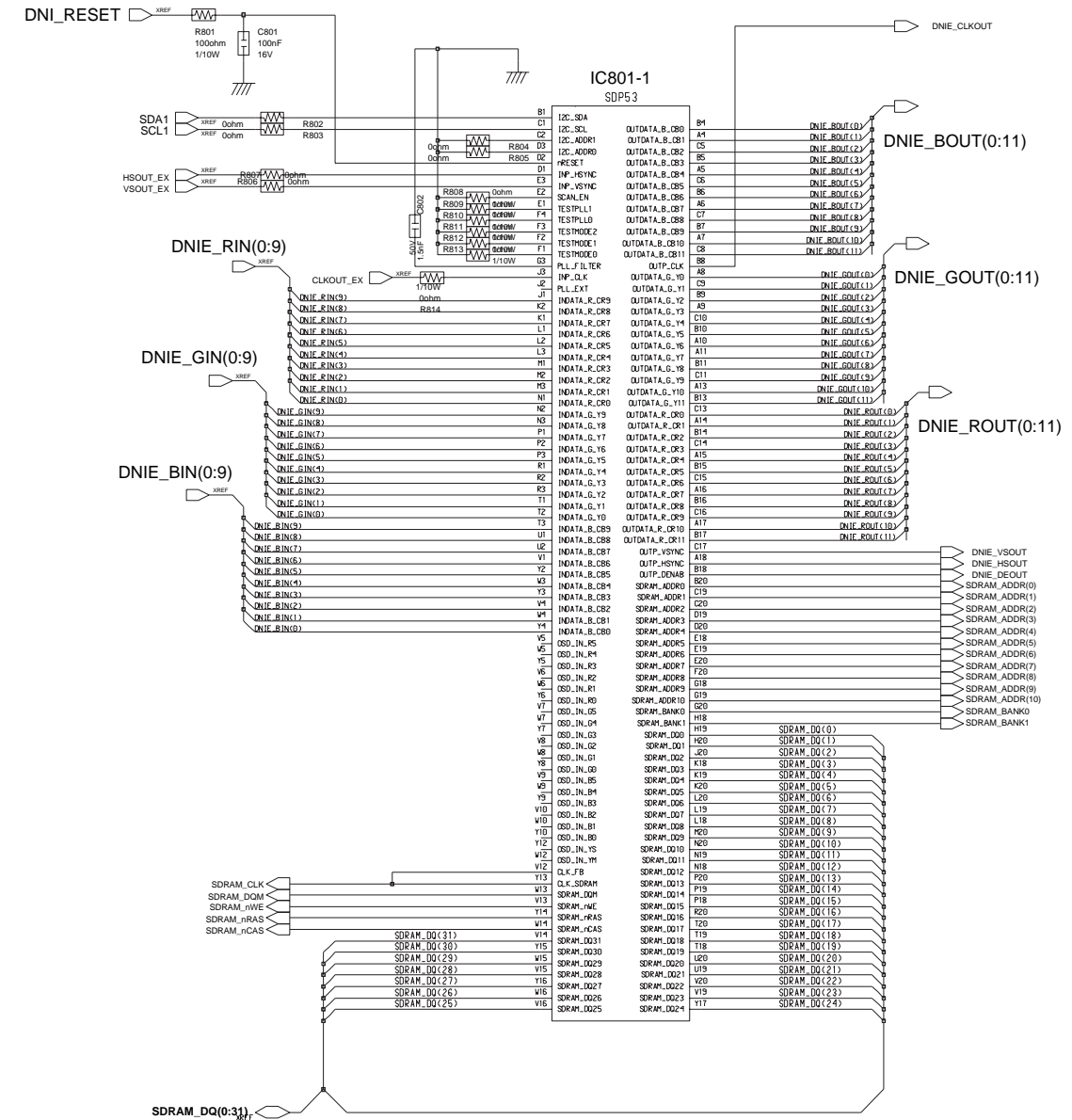
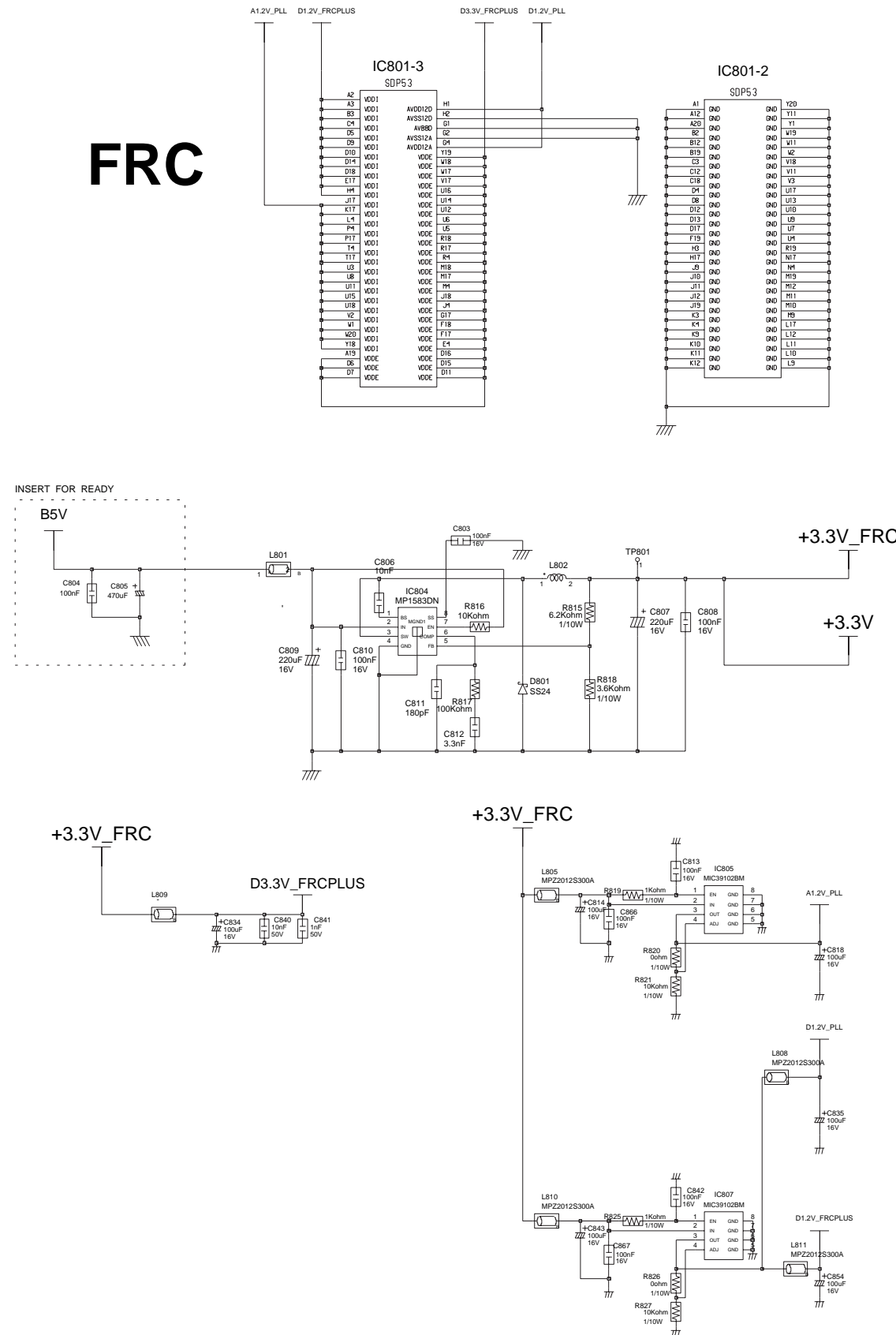

10-11 FRC Memory

This Document can not be used without Samsung's authorization.

LVDS RX (FOR FRC)

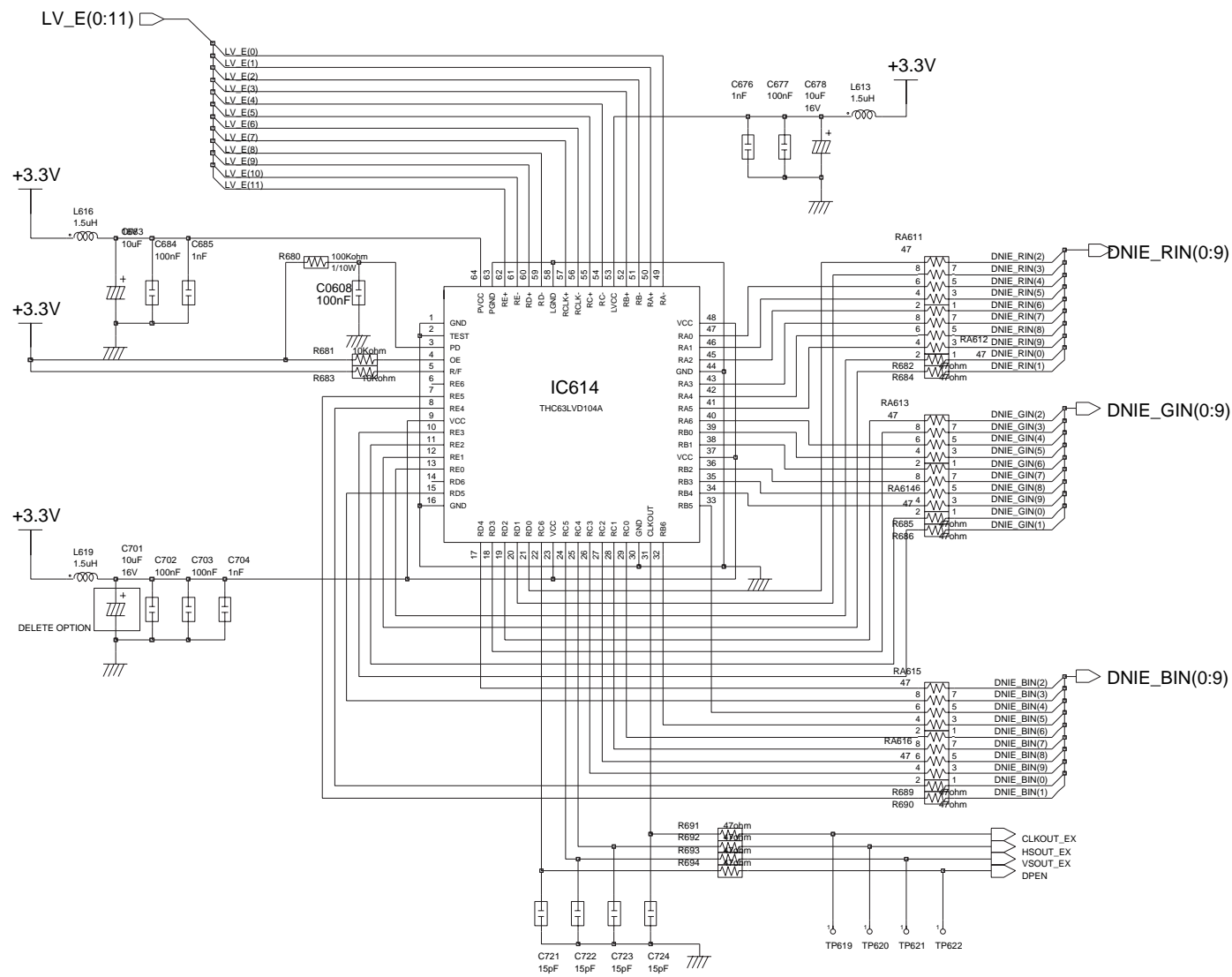

FRC Memory

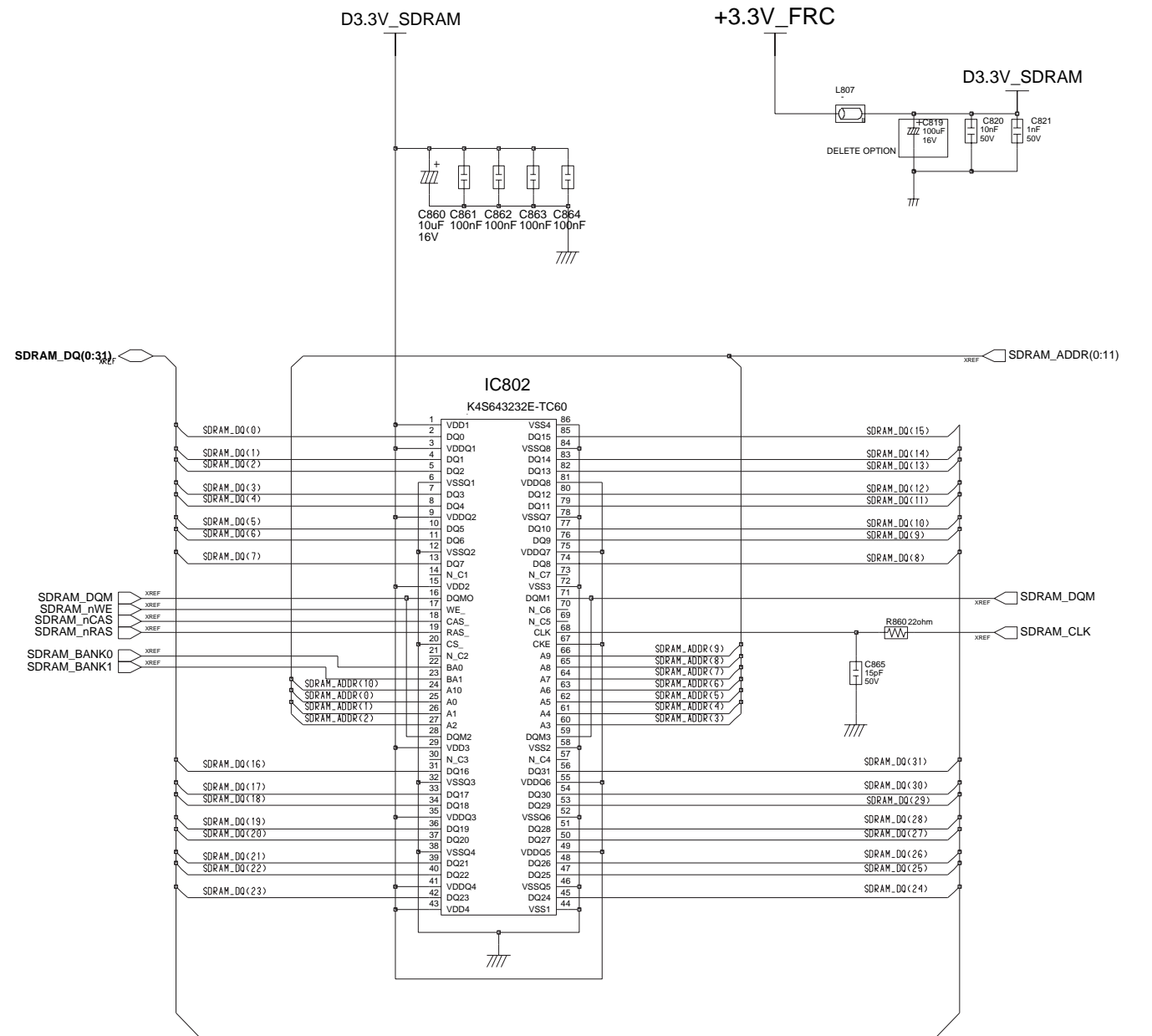

10-1-12 LVDS

This Document can not be used without Samsung's authorization.

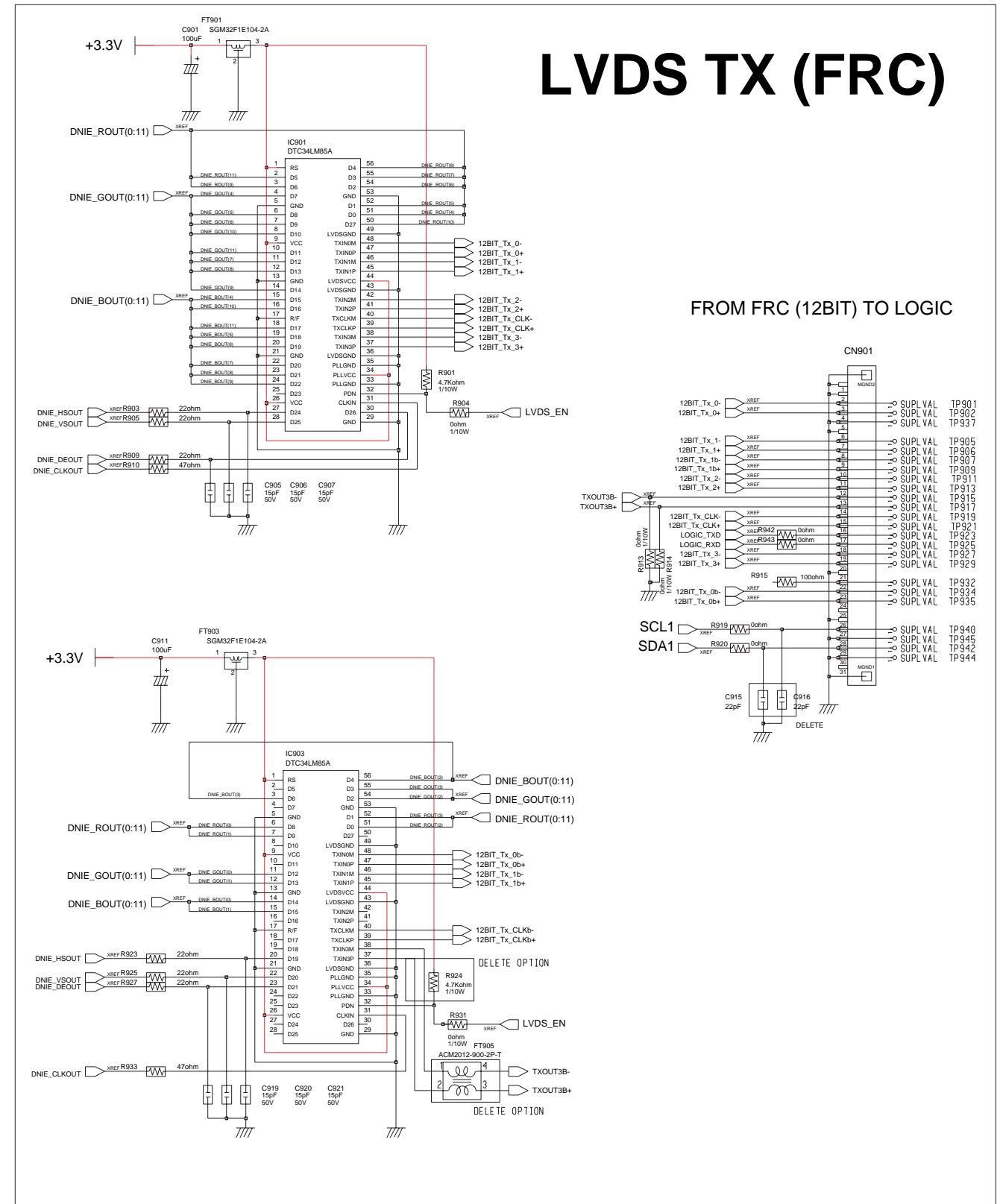
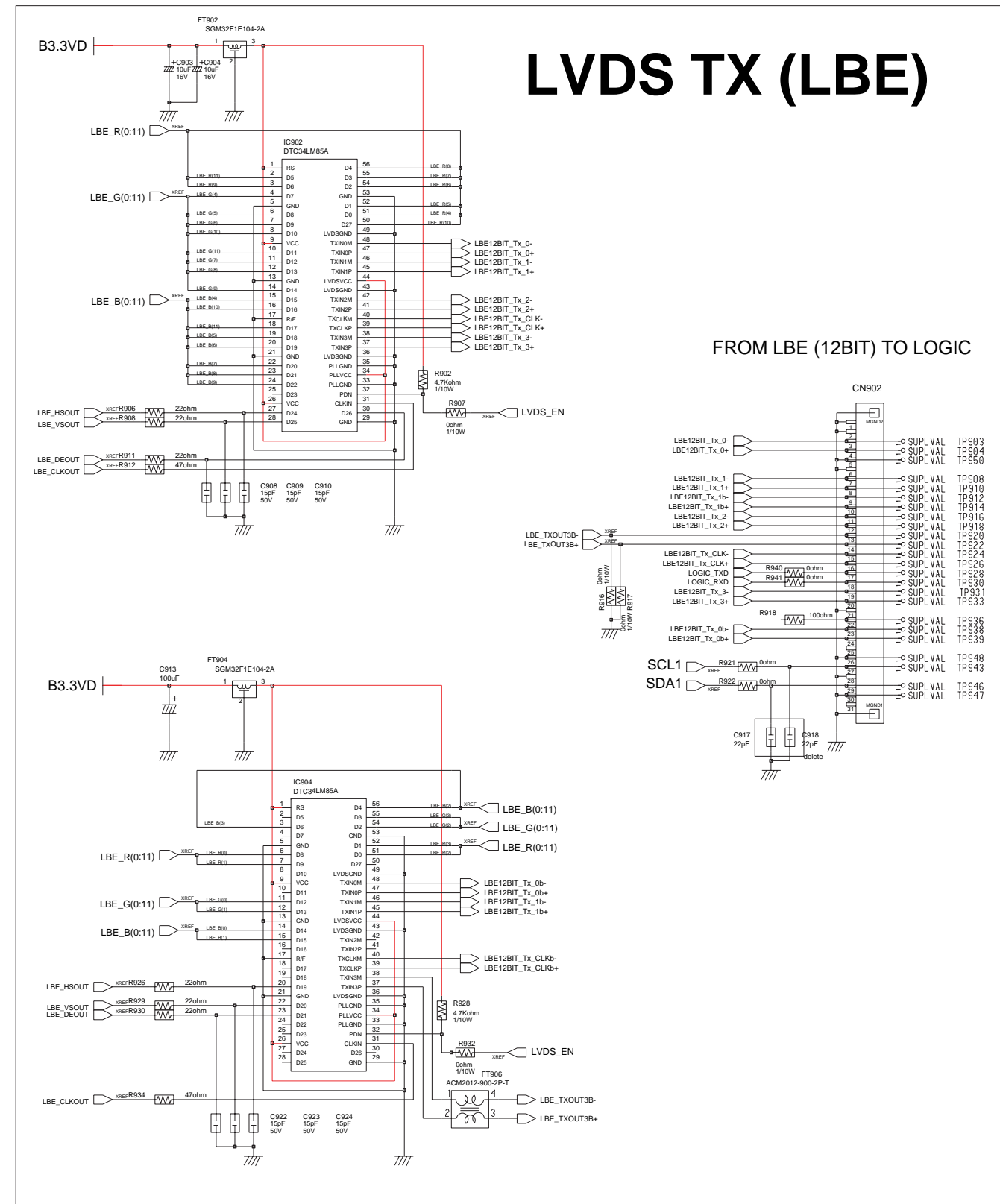

10-1-13 DTV / TUNER / POWER

This Document can not be used without Samsung's authorization.

DTV MODULE CONNECTION

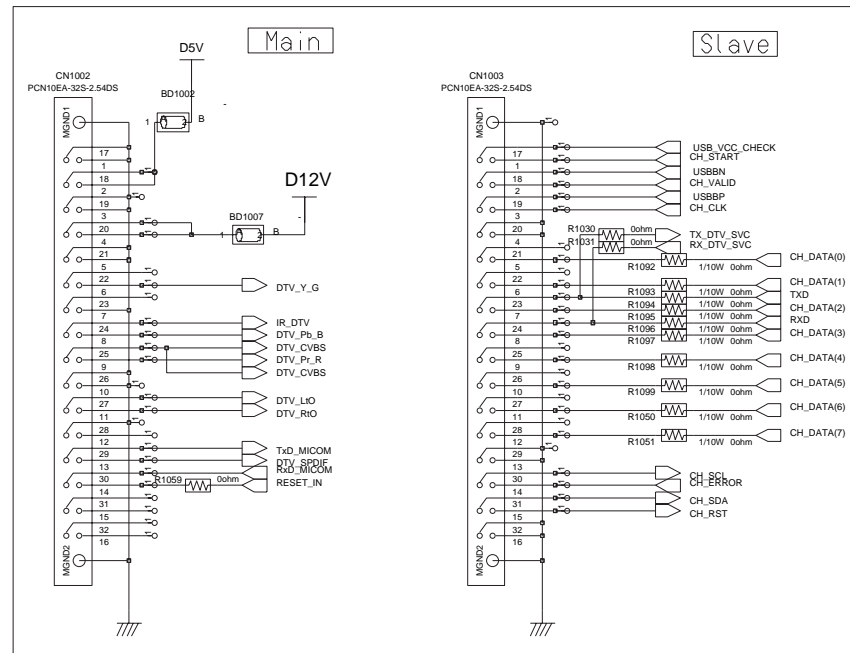

DIGITAL TUNER

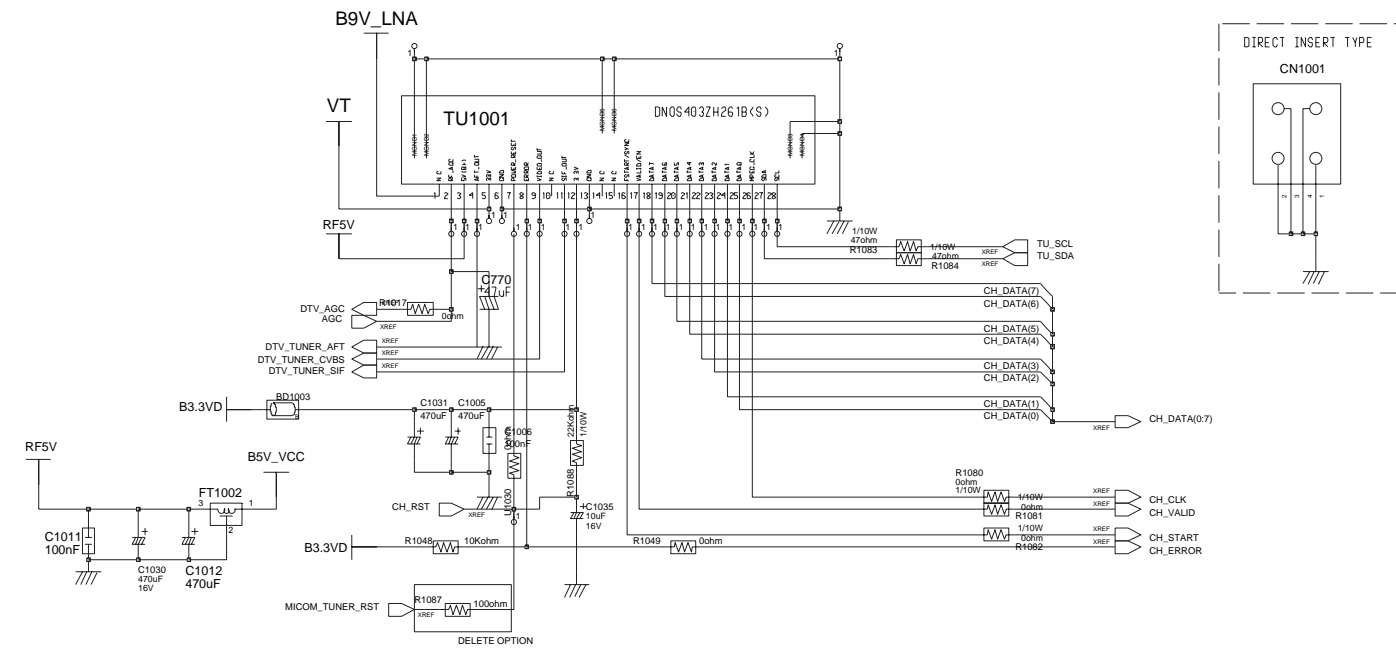

PHONE JACK

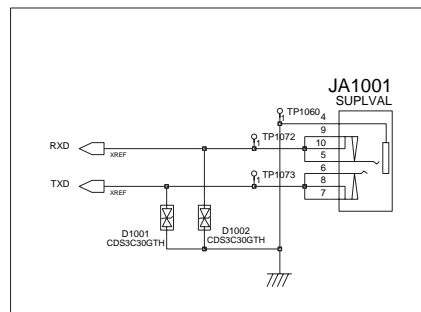

MODEM JACK

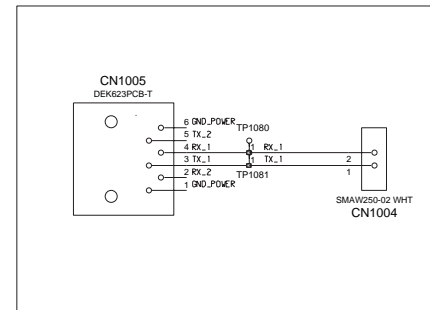

USB

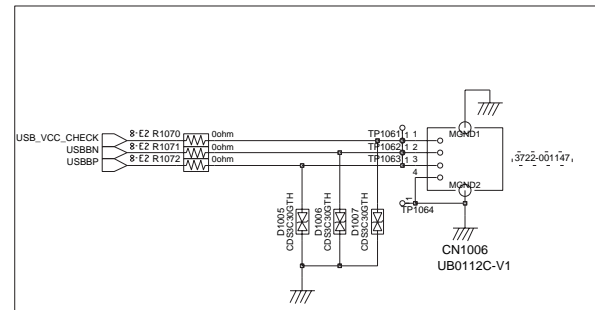

B5V_VCC

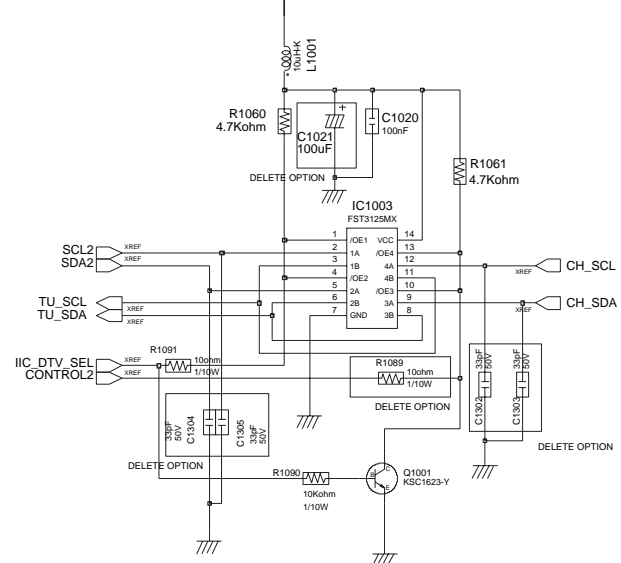

OPTICAL SPDIF OUT

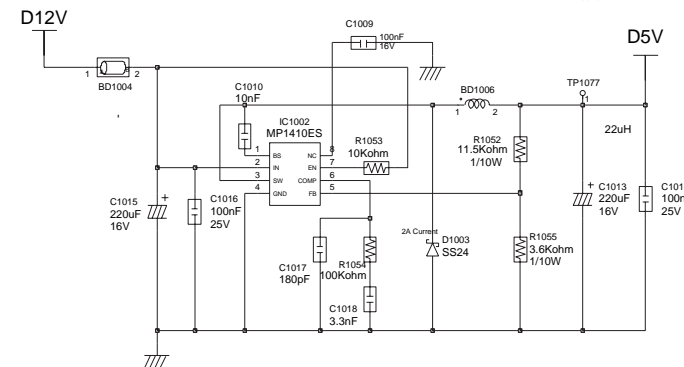
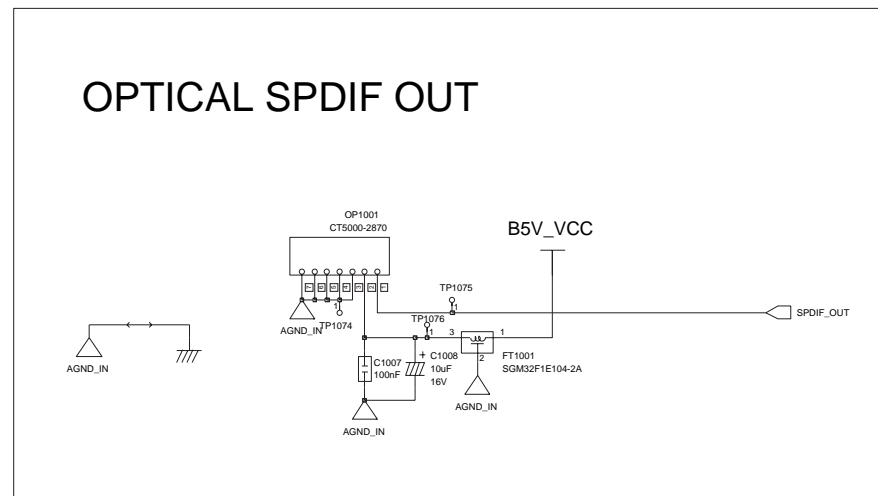

11. Operation Instruction & Installation

11-1 Product Features and Functions

11-1-1 Front (or Side) Panel

Front (or Side) Panel

PS-42E7H/PS-42E7S

PS-42E71H

1 SOURCE
Displays a menu of all of the available input sources (TV, Ext.1, Ext.2, AV, S-Video, Component, PC, HDMI).

2 MENU
Press to see the on-screen menu of your TV's features.

3 \leftarrow \rightarrow +
Press to decrease or increase the volume.
In the on-screen menu, use the \leftarrow \rightarrow + buttons as you use the \odot and \surd buttons on the remote control.

4 \surd C/P. \odot \leftarrow
Press to change channels. In the on-screen menu, use the \surd C/P. \odot \leftarrow buttons as you use the \blacktriangle and \blacktriangledown buttons on the remote control.

5 \rightarrow (ENTER)
Press to confirm a selection.

6 \odot (Power) button
Press to turn the TV on and off.

Power Indicator
- Power Off: Red
- Power On: Off

Remote Control Sensor
Aim the remote control towards this spot on the TV.

1 SOURCE

2 MENU

3 \leftarrow \rightarrow +

4 \surd C/P. \odot \leftarrow

5 \rightarrow (ENTER)

6 \odot (Power) button

Side Panel

1 S-Video or Video / Audio L/R
- Video (S-Video or Video) and audio inputs for external devices, such as a camcorder or VCR.

2 headphones jack
- You can connect a set of headphones to your television if you wish to watch a television programme without disturbing the other people in the room.

➤ Prolonged use of headphones at a high volume may damage your hearing.

1

2

11-1-2 Rear Panel

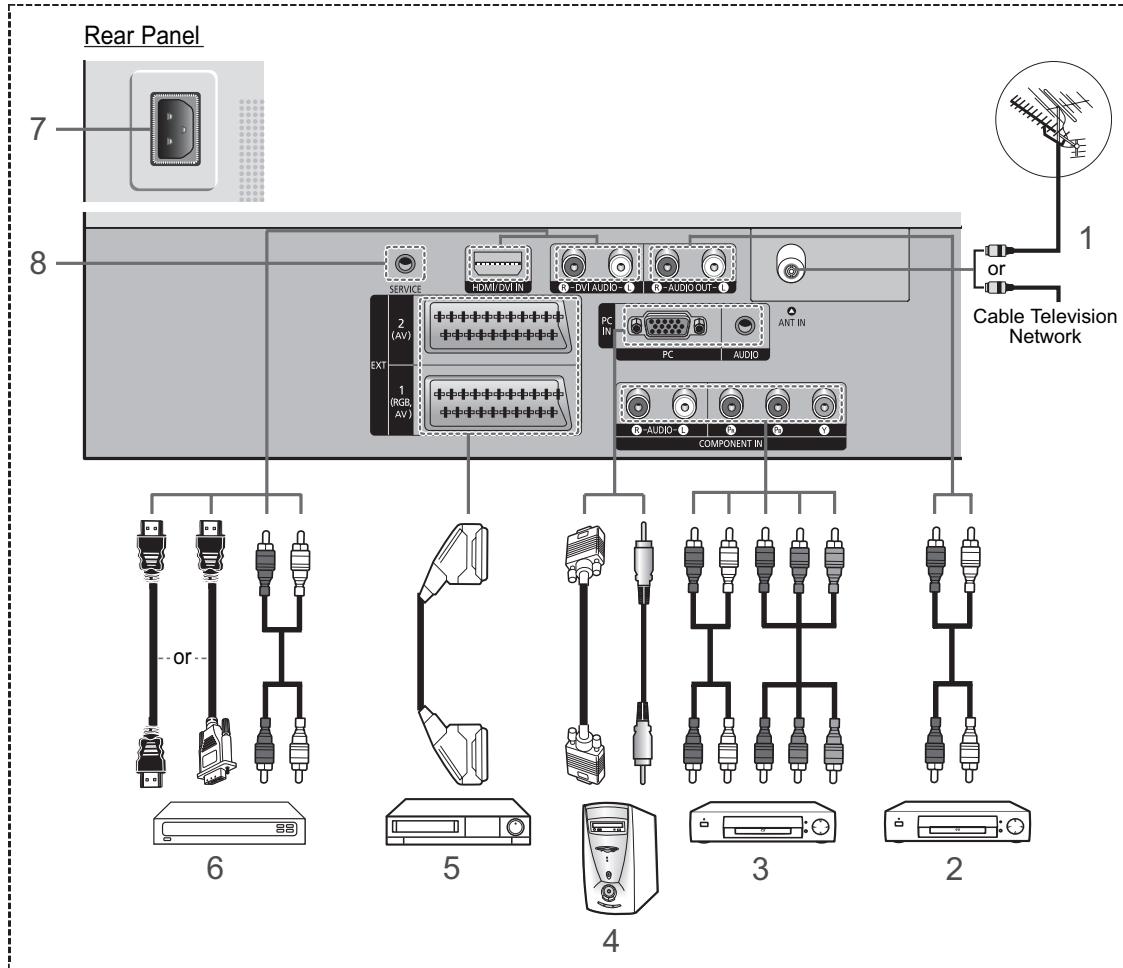

- ☛ Whenever you connect an audio or video system to your set, ensure that all elements are switched off.
- ☛ When connecting an external device, match the colour of the connection terminal to the cable.

- 1 ANT IN VHF/UHF (75Ω)
- 75Ω Coaxial connector for Aerial/Cable Network.
- 2 Connecting external Audio Devices
- Connect RCA audio signals from the TV to an external source, such as Audio equipment.
- 3 COMPONENT IN
- Audio (AUDIO R/L) and video (P_r/P_b/Y) inputs for Component.
- 4 PC IN / AUDIO
- Connect to the video and audio output jack on your PC.
- 5 EXT 1, EXT 2
- Inputs or outputs for external devices, such as VCR, DVD, video game device or video disc players.

Input/Output Specification

Connector	Input				Output
	Video	Audio (L/R)	S-Video	RGB	Video + Audio (L/R)
EXT 1	✓	✓	✓	✓	Only TV or DTV output is available.
EXT 2	✓	✓	✓	✓	Output you can choose.

- 6 HDMI/DVI IN
- Connect to the HDMI jack of a device with HDMI output. These inputs can also be used as a DVI connection with separate analog audio inputs. An optional HDMI/DVI cable will be necessary to make this connection. When using the optional HDMI/DVI adapter, the DVI analog audio inputs on

- your TV allow you to receive left and right audio from your DVI device. (Not compatible with PC)
- When connecting this product via HDMI or DVI to a Set Top Box, DVD Player or Games Console etc, make sure that it has been set to a compatible video output mode as shown in the table below. Failure to observe this may result in picture distortion, image breakup or no picture.
- Do not attempt to connect the HDMI/DVI connector to a PC or Laptop Graphics Card. (This will result in a blank screen being displayed)

DVI AUDIO IN L/R

- DVI audio outputs for external devices.

- 7 POWER IN
- Connect the supplied power cord.

- 8 SERVICE
- Connector for service only.

➤ Supported modes for HDMI/DVI and Component

	480i	480p	576i	576p	720p	1080i
HDMI/DVI 50Hz	X	O	X	O	O	O
HDMI/DVI 60Hz	X	O	X	X	O	O
Component	O	O	O	O	O	O

11-1-3 Remote Control

- | | |
|---|--|
| 1 POWER button
(turns the TV on and off) | 21 Exit the on-screen menu |
| 2 Number buttons for direct
channel access | 22 Control the cursor in the menu |
| 3 One/Two-digit channel
selection | 23 Use to see information on the
current broadcast |
| 4 Channel control button
(Refer to page 13) | 25 Picture freeze |
| 5 Selects the TV mode directly | 26 Picture size selection |
| 6 ⊕ Volume increase
⊖ Volume decrease | 27 Select the channel of sub
picture (PIP) |
| 7 Temporary sound switch-off | Teletext Functions |
| 8 Displays the main on-screen
menu | 5 Exit from the teletext display
(depending on the model) |
| 9 Picture-In-Picture On/Off | 8 Teletext index |
| 10 Sound effect selection | 9 Teletext hold |
| 11 Picture effect selection | 13 Teletext store |
| 12 Adjust screen brightness to
surrounding environment | 16 Teletext mode selection
(LIST/FLOF) |
| 14 Sound mode selection | 17 Teletext sub page |
| 15 TruSurround XT mode button | 20 P ⏪ : Teletext next page
P ⏩ : Teletext previous page |
| 16 Available source selection | 21 Teletext cancel |
| 17 Previous channel | 23 Teletext reveal |
| 18 Automatic Power-off | 24 Teletext display/mix both
teletext information and
the normal broadcast |
| 19 Selects the PC mode directly | 28 Teletext size selection |
| 20 ⏴ Next channel
⏵ Previous channel | 10 11 25 26
Fastext topic selection |

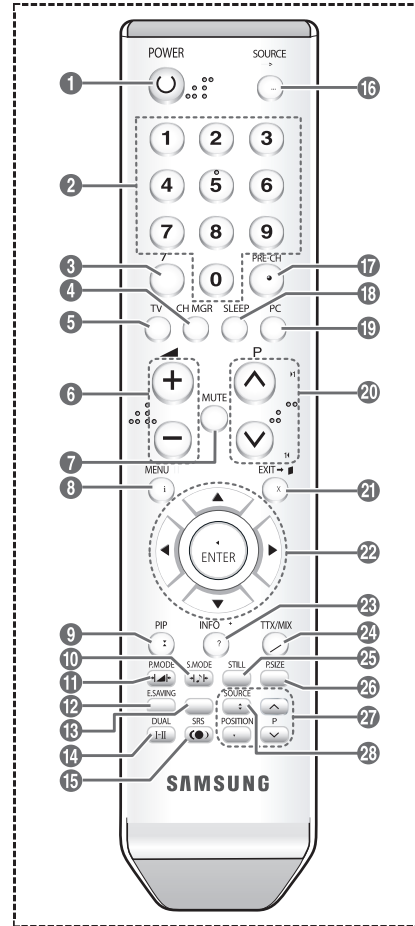

- The performance of the remote control may be affected by bright light.
- This is a special remote control for the visually impaired, and has Braille points on the Power, Channel and Volume buttons.

11-2 Installation Notes and Precautions

11-2-1 Installation Notes

1. Contact a technician for installing the wall bracket.
2. Samsung Electronics is not responsible for any damages to the product or harm to customers when the installation is done by the customer.
3. This product is for installing on cement walls. The product may not stay in place when installed on plaster or wood.
4. The package contents and parts supplied for the wall mount are subject to change without prior notice.

11-2-2 Mounting Kits

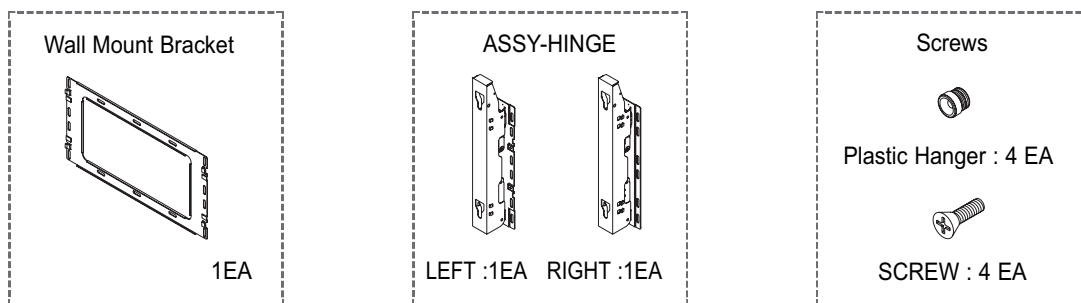

11-2-3 How to assemble the Wall Mount Bracket

- 1 The wall mount bracket is delivered separately. Please tighten the captive screw in the direction of the arrow after assembling the bracket. Install the Wall Mount Bracket after the screws are securely inserted into the wall.

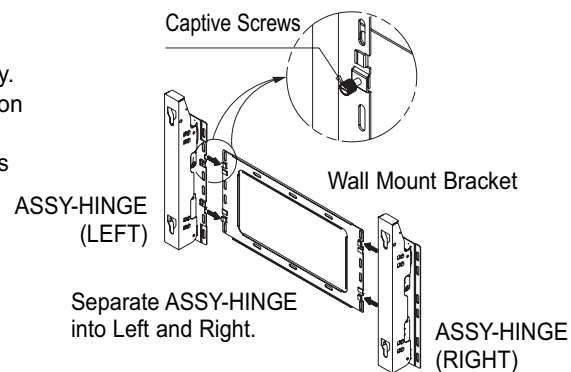

11-2-4 Instructions on Securing the SET to the Wall Mount Bracket

- 1 Remove the screws from the back of the PDP.

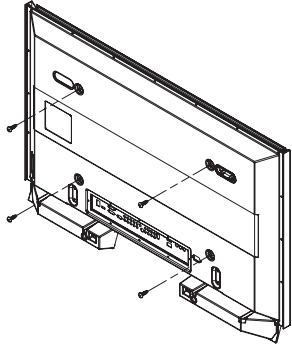

- 2 Use the screw and assemble the plastic hanger. (Please refer to the following picture.)

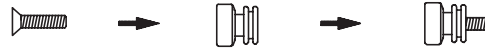

- 1 Please ask the installers to install the wall mount bracket.
- 2 Please be sure to check if the plastic hanger is completely secured on both the left and right side after hanging the SET on the wall mount bracket.
- 3 Please avoid catching your fingers while installing and adjusting the angle.
- 4 Please tightly secure the wall mount bracket to the wall to avoid injury from a falling SET.

- 3 Tighten the screws of the plastic hanger (shown in picture 2) to the back side of the PDP.

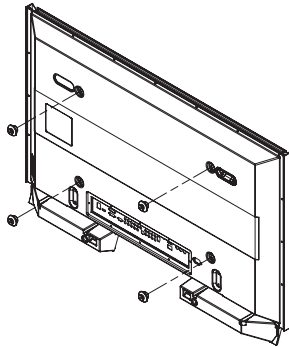

- 4 Remove the Safety Pins. Fasten the 4 plastic latches assembled at step (3) on the back side of the PDP using the guide holes of the wall mount, push (1) and hook (2) down to secure the PDP on the wall mount as illustrated. Secure the PDP by inserting the Safety Pins, not to fall from the wall mount.

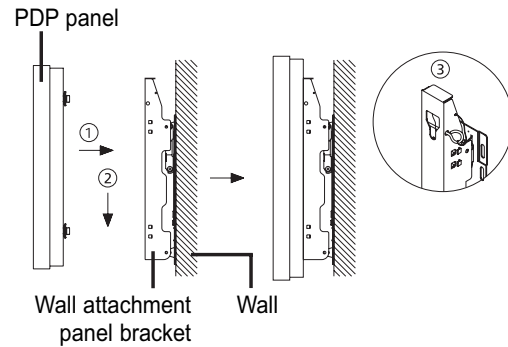

11-2-5 How to Adjust Mounting Angle

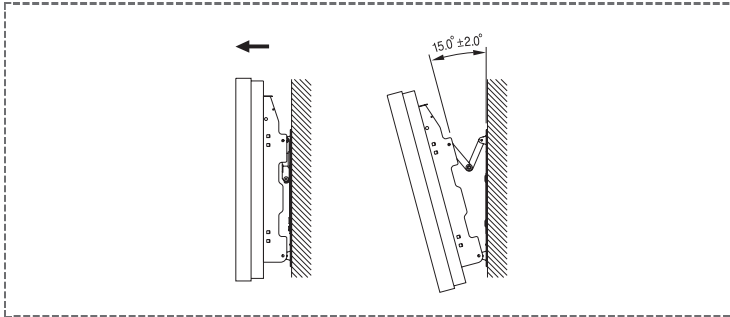

- 1 Secure the SET to the wall mount bracket.(Please refer to the following instructions.)
- 2 Set the angle by pulling the upper end of the SET attached to bracket in the direction of the arrow. (Refer to the illustration on the right.)
- 3 The angle can be adjusted from 0° to 15° by $\pm 2^\circ$.

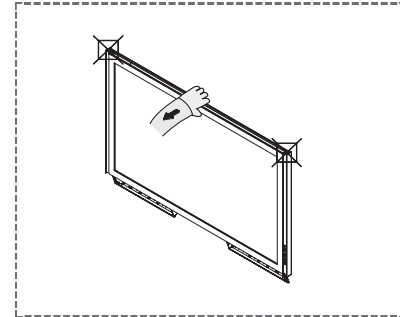

Hold onto the middle of the PDP to adjust the angle (not the sides of the PDP).

11-2-6 Connecting External Devices to the PDP

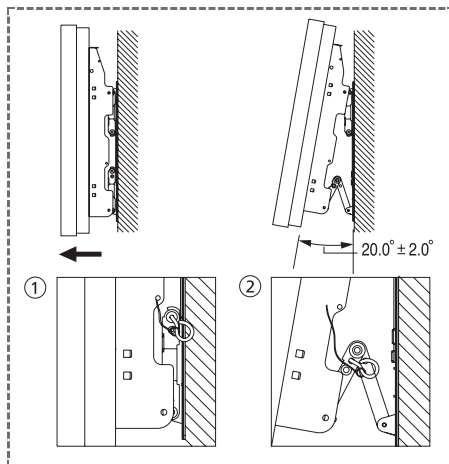

- 1 Be sure to remove the safety pins underneath the PDP.
 - If the safety pins are not removed, the angle cannot be adjusted. Any attempt to do so may cause damage to the PDP.
- 2 Hold onto the bottom of the PDP and pull forward fully as directed by the arrow as illustrated) to adjust the angle. (0°~20° by 2°) Insert the Safety Pins to the front guide holes on both sides as illustrated in figure ②.
 - Viewing the PDP after connecting the external devices Remove the Safety Pins to adjust the angle to 0°, and then secure the Safety Pins again.
 - ☝ For safety, be sure to secure the PDP using the safety pins. If the safety pins are not used, the PDP may fall, causing serious injury.

3. Alignment & Adjustment

3-1 Service Instruction

■ Before Performing After Sales Services

1. Check if the measurement and test equipment is working properly.
2. Secure sufficient work space for disassembling the product.
3. Prepare a soft pad for disassembling the product.

3-2 How to Access Service Mode

1. General Remote

To Enter : Power Off → INFO → MENU → MUTE → Power On
(Interval between key strokes : less than 3 sec)

To Exit : Power Off → On

2. Factory Remote

To Enter : Power On → INFO → FACTORY Key (Interval between key strokes : less than 3 sec)

To Exit : Power Off → On

Press the Factory key twice with a key stroke interval of more than 1 second (Pressing once enters Aging Mode)

3. Settings when entering Factory mode

- Sharp Screen (Dynamic), Color Tone (Cool1), Factory (Dynamic CE Off)

4. Adjustment Procedures

- Channel ▲▼ Key : Select an item.
- Volume ◀▶ Key : Adjust the value up or down.
- MENU Key : Save the changes to the EEPROM and return to the higher-level mode.
- Using the Numeric (0~9) keys, you can select a channel.
- Using the SOURCE key, you can switch AV modes.

5. Initial SERVICE MODE DISPLAY State

```
1. Calibration
2. Option Table XXXX XXXX
3. White Balance
4. SVP-PX
5. Option Block
6. STV8257/STA323W
7. YC Delay
8. Adjust
9. -----
10. W/B MOVIE
11. Checksum
12. Reset
13. -----
    T-AUD42PEAS-XXXX (Main Micom Ver)
    T-AUD42PEUHS-XXXX (Sub Micom Ver)
    Month / Day / Year / Hour / Min. / Sec.
```

※ The version of the firmware displayed at the bottom of the screen may differ and the firmware is subject to change for the improvement of product functions.

※ If you have adjusted the settings in Service Mode, you have to reset the product.

3-3 Factory Data

★ The underlined are items applied during the service adjustment. None of the others should be adjusted.

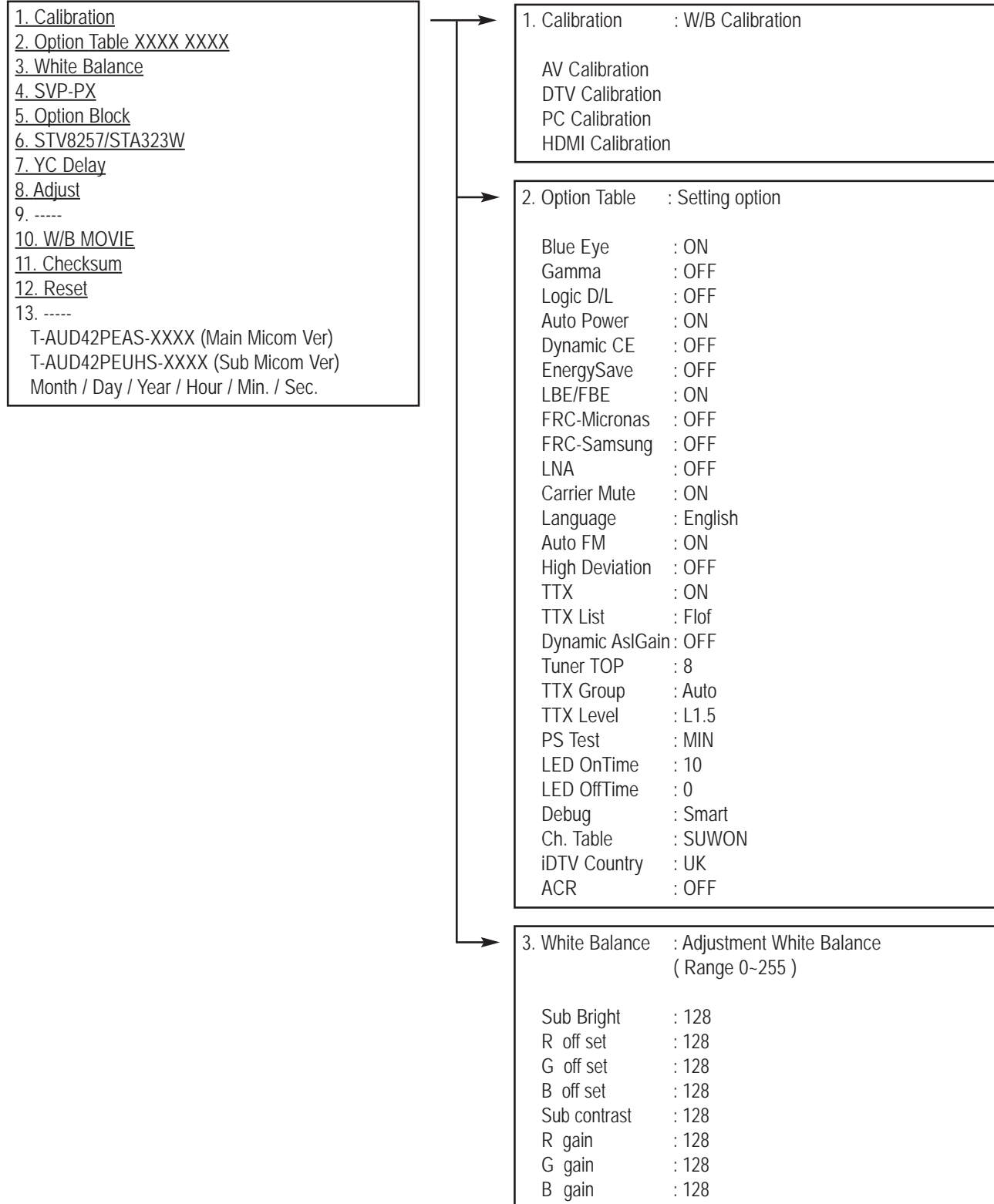

- 1. Calibration
- 2. Option Table XXXX XXXX
- 3. White Balance
- 4. SVP-PX
- 5. Option Block
- 6. STV8257/STA323W
- 7. YC Delay
- 8. Adjust
- 9. -----
- 10. W/B MOVIE
- 11. Checksum
- 12. Reset
- 13. -----
- T-AUD42PEAS-XXXX (Main Micom Ver)
- T-AUD42PEUHS-XXXX (Sub Micom Ver)
- Month / Day / Year / Hour / Min. / Sec.

4. SVP-PX : SVP-PX Correct Register

ComB Filter : Y-Filter - 80H

Sharpness :

	RF/AV	COMP	PC	HDMI
H2Gain	0DH	10H	10H	08H
H4Gain	04H	04H	04H	00H
V2Gain	0CH	10H	10H	08H
V4Gain	04H	04H	04H	04H
Sr2Gain	00H	00H	00H	00H
Sr4Gain	00H	00H	00H	00H
SI2Gain	00H	00H	00H	00H
SI4Gain	00H	00H	00H	00H
Peakth1	00H	00H	00H	00H
Peakth2	80H	80H	80H	80H
Peakth3	00H	00H	00H	00H

NR :

YNROFF	80H
CNROFF	80H
YNRON	80H
CNRON	80H

RGB Calibration :

	RF/AV	COMP	PC	HDMI
R-Offset	4EH	4BH	48H	3BH
G-Offset	4EH	4BH	48H	3BH
B-Offset	4EH	4BH	48H	3BH
R-Gain	7CH	7BH	80H	9DH
G-Gain	7CH	7BH	80H	9DH
B-Gain	7CH	7BH	80H	9DH

ADC Calibration :

	RF/AV	COMP	PC	HDMI
TCD3 Contrast	84H	78H	78H	78H
TCD3 Brightness	23H	20H	20H	20H
TCD3 CR	80H	80H	80H	80H
TCD3 CB	80H	80H	80H	80H
TCD3 Delay	00H	00H	00H	00H
Analog Y Offset	40H	40H	42H	40H
Analog PB Offset	80H	80H	39H	80H
Analog PR Offset	80H	80H	39H	80H
Analog Y Gain	D6H	CBH	CFH	D6H
Analog PB Gain	FEH	9AH	80H	FEH
Analog PR Gain	FEH	9AH	80H	FEH
Black Level	00H	00H	00H	00H
SVP Brightness	00H	00H	00H	00H

Calibration Target :

	low	high	delta
AV ADC	10H	F8H	04H
COMP ADC	10H	F8H	04H
PC ADC	04H	F8H	04H
ALL RGB	04H	F8H	10H

1. Calibration
 2. Option Table XXXX XXXX
 3. White Balance
 4. SVP-PX
 5. Option Block
 6. STV8257/STA323W
 7. YC Delay
 8. Adjust
 9. -----
 10. W/B MOVIE
 11. Checksum
 12. Reset
 13. -----
 T-AUD42PEAS-XXXX (Main Micom Ver)
 T-AUD42PEUHS-XXXX (Sub Micom Ver)
 Month / Day / Year / Hour / Min. / Sec.

5. Option Block

FRC-Micronas		
FRC-Samsung		
LBE/FBE	: Test Pattern	00H
	Black Stretch Tilt	50H
	Black Stretch Gain	55H
	Black Stretch Ratio	33H
	Skin En	01H
	Skin Gain	80H
	Skin T X	70H
	Skin T Y	64H
	White En	00H
	MCM Gain	80H
	White T X	4FH
	White T Y	54H
	CHY Gain1	3EH
	CHY Gain2	42H
	CHC Gain1	40H
	CHC Gain2	40H
	CHM Gain1	3DH
	CHM Gain2	45H
	ColorGain TY	00H
	ColorGain TC	00H
	ColorGain TM	00H
	Color Gain	80H
	Input RGB Gain	80H
	Input RGB Offset	00H

6. STV8257/STA323W : Sound IC Correct Register

Ch1 Volume	: 55H
Ch2 Volume	: 55H
AGC Gain	: 07H
AM Prescale	: 00H
ZWT TH	: 0AH
AV Delay	: 55H
Comp Delay	: 32H
HDMI Delay	: 32H
PC Delay	: 32H
L1 Att/Rel Th	: EFH

<u>1. Calibration</u>
<u>2. Option Table XXXX XXXX</u>
<u>3. White Balance</u>
<u>4. SVP-PX</u>
<u>5. Option Block</u>
<u>6. STV8257/STA323W</u>
<u>7. YC Delay</u>
<u>8. Adjust</u>
9. -----
<u>10. W/B MOVIE</u>
<u>11. Checksum</u>
<u>12. Reset</u>
13. -----
T-AUD42PEAS-XXXX (Main Micom Ver)
T-AUD42PEUHS-XXXX (Sub Micom Ver)
Month / Day / Year / Hour / Min. / Sec.

<u>7. YC Delay</u>	
PAL B/G	: 99H
PAK D/K	: 88H
PAL I	: 88H
SECAM B/G	: 88H
SECAM D/K	: 77H
SECAM L/L'	: 66H
NTSC 3.58	: 96H
NTSC 4.43	: CCH
AV PAL	: A9H
AV SECAM	: 66H
AV NT3.58	: 98H
AV NT4.43	: CCH
AV PAL60	: 77H

<u>8. Adjust</u>	
V Mute Time	: 10
Melody Volume	: 9
Ana_Dimm_Max	: FEH
TTX Contrast	: 50
TTX Brightness	: 50
TTX Color	: 50
Dynamic Contrast	: 100
Dynamic Sharpness	: 60
Standard Contrast	: 90
Standard Brightness	: 80
Standard Color	: 70
Standard Sharpness	: 70
Movie Contrast	: 60
Movie Brightness	: 50
Movie Color	: 50
Movie Sharpness	: 40
LNA PLUS	: RFDB-1 Level 2
	RFDB-2 Level 5
	RFDB-3 Level 9
	RFDB-4 Level 24
Hotel Option	: Hotel Mode OFF
	PWR On CH 1
	PWR On Vol. 10
	Max Volume 100
	L.Key Lock OFF
	PWR On Src RF

9. -----

- 1. Calibration
- 2. Option Table XXXX XXXX
- 3. White Balance
- 4. SVP-PX
- 5. Option Block
- 6. STV8257/STA323W
- 7. YC Delay
- 8. Adjust
- 9. -----
- 10. W/B MOVIE
- 11. Checksum
- 12. Reset
- 13. -----
- T-AUD42PEAS-XXXX (Main Micom Ver)
- T-AUD42PEUHS-XXXX (Sub Micom Ver)
- Month / Day / Year / Hour / Min. / Sec.

	RF/AV	COMP	PC	HDMI
10. W/B MOVIE				
WB Movie	OFF	OFF	OFF	OFF
Color Mode	Movie	Movie	Movie	Movie
Color Tone	Warm2	Warm2	Warm2	Warm2
W1 R Gain	130	129	130	134
W1 B Gain	117	118	119	120
W1 R Offset	138	137	138	138
W1 B Offset	119	114	115	122
W2 R Gain	132	133	134	136
W2 B Gain	115	114	115	116
W2 R Offset	141	140	141	141
W2 B Offset	115	112	113	116
Movie Contrast	70	70	70	70
Movie Brightness	50	50	50	50
Movie Color	45	45	45	45
Movie Sharpness	25	25	25	25

11. Checksum

12. Reset

13. -----

3-4 Service Adjustment

3-4-1 White Balance - Calibration

If picture color is wrong, do calibration first.

Execute calibration in Factory Mode

1. Source : VIDEO
2. Setting Mode : PAL Video (MODE : #2)
3. Pattern : Pattern #24 (Chess Pattern)
4. Use Equipment : K-7256 or Equipment of equality level
5. Work order
 - 1) Enter by Factory Mode select "1.CALIBRATION".
 - 2) Select "AV CALIBRATION" again in CALIBRAION MENU.
 - 3) After Completing Calibration, come out "Av success". OSD on the screen (bottom-side) for about 3 seconds.

Source AV : PAL composite, Component : 1280*720/60Hz
PC : 1024*768/60Hz

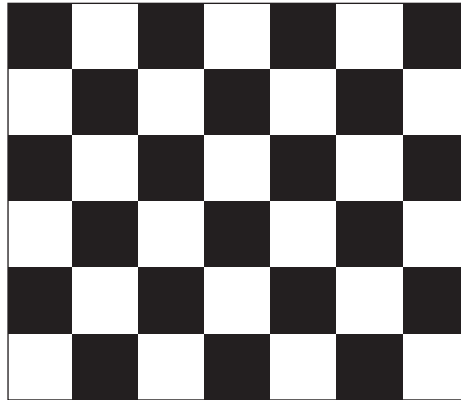

(Chess Pattern)

3-4-2 White Balance - Adjustment

If picture color is wrong, check White Balance condition.

Equipment : CA210, Patten : Toshiba
Adjust W/B in Factory Mode

Sub brightness and R/G/B Offset controls low light region
Sub contrast and R/G/B Gain controls high light region
Source AV : PAL composite, Component : 1280*720/60Hz,
HDMI[DVI] : 1280*720/60Hz

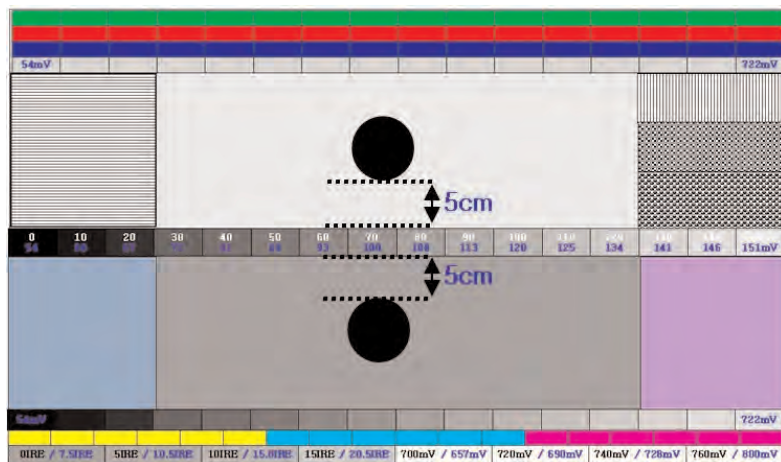

(SAMSUNG WHITE BALANCE Adjustment PATTERN with FPD)

[Test Pattern : MSPG-945 Series Pattern #16]

* Color temperature
1500K +/-500, -6 ~-20 MPCD

* Color coordinate
H/L : 270/280 +/- 2
L/L : 270/280 +/- 3, 2.1 Ft +/-0.05 Ft

3-4-3 Conditions for Measurement

1. On the basis of toshiba ABL pattern : High Light level (57 IRE)
 - INPUT SIGNAL GENERATOR : MSPG-925LTH
 - * Mode No 2 : 744X484@60 Hz
 - No 6 : 1280X720@60 Hz
 - No 21 : 1024X768@60 Hz
 - * Pattern No 36 : 16 Color Pattern
 - No 16 : Toshiba ABL Pattern

2. Optical measuring device : CA210 (FL)
Please use the MSPG-925 LTH generator for model PS-42E7S / PS-42E7SS / PS-42C7S.

3-4-4 Method of Adjustment

1. Adjust the white balance of AV, Component and DVI Modes.

(AV → Component)

a) Set the input to the mode in which the adjustment will be made (RF → DTV → PC → DVI).

- * Input signal - VIDEO Mode : Model #2 (744*484 Mode), Pattern #16
- DTV, DVI Mode : Model #6 (1280*720 Mode), Pattern #16
- HDMI Mode : Model #6 (1280*720 Mode), Pattern #16

b) Enter factory color control, confirm the data.

c) Adjust the low light. (Refer to table 1, 2 in adjustment position by mode)

- Adjust sub - Brightness to set the 'Y' value.
- Adjust red offset ('x') and blue offset ('y') to the color coordinates.

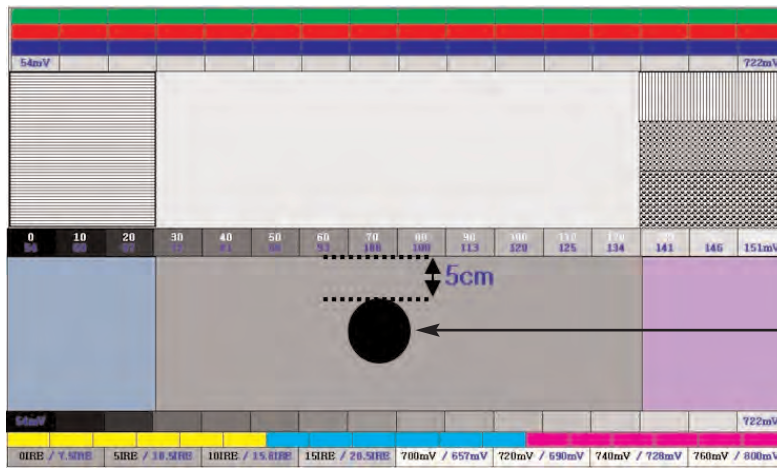

Low light
Measurement point

(SAMSUNG WHITE BALANCE Adjustment PATTERN with FPD)

* Do not adjust green offset data.

d) Adjust the high light. (Refer to table 1, 2 in adjustment position by mode)

- Adjust red gain ('x') and blue gain ('y') to the color coordinates.

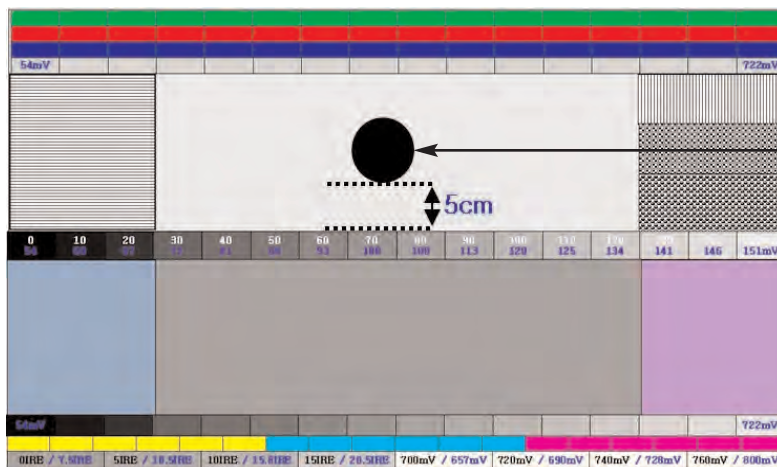

Hight light
Measurement point

(SAMSUNG WHITE BALANCE Adjustment PATTERN with FPD)

* Do not adjust the green gain and sub-contrast (Y) data.

3-5 Software Upgrade

3-5-1 How to Update Flash ROM

1. Install the Flash Downloader

Connect Set (Service Jack) and Jig Cable to execute Program Update.



2. Flash Downloader program update

- Before Turning on the set, Click "connect" which is under of OSD Screen.
- Turn on the Set.

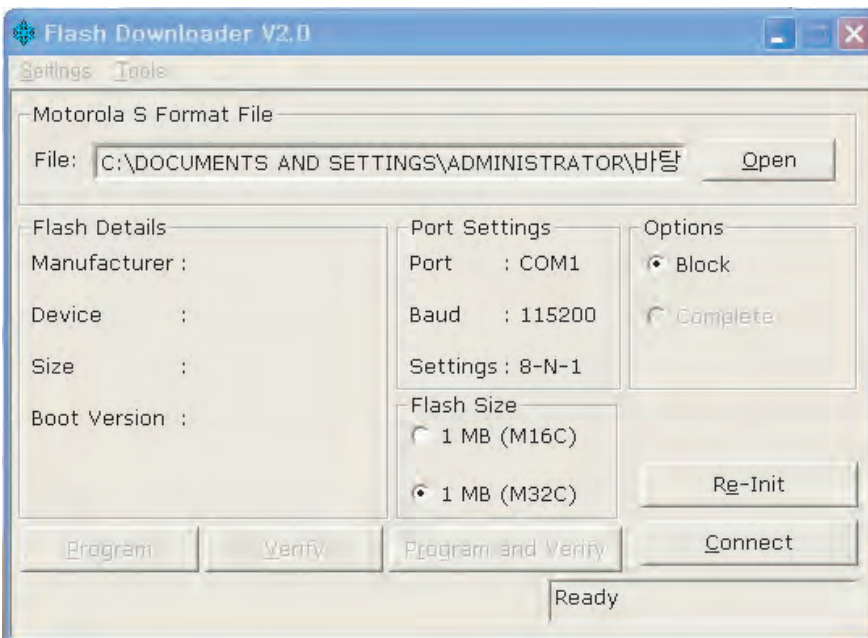

3-6 Replacements & Calibration

※ The ASS'Y code can be changed, see "5 Chapter. Electrical Part List."

* Check items listed after changing each

Replaced Items	Code No.	Check Items
ASSY PCB MISC-MAIN	BN94-00933B	1) Auto Program 2) White Balance Adjust
ASSY PCB P-SMPS(MAIN)	BN96-03052A	Vs, Va voltage check and adjust
ASSY PCB P-SMPS(DC DC)	BN96-01856A	Vscan, Vset, Ve voltage check and adjust
ASSY PDP P-LOGIC BOARD	BN96-03106A	Not adjustment
ASSY PDP P-X MAIN BOARD	BN96-03101A	
ASSY PDP P-Y MAIN BOARD	BN96-03102A	
ASSY PDP P-Y MAIN SCAN BOARD	BN96-03103A	
ASSY PDP P-ADDRESS E BUFF BOARD	BN96-03104A	
ASSY PDP P-ADDRESS F BUFF BOARD	BN96-03105A	

※ When replacing the SMPS (DC DC) or PDP panel, you have to check the voltage printed on the panel sticker and adjust it.

3-6-1 Voltage Adjustment

1. After replacing the SMPS or PDP panel, you must adjust the voltage referring to the voltage label printed on the panel.
 (If you do not adjust the voltage, an abnormal discharge symptom may appear.)

	Value	Board Adjustment
Vs	200	SMPS-MAIN
Va	65	
Vset	195	SMPS-DC/DC
Ve	120	
Vscan	-190	

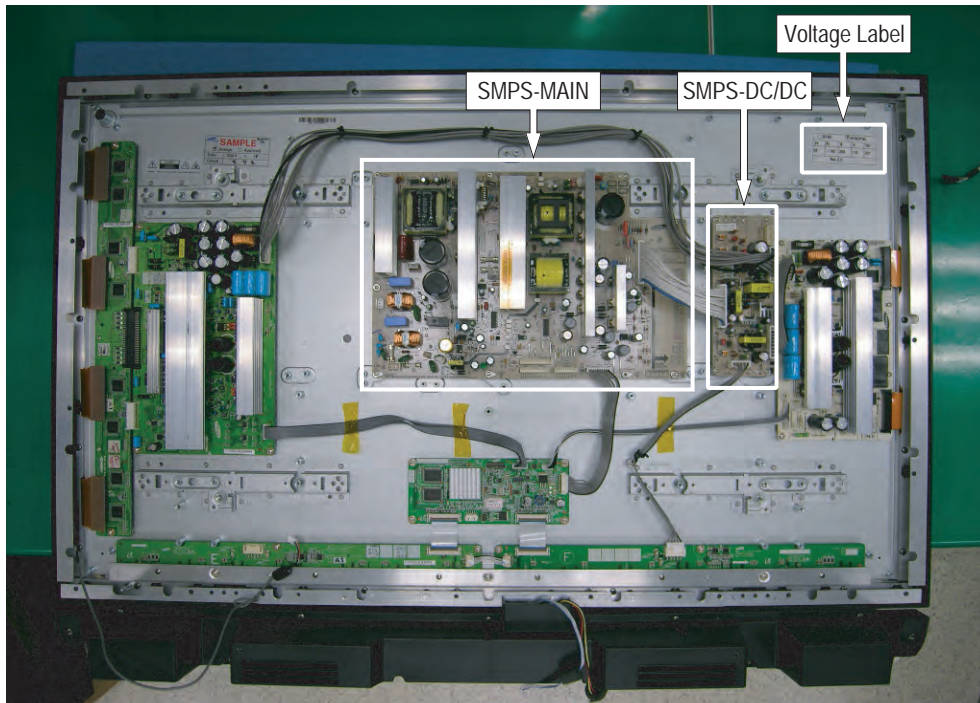

2. A point of adjusting SMPS-MAIN voltage.

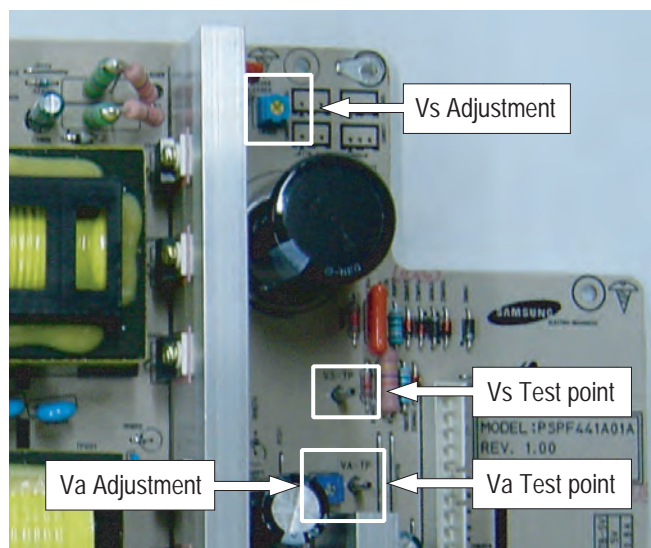

3. A point of adjusting SMPS-DC/DC.

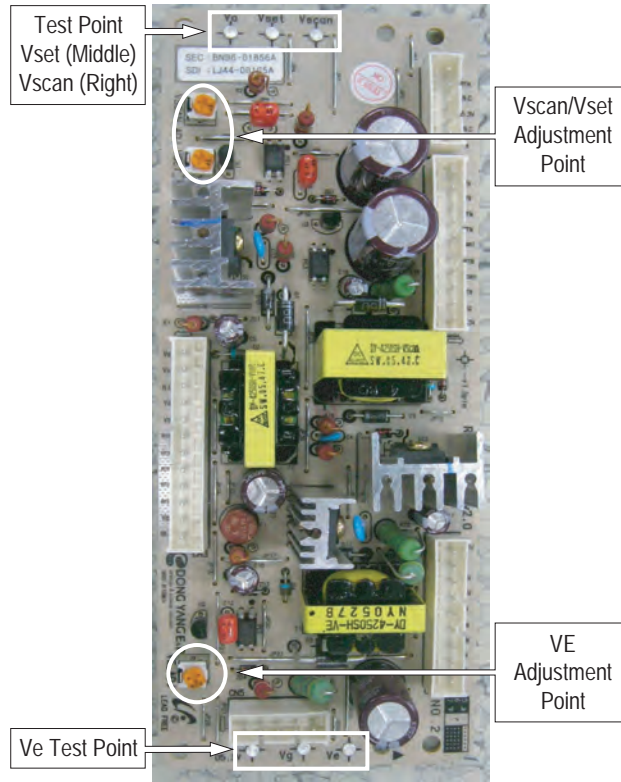

* Use base chassis of PDP panel as GND point.

1. Precaution

To avoid possible damages or electric shocks or exposure to radiation, follow the instructions below with regard to safety, installation, service and ESD.

1-1 Safety Precautions

1. Make sure all protective devices are properly installed including non-metallic handles and compartment covers when installing or re-installing the chassis or chassis assemblies.
2. Make sure that no gaps exist between the cabinets for children to insert their fingers in to prevent children from receiving electric shocks. Gaps mentioned above include ventilation holes of a too great magnitude between the PDP module and the cabinet mask, and the improper installation of the rear cabinet.

Errors may occur when the resistance is below 1.0 M Ω or over 5.2 M Ω .

In these cases, make sure that the device is repaired before sending it back to the customer.

3. Check for Electricity Leakage (Figure 1-1)
Warning: Do not use an insulated transformer for checking the leakage. Use only those current leakage testers or mirroring systems that comply with ANSIC 101.1 and the Underwriter Laboratory's specifications (UL1410, 59.7).

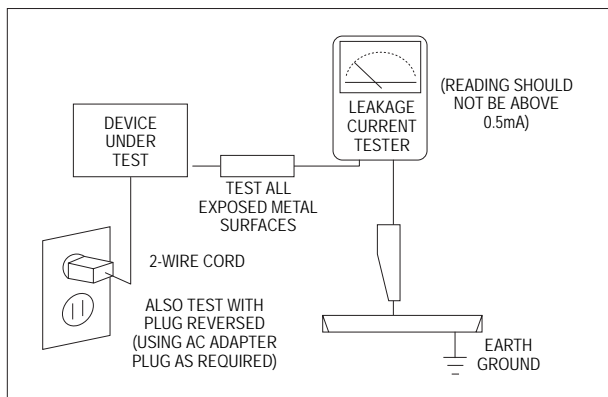

Fig. 1-1 AC Leakage Test

4. A high voltage is maintained within the specified limits using safety parts, calibration and tolerances. When voltage exceeds the specified limits, check each special part.

5. Warning for Engineering Changes:
Never make any changes or additions to the circuit design or the internal part for this product.
Ex: Do not add any audio or video accessory connectors. This might cause physical damage.
Furthermore, any changes or additions to the original design/engineering will invalidate the warranty.
6. Warning - Hot Chassis:
Some TV chassis are directly connected to one end of the AC power cord for electrical reasons.
Without insulated transformers, the product can only be repaired safely when the chassis is connected to the earthed end of the AC power source.



To make sure the AC power cord is properly connected, follow the instructions below. Use the voltmeter to measure the voltage between the chassis and the earthed ground. If the measurement is over 1.0V, unplug the AC power cord and change the polarity before re-inserting it. Measure the voltage between the chassis and the ground again.

7. Some TV chassis are shipped with an additional secondary grounding system. The secondary system is adjacent to the AC power line. These two grounding systems are separated in the circuit using an unbreakable/unchangeable insulation material.
8. When any parts, material or wiring appear overheated or damaged, replace them with new regular ones immediately. When any damage or overheating is detected, correct this immediately and make a regular check of possible errors.
9. Check for the original shape of the lead, especially that of the antenna wiring, any sharp edges, the AC power and the high voltage power. Carefully check if the wiring is too tight, incorrectly placed or loose. Never change the space between the part and the printed circuit board. Check the AC power cord for possible damages. Keep the part or the lead away from any heat-emitting materials.

Precaution

10. Safety Indication:

Some electrical circuits or device related materials require special attention to their safety features, which cannot be viewed by the naked eye. If an original part is replaced with another irregular one, the safety or protective features will be lost even if the new one has a higher voltage or more watts.

Critical safety parts should be bracketed with ( ). Use only regular parts for replacements (in particular, flame resistance and dielectric strength specifications). Irregular parts or materials may cause electric shock or fire.

1-2 Servicing Precautions

Warning 1: First carefully read the "Safety Instruction" in this service manual.

When there is a conflict between the service and the safety instructions, follow the safety instruction at all times.

Warning 2: Any electrolytic capacitor with the wrong polarity will explode.

1. The service instructions are printed on the cabinet, and should be followed by any service personnel.
2. Make sure to unplug the AC power cord from the power source before starting any repairs.
 - (a) Remove or re-install parts or assemblies.
 - (b) Disconnect the electric plug or connector, if any.
 - (c) Connect the test part in parallel with the electrolytic capacitor.
3. Some parts are placed at a higher position than the printed board. Insulated tubes or tapes are used for this purpose. The internal wiring is clamped using buckles to avoid contact with heat emitting parts. These parts are installed back to their original position.
4. After the repair, make sure to check if the screws, parts or cables are properly installed. Make sure no damage is caused to the repaired part and its surroundings.
5. Check for insulation between the blade of the AC plug and that of any conductive materials (i.e. the metal panel, input terminal, earphone jack, etc).
6. Insulation Check Process: Unplug the power cord from the AC source and turn the switch on. Connect the insulating resistance meter (500v) to the AC plug blade.
7. Any B+ interlock should not be damaged. If the metal heat sink is not properly installed, no connection to the AC power should be made.
8. Make sure the grounding lead of the tester is connected to the chassis ground before connecting to the positive lead. The ground lead of the tester should be removed last.
9. Beware of risks of any current leakage coming into contact with the high-capacity capacitor.
10. The sharp edges of the metal material may cause physical damage, so ensure wearing protective gloves during the repair.
11. Due to the nature of plasma display panels, partial after-images may appear if a still picture is displayed on the screen for a long period of time.
This is caused by brightness deterioration due to the storage effect of the panel, and to prevent this from happening, we recommend that the brightness and contrast are reduced.
(e.g.) Contrast: 25, Brightness: 50

The insulating resistance between the blade of the AC plug and that of the conductive material should be more than 1 M Ω .

1-3 Static Electricity Precautions

1. Some semi-conductive ("solid state") devices are vulnerable to static electricity. These devices are known as ESD. ESD includes the integrated circuit and the field effect transistor. To avoid any materials damage from electrostatic shock, follow the instructions described below.
2. Remove any static electricity from your body by connecting the earth ground before handling any semi-conductive parts or ass'ys. Alternatively, wear a dischargeable wrist-belt.
(Make sure to remove any static electricity before connecting the power source - this is a safety instruction for avoiding electric shock)
3. Remove the ESD ass'y and place it on a conductive surface such as aluminum foil to prevent accumulating static electricity.
4. Do not use any Freon-based chemicals. Such chemicals will generate static electricity that causes damage to the ESD.
5. Use only grounded-tip irons for soldering purposes.
6. Use only anti-static solder removal devices. Most solder removal devices do not support an anti-static feature. A solder removal device without an anti-static feature can store enough static electricity to cause damage to the ESD.
7. Do not remove the ESD from the protective box until the replacement is ready. Most ESD replacements are covered with lead, which will cause a short to the entire unit due to the conductive foam, aluminum foil or other conductive materials.
8. Remove the protective material from the ESD replacement lead immediately after connecting it to the chassis or circuit ass'y.
9. Take extreme caution in handling any uncovered ESD replacements. Actions such as brushing clothes or lifting your leg from the carpet floor can generate enough static electricity to damage the ESD.

CAUTION

These servicing instructions are for use by qualified service personnel only. To reduce the risk of electric shock do not perform any servicing other than that contained in the operating instructions unless you are qualified to do so.

1-4 Installation Precautions

1. For safety reasons, more than two people are required for carrying the product.

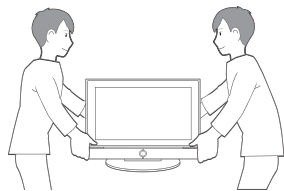

2. Keep the power cord away from any heat emitting devices, as a melted covering may cause fire or electric shock.
3. Do not place the product in areas with poor ventilation such as a bookshelf or closet. The increased internal temperature may cause fire.
4. Bend the external antenna cable when connecting it to the product. This is a measure to protect it from being exposed to moisture. Otherwise, it may cause a fire or electric shock.
5. Make sure to turn the power off and unplug the power cord from the outlet before repositioning the product. Also check the antenna cable or the external connectors if they are fully unplugged. Damage to the cord may cause fire or electric shock.
6. Keep the antenna far away from any high-voltage cables and install it firmly. Contact with the high-voltage cable or the antenna falling over may cause fire or electric shock.
7. When connecting the RF antenna, check for a DTV receiving system and install a separate DTV reception antenna for areas with no DTV signal.
8. When installing the product, leave enough space (4") between the product and the wall for ventilation purposes. A rise in temperature within the product may cause fire.
9. When moving a PDP with removable speakers, detach the speakers first before moving the main body. Moving the PDP main body without separating the speakers may cause the speakers to detach, possibly causing damage or injury.

MEMO

13. Circuit Description

13-1 Power ON/OFF Signal Timing Sequence

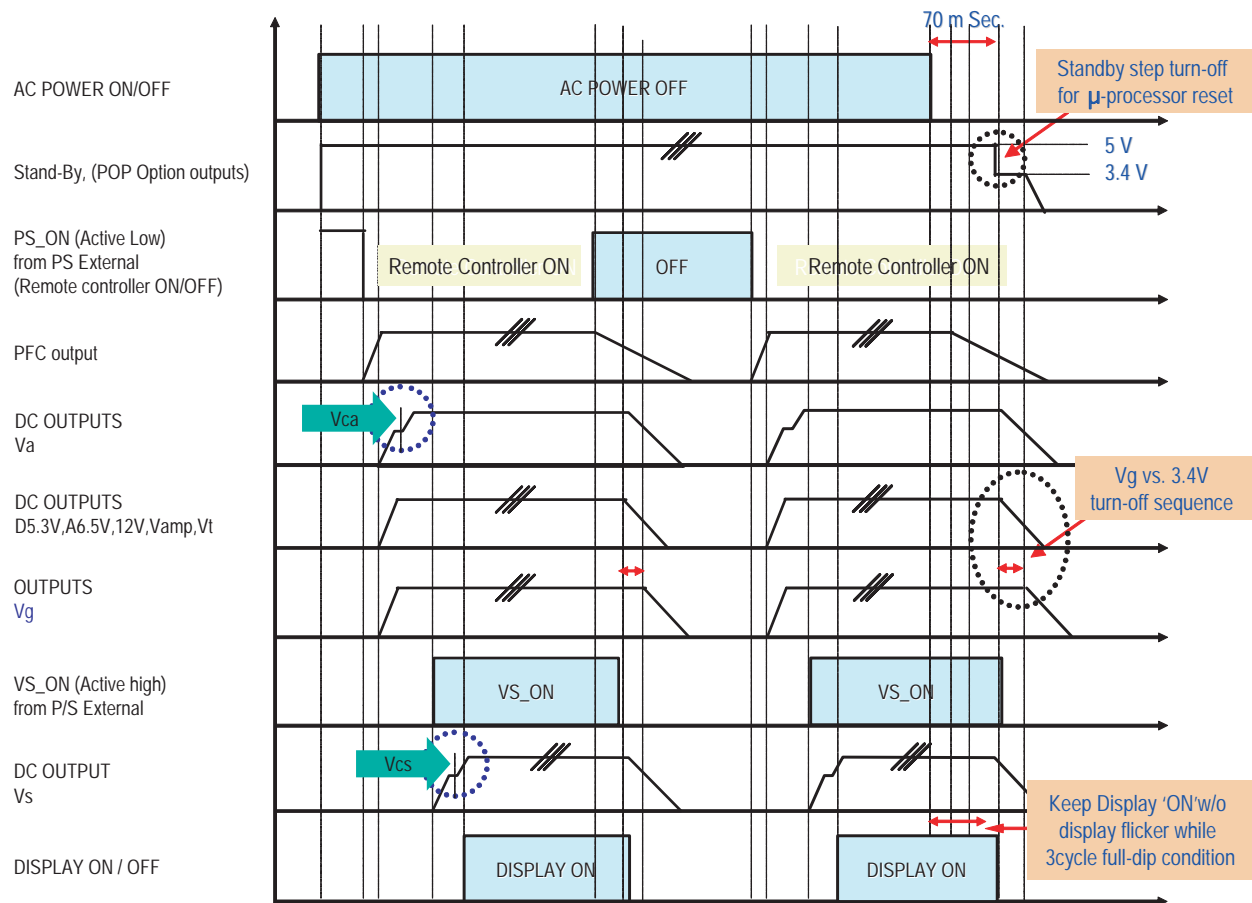

1. When connecting the AC power cord, Stand-By 5V from the Main SMPS is supplied to the Main Board (Pin 3 of CN1002 of Main Board).
2. When pressing the Power button on the remote control or on the main body, PS_ON (Pin 5 of CN1002 of Main Board) changes from High to Low.
3. If the PS_ON signal changes to Low, the Main SMPS supplies power to the Main Board and Logic Board, and Va and Vg power is supplied to the DC-DC SMPS.
4. If the VS_ON signal from the Logic Board changes from Low to High, the Main SMPS supplies VS power to the X and Y Main Board through the DC-DC SMPS, and the screen displays a picture on it.

13-2 Partial Block Description

13-2-1 Main SMPS

1. Outline (PDP 42inch/50inch SMPS)

Considering various related conditions, the switching regulator with good efficiency and allowing for its small size and light weight was used as the power supply for PDP 42inch/50inch, VS requiring high power consumption Asymmetrical Half Bridge converter and flyback converter. To comply with the international harmonics standards and improve the power factor, active PFC(Power Factor Correction) was used to rectify AC input into +400V DC output, which in turns used as input to the switching regulator.

2. Input

The power supply shall be capable of supplying full rated output power over free voltage ranges that are rated 100 VAC - 240 VAC RMS nominal. Operating voltage : 90 VAC - 264 VAC

The power supply must be able to start up under peak loading at 90V AC. The power supply shall automatically recover from AC power loss. (Note that nominal voltages for test purposes are considered to be with +/- 1.0V of nominal).

STD_5V & Vpr2(3.3V) is a SELV standby voltage that is always present when AC mains voltage present.

3. Output

Output Name	Output Voltage	Output Current(Max.)	Using in PDP Driving
VS	+190V ~ 220V (210V)	2.0A	Sustain Voltage of Drive Board
VA	+60V ~ 80V (70V)	3.0A	Address Voltage of Drive Board
D5.3V	+5.3V	5.0A	
A6.5V	+6.5V	3.0A	
FAN_9V	+9V	0.2A	
VG	+15V	1.0A	
D12V	+12V	1.5A	
A12V	+5.3V	0.5A	
18VAMP	+18V	2.5A	Amp Voltage of Audio Board
VT	+33V	0.006A	
STD_5V	+5V	1.0A	Standby for Remote Control

① Over Voltage Protection

The over voltage sense circuitry and reference shall reside in package that are separate and distinct from the regulator control circuitry and reference. No single point fault shall be able to cause a sustained over voltage condition on any of all outputs.

The supply shall provide latch-mode Over Voltage Protection as defined below.

Parameter	Min	Unit
VS(210V)	250 ~	V
VA(70V)	100 ~	V
VCC(+5.3V)	6.8 ~	V

② Short Circuit and Over current Protection

An output short circuit is defined as output impedance of less than 300mohms. The power supply shall shutdown and latch off for shorting VS DC rails to return. Shorts between main output rails and STD_5V shall not cause any damages to the power supply. The power supply shall either shutdown and latch off for shorting is removed, the P/S shall recover. The power supply shall be capable of withstanding a continuous short-circuit to the output without damage or over stress to the unit (components, PCB traces,connectors,etc.) under the input conditions specified in Section 3 above. Current Protection as defined below.

Output	Over Current Limit	Unit
VS(210V)	20A, Constant Current.(TBD)	A
VA(70V)	10A, Constant Current.(TBD)	A
Output except Vs,Va	No damage (Auto Recovery or Shut down.)	A

13-2-2 PDP Module

1. Logic Board

■ A name of main part of Logic Board and vocabulary.

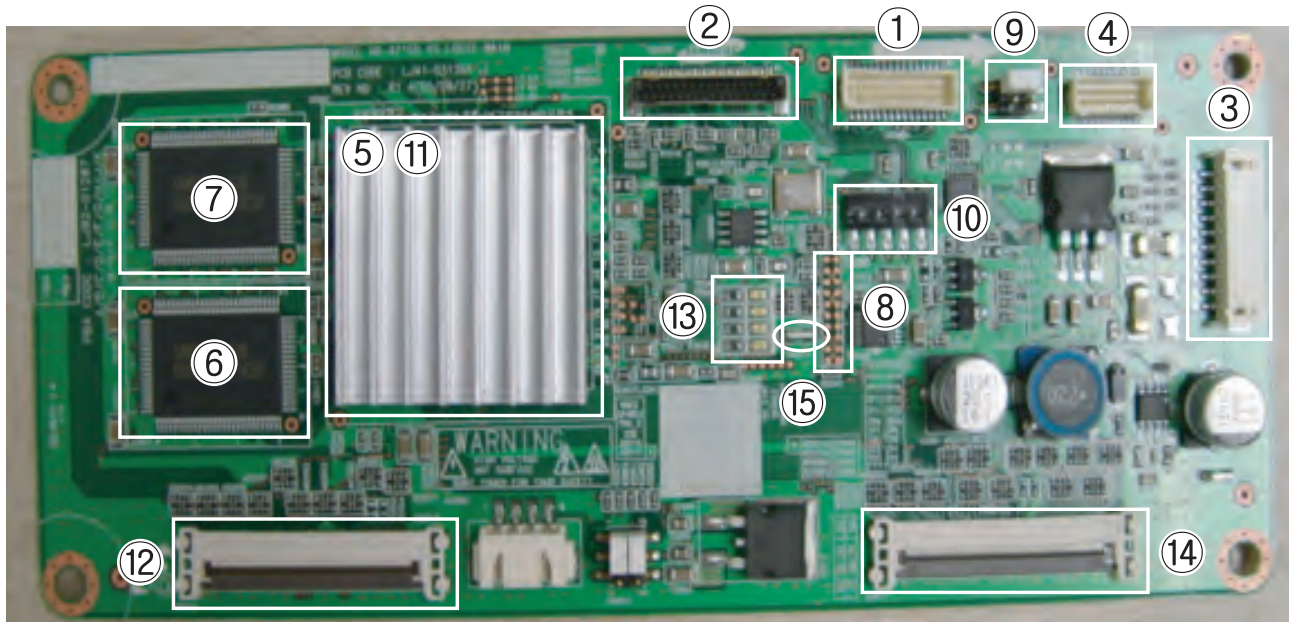

Item	Name	Explanation												
①	Y Connector	The connector to output the control signal for the Y drive board.												
②	LVDS Connector	The connector to receive the RGB, H, V, DATAEN and DCLK signals that have been LVDS encoded through the video board.												
③	Power Connector	The connector to receive power (5V, 3.3V) for the Logic board.												
④	X Connector	The connector to output the control signal for the X drive board.												
⑤	ASIC CHIP	The main processor that generates and outputs the logic drive signal and the address data.												
⑥	DDR MEMORY (MENCON)	The Memory to restore Address output data.												
⑦	DDR MEMORY (Frame Delay)	The Memory to restore FCR data.												
⑧	JTAG PORT	The port to communicate uCOM.												
⑨	Initial image option PIN	Initial image select F/W or BLACK : Jumper Yes : <table border="1" style="display: inline-table; vertical-align: middle;"><tr><td>4</td><td>3</td></tr><tr><td>2</td><td>1</td></tr></table> or <table border="1" style="display: inline-table; vertical-align: middle;"><tr><td>4</td><td>3</td></tr><tr><td>2</td><td>1</td></tr></table> Full White, Jumper No : <table border="1" style="display: inline-table; vertical-align: middle;"><tr><td>4</td><td>3</td></tr><tr><td>2</td><td>1</td></tr></table> Black	4	3	2	1	4	3	2	1	4	3	2	1
4	3													
2	1													
4	3													
2	1													
4	3													
2	1													
⑩	Micom Loading 5Pin Connector or Uart Connector	The connector to load the Micom drive program. The program is loaded by connecting to the GA-WRITER. Connector that loads and controls 512K data, and connects kiss can Board												
⑪	ARM-PROCESSOR	IC block Control-signal to drive logic main.												
⑫	Buffer Connector	The connector to output the address data and the control signal to the E-buffer board.												
⑬	Operating Status LED	The LED that shows whether the Sync and Clock signal is properly supplied to the logic board. (Normal Status: Blinks at 0.5 second intervals)												
⑭	Buffer Connector	The connector to output the address data and the control signal to the F-buffer board.												
⑮	V-TOGG	V-SYNC output pin.												

■ About Logic Board

The Logic Board consists of a Logic Main board, which processes the video signal input through LVDS and creates the address driver output and XY drive signals, and a Buffer board, which buffers the output signal and outputs the signal to the Address Driver IC (TCP IC).

Logic Board		Function	Remark
Logic Main		- Video Signal Processing (W/L, error diffusion, APC, FCR) Built-in LVDS Application and 1 ASIC Chip - Outputs the Address Driver Control and Data Signals to the Buffer board - Outputs the XY Drive Board Control Signal - Major Drive Voltage Monitoring (MICOM Circuit Block) : Detects abnormal voltage applications and protects drive circuits - Temperature Induced Operating Mode (Low Temperature/Room Temperature/High Temperature) : Optimization of discharge by temperature	
Buffer Board	E Buffer Board	Outputs data and control signals to the bottom left TCP IC.	Single Scan
	F Buffer Board	Outputs data and control signals to the bottom right TCP IC.	

■ Normal Waveform

When the Operating LED blinks normally (at 0.5 second intervals), which indicates the normal operation of the PDP Set and Logic Board, and the V-SYNC and data output signals are normal.

If the set is out of order, perform troubleshooting according to the procedures below.

- 1) Visual Inspection : Check if the Operating LED on the Logic Main blinks at a 0.5 second interval.
 - ▶ If the Operating LED blinks too fast or too slow, you have to reload the data onto the MICOM, as this indicates abnormal data processing in the MICOM. To load the data, supply power to the module and load the data using GA-WRITER.
- 2) If no problem has been found through the visual inspection, check if the drive waveforms and the address data output are normal. (Check Point: Check the DAMPING R-NET output of each data output terminal.)
 - ▶ If no drive waveform or address output signal is detected, load data onto the MICOM according to the procedures described above, as this indicates a MICOM data error.
 - ▶ If data output is detected but is abnormal, it indicates a hardware short-circuit if measured for the drive waveform, or it indicates abnormal data output due to the abnormal operation of the DDR memory caused by the abnormal Vref voltage if measured in the address data. Abnormal data output due to the abnormal operation of the DDR memory or a short circuit on the board, which may be caused during the ass'y process, causes the screen to be abnormally displayed. Therefore, you have to conduct a short test for each part.
 - ▶ If the Vref voltage (Voltage Divider Voltage) is lower than 1.25V, check the resistance of the resistance output part and check if the circuit status is normal. This applies the voltage and the proper Vref voltage and results in the screen being properly displayed.
 - ▶ If the screen is abnormally displayed, even though the Vref voltage is normal, find any abnormal points by conducting a short test. If a short circuit is found and it is repairable, repair it. If a short circuit is internal, replace the board.
 - ▶ The following waveform appears when the V-sync and address data are output properly.

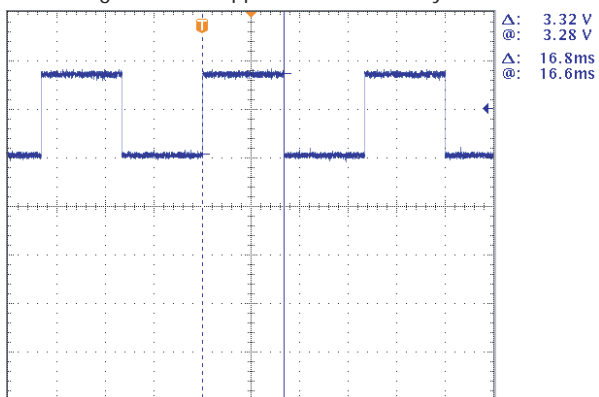

< Normal V-SYNC Output Waveform >

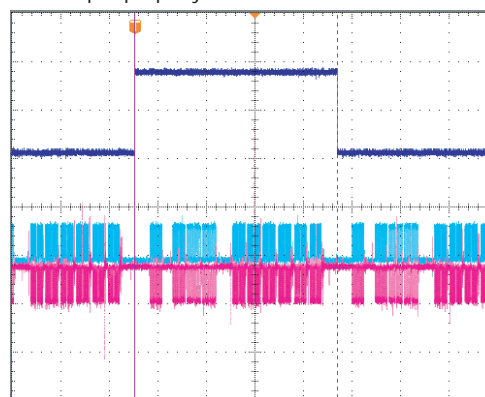

< Normal Address Data Output Waveform >

2. X, Y Control Block

■ Drive Circuit Definition

The Drive Circuit is a circuit that generates a waveform (high-voltage pulse) for the X and Y electrode group of the panel's external port so as to control the panel. The high-voltage switching pulse is generated through the combination of the IC HYBRID (Drive block + IGBT) and FET.

■ Drive Circuit Mechanism

A picture is displayed on the PDP by applying voltage to the X, Y and ADDRESS electrodes of each pixel according to the appropriate condition. The drive waveform applied to 42HD V4 is of the ISSS (ISSS: Interweaving Scan and Selective Sustain with Scan IC) type and has IDS (InDependent Sustain) in the Scan section unlike the existing ADS. Discharges within a PDP pixel can be classified into 3 types:

- ① Address Discharge: To form a wall voltage within the pixel by giving information (applying DATA voltage) to the pixel to be lit.
- ② Sustain Discharge: Sustain Discharge is a display section that voluntarily maintains the discharge of the pixels whose wall voltage has been formed by the Address Discharge. (Optical output for displaying a picture is generated).
- ③ Erase Discharge: To selectively perform Address Discharge for each pixel, all pixels on the panel should be in the same status (the wall electric charge status and space electric charge status must be the same). Therefore, the Erase Discharge section is an important component for guaranteeing the drive margin, and is implemented by various methods such as applying a log waveform. However, the current 42HD V4 has adopted a wall voltage control through an RA (Repeated Auto-quenching) reset that separates the discharge area and performs switching to perform an efficient erase operation, while the gradient was the same in the RAMP section in the existing approach.

1) Address Discharge

A discharge that is caused by the difference between the plus electric potential (V_a apply voltage of 65-70V + Positive Wall Charge) of the electrode and the negative electric potential (Applied GND Level + Negative Wall Charge) of the Y electrode. The Address discharge forms a wall voltage within the pixel to display color (to be discharged) before the Sustain Discharge period. That is, the pixel whose wall charge has been formed by the Address Discharge forms a Sustain Discharge via the following Sustain pulse.

2) Sustain Discharge

A Sustain Discharge is a Self-Sustaining Discharge formed by the accumulation of the electric potential of the Sustain pulse (generally 200 ~ 210 Volt) alternating over the X and Y electrodes during the sustain period, and the wall charge depending on whether the pixel has previously been discharged or not. That is, it is controlled by the memory characteristics, one of the basic characteristics of the AC PDP (in that the past operating conditions determine the current status). That is, if a wall voltage exists on the pixel (if the pixel is on), a discharge is formed again because the applied voltage, which is the sum of the following applied Sustain voltage and the wall voltage, is higher than the discharge threshold voltage. If no wall voltage exists on the pixel (if the pixel is off), a discharge will not occur because the Sustain voltage is not higher than the discharge threshold voltage. The Sustain Discharge period is the period for generating actual optical output so as to display a picture on the PDP screen.

3) Erase Discharge

The purpose of a Reset (Erase) Discharge is to create uniformity of the wall voltage within all panel pixels. It evens the wall voltages regardless of the Sustain Discharge in the previous stage. The Erase Discharge has to remove the wall voltage introduced by the Sustain Discharge by supplying ions or electrons by a discharge. When the wall voltage is removed through a discharge, the time when the reverse polarity is applied to the wall voltage (fine width erasing) is to be limited or ions or electrons are to be supplied by a weak discharge (low voltage erasing) so as to prevent a wall charge in reverse polarity.

There are 2 known weak discharge (low-voltage) erase methods. 1) A log waveform adopted by F company and 2) a weak erase discharge via a ramp waveform adopted by Matsushita and other companies. Both methods control the externally applied voltage by the difference of the wall voltage of the pixel by applying the rising gradient of the erasing waveform slowly, because the discharge begins when the sum of the existing remaining wall voltage and the rising waveform voltage exceeds the drive threshold voltage. In addition, a weak discharge is introduced, because the applied voltage is low.

■ Requisite Components Necessary for Drive Board Operation

1) Power

- Supplied from the power board. The optimal value may differ from the following:
 - a) V_s : 200V - Sustain
 - b) V_{set} : 190V - Y Rising Ramp
 - c) V_e : 110V - V_e bias
 - d) V_{scan} : -190V - Scan low bias
 - e) V_{sc_h} : -70V - Scan high bias (Created by the DC-DC power block of the Y Drive board)
 - f) V_{dd} : 5V - Logic signal buffer IC
 - g) V_{cc} : 15V - Gate drive IC

2) Logic Signal

- Supplied by the Logic board
- Gate signal of each switch

■ Drive Circuit Architecture and Function Description

- Description of the function of each board

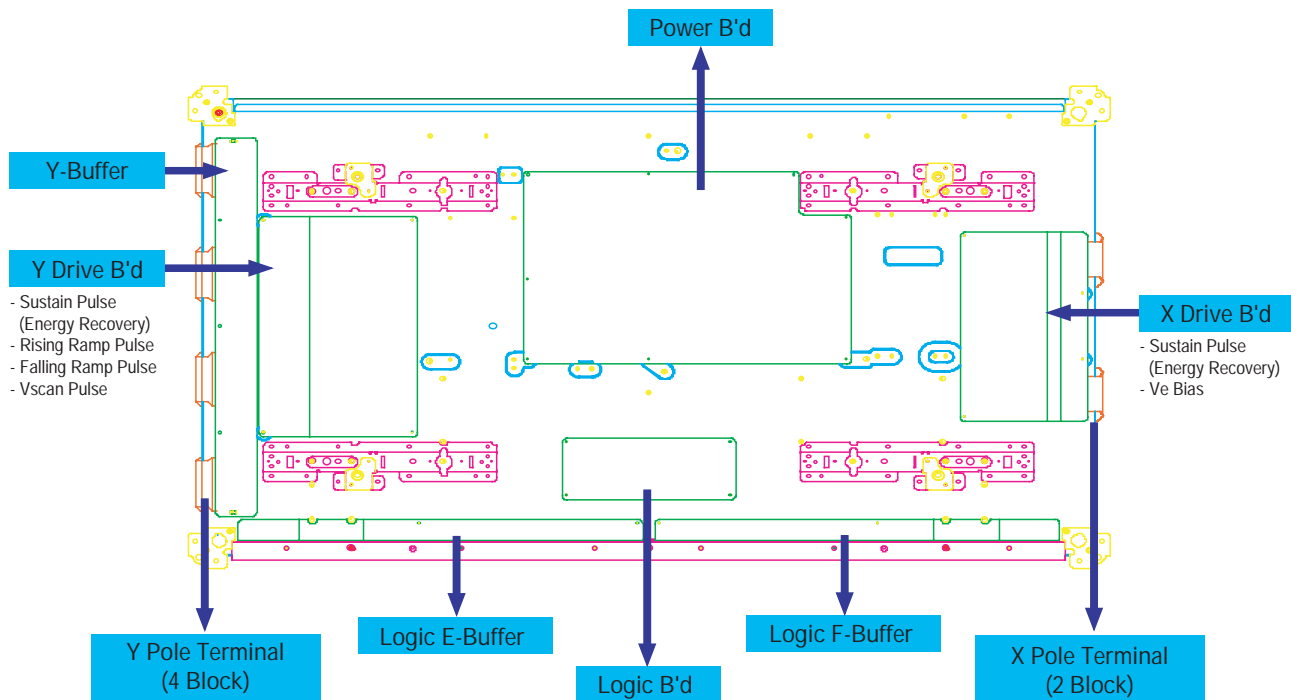

1) X Drive Board

This is connected to the X port part of the panel. 1) Sustain voltage waveform (including ERC) is output, and 2) V_e bias in the Scan section is maintained.

2) Y Drive Board

This is connected to the Y port part of the panel. It outputs 1) Sustain voltage wave form (including ERC), and 2) Y Rising, Falling Ramp waveform, and maintains 3) V_{scan} bias.

3) Y Buffer Board

A board, which applies the Scan waveform to the Y terminal block, consists of 12 Scan Driver ICs (TI SN755870: 64 Outputs).

■ Drive Waveform Specifications

- Drive Waveform

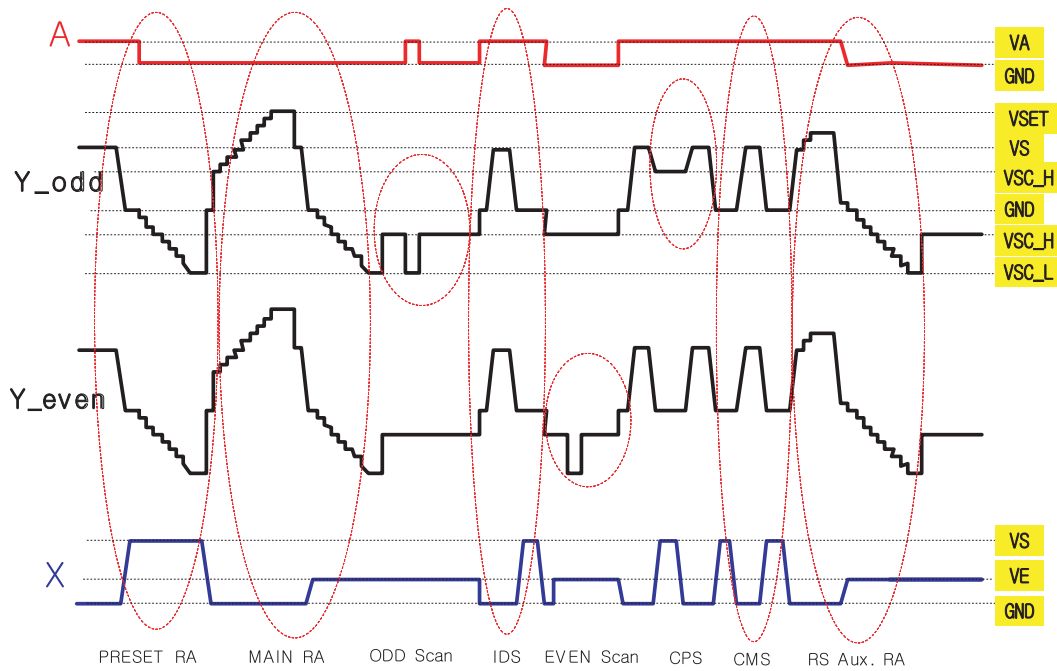

- Description of the function of each pulse

1) Y Preset RA Pulse

This is supplied to the first sub-field and erases the discharge status of the previous subfield.

2) Y Main RA Pulse

During the Y Rising Ramp section, approximately 300V~350V ($V_{scan-h} + V_{set}$) of external voltage is supplied to the Y electrode, and a weak discharge is started when each gap voltage is equal to the discharge start voltage. While maintaining the weak discharge, as a whole, negative wall charges are accumulated on the Y electrode and positive wall charges on the X electrode and the address electrode.

During the Y Falling Ramp section, the negative wall charges accumulated on the Y electrode by the approximately 105V of X bias are used to erase the positive wall charges on the X electrode, and the address electrode maintains most of the positive wall charges accumulated during the (0V) Rising Ramp section preparing for the next address discharge.

3) Y Scan Pulse (Odd/Even)

A scan pulse classifies the Y electrode into Odd and Even lines and selects FPC output electrodes sequentially (one line-at-a-time). At this time, V_{scan} is called the Scan Bias Voltage.

A V_{scan} voltage of approximately -175 Volt (V_{sc-1}) is supplied to the electrode lines. For the other lines, -56 volt (V_{sc-h} is higher than V_{sc-l} by 120V) is supplied. However, negative wall charges are accumulated on the Y electrode by the Ramp pulse, and positive wall charges are accumulated on the address electrode, and the voltage applied to the cells, to which the Address pulse (70V~75V) has been applied, becomes higher than the discharge voltage. An address Discharge occurs as a result. Since the Scan and Data pulse is applied one line at a time as above, the address time of PDP is very long.

4) IDS Pulse (InDependent Sustain Pulse)

Since an Odd Scan is performed first, the Odd line output sustains optical twice during the IDS section. At this time, a Sustain Discharge does not occur for the Even line because the Even line is not scanned.

5) CPS Pulse (ComPare Sustain Pulse)

By floating the Odd line that caused the Sustain Discharge in the IDS section to the V_{scan-h} level, and introducing the Sustain Discharge only for Even lines, it compensates for the optical output difference between the Even and Odd lines.

6) CMS Pulse (ComMon Sustain Pulse)

Actual optical is output during the common Sustain Discharge section.

■ Mechanism of the FET Operation and High-Voltage Switching

Mechanism of the FET Operation

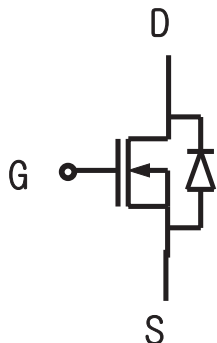

G : Gate
S : Source
D : Drain

- 1) When the signal is output to the gate, (positive electric potential) FET short circuits (i.e. Conductor of resistance 0)
- 2) When no signal is output to the gate (GND), FET changes to an open circuit (i.e. an insulator of resistance ∞).

High-Voltage Switching of the FET Operation

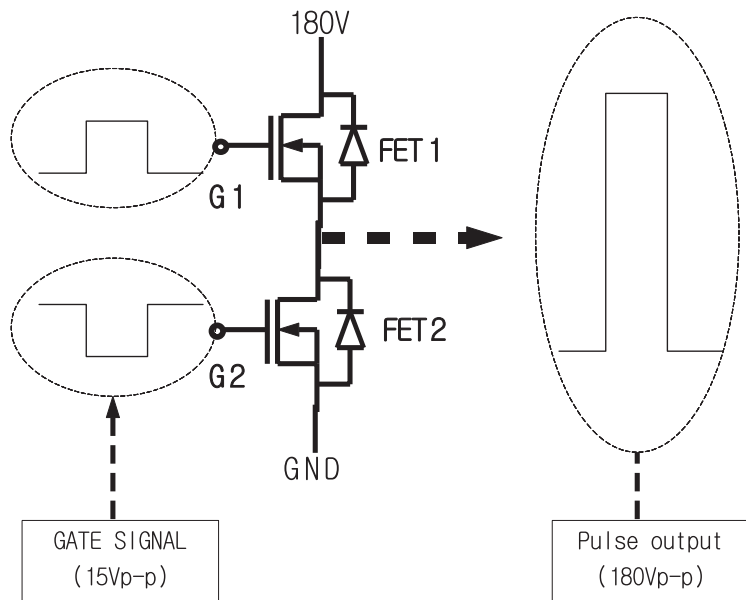

- 1) When no signal is applied to G1, FET1 is opened and when the signal is applied to G2, FET2 short circuits, GND is output via the output terminal.
- 2) When a signal is applied to G1, FET1 short circuits and when no signal is applied to G2, FET2 is opened, and 180V is output via the output terminal.

■ Drive Board Connector Layout
1) X-Main Board

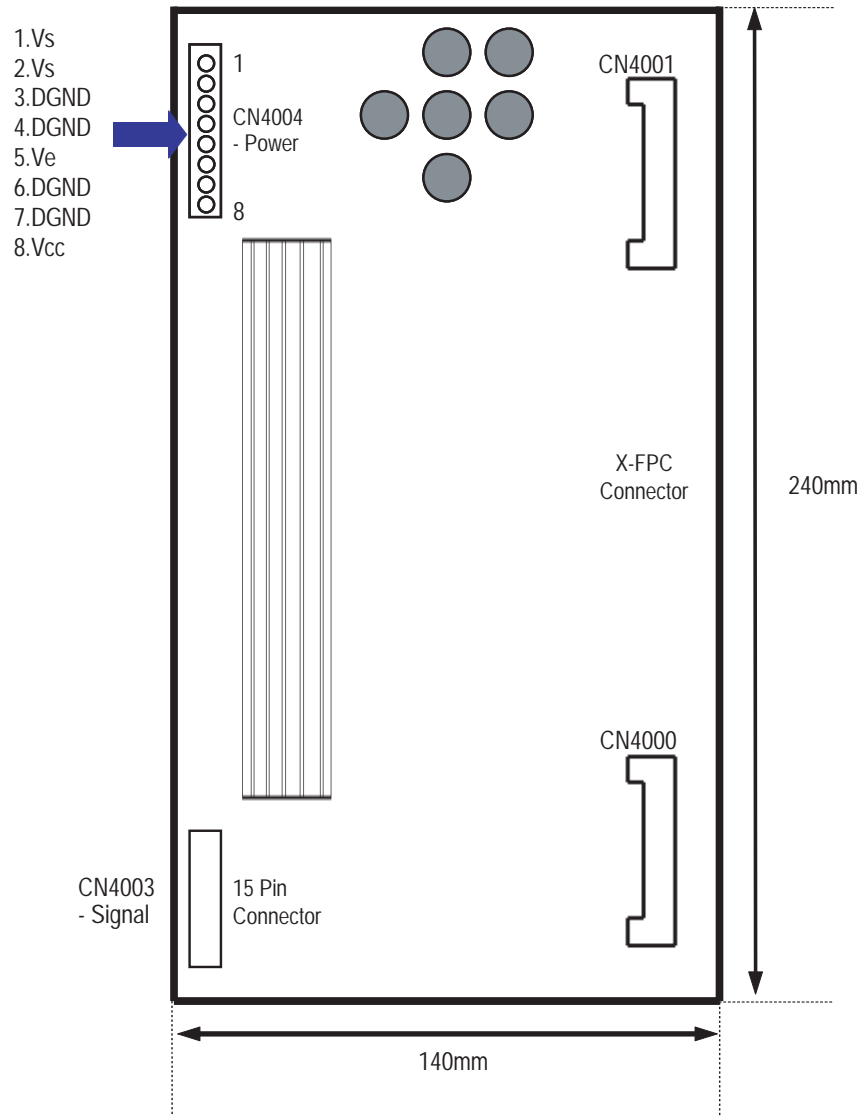

2) Y-Main Board

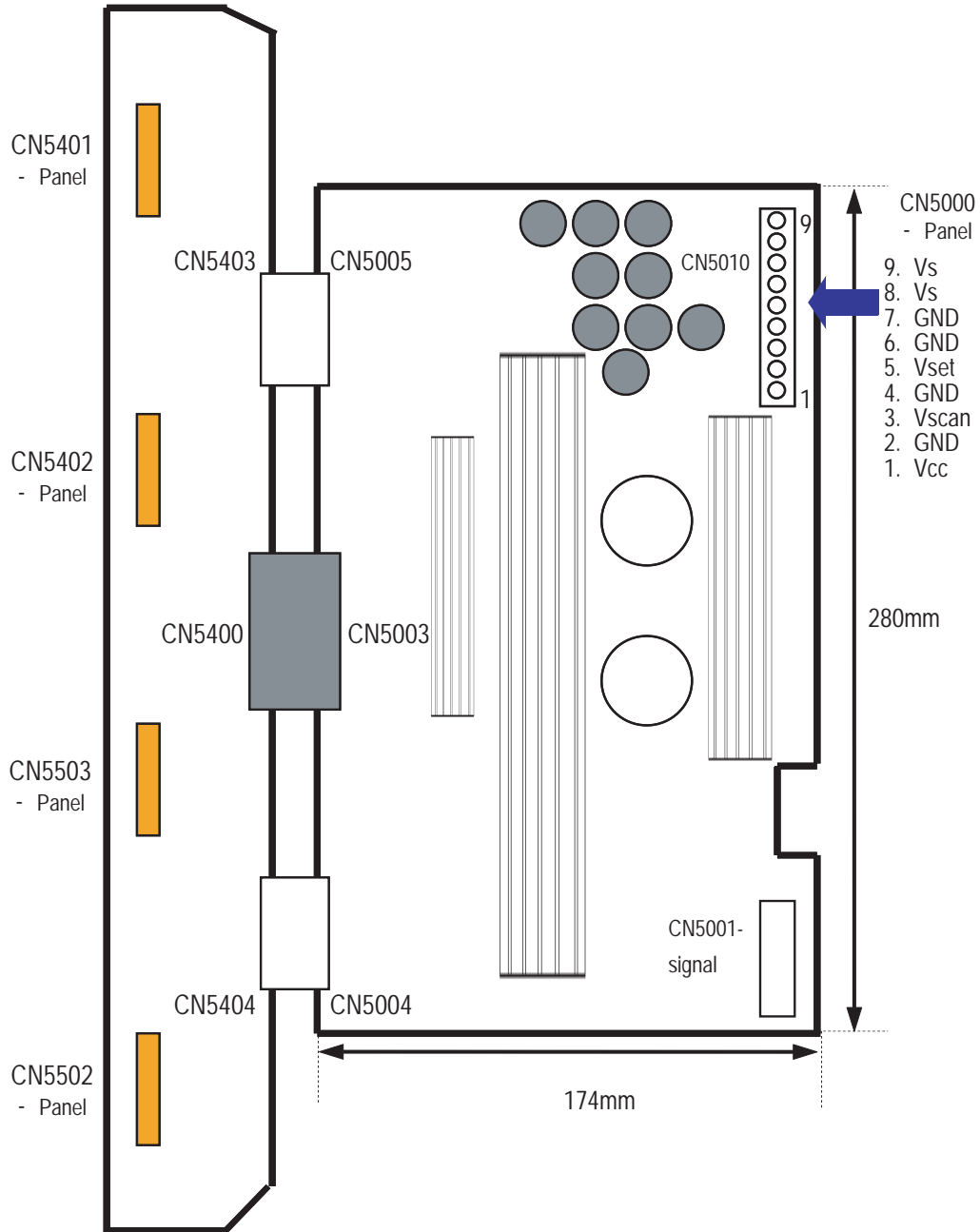

- ▶ Adjust the drive waveform so that the main reset (rising, falling:40usec) is the same as those in the F/W pattern.
(※ Attachment 1 reference)

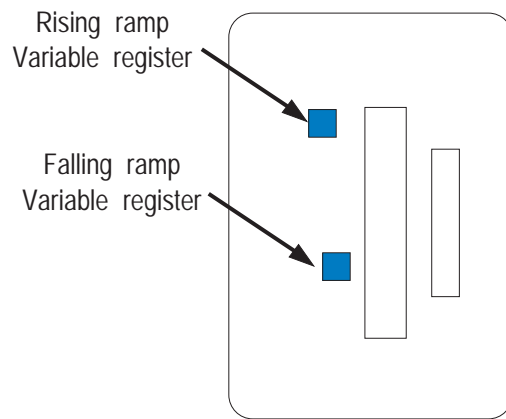
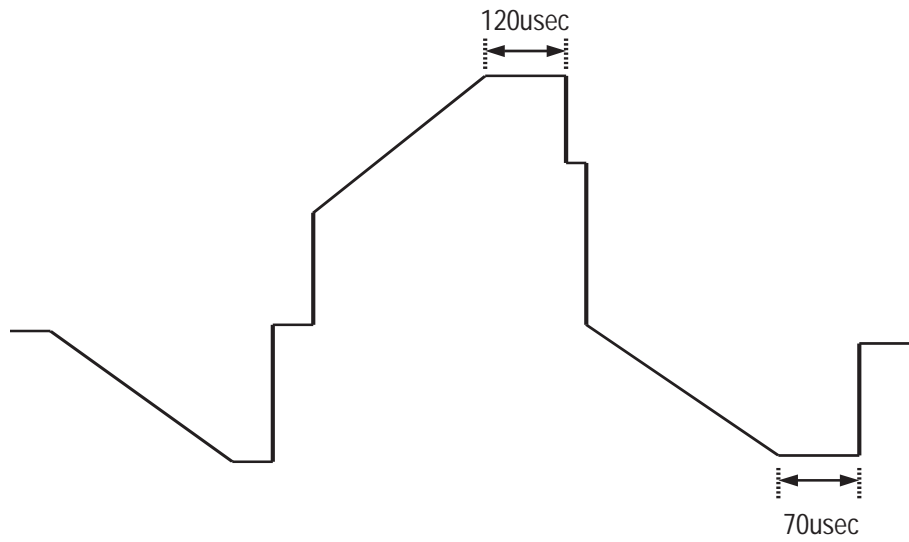

< Y-Main >

<Voltage Adjustment Specifications>

Vset	Vs	Vsc_l	Vsc_h	Ve	Va
201V	207V	-190V	-120V	110V	65V

- ▶ Check that the output of X-Out of the X board follows the waveform of ※ Attachment 2 when the power is supplied.

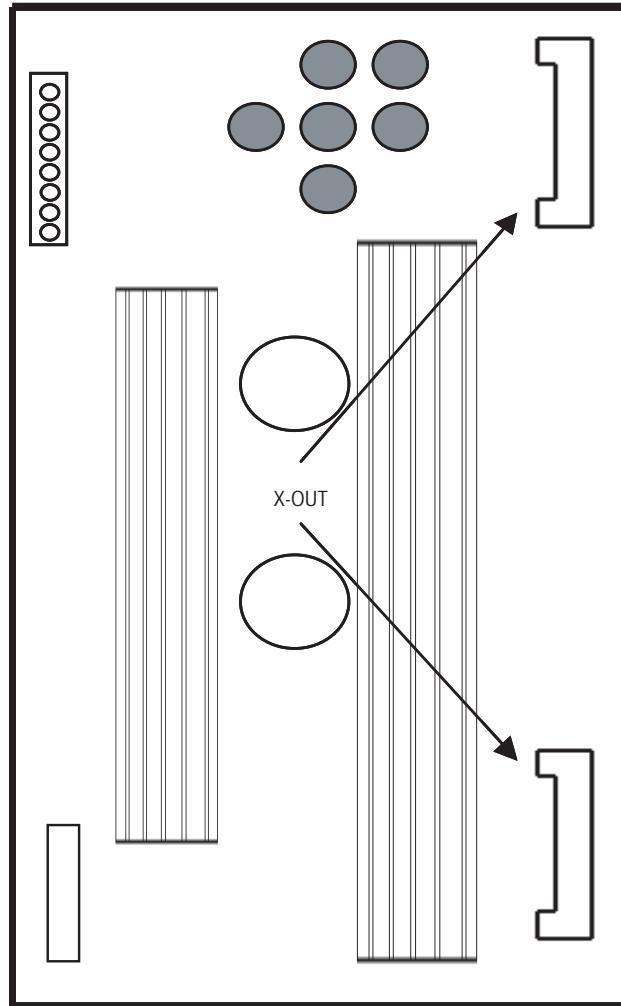

※ Attachment 1

■ Y Output Waveform

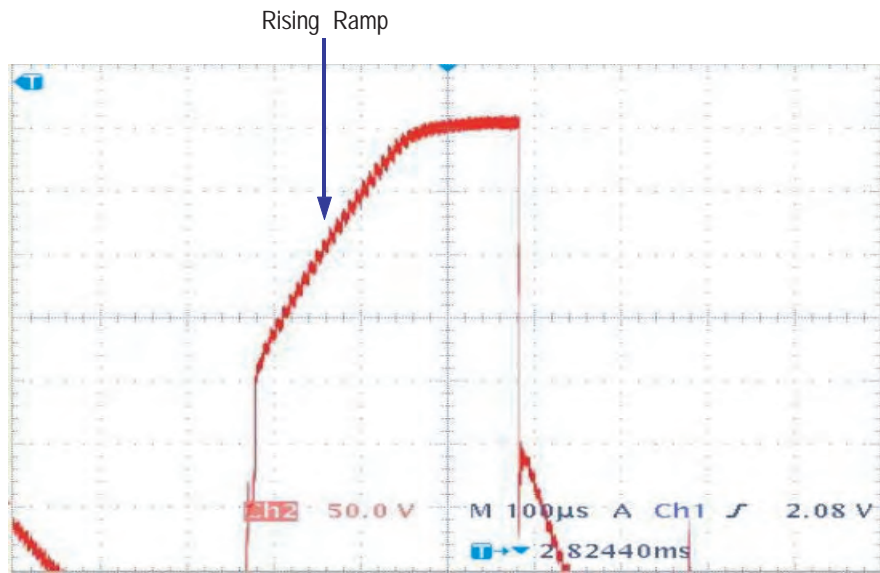

< Rising Ramp >

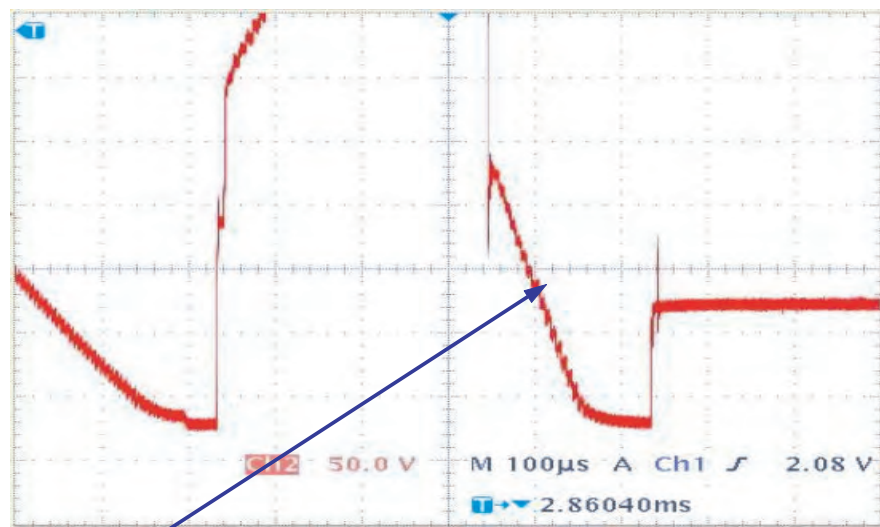

Falling Ramp

< Falling Ramp >

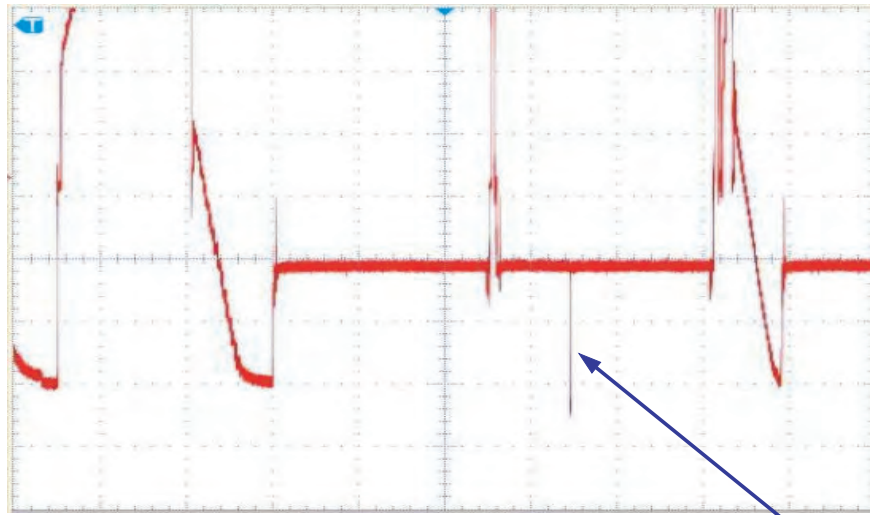

< Even_Scan >

Scan_I

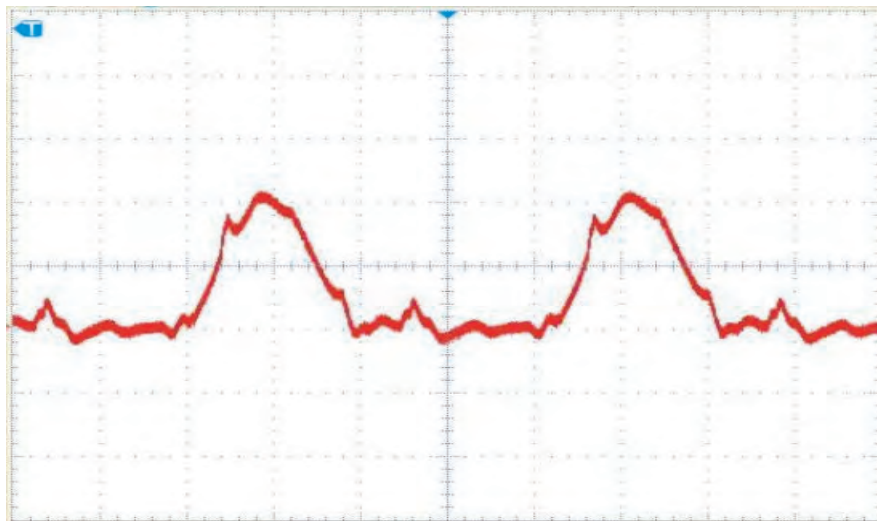

< Y Sustain >

Circuit Description

※ Attachment 2

■ X Output Waveform

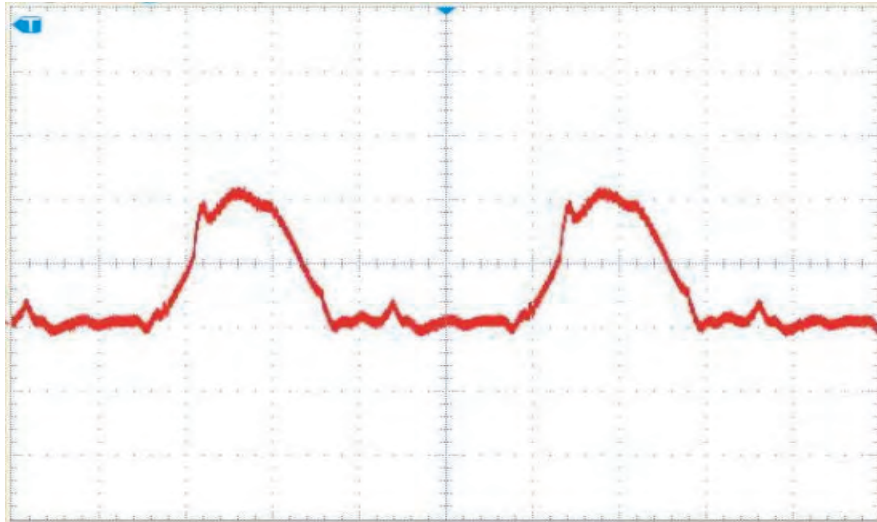

< X Sustain >

2. Product Specification

2-1 Product Features

Block	Specification	Major IC	Remark
RF	Tuner	TCPS3001PD32S(H)	SEMCO
Power	Input Voltage : AC 220 - 240V~, 50Hz		
Video	Scaler	SVP-PX	TRIDENT
	Video Decoder		
Sound	Sound Processor	STV8257DSX	ST Microelectronics
	Sound AMP	STA323W	ST Microelectronics
	Audio S/W	MM74HC4052	
PDP Module	Samsung SDI V5	42" SD	SAMSUNG SDI
Remocon	TM86		
Cabinet	E7		

■ Chip Description

- SVP-PX (IC611) : SVPTMPX contains dual-purposed triple 10-bit high-precision and high speed video ADCs for both PC and video inputs, the high speed HDMI could support all HDMI inputs up to 135MHz with HDCP format, the high-performance multi-format 3D digital comb video decoder that supports NTSC, PAL, and SECAM*, a HDTV sync separator, motion adaptive de-interlacing engine, and the video format conversion engine, supporting multi-window display in many different output modes.
- STV8257DSX (IC503) : Digital Audio Decoder/Processor
- STA323W (IC505) : Audio power amplifiers

2-2 Key Features

Model	PS-42E7S
Screen Size	107 Cm / 42 Inches (16:9)
Dimensions	1059.5(W) x 363(D) x 749.5(H) mm
Weight	35.0 Kg
Voltage	EU : AC 220-240V~, 50Hz CIS : AC 100-240V~, 50/60Hz
Colour System	PAL, SECAM, NT3.58, NT4.43
Sound System	BG, DK, I, L
Number of Pixels	852(H) X 480(V)
ANTENNA input	VHF, UHF (75Ω unbalanced)
VIDEO input	SCART1, SCART2 AV (Side), S-VIDEO (Side) 2 COMPONENT IN (480i/P, 576i/P, 720P, 1080i) PC IN (MINI D-SUB 15P) HDMI/DVI IN
AUDIO input	SCART1, SCART2 AV (Side), S-VIDEO (Side) 2 Component PC DVI
Audio Output	AUDIO OUT Headphone (Side)
Speaker Output	10W + 10W (8Ω)

■ H/W Configuration

- Video : SVP-PX
- Sound : STA8257DSX, STA323W
- Tuner : TCLW3001PD32S (H)

■ S/W Configuration

- Main Micom : M30840SGP (IC202)
- Sub Micom : 3F866BXZZ (IC207)

■ Picture

- System : Video → PAL/SECAM/NTSC4.43, Sound → Analog
- Progressive
- Output resolution : 852*480
- OSD : Smart user Interface
- Picture Enhancement : FBE
- Still picture, Noise reduction
- Comb Filter : 3D comb filter
- PIP : Large
- Panorama : Wide

■ Sound

- System : Stereo
- Output : 10W + 10W
- Speaker : built-in

■ Feature

- Component Interface (480i/480p/576i/576p/720p/1080i, Y/Pb/Pr)
- Digital Interface : HDMI
- Picture Size : Auto Wide/16:9/Wide4:3/Zoom/4:3
- Auto Store
- Sleep Timer : 180 minute
- Clock
- Zoom, Previous channel, Blue Screen, Color Tone, Screen Burn Protection

■ Remocon

- TM86

■ Power Supply

- EU : AC 220-240V, 50Hz
- CIS : AC 100-240V~, 50/60Hz

■ Power Consumption

- Max Power : 310 W



■ Both screen position and size will vary depending on the type of PC monitor and its resolution.

The table below shows all of the display modes that are supported. (N : Negative, P : Positive)











Video Signal	Resolution (Dot X Line)	Vertical frequency (Hz)	Horizontal frequency (kHz)	Vertical polarity	Horizontal polarity
IBM PC / AT Compatible	640 X 350	70.086	31.469	P	N
	720 X 400	70.087	31.469	N	P
	640 X 480	59.940	31.469	N	N
		70.000	35.000	N/P	N/P
		72.809	37.861	N	N
		75.000	37.500	N	N
	800 X 600	56.250	35.156	N/P	N/P
		60.317	37.879	P	P
		70.000	43.750	N/P	N/P
		72.188	48.077	P	P
		75.000	46.875	P	P
	848 X 480	60.000	31.020	P	P
		74.769	37.684	P	N
	1024 X 768	60.004	48.363	N	N
		70.069	56.476	N	N
		72.000	57.672	N/P	N/P
		75.029	60.023	P	P

- ▶ The interlace mode is not supported.
- ▶ The television might operate abnormally if a non-standard video format is selected.
- ▶ 480i/p, 576i/p, 720p, or 1080i is not available in PC mode.
- ▶ The PC text quality is optimum in WVGA mode (848 x 480@60Hz).

2-3 Specifications Analysis

Model		PS-42E7S (Audi-42SD)	Puccini(V4)
Design			
Basic	Display Type	PDP TV	PDP TV
	Built-In Tuner	O	O
	Resolution	852 x 480	1024 x 768
	PDP Module	V5	V4
	Screen Size	42 inches	42 inches
	Aspect Ratio	16 : 9	16 : 9
	Power Consumption	310 W	380 W
	Dimensions	1059.5(W) x 363(D) x 749.5(H) mm	1050(W) x 86(D) x 755(H) mm
Picture	Weight	35.0 Kg	59.2 Kg
	Brightness	1,100 Cd/m2	1,300 Cd/m2
	Contrast Ratio	5000:1	10,000 : 1
Audio	Image Enhancer	FBE	DNie-L
	Equalizer	O	O
	Auto Volume	O	O
	Surround Sound	SRS TruSurround	SRS TruSurround
	Speaker Output	10 W + 10 W	15 W + 15 W
Features	Speaker	Included	Included
	PIP	O	O
	Double Screen	X	O
	TTX	O	O
	Still Image	O	O
	My Color Control	X	O
	Color Weakness	X	O
	Energy Saving	O	O
Connections	Screen Burn Protection	O	O
	Antenna	1 Input	1 Input
	CVBS	2 AV	1AV
	S-Video	1 Input	1 Input
	Component(Y/PB/PR)	2 Input	1 Input
	PC(D-SUB)	1 Input	1 Input
	DVI	X	X
	HDMI	1 Input	1 Input
	Sub Woofer	X	X
Optical	X	X	
Coaxial	X	X	

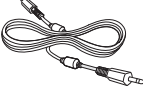
2-4 Accessories

Accessories	Item	Item code	Remark	
Supplied Accessories		User Manual	BN68-00989T	Samsung Service center
		Remote Control AAA Batteries	BN59-00531A 4301-000103	
		Power Cord	3903-000145	
		Core Ferrite	3301-001110	
Accessories that can be purchased additionally		S-VIDEO Cable	-	Internal shopping mall
		HDMI Cable	-	
		HDMI/DVI cable	-	
		Component Cables (RCA)	-	
		PC Cable	-	
		PC Audio Cable	-	
		Antenna Cable	-	
		Scart Cable	-	

MEMO

14. Reference Information

14-1 Other issues related to other products

Problem	Descriptions
A fixed screen can cause permanent damage to the TV Braun tube.	Braun, PDP and LCD TVs can all be damaged. When a still image is displayed in a sequence, this can leave stains or after-images due to the characteristics of the panel. However, the DLP TV has the advantage that no stains or after-images are left on the screen. The DLP TV has mirror pixels on the DMD panel that project the beam onto the screen, in which the mirror is a digital representation of 0s and 1s, leaving no trace of light. The mirror returns to a blank state so that no stains or after-images are left.
Length of DVI Cable / PC RGB Cable	<ul style="list-style-type: none"> - A too long DVI cable may cause a malfunction or degradation of the visual quality due to an attenuation of the signal. There is no recommendation for the cable length at present. In general, although a cable length of up to 5 meters should work, please check if video is properly displayed on the screen after connecting. If you think the length of the cable is longer than for normal use, check the visual quality of the video on the screen and shorten the length, if necessary. - This also applies to the PC RGB (D-Sub) cable. When the length of the cable is longer than for normal use, video may not be displayed on the screen. In this case, shorten the cable length.
When a digitally distributed TV user receives HD-rated broadcasts:	The digital distributed TV (Ready Technique) can render HD sources as HD-rated. However, you need to install a set-top box for this purpose. The digital TV alone cannot render HD broadcasting as HD-rated. Install the formal set-top box for HD broadcasts.
When a digital distributed TV user selects normal size (4:3) to receive SD-rated digital broadcasts:	The digitally distributed TV (Ready Technique) renders any broadcasting service as SD-rated. However, when connected to a set-top box, the digital TV renders HD broadcasts as HD-rated and renders SD as SD-rated. The screen size is scaled to 4:3.
When a digitally built-in TV user receives SD (air) broadcasting:	The digitally integrated TV ("built-in" type) renders SD broadcasting as SD-rated. This can be understood easily. Even a high-resolution TV cannot improve a low resolution picture into high quality. In contrast, an SD-rated TV cannot represent HD broadcasting as HD because the resolution of the TV is lower than the original.
When selecting a picture size of 4:3 in connection with a computer or a multimedia device:	The representation capability of SD or HD-rated depend entirely on the TV set. The HD TV can render HD broadcasting as HD-rated only when it receives HD sources. In the meantime, the HD TV renders SD as SD-rated when it receives SD sources. The picture size has nothing to do with the resolution; TV models like SVP-XXL3HD or SVP-XXL6HD have a size adjustment feature to 16:9, 4:3, Panorama, Zoom1, Zoom2 and Auto Wide. This is about the aspect ratio of the top and bottom boundaries to the overall screen and users can select their preference.

■ SD/HD broadcasts and the TV's display capability are related

1. A digital broadcast should be transmitted in wide screen (an aspect ratio of 16:9) HD. If the broadcasting station converts a conventional program created in normal screen (aspect ratio of 4:3) into a digital signal and broadcasts the signal, the left and right of the picture will not be displayed.

This symptom also appears in other manufacturer's TV's. The three appliance companies are trying to resolve the problem through the Ministry of Information and Communication.

- * When watching an SD (normal) broadcast through a Digital (Wide) TV (480P normal broadcast)
- * When watching an SD (normal) broadcast through a Digital Ready (Wide) TV (Using a set-top-box)
- * When watching an analog (normal) broadcast through a wide TV
(When watching a broadcast after changing the aspect ratio of the TV from 16:9 (wide screen) to 4:3)

2. When watching a DVD title or video tape in wide screen (21:9) through a wide (16:9) TV, watching video from a computer or game console by selecting the aspect ratio to 4:3, or watching video from a DVD, VCR, computer or game console through a wide TV by selecting the aspect ratio to normal (4:3) or wide (21:9), the left and right, or top and bottom of the picture will not be displayed.

This symptom appears in other manufacturer's TV's. The three appliance companies are trying to resolve the problem through the Ministry of Information and Communication.

■ Changing the Order of the Picture Size for 16:9 Display Devices

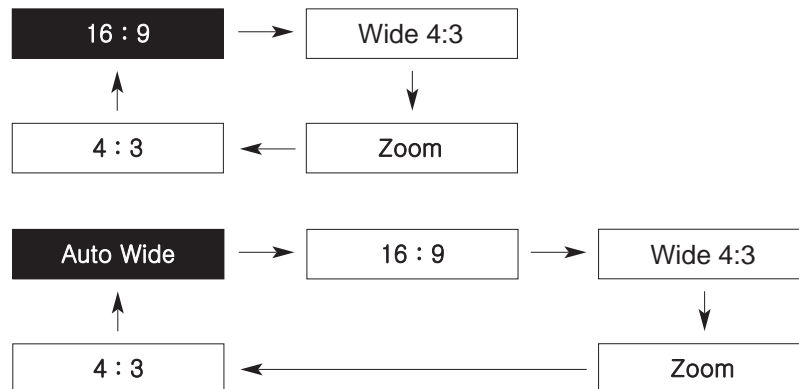

■ Changing the Order of the Picture Size for DTV 1080i/720p Sources



■ Restrictions

1. When you want to change the picture size in PIP 'ON', you must turn the PIP off before changing the size. However, you can change the main picture size even in PIP ON for products with no restrictions.
2. When the picture size is not Normal (4:3 for 4:3 display devices, 16:9 for 16:9 display devices) and you turn PIP on, the picture size is changed to Normal. However, you can turn PIP on without changing the picture size for products with no restrictions.
3. In the OSD notation for the picture size, 16:9 is represented as "Wide" instead of "16:9" for devices other than with 16:9 displays.
Ex: For LCD 15:9 devices, "Wide" is displayed on the OSD instead of "16:9".
4. The picture size can be changed even in the blue screen. However, the picture size should be controlled by the product specifications if the change is impossible due to hardware restrictions.

14-2 Technical Terms

Virtual Channel

In digital channels, a virtual channel is used. A virtual channel is a function that enables users to watch a channel by selecting a virtual channel number regardless of the region of the user. Run Auto Channel Scan for digital broadcasts, tune in to a UHF channel number according to the region for terrestrial broadcasts, or tune into a channel number allocated by the cable broadcasting station for a cable TV network, and then select a displayed virtual channel.

For example, even if you tune into channels UHF 14(MBC), 15(KBS1), 16(SBS), 17(KBS2) and 18(EBS) broadcast from Kwanak mountain in Seoul, you can watch the channels using virtual channels such as 11-1(MBC), 9-1(KBS1), 6-1(SBS), 7-1(KBS2) and 10-1(EBS) regardless of your region and the actual local channel number. The virtual channel numbers may be used nationwide, but the virtual channel numbers may vary depending on the local broadcasting stations.

(Since the digital channel numbers may vary depending on your region and can be changed by the broadcasting policy, ask your local broadcasting station or regional cable TV network company about the channel numbers.) If the virtual channel numbers are saved and the TV set can receive digital broadcasting, you can watch a digital channel by pressing the DTV+ button and pressing the first two digits of the corresponding virtual channel number.

Custom Color Adjustment

Using this function, a user can adjust the color according to personal preferences (Red, Grass-Color, Sky-Color, Gold-Color, Skin-Color, White, Standard, Custom) without affecting other colors using automatic selection mode or fine adjustment mode.

Simultaneous Screen

Using this function, a user can view two video signals from separate video sources on a single screen at the same time. For example, you can watch TV and video simultaneously.

Dolby Digital

This is the digital sound standard developed by the Dolby Laboratory. You can select your preferred digital surround mode after connecting external speakers.

Digital Broadcasting

Digital Broadcasting is a television broadcasting signal digitized and transmitted according to the United States' terrestrial digital broadcast standard, or ATSC.

Mono

A type of audio interface that transmits the audio signal through a single channel only.

Through a mono interface, it is hard to experience stereophonic sound and the sound is played using only one speaker.

Reception Sensitivity Amplification (LNA)

A signal amplification technique that amplifies a weak broadcasting signal by applying satellite technology to provide better visual quality even for users in regions where only a weak broadcasting signal is available. (LNA: Low Noise Amplifier)

Sub Woofer

A Sub Woofer is a speaker for ultra bass sound output only whose frequency is as low as 150Hz. There are two types: an active type which includes an amplifier, and a passive type, which requires an additional amplifier.

Stereo

A type of audio interface that transmits audio signal through 2 channels.

Stereo transmits audio signals for right and left sound so that you can experience stereophonic sound, and the sound is played through 2 speakers.

Partial Color Blind Person Mode

Using this function, a user can adjust the red, green or blue colors according to the preferences of the partially color-blind person so that he or she can view the clearest possible picture on the screen.

Analog Broadcasting

Analog Broadcasting is a television broadcasting signal transmitted according to the NTSC standard.

ANTENNA IN Port

The port connecting the TV aerial via a coaxial cable. It is generally used for watching public broadcast programs.

English Caption

A function that displays English captions or text information included in the broadcast signal or video tape. You can use this function for your English studies by watching AFKN or CC marked video tapes.

Video/Audio Ports

You may experience poor visual and audio quality when watching a video tape on channel 3 or 4 through the antenna cable. You can experience better visual and audio quality by connecting the TV and VCR through the Video/Audio ports. The video port is in yellow, and the audio ports are in white and red.

Wide Screen

Wide Screen refers to a screen that is horizontally longer than a conventional TV screen.

While the aspect ratio of a normal TV is 4 : 3, that of a wide screen is 16 : 9.

External Input

External Input is a connected video device such as a VCR, camcorder, DTV receiver, DVD, etc. as a video source.

Satellite Broadcasting

Satellite Broadcasting transmits programs via satellite so that a program can be viable in all areas at a high visual and sound quality. Approximately 100 channels including public broadcast channels are provided. To view a satellite broadcast, you have to install an additional receiver.

Wire Broadcasting

Wire Broadcasting refers to movie, entertainment and educational programs transmitted by a broadcasting station within a hotel or school.

Audio Multimix

Audio Multimix provides 2 audio languages when foreign movie, drama, news, etc. are broadcast. You can select and listen to one of the supported languages or you can select and listen to both languages simultaneously.

After-Image Protection

Using this function, a user can configure the options necessary for protecting the PDP TV screen.

Power Saving Mode

This function adjusts the screen brightness according to the ambient brightness so as to conserve power.

Component Port

The Component Port transmits a separate luminance signal as well as the green, blue, and red color signal and provides the best quality of all video connection types.

Cable Broadcasting

Cable Broadcasting transmits programs via cable instead of via the air. To view cable broadcasting, you have to subscribe to your local cable broadcast service provider and install an additional receiver.

Tuner

A device that enables the selecting of specific channel frequencies for TV or radio.

Panorama Screen

This refers to a screen that corrects the picture distortion due to a screen size mismatch on the TV.

Progressive Scan

Progressive scan displays the entire frame in a single sweep so as to provide clearer and sharper visual quality.

DVD (Digital Versatile Disc)

DVD is a large capacity storage media that can store multimedia content such as video, games, audio applications, etc. using MPEG-2 video compression technology on a CD sized disc

DRC

This is a sound quality enhancement function that automatically controls audio output so as to prevent sound quality distortion even at loud volumes and correct the sound to the speakers so that you can listen to the sound at the original sound quality.

DVI (Digital Visual Interface) Port

A DVI interface is a standard for high definition television connectivity. It provides a clear picture on the screen using TMDS which minimizes video signal loss.

DVI-D Cable

A type of DVI connector. Using this cable you can only transmit digital signals.

DVI-I Cable

A type of DVI connector. Using this cable you can transmit either digital or analog signals.

HDMI

HDMI (High-Definition Multimedia Interface) is the first industry-supported, uncompressed, all-digital audio/video interface. HDMI provides an interface between any audio/video source, such as a set-top box, DVD player, and A/V receiver and an audio and/or video monitor, such as a digital television (DTV). HDMI supports standard, enhanced, or high-definition video, plus multi-channel digital audio on a single cable. It transmits all ATSC HDTV standards and supports 8-channel digital audio, with bandwidth to spare to accommodate future enhancements and requirements.

PCM

PCM (Pulse Coded Modulation): This refers to an uncompressed digital signal. Use this for an AV amplifier that does not support 5.1 channels when connecting the audio output via optical or coaxial cable.

SRS TruSurround XT

This function provides 5.1 channel surround sound using 2 channel speakers when inputting a stereo audio signal.

VESA Plug & Play

This function enables the automatic recognition of devices when connecting the TV to the computer without additional settings.

S-VIDEO IN Port

This is called super video. S-Video is a type of video signal which has the video luminance and the color signal separated in order to provide better visual quality.

Pixels, Resolution

The pixels are the number of small dots that make up the TV screen. The resolution represents the number of pixels on a screen. For example, if the resolution of a TV is 852x480, it means the width of the screen consists of 852 pixel columns and the height of the screen consists of 480 pixel rows. In this case, the total number of pixels on the screen is 408,960. The more pixels there are, the higher the visual quality that can be achieved because the picture on the screen is displayed with more pixels and therefore with more detail.

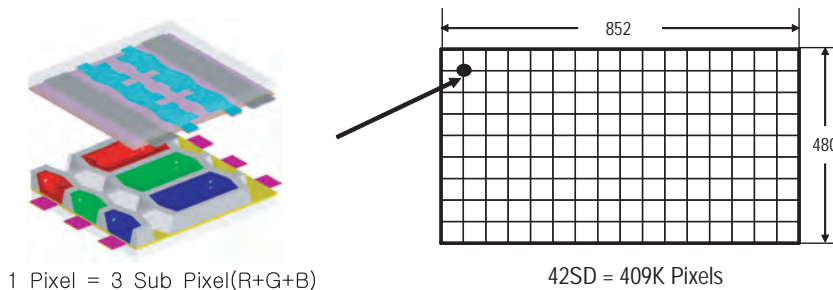

Gradation, Color Depth

Gradation describes the number of gradual brightness levels. Since all information is represented by binary numbers in a digital system, the Gradation is determined by the number of bits used to represent the brightness levels of a pixel on the TV screen. For example, if a pixel is represented by 8 bits, the Gradation is 28 or 256. Since a TV uses the three primary colors of light, R, G and B, the number of possible colors for a pixel is $256 \times 256 \times 256$, 16,777,216, or 16.7 million colors. If 12 bits are used for a pixel, the gradation is 212 or 4096 for a color. Since three colors R, G and B are used, $4096 \times 4096 \times 4096$ or 68.7 billion colors are supported per pixel. Since 68.7 billion colors are far more than 16.7 million colors, the picture will be displayed by far more abundant and natural colors using a 12 bit pixel. That is, since Gradation means the number of brightness levels, color represented by 4096 levels appears more natural than color represented by 256 levels.

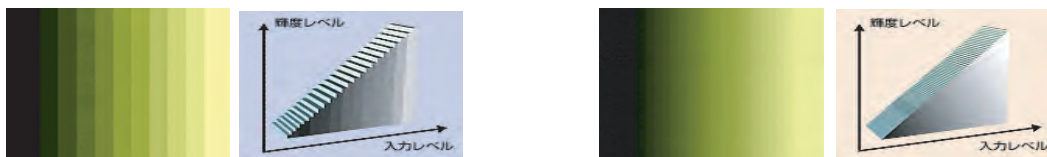

Contrast

The contrast is the ratio of brightness of the brightest color to the darkest color. The contrast is calculated by dividing the brightness of the brightest color by the brightness of the darkest color. For example, if the brightness of the darkest color is 1 and the brightness of the brightest color is 3000, then the Contrast is $3000/1$ or 3000. A higher contrast means that a dark color is displayed darker and bright color is displayed brighter so that the screen contrast can be easily distinguished. The contrast differs from the Gradient which means the number of brightness levels.

Therefore, if someone says that a 5000:1 contrast displays a color by 5000 levels, he is confusing Contrast with Gradation.

Brightness

Brightness is the brightness per unit screen area, the unit for brightness is candela (cd). For example, 1000cd/m² means the brightness that is measured when 1000 candles are lit within 1 square meters area.

Color Reproductivity

Each color displayed on the TV screen is implemented by a pixel on color coordinates which have an X and Y axis.

For example, when a pixel on the X coordinate 0.65 and the Y coordinate 0.74 is displayed as a color and it becomes visible on the TV screen. While the possible color coordinate area is very wide, the color coordinate area of the signal broadcast from a broadcast station is smaller than that of possible color coordinates. Moreover, a TV provides a smaller color coordinate area than that of the signal from the broadcasting station even though the size of the color coordinate area varies depending on the TV model. In general, Color Reproductivity is used as follows:

The Color reproductivity of a TV is a certain % of NTSC. This means the TV displays that particular % of the color coordinate area of the NTSC signal broadcast by the broadcasting station. In general, a CRT TV provides the highest functional color reproductivity.

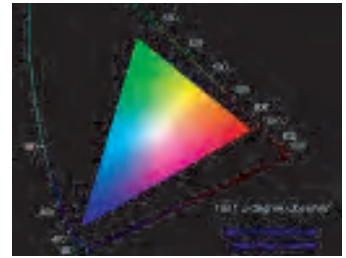

5. Electrical Part List

5-1 PS42E7SX/XEC Service Item

You can search for the updated part code through ITSELF web site.

URL:<http://itself.sec.samsung.co.kr>

Loc. No.	Code No.	Description	Specification	Q'ty	SA/SNA	Remark
M0003	BN96-02746B	ASSY STAND P-SET RIGHT	42E7,HIPS HB,GRAY	1	S.A	
M0013	BN96-03069A	ASSY COVER P-REAR	42E7,PCM T0.5	1	S.A	
M0013	BN96-03070B	ASSY COVER P-REAR BOTTOM	42E7,HIPS HB,BK	1	S.A	
M0018	BN97-00857A	ASSY MICOM	T-AUDMPEU-S-1001,PS42E7,D74A,	1	S.A	
M0216	BN96-02747B	ASSY STAND P-SET LEFT	42E7,HIPS HB,GRAY,	1	S.A	
M2893	BN39-00164E	LEAD CONNECTOR	Twister,UL1015#18,1P,300m	1	S.A	
M2893	BN39-00632B	LEAD CONNECTOR	PS-42E7HX/XEC,UL1617#22,U	1	S.A	
M2893	BN39-00667D	LEAD CONNECTOR-LVDS	AUDI,UL20276#30,31PI	1	S.A	
M2893	BN39-00675A	LEAD CONNECTOR	PUCCINI,UL1007#26,10PIN,1	1	S.A	
M2893	BN39-00676A	LEAD CONNECTOR	PUCCINI,UL1007#26,12PIN,1	1	S.A	
T0003	BN96-03625D	ASSY COVER P-FRONT	42E7S(HQ),XEC,HIPS HB	1	S.A	
T0044	BN96-03073A	ASSY PDP MODULE P	M1,SPD-42D5SD,D71C,V5.	1	S.A	
T0074	BN59-00531A	REMOCON	AUDI,TM86,SAMSUNG,45Key,31mArms,	1	S.A	
T0079	BN94-00933B	ASSY PCB MISC-MAIN	PS-42E7S,EU,D74A,AUDI	1	S.A	
T0159	BN96-01856A	ASSY PCB P-SMPS	SPD-50P5HD(DC_DC),200Vin	1	S.A	
T0159	BN96-03052A	ASSY PCB P-SMPS	PS42E7H,100-240V,245*370	1	S.A	
T0175	BN96-02785A	ASSY SPEAKER P	8ohm,Twister,42inch,10W	1	S.A	
T1910	BN96-03101A	ASSY PDP MODULE P-X-MAIN BOARD	M1,PL42SD	1	S.A	
T1911	BN96-03102A	ASSY PDP MODULE P-Y-MAIN BOARD	M1,PL42SD	1	S.A	
T1912	BN96-03103A	ASSY PDP MODULE P-Y-SCAN BUFFE	M1,PL42SD	1	S.A	
T1914	BN96-03104A	ASSY PDP MODULE P-ADDRESS E-BU	M1,PL42SD	1	S.A	
T1915	BN96-03105A	ASSY PDP MODULE P-ADDRESS F-BU	M1,PL42SD	1	S.A	
T1917	BN96-03106A	ASSY PDP MODULE P-LOGIC MAIN B	M1,PL42SD	1	S.A	

MEMO

6. Troubleshooting

6-1 First Checklist for Troubleshooting

1. Check the various cable connections first.
 - Check to see if there is a burnt or damaged cable.
 - Check to see if there is a disconnected cable connection or a connection is too loose.
 - Check to see if the cables are connected according to the connection diagram.
2. Check the power input to the Main Board.
3. Check the voltage in and out between the SMPS ↔ Main Board, between the SMPS ↔ X, Y Main Board, and between the Logic Boards.

6-2 Checkpoints by Error Mode

6-2-1 No Power

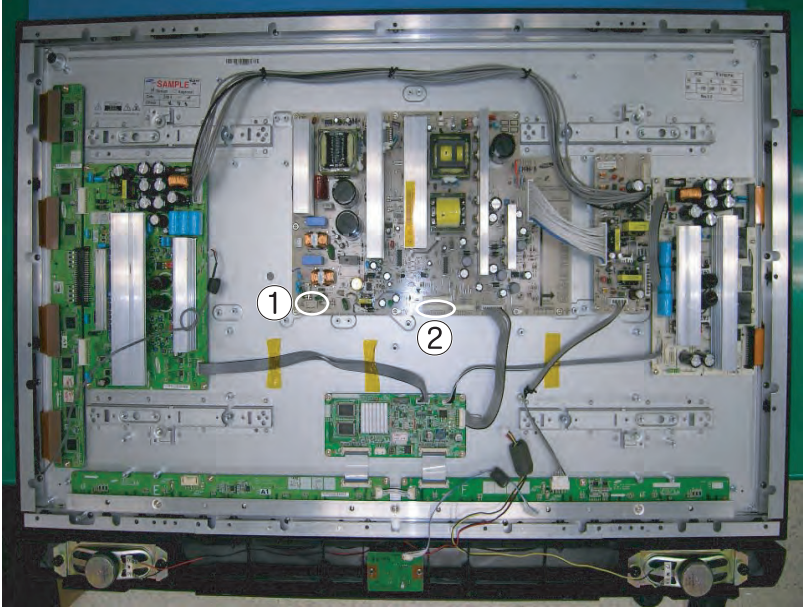
Symptom	<ul style="list-style-type: none"> - The LEDs on the front panel do not work when connecting the power cord. - The SMPS relay does not work when connecting the power cord. - The power of the unit seems to be out of order.
Major Checklist	<p>The SMPS relay or the LEDs on the front panel do not work when connecting the power cord if the cables are improperly connected or the Main Board or SMPS is out of order. In this case, check the following:</p> <ul style="list-style-type: none"> - Check the internal cable connection status inside the unit. - Check the fuses of each part. - Check the output voltage of SMPS. - Replace the Main Board.
Troubleshooting Procedures	<div style="text-align: center;">  </div> <pre> graph TD Q1["① Are the AC IN socket connector and the Main SMPS CN800 connected?"] A1["The AC IN socket connector and the Main SMPS CN800 connected"] Q2["① Is the Fuse (F801S) of the Main SMPS Power Input Part blown?"] A2["Replace Fuse (F801S)"] Q3["② Main SMPS CN804-1 Pin 3 : STB 5V Pin 8 PS-ON : Check to see if it is 0V"] A3["Replace the Main SMPS"] A4["Replace the Main Board"] Q1 -- No --> A1 Q1 -- Yes --> Q2 Q2 -- No --> A2 Q2 -- Yes --> Q3 Q3 -- No --> A3 Q3 -- Yes --> A4 </pre>

6-2-2 When the unit is repeatedly turned on and off

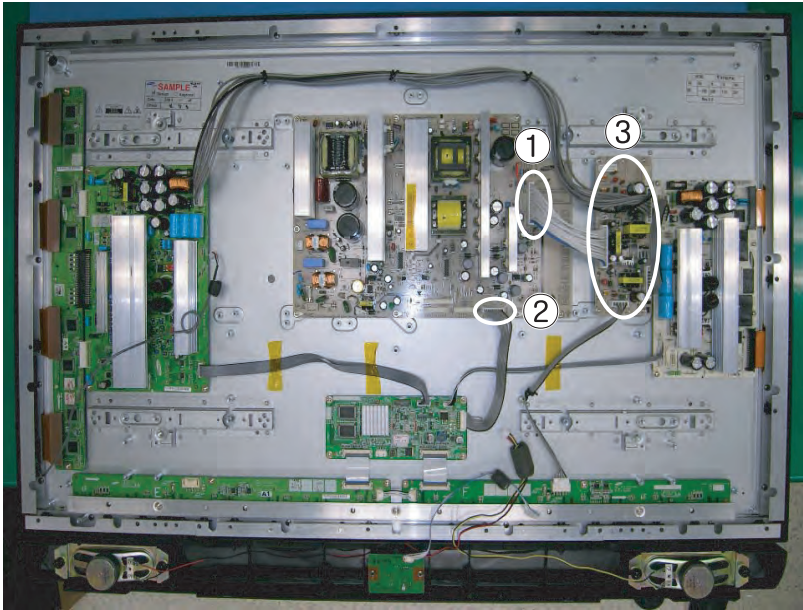
Symptom	- The SMPS relay is repeatedly turned on and off.
Major Checklist	<p>In general, the SMPS relay repeatedly turns on and off by the protection function due to a defect on a board connected to the SMPS.</p> <ul style="list-style-type: none"> - Disconnect all cables from the SMPS, operate the SMPS alone and check if the SMPS works properly and if each voltage output is correct. - If the symptom continues even when SMPS is operated alone, replace the SMPS. - If the symptom is not observed when operating the SMPS alone, find any defective ASSYs by connecting the cables one by one.
Troubleshooting Procedures	 <p>The image shows the internal components of the unit. Three areas are circled and numbered: 1 points to the DC-DC SMPS area, 2 points to the Main SMPS area, and 3 points to the X Main Board area.</p> <pre> graph TD Q1["① Does the symptom continue after connecting the power and removing the CN809 cable from the Main SMPS?"] Q2["② Does the symptom continue after connecting the power and removing the CN804-2 cable from the Main SMPS?"] Q3["③ Does the symptom continue when connecting the power after connecting the CN809 cable and removing the CN1, CN2, CN4 and CN6 cables from the DC-DC SMPS?"] Q4["③ Does the symptom continue when connecting the power after removing the CN4 cable from the DC-DC SMPS?"] Q5["③ Does the symptom continue when connecting the power after removing CN2 from the DC-DC SMPS?"] Q6["② Does the symptom continue when connecting the power after removing CN810 from the Main SMPS?"] R1["Replace the Main SMPS"] R2["Replace the DC-DC SMPS"] R3["Replace the X Main Board"] R4["Replace the Y Main Board"] R5["Replace the Logic Board"] Q1 -- Yes --> R1 Q1 -- No --> Q3 Q2 -- Yes --> R1 Q2 -- No --> Q3 Q3 --> R2 Q3 --> Q4 Q4 --> R3 Q4 --> Q5 Q5 --> R4 Q5 --> Q6 Q6 --> R5 </pre>
Caution	When separating and connecting the cables such as CN809 of the Main SMPS, CN1, CN2, CN3, CN4 and CN5 of DC-DC SMPS, CN of the X Main Board, and CN of the Y Main Board, a spark may be generated by the electric charge of the high capacity capacitor. Therefore, wait some time after separating the power cord from the unit.

6-2-3 No Picture (When audio is normal)

Symptom	- Audio is normal but no picture is displayed on the screen.
Major Checklist	- This may happen when the Main Board is normal but the X, Y Main Board, Logic Board, or Y Buffer Board is out of order. - The output voltage of the Main SMPS or the DC-DC SMPS is out of order. - This may happen when the LVDS cable connecting the Main Board and the Logic Board is disconnected.

Troubleshooting Procedures

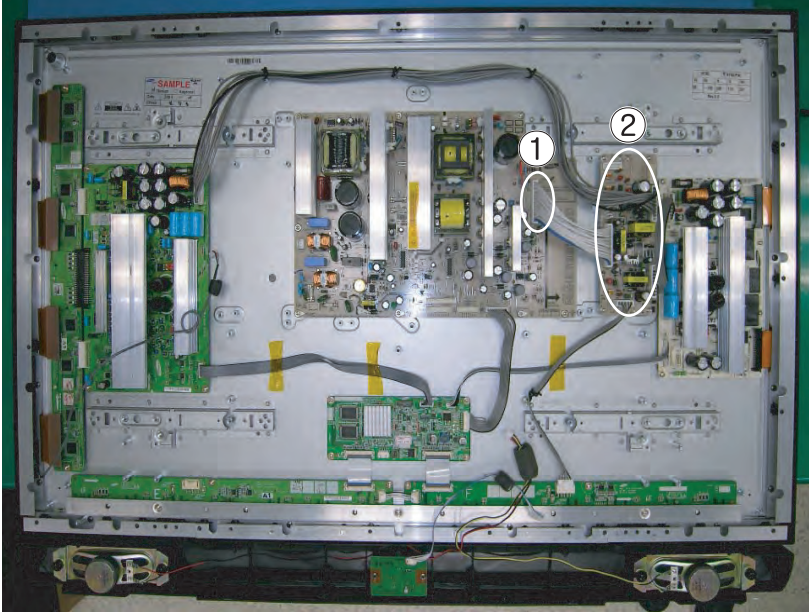

The image shows the internal components of a TV chassis. Two areas are circled and numbered: '1' points to the Main SMPS (Switching Mode Power Supply) located in the upper right quadrant, and '2' points to the DC-DC SMPS located in the upper right quadrant, below the Main SMPS.

```

graph TD
    Q1["① Are the Vs and Va voltages normal after removing the CN809 cable from the Main SMPS?"]
    A1["No"] --> R1["Replace the Main SMPS"]
    Q1 -- Yes --> Q2["② Is the output voltage of the DC-DC SMPS normal when reconnecting the CN809 cable and removing the CN1, CN2, CN4 and CN6 cables from the DC-DC SMPS?"]
    A2["No"] --> R2["Replace the DC-DC SMPS"]
    Q2 -- Yes --> R3["Replace the Y Main Board"]
    R3 --> R4["Replace the X Main Board"]
    R4 --> R5["Replace the Logic Board"]
    R5 --> R6["Replace the Y Scan Board"]
    
```

Caution	When separating and connecting the cables such as CN809 of the Main SMPS, CN1, CN2, CN3, CN4 and CN5 of the DC-DC SMPS, CN of the X Main Board, and CN of the Y Main Board, a spark may be generated by the electric charge of the high capacity capacitor. Therefore, wait some time after separating the power cord from the unit.
---------	--

6-2-4 No Sound

Symptom	- Video is normal but there is no sound.
Major Checklist	- When the speaker connectors are disconnected or damaged. - When the sound processing part of the Main Board is out of order. - Speaker defect.

Troubleshooting Procedures

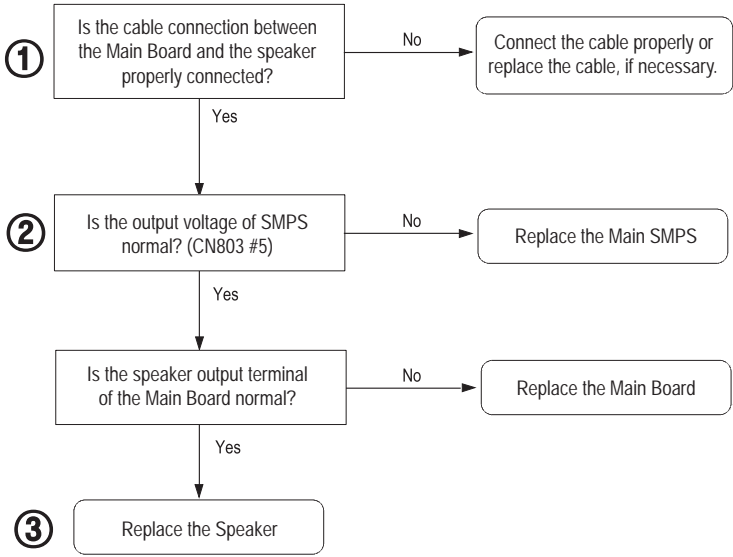
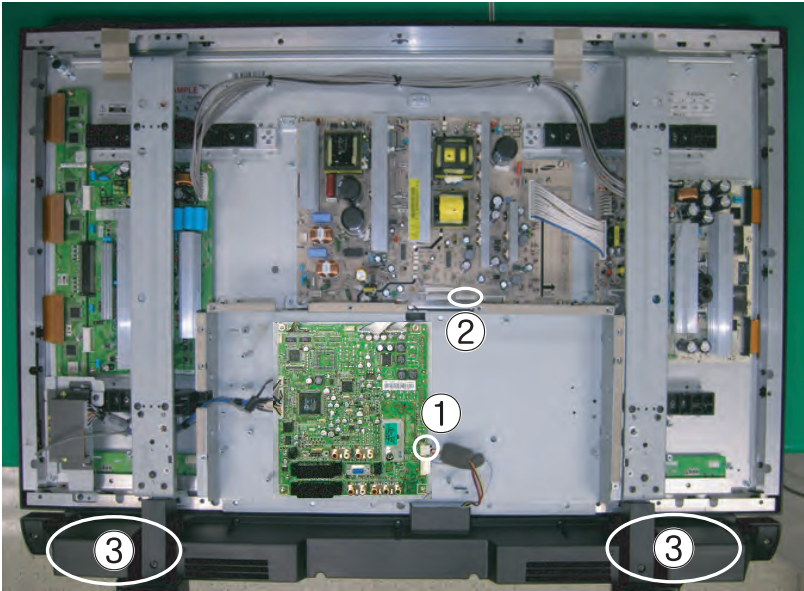

6-2-5 No Video

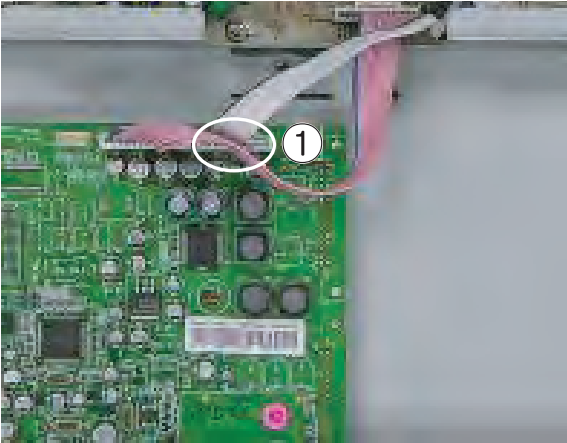
Symptom	- A normal/cable network analog broadcast screen is blank or abnormal.
Major Checklist	<ul style="list-style-type: none"> - Check the antenna connection settings (Antenna 1 - Normal/Cable/DTV, Antenna 2 - Only for DTV) - Check the tuner output signal (CVBS). - Check the power input of the Main board.
Troubleshooting Procedures	<div style="text-align: center;">  </div> <pre> graph TD Q1[Is the antenna connection setting properly configured?] -- No --> A1[Configure properly] Q1 -- Yes --> Q2[1 Check CN101 pin2 for +33V] Q2 -- No --> A2[Replace the Main SMPS] Q2 -- Yes --> A3[Replace the Main Board] </pre>

6-2-6 Main SMPS Troubleshooting

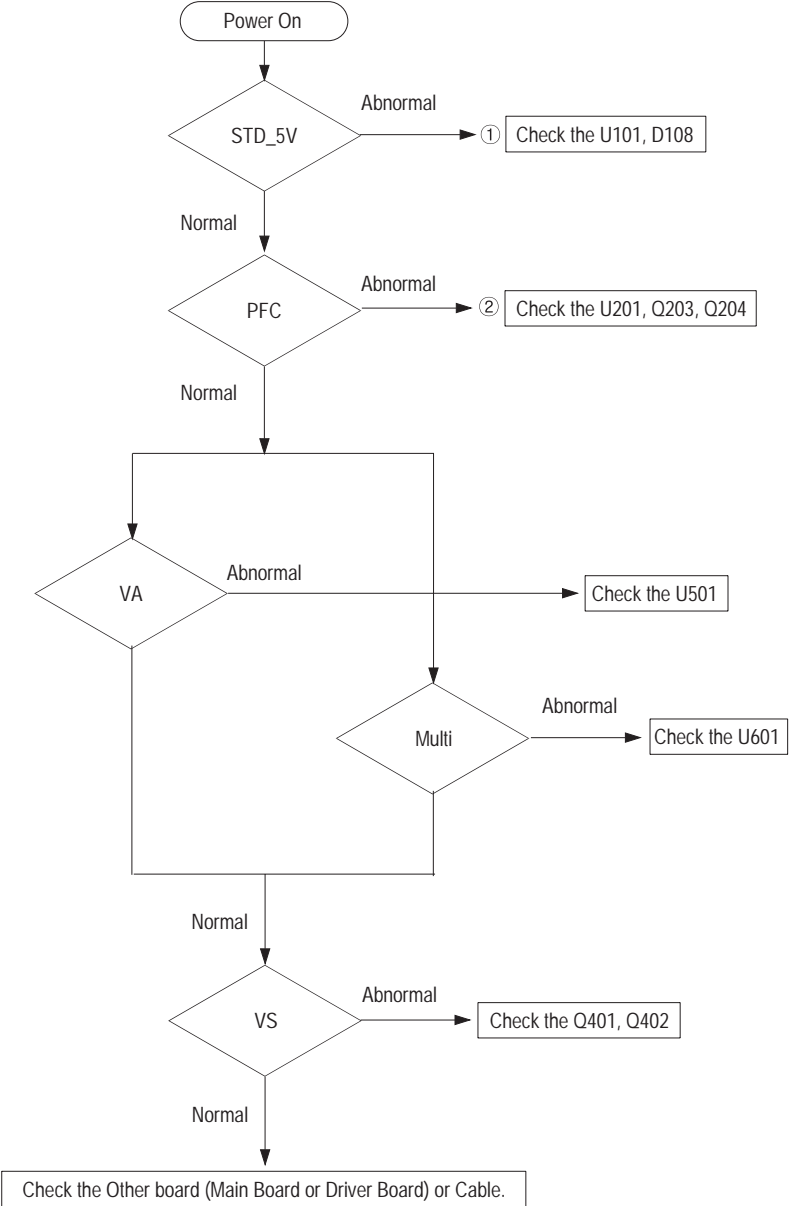

6-2-7 Drive Board Troubleshooting

1) Troubleshooting Summary

Condition Name	Description	Related Board
No Voltage Output	Operating Voltage don't exist	PSU
No Display	Operating Voltage exist, but an Image doesn't exist on screen	Y-MAIN, X-MAIN, Logic Main, Cable
Abnormal Display	Abnormal Image (not open or short) is no screen	Y-MAIN, X-MAIN, Logic Main
Sustain Open	Some horizontal lines don't exist on screen	Scan Buffer, FPC of X/Y
Sustain Short	Some horizontal lines appear to be linked on screen	Scan Buffer, FPC of X/Y
Address Open	Some vertical lines don't exist on screen	Logic Main, Logic Buffer, TCP
Address Short	Some vertical lines appear to be linked on screen	Logic Main, Logic Buffer, TCP

2) Troubleshooting Procedure in Abnormal Conditions

① No Display (Operating Voltage exist, but an doesn't exist on Screen)

► No Display is related with Y-MAIN, X-MAIN, Logic Main and so on.

This page shows you how to check the boards, and the following pages show you how to find the defective board.

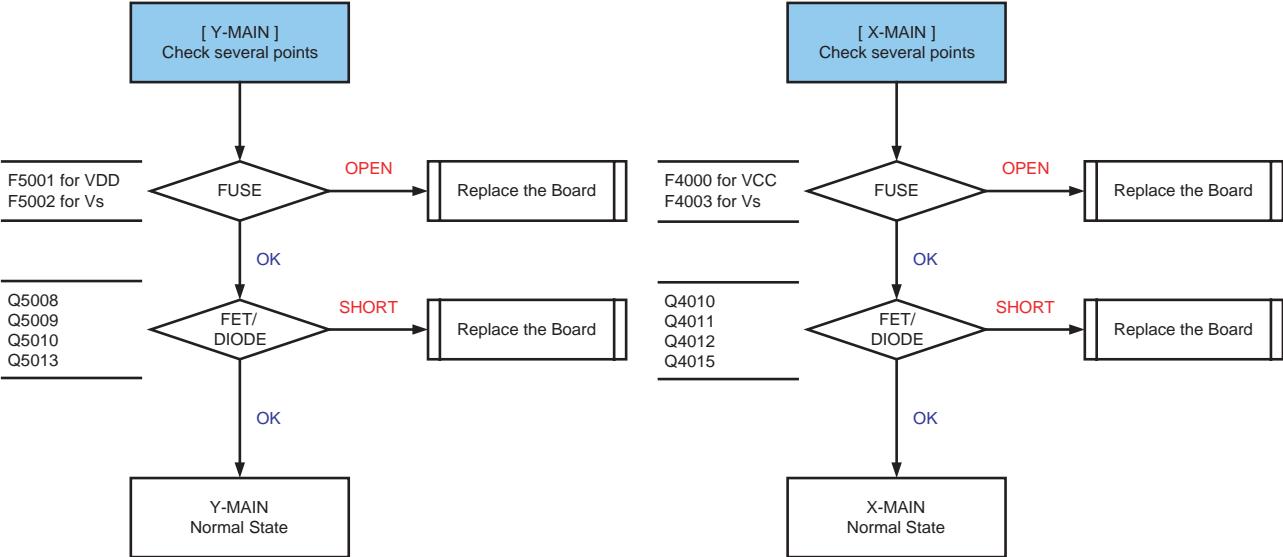
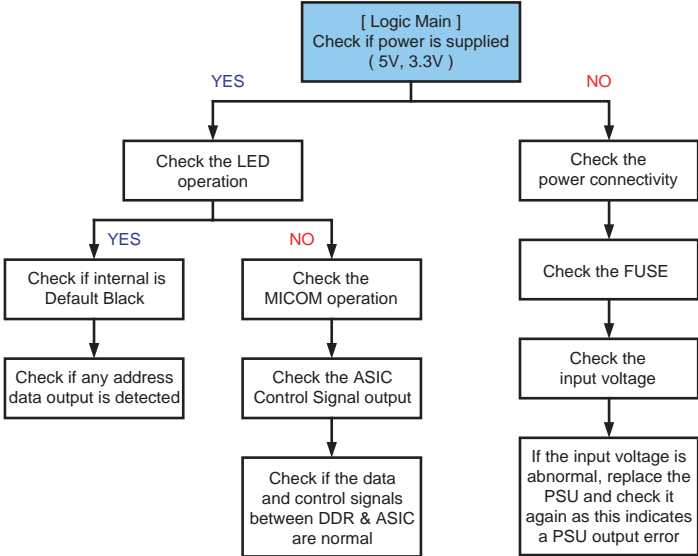
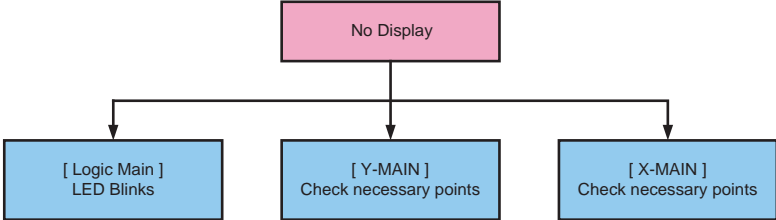

② Abnormal Display(Abnormal Image is on Screen.(except abnormality in Sustain or Address)

► Abnormal Display is related with Y-MAIN, X-MAIN, Logic Main and so on.

This page shows you how to check the boards, and the following pages show you how to find the defective board.

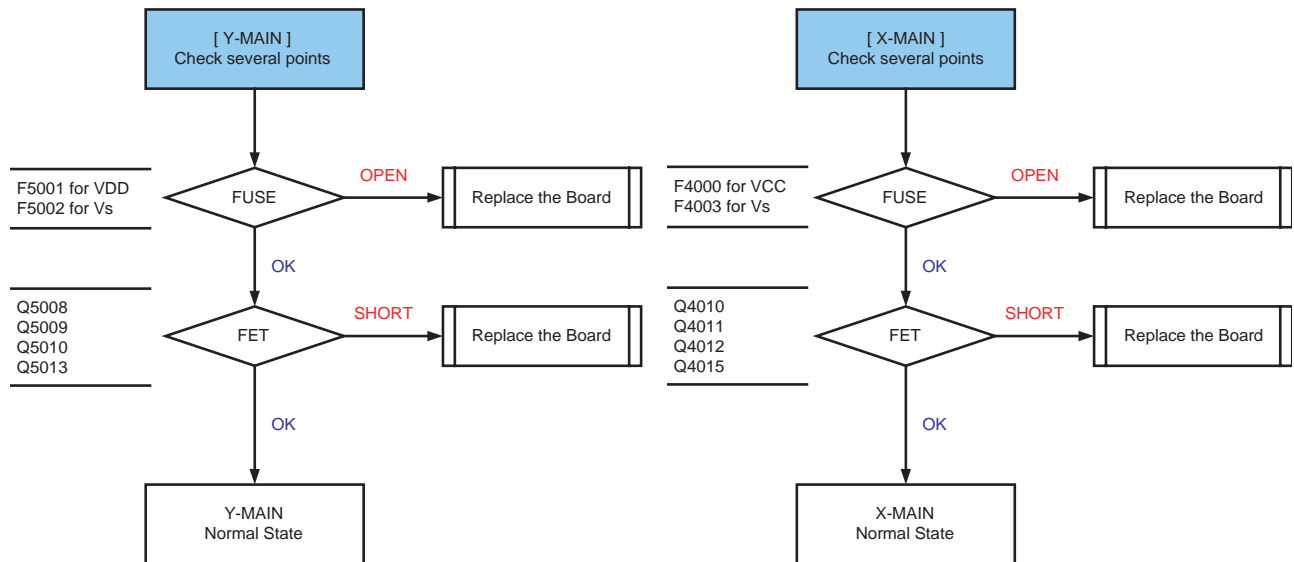
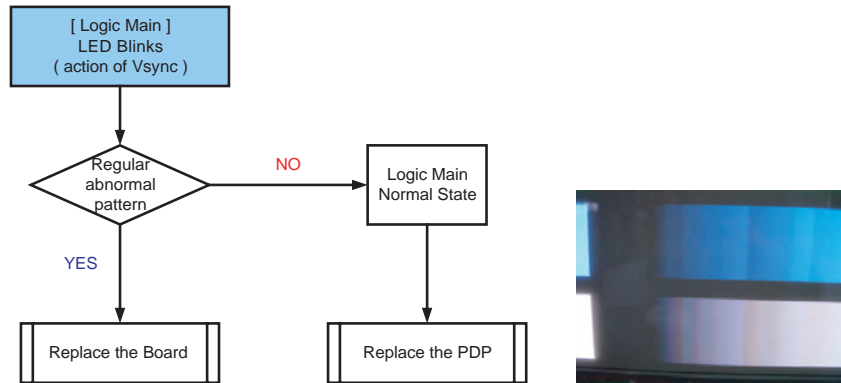
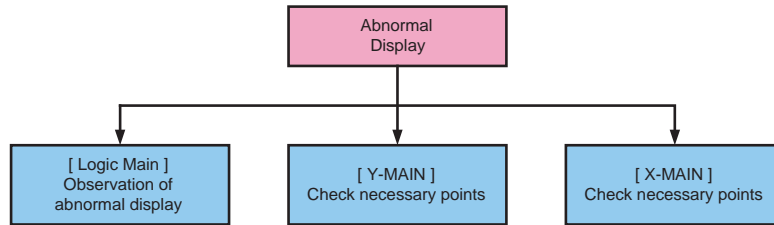

③ Sustain Open (some horizontal lines don't exist on screen)

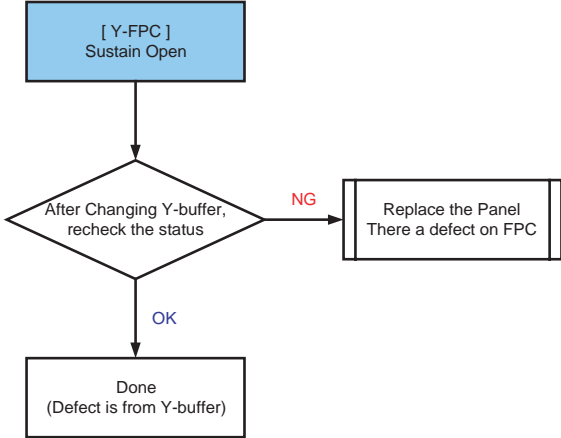

④ Sustain Short (some horizontal lines appear to be linked on Video)

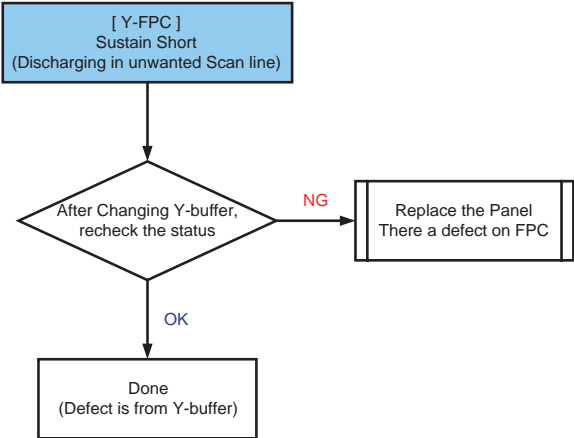

⑤ Address Open, Short (some vertical lines don't exist on screen)

▶ Address Open and Short is related with Logic Main, Logic Buffer, FFC, TCP film and so on.

This page shows you how to check the boards, and the following pages show you how to find the defective board.

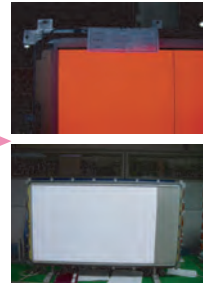
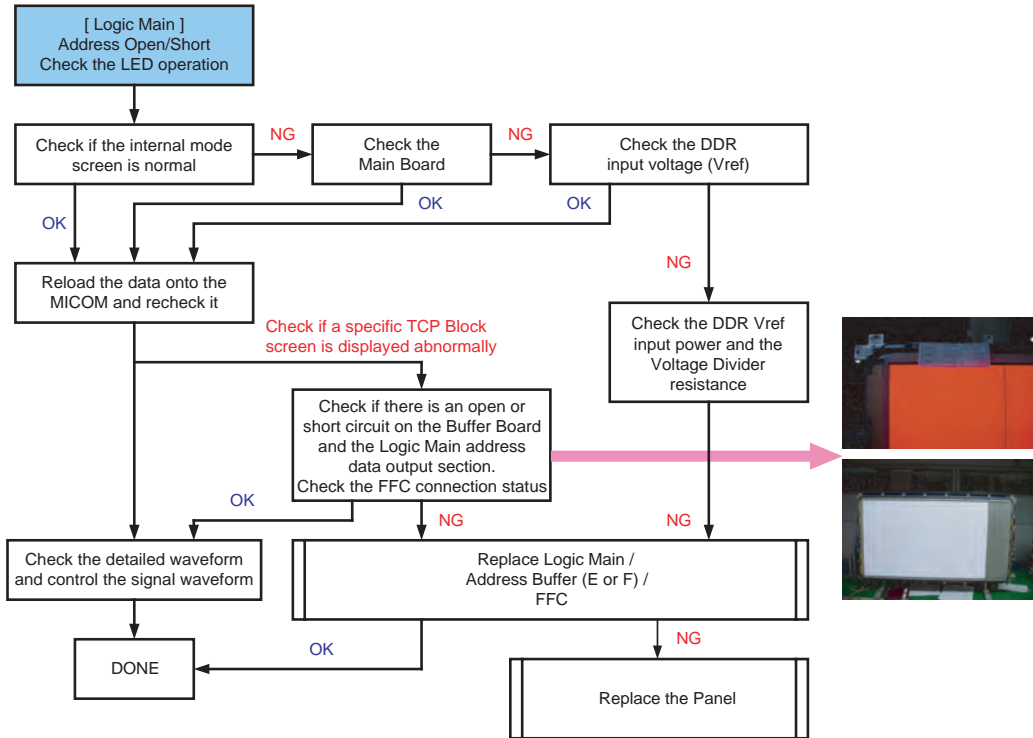

6-3 Troubleshooting Procedures by ASS'Y

※ The ASS'Y code can be changed, see "5 Chapter. Electrical Part List."

No	Assy	Code No.	Description	Major Symptoms
1	ASSY PCB P-SMPS	BN96-03052A	Main SMPS	No power, Blank screen, the Relay repeats On and Off.
2	ASSY PCB P-SMPS	BN96-01856A	DC-DC SMPS	Blank screen, the Relay repeats On and Off.
3	ASSY PDP P-X MAIN BOARD	BN96-03101A	X Main Board	Blank screen
4	ASSY PDP P-Y MAIN BOARD	BN96-03102A	Y Main Board	Blank screen
5	ASSY PDP MODULE P-LOGIC MAIN BOARD	BN96-03106A	Logic Board	Blank screen, Screen noise
6	ASSY PDP P-Y SCAN BOARD	BN96-03103A	Y Scan Board	Row Bar screen is blank
7	ASSY PDP P-ADDRESS E-BUFF BOARD	BN96-03104A	Address E Buffer Board	Corresponding Buffer Board block screen is blank.
8	ASSY PDP P-ADDRESS F-BUFF BOARD	BN96-03105A	Address F Buffer Board	Corresponding Buffer Board block screen is blank.
9	ASSY PCB MISC-MAIN	BN94-00933B	Main Board	No Power, Abnormal screen for each input source, PIP screen trouble, Sound trouble
10	ASSY BOARD P-FUNCTION	BN96-02784A	Function Key Board	The side function key does not work properly
11	ASSY BOARD P-POWER&IR	BN96-02050D	Power Button Board	The remote control does not work properly, the LED does not work properly.
12	ASSY BOARD P-SIDE AV	BN96-03075A	Side AV Board	The AV2 and S-VIDEO2 modes do not work properly

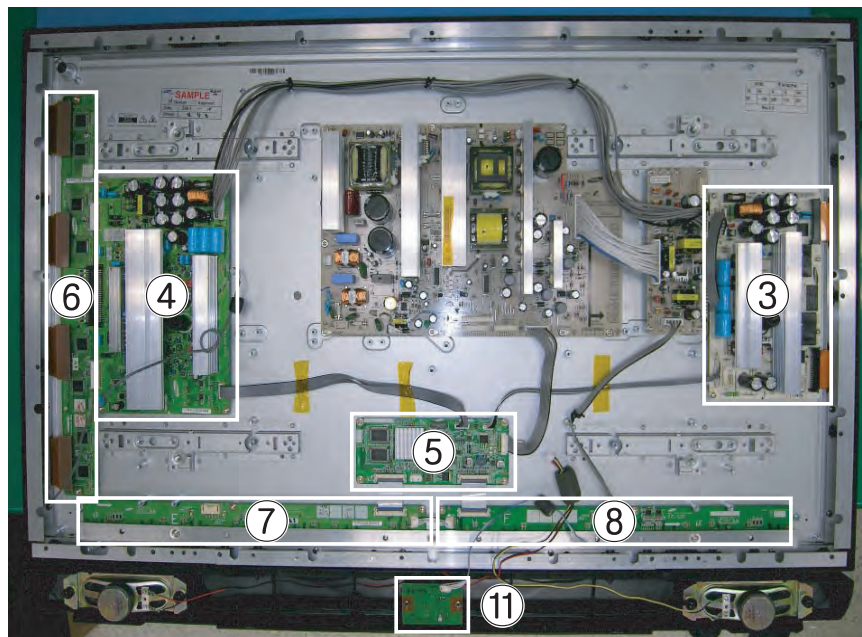
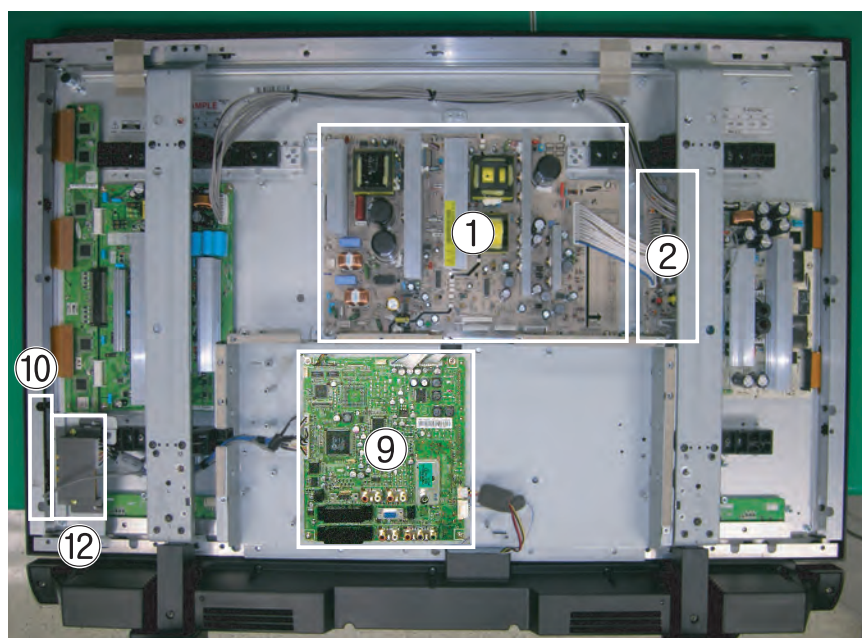

MEMO

4. Exploded View & Part List

4-1 PS42E7SX/XEC

You can search for the updated part code through ITSELF web site.
 URL:<http://itself.sec.samsung.co.kr>

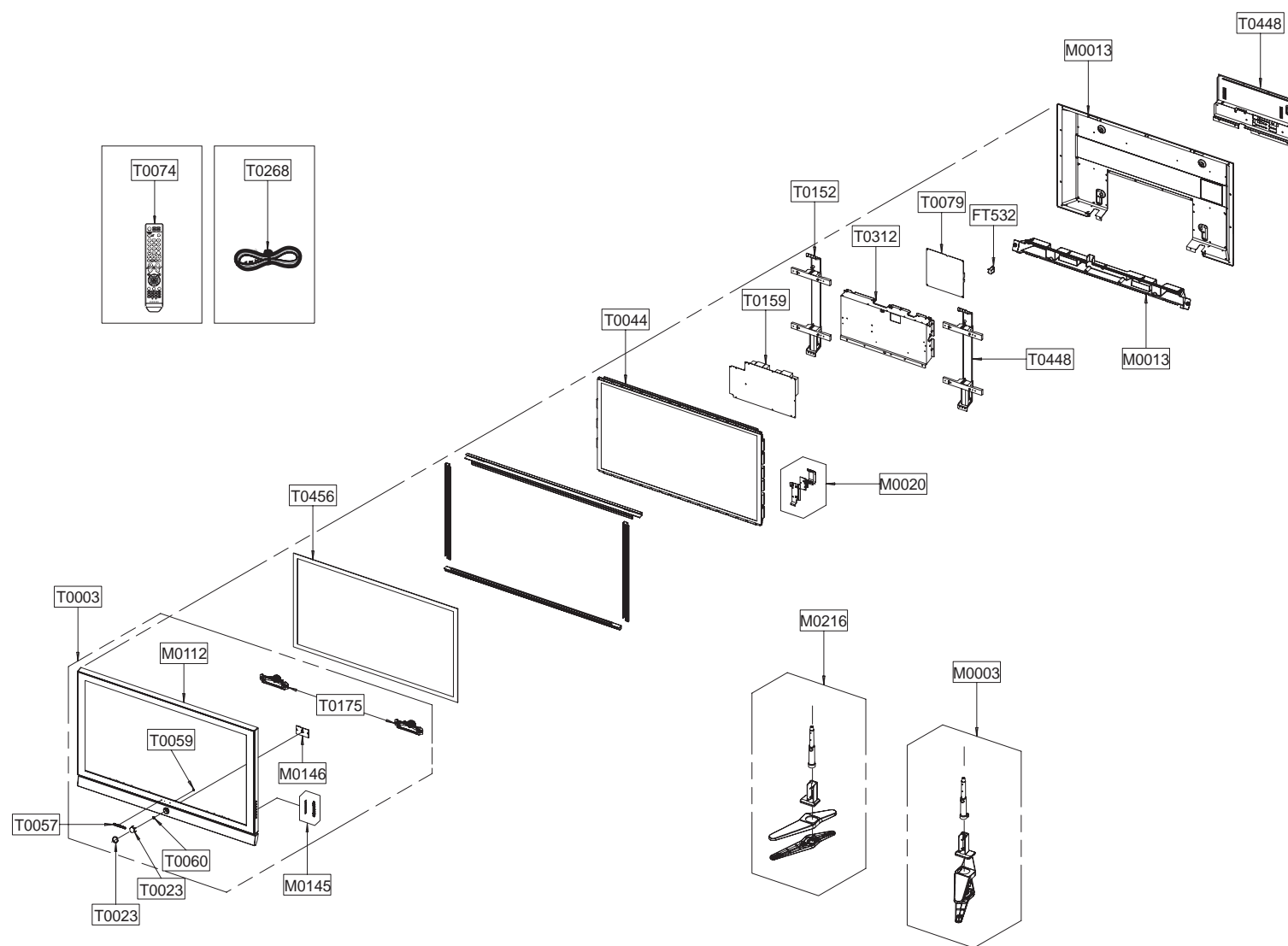

Loc. No.	Code No.	Description	Specification	Q'ty	SA/SNA	Remark
FT532	2901-001374	FILTER-EMI AC LINE	250V,6A,U/SA/VDE,0.1	1	S.A	
M0003	BN96-02746B	ASSY STAND P-SET RIGHT	42E7,HIPS HB,GRAY	1	S.A	
M0013	BN96-03069A	ASSY COVER P-REAR	42E7,PCM T0.5	1	S.A	
M0013	BN96-03070B	ASSY COVER P-REAR BOTTOM	42E7,HIPS HB,BK	1	S.A	
M0020	BN96-03075A	ASSY BOARD P-SIDE A/V	AUDI,SJ05-01-430,S	1	S.A	
M0112	BN63-02367D	COVER-FRONT	42E7S,HIPS,HB,GRAY,BKP-1526+	1	S.N.A	
M0145	BN96-02784A	ASSY BOARD P-FUNCTION	TWISTER,CT5000-385	1	S.A	
M0146	BN96-02050D	ASSY BOARD P-POWER & IR	Twister,CT5000-3	1	S.A	
M0216	BN96-02747B	ASSY STAND P-SET LEFT	42E7,HIPS HB,GRAY,	1	S.A	
T0003	BN96-03625D	ASSY COVER P-FRONT	42E7S(HQ),XEC,HIPS HB	1	S.A	
T0023	BN64-00419A	KNOB-POWER	42V6,PC,VIOLET	1	S.N.A	
T0023	BN64-00421A	KNOB POWER	42V6,DECO,ABS,HB,BLK(BK500),C	1	S.N.A	
T0044	BN96-03073A	ASSY PDP MODULE P	M1,SPD-42D5SD,D71C,V5.	1	S.A	
T0057	BP64-00177A	BADGE-BRAND	ALL,AL,T1.5,70,11.3,BLK,SILI	1	S.N.A	
T0059	BN64-00366A	INDICATOR LED	ROME-I,PC,CLEAR,ALL MODEL	1	S.N.A	
T0060	BN61-02184A	SPRING ETC	SUS304,OD11.2,L30,N7	1	S.N.A	
T0074	BN59-00531A	REMOCON	AUDI,TM86,SAMSUNG,45Key,31mArms,	1	S.A	
T0079	BN94-00933B	ASSY PCB MISC-MAIN	PS-42E7S,EU,D74A,AUDI	1	S.A	
T0152	BN96-01774A	ASSY BRACKET P-WALL RIGHT	SPD-42P5HD,SEC	1	S.N.A	
T0159	BN96-03052A	ASSY PCB P-SMPS	PS42E7H,100-240V,245*370	1	S.A	
T0175	BN96-02785A	ASSY SPEAKER P	8ohm,Twister,42inch,10W	1	S.A	
T0268	3903-000145	CBF-POWER CORD	DT,EU,FP3/YES,U(IIEC C13-R	1	S.A	
T0312	BN96-03067A	ASSY COVER P-REAR SUB	42E7,SECC,T1.0,AUD	1	S.N.A	
T0448	BN96-01775A	ASSY BRACKET P-WALL LEFT	SPD-42P5HD,SECC	1	S.N.A	
T0448	BN96-03068A	ASSY BRACKET P-TERMINAL	42E7,XEC,PCM T0.	1	S.N.A	
T0456	BN67-00160A	GLASS-FILTER EMI	42V4,Sputter,NTR,T=49%,	1	S.N.A	